

23 SUSPENDED ACCESS EQUIPMENT



TABLE OF CONTENTS

1. Introduction
2. Responsibilities and Planning
3. Fall Protection
4. Suspended Access Equipment

1. Introduction

Suspended access equipment (SAE) refers to equipment, machinery, platforms, or other devices (including all rigging and components) that are suspended by support lines and are used by workers to gain access to the sides or high-angle surfaces of buildings or structures.

With the increase in high-rise construction there has been a corresponding increase in the number and variety of applications for this type of equipment. Used correctly, these devices provide an excellent means of doing work. Used incorrectly, there can be a high risk of injury or fatality.

This chapter will cover the following:

- The main types of SAE used in construction, restoration, and maintenance work, which are suspended work platform systems (SWPS) and boatswain's (or bosun's) chairs
- The legal requirements for set-up, rigging, and use of these types of SAE
- The necessary provisions for fall protection
- The need to assess each job carefully in order to select the equipment most suitable for safe, efficient operation.

2. Responsibilities and Planning

New legislation for SWPSs and boatswain's chairs came into effect on January 1, 2017. Changes to the Construction Projects regulation (213/91) include new requirements related to equipment, site-specific work plans, roof plans, set-up and training, and inspections and testing. These changes involve new responsibilities for workers, employers, constructors, and owners of the building or structure and the equipment. Here is a summary of the new regulatory requirements.

Equipment

- All SWPSs or powered boatswain's chairs, including all components and connections, must be designed by a professional engineer in accordance with:
 - CSA Standard Z271-10: Safety Code for Suspended Platforms (except clauses 6.1.1(b) and 6.1.2)
 - The "General Requirements: Design" section of the Construction Projects regulation (O. Reg. 213/91, s. 137).
 - Good engineering practice.
- A professional engineer must prepare a report to confirm that an SWPS meets the requirements of O. Reg. 213/91, s. 137 and 137.1 before it is used.
- The design drawings and report must be kept at the project and be available upon request.
- The employer (or supplier) who owns the SWPS must ensure that each of the following components has a unique identifier (O. Reg. 213/91, s. 141(2)):
 1. Truss
 2. End frame
 3. Stirrup
 4. Module connector
 5. Corner or angled section.

Work Plan

- Before using an SWPS or boatswain's chair for the first time at the project, the employer must ensure that a competent person has prepared rescue procedures, conducted a risk assessment, and prepared a site-specific work plan (see O. Reg. 213/91, s. 141.5).
- Before a worker uses or installs an SWPS or boatswain's chair, the employer must provide the worker with a copy of the work plan and review it with them.
- The work plan must be kept at the project and be available upon request.

Roof Plan

- Every owner of a building or structure where an SWPS or boatswain's chair is to be used must:
 - Ensure that there is a roof plan.
 - Ensure that the roof plan meets the requirements of O. Reg. 213/91, s. 141.2.
 - Post the plan near every entrance to the roof or top level where the SWPS or boatswain's chair is used.
 - Provide a copy of the roof plan to the constructor, who must make it available to employers who will use the equipment.
 - Ensure all fixed supports identified in the roof plan are inspected, maintained, and tested in accordance with the manufacturer's instructions, clause 11 (Inspection and Testing) of CSA Standard Z271-10, and section 141.4 of O. Reg. 213/91.

Set-up and Training

- An SWPS or boatswain's chair must be installed, used, and dismantled in accordance with the manufacturer's instructions and an installation drawing prepared according to the requirements of O. Reg. 213/91, sections 141.6, 141.7, and 141.8 (as applicable).
- A worker who uses an SWPS or boatswain's chair must have successfully completed a training course designed for SAE users. The proof of training must be available at the project. The worker must be retrained at least every three years (O. Reg. 213/91, s. 138).
- Only a designated competent worker can install, alter, or dismantle an SWPS or boatswain's chair (O. Reg. 213/91, s. 141.6). This worker must have successfully completed a training course designed for SAE installers. The proof of training must be available at the project. The worker must be retrained at least every three years (O. Reg. 213/91, s. 138.1).

Inspections and Testing

- Before using an SWPS or boatswain's chair for the first time at a project, the employer must ensure the entire system has been inspected, tested, and maintained in accordance with the manufacturer's instructions, CAN/CSA Z271-10 (clause 11: Inspection and Testing and clause 12: Maintenance), and the Construction Projects regulation (O. Reg. 213/91, s. 139(1)). The inspection, testing, and maintenance must be completed by a competent worker or a person with specific qualifications under CAN/CSA Z271-10.
- Before using an SWPS or boatswain's chair with a generic installation drawing for the first time (or if it is relocated at the project), a designated competent worker must inspect it (O. Reg. 213/91, s. 141.7). The worker must prepare a report of the inspection and must have successfully completed

a training course designed for SAE installers. The proof of training, installation drawing, and every report must be kept at the project and be available upon request. The worker must be retrained at least every three years (O. Reg. 213/91, s. 138.1).

- Before using an SWPS with a site-specific installation drawing for the first time, a professional engineer must inspect it and prepare a report (O. Reg. 213/91, s. 141.8). If the SWPS is relocated at the project, a professional engineer must approve of any deviations to the site-specific drawing. At the new location, either the designated competent worker (if there are no deviations) or a professional engineer (if there are deviations) can inspect the SWPS and prepare the report. The installation drawing, any approved deviations, and every report must be kept at the project and be available upon request.
- Each day before first use, a competent worker must inspect the SWPS or boatswain's chair and perform a functional test. Any defects or hazardous conditions must be identified and documented in writing. The inspection logs must comply with clause 13 (Equipment Log) of CSA Z271-10 and include a record of inspections, tests, repairs, modifications, and maintenance performed. The employer must keep a copy of these inspection logs and make them available upon request. (O. Reg. 213/91, s. 142.04)
- At least annually, a powered climber and components of an SWPS (as identified by the regulation and clause 11 of CSA Z271-10) must be tested. A representative sample of each type of structural component must be randomly selected for non-destructive testing (NDT) in accordance with section 139.1 (3) of O. Reg. 213/91.

3. Fall Protection

Every worker who uses SAE must have two independent means of support to protect them from falling. The first means of support is a fall protection system. The second is provided by the SWPS or boatswain's chair. This way, if one support system fails, the worker will be protected by the other support system.

In some cases, the second means of support can be an SWPS with two independent suspension systems. The platform would have two means of support and the workers would tie off directly to the platform in accordance with the engineers design and identified attachment points (see section 4.3.1).

3.1 Fall Protection Systems

The best way to protect workers from a fall is to stop the fall from happening. This type of fall protection system is known as **fall prevention** because it prevents a worker from falling. A fall prevention system uses devices such as guardrails,

covers over floor openings, warning barriers, and travel restraint to eliminate or minimize the possibility of a fall.

If fall prevention is not possible, the next best option is to use a fall protection system that prevents the worker from hitting the ground or an object below if they were to fall. This is known as fall arrest because it is designed to arrest (i.e., stop) the fall of a worker who is already falling. It includes fall restricting systems, fall arrest systems, and safety nets.

The preferred method of fall protection is to install guardrails. If that is not practicable, workers who may be exposed to a fall hazard must be protected by the highest-ranked method of fall protection that is practical (O. Reg. 213/91, s. 26.1(2)). These methods are ranked as:

1. Travel restraint system
2. Fall restricting system
3. Fall arrest system
4. Safety net.

Workers on a construction project who may use one of the four methods of fall protection listed above must complete a working at heights training course that has been approved by the Chief Prevention Officer (CPO) of Ontario (O. Reg. 287/13, s. 6-7). Workers must also receive training from their employer regarding the site-specific fall protection equipment and procedures they will use at each project (see section 3.4).

3.1.1 Fall Prevention

A fall prevention system (e.g., guardrails, warning barriers, travel restraint) is used primarily around areas on the roof where workers set up or take down SAE. It can also be used to protect workers on balconies or similar structures.

If a parapet wall meets the specifications of a guardrail (see O. Reg. 213/91, s. 26.3), workers can work near the edge of the roof without additional protection. However, if workers have to lean over or perform work beyond the parapet wall or if the wall does not meet the requirements of a guardrail (e.g., it's less than 0.9 m (3 ft) high), workers must wear appropriate fall protection equipment and be properly tied off (Figure 23-1).

A warning barrier (or bump line on a flat roof) can be set up 2 metres (6 1/2 feet) from a perimeter edge. Inside this cordoned-off area, workers are not exposed to a fall and do not require fall protection equipment.

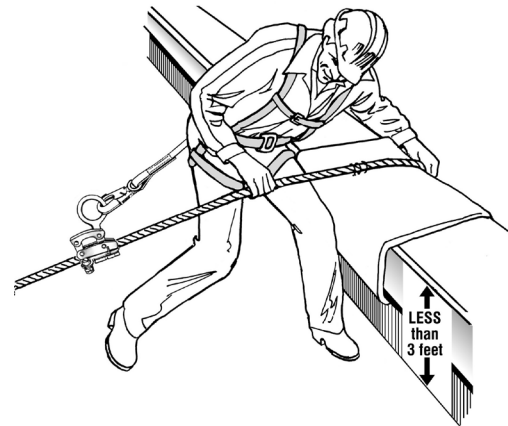

Figure 23-1: Fall Protection Required Near Parapet Wall Lower Than 0.9 m (3 ft)

Where no warning barrier or bump line is used, or where workers may be closer than 2 metres (6 1/2 feet) from the edge, a travel restraint or fall arrest system is required. Travel restraint is the preferred choice because it allows a worker to travel just far enough to reach the edge but not far enough to fall over it (Figure 23-2). For more information, refer to Chapter 19: Personal Fall Protection in this manual.

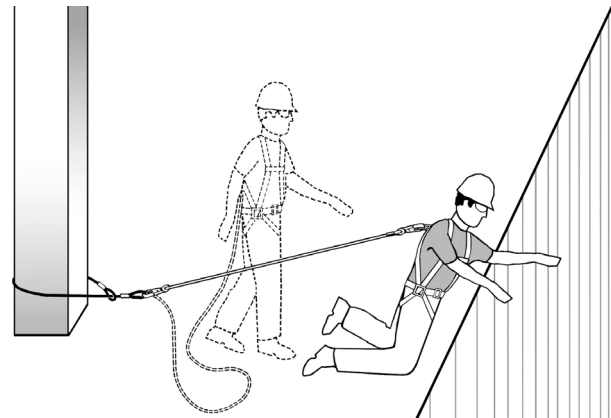

Figure 23-2: Travel Restraint System

3.1.2 Fall Arrest

In cases where a fall prevention system cannot be used, workers must use a fall arrest system (e.g., wear fall arrest or fall restricting equipment) to protect them from a fall.

A fall arrest system must be fully rigged, in place, and adjusted correctly. It must be properly attached to an adequate anchor or fixed support and be worn in the following situations:

- While setting up and taking down the SAE and working within 2 metres (6 1/2 feet) of the perimeter edge
- While getting on and off the SAE
- At all times while on the SAE.

3.2 Fall Protection Equipment

The equipment used for fall arrest is similar to the equipment for travel restraint. It generally consists of the following (Figure 23-3):

- A CSA-approved full-body harness connected by the D-ring on the harness to either a lanyard or an energy absorber attached to a lanyard
- A CSA-approved lanyard connected to a rope grab
- A CSA-approved rope grab connected to a vertical lifeline
- A CSA-approved lifeline connected to an adequate anchor point.

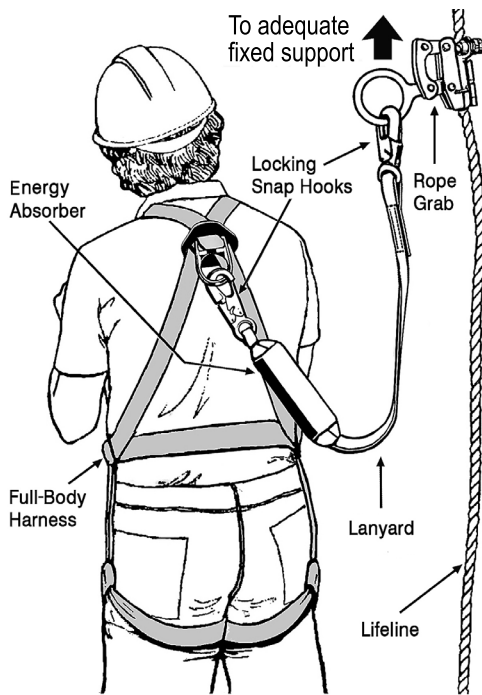

Figure 23-3: Fall Protection Equipment

In travel restraint, this equipment must prevent the worker from falling over the edge. In fall arrest, however, the equipment must prevent the worker from hitting the ground or an object below if they were to fall. To do this, the total fall distance must be known and the fall arrest equipment must be adjusted accordingly.

The total fall distance is the free-fall distance plus the fall stopping distance. For more information on calculating the total fall distance, refer to Chapter 19: Personal Fall Protection.

3.2.1 Fixed Supports (Anchors)

Fixed support means a permanent or temporary structure or a component that can withstand all loads and forces the structure or component is intended to support or resist and is sufficient to protect a worker's health and safety. It includes equipment or devices that are securely fastened to the structure or component (O. Reg. 213/91, s. 1).

Some examples of fixed supports (i.e., anchorage) can be found in section 4.3.12.

A permanent anchor system shall be used as the fixed support in a fall arrest system, fall restricting system, or travel restraint system if it is safe and practical to do so and it has been installed according to the building code (O. Reg. 213/91, s. 26.7(1)). Otherwise a temporary fixed support can be used.

All fixed supports must meet the requirements of section 26.7 of the Construction Projects regulation (as applicable). The design drawings for fixed supports must be approved by a professional engineer and they must be identified on the roof plan.

3.2.2 Lifelines

Vertical lifelines must meet or exceed the requirements for performance, durability, impact strength, and elasticity specified in the CSA Standard referenced in the Construction Projects regulation (i.e., CAN/CSA Z259.2.5: Fall Arresters and Vertical Lifelines).

Each worker on an SAE must have an individual lifeline attached to a separate anchor or fixed support. Do not attach lifelines to the same anchor point as outrigger beam tiebacks.

On new construction, lifelines usually can be secured to exposed structural components such as beams or columns. On existing buildings, fixed supports can include those listed in section 4.3.12.

Each lifeline must be long enough to reach the ground or a working level where a worker can exit from the equipment onto a solid, flat, level surface. Each fixed support or anchor must be separate and independent from those used for other lifelines and for tiebacks (Figure 23-4). Where there aren't enough independent fixed supports or anchors to meet this requirement, the system must be designed by a professional engineer.

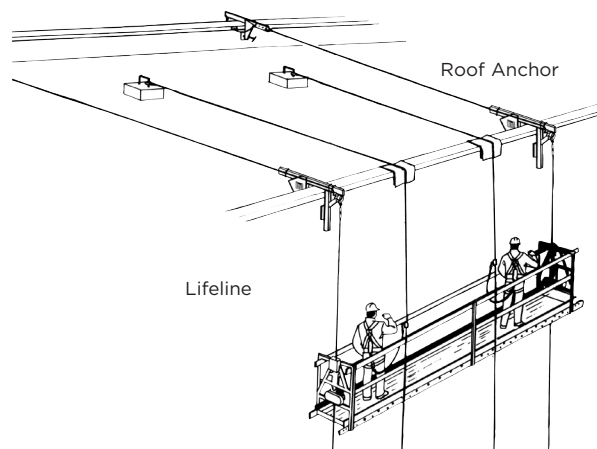

Figure 23-4: Lifelines Attached to Built-in Roof Anchors

Note: Screening on the SWPS is omitted for clarity.

Fibre rope lifelines are not permitted where caustic or acidic solutions or sprays will be used, as in building cleaning, or where sparks from welding or cutting can cause damage. In such situations, use wire rope lifelines and consult the manufacturer's guidelines and employer work plans. Wire rope lifelines should be insulated whenever electric welding is taking place.

3.2.3 Protection for Lifelines

Before each use, lifelines should be inspected for damage. Lifelines must be protected from abrasion or chafing and from sharp corners that can break the lines under heavy shock loads. A spliced eye and thimble, complete with a connector such as a self-locking snap hook or carabiner, is the recommended connection device. However, where the rope must be tied to the fixed support or anchorage, the rope should be doubled and a proven rope connection should be used such as a round turn and half-hitches or a triple bowline knot (Figure 23-5).

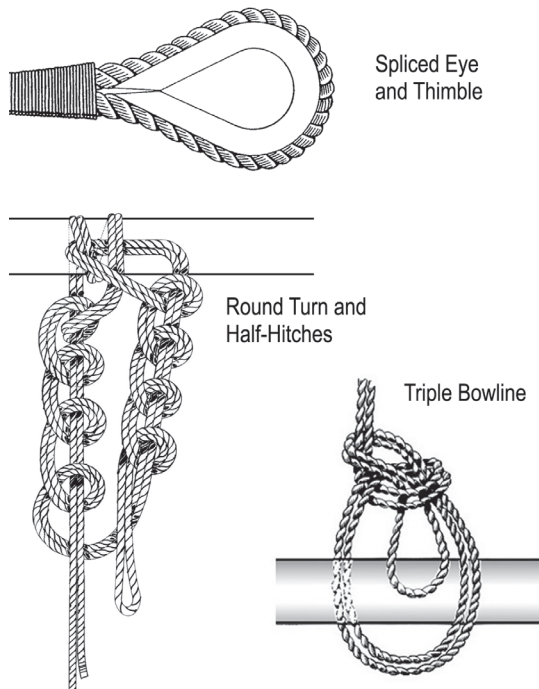

Figure 23-5: Protection for Lifelines

Although tying to the anchorage with knots is necessary in some situations, it is not recommended. Knots may reduce the load-carrying capacity of the rope significantly.

Lifelines must also be protected from abrasion where they pass over a parapet wall or the edge of a roof. A rubber hose clamped to the lifeline to hold it in position is an effective means of providing protection (Figure 23-6). Rubber mats or carpeting also provide protection but should be fixed to the lifeline or be wide enough to allow for considerable shifting of the lifeline because of wind or movement of the worker (See Figure 23-1).



Figure 23-6: Rubber Hose Clamped to Lifeline

The lifelines should be reasonably taut. Loose coils on the roof should be rolled up to prevent a tripping hazard. Lifeline anchors should be as perpendicular as possible to the roof edge at the point where the lifelines drop over. The anchor point should be a reasonable distance from the roof edge—preferably 3 m (10 ft) or more. This will allow the rope to absorb more energy in the event of a fall arrest at the roof edge.

Lifelines must also be protected from entanglement in traffic on the ground below or in construction equipment such as tower cranes. This can be done by fencing off the area underneath and limiting access or by tying the lifeline to the structure at ground level or weighting it down with counterweights (Figure 23-7). Always allow enough slack for the movement of workers on the stage.

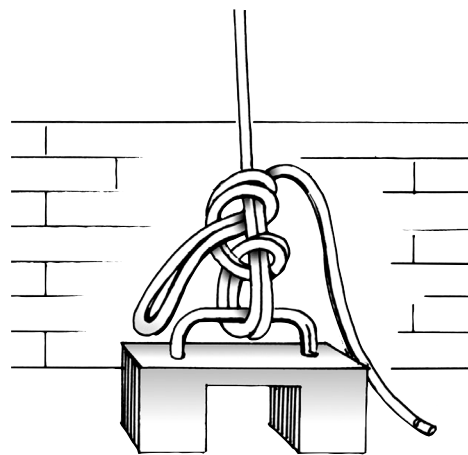

Figure 23-7: Lifeline Secured to Counterweight at Ground Level

3.2.4 Lanyards and Rope Grabs

Section 26.1(3) of the Construction Projects regulation (213/91) requires that lanyards meet or exceed the requirements of CAN/CSA-Z259.11-05. Lanyards are attached to the lifeline by a rope grab. Rope grabs and lanyards must be attached by a self-locking snap hook (Figure 23-8), a carabiner looped through a spliced loop and thimble, or a loop and thimble spliced into the rope grab ring. These methods will prevent "roll-out." Looping a splice around a D-ring is **not** recommended.



Figure 23-8:
Self-Locking
Snap Hook

Unless working in travel restraint, an energy absorber is attached to (or is part of) the lanyard and is connected to the full-body harness through a self-locking snap hook on the D-ring. Energy absorbers should be used in any fall arrest system unless it may cause the user to hit the ground or objects below. Energy absorbers must meet CAN/CSA Z259.11-05 and carry the CSA label. Note: A typical energy absorber can add 1.2 metres (4 feet) or more to the fall distance before the fall is arrested. Check the deployment length for the energy absorber you will be using.

3.2.5 Full-Body Harness

It is a legal requirement in Ontario to wear a full-body harness with SAE—not a safety belt. During a fall arrest, the harness absorbs the weight of the body at the thighs and buttocks rather than the upper abdomen and chest where many of the body's vital organs are located.

3.3 Fall Protection Planning

A pre-job risk assessment must be done to determine not only the type of SAE to be used but also the type of fall protection needed. When assessing fall protection requirements, consider the following points.

1. What are the fall hazards? Rank these hazards in terms of likelihood and severity and take steps to control or eliminate them.
2. Is there a parapet wall around the roof perimeter that meets the requirements of a guardrail?
3. Are engineered anchors installed on the roof? How many are there? Where are they located? How far are they from the set-up area?
4. If there are no engineered anchors, are any existing structures or fixed supports adequate to serve as anchors?
5. Are there any sharp edges requiring lifelines to be protected?

Fall protection planning must include:

- The type of fall protection equipment to be used
- The type, length, and number of lifelines required
- Travel restraint or warning barriers to be used when setting up or dismantling the suspended access system on the roof
- Fall protection procedures to follow while setting up, getting on, getting off, working from, and dismantling the SAE.

In addition, all horizontal and vertical work surfaces where the SAE will be assembled, operated, and dismantled must be evaluated to determine escape, rescue, and other emergency procedures in the event of a mechanical failure or breakdown.

3.3.1 Fall Arrest Rescue Planning

A fall arrest system does not prevent a fall, but it can reduce the severity of injury from a fall by preventing a falling worker from hitting the ground or any object or level below the work.

Before any fall arrest equipment is used on a construction project, the employer is legally required to have in place a written procedure outlining how to rescue a worker involved in a fall arrest (O. Reg. 213/91, s. 26.1(4)). Before using an SWPS or boatswain's chair for the first time, the employer must also ensure that a competent worker prepares written procedures for rescuing a worker from the SAE (O. Reg. 213/91, s. 141.5(1)). This is in addition to the procedures required by law to cover any general emergency response on a project (O. Reg. 213/91, s. 17(1)).

A worker hanging in harness after a fall arrest must be rescued and brought to a stable work surface, platform, or ground as soon as possible (preferably within 30 minutes). If left suspended for a prolonged period of time, the worker may experience nausea, dizziness, heart problems, and breathing difficulties. This can cause fainting or may lead to a fatality. This condition is called suspension trauma.

To ensure timely, effective rescue, an employer may create generic procedures to cover all potential fall rescue requirements for the company's typical work. The employer must then:

- Provide staff training in the procedures
- Ensure that the procedures are reviewed and modified as necessary to meet specific job conditions
- Provide staff training in these modified, site-specific procedures.

Use the **Emergency Procedures for Fall Rescue** in Chapter 2: Emergency Procedures to prepare rescue procedures for workers involved in fall arrest.

3.4 Fall Protection Training

Employers must ensure that any worker who may use a fall protection system is properly trained in its use and given adequate oral and written instructions by a competent person.

Workers in Ontario must receive working at heights (WAH) training from a training provider approved by the Prevention Office of the MOL. This classroom-based training must be followed by site-specific training at the jobsite. The approved WAH training must be refreshed every three years. Employers must keep written records of all employees trained in WAH and have them readily available upon request.

4 Suspended Access Equipment

4.1 Equipment Types, Limitations, and Applications

Equipment discussed in this section is restricted to manufactured suspended work platform systems (SWPSs), work cages, and boatswain's (or bosu525n's) chairs. Unusual or non-conventional arrangements of equipment must be reviewed by a professional engineer to ensure compliance with applicable standards, regulations, and good practice (O. Reg. 213/91, s. 141.8). In addition, a professional engineer must confirm that any SWPS designed before January 1, 2017, meets the structural integrity requirements of the new regulations found in O. Reg. 231/19, s. 137 and 137.1.

4.1.1 Installation Drawings

SAE must be erected, installed, used, and dismantled according to the manufacturer's instructions and a generic installation drawing. However, some SWPSs may require a site-specific installation drawing if some of the requirements of the generic drawing cannot be met or in the following circumstances:

1. If there will be stacked or tiered work platforms.
2. If there will be a work platform that, including its components, weighs more than 525 kg (1/2 ton).
3. If there will be a work platform that has a span greater than 12 m (39 ft) between adjacent points of suspension.
4. If there will be a work platform that has more than two primary suspension lines.
5. If more than two hoisting devices will be used to move a work platform.
6. If there will be a work platform that has any shielding, tarpaulin, enclosure, sign, or banner on it that may increase the wind loads on the components of the SWPS.
7. If the vertical distance between the top of a suspension line and the lowest point on the street, ground or other horizontal surface under a work platform will exceed 150 m (490 ft). (O. Reg. 213/91, s. 141.6(3))

4.1.2 SWPS with Manual Traction Climber

This type of equipment is suitable for working at moderate heights and in situations where only limited climbing is required and where the SWPS will remain in the same position for an extended period of time (Figure 23-9). For many years, this was the most popular type of SWPS in the industry. More recently, it has been replaced by various types of powered climbers, especially at heights of more than 100 feet or where a lot of movement is required.

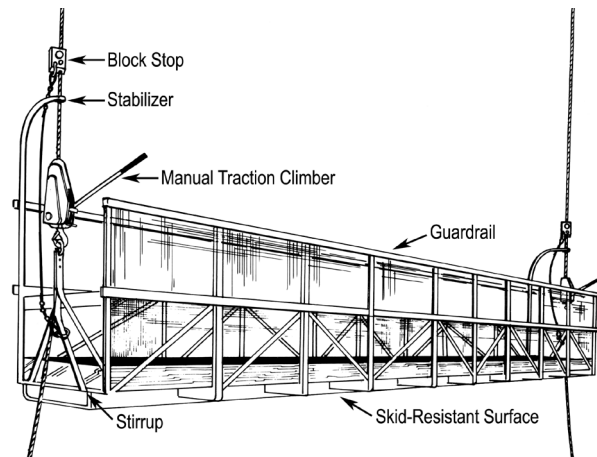

Figure 23-9: Manual Traction Climber

4.1.3 SWPS with Drill-Powered Traction Climber

The climbers on these devices are powered by specially designed electric drills (Figure 23-10). One advantage is that they operate on a 120-volt power supply. This eliminates the requirement for special 220-volt wiring commonly required on larger powered climbers. A disadvantage is that the rate of climb is somewhat slower than for other types of powered climbers.

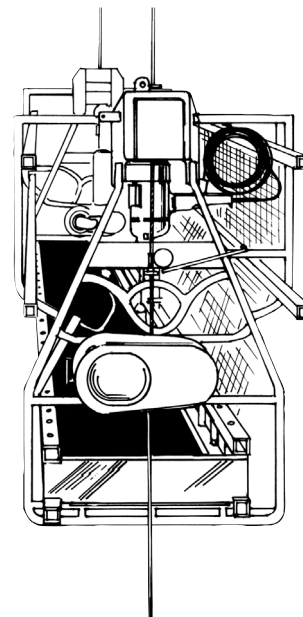

Figure 23-10: Drill-Powered Traction Climber

The drills that power these climbers can be easily removed and stored when not in use, eliminating some of the weather damage and vandalism that can occur when climbing devices are left outdoors.

4.1.4 SWPS with Powered Traction Climber

This is the most common type of powered climber in use today (Figure 23-11). Its fast rate of climb makes it ideal where vertical distances are large or frequent movement is required. Usually powered by a 220-volt power source, the unit may require installation of a temporary electrical supply depending on location. However, pneumatic (air-powered) climbers are also available.

Because of the relatively fast rate of ascent and descent (up to 35 ft/min), operators must take care that the stage does not catch on obstructions such as architectural features and overload the suspension system. This caution, of course, applies to all devices but is most important where climbers operate at greater speeds.

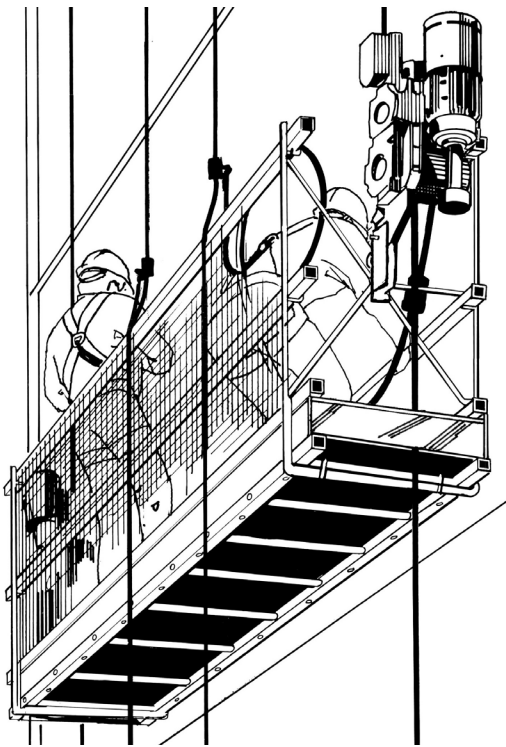

Figure 23-11: Powered Traction Climber

4.1.5 SWPS with Powered Drum Hoist Climber

This equipment is common in the industry today (Figure 23-12). One advantage is that the suspension lines are wound up on the drum of a hoist rather than extending to the ground. This keeps the free ends of suspension lines from crossing, catching on the building, entangling, or otherwise hindering safe operation. This feature improves the safety of the equipment. Although not common, other types of climbers can be equipped with a reel to provide the same feature.

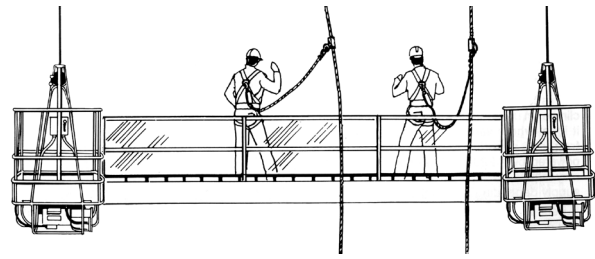

Figure 23-12: Powered Drum Hoist Climber

Note: Screening on the SWPS is omitted for clarity.

4.1.6 Boatswain's Chair

Boatswain's (or bosun's) chairs were used for centuries on ships (Figure 23-13). Originally equipped with a rope fall, the chairs required considerable physical effort to be raised and lowered.

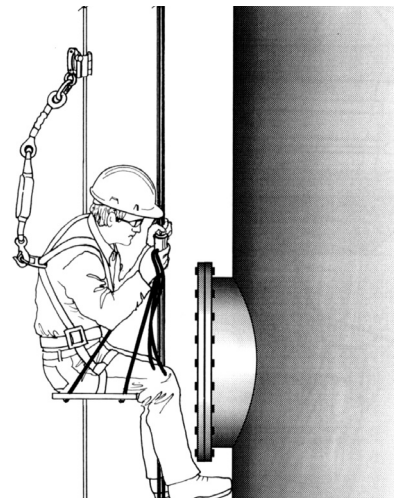

Figure 23-13: Boatswain's Chair

Today, with descent control devices or powered climbers, boatswain's chairs can be used for various purposes in construction, repair, maintenance, and inspection. In some cases, it may be safer and more efficient to use work cages equipped with powered climbers.

Whether equipped with a descent control device or powered climber, all boatswain's chairs must use wire rope support cables if any of the following circumstances exist:

- The distance from the fixed support to the work platform will exceed 90 metres (295 feet).
- Corrosive substances are used near the support cables.
- Grinding or flame-cutting devices are used near the support cables.

As with all SAE, a fall arrest system must be worn at all times when getting on, working from, or getting off a boatswain's chair. For more information on fall arrest, see section 3 or Chapter 19: Personal Fall Protection.

4.1.7 Boatswain's Chair with Descent Control Device

This arrangement is commonly used by window cleaners (Figure 23-14). It is very useful in situations where workers must progressively descend from one level to another. However, it cannot be used to climb.

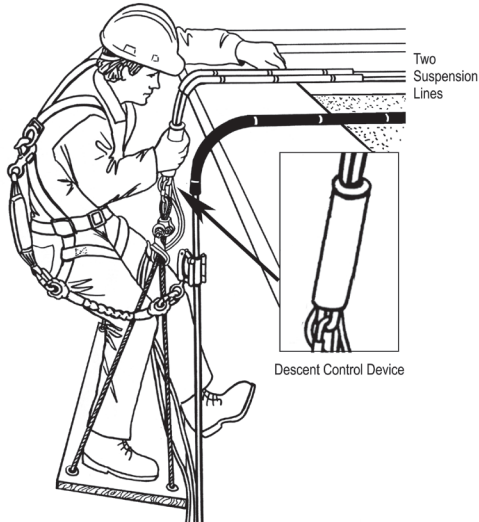

Figure 23-14: Boatswain's Chair with Descent Control Device

The main advantage of descent control devices is that they are light to carry or move and simple to rig. Such devices must be used with two suspension lines because the ropes are easily damaged. The second suspension line provides added safety. Note: Two suspension lines are required by both the Construction Projects (213/91) and Window Cleaning (859) regulations.

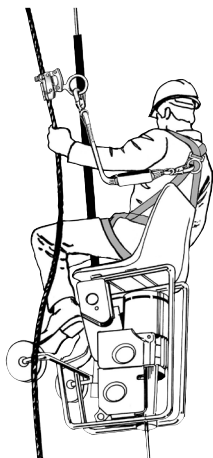

Figure 23-15: Boatswain's Chair with Powered Climber

4.1.8 Boatswain's Chair with Powered Climber

These devices are fitted with a seat attached to a powered climber unit (Figure 23-15). They are often used for work that requires a considerable amount of travel in restricted areas where powered work cages would be cumbersome. They are compact in size and generally lighter than work cages. Inspection work is a typical application for these devices.

4.1.9 Work Cage with Powered Climber

In construction, work cages are often used in place of boatswain's chairs for both safety and efficiency (Figure 23-16). These devices are usually equipped with powered climbers similar to those used for stages. Some of the devices fold up for easy transport. Others may be equipped with platform extensions providing a wider working area.

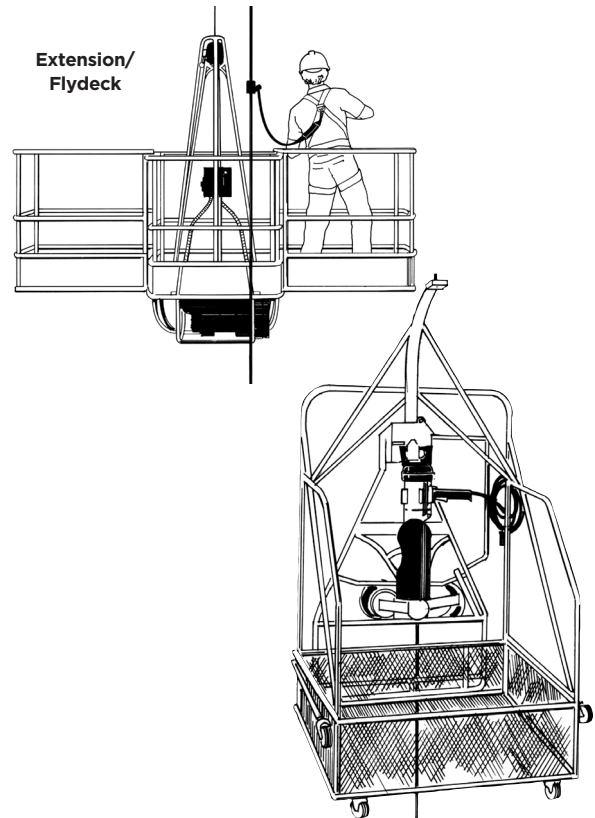

Figure 23-16: Types of Work Cages

4.1.10 Permanent Work Platform System

Some large-scale buildings or structures have work platforms that are permanently installed in order to allow workers easy and safe access to the outside surface. For permanent devices such as building maintenance units (BMUs) or roof cars, the hoisting machine is located on the roof and the wire rope unwinds from there. For Davit-type systems, a built-in wire winder is located on the platform. Workers on these types of permanent systems usually tie off to horizontal lifelines installed on the platforms.

4.2 Components and Rigging

4.2.1 Platforms

Load ratings of various types of SWPS and platform combinations are available from manufacturers. The employer must ensure that the rated capacity of the platform is posted conspicuously on the SWPS or boatswain's chair (O. Reg. 213/91, s. 142). Typical platforms have a capacity range of 500 to 1,500 lb (220-680 kg).

The platform must be capable of supporting all loads to which it is likely to be subjected without exceeding the manufacturer's rated working load. The load includes equipment and materials hanging from the SWPS. We strongly recommend that only platforms rated for 750 lb or greater be used on construction projects.

Each platform should be equipped with the following:

- An adequate guardrail system all around the platform that includes
 - a securely attached top rail between 0.9 metres (36 inches) and 1.1 metres (43 inches) above the work platform
 - a securely attached mid-rail
 - toeboards
- A screen to prevent small objects (i.e., diameter less than 25 mm (1 in)) from falling off. This screen must meet the requirements of section 6.4.5 of CAN/CSA Z271-10 and the wind load requirements of O. Reg 213/91, s. 141.6(3)6.
- A skid-resistant platform
- Stirrups that are adequately sized and securely attached.

The front guardrails must be in the fully raised position at all times while the SWPS is being raised or lowered. If the SWPS is less than 30 cm (12 in) from the facade and properly secured to the face of the structure (i.e., not moving), the front guardrails can be lowered to accommodate the work being done. Additional care should be taken to tether tools and material during this process.

Stock platforms are available from most suppliers from 4 feet to 32 feet long in increments of 2 feet. Various combinations of shorter modular platforms are designed to be connected together (Figure 23-17). Use only manufacturer-designed connection methods.

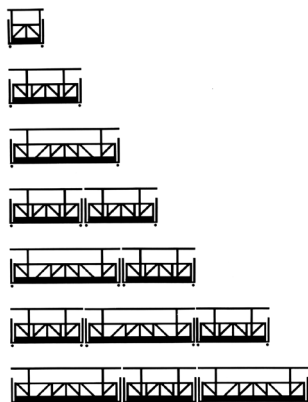

Figure 23-17: Typical Platform Modules

To ensure that the SWPS remains close to the facade during work, it must be secured to the building wherever possible, unless it is being raised or lowered.

The screen must have openings no larger than 25 mm (1 in). It should be in good condition and fastened in position to cover the area from top rail to toeboard. This will prevent debris and tools from falling off the platform and injuring people below.

4.2.2 Safety Devices

Various platform accessories are available from suppliers to improve safety and operation. For example, guides or wire rope stabilizers attached to the stirrups will reduce platform sway, ground castors on the bottom of the platform will make horizontal movement easier, and bumper or guide rollers attached to the front of the platform will provide clearance around small obstacles and protect the building face (Figure 23-18).

Stirrups must be securely attached to the platform. This is usually done with a threaded rod or bolts. These should be equipped with lock nuts or drilled and fitted with locking pins.

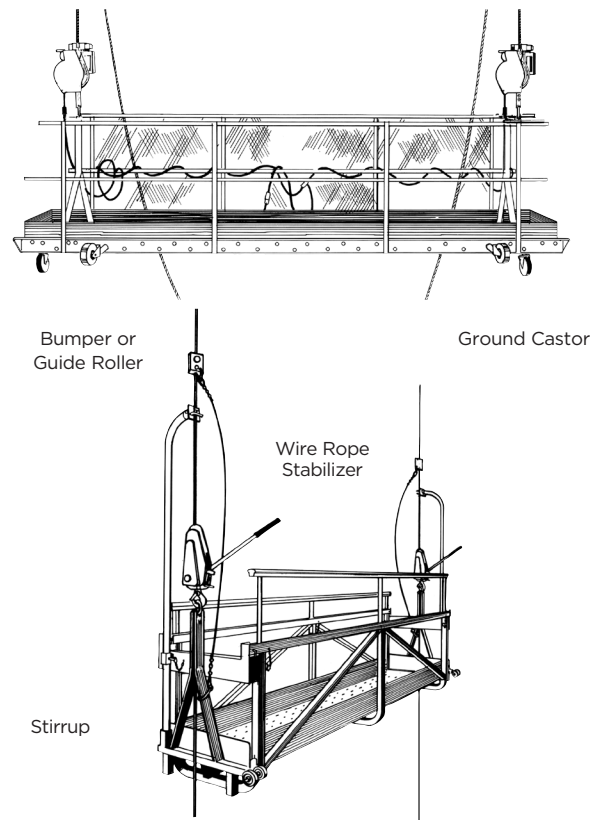

Figure 23-18: Safety Devices

Special adjustable roller or castor systems are available for platforms used on sloping surfaces (Figure 23-19). This type of set-up should only be used if the supplier of the SWSP agrees to the alterations. The alterations must be made in accordance with manufacturers' recommendations and the site-specific installation drawings done by a professional engineer.

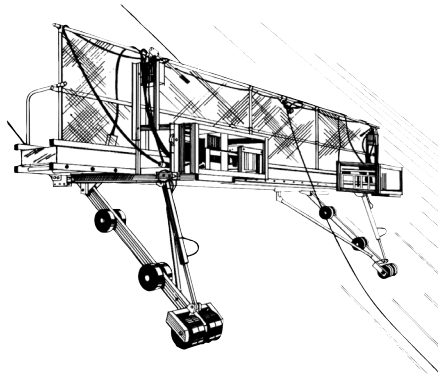

Figure 23-19: SWPS with Castors for Sloped Roof

An SWPS must be secured to the building wherever possible, unless it is being raised or lowered. Newer buildings are equipped with mullion guides. Devices attached to the stage slide up and down the guides to reduce lateral movement. Magnets, suction cups, tethers, or slings have been used to secure the SWPS to the building for construction applications. Refer to the instructions in your employer's work plan.

Most SWPSs are manufactured from aluminum components. This makes them strong but also lightweight and easy to handle. However, aluminum platforms are not recommended where caustic or acidic materials and fumes may be encountered. In these instances, special provisions must be made to protect the platform from the particular hazardous substance.

Where aluminum platforms are exposed to caustic or acidic conditions, they should be rinsed off with clean water regularly and inspected regularly for signs of degradation or damage. Aluminum stages may be given a protective coating.

4.2.3 Outrigger Beams

Various types of outrigger beams are available in the construction industry. Most beams are steel while others are aluminum. They have two or three sectional components to keep them light and portable.

These beams are not indestructible and should be used only in accordance with the manufacturer's or supplier's table of counterweights and allowable projections beyond the fulcrum (i.e., tipping point) for various suspension line loads. Adequate legible instructions for the use of counterweights must be affixed to the outrigger beam.

It must be understood that **outrigger beams have maximum allowable projections beyond the tipping point (fulcrum) due to strength limitations.** This information must be provided on the label or in the instructions.

Sectional outrigger beams must have a means of preventing pins from loosening and falling out (Figure 23-20). Otherwise, pins can work loose with

movement of the stage and action of the climbers. Beams must be free of any damages, cracking, corrosion, bends, etc. since these can reduce structural capacity considerably.

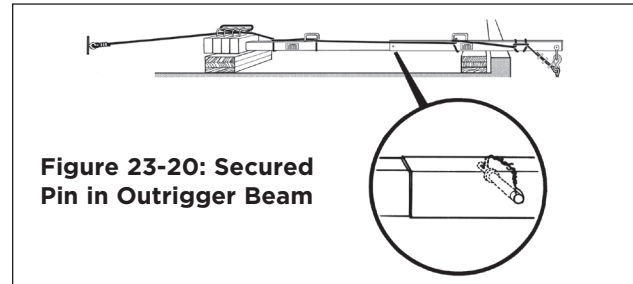

Figure 23-20: Secured Pin in Outrigger Beam

4.2.4 Counterweights

Counterweights range from 30 to 75 lb each. Only manufactured counterweights compatible with the outrigger beam should be used. The counterweights must have a means of being secured in place on the beam. An adequate number of counterweights must be available to provide the counterweight capacity required for the beam projection beyond the fulcrum (see Section 4.3).

4.2.5 Wire Rope

Wire rope may be used as suspension lines or tieback lines for outrigger beams. For suspension lines on any type of hoisting equipment, use only wire rope of the type, size, construction, and grade recommended by the manufacturer of the climbing unit. The most common size of steel wire rope used for climbing devices on SAE is 7.8 mm (5/16 in) diameter.

The compressibility of the fibre core can cause the rope to slip through the traction climber. So manual traction climbers will generally use wire rope of a stiffer construction than powered climbers. Always consult the manufacturer's instructions when selecting the type of wire rope.

Wire ropes should be free of kinks, birdcaging, excessive wear, broken wires, flat spots, or other defects (Figure 23-21).

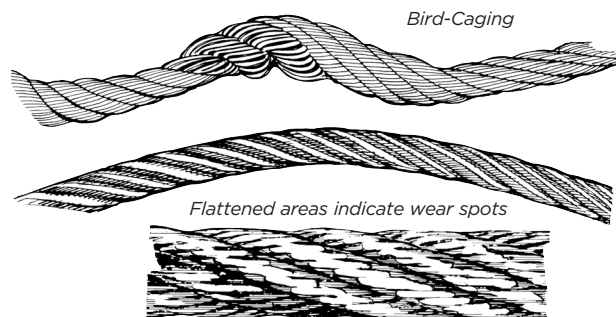

Figure 23-21: Wire Rope Defects

Wire ropes used with SAE must have a safety factor of 10 against failure (the manufacturer's catalogue breaking strength). This applies to all wire ropes used in rigging the equipment, including suspension lines and tiebacks. In both cases, the wire rope must be properly secured to adequate anchorage.

There are many types of wire rope end fittings or terminations. They include wire rope clips, swaged socket and poured socket terminations, spliced eye terminations, and turnback eye terminations. Before being used for the first time, all terminations of the wire rope suspension lines must be tested in accordance with the manufacturer's recommendations and the requirements of O. Reg. 213/91, s. 142.02. A record of these tests must be kept on the project and available upon request.

If using wire rope clips as a termination, make sure you're using the correct type. Although U-bolt clips are common, double saddle clips (sometimes called J-clips or fist grip clips) are now required for SAE because they are easier to install correctly, they cause less damage to the wire rope, and they are more appropriate for this application (Figure 23-22).

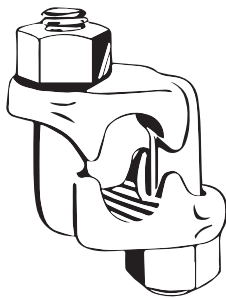

Figure 23-22: J-Clip or Fist Grip Clip

Wire rope clips must never be used on fibre or synthetic rope unless the procedure is authorized by the rope manufacturer.

Never use any type of clip to directly connect two straight lengths of wire rope. Instead, use the clips to form an eye (with thimble) in each length and connect the eyes together (Figure 23-23).

Clips used with wire rope tiebacks or static lines should be the right size and number and correctly torqued and installed. Table 23-1 specifies the number of clips required for various types and sizes of wire rope commonly used for tiebacks and static lines.

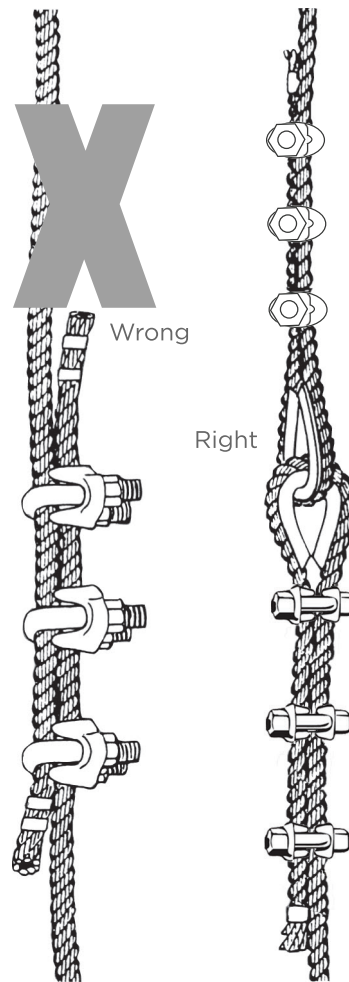

Figure 23-23: Joining Wire Ropes

Table 23-1: Sample Guide for Installing Wire Rope Clips

Rope Diameter (inches)	Minimum Number of Clips	Amount of Rope Turn Back From Thimble (inches)	Torque in Foot-Pounds Unlubricated Bolts
5/16	3	11-1/2	30
3/8	3	11-1/2	45
7/16	3	11-1/2	65
1/2	3	11-1/2	65
9/16	3	12	95
5/8	3	12	95
3/4	4	18	130
7/8	4	19	225

Note: This is only a sample guide. Always refer to the manufacturer's instructions.

Method for Installing Wire Rope Clips

Step 1: Apply First Clip

- Apply first clip one base width from dead end of wire rope.
- Turn nuts firmly. **DO NOT TIGHTEN.**

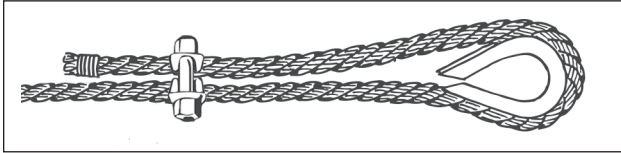

Step 2: Apply Second Clip

- Apply second clip as close to loop as possible.
- Turn nuts firmly. **DO NOT TIGHTEN.**

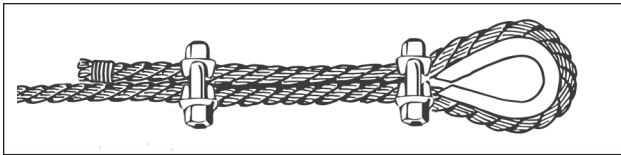

Step 3: Apply All Other Clips

- Apply all other clips spaced evenly between the first and second clip.
- Torque as per manufacturer's instructions.

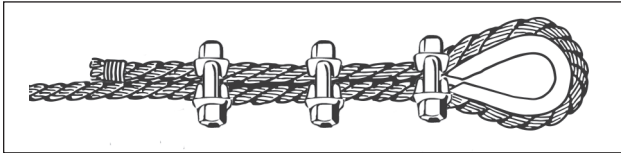

Step 4: Apply Tension

- Apply tension for intended load and tighten all nuts to recommended torque.
- Check nut torque after rope has been in operation.

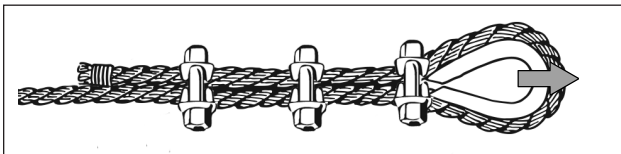

In case a wire rope connection fails, use a secondary safety device—commonly known as “block stop”. These devices must be installed, used, inspected, and maintained according to manufacturer’s instructions.

Wire rope suspension lines supporting a stage used for electric welding must be protected from the danger of welding current passing through them. This can be done by using an insulated thimble on the suspension line/outrigger beam connections and covering the climber and suspension lines near the SWPS with an insulating material such as a rubber blanket. The ground connection for the material being welded should be as close as possible to the welding zone. The SWPS should have rubber bumpers and the deck and rails should be covered with insulating rubber.

4.2.6 Rigging Hardware

Rigging hardware used with SAE must have a 10:1 safety factor (i.e., be capable of supporting at least 10 times the maximum load). This applies to all hooks, shackles, rings, bolts, slings, chains, wire rope, and splices.

Shackles and hooks should be made of forged alloy steel. The maximum capacity of these devices is usually

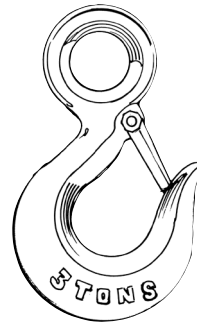

Figure 23-24: Forged Alloy Hook with Stamped Capacity

based on a design factor of 5 and is stamped on the device (Figure 23-24).

A safety factor of 10 is required for rigging used with SAE. Therefore, when the equipment has a design factor of 5, it’s capacity must be divided in half to ensure a safety factor of 10. This means that a 3-ton hook can only be used to hoist up to 1.5 tons when used with SAE.

$$3 \text{ tons} \div 5 \text{ (design factor)} = 1.5 \text{ tons (capacity at 10:1)} \\ 10 \text{ (safety factor)}$$

4.2.7 Manual Traction Climbers

The mechanical action of these devices is similar to hand-over-hand pulling on a rope. While one mechanism pulls, the other changes position to pull in turn. The jaws of the device grip the wire without damaging it. They are self-locking. As the load increases, their grip increases—the greater the load the tighter the grip.

Lifting capacity varies with the size of the device. Check the manufacturer’s literature to ensure that the capacity is adequate for the load. A maximum load rating for pulling and maximum load rating for hoisting will usually be specified in the literature. Use the load rating for hoisting.

Only the size, type, construction, and grade of wire rope specified by the manufacturer should be used with these climbers. Maintenance is usually a daily inspection and periodic cleaning as per the site-specific work plan. Repairs should be left to an authorized dealer with factory-trained personnel.

4.2.8 Secondary Safety Devices

In addition to the lifeline and rope grab, a block stop can be used as a secondary safety device to provide protection in case the wire rope connection or primary hoisting system fails. Figure 23-25 illustrates how the block stop is mounted on each wire rope above the hoist with a whip or sling connected to the stirrup of the stage. They may also be a fixed component on powered climbers.

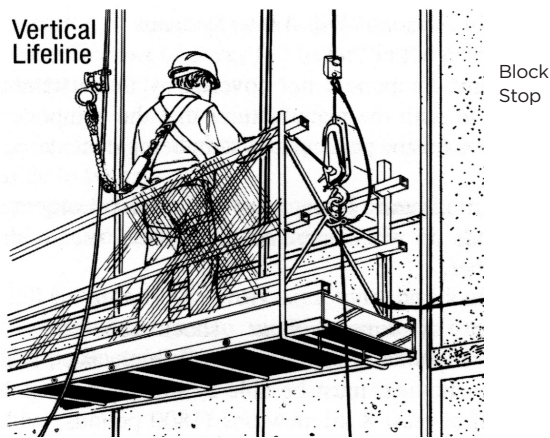

Figure 23-25: SWPS with Secondary Safety Device

As these devices advance on the wire rope, their jaws open slightly to let the rope pass through. When a sharp downward pull is exerted, the jaws automatically close on the rope and grip it with a degree of tightness determined by the load.

4.2.9 Powered Climbers

Powered climbers come in a variety of sizes with different climbing speeds, power requirements, and safety devices. Most are powered by electricity. Some operate at 115 volts, 60 Hertz, while others operate at 220 volts, 60 Hertz. Air-powered and hydraulic-powered systems are also available.

Powered climbers have automatic overspeed brakes for situations where descent takes place too quickly. In addition, all SWPSs must have a device that automatically stops them if the hoist is loaded beyond its normal limit, if it fails, or if the power is interrupted.

Most also have a manual system for lowering the SWPS in case of power failure or other emergency. Workers using the SWPS should be fully instructed in the operation and purpose of these devices.

Manufacturers usually list a safe working load either on the device or in their manual. Along with this information, the climbing speed will usually be noted. Climber lifting capacities range from 304 to 1,134 kg (750 to 2,500 lb) and climbing speeds vary from 0.178 to 0.76 metres per second (15 to 35 ft/min). Do not exceed the rated working load of either of the two climbers on your stage. To ensure that you are not overloading the climbers, take the combined total of:

- a) half of the weight of the SWPS, motors, climbers, and power cables

PLUS

- b) the full weight of all the people, working materials, tools, equipment, and anything else that the SWPS may carry.

This combined total must not exceed the manufacturer's rated working load of each of the climbers taken alone.

Before selecting an electrically powered climbing device for a particular application, a competent person or licensed electrician must determine what circuits are available at the site. If circuits do not meet the voltage and amperage required, temporary wiring will be necessary to accommodate the climbers. Where the wiring runs are long, voltage drops may occur. A booster is needed to maintain current levels so that the motor will not overheat.

Also consider the amount of climbing necessary for the job. Climbing speeds vary with the size of the climber. Small climbers carrying loads up near their safe working load limits over large distances may overheat and automatically cut off power. Make sure the proper climber is used for the job.

Use power supply cords with heavy gauge wire that meets the requirements set out by the equipment supplier. Twist-lock outdoor male and female connectors should be used. Strain-relief or "sock" supporting devices must be used to relieve the strain on connections (Figure 23-26). Water-tight "boots" must also be used in outdoor or wet locations.

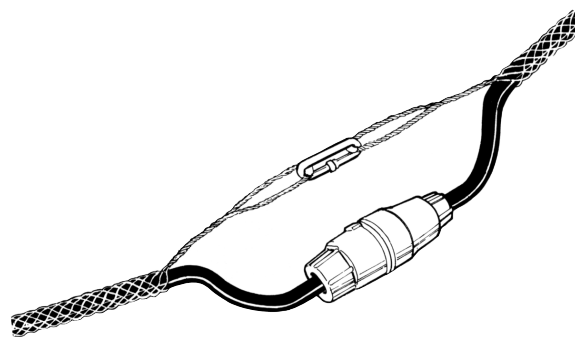

Figure 23-26: Strain Reliever/Sock Supporting Device

4.3 Set-Up and Operation

Changes to the Construction Projects regulation (213/91) require that a competent worker who is designated by the employer to install or dismantle and inspect an SWPS must complete a training course specifically designed for SAE installation and inspection. See section 2: **Responsibilities and Planning** for more information.

4.3.1 Two Independent Means of Support

As mentioned in section 3, all workers on an SAE must have two independent means of support to protect against a fall.

The first means of support for the worker is a fall protection system, which usually consists of a full-body harness, energy absorber, lanyard, rope grab, and lifeline secured to adequate anchorage.

The second means of support is the SWPS or boatswain's chair, which usually consists of climbers, suspension lines, outrigger beams, tiebacks and counterweights or parapet clamps secured to adequate anchorage.

An alternative method for providing a second means of support is a second complete and independent suspension system (Figure 23-27).

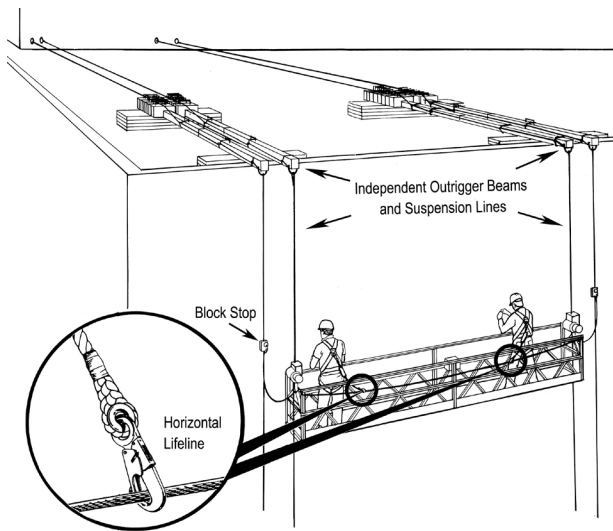

Figure 23-27: Two Independent Means of Support for SWPS

In this case, there are four outrigger beams and suspension lines instead of two supporting the SWPS. If one fails, the others will support the platform. The workers on the platform must still wear a fall arrest system but they would tie off to an anchor point on the SWPS. This anchor point must be approved by an engineer. It can include a properly designed horizontal lifeline securely fastened to both stirrups.

This type of secondary suspension system must be designed by a professional engineer. In practice, two complete suspension systems are not used unless the application involves a tiered SWPS (Figure 23-28).

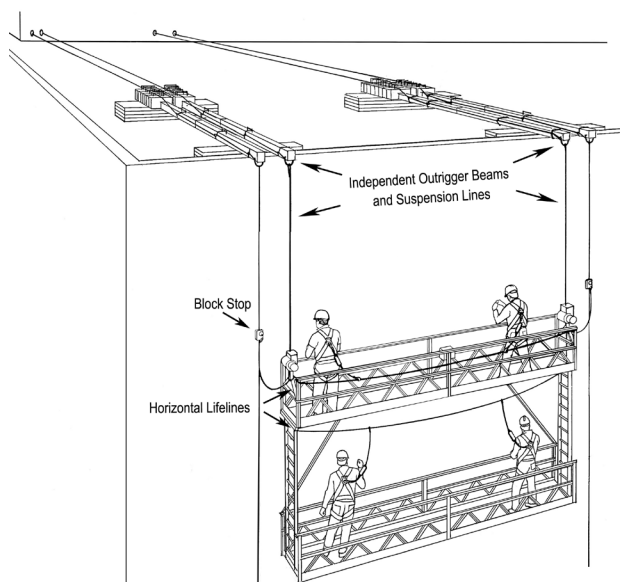

Figure 23-28: Tiered SWPS

In this case, workers on the lower platform could not adequately be protected by a lifeline if the upper platform were to fall. Therefore, both platforms are supported by two independent support systems.

Workers on the lower platform must tie off to the level they are on or to the one above. Workers on the upper platform may tie off to the level they are on or a lifeline.

A tiered SWPS must not be used unless the system is designed for the specific application by a professional engineer familiar with this type of equipment. The system must be rigged according to the design. Drawings of the design must be kept on site for easy reference and inspection. In addition, the rigging should be checked by a professional engineer before it is put into service for the first time.

4.3.2 Outrigger Beams, Counterweights, and Tiebacks

Outrigger beams may be used for either SWPSs or boatswain's chairs. Procedures for both are essentially the same and in both cases the instructions on counterweight requirements and overhang limitations must be affixed to the outrigger beam being used.

Beams must be:

- Counterweighted to maintain a 4-to-1 safety factor against overturning or failure
- Tied back to adequate anchorage
- Firmly attached to the counterweights
- Free of damage, kinks, or sharp edges
- Light enough to be manually handled and transported.

4.3.3 Counterweights and 4-to-1 Safety Factor

A dynamic load (i.e., a load that is moving) is greater than a static or stationary load. We have all caught something dropped to us. When something is moving, it is heavier when we catch it than when we simply hold it. The dynamic loads involved and the unforgiving nature of SAE require that the outrigger beam/counterweight arrangement must have a safety factor of 4 against overturning.

According to the law of the lever, the "tipping effect" or "moment" is equal to the load multiplied by the length of the lever. We have all used a pry bar to move heavy objects. The longer the bar, the easier it is to move the heavy object, or the heavier the person on the bar, the easier it is to move the object.

This means that the tipping tendency holding the beam from overturning must be at least 4 times the tipping tendency created by the suspension line load acting on the beam.

Each outrigger beam must have adequate legible instructions from the manufacturer for using counterweights. These instructions will state the number of counterweights you need for a given loading and overhang situation.

This information applies only to the specific beam and counterweights provided by the manufacturer for use with that particular system. If the information is missing or illegible, do not attempt to calculate the number of counterweights needed.

4.3.4 Suspension Line Load with Powered Climbers

For both SWPSs and boatswain's chairs operated by powered climbers, the line load used to calculate the number of counterweights is the same as the manufacturer's rated capacity of the climber. The rated capacity must be posted conspicuously on the climber and must match the load limit information on the outrigger beams.

Powered climbers operate at speeds up to 35 feet per minute. If a platform or chair gets caught on an obstruction, the load on the suspension line can increase very quickly. In this situation, the line load may reach the capacity of the climber before it automatically cuts out.

4.3.5 Suspension Line Load with Manual Climbers

SWPSs and boatswain's chairs with manual climbers do not move nearly as quickly as powered climbers so there is less need to consider the capacity of the climber as the maximum possible suspension line load. A manual climber should be equipped with a limiter such as shear pins that resist overloading. Follow the manufacturer's instructions and the employer's work plan.

We recommend the following criteria for establishing these loads on manually powered systems.

Two-point SWPS: Calculate the weight of people, tools, and material expected to be on or suspended from the platform plus the weight of the platform, suspension lines, and climbers. Consider this load to be at least 1,000 lb. Then take 1,000 lb. or the total weight of the SWPS—whichever is greater—as the suspension line load for calculation purposes. Consider this the load on each suspension line.

For example, if the platform weighs 200 lb, two workers weigh 400 lb, and climbers and other gear weigh 200 lb, the total load is 800 lb. In this case, we recommend that each suspension line be rigged for 1,000 lb of line load. If the load had been 1,200 lb, we would recommend rigging for a suspension line load of 1,200 lb.

Note: You must check with the supplier to ensure that the equipment is capable of taking such a load.

Boatswain's Chair: Calculate the weight of the person, tools, materials, chair, suspension line and climber, but not less than 350 lb. The greater value then becomes the suspension line load for calculation purposes.

4.3.6 Calculation of Counterweight Load

As mentioned in section 4.3.3, if the instructions from the manufacturer for using counterweights are missing or illegible, do not attempt to calculate the number of counterweights needed. However, for manufacturers or suppliers who may need to do these calculations, the following information on calculating counterweights is provided.

The first operation in calculating the proper counterweight load is determining the appropriate suspension line load (LL) as discussed in 4.3.4 and 4.3.5. Because of dynamic loads and the unforgiving nature of the equipment, we need to build in a safety factor of 4. A sample formula is shown in Figure 23-29.

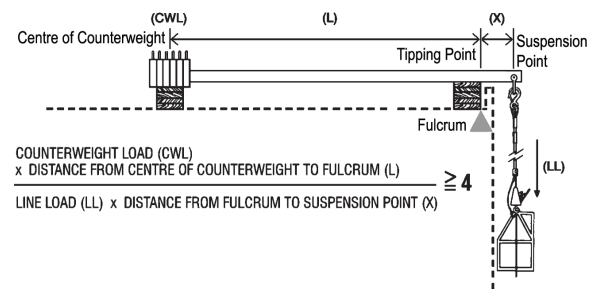

Figure 23-29: Calculating Counterweight Loads Example 1

We can also look at the problem in terms of what we have "working against us" versus what we need "working for us." What we have working against us are the suspension line load (LL) and its distance from what we call the "fulcrum" or the tipping point (DX). What we have working for us are the counterweight load (CWL) and the distance from the tipping point to the centre of the weights (DL). We need 4 times as much working for us as we have working against us (Figure 23-30).

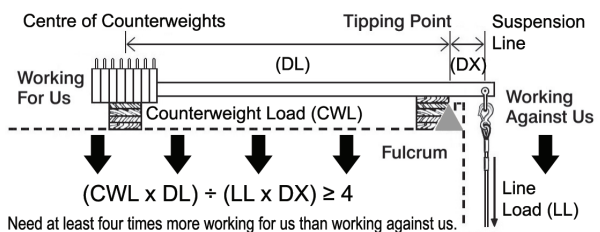

Figure 23-30: Calculating Counterweight Loads Example 2

If we assume our line load is 1,000 lb and the suspension point is located 1 foot beyond the outrigger beam's tipping point, then the tipping force (moment) is:

$$1,000 \text{ lb} \times 1 \text{ ft} = 1,000 \text{ lb-ft}$$

To resist this tipping force of 1,000 lb-ft and at the same time ensure a built-in safety factor of 4, we need to have 4 times this value working for us:

$$4 \times 1,000 \text{ lb-ft} = 4,000 \text{ lb-ft}$$

If overall beam length is 12 feet, then the section working for us to resist tipping force extends from the tipping point to the far end:

$$12 \text{ ft} - 1 \text{ ft} = 11 \text{ ft}$$

However, in our calculation we can only consider the distance from the fulcrum or tipping point to the centre of the counterweights.

Let's assume that there are 400 lb of 50-lb counterweights each 1/2 foot in width. In the figure below, you can see that the lever arm from the fulcrum to the centre of the counterweights can only be:

$$11 \text{ ft} - 2 \text{ ft} = 9 \text{ ft}$$

What we have working for us is:

$$400 \text{ lb} \times 9 \text{ ft} = 3,600 \text{ lb-ft}$$

This is less than the 4,000 lb-ft we require (see figure below).

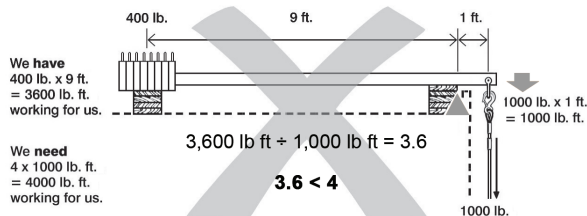

We will have to change something. We cannot change the suspension line load but we can change some of the other conditions. If we reduce the distance that the suspension point extends out from the tipping point to 9 in (0.75 ft), the value of what we have working against us is:

$$1,000 \text{ lb} \times 0.75 \text{ ft} = 750 \text{ lb-ft}$$

What we now need working for us is:

$$4 \times 750 \text{ lb-ft} = 3,000 \text{ lb-ft}$$

If we keep the same number of counterweights, the lever arm working for us becomes 9.25 ft long. It gained 3 inches (0.25 foot) when the other side was reduced 3 inches. We now have:

$$400 \text{ lb} \times 9.25 \text{ ft} = 3,700 \text{ lb-ft}$$

This would be satisfactory since 3,700 lb-ft is more than the 3,000 lb-ft that we actually need (see figure below).

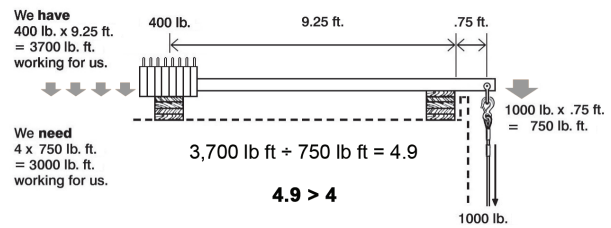

Remember—the line load must remain vertical. This affects whether or not the beam projection can be reduced and by how much. If the line load is not vertical, consult a professional engineer.

Another approach is to add more counterweights. If we add two more, our counterweights total 500 lb. However, our lever arm is reduced by 6 inches since the centre of the counterweights has shifted. What we have working against us is still the same:

$$1,000 \text{ lb} \times 1 \text{ ft} = 1,000 \text{ lb-ft}$$

What we need working for us is still:

$$4 \times 1,000 \text{ lb-ft} = 4,000 \text{ lb-ft}$$

What we have working for us is:

$$500 \text{ lb} \times 8.5 \text{ ft} = 4,250 \text{ lb-ft}$$

Again, this would be satisfactory since we have more working for us than we actually need (see figure below).

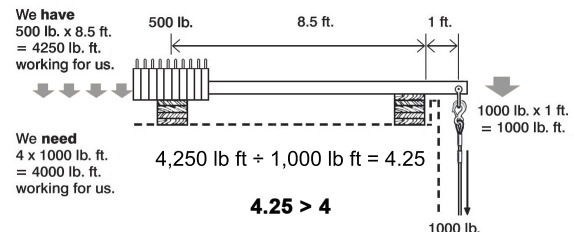

Before deciding whether or not to add more counterweights, keep in mind that every manufactured steel outrigger beam has a defined limit to the number of counterweights that can be placed and secured on it. This limit must be indicated on the beam label.

4.3.7 Counterweights

Counterweights vary in size and design based on the manufacturer. This is the main reason why one manufacturer's tables for counterweights cannot be used with another manufacturer's equipment.

Counterweights should be securely attached to the outrigger beam so that the vibration or movement of the beam will not dislodge or move them.

4.3.8 Roof Loads

Counterweights can overload roofs of light material such as metal roof deck. Most roofs are designed for the weight of the roof plus the design snow load, which may range between 45 and 80 lb per ft² for areas in Ontario.

Loads exerted by counterweights can be much greater than this and should be spread over a larger area by using plywood or planks (Figure 23-31). This also helps to reduce damage to built-up bituminous roofing.

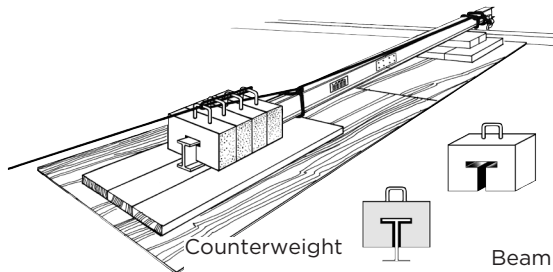

Figure 23-31: Planks and Plywood to Spread Counterweight Load

4.3.9 Parapet Walls

Parapet walls often present an obstruction to outrigger beams that must be overcome by the use of scaffolding or a special support structure (Figures 23-32 and 23-33).

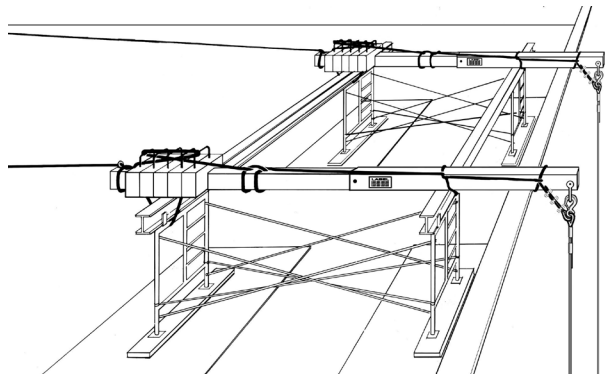

Figure 23-32: Scaffolding Used to Clear Parapet Wall

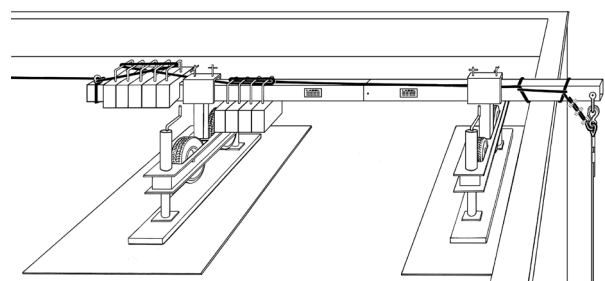

Figure 23-33: Special Support Structure Used to Clear Parapet Wall

Note: The fulcrum is the point supported by the scaffold or support structure—not the edge of the roof.

It is especially important to spread the loads on scaffold legs or the special support structure over a large area of the roof. Otherwise damage to the roofing material and possibly the deck itself may occur. Note planks and plywood under scaffold legs in Figure 23-32.

A scaffold system, or other specialized manufactured support system used to raise outrigger beams above the level of the parapet wall, must be designed by a professional engineer. A copy of the design drawings must be used to erect and inspect the system according to the engineer's design and must be kept on site as long as the system is in place.

4.3.10 Outrigger Beams

Outrigger beams should be placed at right angles to the edge of the roof wherever possible (Figure 23-34).

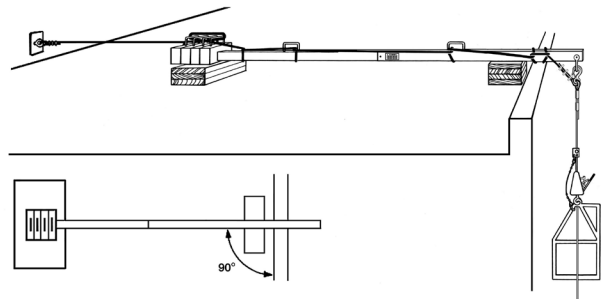

Figure 23-34: Outrigger Beams at Right Angles to Roof Edge

If it's not possible to set up outrigger beams at right angles to the edge, the beams must be adequately secured or braced to resist any lateral movement while the system is in use.

Suspension points on the beams must be the same distance apart as stirrups on the stage. Position the beams to ensure that spacing is the same. Failure to do so has resulted in many serious accidents.

Figure 23-35 illustrates what happens when the proper distance between outrigger beams is not maintained. The difficulty becomes serious as the stage nears the roof. At this point, sideways forces can move the outrigger beam, often causing a serious accident.

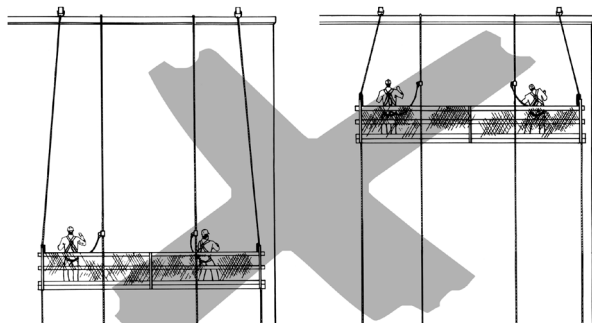

Figure 23-35: Improper Spacing of Outrigger Beams

The pins on sectional outrigger beams must be properly installed and secured (Figure 23-20 in section 4.2.3). Wiring the pin in position or securing the nut on the pin with a cotter pin is also important. If the pin is not secured, vibration can easily dislodge it and make the beam come apart.

This is especially important where manual climbers are used because the uneven jacking action of the climbers can apply intermittent loads to the beam and easily shake out a loose pin. This requirement also applies to shackle pins and eyebolts used on outrigger beam systems.

4.3.11 Tiebacks

Tiebacks should extend from the thimble of the suspension line back along the outrigger beam, with at least one half-hitch tied around the beam in front of the building facade, one half-hitch through the handles on each section (if they are so equipped), and one half-hitch in front of the counterweights. Tiebacks should then loop around the counterweight handles and then extend on back to an adequate anchorage (Figure 23-36).

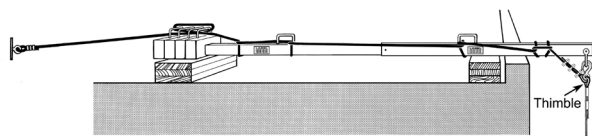

Figure 23-36: Tieback Rigging on Outrigger Beam

Installation can vary between manufacturers. Always use the equipment according to the manufacturer's instructions and the design drawings from the professional engineer.

Wire ropes are recommended for tiebacks with all suspended access systems. Rope tiebacks must meet the requirements of the site-specific work plan. As per CAN/CSA Z271-10 (s. 9.15.1), tiebacks must have the same rated strength as the primary suspension line.

Wire rope used for tiebacks should be at least equal in size to the wire rope used for the climber. After wire rope has been used for tiebacks it should not be used for suspension line because of damage and deformation from cable clips, bends, and hitches.

Wire ropes should be fastened with clips in the correct manner and recommended number (Table 23-1). Polypropylene rope should have either a spliced loop and thimble with a safety hook or shackle or be tied using a round turn and half-hitches or a triple bowline knot (see Figure 23-5).

Knots may reduce the safe working load of the ropes depending on the means of securing and are therefore a less desirable alternative. Protect rope from sharp bends. Figure 23-37 shows one method.

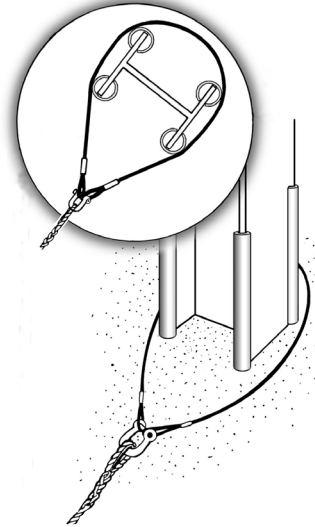

Figure 23-37: Use PVC/ABS Tubes to Protect Wire Rope

Where scaffolds are used for support structures, the tieback line should also be looped around the top of the scaffold (see Figure 23-32).

4.3.12 Anchorage for Tiebacks

Adequate anchorage for tiebacks may include the following fixed supports if they are capable of withstanding all loads and forces they will be subjected to, and sufficient to protect a worker's health and safety. A roof plan or design drawing approved by a professional engineer must be provided.

- The base of large HVAC units
- Columns on intermediate building floors or stub columns on roofs
- Designed tieback systems such as eye bolts and rings
- Large pipe anchorage systems (12-inch diameter or greater)
- Roof structures such as mechanical rooms
- Davit arms/systems
- Parapet clamps attached to reinforced concrete parapet walls **on the other side of the building.**

Never anchor tiebacks to:

- roof vents
- roof hatches
- small pipes and ducts
- metal chimneys
- TV antennas
- stair or balcony railings
- fixed-access ladders.

4.3.13 Parapet Clamps

Where parapet walls are constructed of **reinforced** concrete or **reinforced** masonry, parapet clamps may be used (Figure 23-38). Before using any type of parapet clamp, refer to the roof plans and design drawings to confirm that the parapet has been constructed with sufficient strength and performance characteristics to support the intended clamp.

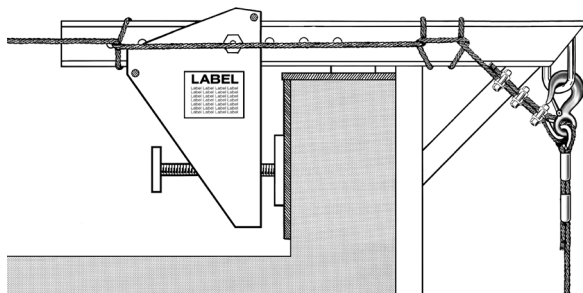

Figure 23-38: Parapet Clamp

Clamps must always be installed according to the manufacturer's drawings and written instructions. Ensure that clamps are securely fastened to the parapet wall and tied back to an adequate anchorage in a manner similar to tiebacks for standard outrigger beams.