

CHAPTER 6

GUIDELINES ON DESIGN OF

ELECTRICAL INSTALLATION

CHAPTER 6

GUIDELINES ON DESIGN OF ELECTRICAL INSTALLATION

6.1 Introduction

1. An assessment shall be made of any characteristics of equipment likely to have harmful effects upon other electrical equipment or other services, or be harmfully affected by them, or likely to impair the supply.
2. It is the responsibility of the customer's REC/REW to ensure that design of the electrical installation complies with HK Electric's Supply Rules, the Electricity (Wiring) Regulations and other relevant Government Ordinances and Regulations.
3. In accordance with the Code of Practice for the Electricity (Wiring) Regulations Code 18B, any person who wishes to have his electricity supply increased over and above the approved loading, or extended beyond the premises to which the supply is originally intended, should obtain prior approval from the electricity supplier concerned before any alteration or addition is carried out.
4. In accordance with the Code of Practice for the Electricity (Wiring) Regulations Code 18A(c), in the case of an alteration or addition to an installation which is connected to rising mains, the owner of the installation should, before commencing any alteration or addition, obtain agreement from the owner of the rising mains by completing form "Confirmation of Agreement from Owner of Rising Mains for Connection of Electrical Installation with an Increased Current Demand" (C.I. 140) provided by Electricity Supplier if the new current demand of the installation after the alteration or the addition will exceed the existing approved loading before the alteration or addition is carried out on the installation.
5. For installations taking supply directly from HK Electric supply point, a standard enquiry and reply form (C.I. 141) shall be used for enquiry of approved loading of the installation.
6. Under normal circumstances HK Electric will not comment on the customer's design during the planning stage but will inspect the installation before connection of supply.
7. We would try to highlight some interface areas where special attention from the designers are required. Drawings are also provided to illustrate the requirements.

6.2 Interconnection Facilities of Customer's Installation

1. Between HK Electric 11-kV/22-kV Line Switch Cum Metering Unit and Customer's 11-kV/22-kV Main Switch

- a. For 11-kV supply, the 11-kV cables between HK Electric 11-kV line switch cum metering unit and customer's 11-kV main switch shall be provided and installed by REC/REW. The 11-kV cables shall be of single-core construction, conductor of either compacted aluminum or compacted copper, circular in shape with 185-mm² cross-sectional area, XLPE insulated, with semi-conducting conductor screen and semi-conducting insulation screen, copper wire screen and MDPE or PVC outer sheath to IEC60502. The insulated core outer diameter of the cable should be within 27.8 mm to 31.5 mm and the outer diameter of the cable should not exceed 45 mm. The 11-kV cables shall be suitable for heat shrinkable 1-core termination or plug-in type termination of outer cone design. The customer shall provide cross-sectional diagram with detailed dimensions of the cable for HK Electric reference and approval.

The REC/REW may use alternative types of 11-kV cables, but he should first check with our Distribution Planning Department to see if the cables will be suitable for termination onto HK Electric 11-kV line switch cum metering unit by using heat shrinkable 1-core termination or plug-in type termination.

- b. For 22-kV supply, the 22-kV cables between HK Electric 22-kV line switch cum metering unit and customer's 22-kV main switch shall be provided and installed by REC/REW. The 22-kV cables shall be of single-core construction, conductor of either compacted aluminum or compacted copper, circular in shape with 185-mm² cross-sectional area, XLPE insulated, with semi-conducting conductor screen and semi-conducting insulation screen, copper wire screen and MDPE or PVC outer sheath to IEC60502. The insulated core outer diameter of the cable should be within 27.8 mm to 31.5 mm and the outer diameter of the cable should not exceed 45 mm. The 22-kV cables shall be suitable for plug-in type termination of outer cone design. The customer shall provide cross sectional diagram with detailed dimensions of the cable for HK Electric reference and approval.

The REC/REW may use alternative types of 22-kV cables, but he should first check with our Distribution Planning Department to see if the cables will be suitable for termination onto HK Electric 22-kV line switch cum metering unit by using plug-in type termination.

- c. Double-point earth bonding will be applied onto the section of cables from HK Electric 11-kV/22-kV line switch cum metering unit to customer's main incoming 11-kV/22-kV switch. Customer's REC/REW shall earth the metallic screen or armouring at their side.
 - d. HK Electric will provide the necessary materials and labour to terminate the cables at HK Electric 11-kV/22-kV line switch cum metering unit and the customer shall allow an extra length of 1.5 m of the 1-core 11-kV/22-kV cables measuring from the bottom of HK Electric 11-kV/22-kV line switch cum metering unit for HK Electric to prepare the termination.
 - e. The termination of customer's 11-kV/22-kV cables onto HK Electric 11-kV/22-kV line switch cum metering unit will be performed by HK Electric on behalf of the customer and a service charge will be chargeable to the customer. The cable termination and its associated accessories will become the property of the customer.
 - f. The termination of 11-kV/22-kV cables onto customer's 11-kV/22-kV main incoming switchgear shall be the responsibility of REC/REW.
2. HV Customer Supplied via One 11-kV/22-kV Supply Point

Where a building is supplied via one 11-kV/22-kV supply point only, the customer is recommended applying for one more supply point in order to facilitate the maintenance of customer's installation or restoration of supply in case of contingency.

3. HV Customer Supplied via More Than One 11-kV/22-kV Supply Point
- a. Where a building is supplied via more than one 11-kV/22-kV supply point, the customer is recommended installing interconnection(s) among the 11-kV/22-kV supply points for better security of electricity supply. All incoming and interconnection switchgear/circuit breakers shall be of 3-pole type interrupting all live conductors which shall be mechanically and electrically interlocked to prevent HK Electric 11-kV/22-kV sources from operating in parallel. Castell Key interlock can be considered as a kind of mechanical interlock.

- b. Where an LV interconnection between different 11-kV/22-kV supply points is provided for customer's installation, the customer shall design and install the LV interconnection in such a way so as to avoid undesirable fluctuation of 11-kV/22-kV load and/or undesirable transfer of load among the 11-kV/22-kV supply points.
- c. To prevent sudden transfer of large block load among the 11-kV/22-kV supply points, which could overload HK Electric network and result in further loss of supply, locking facilities on the customer's switches which are interconnecting different 11-kV/22-kV supply points are required. These locking facilities should only be operated by HK Electric authorised persons including in the event of contingency.

In general, customer should arrange padlocks at the electrical control switch and the manual operating switch of the customer's 11-kV/22-kV interconnection switches.

The customer should provide and install key boxes, one for each interconnection switch. The key boxes should be installed at a conspicuous location inside the customer's switchroom as close to the respective interconnection switches as possible but in general should not be farther than 3 m from the respective interconnection switches. The layout plan of the key boxes should be submitted for HK Electric's prior approval.

The keys of padlocks which are applied on the interconnection switches should be kept inside the key boxes respectively. HK Electric standard locks will be applied to the key boxes. The customer should arrange bilingual labels at the concerned 11-kV/22-kV interconnection switches and on the wall above the key boxes to remind the customer's operational staff the requirement to approach HK Electric to unlock the 11-kV/22-kV interconnection switches before load transfer. Details of the labels and the key boxes are shown in Drg. Nos. GCS/6/01 and GCS/6/02 respectively.

- d. To avoid overloading HK Electric's 11-kV/22-kV network, in case of contingency or during maintenance of customer's installation, HK Electric may only allow part of the load to be transferred among the 11-kV/22-kV supply points at certain time slot to be agreed with the customer. The customer should contact the Customers Emergency Services Centre in case of contingency, or the Customer Installation Section at least 2 weeks before the planned maintenance date for the necessary arrangements.

4. Between HK Electric Transformers

- a. Installation shall be directly connected to HK Electric transformers via transit blocks or single core cables. The examples of cable sizes for the cables connecting between HK Electric transformers and customer's main switch are shown in Drg. No. GCS/6/03.
- b. For supply directly obtained from two or more units of HK Electric transformers within the same substation, the incoming low voltage switchgears at the customer's main switchroom should be interconnected via bus-section switch(es) in order to maintain a high reliability of electricity supply to the customer. The arrangements shown on Drg. Nos. GCS/6/04, GCS/6/05 and GCS/6/06 are for REC/REW's reference. REC/REW shall provide a schematic diagram showing the proposed arrangement of their main incoming switchgear to Distribution Planning Department of HK Electric before the substation layout design could be finalized.
- c. All interconnecting devices including the bus-section switch shall be of 4-pole type with mechanical and electrical interlocks.
- d. Castell Key interlock can be considered as a kind of mechanical interlock.

5. Between HK Electric Supply and Customer's Generator

- a. Changeover device used for interconnection between the normal and standby sources shall be of 4-pole type with mechanical and electrical interlocks.
- b. Local isolation switch shall be installed after the changeover device.

6. Between LV Service Cables

Interconnection facilities between LV service cables will not be allowed.

6.3 Customer's 11-kV/22-kV Main Switch

The 11-kV/22-kV main switch shall incorporate the following basic requirements:

1. The 11-kV main switch, i.e. the circuit breaker, used to receive supply directly from HK Electric's supply source, should be rated for use at 11 kV and with rated short time withstand current of 18.4 kA rms for 3 seconds. The lightning impulse withstand voltage should not be less than 75 kV peak.

Means of protection shall grade properly with HK Electric's infeed requirements as shown in Drg. Nos. GCS/4/01 and GCS/4/02.

2. The 22-kV main switch, i.e. the circuit breaker, used to receive supply directly from HK Electric's supply source, should be rated for use at 22 kV and with rated short time withstand current of 25 kA rms for 3 seconds. The lightning impulse withstand voltage should not be less than 125 kV peak.

Means of protection shall grade properly with HK Electric's infeed requirements as shown in Drg. Nos. GCS/4/03 and GCS/4/04.

3. The overcurrent setting of the main circuit breaker shall normally not exceed 200 A and should normally be of draw-out type and lockable at that position, rated for fault making and breaking, and shall have an earthing switch to earth the incoming cable. Fixed type circuit breaker in conjunction with an isolator which is mechanically interlocked with the circuit breaker may be used provided that there is clear indication between the service position and the isolated position and can be lockable at the isolated position.
4. Interlock facilities shall be provided between the circuit breaker, the earthing switch and the isolator.
5. Safety shutter shall be provided at the switchgear spouts.
6. The earthing switch at the main incomer shall be lockable at open and closed position and of fault making type. The earthing switch shall only be operated by mechanical means when it is closed to circuit earth position.

7. HK Electric will lock the earthing mechanism of the customer's 11-kV/22-kV incomers earth switch to maintain it in open position in order to avoid inadvertent closing of HK Electric 11-kV/22-kV supply to earth without the permission from HK Electric. The customer's 11-kV/22-kV incomers should provide necessary provisions to accept the application of either one of the HK Electric provided standard locks as shown in Drg. No. GCS/6/07 to lock the earthing mechanism in open position. The customer should arrange bilingual label(s) at the concerned customer's main switch(es). Details of the label are shown in Drg. No. GCS/6/08.

6.4 Nomenclature of Customer's 11-kV/22-kV Apparatus

1. Customer Main Switches

- a. The nomenclature of the customer main switches shall be numbered in consecutive ascending order in one direction and in the format of:

“####SNYYYYYY”

where **####** is customer defined 4-alpha-numeric character;
SNYYYYYY is the Supply Number assigned by HK Electric.

The customer switch destination shall be in the format of:

“TO : *ABC S/S SW XX SNYYYYYY*”

where ***ABC S/S*** is the HK Electric substation name;
SW XX is the remote HK Electric switchgear number;
SNYYYYYY is the Supply Number assigned by HK Electric.

- b. The REC/REW shall confirm that the agreed wordings are on the front panel of the corresponding switchgear.

2. Labelling of Customer Incomer

Under certain circumstances, the HV supply incoming cable could be terminated either to the front or rear spouts of the customer main switch. In order to identify the position of HV supply incoming cable connection, the following are recommended:-

- a. Bilingual label “Caution – HV supply incoming cable is connected to front (or rear) spouts” with Chinese translation “小心 – 高壓供電電纜接駁到前（或後）插座” shall be secured onto the switch panel to which the HV supply incoming cable is connected.

- b. Identification label “HV Supply Incoming Cable , 高壓供電電纜” shall be painted on the shutter of spouts to which the HV supply side cable is connected.

6.5 Customer's LV Main Switch

1. General

- a. A customer main switch shall be installed and connected immediately before HK Electric's meter.
- b. Means of protection shall grade properly with HK Electric's infeed as shown in Drg. No. GCS/4/05.
- c. A customer main switch or circuit breaker shall be provided for every customer's installation which shall interrupt all live conductors of the installation. The main switch or circuit breaker shall be readily accessible to the customer and shall incorporate:-
 - i. means of isolation and switching,
 - ii. means of protection against overcurrent, and
 - iii. means of protection against earth leakage.

For a 3-phase 4-wire supply, a linked switch or linked circuit breaker may be arranged to disconnect the phase conductors only and in such case, a link shall be inserted in the neutral conductor and securely fixed by bolts or screws.

For a single-phase supply, the main switch shall be of double-pole type interrupting both live and neutral conductors.

- d. The means of isolation and switching shall be:-
 - i. a device selected and installed in such a way as to prevent unintentional reclosure,
 - ii. capable of cutting off the full load current of the whole installation from supply,
 - iii. provided with clearly and reliably indicated ON & OFF position.

- e. The means of protection against overcurrent shall be a device capable of breaking (and for circuit breakers, making) any overcurrent up to and including the prospective short circuit current at the point where the device is installed. Such device may be circuit breaker incorporating overload release, or fuse, or circuit breaker in conjunction with fuses.

Where supply is taken directly from HK Electric transformer or underground cable, the main switch or circuit breaker shall have a short-circuit breaking capacity of 40 kA symmetrical at low voltage.

- f. The means of protection against earth leakage shall be by earthed equipotential bonding and automatic disconnection of supply. The characteristics of the protective device for automatic disconnection and the earth fault loop impedance at the main switch shall be co-ordinated so that disconnection is achieved within 5 seconds during an earth fault.
- g. A circuit breaker used to receive supply from HK Electric transformer shall normally be of draw-out type. An isolator may be used in conjunction with fixed type circuit breaker provided that it is mechanically interlocked with the circuit breaker.
- h. Where the supply is designed to be taken from more than one transformer, interconnection facilities between main incoming circuit breakers are recommended and should be arranged in accordance with HK Electric's requirements. All incoming and interconnection circuit breakers shall be of 4-pole type interrupting all live conductors (i.e. phase and neutral) and mechanically and electrically interlocked to prevent HK Electric transformers from operating in parallel.

Where a standby generator is installed, a mechanically and electrically interlocked 4-pole changeover device shall be used for interconnection between the normal and standby sources to ensure that neutral unbalance and fault currents return to the correct source of supply.

- i. Where a customer's installation is supplied from an overhead line system, the installation shall be protected against earth leakage by RCD.

2. Building Main Switch

A main switch shall be installed to control all the outgoing installations in a building supplied from the same incoming supply.

3. Main Switch for Communal Installation

A main switch shall be installed to control the communal installation of the building.

6.6 Changeover Arrangement for Fire Services Installation Supplied from the Same Source

1. 4-pole changeover device should be installed. Infeed circuits and outgoing circuits may be of triple-pole and neutral arrangement.

2. Local isolation switch should be installed after the changeover device.

6.7 Rising Mains Installation

1. Any building of more than four floors including the ground floor and designed for occupation of more than one customer shall be provided with 3-phase 4-wire electrical rising mains with 3-phase and neutral tee off at each floor unless otherwise agreed by HK Electric.

2. Each rising mains installation shall be protected against overcurrent and earth leakage and shall be equipped with suitable means of isolation.

3. In premises intended for multiple occupations, separate riser earthing conductors shall be provided to earth all the units. The minimum cross-sectional area of riser earthing conductor shall be 70 sq. mm for copper and 150 sq. mm for aluminum.

4. Size of rising mains shall match with the current rating of the corresponding riser switch at the origin of the circuit and shall be reasonably designed to cater for the demand. Where the riser switch is located outside the building served, a local riser switch shall be provided.

5. Instantaneous type RCD shall not be used as multi-customer riser switch.

6. Size of neutral conductor of 3-phase 4-wire rising mains shall not be less than that of the phase conductor unless otherwise agreed.

6.8 Electrical Design for Residential Flats

1. The following recommendations are prepared to assist developers, architects, E&M consultants and contractors in assessing the electricity demand of residential flats so that adequate provision of electricity supply can be made to meet the need of modern homes.
2. Electricity supply to residential flats is arranged in either single-phase or three-phase. An installation of which the approved loading is less than 60 A should normally be arranged to receive single-phase supply. An installation requiring more than 60 A should be designed to receive 3-phase supply.
3. In the light of the rise in standard of living in the recent years, the aspiration to improve the quality of living homes in our community is getting higher. Nowadays, a much wider range of electrical appliances are available in the market than before, and many of these appliances such as electric water heaters, kitchen apparatus, etc., are increasingly popular in modern households. Therefore, it is a good design practice to ensure that adequate capacity of electricity supply is provided for modern residential flats so that the occupants may avail themselves of the modern range of electrical appliances to enjoy quality living standard. In addition, good design not only increases the value and the status of the property but also avoids unnecessary and tedious modification/reinforcement work afterwards, which is often costly and time consuming.
4. Taking into consideration the range of electrical appliances commonly used nowadays in modern households, it is reckoned that the total load could easily exceed 60 A single phase for residential flat of 70 sq. m or above. In view of the above, we recommend developers, architects, E&M consultants and contractors adopt 3-phase electricity supply for residential flats of gross floor area of 70 sq. m or above.
5. When an installation is designed to receive 3-phase supply, the phase connection of different types of appliances (e.g. air conditioners, water heaters, cooker switches and socket outlets etc.) should be evenly spread among the three phases such that the electricity demand from a particular type of appliance between adjacent flats on the same floor or within the building will not be concentrated at one particular phase at a certain time of the day, such as TV peak hours or meal preparation hours.
6. Apart from ensuring an adequate capacity of electricity supply, the design for the residential flats to receive 3-phase supply also has the following advantages:-

- a. It minimizes unbalanced load condition and overloaded condition of the communal installations, such as lateral mains and/or rising mains due to unbalanced connection and/or unbalanced load patterns that could often occur with single-phase installations. This is because load balancing can be more easily achieved with three-phase installations in the design and construction stage. Even in the exceptional circumstances when subsequent load balancing work is required, the work will be much simpler with 3-phase installations.
 - b. It reduces energy loss in the neutral conductors when compared with single-phase installations.
 - c. It enables the occupants to use three-phase electrical appliances at home.
7. These recommendations are for general reference only. They shall not circumvent or precede any requirements in relevant Ordinance, the Electricity (Wiring) Regulations, or HK Electric's Supply Rules. The responsibility of design of an electrical installation shall still solely rest with the designer.

6.9 Electrical Design for Restaurants

1. The following recommendations are to assist developers, architects, E&M consultants and contractors to assess the demand of restaurants applying for the provision of electricity.
2. Today, there is a wide range of electric kitchen equipment available on the market, and many are increasingly popular with industry practitioners. It is, therefore, a good design practice to ensure that there is an adequate supply of electricity provided for restaurants wishing to enjoy the wide range of electric kitchen equipment and an improved environment. Besides, having a good design not only increases the value and status of the restaurant, but also avoids unnecessary and tedious modification/reinforcement works later as these are often costly and time-consuming.
3. When considering the range of electric kitchen equipment commonly used and the usable floor area of such restaurants, we recommend the following main switch rating requirements:

(FOR REFERENCE ONLY)

Table for Main Switch Current Rating of Fully Electric Restaurant

Floor Area Range (Usable Floor Area)		*Main Switch Rating (A), 3 phases		
m ²	ft ²	Chinese Restaurant	Fast Food Shop	Asian Cuisine/ Western Restaurant/ HK Style Cafe
185.8 or below	2,000 or below	300	150	200
185.9 to 232.3	2,001 to 2,500	400	250	250
232.4 to 278.7	2,501 to 3,000	500	300	300
278.8 to 325.2	3,001 to 3,500	500	400	400
325.3 to 371.6	3,501 to 4,000	600	500	500
371.7 to 464.5	4,001 to 5,000	800	600	600
464.6 to 557.4	5,001 to 6,000	800	Please contact 2843 3669 for enquiry	
557.5 to 743.2	6,001 to 8,000	1000		
743.3 to 929.0	8,001 to 10,000	1250		
Above 929.0	Above 10,000			

* Remarks:

- (i) The electrical demands for different floor areas listed above are by no means exhaustive.
- (ii) Electrical demand can also vary according to the different equipment or electrical appliances used, and whether air conditioning is provided by a centralized system within the building.

4. For additional information on commercial kitchen equipment, please contact our Hotline at 2843 3669.
5. These recommendations are for general reference only. They shall not circumvent or precede any requirements in relevant Ordinance, the Electricity (Wiring) Regulations, or HK Electric's Supply Rules. The responsibility of design in an electrical installation shall still solely rest with the designer.

6.10 Earthing

1. The customer is required to provide his own effective earthing system, including a connection to earth electrodes, for its protection against earth fault currents and dangerous earth leakage currents.
2. The sheath of 11-kV/22-kV incoming cables shall be bonded to earth at customer side as well as HK Electric side.

3. If the customer main earthing system is bonded to HK Electric main earthing system, an insulated disconnection link as shown on Drg. No. GCS/6/09 is recommended for the provision of disconnection of the bonding conductor.

6.11 Limit on Length of Customer's Interconnecting Installation

The following limits shall be strictly adhered to in designing the interconnecting equipment between HK Electric supply point/position and the customer main switch:-

HK Electric Supply Position	Interconnecting Equipment (by Customer)	Limits on Length of Customer's Interconnecting Installation
1. 22-kV Line Switch Cum Metering Unit	Cable	20 m
2. 11-kV Line Switch Cum Metering Unit	Cable	20 m
3. LV Busbar	Transit Block & Busbar/Cable	10 m
4. LV Isolator	Cable	20 m
5. LV Service Cutout	Cable	3 m

6.12 Electromagnetic Interference in Substations

The magnetic field generated from the current in busbars or single core cables in substations would cause electromagnetic interference, which may be of concern to tenants, occupants and/or users of the immediate vicinity. In view of this, we recommend the architects and E&M consultants implement the following arrangements in their design to minimize the interference caused by the magnetic field generated from the proposed substations:-

1. Architects and E&M consultants should arrange all the substation walls, ceiling and floor to be screened off by metallic sheet at construction stage.
2. Architects and E&M consultants should incorporate in the design of an increased headroom at the floor where the proposed substation is situated so as to reduce the interference to the floor above. Similarly, the headroom of the floor just below the substation should be increased.

3. Architects and E&M consultants should inform the tenants, occupants and/or users at the floors just above and below the substations of the possibility of electromagnetic interference right at the first occupation.
4. Since the magnetic field generated by the customer's high current carrying conductors, e.g. the rising mains from the switchroom, will also cause electromagnetic interference, architects and E&M consultants are advised to check at the design stage if there is any area that would be affected by the customer's installations and carry out the necessary precautionary arrangements accordingly. Suggestions for design and installation of LV single-core cables to minimize electromagnetic interference is shown on Drg. No. GCS/6/10.

6.13 Sequence of Inspections for Multi-Customer Installations

In a multi-customer building, there are many cases that certain installations must be in order before inspection of the other installations. In general, the sequence of inspections shall be communal supply, tenant risers and then individual customer installations. Typical examples on these cases, the correct sequence and scope of inspections are shown on Drg. Nos. GCS/5/04 to GCS/5/13. The customer may contact our Customer Installation Section, on 9th Floor, Electric Centre, 28 City Garden Road, North Point, Hong Kong or by calling 2887 3455 for further assistance.

6.14 Supply Arrangements for Residential and Commercial Loads in a Building

From time to time, in a complex building comprising both residential and commercial customers, there are often difficulties for the residential and commercial customers to reach a mutual agreement on the electricity shutdown schedule to carry out electrical maintenance works. To facilitate the future maintenance work of the customer's installation for a residential-cum-commercial building, it is highly recommended that the electrical consultant / designer should separate the electrical installations of the residential and commercial loads as shown in Drg. No. GCS/6/19. The two installations will be fed by different HK Electric sources. By doing this, the residential and commercial loads can be shut down independently of each other for the convenience of each category of customers. Our engineers will be pleased to discuss with you and offer further assistance in this respect. Please contact us in the early design stage so that this arrangement can be duly incorporated.

6.15 Separation of Lighting Supplies for Department Store / Shopping Mall

Interior lighting is essential to the operation of a department store / shopping mall and a complete loss of lighting supply may seriously affect business operation as well as movement of the people inside. Thus where a department store / shopping mall is supplied by more than one HK Electric supply source, the electrical consultant / designer is strongly recommended to spread the lighting supplies across the different HK Electric supply sources to achieve better security of supply to the lighting.

6.16 Phase Identification

1. Requirements for Meter Leads and Tails with New Cable Colour Code

a. Single-phase Meter

Where new colour coded cable is used in meter leads and/or tails, both meter leads and tails shall be fitted with proper, durable and legible phase identification labels (such as cable ties, sleeves, ferrules etc.) marked in L1 or L2 or L3 and N.

Where new and old colour coded cables are used separately in meter leads and tails, a yellow warning notice in both English and Chinese shall be displayed at or close to the nearest upstream main switch/point of isolation. Details of the label shall comply with the Code of Practice for the Electricity (Wiring) Regulations.

b. Three-phase Meter

Where new colour coded cable is used in meter leads and tails, it is recommended that both meter leads and tails shall be fitted with proper, durable and legible phase identification labels (such as cable ties, sleeves, ferrules etc.) marked in L1, L2, L3 and N.

Where different colour coded cables are used in meter leads and tails, both the new and old colour coded cables shall be fitted with proper, durable and legible phase identification labels (such as cable ties, sleeves, ferrules etc.) marked in L1, L2, L3 and N. A yellow warning notice in both English and Chinese shall be displayed at or close to the nearest upstream main switch/point of isolation. Details of the label shall comply with the Code of Practice for the Electricity (Wiring) Regulations.

2. New Cable Colour Code Arrangement on Transit Block

Phase identification labels L1 L2 L3 N E and E N L3 L2 L1 shall be provided in appropriate position of the transit block. Details of the labels are shown in Drg. No. GCS/3/14.

3. New Cable Colour Code Arrangement for Single-Core Cables Connected to HK Electric Substation

Phase identification labels L1, L2, L3 and N shall be provided at the cable ends terminated to HK Electric substation. Details of the labels shall be in accordance with Item 9 of the Notes for Drg. No. GCS/3/15.

4. New Cable Colour Code Arrangement for Single-Core Cables Connected to HK Electric Service Cutout

The cable ends terminated onto HK Electric three-phase service cutout shall be fitted with proper, durable and legible phase identification labels (such as cable ties, sleeves, ferrules etc.) marked in L1, L2, L3 and N.

The cable ends terminated onto HK Electric single-phase service cutout shall be fitted with proper, durable and legible phase identification labels (such as cable ties, sleeves, ferrules etc.) marked in L and N.

6.17 Check List for Customer's Schematic Wiring Diagram

1. The installation shall comply with HK Electric's Supply Rules and the relevant Government Ordinances.
2. Harmonic distortions generated from non-linear loads may affect HK Electric's system and/or the electricity supply to other customers. Harmonic distortions shall not exceed the limits as stipulated in our Supply Rules.
3. Undervoltage protective devices should not be installed at main switches or switches affecting supply to more than one customer and/or equipment. Whenever undervoltage protective devices are to be used, they should be installed at the load side only, in order to avoid unnecessary tripping to other equipment.

4. The magnetic field generated by customer's high current carrying conductors/cables will cause electromagnetic interference. Architects and E&M consultants are advised to check at the design stage if any area would likely be affected by the magnetic field from the customer's installations and carry out necessary mitigation measures. To reduce the magnitude of magnetic field emanating from the LV single core cables, it is suggested that LV single core cables will be installed in the disposition and manner as shown in Drg. No. GCS/6/10.
5. For motor installation design, designers are advised to take into consideration the effect of transient voltage dips, which though infrequent, may occur occasionally because of system disturbance.
6. The length of customer LV cable between HK Electric service cutout and customer LV main switch shall not exceed 3 metres.
7. The length of busway/cable between transit block and customer main switch shall normally not exceed 10 metres.
8. The length of customer LV cable between HK Electric transformer/isolator and customer LV main switch shall not exceed 20 metres.
9. For customer LV cable between HK Electric transformer/isolator and customer LV main switch, a maximum of four cables per phase may be used. The neutral conductor shall be of same installed rating as the phase conductor.
10. The characteristics of the protective devices for automatic disconnection and the earth fault loop impedance at the LV main switch shall be co-ordinated so that disconnection is achieved within 5 seconds during an earth fault.
11. A main switch/building main switch shall be installed to control all outgoing installations connected to the same source of supply.
12. Switchgear/circuit breakers connected directly to HK Electric's transformer/service cutout shall have short-circuit breaking capacity of 40 kA at low voltage.
13. Circuit breaker used to receive supply directly from HK Electric's transformer shall normally be of draw-out type.

14. Where the supply is designed to be taken from more than one transformer, interconnection facilities between main incoming circuit breakers are recommended and shall be arranged in accordance with HK Electric's requirements. All incoming and interconnection circuit breakers shall be of 4-pole type interrupting all live conductors which shall be mechanically and electrically interlocked to prevent HK Electric's transformers from operating in parallel.
15. In accordance with Regulation 12(2) of the Electricity (Wiring) Regulations, where the supply is taken directly from HK Electric transformer within the premises in which the fixed electrical installation is situated, the main earthing terminal of the installation shall be bonded to the bonding terminal that connects to the earthed point of HK Electric transformer. A disconnection link (Drg. No. GCS/6/09) for testing purpose shall also be provided to disconnect the bonding conductor between HK Electric and customer's earthing system.
16. In accordance with Regulation 12(3) of the Electricity (Wiring) Regulations, where the supply is taken from HK Electric service cutout (LV RMU Type), the main earthing terminal of the installation shall be bonded to the bonding terminal that connects to the exposed conductive parts at the cable termination at the point of supply. A disconnection link (Drg. No. GCS/6/09) for testing purpose shall also be provided to disconnect the bonding conductor between HK Electric and customer's earthing system.
17. The customer LV cable between HK Electric service cutout and customer LV main switch shall be of single-core, circular and non-metallic sheathed type.
18. The minimum size of copper conductor to be terminated onto the outgoing service terminals of HK Electric service cutout is 50 sq. mm.
19. A maximum of two sets of customer's wiring could be connected directly to HK Electric service cutout.
20. For installation having a rated capacity exceeding 400 A in each phase of a 3-phase 4-wire system, the associated neutral conductor may have a cross-sectional area smaller than the cross-sectional area of the phase conductors if overcurrent detection is provided for the neutral conductor, which is appropriate to the cross-sectional area of the conductor. This detection shall cause the disconnection of the phase conductors but not necessarily the neutral conductor.

21. A main switch shall be installed to control all the communal installations of the same customer.
22. Communal installations of the same customer should be arranged to receive supply from one source.
23. Where standby generator is installed, mechanically and electrically interlocked 4-pole changeover device shall be used for interconnection between the normal and standby sources to ensure that neutral unbalance and fault current return to the correct source of supply.
24. Changeover device shall be of 4-pole type.
25. Local isolation switch shall be installed after the changeover device.
26. Local riser switch shall be installed for each multi-customer rising mains at each tower/block.
27. 3-phase 4-wire electrical rising mains with 3-phase 4-wire tee-off at each floor shall be installed.
28. For 3-phase electrical rising mains, tee-off or lateral mains at each floor shall be 3-phase 4-wire.
29. Proper labels displaying the Supply Number (SN) should be provided at the cutout/plug-in unit at each floor.
30. Loading on the three phases should be properly balanced in lateral mains and rising mains.
31. Proper lateral mains and meter board wiring shall be provided at meter rooms/ducts for future shop tenants in order to avoid future chaotic situation. Adequate space shall be provided in meter room/duct for main switches of future shop tenants.
32. Riser earthing conductor shall be installed.
33. The minimum cross-sectional area of riser earthing conductor shall be 70 sq. mm. for copper and 150 sq. mm. for aluminum.
34. Switchgear/circuit breakers shall have adequate short-circuit breaking capacity at the point of installation.
35. Rating of customer main incomer switch shall not exceed 2250 A.

36. Electrical installation inside a unit/flat in a multi-story building shall be considered as a single fixed electrical installation. Each shall have its own main bonding connection, and the warning notice “SAFETY EARTH CONNECTION - DO NOT REMOVE” and “安全接地終端 – 切勿移去” in legible letters and characters each not less than 5 mm high shall be permanently fixed at or near the point of connection of every earthing conductor to an earth electrode, and at or near each main bonding connection.
37. Customer main switch shall be installed at a position immediately before HK Electric's meter.
38. Single-phase customer main switch installed immediately before HK Electric's meter shall be of double-pole type interrupting both live and neutral conductors.
39. Customer main switch shall incorporate means of isolation/switching and protection against overcurrent and earth leakage.
40. Instantaneous type RCD shall not be used as multi-customer riser switch.
41. For 3-phase 4-wire supply, both 4-pole and TP&N switch may be used. If the switch is a 3-pole linked switch or circuit breaker, a link shall be inserted in the neutral conductor and securely fixed by bolts or screws.
42. An installation requiring more than 60 A should be arranged to receive 3-phase supply.
43. Appropriate rating factors shall be applied to determine the current carrying capacity of cables.
44. The current rating of a cable in a circuit shall match with the current rating of the corresponding protective device at the origin of the circuit.
45. When an installation is supplied by more than one HK Electric source, such as transformer/service cutout, one application form for each source should be provided.
46. A segregated, sealable and readily accessible C.T. Chamber shall be provided in all switch/switchboard to accommodate HK Electric metering equipment for supply greater than 100 A, 3-phase.

47. For new installations of C.T. operated meters with a main switch rating of 600 A or above, located inside the customer switchboard, a Cat. 5e cable shall be supplied and installed by the customer with mechanical protection from the meter to the Tariff Meter Communication (TMC) Termination Box in the customer switchroom. Each end of the mechanical protection shall be terminated with a junction box inside which there should be at least 1m spare length of the Cat. 5e cable. The junction boxes shall be within 0.5 m of the meter and the TMC Termination Box.
48. Metering point of an installation shall be at a position as close to the source of supply as practicable.
49. Metering point of an installation shall be arranged to avoid double metering or unmetered situation. For load transfer cases, REW shall check and confirm that there is no other meter installed before and after the present or proposed metering point.
50. Proper labels should be applied on spare switchgear on the customer switchboard, to identify if the corresponding circuit is metered or unmetered.
51. Check meters should not be installed for resale of electricity obtained from HK Electric.
52. For 3-phase installation with main switch rating greater than 100 A, C.T. operated meter will be installed.
53. For 3-phase installation with main switch rating of 100 A and below, direct-connected type meter will be installed.
54. For 3-phase installation with main switch rating of 100 A and below, 35 sq. mm, circular, multi-stranded, copper meter leads and meter tails shall be provided for termination onto HK Electric's direct-connected type meter.
55. For single-phase installation, not greater than 25 sq. mm, circular, multi-stranded, copper meter leads and meter tails shall be provided for termination onto HK Electric's direct-connected type meter.
56. For termination onto HK Electric's direct-connected meter, circular, multi-stranded copper conductors shall be used. Sector-shaped conductors are not allowed.

57. The size of meter leads and meter tails shall not be less than 4 sq. mm stranded copper conductors.
58. Meter position shall satisfy the requirement for meter reading, meter fixing and meter maintenance. It shall comply with the space requirements per Drg. No. GCS/5/14 and the general requirement for installation of tariff meter.
59. Permanent, tidy and securely fixed address label shall be provided for meter board, main switch and meter tails.
60. All metering cables shall be correctly and permanently color coded for phase identification.
61. Adequate lighting shall be provided at meter duct/room for meter reading/maintenance work.
62. Meter duct/room shall be properly labelled, easily accessible and be provided with locks. A master key exclusively for the use of all the meter duct/room locks shall be available at the Management Office to facilitate monthly meter reading. This master key shall not be able to open other locks.
63. The length of customer 11-kV/22-kV cables between HK Electric 11-kV/22-kV line switch cum metering unit and customer's 11-kV/22-kV main switch shall not exceed 20 metres.
64. To prevent sudden transfer of large block load among the 11-kV/22-kV supply points, which could overload HK Electric network and result in further loss of supply, locking facilities on the customer's switches which are interconnecting different 11-kV/22-kV supply points shall be required. For the details of the locking arrangement, please refer to Clause 6.3.2.c.
65. 11-kV/22-kV main switch shall comply with the following requirements:-
 - a. The 11-kV main switch, i.e. the circuit breaker, used to receive supply directly from HK Electric's supply source, should be rated for use at 11 kV and with rated short time withstand current of 18.4 kA rms for 3 seconds. The lightning impulse withstand voltage should not be less than 75 kV peak.

- b. The 22-kV main switch, i.e. the circuit breaker, used to receive supply direct from HK Electric's supply source, should be rated for use at 22 kV and with rated short time withstand current of 25 kA rms for 3 seconds. The lightning impulse withstand voltage should not be less than 125 kV peak.
 - c. The overcurrent setting of the main circuit breaker shall normally not exceed 200 A and should normally be of draw-out type and lockable at that position, rated for fault making and breaking, and shall have an earthing switch to earth the incoming cable. Fixed type circuit breaker in conjunction with an isolator which is mechanically interlocked with the circuit breaker may be used provided that there is clear indication between the service position and the isolated position and can be lockable at the isolated position.
 - d. Interlock facilities shall be provided between the circuit breaker, the earthing switch and the isolator.
 - e. Safety shutter shall be provided at the switchgear spouts.
 - f. The earthing switch at the main incomer shall be lockable at open and closed position and of fault making type. The earthing switch shall only be operated by mechanical means when it is closed to circuit earth position.
 - g. HK Electric will lock the earthing mechanism of the customer's 11-kV/22-kV incomers earth switch in order to avoid inadvertent closing of HK Electric 11-kV/22-kV supply to earth. For the details of the locking arrangement, please refer to Clause 6.3.7.
66. For 11-kV/22-kV supply, V.T.s and C.T.s are normally accommodated in HK Electric 11-kV/22-kV line switch cum metering unit inside HK Electric substation while tariff meters will be installed at the customer's switchroom.
67. Where the supply is designed to be taken from more than one 11-kV/22-kV supply point, the customer is recommended installing interconnection(s) among the 11-kV/22-kV supply points for better security of electricity supply. All incoming and interconnection switchgears/circuit breakers shall be of 3-pole type interrupting all live conductors and mechanically and electrically interlocked to prevent HK Electric 11-kV/22-kV sources from operating in parallel.

68. Miniature Circuit Breakers (MCB) and Moulded Case Circuit Breakers (MCCB) should be equipped with lockable function such that these devices can be locked off and only be able to be unlocked by the use of keys or tools used to lock off these devices.
69. The erection of Electric Vehicle (EV) charging facilities shall comply with the following requirements:-
- a. EV charging facilities are fixed electrical installations and shall comply with the relevant requirements of the Electricity Ordinance (Cap. 406) and its subsidiary Regulations.
 - b. Electrical work on EV charging facilities including design, installation, commissioning, inspection, testing, maintenance, modification and repairing shall be carried out by registered electrical contractors and registered electrical workers of the appropriate grade.
 - c. All EV charging facilities which are connected to, or intended to be connected to HK Electric's supply of electricity must comply with HK Electric's Supply Rules, the Electricity (Wiring) Regulations and other relevant Government Ordinances and Regulations.
 - d. The electrical installations shall comply with the <<Technical Guidelines on Charging Facilities for Electric Vehicles>> and <<Technical Guidelines for Electric Vehicle (EV) Charging-enabling for Car Parks of New Building Developments>> published by the Electrical and Mechanical Services Department and Environment Bureau / Electrical and Mechanical Services Department respectively.
 - e. EV charging facilities shall be supplied and metered appropriately as per HK Electric's requirement.
 - f. Electrical loads of EV charging facilities should be evenly distributed among the three phases as reasonably practicable.
 - g. An earth leakage protective device shall be provided for each final circuit. Residual current device (RCD) with characteristics of type A and residual operating current not exceeding 30 mA is acceptable.

- h. Electric cable of each final circuit shall be selected based on the design current of the EV charging facilities and taking into account the constraint of voltage drop in the circuit in accordance with the relevant requirements of the latest Code of Practice for the Electricity (Wiring) Regulations. A larger size electric cable may be used to facilitate future upgrade. In connection with this, a conductor size suitable for carrying a minimum rated current of 32 A is recommended.
 - i. Means of preventing unauthorized usage of EV charging facilities such as housing the socket outlet in a padlocked box or using an access card for energizing charging facilities may be provided as necessary.
70. The metering arrangement for EV charging facilities shall comply with the following requirements:-
- a. Tariff meters shall be installed in a clean and dry indoor location which is not exposed to weather, mechanical damage, vibrations, extremes of temperature or dampness etc. They shall be under conditions which are suitable for meter installation, reading and maintenance. The meter position shall be readily accessible from communal area at all times with reference to Chapter 5 – Metering Requirements.
 - b. Supply to EV charging facilities should normally be derived from the electric supply equipment installed on the same floor level. HK Electric's meters for individual parking spaces shall be installed inside a communal meter room at each car park level.
 - c. HK Electric's meter shall be electrically connected at a position immediately after the customer's main switch and the metering point of an installation shall be at a position as close to the origin of the supply source as practicable.
 - d. Meter position shall satisfy the requirements for meter reading, meter fixing and meter maintenance. For details, please refer to Drg. No. GCS/5/14, GCS/5/17 and GCS/5/18.
 - e. A meter may be applied for each parking space with EV charging facilities (Refer to Drg. No. GCS/7/01).

- f. A single meter may be applied for several parking spaces with EV charging facilities (Refer to Drg. No. GCS/7/02).
- g. HK Electric may allow customers to install their check meters / timers for recovering electricity consumption charges for EV charging via metered communal installations (Refer to Drg. No. GCS/7/03). This is restricted for EV charging installations only and customers are required to obtain prior approval of HK Electric by submitting a standard form (Form EV1). The recovery of electricity consumption charges for non-EV charging installations is still not allowed.

6.18 Schedule of Drawings - Guidelines on Design of Electrical Installation

<u>Drawing No.</u>	<u>Drawing Title</u>
GCS/6/01	Label for Locking Point of 11-kV/22-kV Interconnection Switch
GCS/6/02	Key Box for 11-kV/22-kV Interconnection Switch
GCS/6/03	Examples of Cable Sizes for the Cables Connecting between HK Electric Transformer and Customer's LV Main Switch
GCS/6/04	Typical Arrangement for Customer's LV Interconnection for a 2-Transformer Substation (P245A/93/R-2)
GCS/6/05	Typical Arrangement for Customer's LV Interconnection for a 3-Transformer Substation (P246A/93/R-2)
GCS/6/06	Typical Arrangement for Customer's LV Interconnection for a 4-Transformer Substation (P247A/93/R-2)
GCS/6/07	HK Electric Standard Locks (CMD_A04110A)
GCS/6/08	Label for Locking Earthing Switch of Customer's 11-kV/22-kV Main Switch
GCS/6/09	Recommended Installation Detail for the Disconnection Link with Insulated Enclosure for Bonding Conductor between HK Electric Earth System and Customer's Main Earth System

GCS/6/10	Suggestions for Design & Installation of LV Single-core Cables to Minimize Electromagnetic Interference (P302/95/R-2)
GCS/6/11	Breaking Capacity of Customer Main Switch
GCS/6/12	Main Switch / Local Riser Switch Arrangement for Buildings
GCS/6/13	Multi-customer Rising Mains System
GCS/6/14	Incorrect Multi-customer Riser Switch
GCS/6/15	Earth Fault Protection for Multi-customer Riser Switch
GCS/6/16	Arrangement of Interconnection Circuit Breaker(s) Between Two or More Supply Sources
GCS/6/17	Changeover Arrangement for Standby Supply
GCS/6/18	Basic Requirements for Temporary Supply Used for Decoration Purpose (Total 2 Sheets)
GCS/6/19	Recommended Design Examples for Connection of Residential Load and Commercial Load within the Same Development (P639/06) (Total 2 Sheets)



NOTE : ALL DIMENSIONS ARE IN mm.

Drg. No. GCS/6/01
LABEL FOR LOCKING POINT OF 11-kV/22-kV
INTERCONNECTION SWITCH

CONSTRUCTION DETAILS OF KEY BOX :

1. MATERIAL : 3-mm TH. MILD STEEL PLATE.
2. FINISHING : TWO COATS RUST-OLEUM 960, RUST INHIBITIVE PRIMER AND TWO COATS BEIGE ENAMEL PAINT SPRAYED ON INNER AND OUTER SURFACES.
3. ALL WELDING CONSTRUCTION.
4. DIMENSIONS IN mm UNLESS OTHERWISE SPECIFIED.

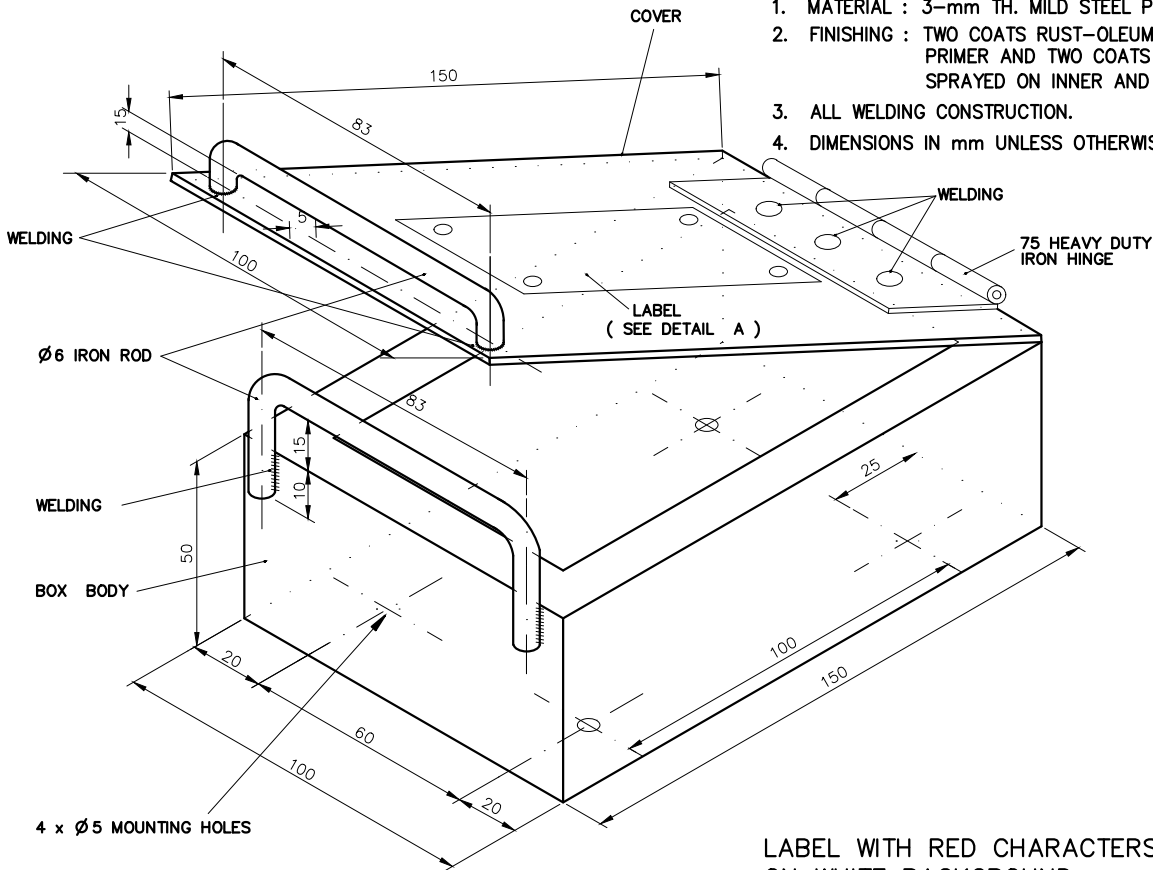

LABEL WITH RED CHARACTERS ON WHITE BACKGROUND
4 x 4.5-mm DIA. HOLE & WITH M4x5 SCREW

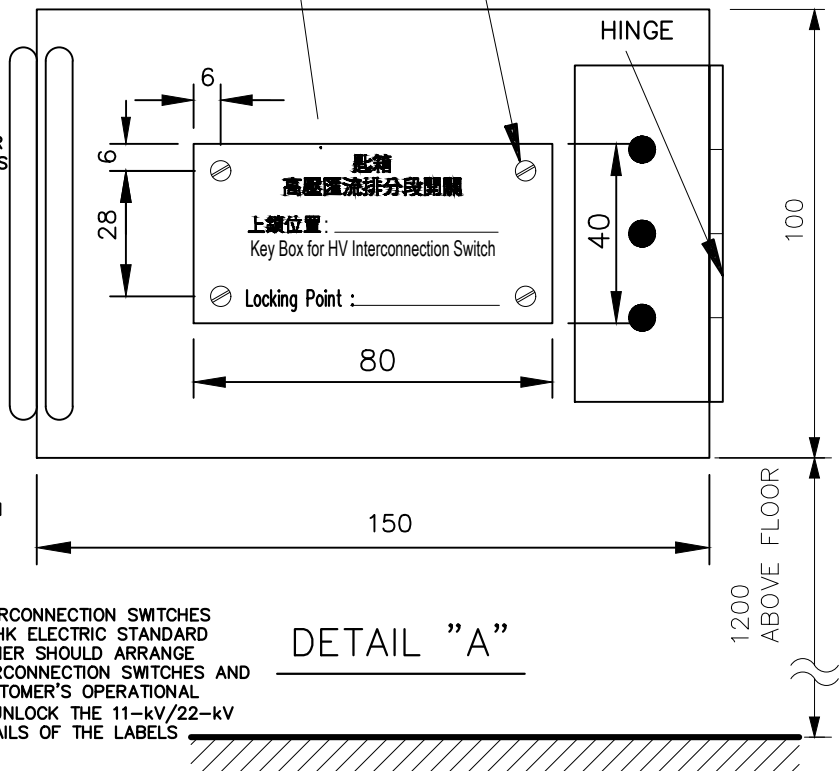

NOTES :

TO PREVENT SUDDEN TRANSFER OF LARGE BLOCK LOAD AMONG THE 11-kV/22-kV SUPPLY POINTS, WHICH COULD OVERLOAD HK ELECTRIC NETWORK AND RESULT IN FURTHER LOSS OF SUPPLY, LOCKING FACILITIES ON THE CUSTOMER'S SWITCHES WHICH ARE INTERCONNECTING DIFFERENT 11-kV/22-kV SUPPLY POINTS ARE REQUIRED. THESE LOCKING FACILITIES SHOULD ONLY BE OPERATED BY HK ELECTRIC AUTHORISED PERSONS INCLUDING IN THE EVENT OF CONTINGENCY.

IN GENERAL, CUSTOMER SHOULD ARRANGE PADLOCKS AT THE ELECTRICAL CONTROL SWITCH AND THE MANUAL OPERATING SWITCH OF THE CUSTOMER'S 11-kV/22-kV INTERCONNECTION SWITCHES.

THE CUSTOMER SHOULD PROVIDE AND INSTALL KEY BOXES, ONE FOR EACH INTERCONNECTION SWITCH. THE KEY BOXES SHOULD BE INSTALLED AT A CONSPICUOUS LOCATION INSIDE THE CUSTOMER'S SWITCHROOM AS CLOSE TO THE RESPECTIVE INTERCONNECTION SWITCHES AS POSSIBLE BUT IN GENERAL SHOULD NOT BE FARTHER THAN 3 m FROM THE RESPECTIVE INTERCONNECTION SWITCHES. THE LAYOUT PLAN OF THE KEY BOXES SHOULD BE SUBMITTED FOR HK ELECTRIC'S PRIOR APPROVAL.

THE KEYS OF PADLOCKS WHICH ARE APPLIED ON THE INTERCONNECTION SWITCHES SHOULD BE KEPT INSIDE THE KEY BOXES RESPECTIVELY. HK ELECTRIC STANDARD LOCKS WILL BE APPLIED TO THE KEY BOXES. THE CUSTOMER SHOULD ARRANGE BILINGUAL LABELS AT THE CONCERNED 11-kV/22-kV INTERCONNECTION SWITCHES AND ON THE WALL ABOVE THE KEY BOXES TO REMIND THE CUSTOMER'S OPERATIONAL STAFF THE REQUIREMENT TO APPROACH HK ELECTRIC TO UNLOCK THE 11-kV/22-kV INTERCONNECTION SWITCHES BEFORE LOAD TRANSFER. DETAILS OF THE LABELS ARE SHOWN IN DRG. NOS. GCS/6/01.

DETAIL "A"

Drg. No. GCS/6/02

KEY BOX FOR 11-kV/22-kV INTERCONNECTION SWITCH

Customer Main Switch Rating	Cables Types ⁽¹⁾	Installation Method ⁽²⁾			
		Horizontal Flat Spaced		Trefoil	
		Minimum Cables Size (mm ²)	No. of cables per Phase	Minimum Cables Size (mm ²)	Cables per Phase
800 Amp.	XLPE	630	1	400	2
	PVC	400	2	630	2
1200 Amp.	XLPE	500	2	400	3
	PVC	400	3	500	4
				630	3
1600 Amp.	XLPE	400	3	500	4
	PVC	500	4	-	-
		630	3		
2250 Amp.	XLPE	630	4	-	-

Notes:

1. The cables are single-core XLPE or PVC insulated copper cables, non-armoured with sheath.
2. Installation methods are based on Method 118 to 120 as stipulated in Appendix 7 of Code of Practice for the Electricity (Wiring) Regulations.
3. The trench is exclusively used by the main cables.
4. The trench shall have sufficient space for the cables.
5. The maximum ambient temperature is 40°C.
6. The maximum length of the main cables is 20 m.
7. If the installation method and/or site condition differs from the above, the figures in the table may not be applicable.
8. The figures in the above table are for general reference only. This shall not circumvent or precede any requirements in the relevant Government Ordinances, the Electricity (Wiring) Regulations and HK Electric's Supply Rules.
9. The installation shall comply with the relevant Government Ordinances, the Electricity (Wiring) Regulations and HK Electric's Supply Rules.

Drg. No. GCS/6/03
EXAMPLES OF CABLE SIZES FOR THE CABLES
CONNECTING BETWEEN HK ELECTRIC TRANSFORMER
AND CUSTOMER'S LV MAIN SWITCH

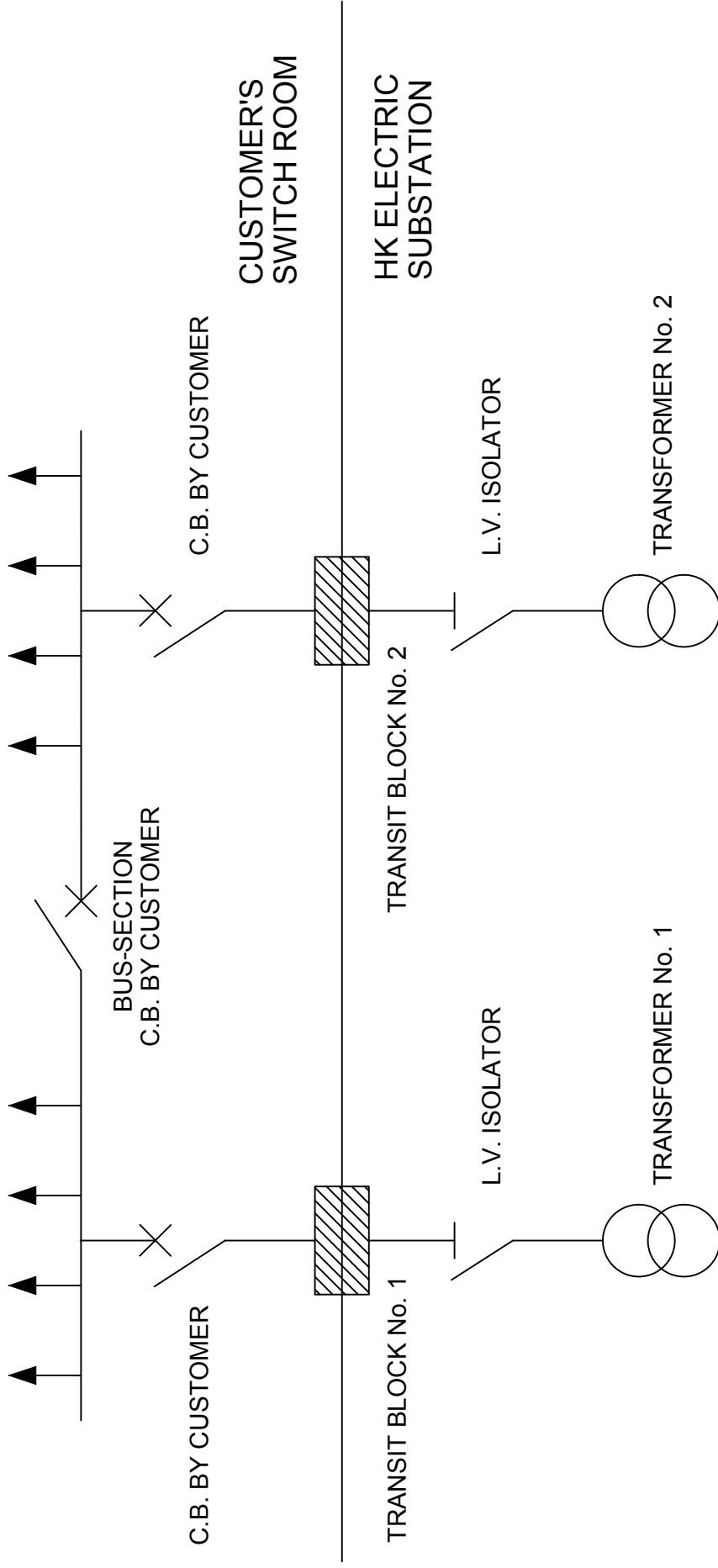

6.32

NEW SUBSTATION

Drg. No. GCS/6/04
TYPICAL ARRANGEMENT FOR CUSTOMER'S LV INTERCONNECTION
FOR A 2-TRANSFORMER SUBSTATION (P245A/93/R-2)

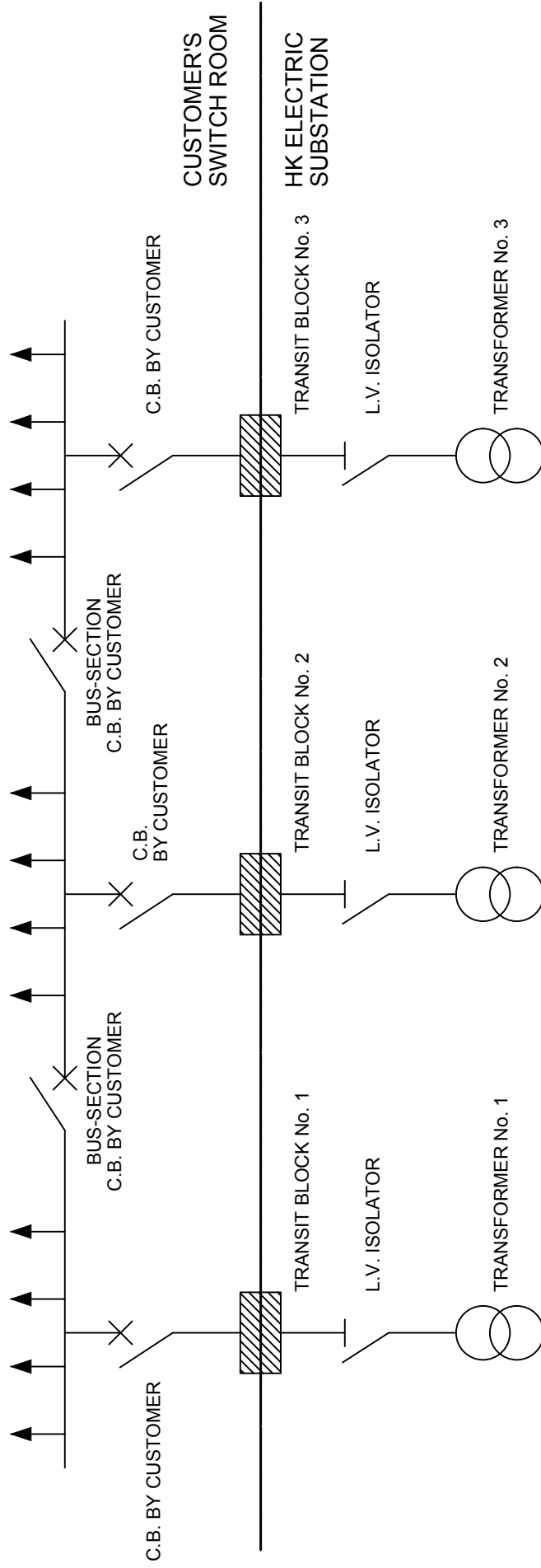

NEW SUBSTATION

Drg. No. GCS/6/05
TYPICAL ARRANGEMENT FOR CUSTOMER'S LV INTERCONNECTION
FOR A 3-TRANSFORMER SUBSTATION (P246A/93/R-2)

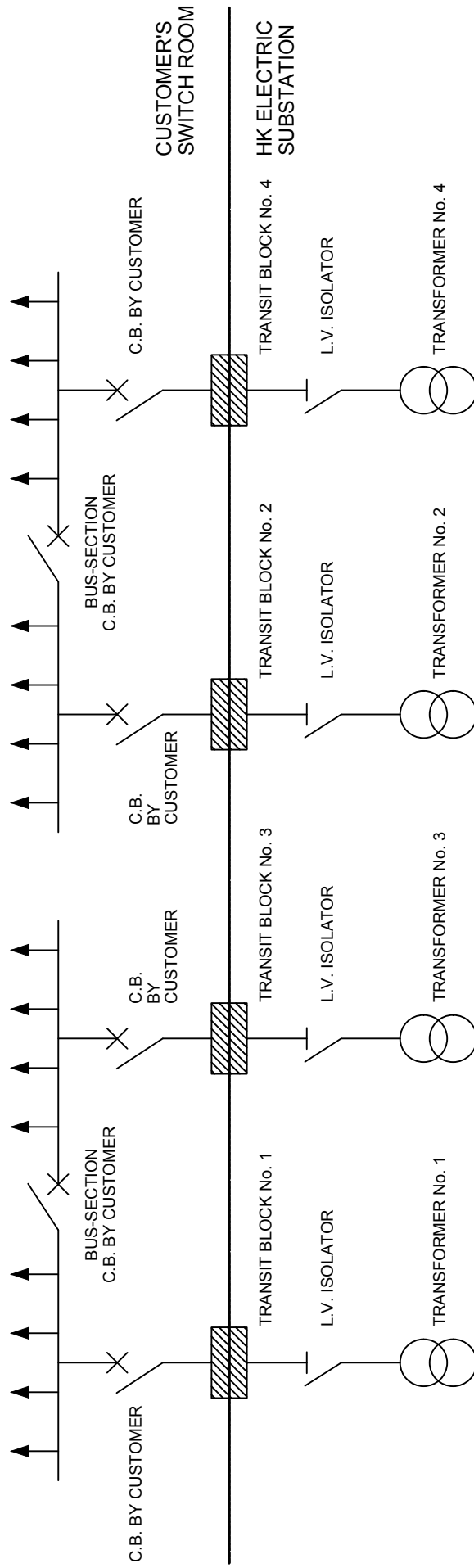

NEW SUBSTATION

Drg. No. GCS/6/06
TYPICAL ARRANGEMENT FOR CUSTOMER'S LV INTERCONNECTION
FOR A 4-TRANSFORMER SUBSTATION (P247A/93/R-2)

STANDARD LOCK MODEL NO. : PL320/20

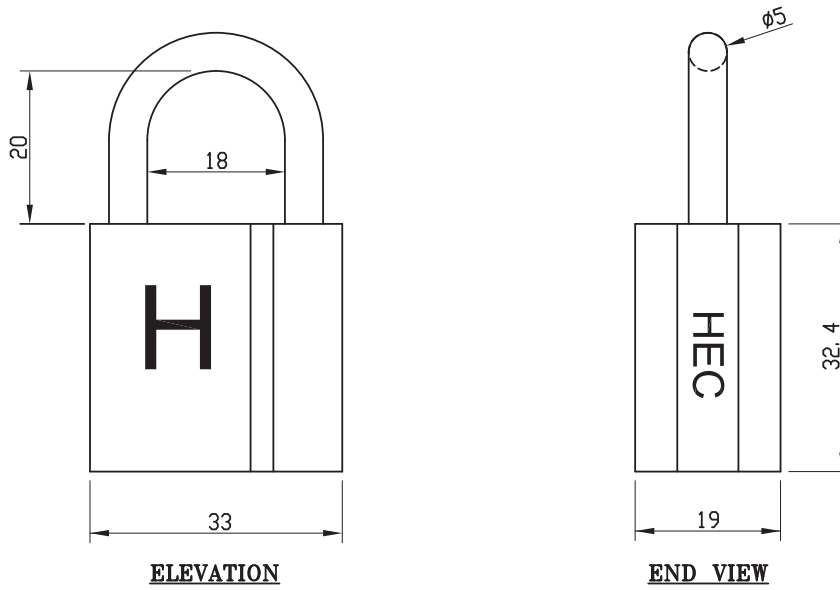

STANDARD LOCK MODEL NO. : PL320/50

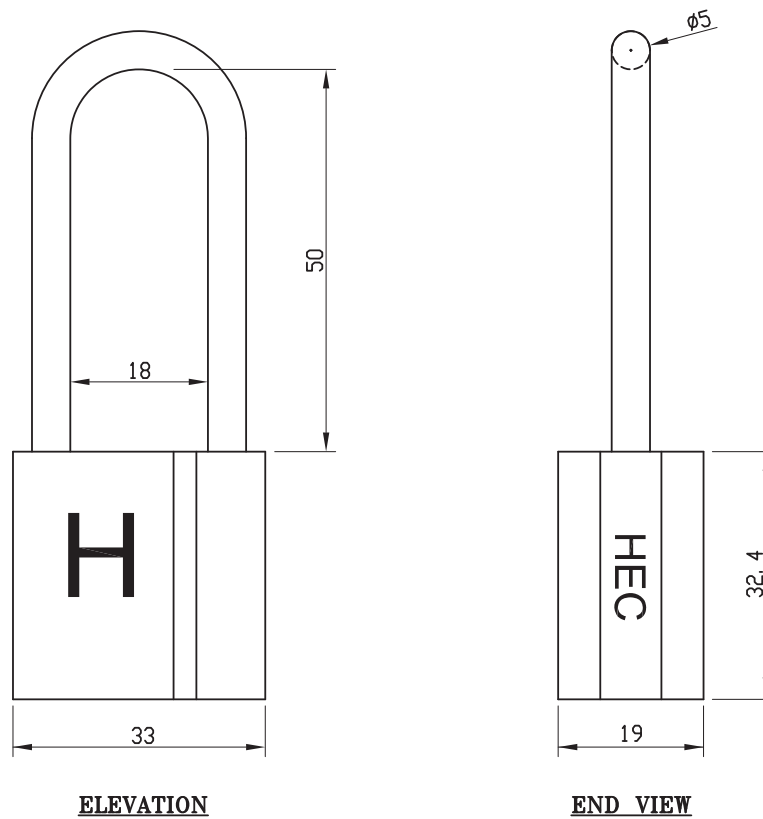

NOTE :

ALL DIMENSIONS ARE IN mm UNLESS OTHERWISE STATED.

Drg. No. GCS/6/07
HK ELECTRIC STANDARD LOCKS (CMD A04110A)



WHITE BACKGROUND
WITH RED CHARACTERS

ENGRAVED BILINGUAL LABEL OF 3-mm-THICK
PLASTIC TO BE FIXED BY 6 SCREWS

NOTES :

1. HK ELECTRIC WILL LOCK THE EARTHING MECHANISM OF THE CUSTOMER'S 11-kV/22-kV INCOMERS EARTH SWITCH TO MAINTAIN IT IN OPEN POSITION IN ORDER TO AVOID INADVERTENT CLOSING OF HK ELECTRIC 11-kV/22-kV SUPPLY TO EARTH WITHOUT THE PERMISSION FROM HK ELECTRIC. THE CUSTOMER'S 11-kV/22-kV INCOMERS SHOULD PROVIDE NECESSARY PROVISIONS TO ACCEPT THE APPLICATION OF EITHER ONE OF THE HK ELECTRIC PROVIDED STANDARD LOCKS AS SHOWN IN DRG. NO. GCS/6/07 TO LOCK THE EARTHING MECHANISM IN OPEN POSITION. THE CUSTOMER SHOULD ALSO ARRANGE BILINGUAL LABEL(S) AS SHOWN IN THIS DRAWING AT THE CONCERNED CUSTOMER'S MAIN SWITCH(ES) .
2. ALL DIMENSIONS ARE IN mm.

Drg. No. GCS/6/08
LABEL FOR LOCKING EARTHING SWITCH OF
CUSTOMER'S 11-kV/22-kV MAIN SWITCH

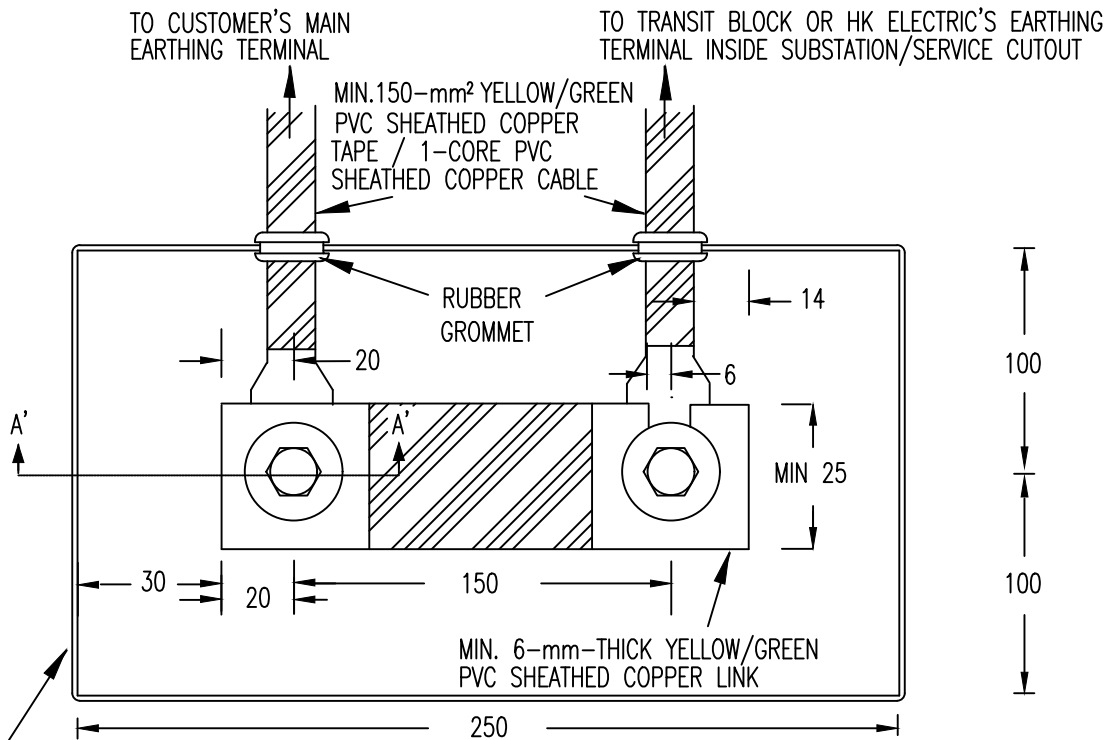

INSULATED ENCLOSURE COMPLETE WITH SCREW FIXED COVER AND A BILINGUAL LABEL :
 「接駁香港電燈有限公司接地系統與大廈總接地系統的接駁導線切斷連桿 — 切勿移去」
 "Isolating Link for Bonding Conductor Between HK Electric Earth System and Building Main Earth System - DO NOT REMOVE"

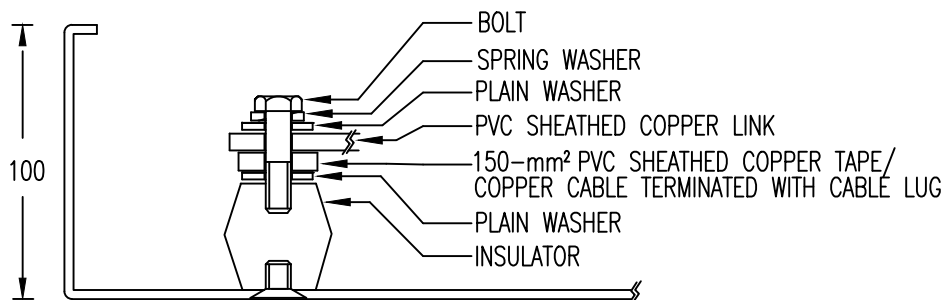

Sectional Elevation A-A'

NOTES:

1. All dimensions are in mm.
2. Where the supply is taken directly from HK Electric transformer(s) within the premises in which the installation is situated. The position of the disconnection link should be installed near the customer's main earth terminal.
3. Where the supply is taken from HK Electric's service cutout having exposed conductive parts, the position of the disconnection link should be installed near the bonding terminal provided by HK Electric.

Drg. No. GCS/6/09
RECOMMENDED INSTALLATION DETAIL FOR THE
DISCONNECTION LINK WITH INSULATED ENCLOSURE FOR
BONDING CONDUCTOR BETWEEN HK ELECTRIC EARTH SYSTEM
AND CUSTOMER'S MAIN EARTH SYSTEM

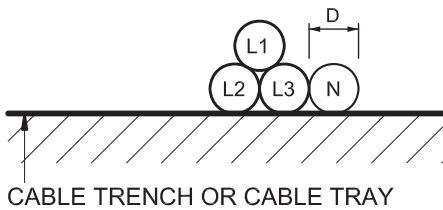

LEGEND:

- L1 = PHASE 1 OF 3-PHASE CIRCUIT
- L2 = PHASE 2 OF 3-PHASE CIRCUIT
- L3 = PHASE 3 OF 3-PHASE CIRCUIT
- N = NEUTRAL
- D = DIAMETER OF SINGLE-CORE CABLES

ONE CABLE PER PHASE

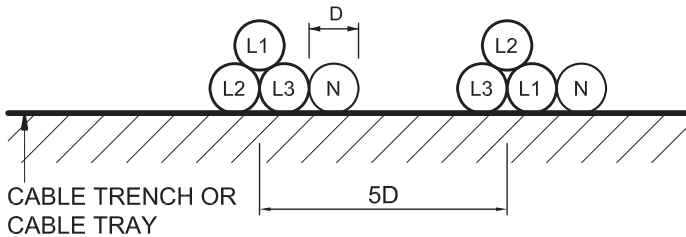

TWO CABLES IN PARALLEL PER PHASE

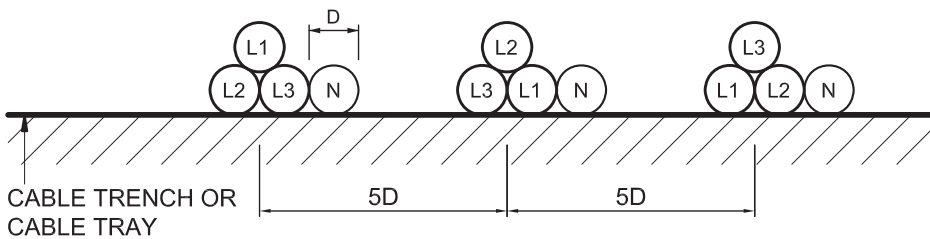

THREE CABLES IN PARALLEL PER PHASE

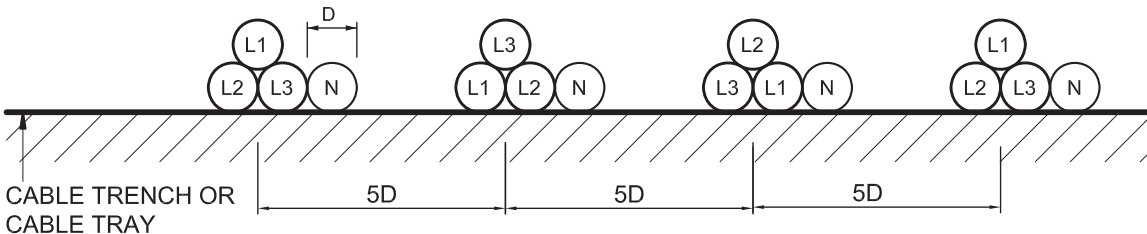

FOUR CABLES IN PARALLEL PER PHASE

NOTES:

TO MINIMIZE THE ELECTROMAGNETIC INTERFERENCE GENERATED FROM SINGLE-CORE CABLES, IT IS SUGGESTED TO IMPLEMENT THE FOLLOWING MEASURES IN THE DESIGN AND INSTALLATION OF THE CABLES:

- 1) ALL THE SINGLE-CORE CABLES SHOULD BE OF SAME CONDUCTOR, SAME CROSS SECTIONAL AREA, SAME TYPE, SAME CONSTRUCTION AND FROM THE SAME MANUFACTURER.
- 2) ALL THE SINGLE-CORE CABLES SHOULD BE OF EQUAL LENGTH AND FOLLOW THE SAME ROUTE OF INSTALLATION.
- 3) THE SINGLE-CORE CABLES MUST NOT BE ABLE TO OPERATE INDIVIDUALLY.
- 4) THE LAYOUT OF SINGLE-CORE CABLES SHOULD BE ARRANGED AS SHOWN IN THIS DRAWING.

Drg. No. GCS/6/10

SUGGESTIONS FOR DESIGN & INSTALLATION OF LV SINGLE-CORE CABLES TO MINIMIZE ELECTROMAGNETIC INTERFERENCE

(P302/95/R-2)

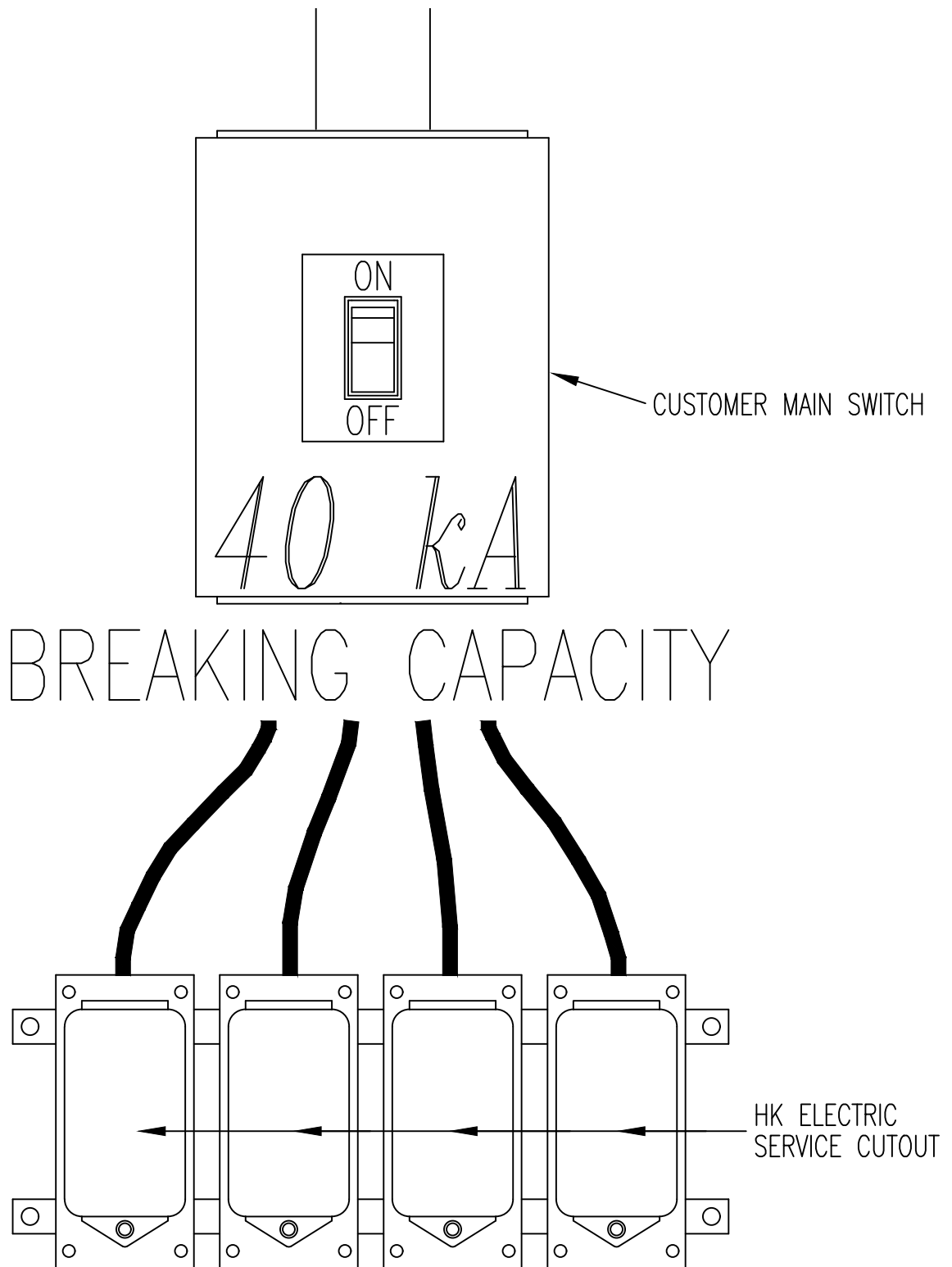

WHERE SUPPLY IS TAKEN DIRECTLY FROM HK ELECTRIC SERVICE CABLE,
 THE MAIN SWITCH SHALL HAVE A SHORT-CIRCUIT BREAKING CAPACITY OF
 40 kA SYMMETRICAL AT LOW VOLTAGE.

Drg. No. GCS/6/11
BREAKING CAPACITY OF CUSTOMER MAIN SWITCH

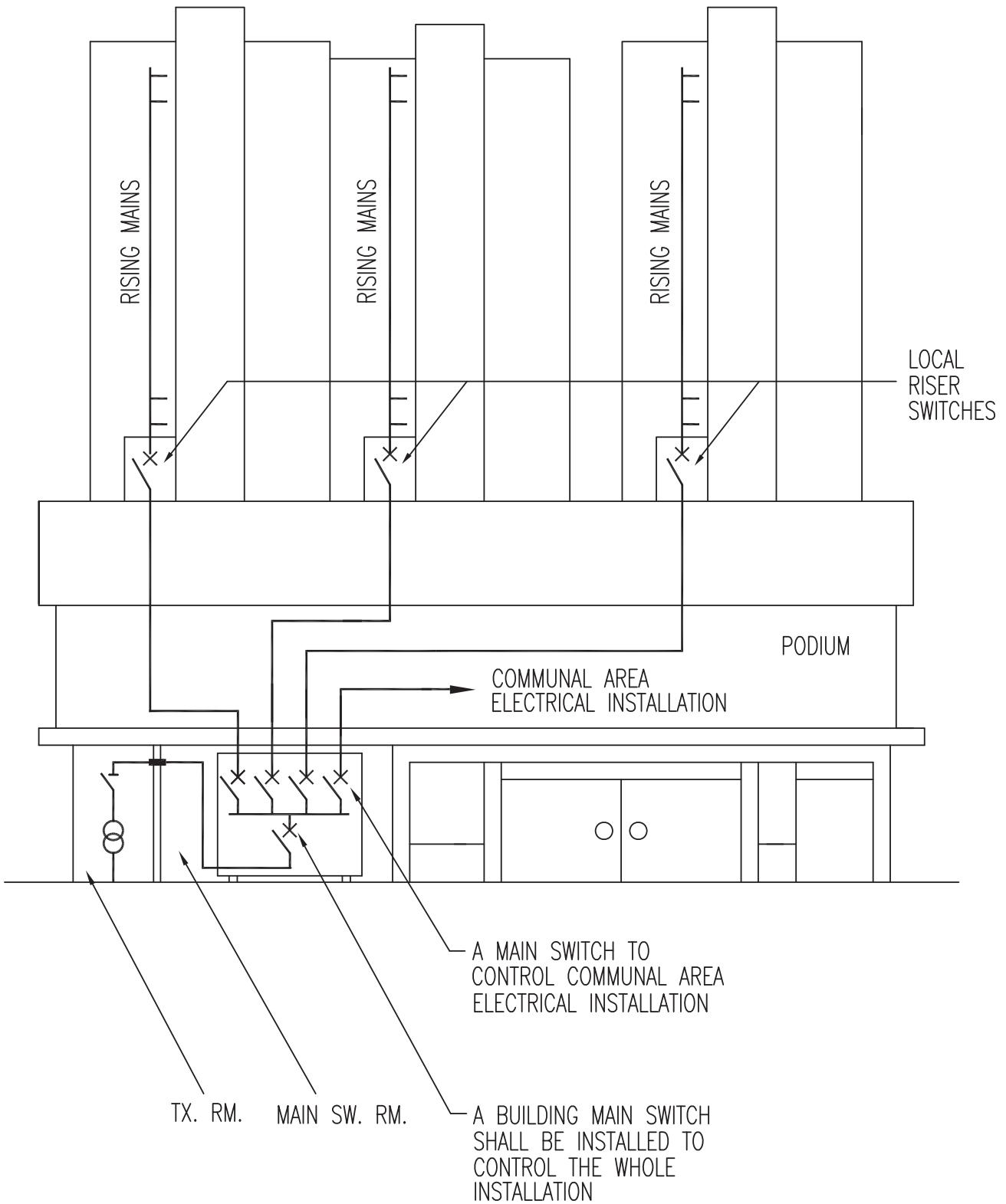

Drg. No. GCS/6/12
MAIN SWITCH / LOCAL RISER SWITCH ARRANGEMENT
FOR BUILDINGS

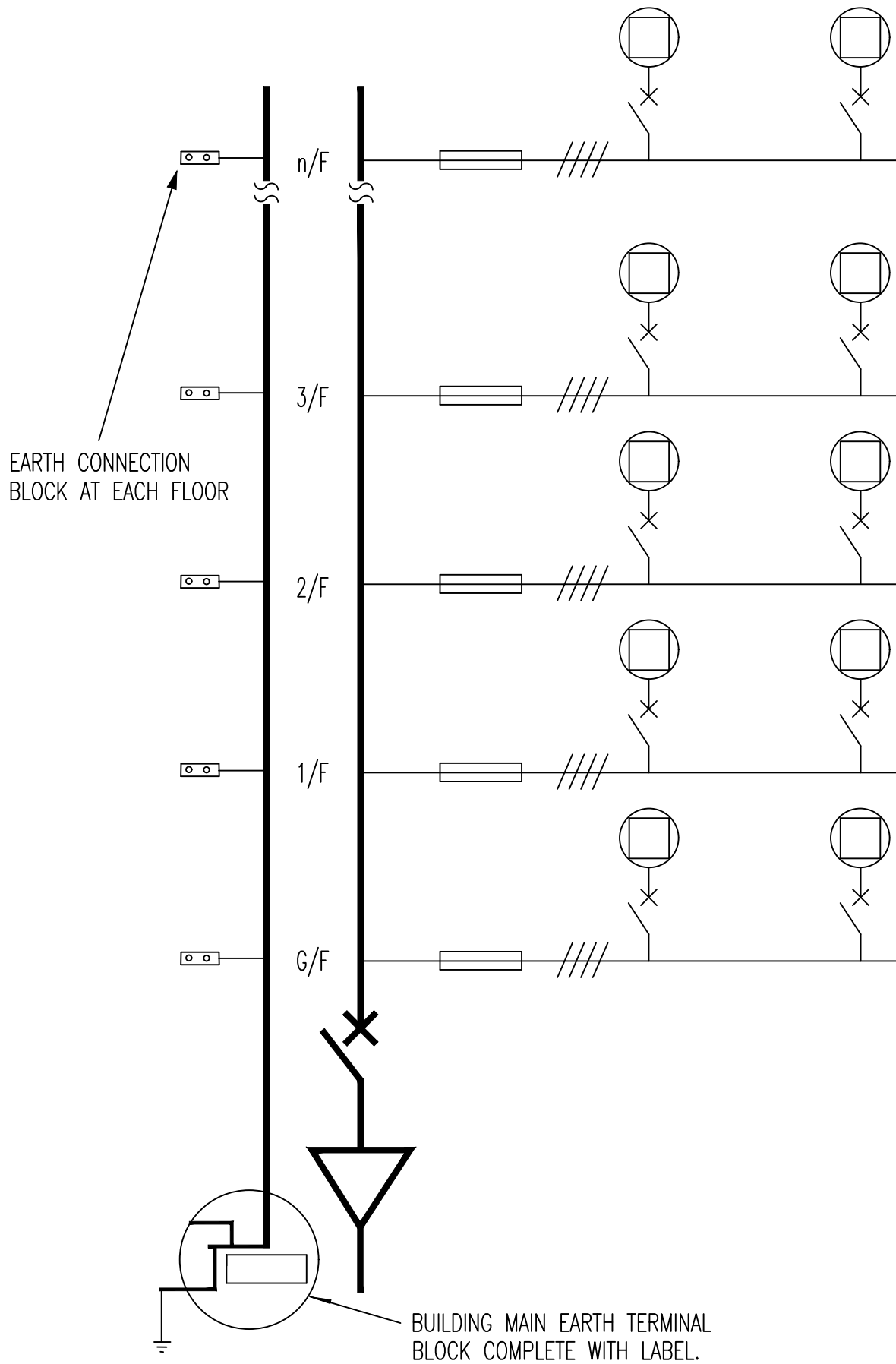

Drg. No. GCS/6/13
MULTI-CUSTOMER RISING MAINS SYSTEM

RISING MAINS

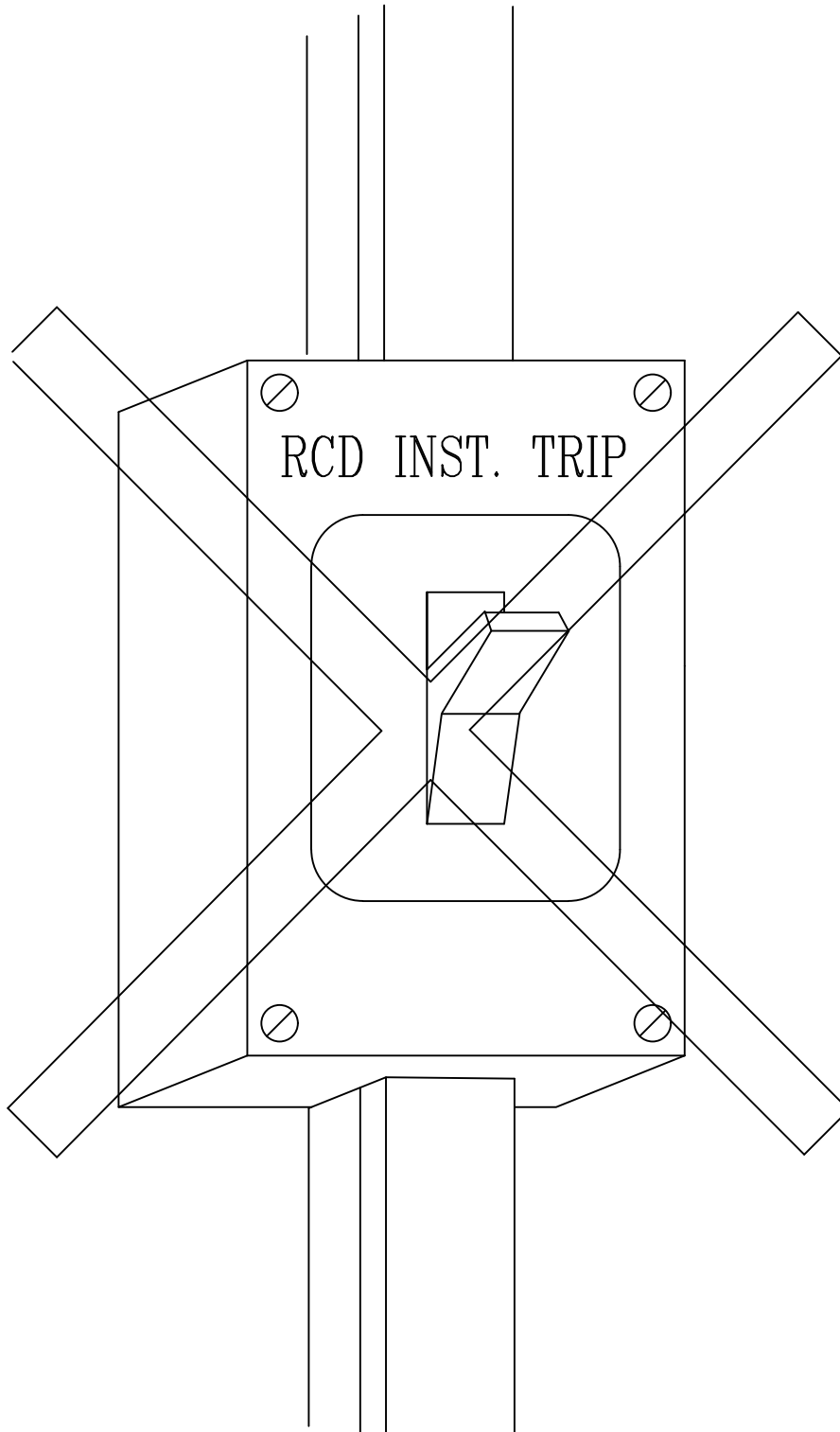

INSTANTANEOUS TYPE RCD SHALL NOT BE
USED AS MULTI-CUSTOMER RISER SWITCH.

Drg. No. GCS/6/14
INCORRECT MULTI-CUSTOMER RISER SWITCH

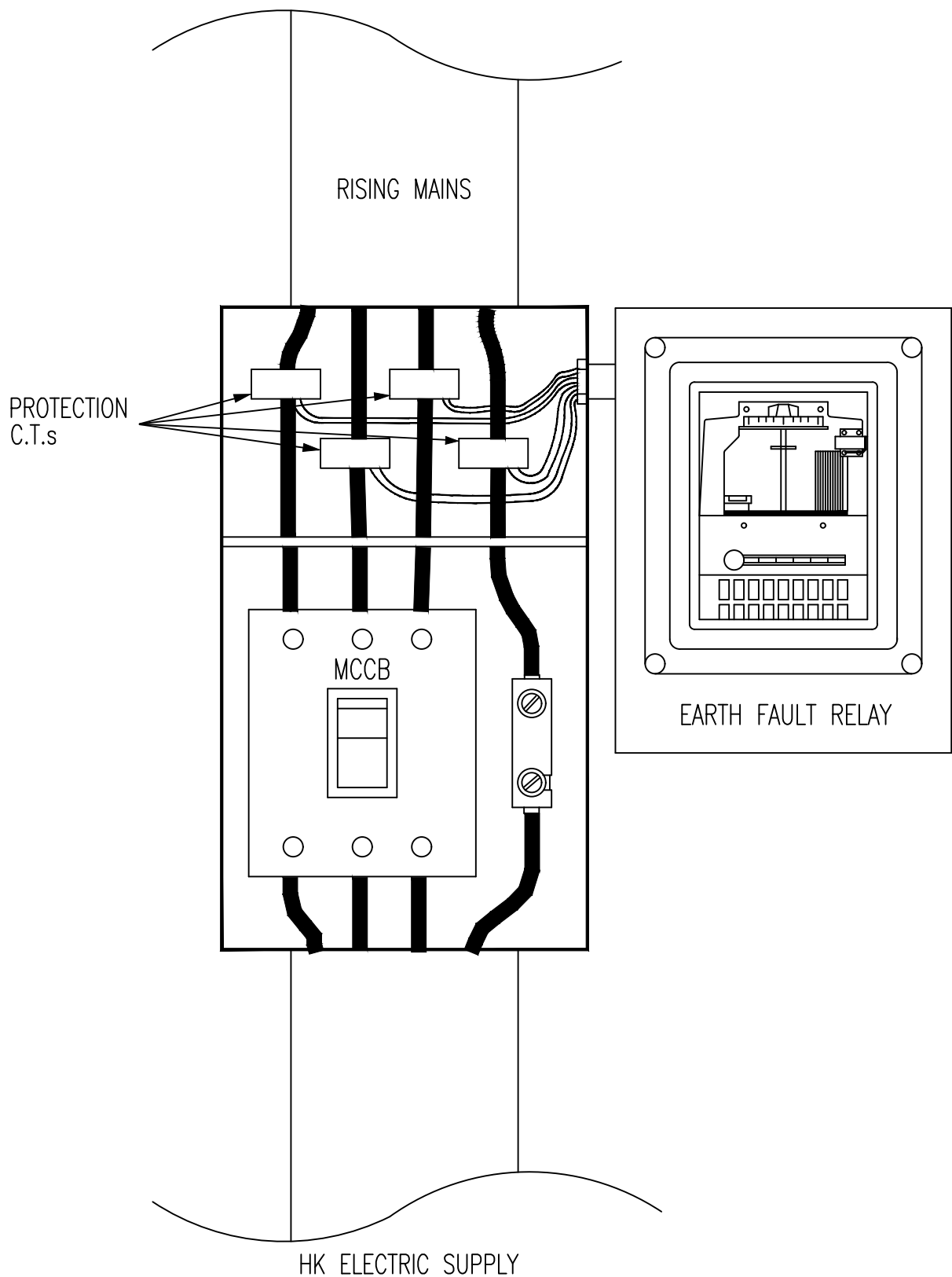

EARTH FAULT RELAY ASSOCIATED WITH PROTECTION C.T.s COULD BE USED TO ACHIEVE AUTOMATIC DISCONNECTION WITHIN 5 SECONDS DURING AN EARTH FAULT

Drg. No. GCS/6/15
EARTH FAULT PROTECTION FOR MULTI-CUSTOMER
RISER SWITCH

INTERCONNECTION CIRCUIT BREAKER(S) BETWEEN
2 OR MORE SUPPLY SOURCES SHALL BE OF
4-POLE TYPE WITH MECHANICAL AND ELECTRICAL INTERLOCKS

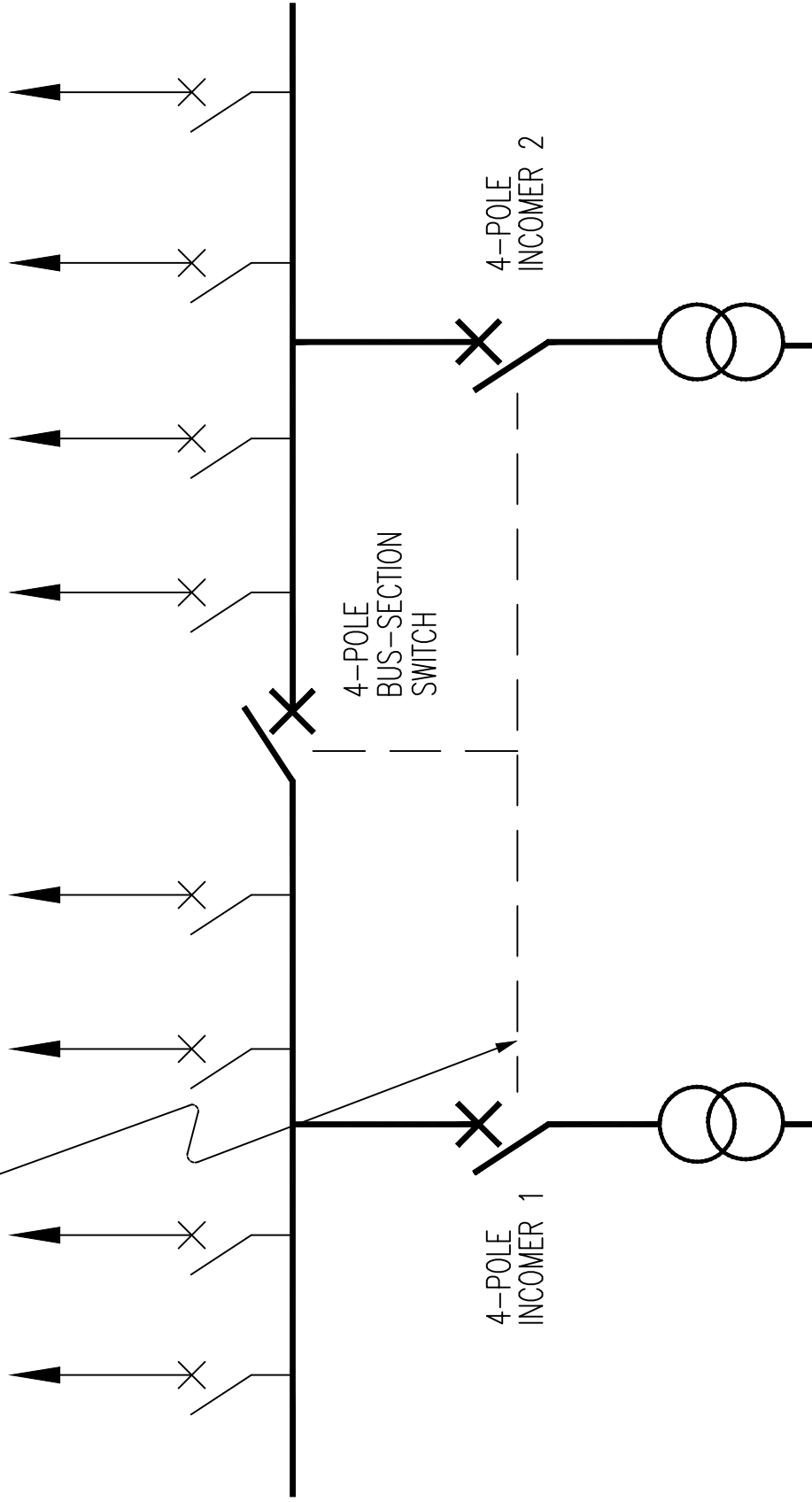

Drp. No. GCS/6/16

ARRANGEMENT OF INTERCONNECTION CIRCUIT BREAKER(S) BETWEEN
TWO OR MORE SUPPLY SOURCES

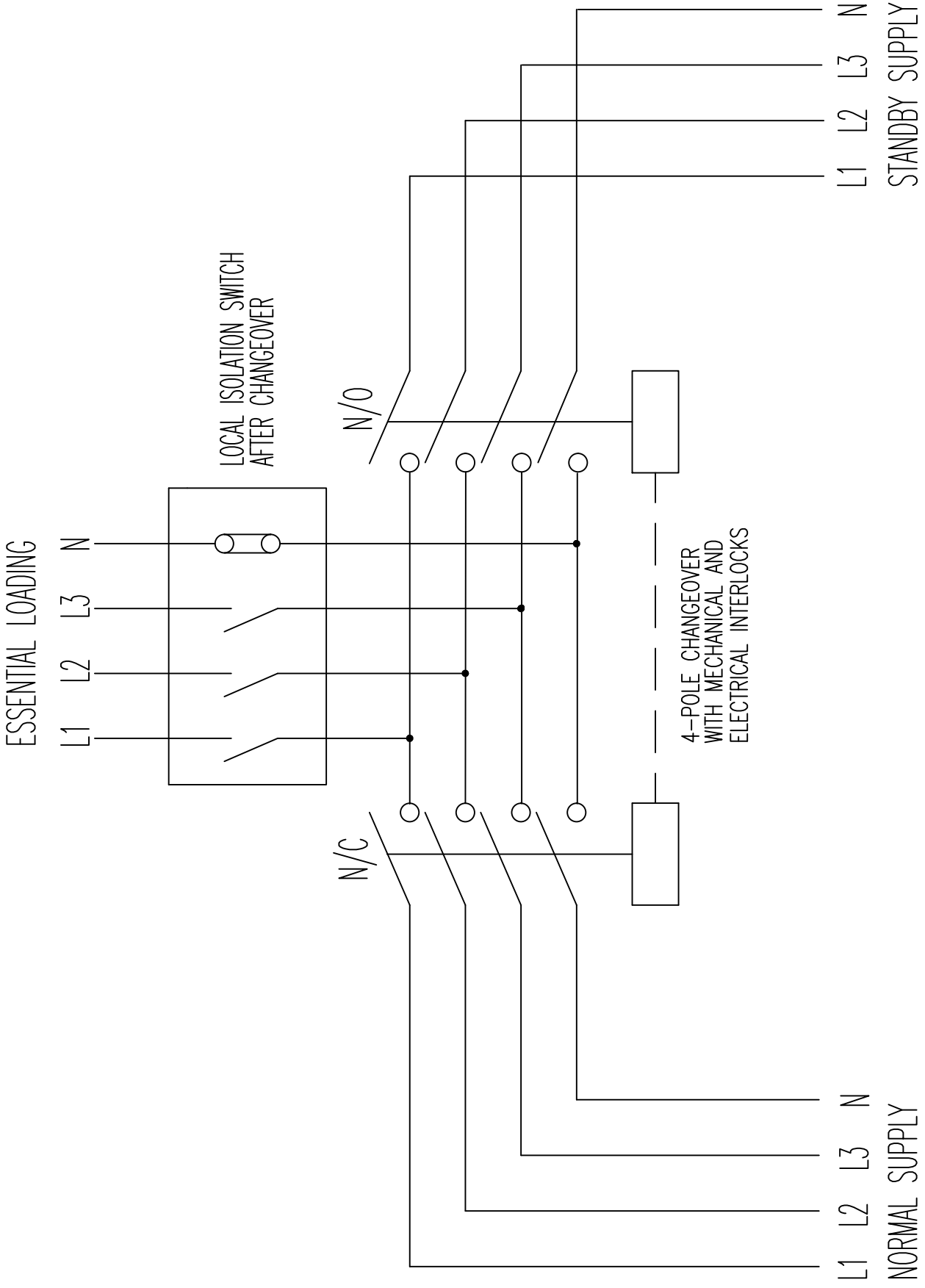

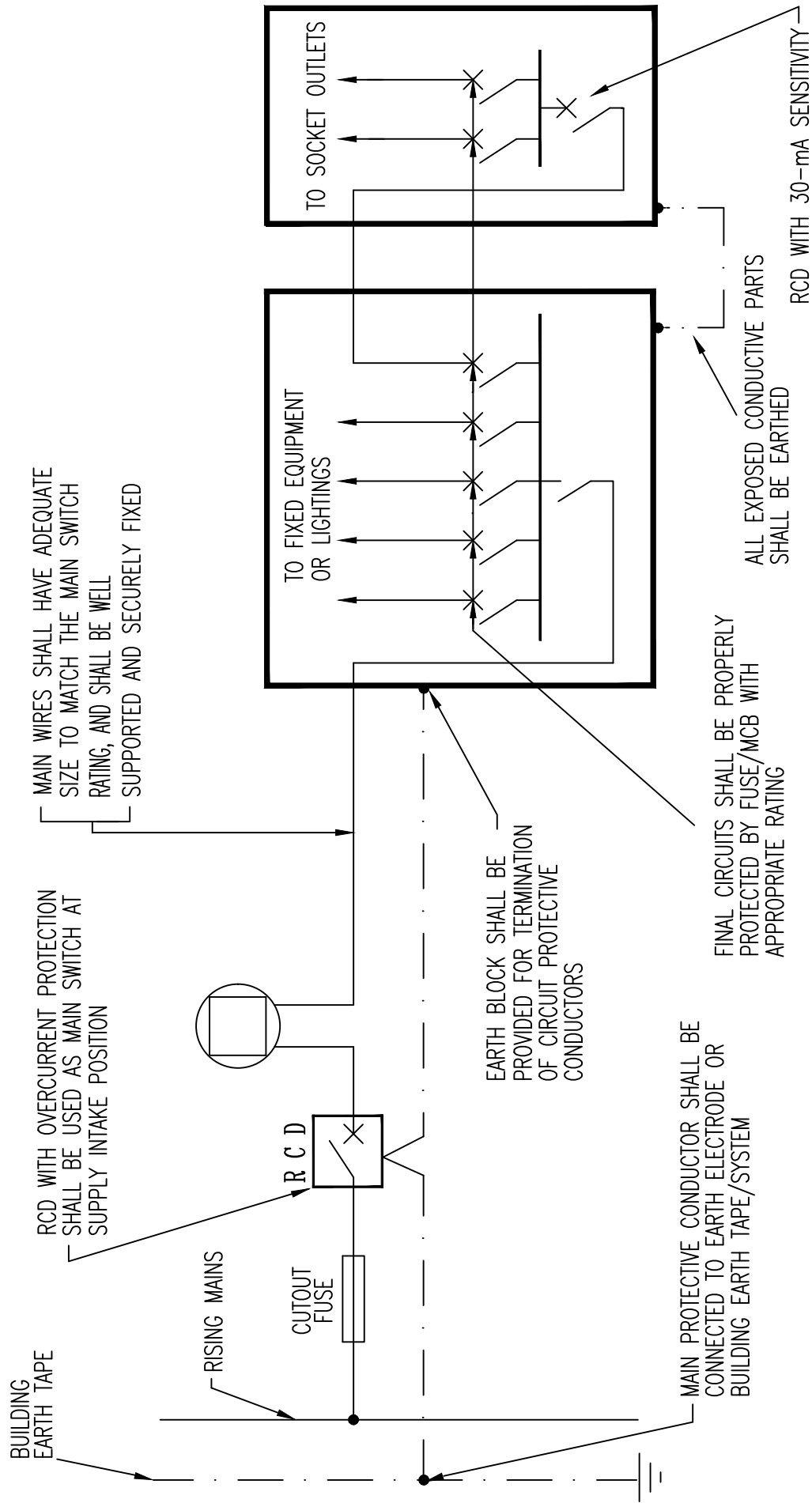

Drg. No. GCS/6/18
BASIC REQUIREMENTS FOR TEMPORARY SUPPLY USED FOR DECORATION PURPOSE
SHEET 1 OF 2

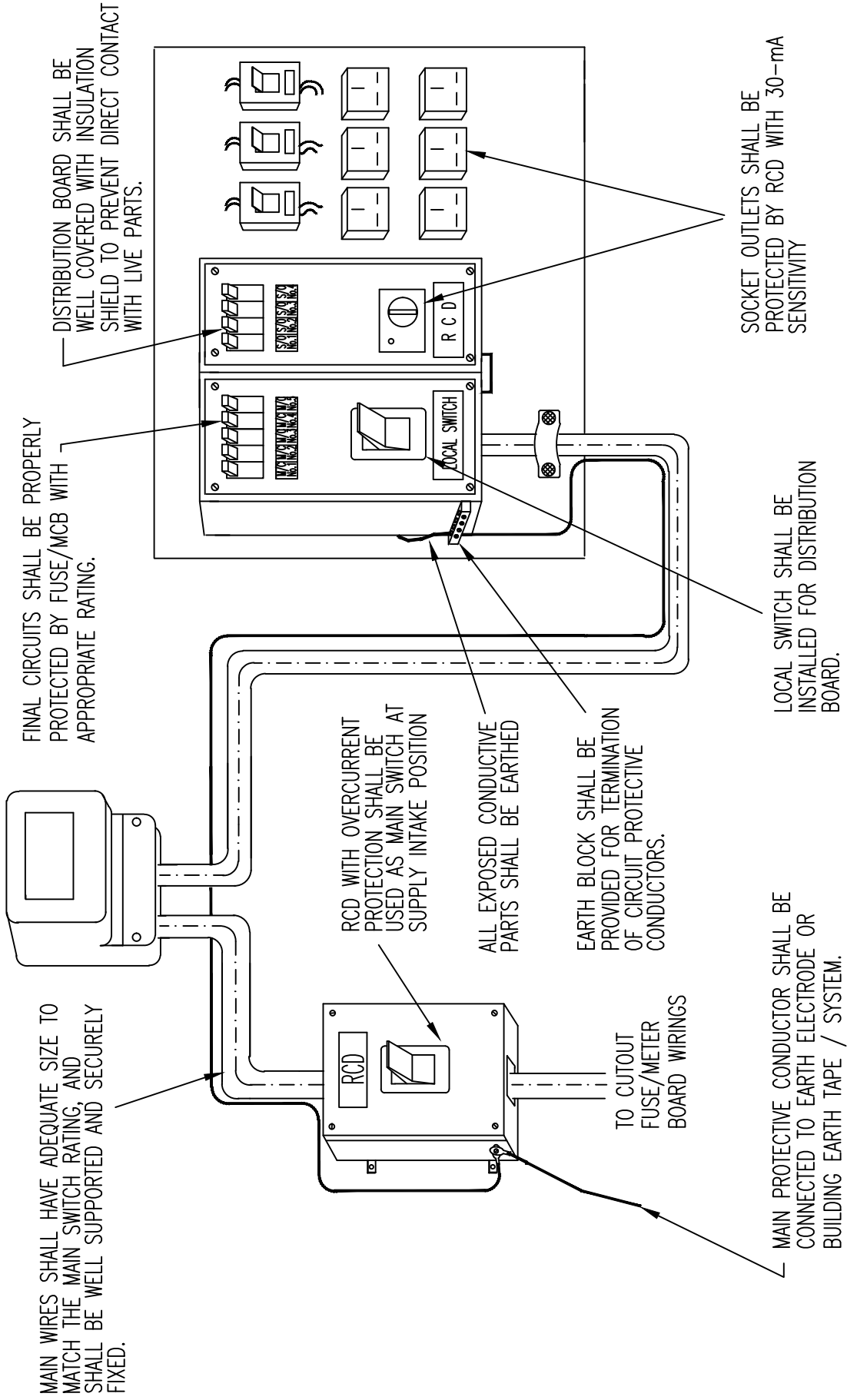

Drg. No. GCS/6/18

BASIC REQUIREMENTS FOR TEMPORARY SUPPLY USED FOR DECORATION PURPOSE

SHEET 2 OF 2

EXAMPLE 1

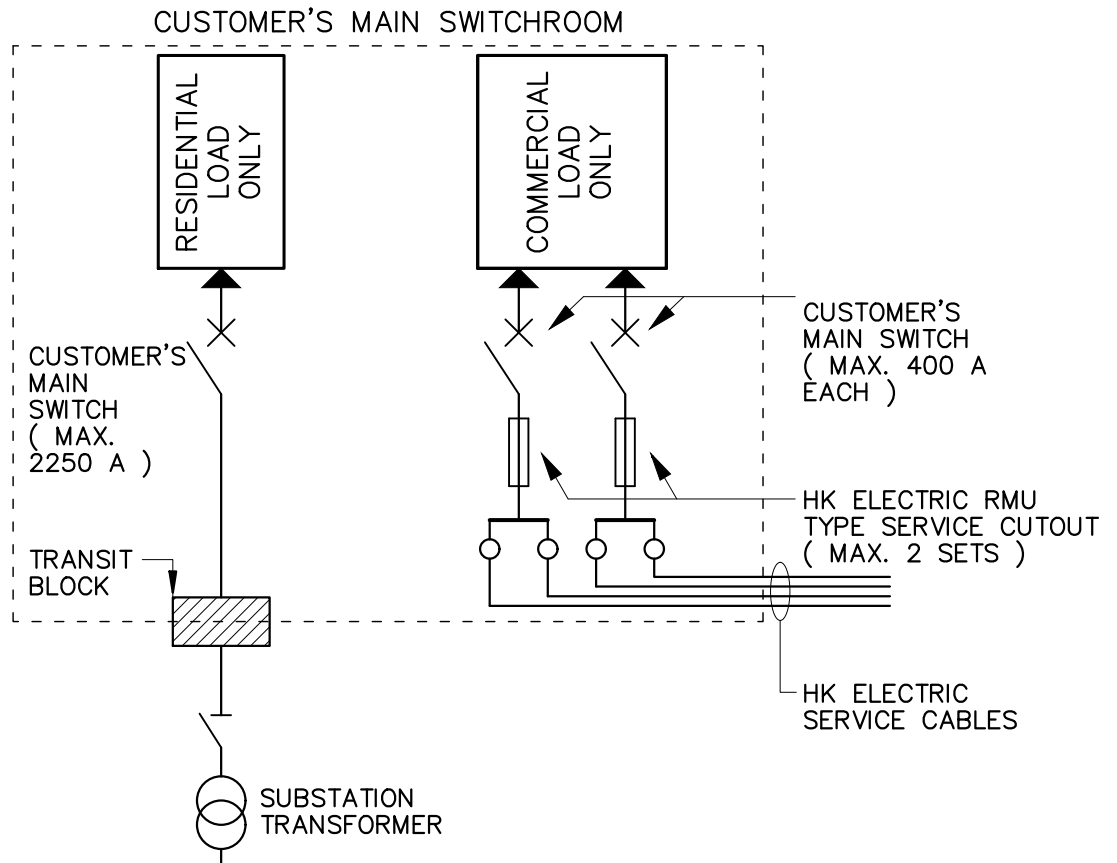

EXAMPLE 2

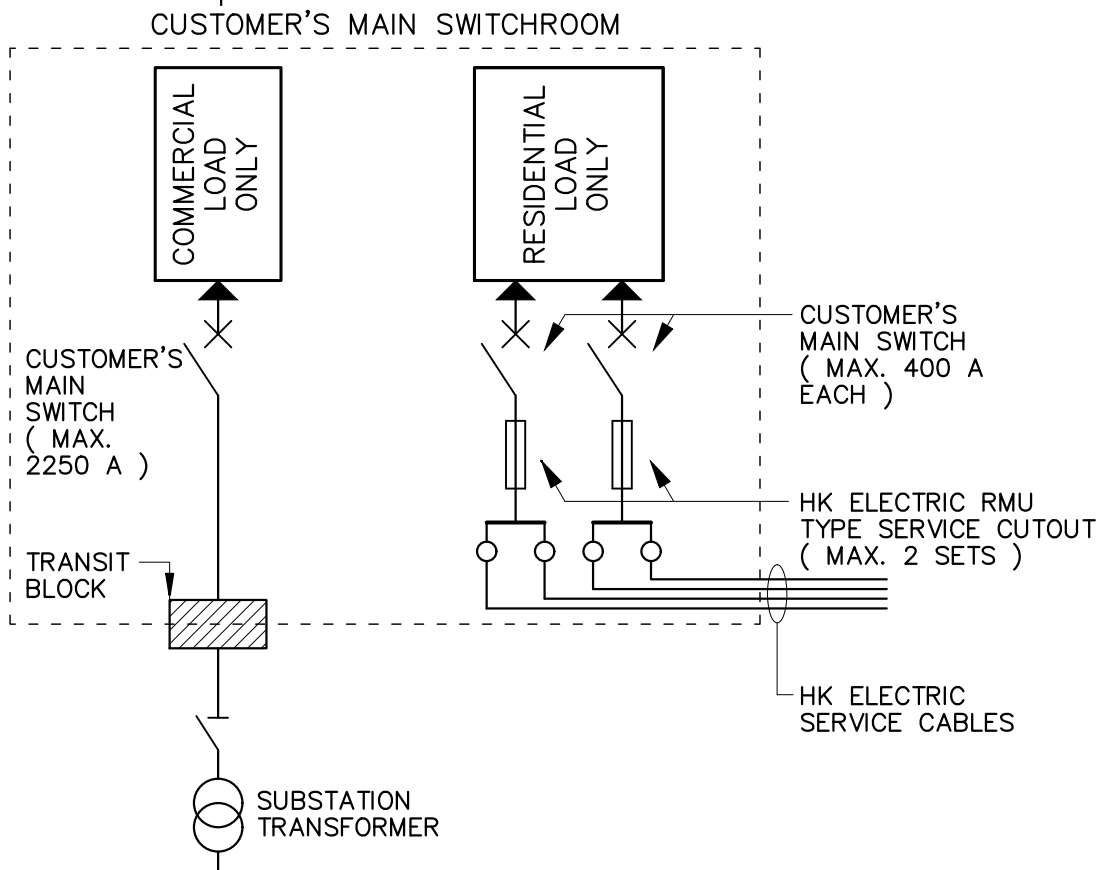

Drg. No. GCS/6/19

RECOMMENDED DESIGN EXAMPLES FOR CONNECTION OF RESIDENTIAL LOAD AND COMMERCIAL LOAD WITHIN THE SAME DEVELOPMENT (P639/06) SHEET 1 OF 2

EXAMPLE 3

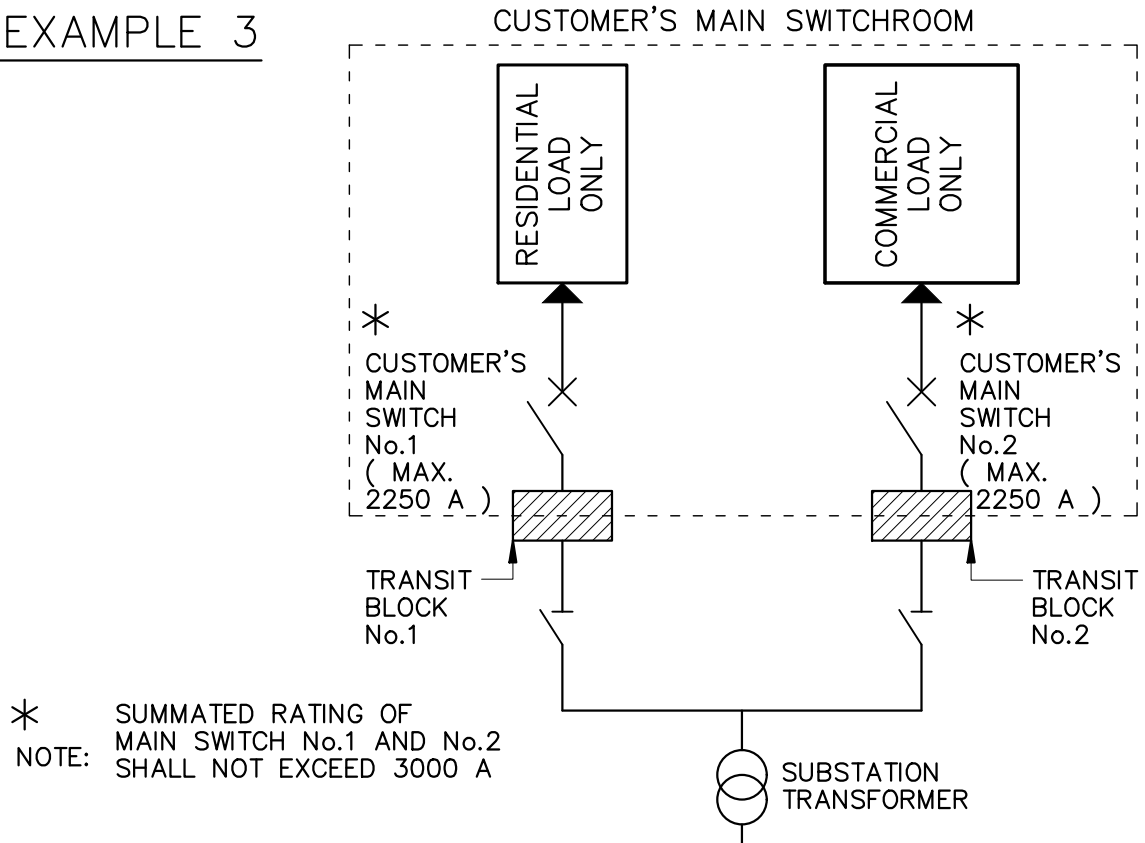

EXAMPLE 4

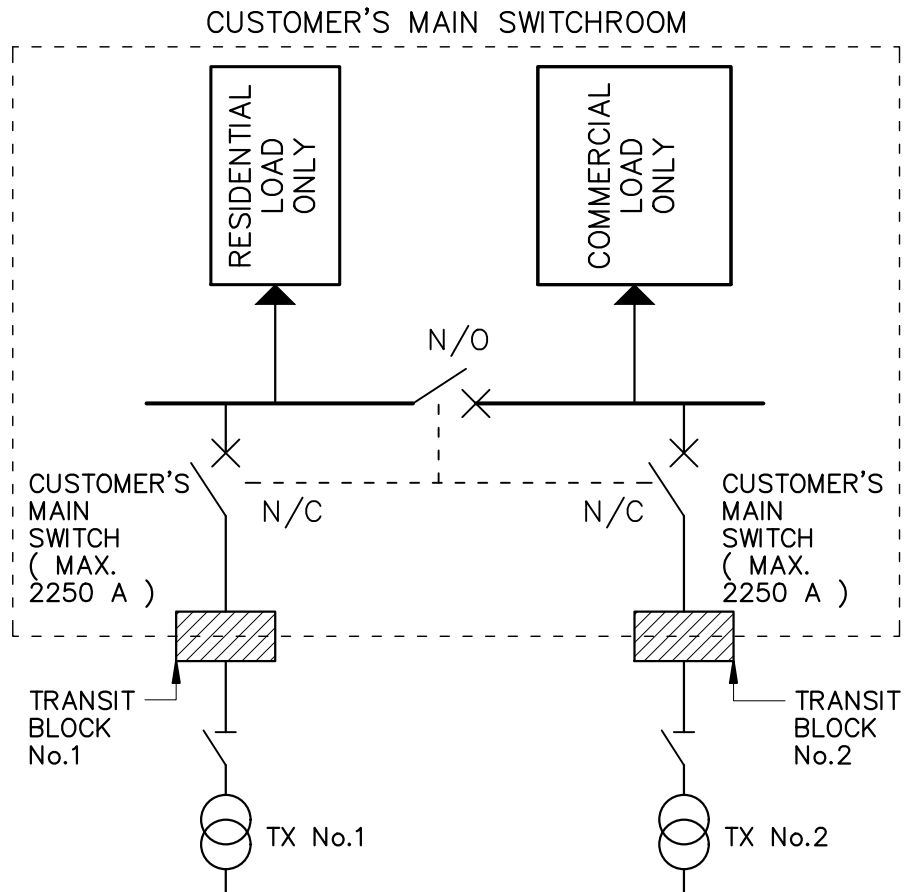

Drg. No. GCS/6/19

RECOMMENDED DESIGN EXAMPLES FOR CONNECTION OF RESIDENTIAL LOAD AND COMMERCIAL LOAD WITHIN THE SAME DEVELOPMENT (P639/06) SHEET 2 OF 2