

Chapter – 6 Screw Compressors

Copy Right By:
Thomas T.S. Wan
温到祥 著
Sept. 3, 2008
All rights reserved

Screw compressors are the most widely used compressors for industrial refrigeration application in the world because of the favorable features of variable head and variable volume characters. Screw compressor practically replaces almost all the applications that used to the areas of reciprocating compressor in industrial refrigeration in recent decade.

Screw compressor was invented long time ago. It was based on dry compression; that is the compressor is with a set of timing gears to ensure that no contacts between the twin rotors of the compressor. The earlier design screws were mostly used and still being used for air and gas compression in oil refinery, petrochemical and gas processing industries. It was not used by refrigeration industries due to various difficulties including high cost.

Oil Injection (Oil Flooded) for screw compressor was invented in 1950's. It eliminated the timing gears, increasing the compression ratio and reducing the discharge temperature for the compressor. But, it was still not good enough for refrigeration application, because of oil carry over problem and lack of capacity control capability for partial load operation.

The adaptation of the screw compressor for refrigeration duty was made possible in 1970's after the new inventions plus the further improvements made to the screw compressor. Those major invention and improvement were: The hydraulically operated capacity control; economizer cycle improves compressor efficiency to a point comparable to two-stage; improvements on compressor discharge oil filter, variable V_i , better control by using microprocessor panel and etc.

There are two types of open oil flooded screw compressor available for industrial refrigeration application do-day; one is the Twin-Rotor screw and the other is the Single-Rotor screw. Twin-rotor screw is the most widely used compressor for industrial refrigeration installations worldwide, particularly larger size installations.

FIG. 6.1 shows the typical construction of the twin-rotor screw compressor; FIG. 6.2 shows the typical Asymmetric Twin-Rotor Profile; some manufacturers use other rotor profile such as 4+6 "A" or 5+7 "D" rotor profile or others. FIG. 6.3 is a typical construction of Single-Rotor screw compressor.

The compressor shown in FIG. 6.1 is a bare screw compressor; it can not be used for refrigeration. The screw compressor only can become useful if it is equipped with other necessary subsystems becoming a "compressor unit" as shown in FIG. 6.4. A typical "compressor unit" consists of other subsystems as the following:

- Screw Compressor.
- Driving Motor & Power Supply System.
- Lubrication System.
- Oil Reservoir & Oil Separation System.
- Hydraulic System.
- Oil Cooling & Filtering System.
- Suction and Discharge Valves and Strainer.
- Microprocessor Control Panel and Control System.

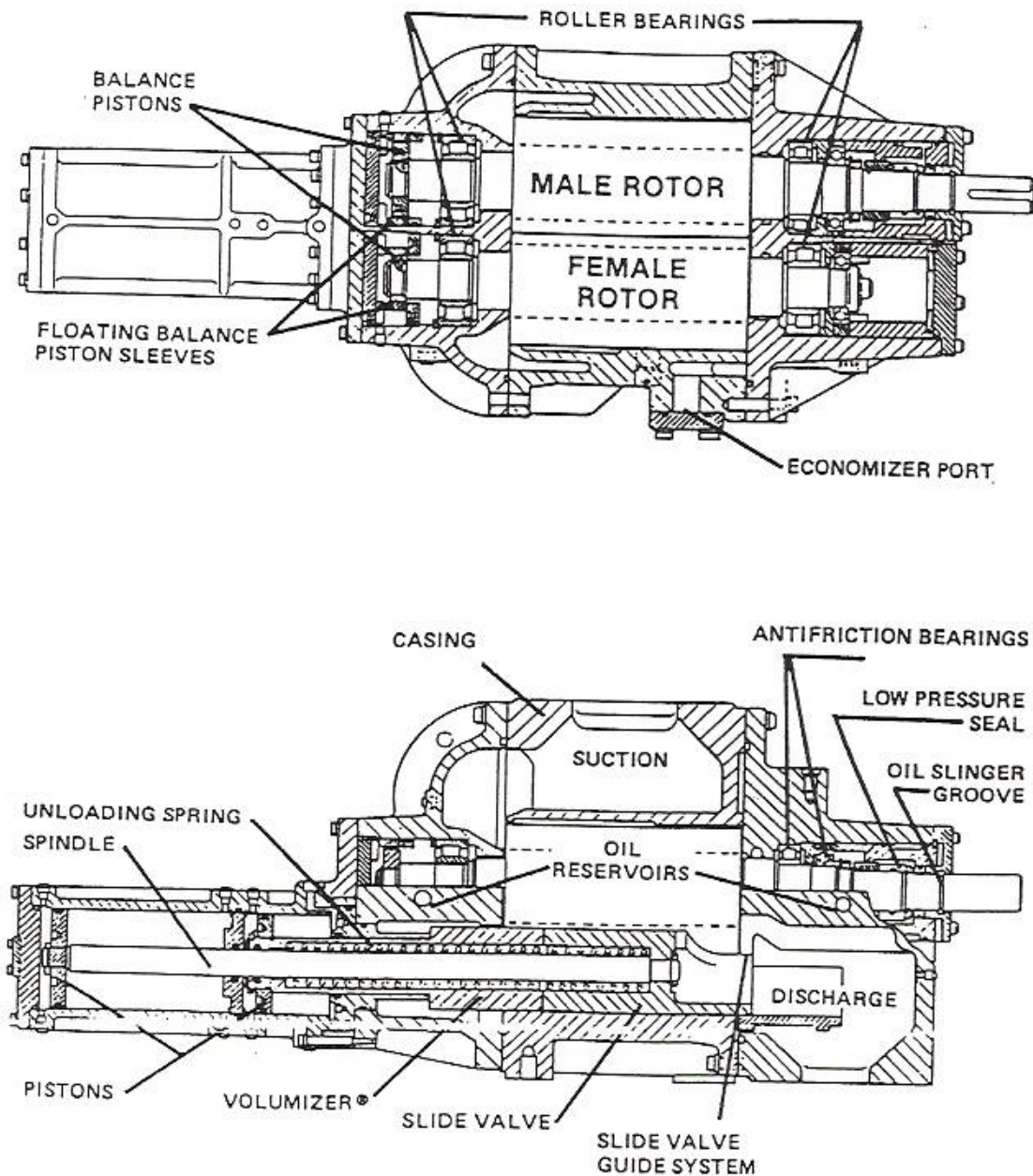

FIG. 6.1 Typical Twin-Rotor Screw Compressor Construction

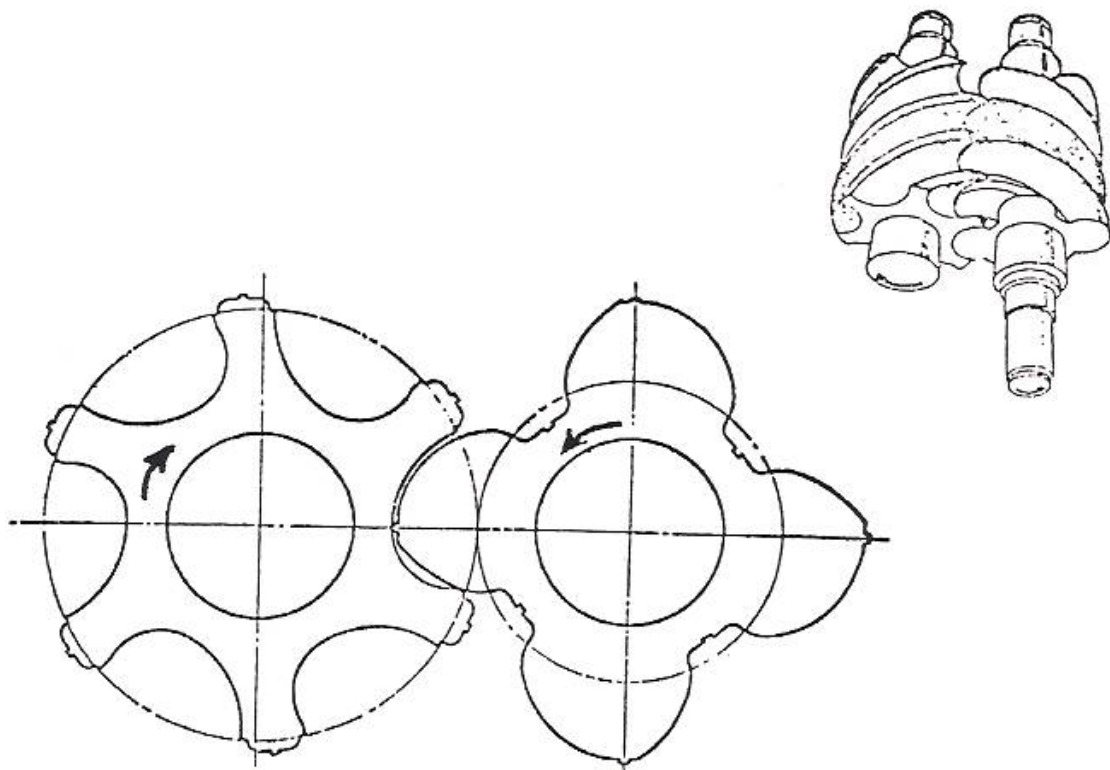

FIG. 6.2 Typical Asymmetric Twin-Rotor Profile

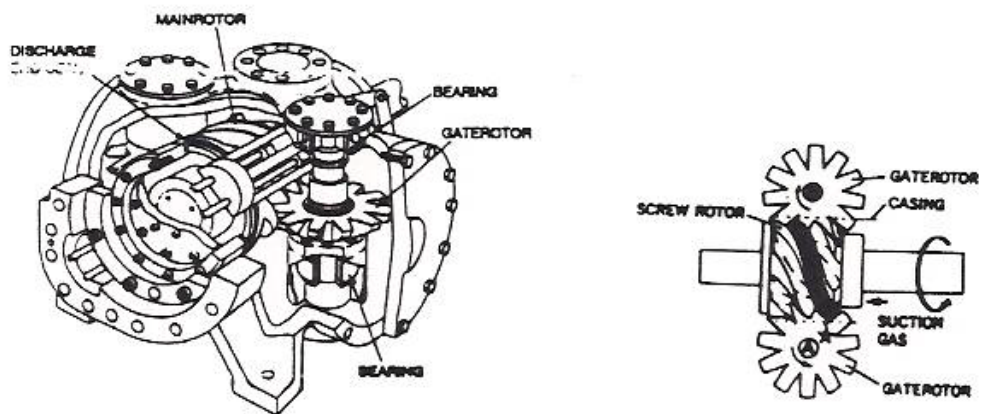

FIG. 6.3 Typical Single-Rotor Screw Construction

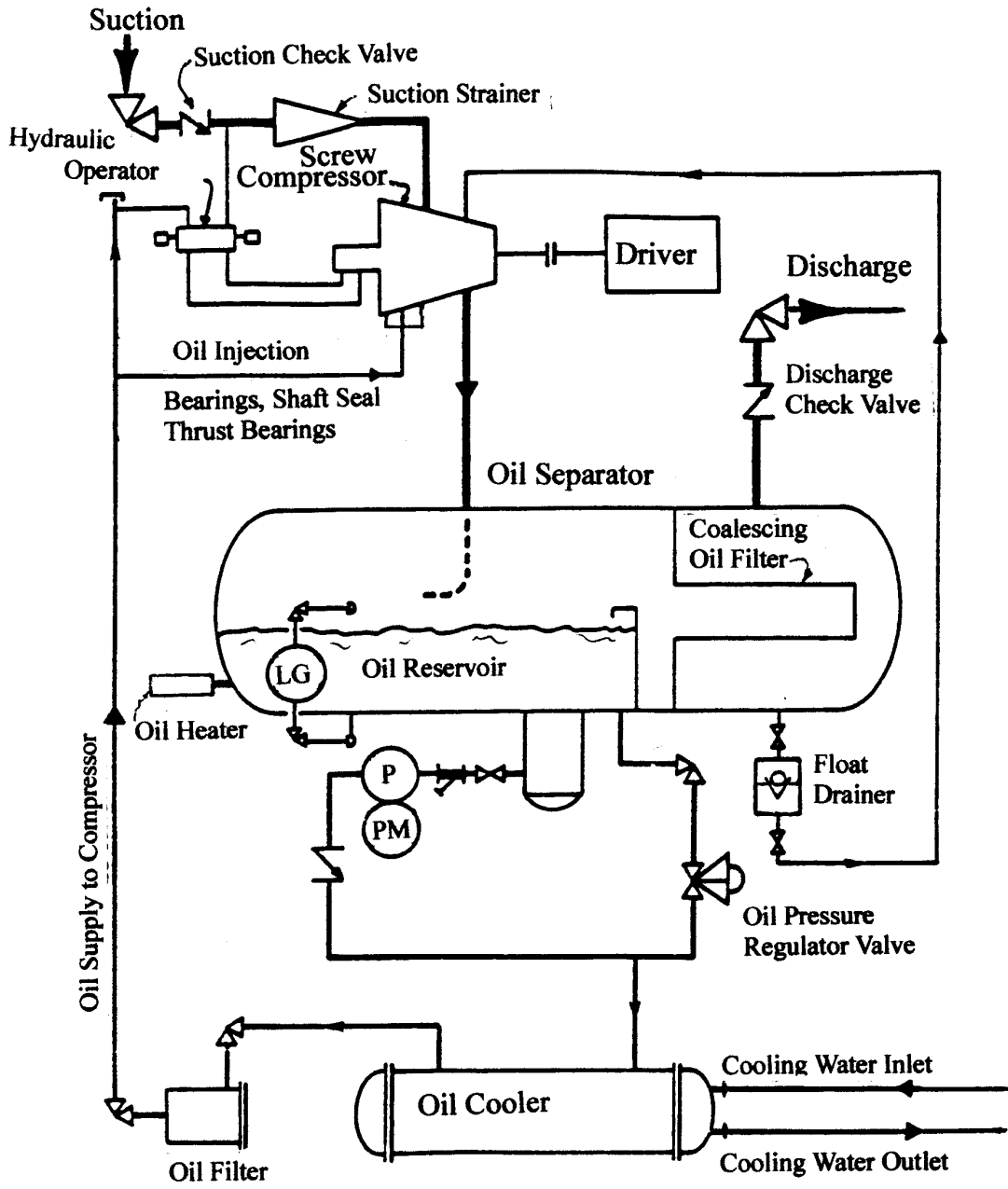

FIG. 6.4 Typical Screw Compressor Unit Arrangement

One of the terms that manufacturers commonly refer to is “Standard” such as “Standard Unit”. “Standard Unit” is the scope of supply for the unit as defined by the manufacturer. A Standard Unit for a screw compressor usually includes the components shown in FIG. 6.1, except the main driver. The standard steel base for the driver is designed to accept NEMA Standards motor and the unit is with single oil filter, single oil cooler and NEMA-1 control panel. Extra cost might be imposed by the maker for the items that is outside the scope of supply of the “Standard Unit”. Therefore, it is recommended to check what exactly the scope of supply is with each supplier.

The screw compressor used for industrial refrigeration is equipped with Hydraulic Operator and Slide Vane capacity control mechanism; the slide vane is capable of controlling the screw compressor for partial load operation down to 10% without surge. FIG. 6.5 is a typical partial load performance curve chart for a screw compressor.

The general compression ratio limit for screw compressor could be as high as 25:1. However, the compressor efficiency is lower when the compression ratio is higher.

Other technical, application details and special feature for the screw compressor are as the following:

Economizer:

One of the special features of screw compressor is to allow a side load connection to the compressor casing; this feature makes economizer cycle possible for the refrigeration system to improve the system efficiency. The capacity of the screw can be increased by using the economizer and yet the driving power increase is relatively small.

There are two types of economizer for the screw compressor; one is Flash Economizer and the other is the Liquid Subcooling Economizer. The economizer connection to the compressor casing is located by the compressor maker for the optimum pressure for the economizer. The benefit of economizing is better when the compression ratio of the compressor is higher.

Flash Type Economizer:

FIG. 6.6 shows the flash type economizer using a vertical type flash intercooler which is controlled by a liquid level valve. The flash gas returns to the side connection of the compressor. The FIG. 6.7 is also a flash intercooler, but it is with a high pressure float valve, the intercooling vessel serves as the combination of economizer and receiver. The P-H diagram is the same for both flash economizing and is shown in FIG. 6.8. At the top of the FIG. 6.8 shown the compression cycle without economizer; where the Refrigeration Effect δH is small. The Refrigeration Effect δH is greatly increased when economizer is used.

TYPICAL PART LOAD CURVES
R-717 OR R-22

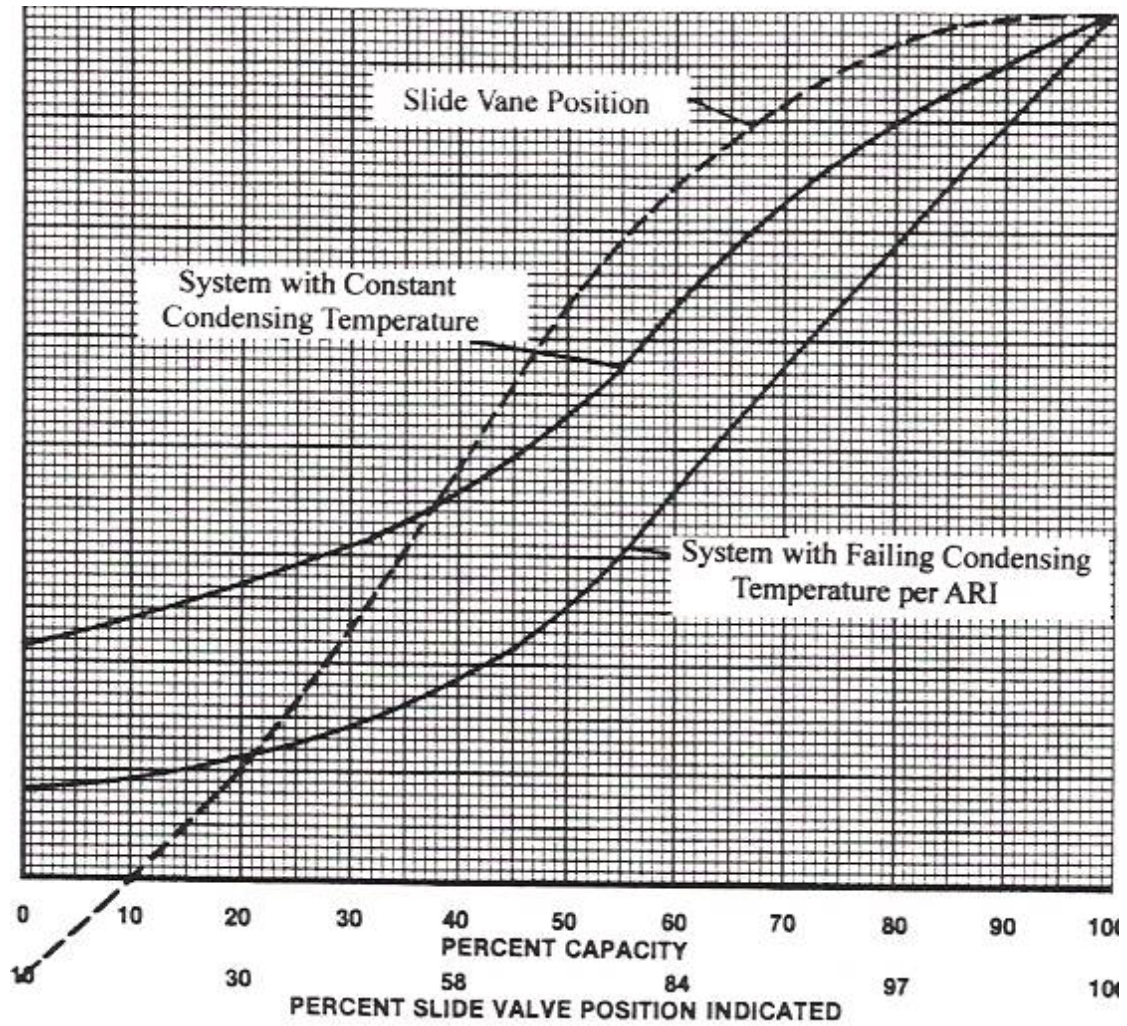

FIG. 6.5 Typical Partial Load Curves
Fixed Vi Screw Compressor

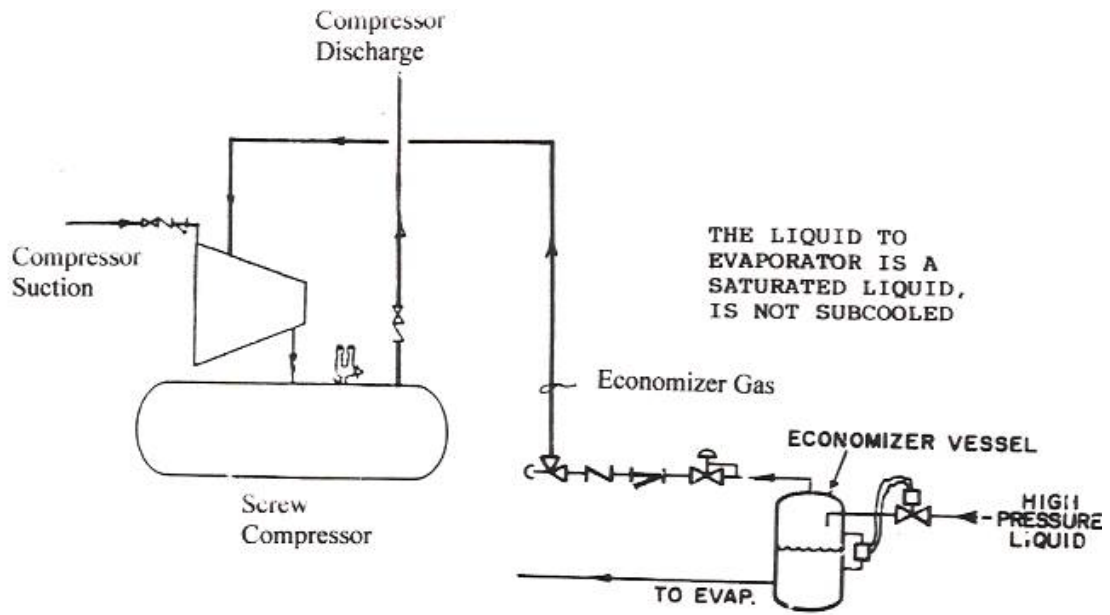

FIG. 6.6 Screw Compressor with Flash Economizer

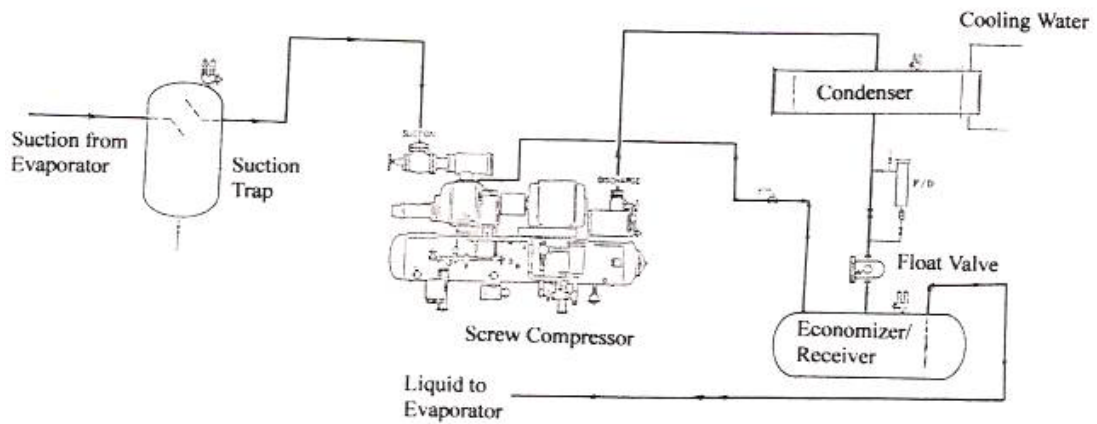

FIG. 6.7 Screw Compressor with Economizer/Receiver

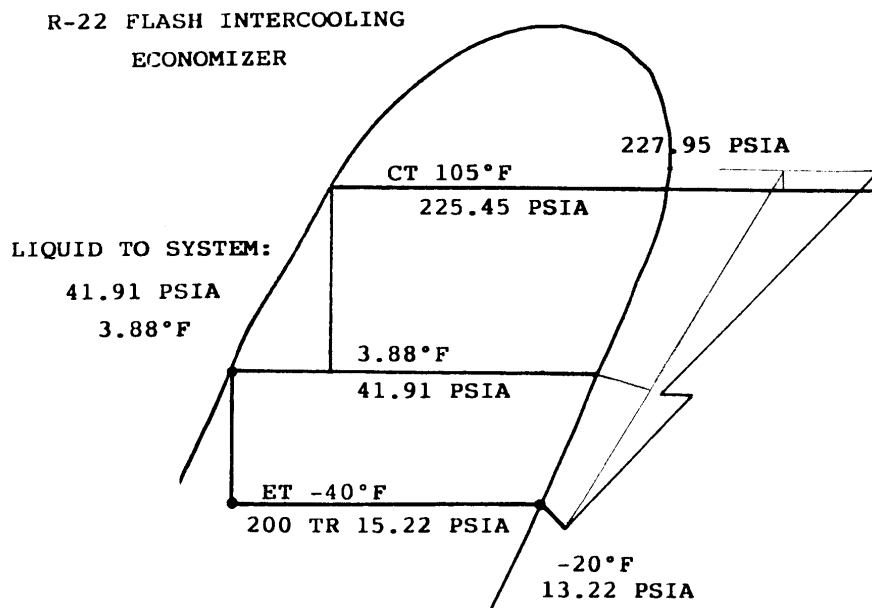
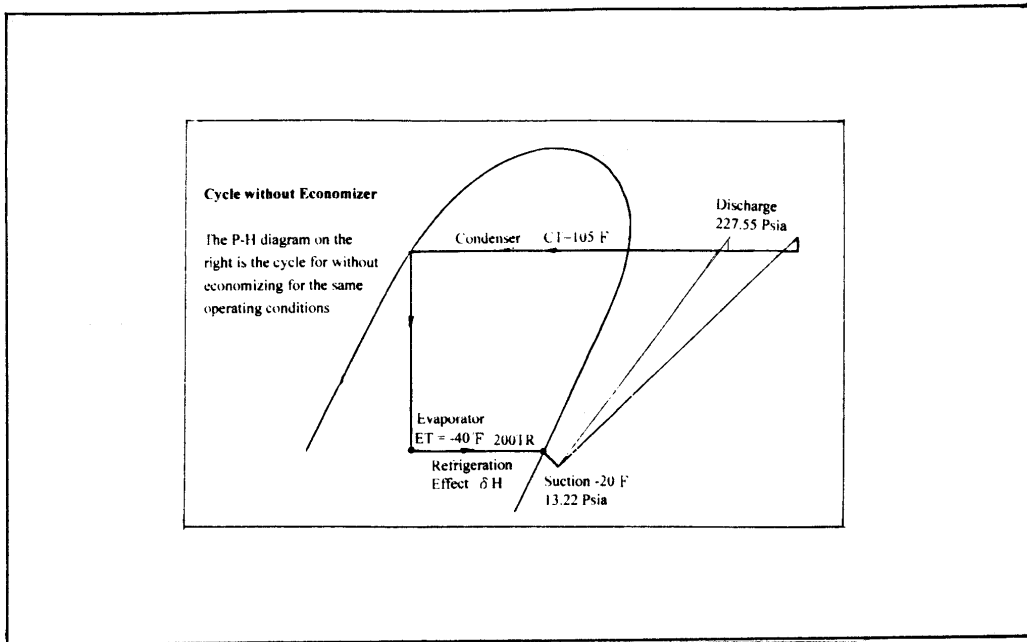

FIG. 6.8 P-H Diagram for Screw with Flash Economizer

Liquid Subcooling Type Economizer:

FIG. 6.9 shows the Shell-and-Coil type economizer in a vertical type intercooler which is controlled by a liquid level valve. The flash gas is returned to the side connection of the compressor. The FIG. 6.10 shown is a DX type liquid subcooling economizer. The P-H diagram for these two liquid subcooling (FIG. 6.9 and FIG. 6.10) is the same and it is shown in FIG. 6.11.

For the comparison, the P-H diagram shown at the top of the FIG. 6.11 is the compression cycle without economizer; the Refrigeration Effect δH is small. The Refrigeration Effect δH is greatly increased when liquid subcooling economizer is used.

Oil Pump:

The purpose of using oil pump is to supply oil injection for the rotors and shaft seal, to cool the compressor, to lubricate the bearings and for the hydraulic operator.

There are three types of compressor design when comes to the use of oil pump:

- 1) Some compressor design needs full time oil pump for the compressor operation.
- 2) Some compressor design only requires the oil pump to be operated for the start-up and shut-down. This type of oil pump is the auxiliary oil pump. The oil pump is not in operation after the compressor starts up.
- 3) Some compressor design can start up the compressor without the auxiliary oil pump and is able to utilize the system pressure differential from the oil reservoir to other parts of the compressor for the positive oil flow; no oil pump at all.

Oil pump is usually required if the system pressure differential is too small or when the compressor is used for booster duty or low stage application.

Oil Separator:

Oil injects into the screw compressor to lubricate the rotating parts and to cool the compressor. The oil absorbs a lot of heat; the oil vapor is mixed with the refrigerant gas when leave the compressor. The oil is to be removed as much as possible through an oil separator-filter before it goes to condenser and evaporator.

The oil separator is a standard component for the screw compressor for industrial refrigeration application. FIG. 6.12 is a typical three-stage oil separator structure for the screw compressor. The oil separator also serves as the oil reservoir. Most the oil separators of modern design screw compressors are equipped with Coalescent Filters inside of the oil separator for better oil separation efficiency. The oil carry over rate could be 3 PPM to 10 PPM depending on the operating conditions if Coalescent Filter is used.

Most Standard Units supplied by the manufacturers are with a horizontal oil separator as shown in FIG. 6.13. Vertical oil separator with floor mounted compressor might be required as special arrangement if the driving motor is too heavy or a special driver such gas engine, steam turbine or gas turbine is being used.

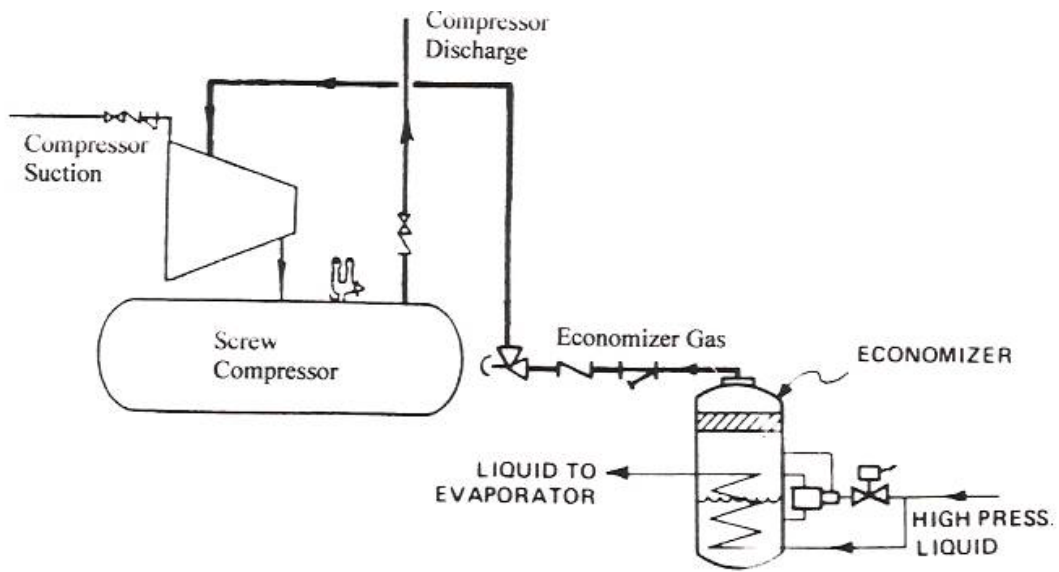

FIG. 6.9 Screw Compressor with Shell-and-Coil Liquid Subcooling Economizer

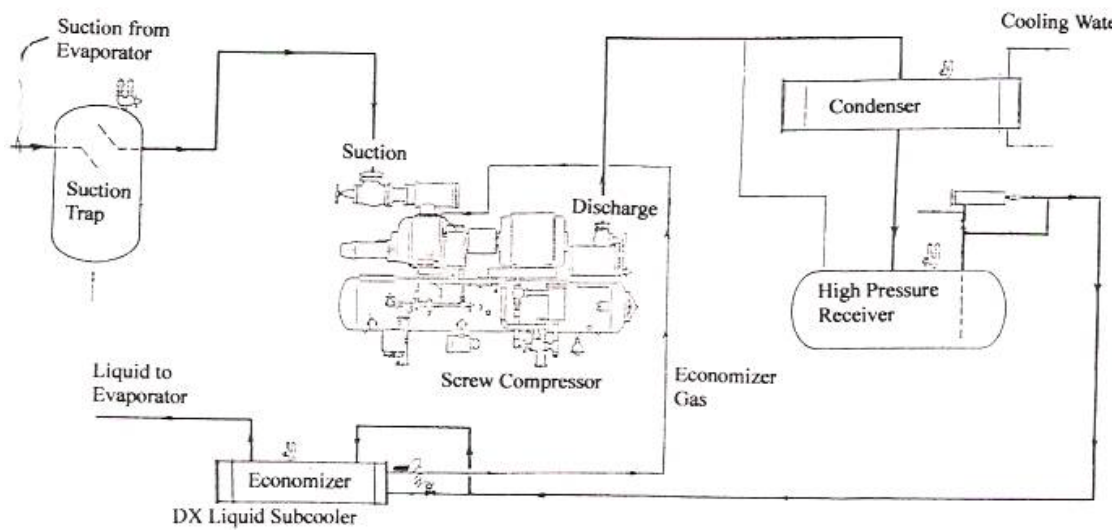
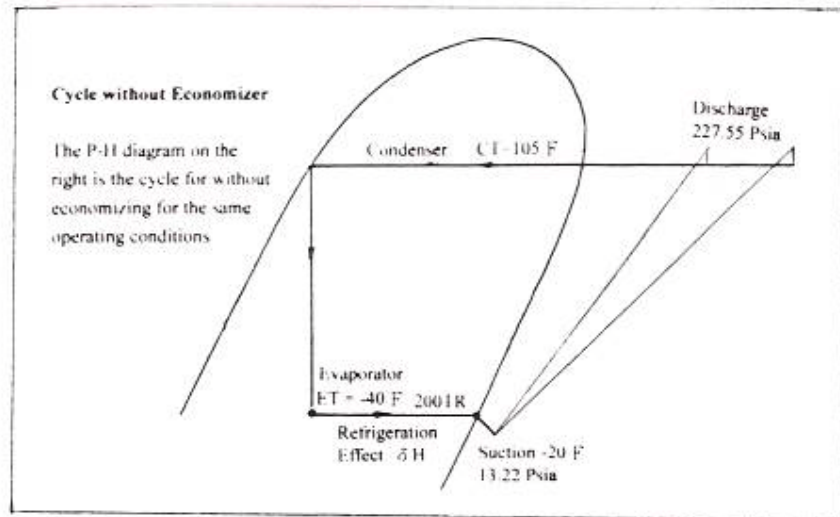

FIG. 6.10 Screw Compressor with DX Liquid Subcooling Economizer



R-22 LIQUID SUBCOOLING ECONOMIZER

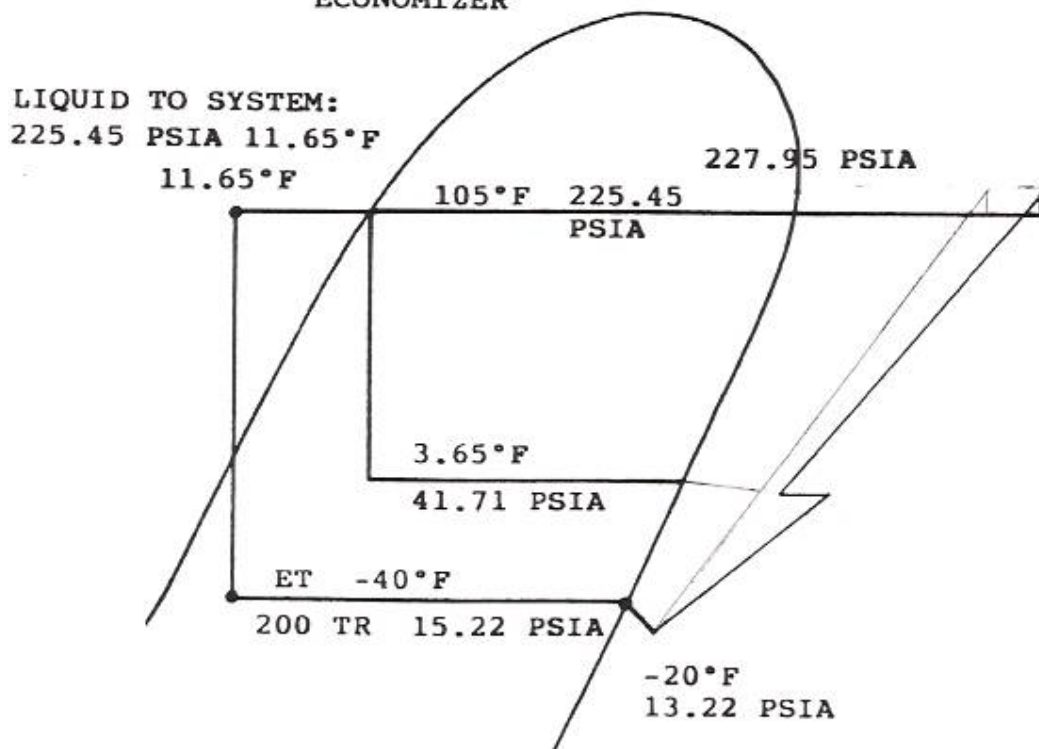

FIG. 6.11 P-H Diagram for Screw with Liquid Subcooling Economizer

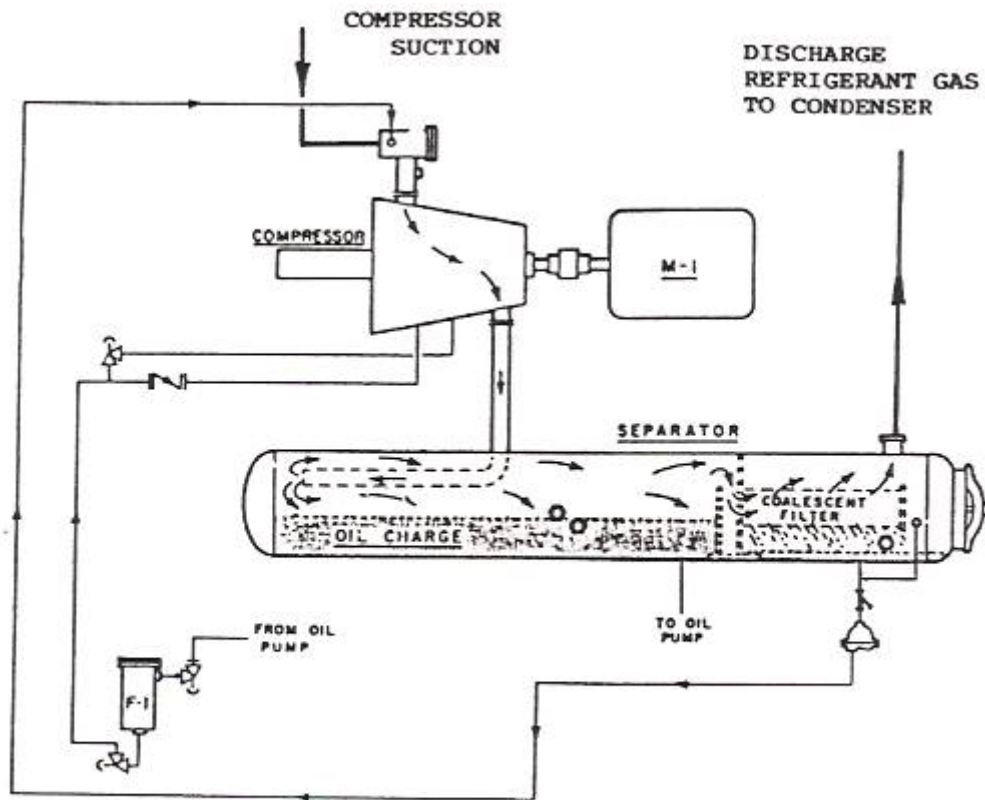

FIG. 6.12 Oil Separator – Screw Compressor Unit

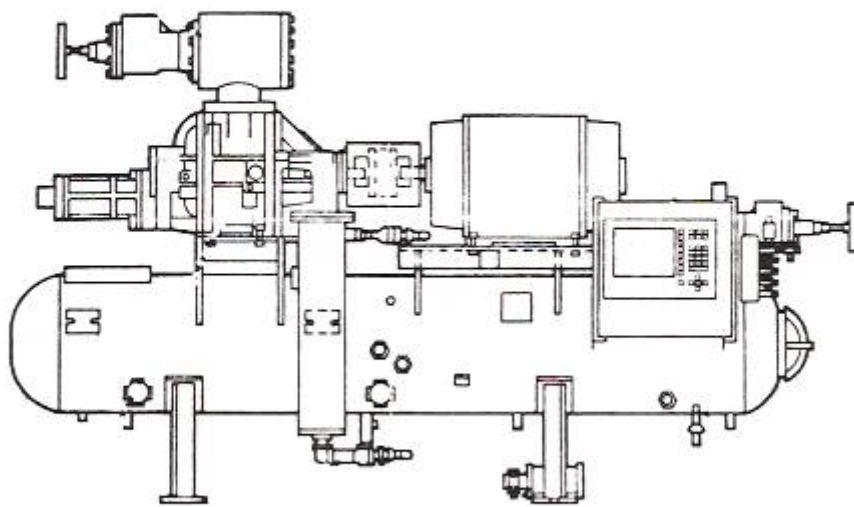

FIG. 6.13 Screw Unit with Horizontal Oil Separator

Oil Cooling & Oil Cooler:

The oil temperature in the oil separator is relatively high and therefore, it is to be cooled down by oil cooler (except the liquid injection oil cooling) to an acceptable temperature level before it is re-injected back to the compressor. There are several types of oil cooling methods available:

Water Cooled Oil Cooling:

Oil is cooled by water through a shell-and-tube heat exchanger as shown in FIG. 6.14. FIG. 6.15 shows the relative position between the oil cooler and the oil circuit of the screw compressor.

The major disadvantage of using water cooled oil cooler is that maintenance and service are required for the heat exchanger because of water problem. The big advantage is that a portion of the total heat rejection from the compressor is removed by water from the oil cooler to the cooling tower. The condenser heat rejection load is therefore smaller (see Heat Rejection for Condenser Selection).

Liquid Injection Oil Cooling:

Liquid injection oil cooling is that a small amount of refrigerant liquid from high pressure receiver is injected into the screw compressor just before the discharge port of the compressor. The liquid refrigerant evaporated and the mixture of the oil and the refrigerant vapor is cooled down to an acceptable temperature. This type of arrangement is shown in FIG. 6.16. The amount of liquid to be injected is control by a thermostatic expansion valve. The FIG. 6.17 shows the typical arrangement of a screw compressor with liquid injection oil cooling.

The advantage of using liquid injection oil cooling is low cost and very little maintenance is required. The disadvantages are capacity and power consumption penalties. It is generally about 7 to 9% in capacity reduction and also resulting in high power consumption rate. Sometimes, the liquid injection method might not be feasible for low head or high suction temperature applications.

Thermosyphon Oil Cooling:

Thermosyphone oil cooling is the method using refrigerant to cool the oil, but without penalizing the capacity or power consumption of the compressor.

FIG. 6.18 is the typical thermosyphone oil cooler arrangement. The thermosyphone oil cooler is a shell-and-tube heat exchanger. The oil flow through the shell side and refrigerant is through the tube side. The refrigerant liquid is supplied to the thermosyphone oil cooler from the thermosyphone receiver by gravity force. Portion of the liquid is vaporized to cool the oil in the heat exchanger; the bubbling mixture of liquid/vapor is circulated back to the thermosyphone receiver. The oil temperature returning to the compressor is regulated by a three-way thermostatic valve as indicated.

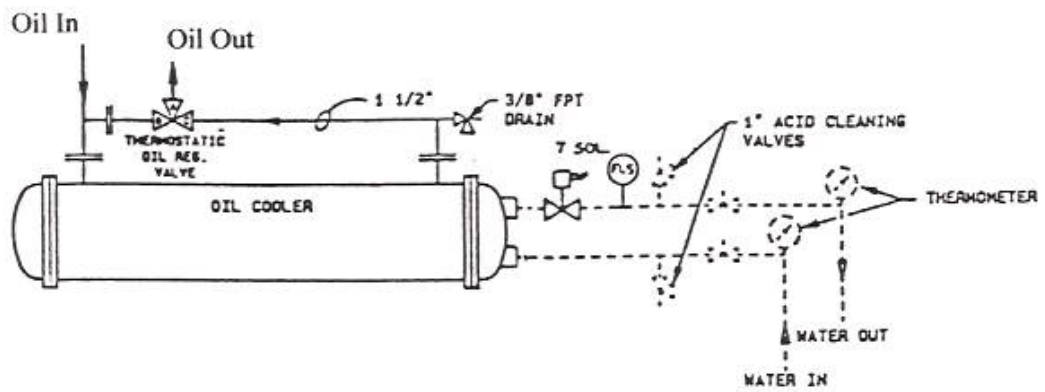

FIG. 6.14 Typical Water Cooled Oil Cooler

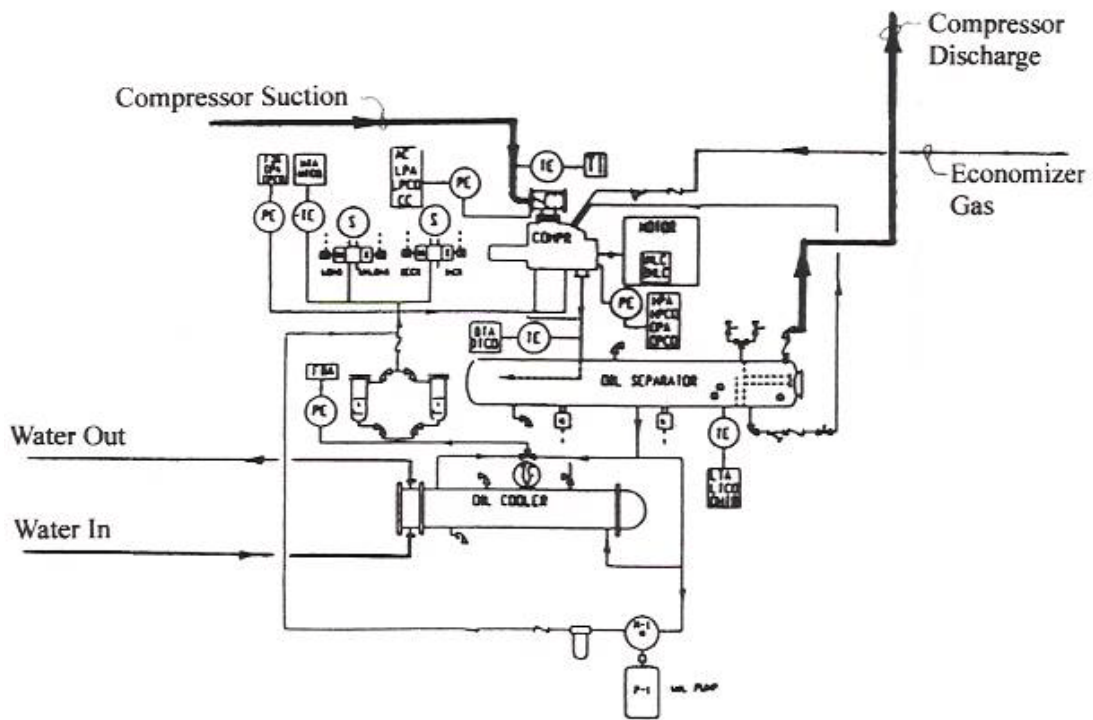

FIG. 6.15 Screw Compressor with Water Cooled Oil Cooler

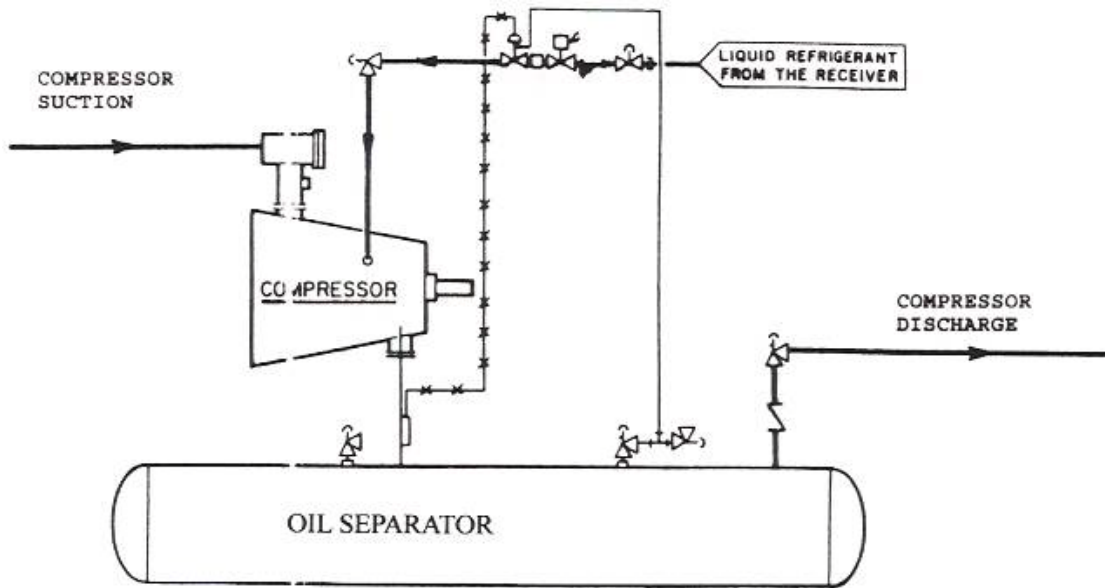

FIG. 6.16 Liquid Injection Oil Cooling

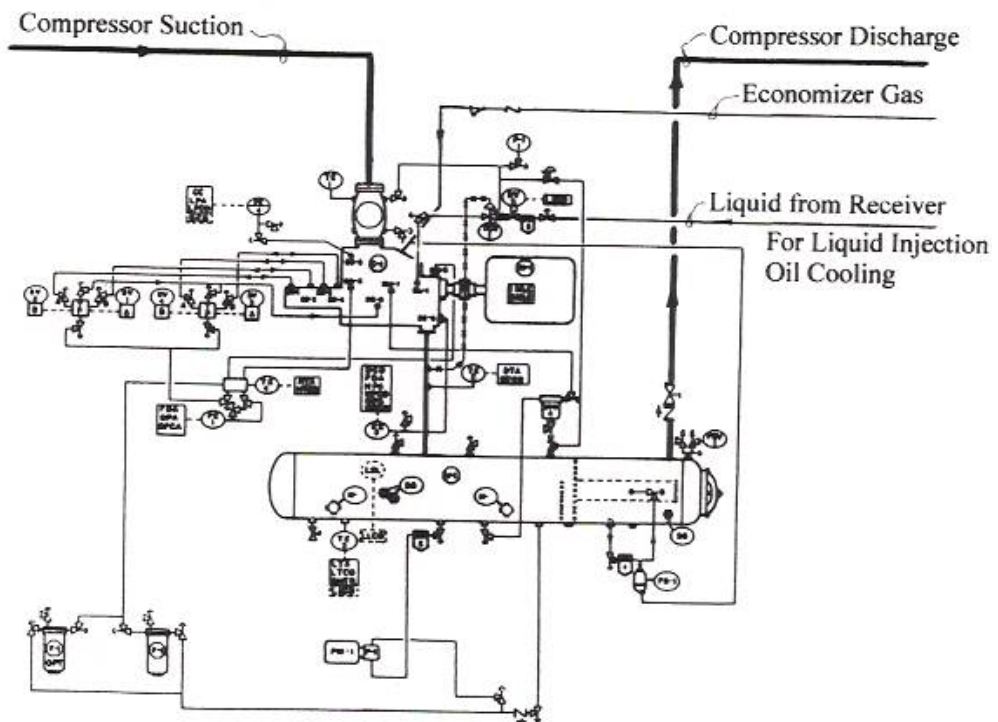

FIG. 6.17 Screw Compressor with Liquid Injection Oil Cooling

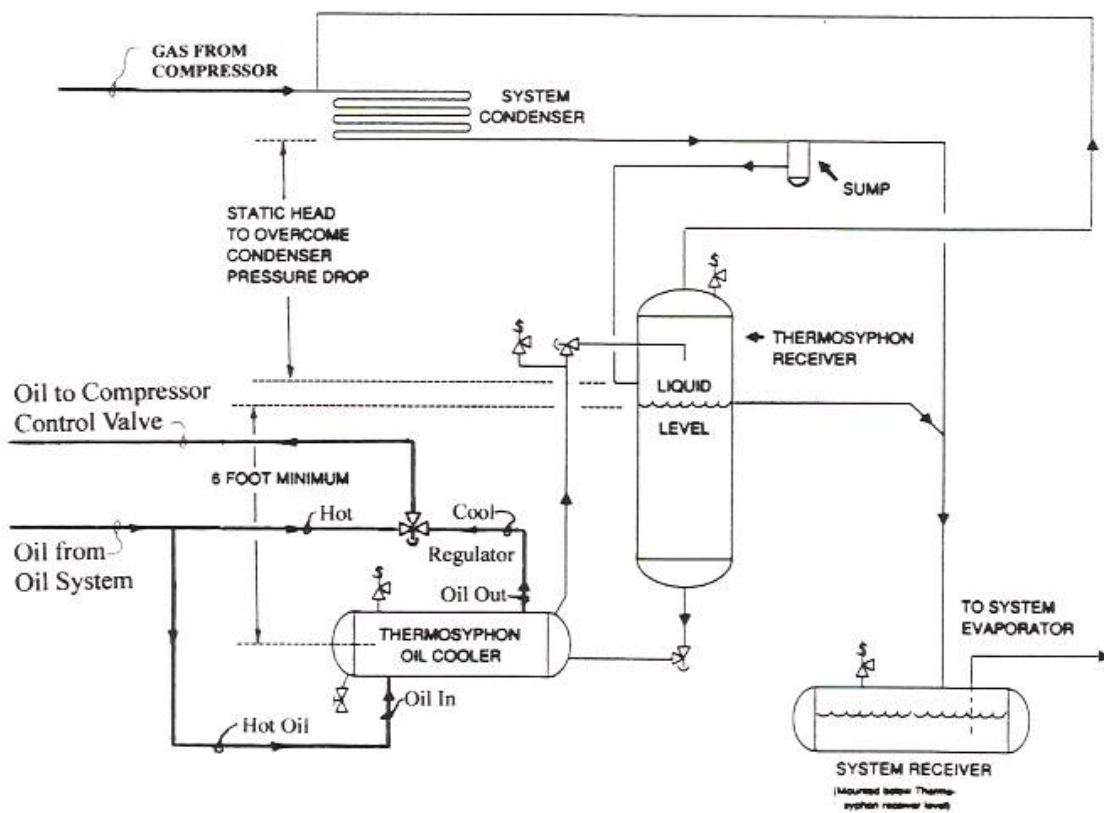
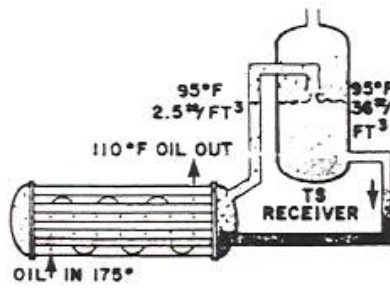

FIG. 6.18 Typical Thermosyphon Oil Cooler Arrangement

Dual Oil Coolers and Dual Oil Filters:

A lot of oil is circulated for the screw compressor. Oil flow is considered as the blood line for the screw compressor operation. For industrial process refrigeration application, the compressor is required to operate year round without being shut down. If it is the case, some of the users request that compressor unit is to be fitted with dual oil filters with a change over valve; this arrangement allows the switching of the oil flow to the stand-by filter while the other filter is being service and cleaned. Dual oil coolers with a change over valve also might be requested by the user for the same reason if water cooled oil cooler is used.

Capacity Control Slide Valve:

Slide Valve (Slide Vane) is the capacity control device for the screw compressor. This slide valve is able to control the capacity range of the screw compressor from 100% down to 10% without surge. The layout and construction of the Slide Vane for the screw are shown in FIG. 6.19. The operational functions of the sliding vane with corresponding P-V diagram explanations are shown in FIG. 6.20. Case-(1) of FIG. 6.20 is when the slide vane fully closed for full load operation; When the load reduces say to 80% as shown in Case-(2), the slide vane moves to the right by the controller to allow 20% of the gas bypass back to the suction; The slide valve is moving further to the right in Case-(3) to allow more gas to be bypassed to the suction if the load reduces further. The slide valve moves to the left to closed the bypass opening when the refrigeration load is increased.

Internal Volume Ratio Vi:

The characteristic of a screw compressor is determined by the "Internal Volume Ratio" (Vi) of the compressor and the Vi is related to the length of the slide vane. The theory to explain all of this character is as the following:

When the refrigerant gas is compressed by the screw compressor, the gas pressure is increased while its volume is reduced. The internal compression ratio which occurs in the compressor prior to discharge and the discharge pressure of the compressor are governed by the location of the discharge port. For a fixed Vi design compressor, the length of the sliding vane is fixed and the discharge port is tailored at the time when the compressor is manufactured.

The fixed (or the built-in) pressure ratio of the screw compressor is presented by the formulas as the following:

$$P_i = \frac{P_d}{P_s} \text{----- (1)}$$

P_i = Built-in pressure ratio.

P_d = Pressure of the gas just before discharge.

P_s = Pressure of the gas just before compression.

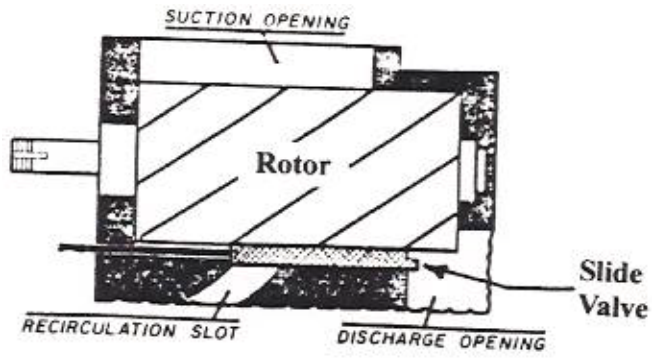

Screw Compressor Slide Valve

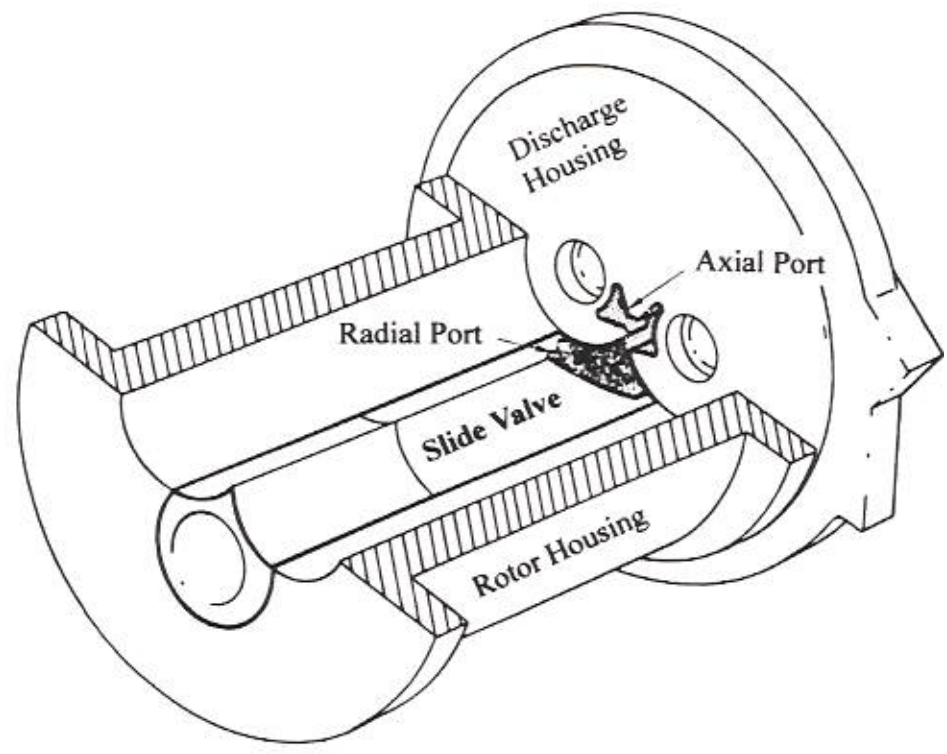

FIG. 6.19 Capacity Control Slide Valve Screw Compressor

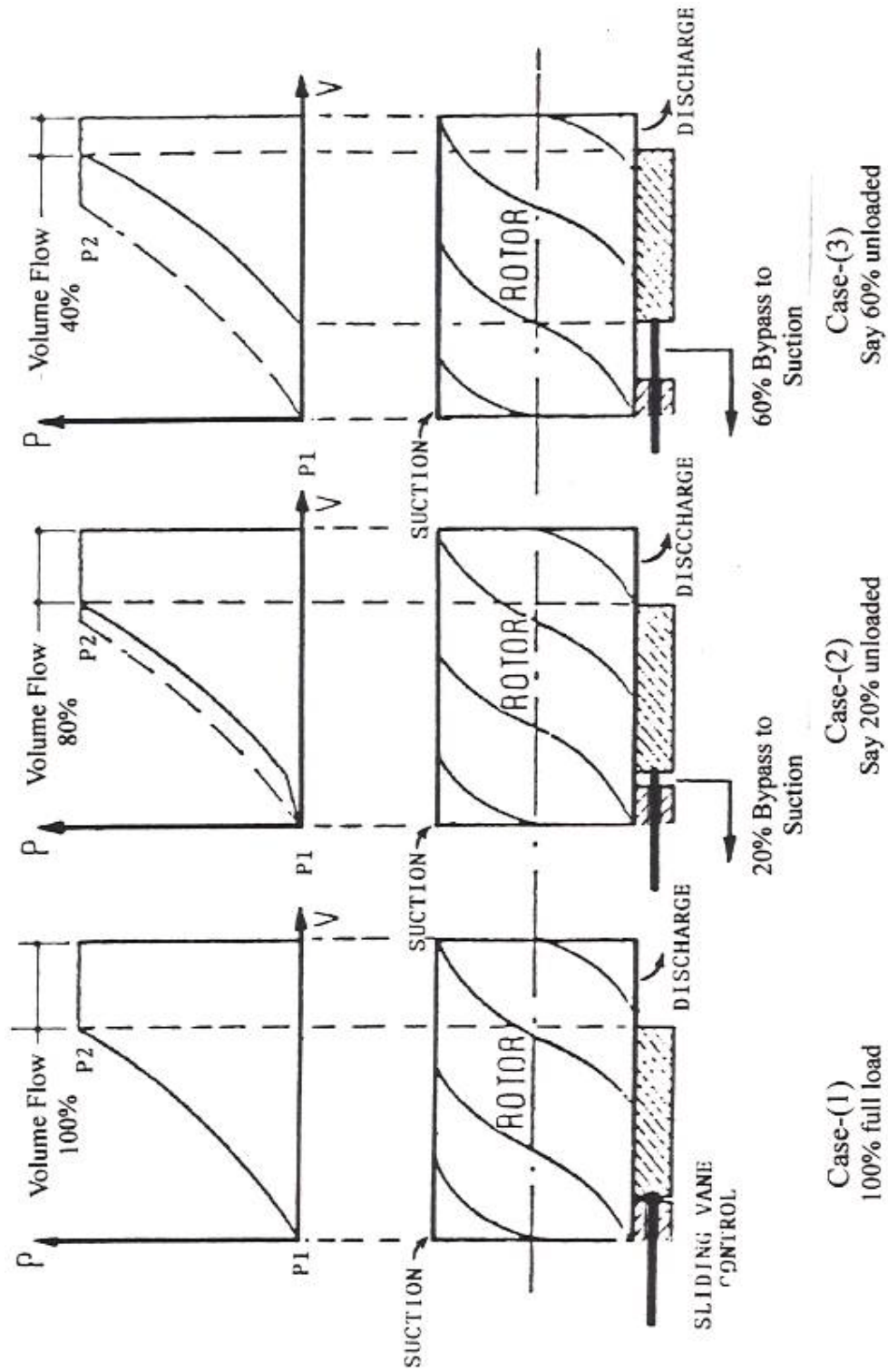

FIG. 6.20 Function of Sliding Valve Capacity Control

The term of "Built-in Volume Ratio (V_i)" is more frequently used than the built-in pressure ratio for the screw compressor. The V_i is defined as the following:

$$V_i = \frac{V_d}{V_s} \quad \text{-----} \quad (2)$$

V_i = Built-in volume ratio.

V_d = Volume of the gas just before discharge.

V_s = Volume of the gas just before compression.

From the Gas Law of thermodynamic, the built-in volume ratio is related to the built-in pressure ratio as the following:

$$P \times V^k = \text{Constant}$$

$$P_2 \times (V_2)^k = P_1 \times (V_1)^k \quad \text{-----} \quad (3)$$

k = Gas constant for the refrigerant being compressed.

or

$$P_d \times (V_d)^k = P_s \times (V_s)^k \quad \text{-----} \quad (4)$$

Therefore:

$$\frac{P_2}{P_1} = \frac{(V_1)^k}{(V_2)^k} \quad \text{-----} \quad (5)$$

$$\frac{P_d}{P_s} = \frac{(V_s)^k}{(V_d)^k} \quad \text{-----} \quad (6)$$

$$\frac{P_d}{P_s} = \left[\frac{V_s}{V_d} \right]^k \quad \text{-----} \quad (7)$$

$$\frac{P_d}{P_s} = V_i^k \quad \text{-----} \quad (8)$$

$$P_d = P_s \times (V_i)^k \quad \text{-----} \quad (9)$$

The selection of the size (length) of slide vane is in accordance with the design compression ratio for the compressor. See FIG. 6.21, a shorter slide vane is selected if the design compression ratio is small (low V_i), otherwise, a longer slide vane will be selected if the compression head is high (high V_i). The V_i is fixed once the length of the slide vane is selected for the compressor. The slide vane is selected at the time when the compressor is made in accordance with the design compression ratio.

The V_i becomes a constant once the slide vane length is given, this is referred to as a fixed V_i . From the formula (9), the characteristics of the screw compressor with this fixed V_i are as the following:

- (a) The discharge pressure of the compressor is always constant if the suction pressure is controlled at the set point for the refrigeration system.
- (b) The internal compression ratio of the screw compressor is always constant no matter how the external system pressure ratio changes. The internal pressure ratio of the compressor will not be able to match the external pressure ratio of the refrigeration system.
- (c) The screw compressor internal discharge pressure is not changed in despite of the pressure change in the condenser.

Both the adiabatic efficiency and the volumetric efficiency are fixed when the compressor is given a fixed V_i . A screw maker usually provides several sizes of slide vane available for the selection. For example, the sizes of slide vane to represent V_i of 2.33, 3.0, 3.6 and 4.6 are shown in FIG. 6.22. As indicated earlier, a low compression ratio uses a shorter sliding vane which is having a lower V_i and high compression ratio is logically to choose a longer sliding vane which is having a high V_i for better power consumption. Once a screw compressor is supplied with a specific built-in V_i , this V_i slide vane cannot be altered because it is determined by the geometrical shapes of the axial and radial outlet ports.

Once the compressor is supplied with a fixed V_i , for example $V_i = 3.0$, the compressor characteristic curve is fixed and the efficiency curve is following the curve "B" of the FIG. 6.22. The peak optimum efficiency of a screw compressor having V_i of 3.0 is at the compression ratio of 3.2. The compressor can be operated at any other compression ratio. However, the compressor shall operate at lower efficiency with higher power consumption.

Variable V_i Theory & Benefits:

As shown in (A) of FIG. 6.23, a fixed V_i screw compressor, the motion of the slid valve is stopped when it contacts with the rotor housing. In a variable V_i compressor, the slide vane is replaced with a second movable slide stop as shown in the (B) of FIG. 6.23. By moving the slides back and forth, the radial discharge port can be relocated during the operation to match compressor internal compression ratio to the external system pressure ratio to obtain optimum discharge pressure and maintaining the maximum efficiency.

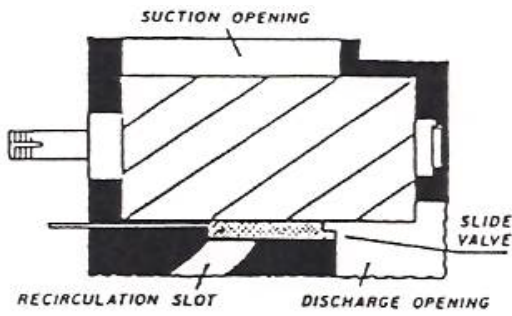

LOW FIXED V_i COMPRESSOR
Short Slide Valve

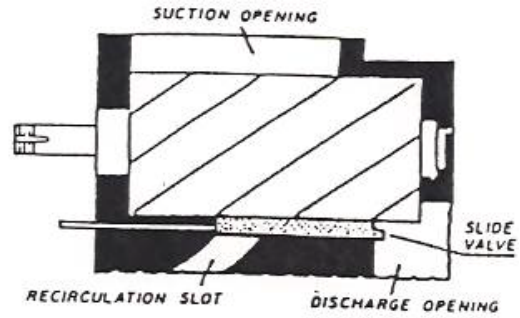

HIGH FIXED V_i COMPRESSOR
Long Slide Valve

View of Slide Valve from above

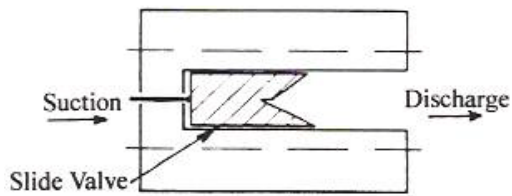

FIXED LOW V_i
Short Slide Valve

View of Slide Valve from above

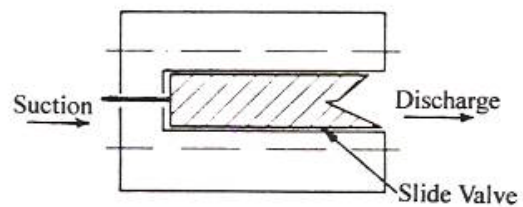

FIXED HIGH V_i
Long Slide Valve

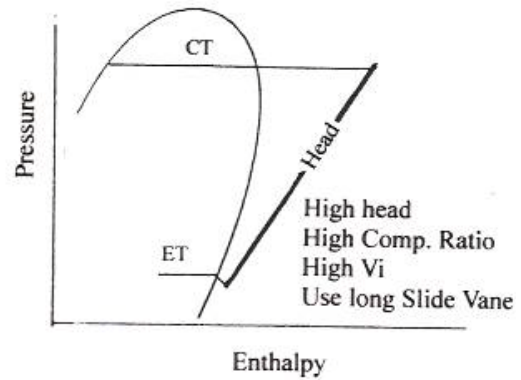
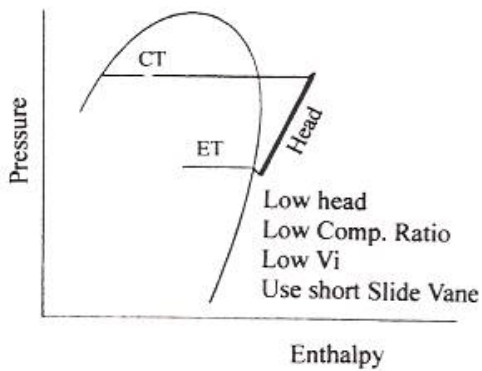

FIG. 6.21 Internal Volume Ratio (V_i) & Slide Vane

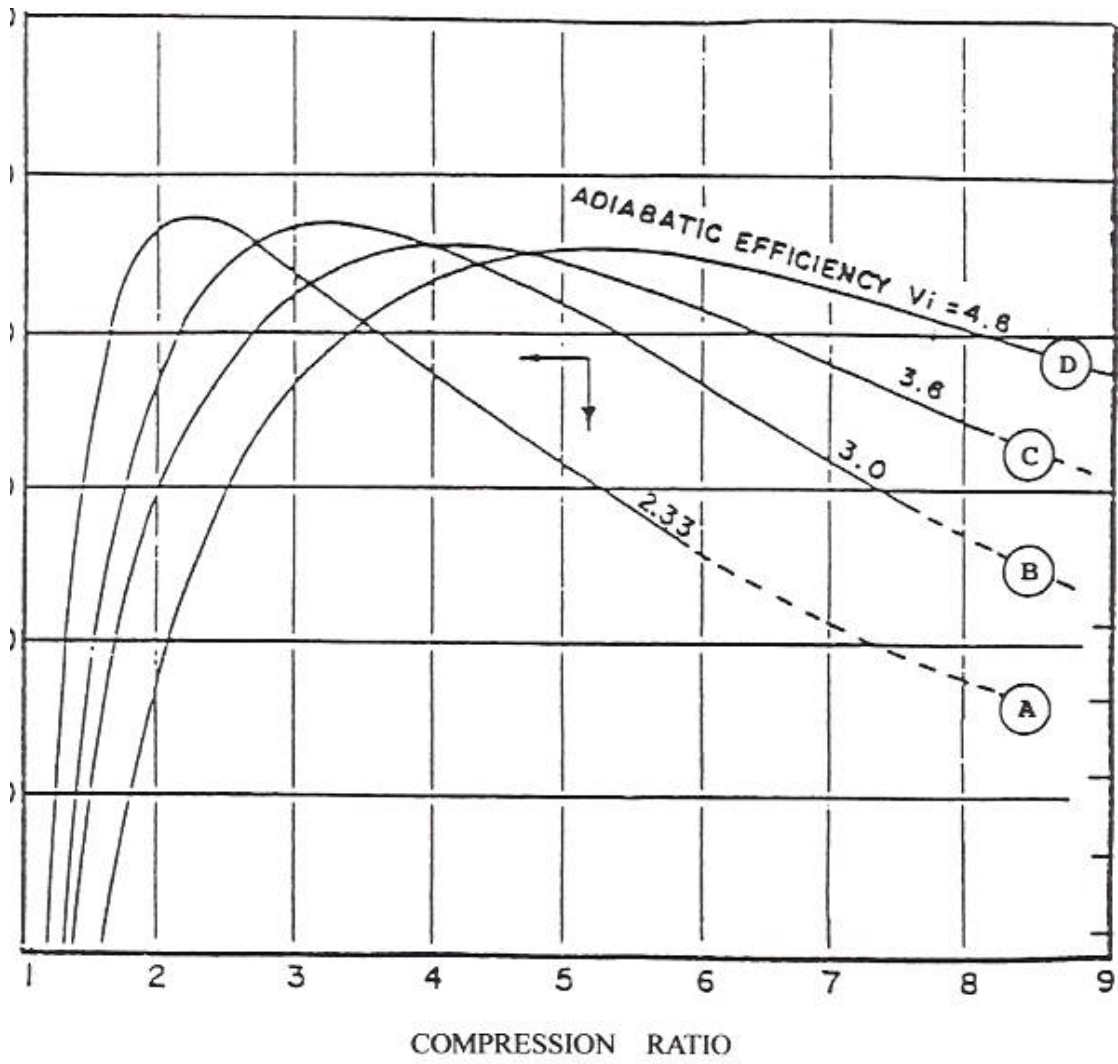

FIG. 6.22 Efficiency Curves for Fixed V_i Screw Compressor

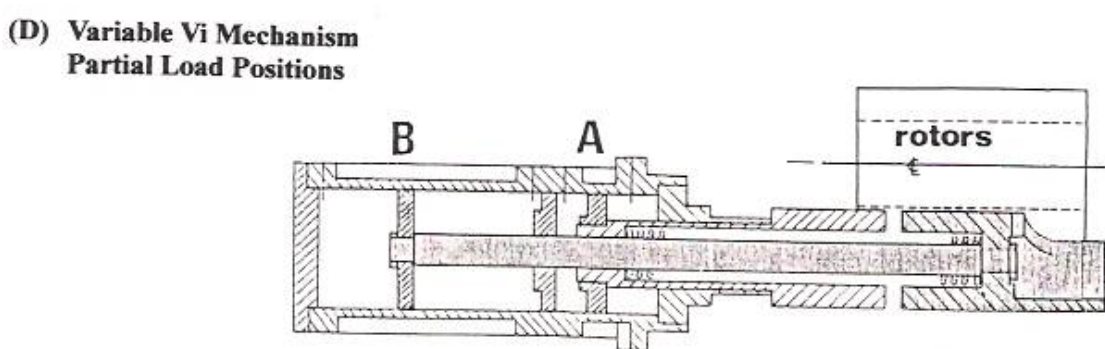
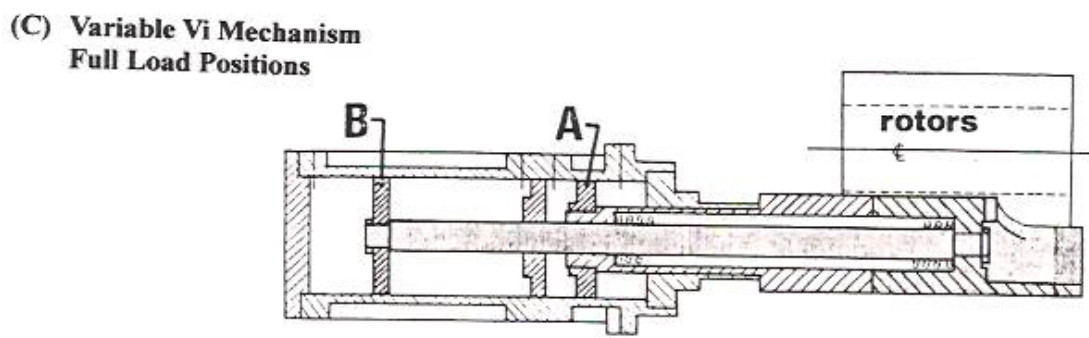
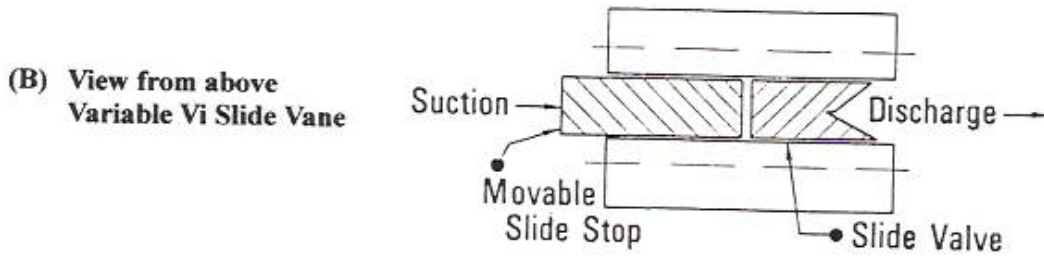
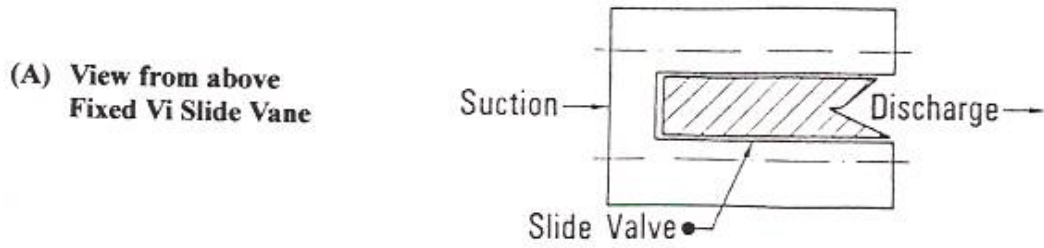

FIG. 6.23 Fixed Vi and Variable Vi Slide Vanes

A hydraulic controllers “A” and “B” are used to control the slide valve and slide stop separately as shown in FIG. 6.23(C). This allows the compressor V_i to be adjusted during operation and matching the compression discharge pressure precisely as required for the refrigeration system. The stepless control is automatically controlled by the microprocessor control panel for all the operational range and conditions. Thus, the maximum peak volumetric and adiabatic efficiencies of the compressor are maintained over all the operational ranges. Therefore, the efficiency curve of a variable V_i compressor is the line of (X)-(Y), which is at the top of the peak efficiencies of all fixed V_i curves as shown in FIG. 6.24. The power consumption of a variable V_i compressor is the best at all the partial load conditions. A variable V_i compressor is able to take the advantages of both reduce capacity and reduce head during any partial load operation; also the percent of partial load efficiency is actually increased. There, the annual power consumption evaluation is improved in accordance with the formula shown in FIG. 4-4.

Heat Rejection for Condenser Selection:

Normally, the heat rejection from a compressor to condenser is the sum of heat absorbed from the evaporator plus the heat input from driver. But, the amount of heat rejection to condenser from a screw compressor, it depends on what type of oil cooling system is used. For liquid injection and thermosyphone oil cooling system, the heat rejection to condenser from the screw compressor shall be the same as for reciprocating or centrifugal compressors. But, if the oil cooling method is water cooled oil cooler, the heat rejection to the condenser for the condenser selection shall be as the following:

Heat rejection for condenser selection, Btu/Hr:

$$= TR \times 12000 + BHP \times 2545 - [\text{Heat removal by water cooled oil cooler}]$$

Where TR: Tons of Refrigeration
 BHP: Horse power input to the compressor

Control Panel:

Most standard unit is with a computer type microprocessor control panel with display and keyboard. It provides automatic control for the continuous operation of the unit or even the refrigeration system; to control slide vane to maintain suction pressure or temperature at a set point; to control the variable V_i for the maximum efficiency. The control panel also can provide self-diagnoses and self-check constantly and continuously against the pre-set safety operation set points of the unit. The control panel can communicate with a building automation system. Most panels are with NEMA-1 enclosure as standard from most makers in the world. But, it can be specially modified to suit any electrical code requirement.

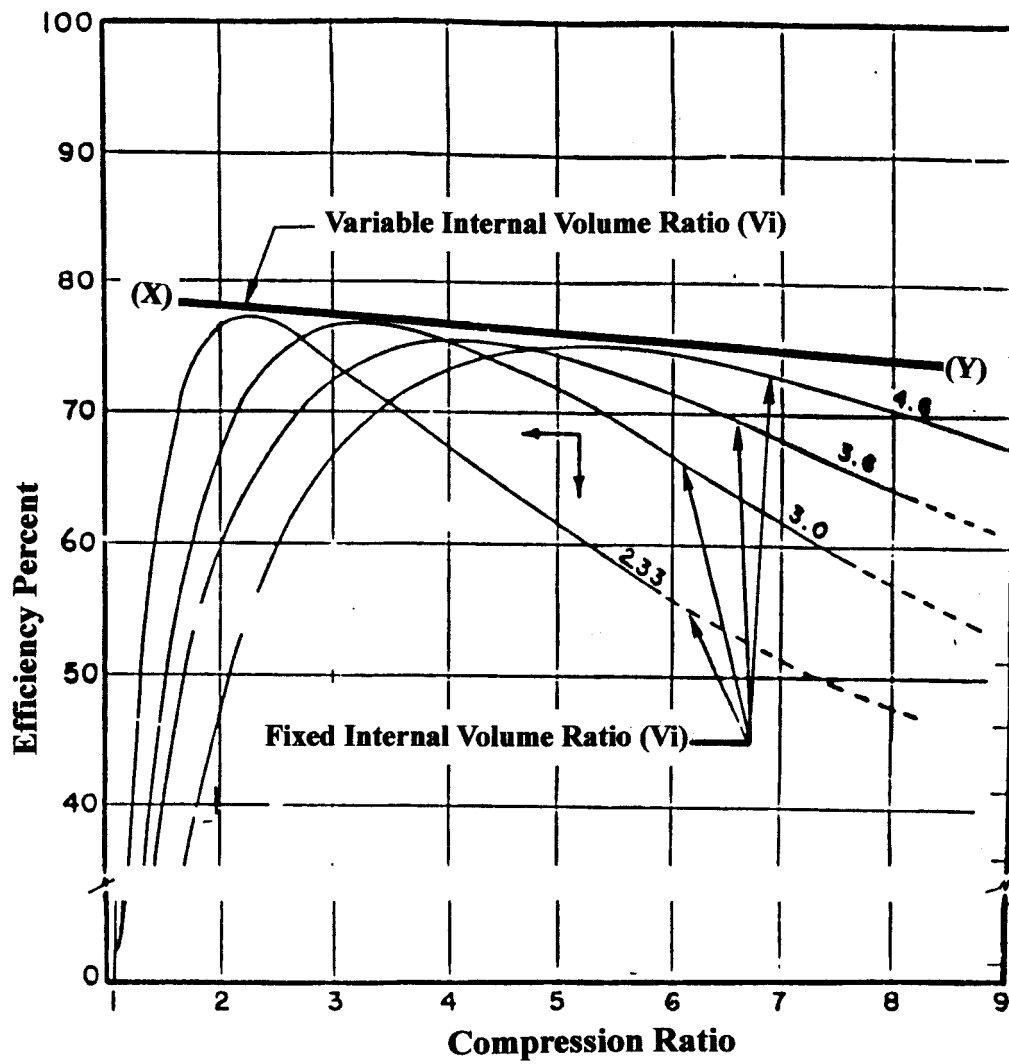

**FIG. 6.24 Efficiency Comparison & Improvement
Fixed Vi vs Variable Vi
Screw Compressor**