

Chapter 7

FLOW THROUGH PIPES

7-1 Friction Losses of Head in Pipes
7-3 Flow through Pipe Systems

7-2 Secondary Losses of Head in Pipes

48

7-1 Friction Losses of Head in Pipes:

There are many types of losses of head for flowing liquids such as friction, inlet and outlet losses. The major loss is that due to frictional resistance of the pipe, which depends on the inside roughness of the pipe. The common formula for calculating the loss of head due to friction is Darcy's one.

Darcy's formula for friction loss of head:

For a flowing liquid, water in general, through a pipe, the horizontal forces on water between two sections (1) and (2) are:

$$P_1 A = P_2 A + F_R$$

P_1 = Pressure intensity at (1).

A = Cross sectional area of pipe.

P_2 = Pressure intensity at (2).

F_R = Frictional Resistance at (2).

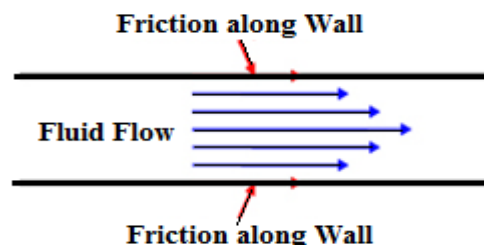
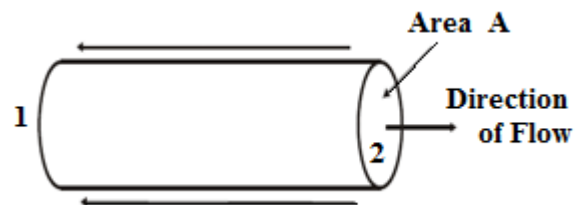

$$F_R / \gamma A = (P_1 / \gamma) - (P_2 / \gamma) = h_f$$

Where, h_f = Loss of pressure head due to friction.

γ = Specific gravity of water.

It is found experimentally that:

$$F_R = \text{Factor} \times \text{Wetted Area} \times \text{Velocity}^2$$

$$F_R = (\gamma f / 2g) \times (\pi d L) \times v^2$$

Where, f = Friction coefficient.

d = Diameter of pipe.

L = Length of pipe.

49

$$h_f = \frac{(\gamma f / 2g) \times (\pi d L) \times v^2}{\gamma (\pi d^2 / 4)} = \frac{4 f * L * v^2}{d * 2 g}$$

$$h_f = \frac{4 f L v^2}{2 g d}$$

It may be substituted for $[v = Q / (\pi d^2 / 4)]$ in the last equation to get the head loss for a known discharge. Thus,

$$h_f = \frac{32 f L Q^2}{\pi^2 g d^5}$$

Note: In American practice and references, $\lambda = f_{\text{American}} = 4 f$

Example 1:

A pipe 1 m diameter and 15 km long transmits water of velocity of 1 m/sec. The friction coefficient of pipe is 0.005.

Calculate the head loss due to friction?

Solution

$$h_f = \frac{4 f L v^2}{2 g d}$$

$$h_f = \frac{4 \times 0.005 \times 15000 \times 1^2}{2 \times 9.81 \times 1} = 15.29 \text{ m}$$

The Darcy – Weisbach equation relates the head loss (or pressure loss) due to friction along a given length of a pipe to the average velocity of the fluid flow for an incompressible fluid.

The friction coefficient f (or $\lambda = 4 f$) is not a constant and depends on the parameters of the pipe and the velocity of the fluid flow, but it is known to high accuracy within certain flow regimes.

For given conditions, it may be evaluated using various empirical or theoretical relations, or it may be obtained from published charts.

R_e (Reynolds Number) is a dimensionless number.

$$R_e = \frac{\rho v d}{\mu}$$

<u>For pipes,</u>	Laminar flow,	$R_e < 2000$
	Transitional flow,	$2000 < R_e < 4000$
	Turbulent flow,	$R_e > 4000$

For laminar flow,

Poiseuille law, ($f = 64/R_e$) where R_e is the Reynolds number .

For turbulent flow,

Methods for finding the friction coefficient f include using a diagram such as the Moody chart, or solving equations such as the Colebrook–White equation.

Also, a variety of empirical equations valid only for certain flow regimes such as the Hazen – Williams equation, which is significantly easier to use in calculations. However, the generality of Darcy – Weisbach equation has made it the preferred one.

The only difference of (h_f) between laminar and turbulent flows is the empirical value of (f).

Introducing the concept of smooth and rough pipes, as shown in Moody chart, we find:

- 1) For laminar flow, $f = 16 / R_e$
- 2) For transitional flow, pipes' flow lies outside this region.
- 3) For smooth turbulent (a limiting line of turbulent flow), all values of relative roughness (k_s/d) tend toward this line as R decreases. Blasius equation: $f = 0.079 / R_e^{0.25}$
- 4) For transitional turbulent, it is the region where (f) varies with both (k_s/d) & (R_e). Most pipes lie in this region.
- 5) For rough turbulent, (f) is constant for given (k_s/d) and is independent of (R_e).

Doing a large number of experiments for the turbulent region for commercial pipes, Colebrook-White established the equation:

$$\frac{1}{\sqrt{f}} = -4 \log_{10} \left(\frac{k_s}{3.71d} + \frac{1.26}{Re \sqrt{f}} \right)$$

This equation is easily solved employing Moody chart.

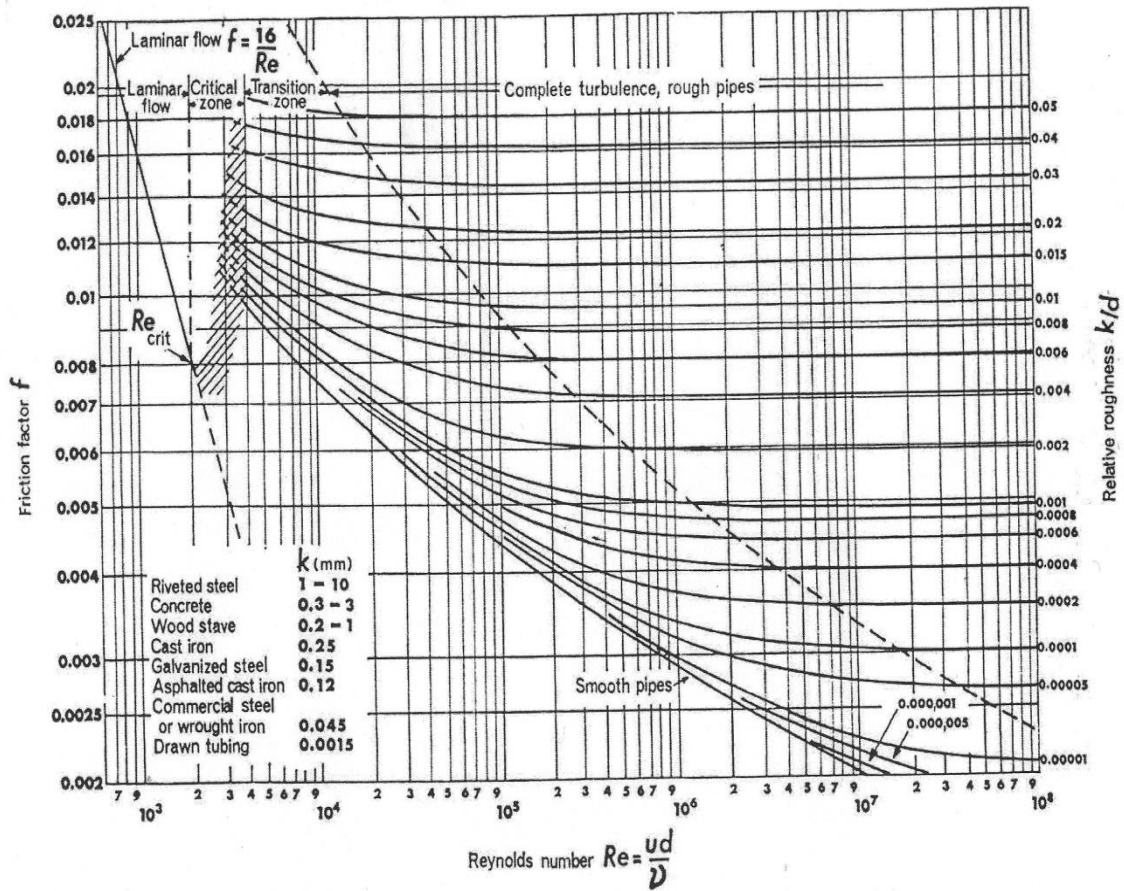

Moody Chart

$\lambda = 4 f$ & values of k_s are provided by pipe manufactures.

Pipe Material	K, mm
Brass, Copper, Glass	0.003
Asbestos Cement	0.03
Iron	0.06
Galvanised Iron	0.15
Plastic	0.03
Bitumen-lined Ductile Iron	0.03
Concrete-lined Ductile Iron	0.03

Example 2:

Water flows in a steel pipe ($d = 40 \text{ mm}$, $k = 0.045 \times 10^{-3} \text{ m}$, $\mu = 0.001 \text{ k/ms}$) with a rate of 1 lit/s.

53

Determine the friction coefficient and the head loss due to friction per meter length of the pipe using:

- 1- Moody chart? 2- Smooth pipe formula?

Solution

$$v = Q / A = 0.001 / (\pi (0.04)^2 / 4) = 0.796 \text{ m/s}$$

$$Re = \rho v d / \mu = (1000 \times 0.796 \times 0.04) / 0.001 = 31840 > 4000$$

∴ Turbulent flow.

1. Moody chart:

$$k/d = 0.045 \times 10^{-3} / 0.04 = 0.0011 \quad \& \quad Re = 31840$$

∴ from the chart, $f = 0.0065$

$$h_f = \frac{4 f L v^2}{2 g d} = \frac{4 \times 0.0065 \times 1 \times (0.796)^2}{2 \times 9.81 \times 0.04} = 0.0209 \text{ m / m of pipe}$$

2. Smooth pipe (Blasius equation):

$$f = 0.079 / Re^{0.25} = 0.079 / (31840) = 0.0059$$

$$h_f = \frac{4 f L v^2}{2 g d} = \frac{4 \times 0.0059 \times 1 \times (0.796)^2}{2 \times 9.81 \times 0.04} = 0.02 \text{ m / m of pipe}$$

Another Solution:**Moody Friction Factor Calculator**

Calculation uses an equation that simulates the Moody Diagram. Turbulent or laminar flow.

Moody friction factor calculation is mobile-device-friendly as of January 29, 2014

54

Select Calculation:

- Circular Duct: Enter D and Q
- Circular Duct: Enter D and V
- Circular Duct: Enter D and Re
- Non-circular Duct: Enter A, P, and Q
- Non-circular Duct: Enter A, P, and V
- Non-circular Duct: Enter A, P, and Re

© 2014 LMNO Engineering,
Research, and Software, Ltd.
<http://www.LMNOeng.com>

Initial Values

Click to Calculate

Kinematic viscosity, ν (L ² /T):	1.0E-6
Surface Roughness, e (L):	4.5E-5
Duct Diameter, D (L):	0.04
Duct Area, A (L ²):	0.0012566371
Duct Perimeter, P (L):	0.12566371
Velocity, V (L/T):	0.79577472
Discharge, Q (L ³ /T):	0.001
Reynolds Number:	31830.989
e/D :	0.001125
Moody Friction Factor, f :	0.026171935

$$f = \frac{64}{Re} \text{ for } Re \leq 2100 \text{ (laminar flow)} \quad Re = \frac{VD}{\nu}$$

$$f = \frac{1.325}{\left[\ln \left(\frac{e}{3.7D} + \frac{5.74}{Re^{0.9}} \right) \right]^2} \text{ for } 5000 \leq Re \leq 10^8 \text{ (turbulent flow) and } 10^{-6} \leq \frac{e}{D} \leq 10^{-2}$$

D = Diameter of a circular duct. If duct is non-circular, then D is computed as the hydraulic diameter of a rectangular duct, where $D = 4A / P$ per our [non-circular duct page](#).
 Re = Reynolds Number. The symbol Re is not the product $(R)(e)$.

[Kinematic viscosity \(\$\nu\$ \) depends on the fluid \(water, air, etc.\). Click for table.](#)

[Surface roughness depends on the duct material \(steel, plastic, iron, etc.\). Click for table.](#)

The equations used in this program represent the Moody diagram which is the old-fashioned way of finding f . You may enter numbers in any units, so long as you are consistent. (L) means that the variable has units of length (e.g. meters). (L³/T) means that the variable has units of cubic length per time (e.g. m³/s). The Moody friction factor (f) is used in the [Darcy-Weisbach major loss equation](#). Note that for laminar flow, f is independent of e . However, you must still enter an e for the program to run even though e is not used to compute f . Equations can be found in [Discussion and References for Closed Conduit Flow](#).

A more complicated equation which represents a slightly larger range of Reynolds numbers and e/D 's is used in [Design of Circular Liquid or Gas Pipes](#).

© 1999-2014 LMNO Engineering, Research, and Software, Ltd. All rights reserved.

LMNO Engineering, Research, and Software, Ltd.
7860 Angel Ridge Rd. Athens, Ohio 45701 USA Phone and fax: (740) 592-1890
LMNO@LMNOeng.com <http://www.LMNOeng.com>

August 25, 2015: Made text fields show 8 significant figures rather than 16. Calculation still uses double precision internally.

Example 3:

The pipe of a syphon has 75 mm diameter and discharges water to the atmosphere, as shown in figure.

Neglect all possible losses.

- Determine the velocity of flow?
- Find the discharge?
- What is the absolute pressure at the point 2?

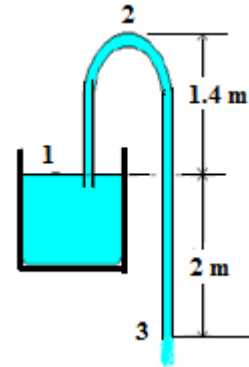

55

Solution

- (a) Applying Bernoulli's equation between (1) and (3),

$$2 + 0 + 0 = 0 + 0 + (v_3^2/2g)$$

$$v_3 = 6.26 \text{ m/s}$$

- (b) $Q = v_3 \times A = 6.26 \times (\pi (0.075)^2/4) = 0.028 \text{ m}^3/\text{s}$

- (c) Applying Bernoulli's equation between (1) and (2),

$$2 + 0 + 0 = 3.4 + P_2/\rho g + (6.26^2/2g)$$

$$P_2 = - 3.397 \times (1000 \times 9.81) = - 33327.8 \text{ N/m}^2 = - 33.33 \text{ kPa}$$

$$P_{2\text{abs}} = 64.77 \text{ kPa} \quad \text{where, } (P_{\text{atm}} = 98.1 \text{ kN/m}^2)$$

7-2 Secondary Losses of Head in Pipes:

Any change in a pipe (in direction, in diameter, having a valve or other fitting) will cause a loss of energy due to the disturbance in the flow.

$$h_s = K (v^2 / 2g)$$

The velocity v is the velocity at the entry to the fitting. When the velocity changes upstream and downstream the section, the larger velocity is generally used.

Obstruction	K
Tank Exit	0.5
Tank Entry	1.0
Smooth Bend	0.3
90° Elbow	0.9
45° Elbow	0.4
Standard T	1.8
Strainer	2.0
Angle Valve, wide open	5.0
<u>Gate Valve:</u>	0.2
Wide Open	
3/4 open	1.2
1/2 open	5.6
1/4 open	24.0
Sudden Enlargement	0.1
<u>Sudden Contraction:</u>	
Area Ratio (A_2/A_1) = 0.2	0.4
Area Ratio (A_2/A_1) = 0.4	0.3
Area Ratio (A_2/A_1) = 0.6	0.2
Area Ratio (A_2/A_1) = 0.7	0.1

Example 4:

A pipe transmits water from a tank A to point C that is lower than water level in the tank by 4 m. The pipe is 100 mm diameter and 15 m long.

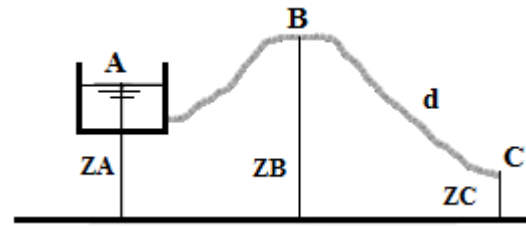

The highest point on the pipe B is 1.5 m above water level in the tank and 5 m long from the tank. The friction factor ($4f$) is 0.08, with sharp inlet and outlet to the pipe.

- Determine the velocity of water leaving the pipe at C?
- Calculate the pressure in the pipe at the point B?

Solution

(a) Applying Bernoulli's equation between A and C,

$$\text{Head loss due to entry (tank exit, from table)} = 0.5 (v_c^2/2g)$$

$$\text{Head loss due to exit into air without contraction} = 0$$

$$Z_A + 0 + 0 = Z_C + 0 + (v_c^2/2g) + 0.5 (v_c^2/2g) + 0 + \frac{4 f L v_c^2}{2 g d}$$

$$4 = (v_c^2/2g) \times \{1 + 0.5 + (4 \times 0.08 \times 15)/0.1\}$$

$$\therefore v_C = 1.26 \text{ m/s}$$

(b) Applying Bernoulli's equation between A and B,

$$Z_A + 0 + 0 = Z_B + P_B/\rho g + (v_B^2/2g) + 0.5 (v_B^2/2g) + \frac{4 f L v_B^2}{2 g d}$$

$$- 1.5 = P_B/(1000 \times 9.81) + (1.26^2/2 \times 9.81) * \{1 + 0.5 + (4 \times 0.08 \times 5)/0.1\}$$

$$\therefore P_B = - 28.61 \text{ kN/m}^2$$

7-3 Flow through Pipe Systems:

Pipes in Series:

Pipes in series are pipes with different diameters and lengths connected together forming a pipe line. Consider pipes in series discharging water from a tank with higher water level to another with lower water level, as shown in the figure.

58

Neglecting secondary losses, it is obvious that the total head loss H_L between the two tanks is the sum of the friction losses through the pipe line.

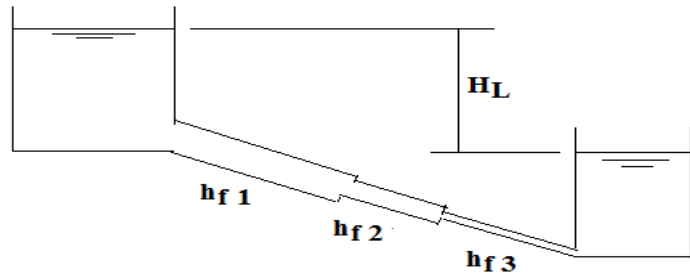

Friction losses through the pipe line are the sum of friction loss of each pipe.

$$H_L = h_{f1} + h_{f2} + h_{f3} + \dots$$

$$H_L = \frac{4f_1 L_1 v_1^2}{2gd_1} + \frac{4f_2 L_2 v_2^2}{2gd_2} + \frac{4f_3 L_3 v_3^2}{2gd_3} + \dots$$

OR:

$$H_L = \frac{32f_1 L_1 Q^2}{\pi^2 g d_1^5} + \frac{32f_2 L_2 Q^2}{\pi^2 g d_2^5} + \frac{32f_3 L_3 Q^2}{\pi^2 g d_3^5} + \dots$$

Pipes in Parallel:

Pipes in parallel are pipes with different diameters and same lengths, where each pipe is connected separately to increase the discharge. Consider pipes in parallel discharging water from a tank with higher water level to another with lower water level, as shown in the figure.

Neglecting minor losses, it is obvious that the total head loss H_L between the two tanks is the same as the friction losses through each pipe.

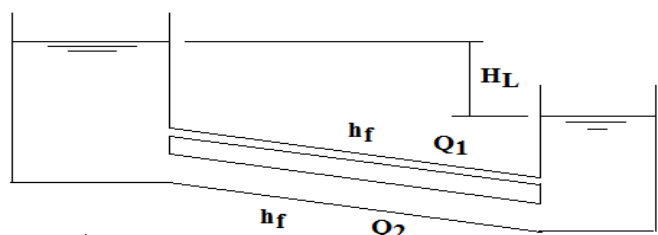

The friction losses through all pipes are the same, and all pipes discharge water independently.

$$H_L = h_{f1} = h_{f2} = \dots$$

$$L_1 = L_2 = L$$

$$H_L = \frac{4 f_1 L v_1^2}{2 g d_1} = \frac{4 f_2 L v_2^2}{2 g d_2} = \dots$$

$$H_L = \frac{32 f_1 L Q_1^2}{\pi^2 g d_1^5} = \frac{32 f_2 L Q_2^2}{\pi^2 g d_2^5} = \dots$$

$$Q = Q_1 + Q_2$$

Example 5:

A pipe, 40 m long, is connected to a water tank at one end and flows freely in atmosphere at the other end. The diameter of pipe is 15 cm for first 25 m from the tank, and then the diameter is suddenly enlarged to 30 cm. Height of water in the tank is 8 m above the centre of pipe. Darcy's coefficient is 0.01.

Determine the discharge neglecting minor losses?

Solution

Loss due to friction, $h_{Lf} = h_{f1} + h_{f2}$

$$h_f = \frac{32 f L Q^2}{\pi^2 g d^5} \quad f = 0.01$$

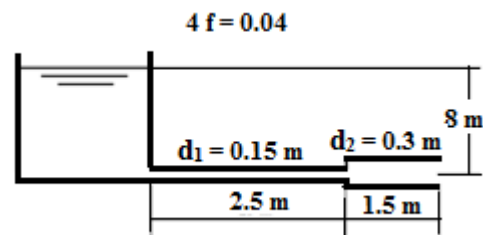

$$\text{Total losses, } h_T = Q^2 \left(\frac{32 f L_1}{\pi^2 g d_1^5} + \frac{32 f L_2}{\pi^2 g d_2^5} \right)$$

$$8 = Q^2 \left(\frac{(32 \times 0.01) \times (25)}{\pi^2 g (0.15)^5} + \frac{(32 \times 0.01) (15)}{\pi^2 g (0.3)^5} \right)$$

$$\therefore Q = 0.087 \text{ m}^3/\text{sec}$$

Example 6:

Two pipes are connected in parallel between two reservoirs that have difference in levels of 3.5 m. The length, the diameter, and friction factor (4 f) are 2400 m, 1.2 m, and 0.026 for the first pipe and 2400 m, 1 m, and 0.019 for the second pipe.

60

Calculate the total discharge between the two reservoirs?

Solution

$$H_L = \frac{32 f_1 L Q_1^2}{\pi^2 g d_1^5} = \frac{32 f_2 L Q_2^2}{\pi^2 g d_2^5}$$

$$3.5 = \frac{32 f_1 L Q_1^2}{\pi^2 g d_1^5} = \frac{8 \times 0.026 \times 2400 \times Q_1^2}{\pi^2 \times 9.81 \times 1.2^5}$$

$$Q_1 = 1.29 \text{ m}^3/\text{sec}$$

$$3.5 = \frac{32 f_2 L Q_2^2}{\pi^2 g d_2^5} = \frac{8 \times 0.019 \times 2400 \times Q_2^2}{\pi^2 \times 9.81 \times 1^5}$$

$$Q_2 = 0.96 \text{ m}^3/\text{sec}$$

$$\therefore Q = Q_1 + Q_2 = 1.29 + 0.96 = 2.25 \text{ m}^3/\text{sec}$$

Example 7:

Two reservoirs have 6 m difference in water levels, and are connected by a pipe 60 cm diameter and 3000 m long. Then, the pipe branches into two pipes each 30 cm diameter and 1500 m long. The friction coefficient is 0.01.

61

Neglecting minor losses, determine the flow rates in the pipe system?

Solution

$$h_f = h_{f1} + h_{f2}$$

$$6 = h_{f1} + h_{f2}$$

$$6 = k_1 Q_1^2 + k_2 Q_2^2$$

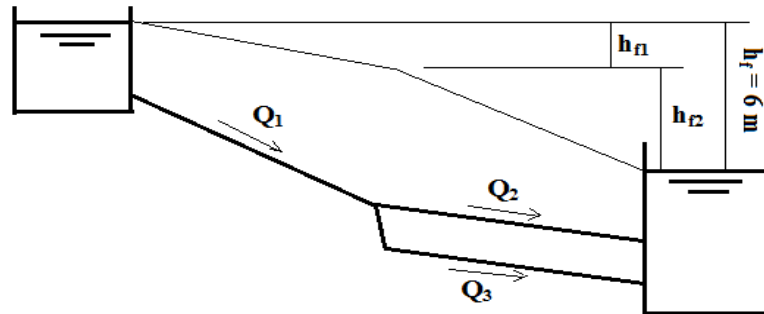

$$k_1 = \frac{32 f_1 L_1}{\pi^2 g d_1^5} = \frac{32 * 0.01 * 3000}{\pi^2 * 9.81 * 0.6^5} = 127.64$$

$$k_2 = \frac{32 f_2 L_2}{\pi^2 g d_2^5} = \frac{32 * 0.01 * 1500}{\pi^2 * 9.81 * 0.3^5} = 4084.48$$

$$k_2 = 32 k_1$$

$$\therefore 6 = k_1 Q_1^2 + 32 k_1 Q_2^2$$

$$h_{f2} = h_{f3} \quad \& \quad k_2 = k_3 \quad \therefore Q_2 = Q_3$$

$$Q_1 = Q_2 + Q_3 = 2 Q_2$$

$$\therefore 6 = k_1 Q_1^2 + 8 k_1 Q_1^2 = 9 k_1 Q_1^2 = (9 * 127.64) Q_1^2 = 1148.76 Q_1^2$$

$$\therefore Q_1 = 0.072 \text{ m}^3/\text{s}$$

$$\& Q_2 = 0.036 \text{ m}^3/\text{s}$$

Example 8:

Two tanks A and B have 70 m difference in water levels, and are connected by a pipe 0.25 m diameter and 6 km long with 0.002 friction coefficient. The pipe is tapped at its mid point to leak out 0.04 m³/s flow rate. Minor losses are ignored.

62

Determine the discharge leaving tank A?

Find the discharge entering tank B?

Solution

$$h_f = h_{f1} + h_{f2}$$

$$70 = h_{f1} + h_{f2}$$

$$70 = k_1 Q_1^2 + k_2 Q_2^2$$

$$k_1 = k_2 = \frac{32 f L}{\pi^2 g d^5} = \frac{32 * 0.002 * 3000}{\pi^2 * 9.81 * 0.25^5} = 2032.7$$

$$\therefore 70 = k_1 Q_1^2 + k_1 Q_2^2$$

$$Q_1 = Q_2 + Q_3 = Q_2 + 0.04$$

$$\therefore 70 = k_1 (Q_2 + 0.04)^2 + k_1 Q_2^2$$

$$= k_1 (Q_2^2 + 0.08 Q_2 + 0.0016) + k_1 Q_2^2$$

$$= k_1 Q_2^2 + 0.08 k_1 Q_2 + 0.0016 k_1 + k_1 Q_2^2$$

$$= 2 k_1 Q_2^2 + 0.08 k_1 Q_2 + 0.0016 k_1$$

$$= 4065.4 Q_2^2 + 162.6 Q_2 + 3.25$$

$$0.0172 = Q_2^2 + 0.04 Q_2 + 0.0008$$

$$Q_2^2 + 0.04 Q_2 - 0.0164 = 0$$

$$Q_2 = \frac{-0.04 \pm \sqrt{(-0.04)^2 - 4(1)(-0.0164)}}{2(1)}$$

$$\therefore Q_2 = 0.11 \text{ m}^3/\text{s} \quad \& \quad Q_1 = 0.15 \text{ m}^3/\text{s}$$

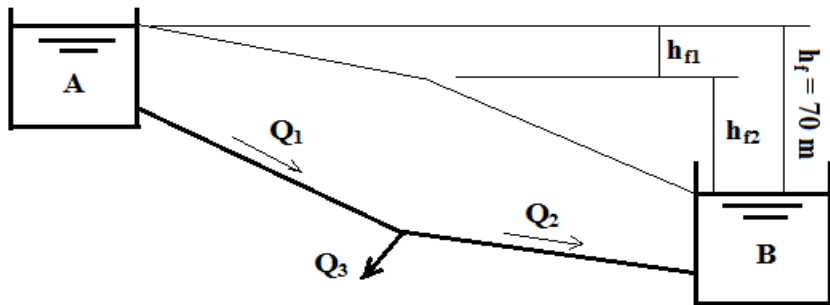

Example 9:

A tank transmits 100 L/s of water to the point C where the pressure is maintained at 1.5 kg/cm². The first part AB of the pipe line is 50 cm diameter and 2.5 km long, and the second part BC is 25 cm diameter and 1.5 km long. The friction coefficient is 0.005 and minor losses are ignored.

63

Assuming level at C is (0.0); find the water level (L) in the tank?

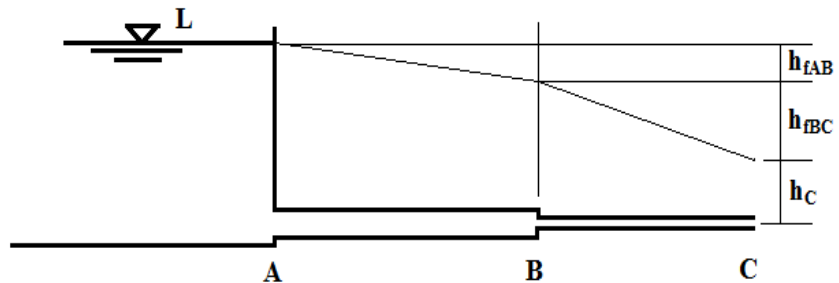
Solution

$$h_C = P_C / \gamma = 1500 / 1 = 1500 \text{ cm} = 15 \text{ m}$$

$$h_C = 15 = L - h_{fAB} - h_{fBC}$$

$$h_{fAB} = \frac{32 f_1 L_1}{\pi^2 g d_1^5} = \frac{32 * 0.005 * 2500}{\pi^2 * 9.81 * 0.5^5} = 1.32$$

$$h_{fBC} = \frac{32 f_2 L_2}{\pi^2 g d_2^5} = \frac{32 * 0.005 * 1500}{\pi^2 * 9.81 * 0.25^5} = 25.38$$

$$15 = L - 1.32 - 25.38$$

$$\therefore L = 41.7 \text{ m}$$

Example 10:

Three water tanks A, B and C with water surface levels (100.00), (50.00) and (10.00) m are connected by pipes AJ, BJ and CJ to a common joint J of a level (45.00) m. The three pipes have the same length, diameter and friction coefficient.

64

- Calculate the head at the joint J?
- Determine the discharge in each pipe?

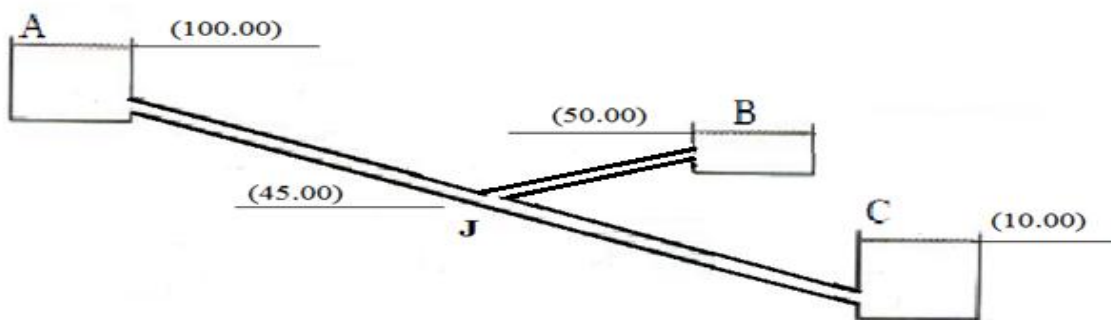
Solution

Assume, $Q_{AJ} = Q_{JB} + Q_{JC}$

Applying Bernoulli's equation between A and J:

$$H_A = H_J + h_{f AJ}$$

$$100 + 0 + 0 = H_J + h_{f AJ}$$

$$100 - H_J = h_{f AJ} = K Q_{AJ}^2$$

where, $K = 32 f l / \pi^2 g d^5$

$$Q_{AJ} = (100 - H_J)^{1/2} / (K)^{1/2} \quad \dots\dots\dots (1)$$

Similarly, applying Bernoulli's equation between J and B:

$$H_J = H_B + h_{f JB}$$

$$H_J - 50 = h_{f JB} = K Q_{JB}^2$$

$$Q_{JB} = (H_J - 50)^{1/2} / (K)^{1/2} \dots\dots\dots (2)$$

Also, applying Bernoulli's equation between J and C:

$$H_J = H_C + h_{f JC}$$

$$H_J - 10 = h_{f JC} = K Q_{JC}^2$$

$$Q_{JC} = (H_J - 10)^{1/2} / (K)^{1/2} \dots\dots\dots (3)$$

Solving equations 1, 2 and 3 by trial and error, we get:

Assumed H _J	Q _{AJ} x (K) ^{1/2}	J _B x (K) ^{1/2}	Q _{JC} x (K) ^{1/2}	(Q _{JB} +Q _{JC})x(K) ^{1/2}
70	5.48	4.47	7.745	12.216
60	6.325	3.162	7.07	10.233
53	6.855	1.732	6.557	8.289
51	7	1	6.4	7.4
50.5	7.036	0.707	6.364	7.07
50.45	7.039	0.671	6.36	7.031
50.4	7.043	0.632	6.356	6.988
50	7.071	0	6.324	6.324

From the table:

$$H_J = 50.45 \text{ m}$$

$$Q_{AJ} = 7.039 / (K)^{1/2}$$

$$Q_{JB} = 0.671 / (K)^{1/2}$$

$$Q_{JC} = 6.36 / (K)^{1/2}$$

It has to be noted that if H_J < 50, then the flow will be from B to J.

Exercise:

Three water tanks A, B and C are connected to a joint J by three pipes AJ, BJ and CJ such that the water level in tank A is 40 m higher than tank B and 55 m higher than tank C. Each pipe is 1500 m long, 0.3 m diameter and $f = 0.01$.

66

Calculate the discharges and directions of flow?

Solution

Taking the water level in the tank C as a datum, the results are:

$$H_J = 18 \text{ m}$$

$$Q_{AJ} = 0.134 \text{ m}^3/\text{sec}$$

$$Q_{JB} = 0.038 \text{ m}^3/\text{sec}$$

$$Q_{JC} = 0.094 \text{ m}^3/\text{sec}$$

Chapter 8

DIMENSIONAL ANALYSIS

8-1 Dimensional Homogeneity

8-2 Dimensionless Numbers

8-3 Bucking-Ham Theorem or π - Theorem

67

8-1 Dimensional Homogeneity:

Every term in an equation when reduced to the fundamental dimensions (M, L, T) or (F, L, T) must contain identical powers of each dimension.

For example, $H = Z + (P/\gamma) + (v^2 / 2g)$
that is to say: $L = L + (F / L^2) / (F / L^3) + (L^2/T^2) / (L/T^2)$
 $\therefore L = L + L + L = L$

8-2 Dimensionless Numbers:

Quantities that do not have the fundamental dimensions (M, L, T) or (F, L, T).

For example: $2 - \pi - \theta - F_n - R_n$ ----- etc.

8-3 Bucking-Ham Theorem or π - Theorem:

For the dimensional homogeneous equation:

$$A_1 = f (A_2, A_3, \dots, A_n)$$

1- $\phi (A_1, A_2, \dots, A_n) = 0$ \therefore Number of variables = n

2- Choose 3 repeating variables (m = 3), as follows:

The first represents the **geometric properties** (L, w, d, ---).

The second represents **kinematic or fluid properties** (γ , ρ , μ , ---).

The third represents **dynamic or flow properties** (v, a, Q, P, ---).

It has to be noted that only one variable is chosen from each group of properties. Dimensionless numbers must not be chosen.

For our discussion, let the three repeating variables are A_1 , A_2 and A_3 .

3- Number of π - terms = $n - m$, as follows:

$$\pi_1 = A_1^{a_1} A_2^{b_1} A_3^{c_1} A_4^{-1} = M^0 L^0 T^0$$

$$\pi_2 = A_1^{a_2} A_2^{b_2} A_3^{c_2} A_5^{-1} = M^0 L^0 T^0$$

$$\pi_3 = A_1^{a_3} A_2^{b_3} A_3^{c_3} A_6^{-1} = M^0 L^0 T^0$$

·
·
·
·
·

$$\pi_{(n-3)} = A_1^{a_{(n-3)}} A_2^{b_{(n-3)}} A_3^{c_{(n-3)}} A_{(n-3)}^{-1} = M^0 L^0 T^0$$

4- Determine the values of the powers in each π - term by equating the powers RHS and LHS.

$$5- \quad \phi (\pi_1, \pi_2, \dots, \pi_{n-3}) = 0$$

$$\underline{OR} \quad \pi_1 = \psi (\pi_2, \pi_3, \dots, \pi_{n-3})$$

It has to be noted that any π - term can be multiplied by or divided by any other π - term or any number or any quantity.

Example:

The discharge Q through an orifice depends on the pressure P , the density of fluid ρ and the diameter of the orifice d .

Determine a general formula for the discharge?

Solution

$$(Q, P, \rho, d) = 0 \quad \therefore n = 4$$

Choose ρ (fluid), Q (flow) and d (geometry) as repeating variables. $\therefore m = 3$

69

$$\text{Number of } \pi \text{ - terms} = m - n = 4 - 3 = 1$$

$$\pi_1 = \rho^a Q^b d^c P^{-1} = M^0 L^0 T^0$$

$$(M L^{-3})^a (L^3 T^{-1})^b (L)^c (M L^{-1} T^{-2})^{-1} = M^0 L^0 T^0$$

$$\underline{M^{a-1} = M^0} \quad : \quad a - 1 = 0 \quad \quad \quad \mathbf{a = 1}$$

$$\underline{L^{-3a+3b+c+1} = L^0} : \quad -3a + 3b + c + 1 = 0 \quad \dots\dots\dots (1)$$

$$\underline{T^{-b+2} = T^0} \quad : \quad -b + 2 = 0 \quad \quad \quad \mathbf{b = 2}$$

$$\text{In equation (1),} \quad -3 + 6 + c + 1 = 0 \quad \quad \quad \mathbf{c = -4}$$

$$\therefore \pi_1 = \rho Q^2 d^{-4} P^{-1} = (\rho / P) (Q / d^2)^2$$

$$\phi [(\rho / P) (Q / d^2)^2] = 0$$

$$\psi [(\rho / P)^{1/2} (Q / d^2)] = 0$$

$$(Q / d^2) = K / (\rho / P)^{1/2} \quad \text{where, } K \text{ is a constant.}$$

$$Q = K d^2 / (\rho / P)^{1/2} = K d^2 (P / \rho)^{1/2}$$

$$\underline{\text{But,}} \quad P = \rho g h \quad \quad \underline{\text{Then,}} \quad Q = K d^2 (g h)^{1/2}$$

Multiplying both sides by $(4 \times \pi \times 2^{1/2})$,

$$Q = K d^2 (g h)^{1/2} \times [(4 \times \pi \times 2^{1/2}) / (4 \times \pi \times 2^{1/2})]$$

$$\therefore Q = (2^{3/2} K / \pi) \times (\pi d^2 / 4) \times (2 g h)^{1/2}$$

$$\therefore Q = C_d A (2 g h)^{1/2} \quad \text{where, } C_d = (2^{3/2} K / \pi)$$

Exercise:

The pressure grade (dP/dL) in a turbulent flow through pipes is dependent of the pipe diameter (d), the mean velocity (v), the density (ρ), the dynamic viscosity (μ) and the roughness height (k).

Determine a general formula for the pressure grade?

Solution

$$(dP/dL) = (\rho v^2 / d) * f(R_n, (d/k))$$

Where, $R_n = \rho v d / \mu$

Chapter 9**MODEL ANALYSIS**

9-1 Model Analysis

9-2 Hydraulic Similarity

9-3 Classification of Models

71

9-1 Model Analysis:

It is a scientific method to predict the performance of hydraulic structures, systems and machines. A model is prepared and tested in a laboratory for the working and behavior of the proposed hydraulic system. The hydraulic system, for which a model is prepared, is known as prototype.

9-2 Hydraulic Similarity:

For the model analysis, there should be a complete similarity between the prototype and its model. This similarity is known as hydraulic similarity or hydraulic similitude. *Hydraulic similarity includes three types:*

A- Geometric similarity:

The prototype and its model are identical in shape but are different in size. The ratios of all corresponding linear dimensions are equal.

$$\text{Scale (linear) ratio } L_r = L_m / L_p = d_m / d_p = y_m / y_p$$

Where, L: length, d: diameter and y: depth.

B- Kinematic similarity:

The prototype and its model have identical motions or velocities. The ratios of the corresponding velocities at corresponding points are equal.

$$\text{Velocity ratio } v_r = v_{1m} / v_{1p} = v_{2m} / v_{2p} = \dots\dots\dots$$

C- Dynamic similarity:

The prototype and its model have identical forces. The ratios of the corresponding forces acting at corresponding points are equal.

$$\text{Force ratio } F_R = F_{1m} / F_{1p} = F_{2m} / F_{2p} = \dots\dots\dots$$

Forces can be divided into external forces and internal forces.

External forces include:

- 1- Pressure force ($F = P A$).
- 2- Gravity force ($F = m g$).

Internal forces include:

- 1- Inertia force ($F = m a$).
- 2- Viscosity force ($F = \tau A = (\mu v / L) (L^2) = \mu v L$).
- 3- Surface tension force ($F = \sigma L$).
- 4- Elasticity force ($F = K A$).

In general, the force ratio is constant and equal for the different types of forces, for a prototype and its model. Actually, some forces may not act or may be very small (neglected).

The ratio of the inertia force to any other present (predominating) force provides the known dimensionless numbers, and will be used for solving problems of model analysis. However, only two forces are going to be discussed.

1- Gravity force is present:

E.g. flow through open channels, flow over weirs, and surface waves.

$$\frac{F_{im}}{F_{ip}} = \frac{F_{gm}}{F_{gp}}$$

$$\frac{F_{im}}{F_{gm}} = \frac{F_{ip}}{F_{gp}}$$

$$\frac{\rho_m L_m^2 v_m^2}{\rho_m L_m^3 g_m} = \frac{\rho_p L_p^2 v_p^2}{\rho_p L_p^3 g_p}$$

$$\frac{v_m^2}{L_m g_m} = \frac{v_p^2}{L_p g_p}$$

$$\frac{v_m}{(L_m g_m)^{1/2}} = \frac{v_p}{(L_p g_p)^{1/2}}$$

That is to say that $F_m = F_p$, where F is Froud number.

$$\frac{v_m}{v_p} \frac{(L_p g_p)^{1/2}}{(L_m g_m)^{1/2}} = 1$$

$$\frac{v_m}{v_p} \frac{1}{(L_m/L_p)^{1/2} (g_m/g_p)^{1/2}} = 1$$

$$\frac{v_r}{(L_r g_r)^{1/2}} = 1$$

Which is Froud's law.

If $g_r = 1$, then $v_r = (L_r)^{1/2}$

2- Viscous force is present:

E.g. flow through pipes, hydraulic measuring devices (flow meters), and hydraulic machines (pumps and turbines).

$$\frac{F_{im}}{F_{ip}} = \frac{F_{vm}}{F_{vp}}$$

$$\frac{F_{im}}{F_{vm}} = \frac{F_{ip}}{F_{vp}}$$

$$\frac{F_{im}}{F_{vm}} = \frac{\rho_m L_m^2 v_m^2}{\mu_m L_m v_m} = \frac{\rho_m L_m v_m}{\mu_m} = \frac{\rho_m L_m v_m}{\rho_m \nu_m} = \frac{L_m v_m}{\nu_m}$$

$$\frac{L_m v_m}{\nu_m} = \frac{L_p v_p}{\nu_p}$$

That is to say that $\mathbf{R}_m = \mathbf{R}_p$, where R is Reynold's number.

$$\frac{L_m v_m \nu_p}{L_p v_p \nu_m} = 1$$

$$\frac{\mathbf{L}_r \mathbf{v}_r}{\nu_r} = 1$$

Which is Reynolds's law.

Then, $\mathbf{v}_r = \nu_r / \mathbf{L}_r$

9-3 Classification of Models:

A- Undistorted Models:

Geometric similarity is the same for both horizontal and vertical linear dimensions.

B- Distorted Models:

Geometric similarity is different for both horizontal and vertical linear dimensions. Scale ratios will be L_{Th} and L_{Tv} . For example, studying a river basin.

Example:

A model for a spillway has to be built in a laboratory where the maximum capacity of the pump is 9 cfs. The prototype has 300 cfs maximum discharge and 5 ft head on the crest.

1. Determine the scale ratio for the model?
2. Calculate the head on the crest of the model?
3. Find the time in model corresponding to 36 hours in prototype?
4. Determine the loss of power in prototype corresponding to observed 0.05 HP in model?

75

Solution

$$(1) \quad Q_r = Q_m / Q_p = 9 / 300 = 3 / 100$$

$$Q_r = A_m v_m / A_p v_p = L_m^2 v_m / L_p^2 v_p = L_r^2 v_r$$

The case is a spillway, i.e. flow through open channels, so the gravity force is the present force. Thus, Froud's law is applied.

$$\frac{v_r}{(L_r g_r)^{1/2}} = 1$$

$$g_r = 1, \text{ then } v_r = (L_r)^{1/2}$$

$$Q_r = (L_r)^{5/2}$$

$$L_r = (Q_r)^{2/5} = (3 / 100)^{2/5} = 0.25 = 1 / 4$$

$$(2) \quad L_r = h_m / h_p$$

$$h_m = h_p \times L_r = 5 \times 0.25 = 1.25 \text{ ft.}$$

$$(3) \quad T_r = L_r / v_r = (L_r) / (L_r)^{1/2} = (L_r)^{1/2} = (0.25)^{1/2} = T_m / T_p$$

$$T_m = T_p \times T_r = 36 \times (0.25)^{1/2} = 18 \text{ hours}$$

$$(4) \quad P_r = P_m / P_p = (\gamma_m Q_m h_m / 75) / (\gamma_p Q_p h_p / 75)$$

$$= (\gamma_r Q_r h_r) = (1) (L_r)^{5/2} (L_r) = (L_r)^{7/2}$$

$$P_p = P_m / P_r = 0.05 / (0.25)^{7/2} = 6.4 \text{ HP}$$

References:

- Buddhi N. Hewakandamby, "A First Course in Fluid Mechanics for Engineers", www.bookboon.com
- Dawei Han, "Concise Hydraulics", www.bookboon.com
- R. K. Bansal, "A Textbook of Fluid Mechanics", Firewall Media, 2005.
- R. S. Khurmi, "A Text Book Of Hydraulics, Fluid Mechanics and Hydraulic Machines", S. Chand & Company Ltd, Ram Nagar, New Delhi, India, 1980.
- T. Al-Shemmeri, "Engineering Fluid Mechanics", www.bookboon.com
- T. Al-Shemmeri, "Engineering Fluid Mechanics Solution Manual", www.bookboon.com
- udel.edu/~inamdar/EGTE215/Pipeflow.pdf
- www.ajdesigner.com/index_fluid_mechanics.php
- www.efm.leeds.ac.uk/CIVE/CIVE2400/pipe_flow2.pdf
- www.en.wikipedia.org/wiki/Darcy's_law
- www.en.wikipedia.org/wiki/Hazen-Williams
- www.engineeringtoolbox.com/mercury-d_1002.html
- www.LMNOeng.com

Lecture Notes - Fluid Mechanics, 3rd edition

© 2015 Alaa Nabil El-Hazek

ISBN 960-616-14-3554-6