

Chapter 8

Network Security

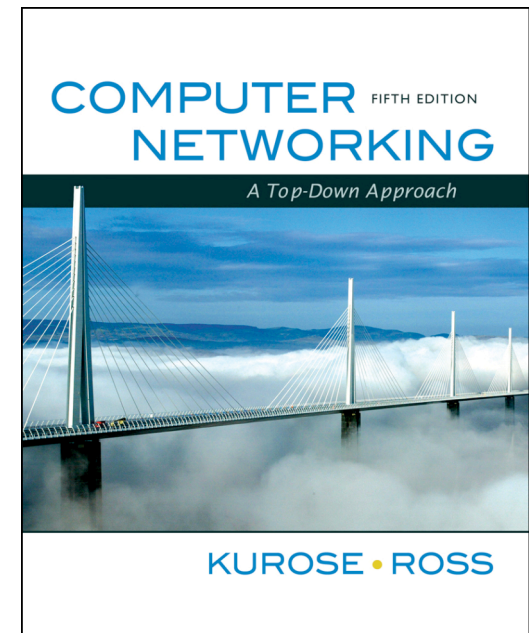

*Computer Networking:
A Top Down Approach ,
5th edition.*

*Jim Kurose, Keith Ross
Addison-Wesley, April
2009.*

Chapter 8: Network Security

Chapter goals:

- ❑ understand principles of network security:
 - cryptography and its *many* uses beyond "confidentiality"
 - authentication
 - message integrity
- ❑ security in practice:
 - firewalls and intrusion detection systems
 - security in application, transport, network, link layers

Chapter 8 roadmap

8.1 What is network security?

8.2 Principles of cryptography

8.3 Message integrity

8.4 Securing e-mail

8.5 Securing TCP connections: SSL

8.6 Network layer security: IPsec

8.7 Securing wireless LANs

8.8 Operational security: firewalls and IDS

What is network security?

Confidentiality: only sender, intended receiver should "understand" message contents

- sender encrypts message
- receiver decrypts message

Authentication: sender, receiver want to confirm identity of each other

Message integrity: sender, receiver want to ensure message not altered (in transit, or afterwards) without detection

Access and availability: services must be accessible and available to users

Friends and enemies: Alice, Bob, Trudy

- ❑ well-known in network security world
- ❑ Bob, Alice (lovers!) want to communicate "securely"
- ❑ Trudy (intruder) may intercept, delete, add messages

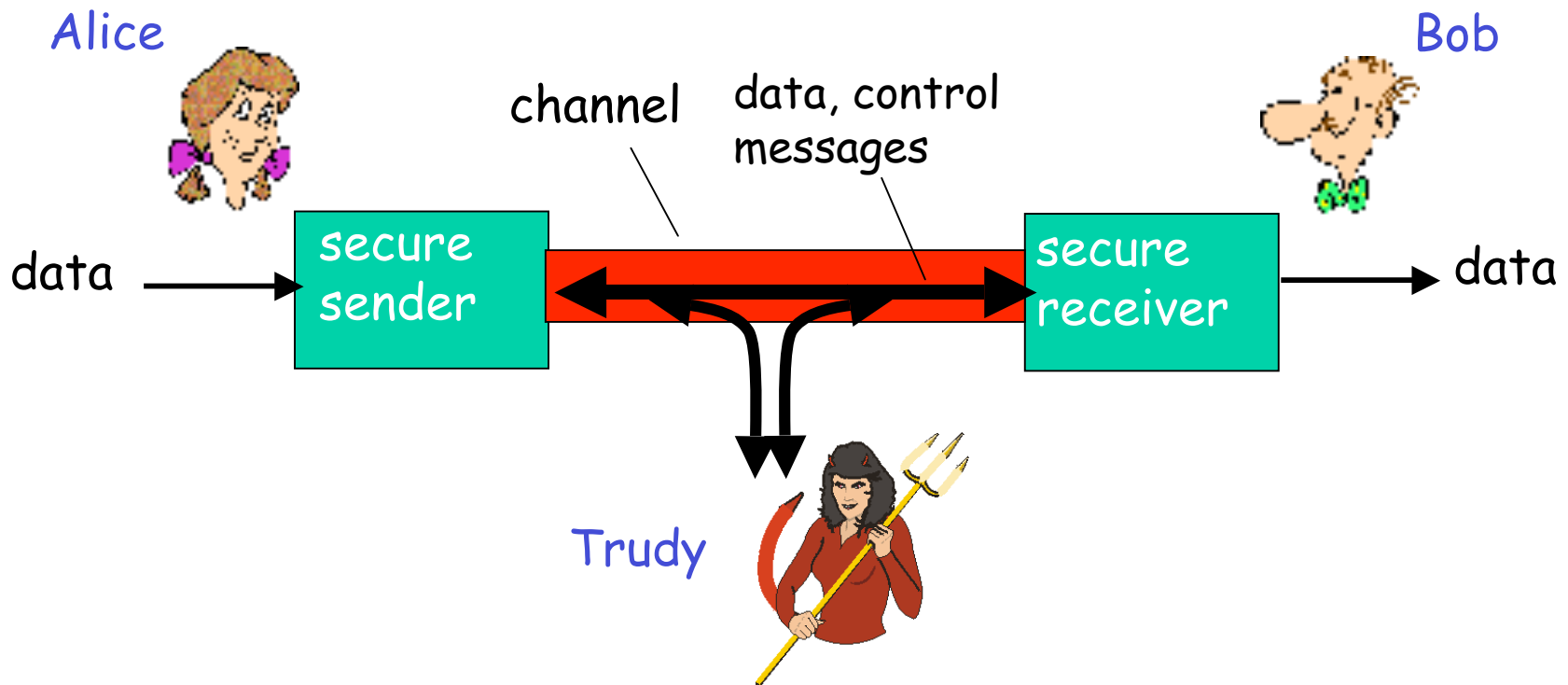

Who might Bob, Alice be?

- ❑ ... well, *real-life* Bobs and Alices!
- ❑ Web browser/server for electronic transactions (e.g., on-line purchases)
- ❑ on-line banking client/server
- ❑ DNS servers
- ❑ routers exchanging routing table updates
- ❑ other examples?

There are bad guys (and girls) out there!

Q: What can a "bad guy" do?

A: A lot! See section 1.6

- *eavesdrop*: intercept messages
- actively *insert* messages into connection
- *impersonation*: can fake (spoof) source address in packet (or any field in packet)
- *hijacking*: "take over" ongoing connection by removing sender or receiver, inserting himself in place
- *denial of service*: prevent service from being used by others (e.g., by overloading resources)

Chapter 8 roadmap

8.1 What is network security?

8.2 Principles of cryptography

8.3 Message integrity

8.4 Securing e-mail

8.5 Securing TCP connections: SSL

8.6 Network layer security: IPsec

8.7 Securing wireless LANs

8.8 Operational security: firewalls and IDS

The language of cryptography

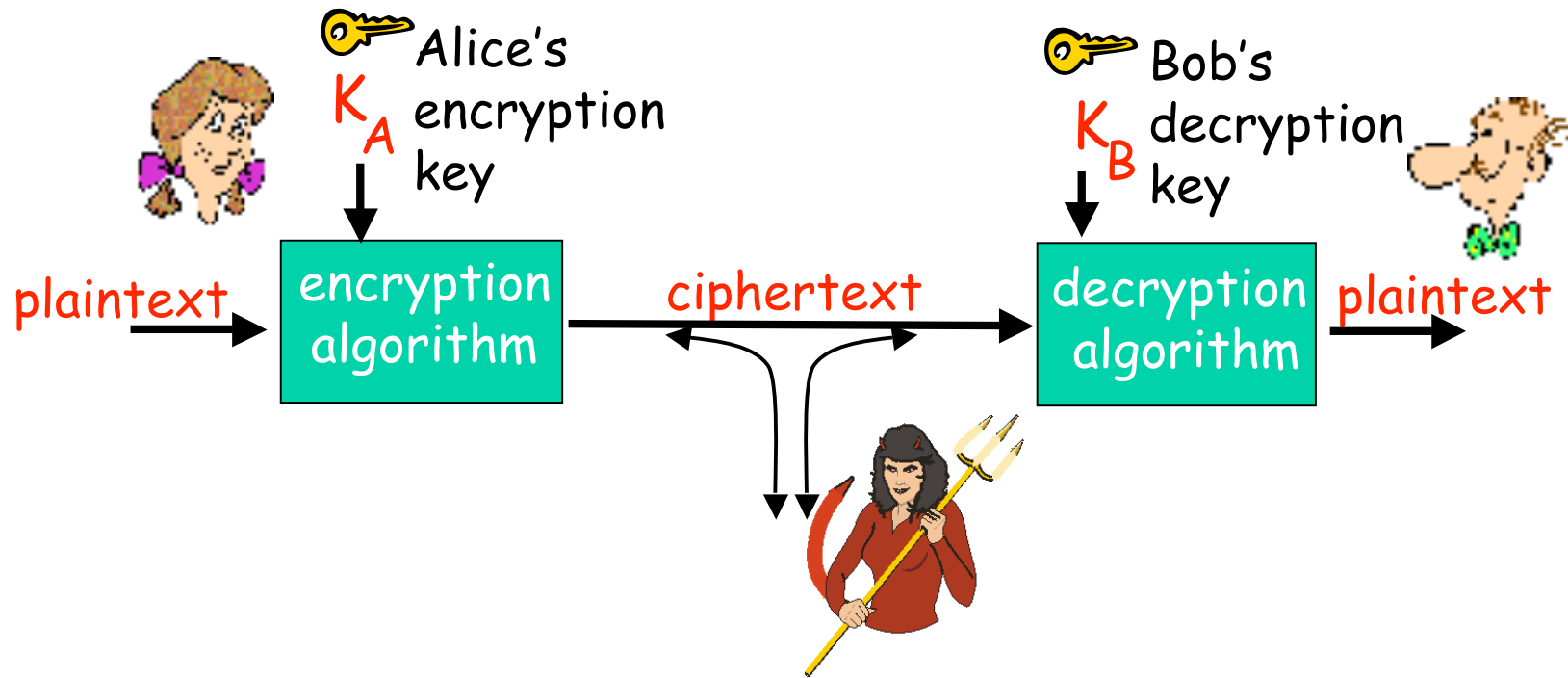

m plaintext message

$K_A(m)$ ciphertext, encrypted with key K_A

$m = K_B(K_A(m))$

Polyalphabetic encryption

- ❑ n monoalphabetic ciphers, M_1, M_2, \dots, M_n
- ❑ Cycling pattern:
 - e.g., $n=4$, M_1, M_3, M_4, M_3, M_2 ; M_1, M_3, M_4, M_3, M_2 ;
- ❑ For each new plaintext symbol, use subsequent monoalphabetic pattern in cyclic pattern
 - dog: d from M_1 , o from M_3 , g from M_4
- ❑ Key: the n ciphers and the cyclic pattern

Breaking an encryption scheme

- ❑ **Cipher-text only attack:** Trudy has ciphertext that she can analyze
- ❑ **Two approaches:**
 - Search through all keys: must be able to differentiate resulting plaintext from gibberish
 - Statistical analysis
- ❑ **Known-plaintext attack:** trudy has some plaintext corresponding to some ciphertext
 - eg, in monoalphabetic cipher, trudy determines pairings for a,l,i,c,e,b,o,
- ❑ **Chosen-plaintext attack:** trudy can get the ciphertext for some chosen plaintext

Types of Cryptography

- ❑ Crypto often uses keys:
 - Algorithm is known to everyone
 - Only "keys" are secret
- ❑ Public key cryptography
 - Involves the use of two keys
- ❑ Symmetric key cryptography
 - Involves the use one key
- ❑ Hash functions
 - Involves the use of no keys
 - Nothing secret: How can this be useful?

Symmetric key cryptography

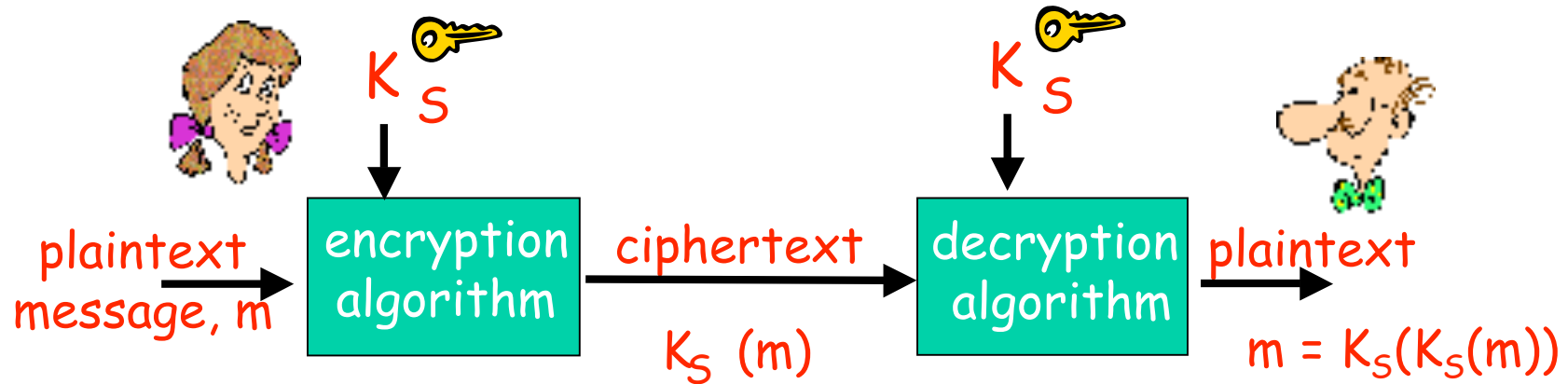

symmetric key crypto: Bob and Alice share same (symmetric) key: K_S

□ e.g., key is knowing substitution pattern in mono alphabetic substitution cipher

Q: how do Bob and Alice agree on key value?

Two types of symmetric ciphers

- ❑ Stream ciphers
 - encrypt one bit at time
- ❑ Block ciphers
 - Break plaintext message in equal-size blocks
 - Encrypt each block as a unit

Stream Ciphers

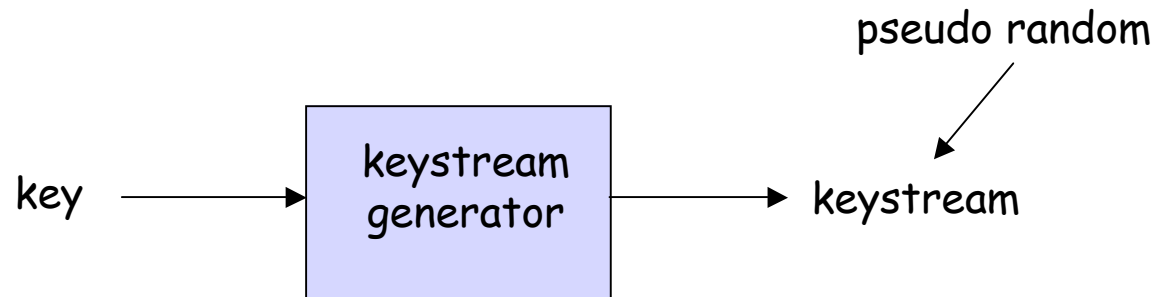

- ❑ Combine each bit of keystream with bit of plaintext to get bit of ciphertext
- ❑ $m(i)$ = i th bit of message
- ❑ $ks(i)$ = i th bit of keystream
- ❑ $c(i)$ = i th bit of ciphertext
- ❑ $c(i) = ks(i) \oplus m(i)$ (\oplus = exclusive or)
- ❑ $m(i) = ks(i) \oplus c(i)$

RC4 Stream Cipher

- RC4 is a popular stream cipher
 - Extensively analyzed and considered good
 - Key can be from 1 to 256 bytes
 - Used in WEP for 802.11
 - Can be used in SSL

Block ciphers

- ❑ Message to be encrypted is processed in blocks of k bits (e.g., 64-bit blocks).
- ❑ 1-to-1 mapping is used to map k -bit block of plaintext to k -bit block of ciphertext

Example with $k=3$:

<u>input</u>	<u>output</u>	<u>input</u>	<u>output</u>
000	110	100	011
001	111	101	010
010	101	110	000
011	100	111	001

What is the ciphertext for 010110001111 ?

Block ciphers

- ❑ How many possible mappings are there for $k=3$?
 - How many 3-bit inputs?
 - How many permutations of the 3-bit inputs?
 - Answer: 40,320 ; not very many!
- ❑ In general, $2^k!$ mappings; huge for $k=64$
- ❑ Problem:
 - Table approach requires table with 2^{64} entries, each entry with 64 bits
- ❑ Table too big: instead use function that simulates a randomly permuted table

Prototype function

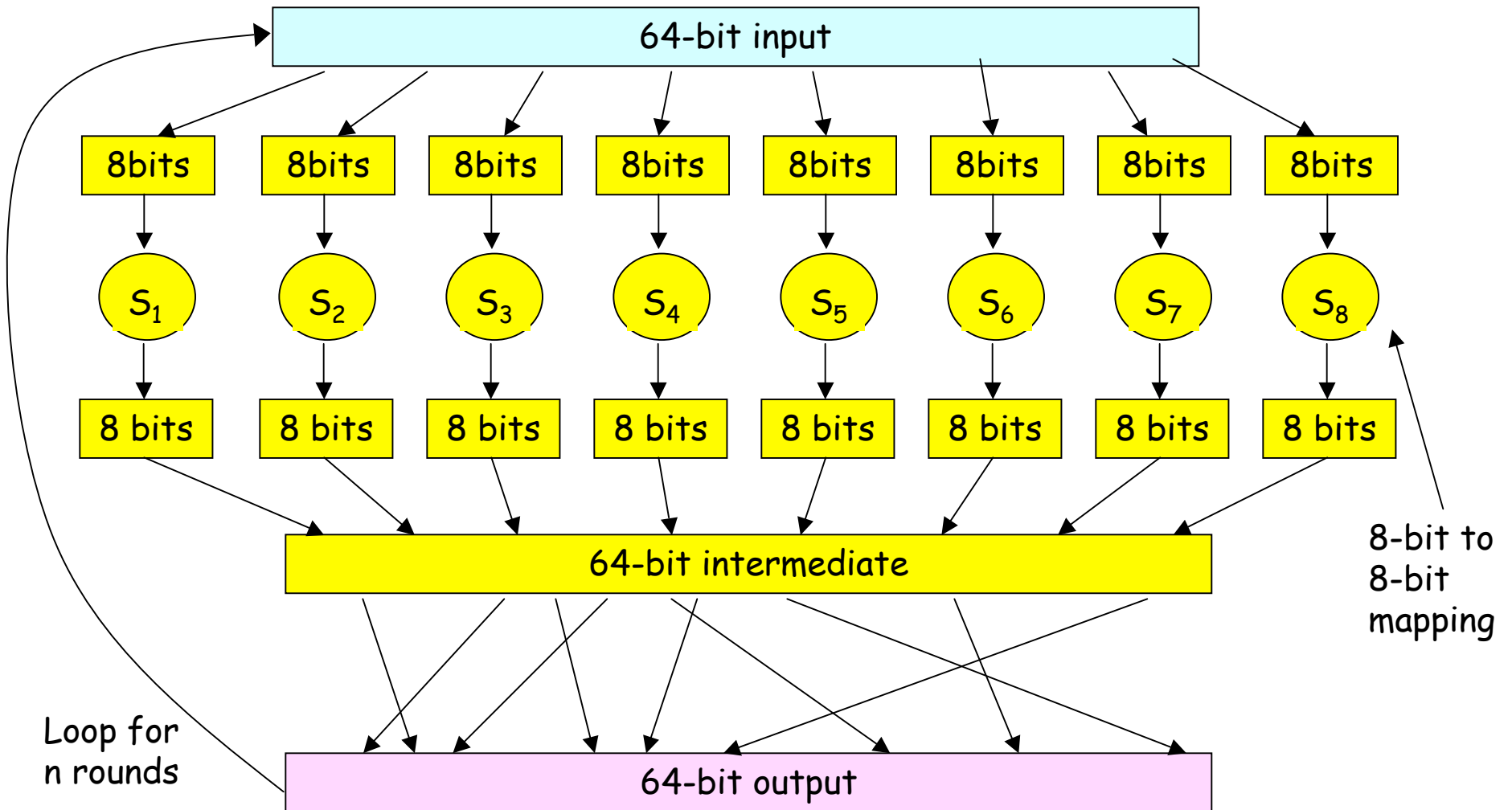

Why rounds in prototpe?

- ❑ If only a single round, then one bit of input affects at most 8 bits of output.
- ❑ In 2nd round, the 8 affected bits get scattered and inputted into multiple substitution boxes.
- ❑ How many rounds?
 - How many times do you need to shuffle cards
 - Becomes less efficient as n increases

Encrypting a large message

- ❑ Why not just break message in 64-bit blocks, encrypt each block separately?
 - If same block of plaintext appears twice, will give same cyphertext.
- ❑ How about:
 - Generate random 64-bit number $r(i)$ for each plaintext block $m(i)$
 - Calculate $c(i) = K_S(m(i) \oplus r(i))$
 - Transmit $c(i), r(i), i=1,2,\dots$
 - At receiver: $m(i) = K_S(c(i)) \oplus r(i)$
 - Problem: inefficient, need to send $c(i)$ and $r(i)$

Cipher Block Chaining (CBC)

- ❑ CBC generates its own random numbers
 - Have encryption of current block depend on result of previous block
 - $c(i) = K_S(m(i) \oplus c(i-1))$
 - $m(i) = K_S(c(i)) \oplus c(i-1)$
- ❑ How do we encrypt first block?
 - Initialization vector (IV): random block = $c(0)$
 - IV does not have to be secret
- ❑ Change IV for each message (or session)
 - Guarantees that even if the same message is sent repeatedly, the ciphertext will be completely different each time

Cipher Block Chaining

- ❑ cipher block: if input block repeated, will produce same cipher text:

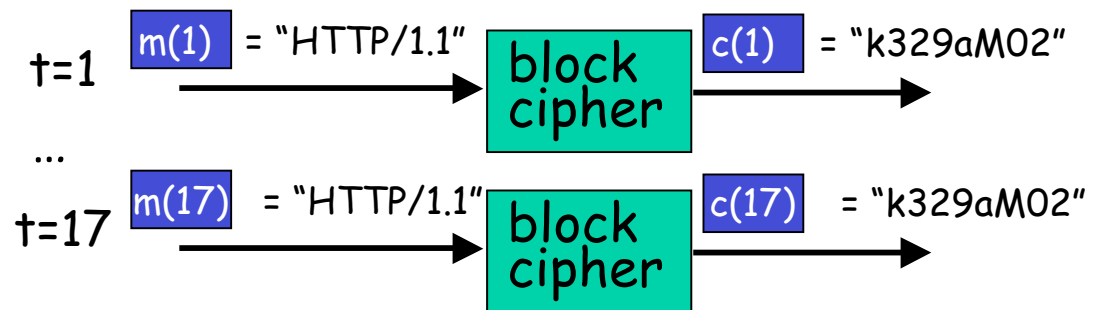

- ❑ *cipher block chaining:*
 - XOR ith input block, $m(i)$, with previous block of cipher text, $c(i-1)$
 - $c(0)$ transmitted to receiver in clear
 - what happens in "HTTP/1.1" scenario from above?

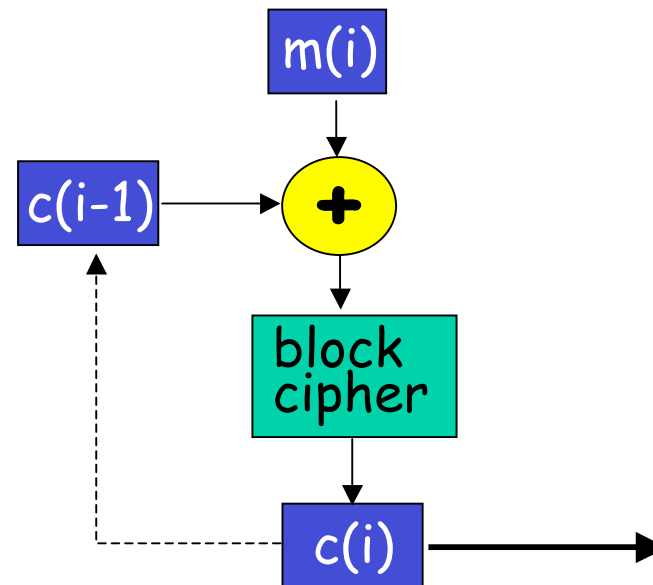

Symmetric key crypto: DES

DES: Data Encryption Standard

- ❑ US encryption standard [NIST 1993]
- ❑ 56-bit symmetric key, 64-bit plaintext input
- ❑ Block cipher with cipher block chaining
- ❑ How secure is DES?
 - DES Challenge: 56-bit-key-encrypted phrase decrypted (brute force) in less than a day
 - No known good analytic attack
- ❑ making DES more secure:
 - 3DES: encrypt 3 times with 3 different keys
--(actually encrypt, decrypt, encrypt)

Symmetric key crypto: DES

DES operation

initial permutation

16 identical "rounds" of
function application,
each using different
48 bits of key

final permutation

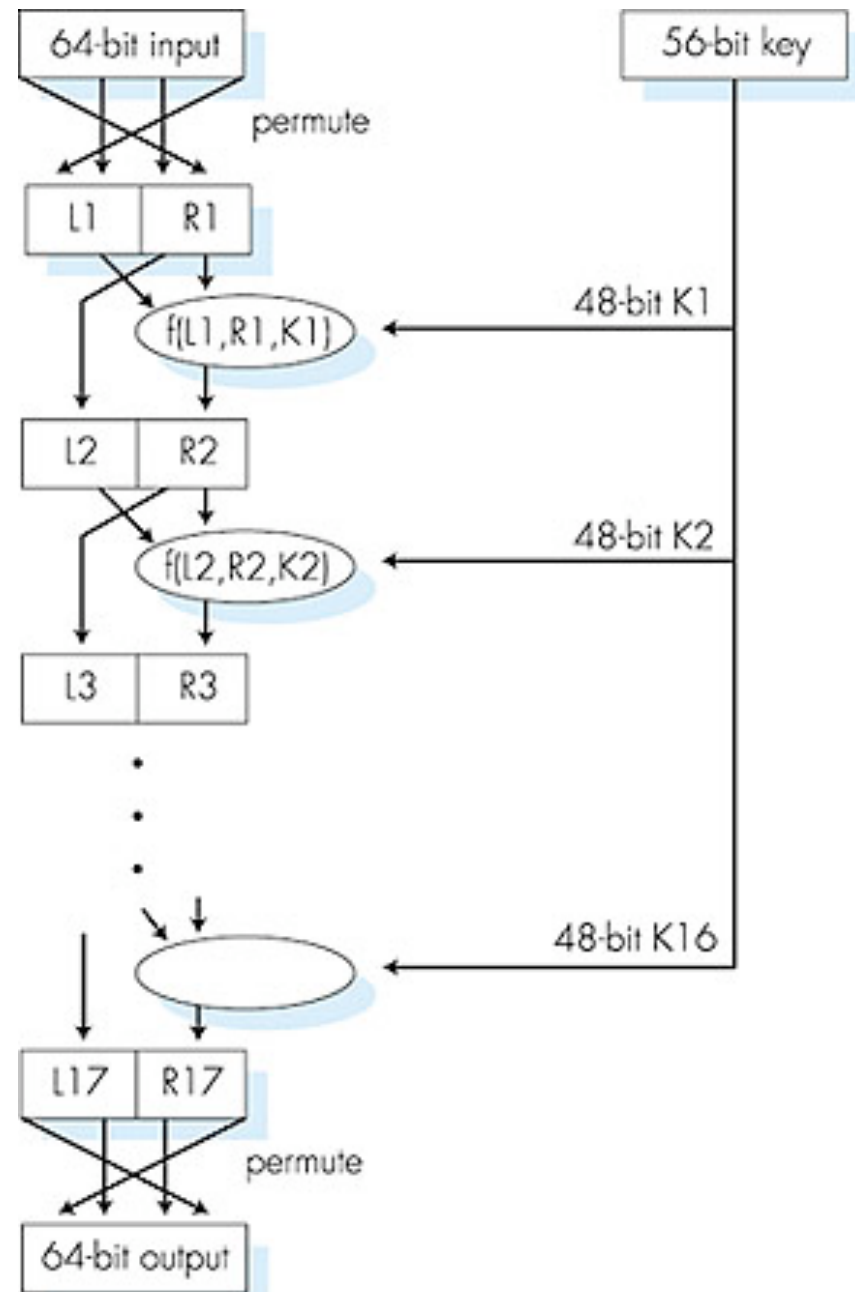

AES: Advanced Encryption Standard

- ❑ new (Nov. 2001) symmetric-key NIST standard, replacing DES
- ❑ processes data in 128 bit blocks
- ❑ 128, 192, or 256 bit keys
- ❑ brute force decryption (try each key) taking 1 sec on DES, takes 149 trillion years for AES

Public Key Cryptography

symmetric key crypto

- ❑ requires sender, receiver know shared secret key
- ❑ Q: how to agree on key in first place (particularly if never "met")?

public key cryptography

- ❑ radically different approach [Diffie-Hellman76, RSA78]
- ❑ sender, receiver do *not* share secret key
- ❑ *public* encryption key known to *all*
- ❑ *private* decryption key known only to receiver

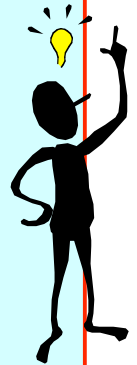

Public key cryptography

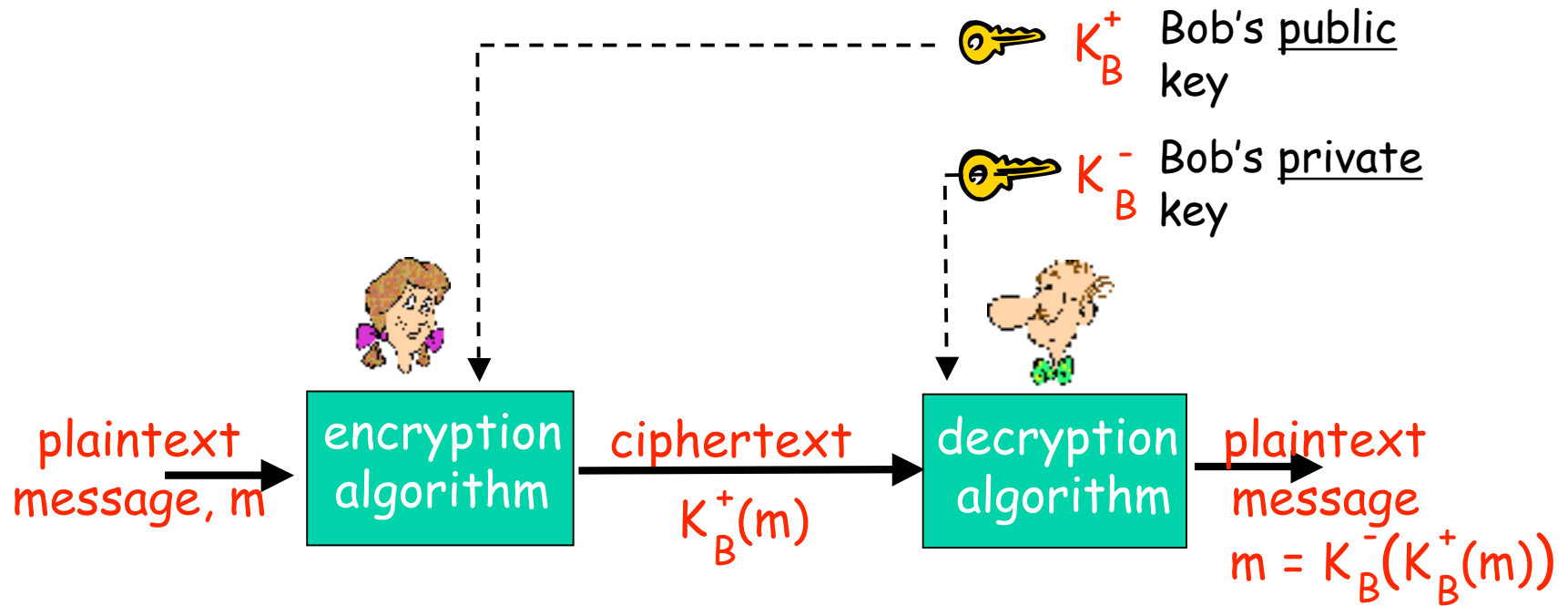

Public key encryption algorithms

Requirements:

① need $K_B^+(\cdot)$ and $K_B^-(\cdot)$ such that

$$K_B^-(K_B^+(m)) = m$$

② given public key K_B^+ , it should be impossible to compute private key K_B^-

RSA: Rivest, Shamir, Adelson algorithm

Prerequisite: modular arithmetic

□ $x \bmod n$ = remainder of x when divide by n

□ Facts:

$$[(a \bmod n) + (b \bmod n)] \bmod n = (a+b) \bmod n$$

$$[(a \bmod n) - (b \bmod n)] \bmod n = (a-b) \bmod n$$

$$[(a \bmod n) * (b \bmod n)] \bmod n = (a*b) \bmod n$$

□ Thus

$$(a \bmod n)^d \bmod n = a^d \bmod n$$

□ Example: $x=14, n=10, d=2$:

$$(x \bmod n)^d \bmod n = 4^2 \bmod 10 = 6$$

$$x^d = 14^2 = 196 \quad x^d \bmod 10 = 6$$

RSA: getting ready

- ❑ A message is a bit pattern.
- ❑ A bit pattern can be uniquely represented by an integer number.
- ❑ Thus encrypting a message is equivalent to encrypting a number.

Example

- ❑ $m = 10010001$. This message is uniquely represented by the decimal number 145.
- ❑ To encrypt m , we encrypt the corresponding number, which gives a new number (the cyphertext).

RSA: Creating public/private key pair

1. Choose two large prime numbers p, q .
(e.g., 1024 bits each)
2. Compute $n = pq, z = (p-1)(q-1)$
3. Choose e (with $e < n$) that has no common factors with z . (e, z are "relatively prime").
4. Choose d such that $ed-1$ is exactly divisible by z .
(in other words: $ed \bmod z = 1$).
5. Public key is (n, e) . Private key is (n, d) .

RSA: Encryption, decryption

0. Given (n,e) and (n,d) as computed above
1. To encrypt message $m (<n)$, compute
$$c = m^e \bmod n$$
2. To decrypt received bit pattern, c , compute
$$m = c^d \bmod n$$

Magic
happens!

$$m = \underbrace{(m^e \bmod n)}_c^d \bmod n$$

RSA example:

Bob chooses $p=5$, $q=7$. Then $n=35$, $z=24$.

$e=5$ (so e , z relatively prime).

$d=29$ (so $ed-1$ exactly divisible by z).

Encrypting 8-bit messages.

encrypt: bit pattern m m^e $c = m^e \bmod n$
 00001000 12 24832 17

decrypt: c c^d $m = c^d \bmod n$
 17 481968572106750915091411825223071697 12

Why does RSA work?

- Must show that $c^d \bmod n = m$
where $c = m^e \bmod n$
- Fact: for any x and y : $x^y \bmod n = x^{(y \bmod z)} \bmod n$
 - where $n = pq$ and $z = (p-1)(q-1)$
- Thus,
$$\begin{aligned} c^d \bmod n &= (m^e \bmod n)^d \bmod n \\ &= m^{ed} \bmod n \\ &= m^{(ed \bmod z)} \bmod n \\ &= m^1 \bmod n \\ &= m \end{aligned}$$

RSA: another important property

The following property will be *very* useful later:

$$\underbrace{K_B^-(K_B^+(m))}_{\text{use public key first, followed by private key}} = m = \underbrace{K_B^+(K_B^-(m))}_{\text{use private key first, followed by public key}}$$

use public key
first, followed
by private key

use private key
first, followed
by public key

Result is the same!

Why $K_B^-(K_B^+(m)) = m = K_B^+(K_B^-(m))$?

Follows directly from modular arithmetic:

$$\begin{aligned}(m^e \bmod n)^d \bmod n &= m^{ed} \bmod n \\ &= m^{de} \bmod n \\ &= (m^d \bmod n)^e \bmod n\end{aligned}$$

Why is RSA Secure?

- ❑ Suppose you know Bob's public key (n,e) . How hard is it to determine d ?
- ❑ Essentially need to find factors of n without knowing the two factors p and q .
- ❑ Fact: factoring a big number is hard.

Generating RSA keys

- ❑ Have to find big primes p and q
- ❑ Approach: make good guess then apply testing rules (see Kaufman)

Session keys

- ❑ Exponentiation is computationally intensive
- ❑ DES is at least 100 times faster than RSA

Session key, K_S

- ❑ Bob and Alice use RSA to exchange a symmetric key K_S
- ❑ Once both have K_S , they use symmetric key cryptography

Chapter 8 roadmap

8.1 What is network security?

8.2 Principles of cryptography

8.3 **Message integrity**

8.4 Securing e-mail

8.5 Securing TCP connections: SSL

8.6 Network layer security: IPsec

8.7 Securing wireless LANs

8.8 Operational security: firewalls and IDS

Message Integrity

- Allows communicating parties to verify that received messages are authentic.
 - Content of message has not been altered
 - Source of message is who/what you think it is
 - Message has not been replayed
 - Sequence of messages is maintained
- Let's first talk about message digests

Message Digests

- Function $H()$ that takes as input an arbitrary length message and outputs a fixed-length string: "message signature"
- Note that $H()$ is a many-to-1 function
- $H()$ is often called a "hash function"

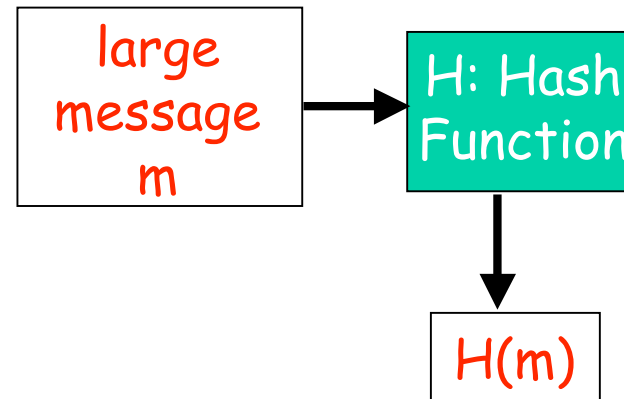

- Desirable properties:
 - Easy to calculate
 - Irreversibility: Can't determine m from $H(m)$
 - Collision resistance: Computationally difficult to produce m and m' such that $H(m) = H(m')$
 - Seemingly random output

Internet checksum: poor message digest

Internet checksum has some properties of hash function:

- ➔ produces fixed length digest (16-bit sum) of input
- ➔ is many-to-one
- ❑ But given message with given hash value, it is easy to find another message with same hash value.
- ❑ Example: Simplified checksum: add 4-byte chunks at a time:

<u>message</u>	<u>ASCII format</u>		<u>message</u>	<u>ASCII format</u>
I O U 1	49 4F 55 31		I O U <u>9</u>	49 4F 55 <u>39</u>
0 0 . 9	30 30 2E 39		0 0 . <u>1</u>	30 30 2E <u>31</u>
9 B O B	39 42 D2 42		9 B O B	39 42 D2 42
	<u>B2 C1 D2 AC</u>	different messages		<u>B2 C1 D2 AC</u>
		but identical checksums!		

Hash Function Algorithms

- ❑ MD5 hash function widely used (RFC 1321)
 - computes 128-bit message digest in 4-step process.
- ❑ SHA-1 is also used.
 - US standard [NIST, FIPS PUB 180-1]
 - 160-bit message digest

Message Authentication Code (MAC)

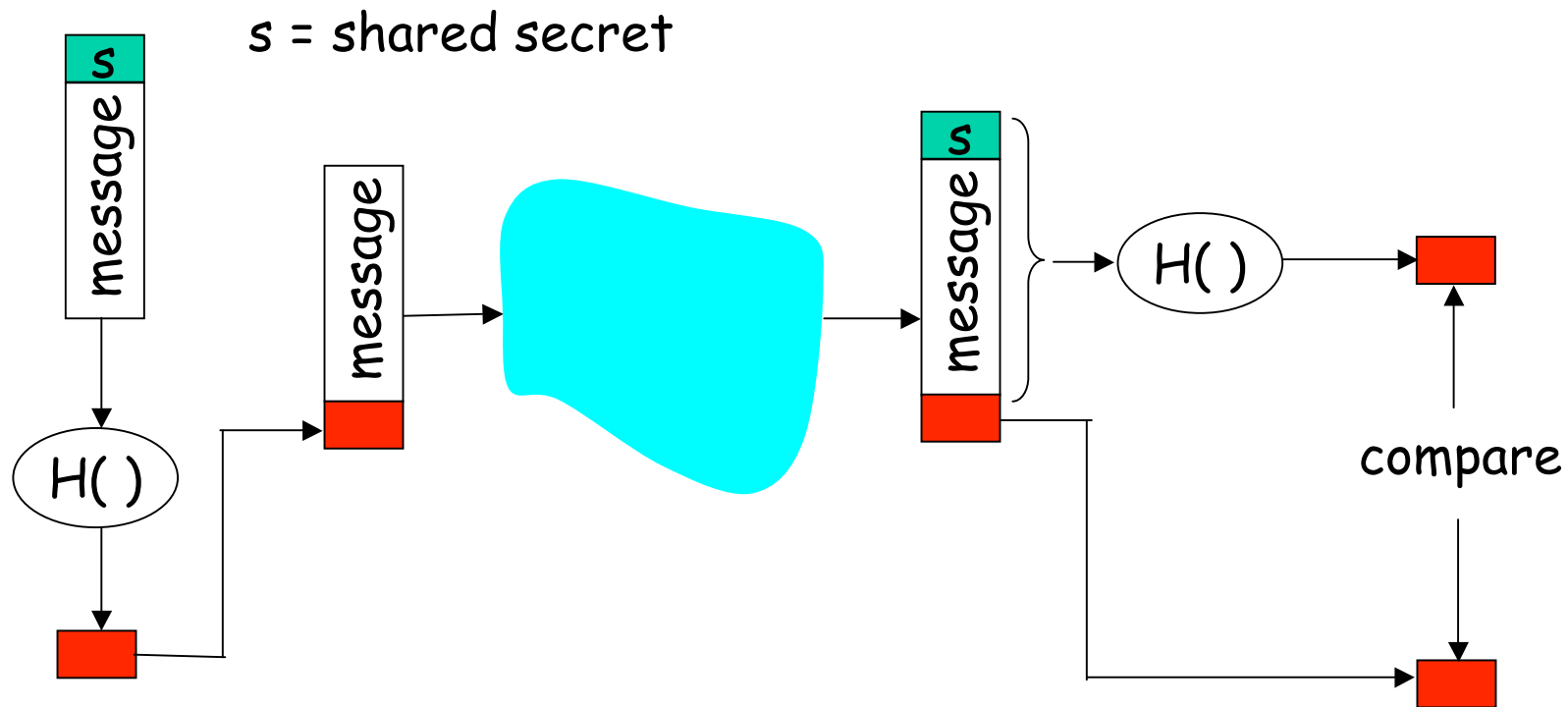

- ❑ *Authenticates sender*
- ❑ *Verifies message integrity*
- ❑ No encryption !
- ❑ Also called "keyed hash"
- ❑ Notation: $MD_m = H(s||m)$; send $m||MD_m$

HMAC

- ❑ Popular MAC standard
 - ❑ Addresses some subtle security flaws
1. Concatenates secret to front of message.
 2. Hashes concatenated message
 3. Concatenates the secret to front of digest
 4. Hashes the combination again.

Example: OSPF

- ❑ Recall that OSPF is an intra-AS routing protocol
- ❑ Each router creates map of entire AS (or area) and runs shortest path algorithm over map.
- ❑ Router receives link-state advertisements (LSAs) from all other routers in AS.

Attacks:

- ❑ Message insertion
- ❑ Message deletion
- ❑ Message modification

- ❑ How do we know if an OSPF message is authentic?

OSPF Authentication

- ❑ Within an Autonomous System, routers send OSPF messages to each other.
- ❑ OSPF provides authentication choices
 - No authentication
 - Shared password: inserted in clear in 64-bit authentication field in OSPF packet
 - Cryptographic hash
- ❑ Cryptographic hash with MD5
 - 64-bit authentication field includes 32-bit sequence number
 - MD5 is run over a concatenation of the OSPF packet and shared secret key
 - MD5 hash then appended to OSPF packet; encapsulated in IP datagram

End-point authentication

- ❑ Want to be sure of the originator of the message - *end-point authentication*.
- ❑ Assuming Alice and Bob have a shared secret, will MAC provide end-point authentication.
 - We do know that Alice created the message.
 - But did she send it?

Playback attack

MAC =
 $f(\text{msg}, s)$

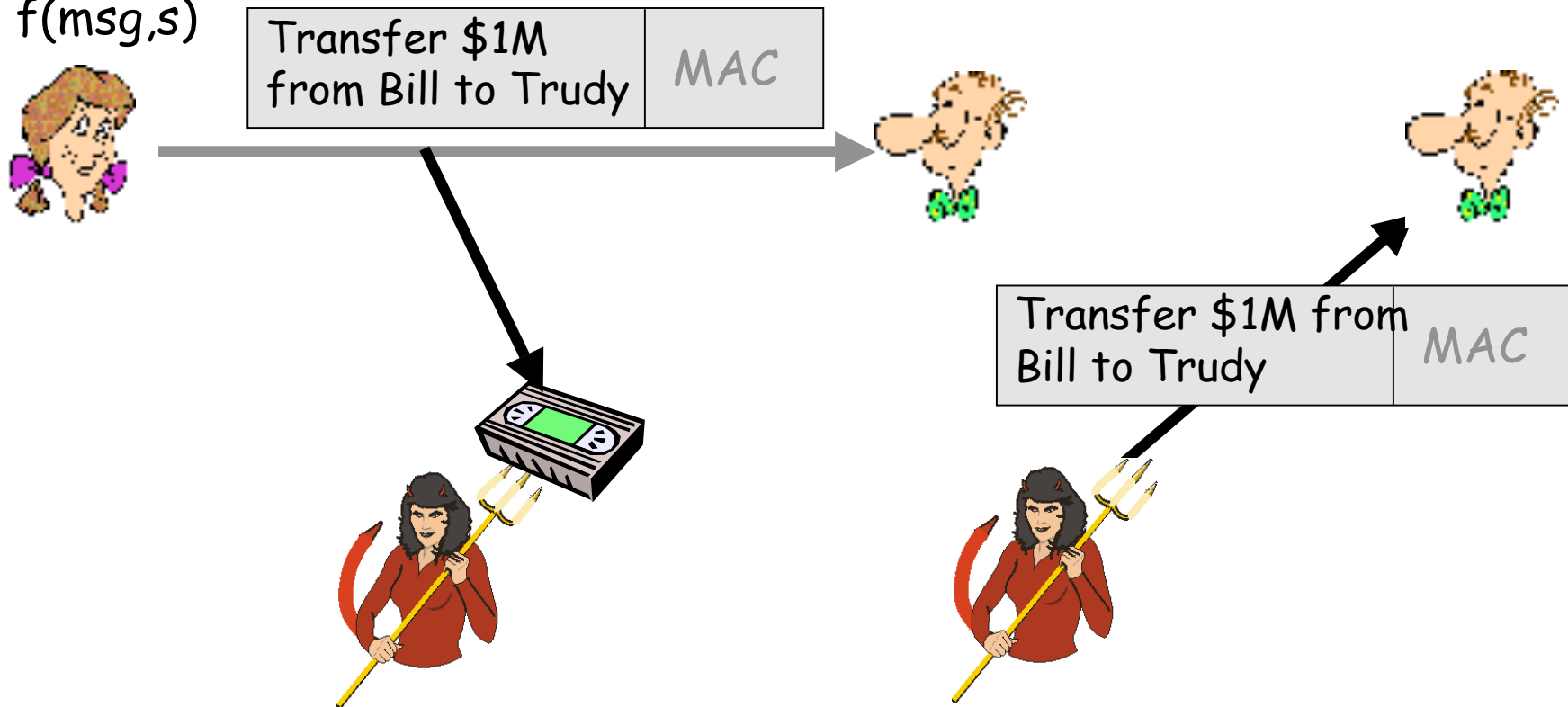

Defending against playback attack: nonce

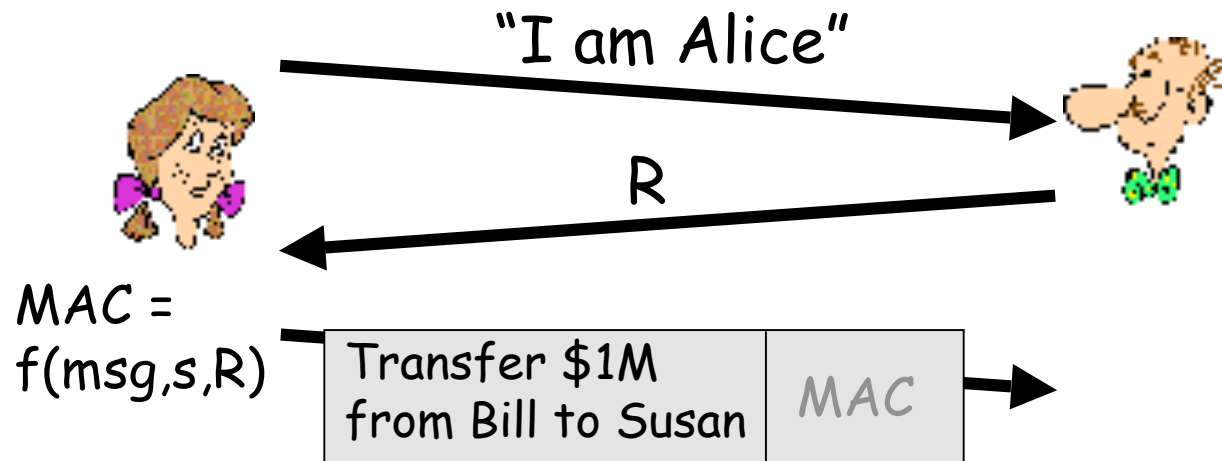

Digital Signatures

Cryptographic technique analogous to hand-written signatures.

- ❑ sender (Bob) digitally signs document, establishing he is document owner/creator.
- ❑ Goal is similar to that of a MAC, except now use public-key cryptography
- ❑ **verifiable, nonforgeable**: recipient (Alice) can prove to someone that Bob, and no one else (including Alice), must have signed document

Digital Signatures

Simple digital signature for message m :

- Bob signs m by encrypting with his private key K_B^- , creating "signed" message, $K_B^-(m)$

Bob's message, m

Dear Alice
Oh, how I have missed you. I think of you all the time! ... (blah blah blah)
Bob

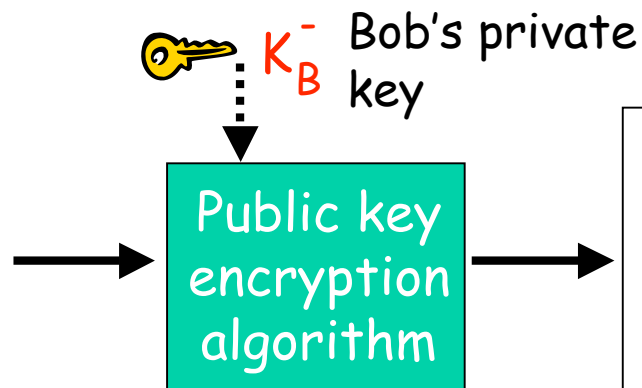

$K_B^-(m)$

Bob's message, m , signed (encrypted) with his private key

Digital signature = signed message digest

Bob sends digitally signed message:

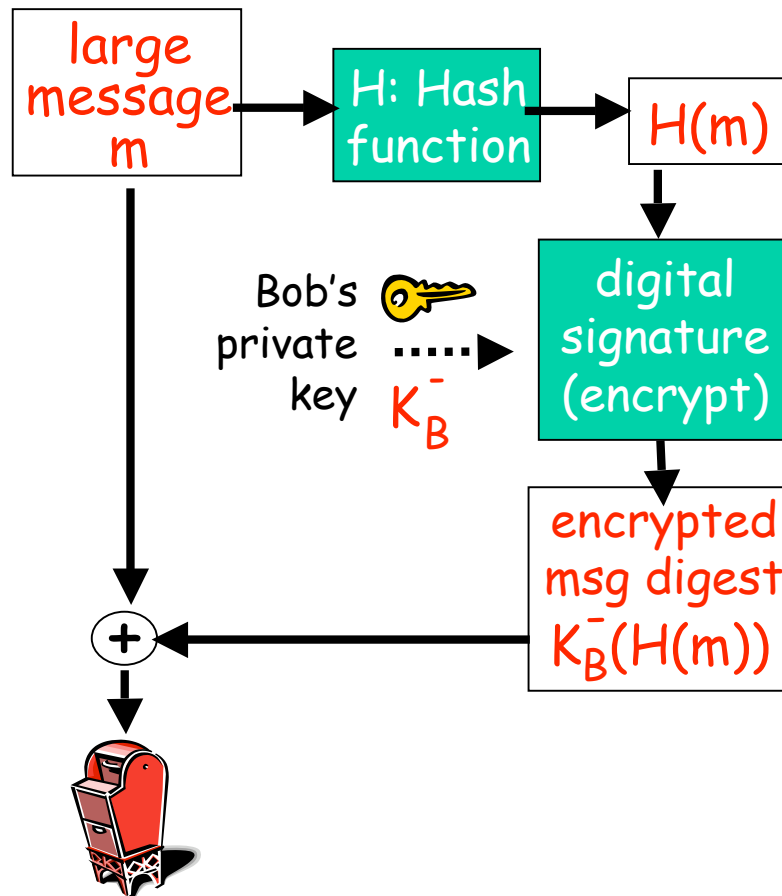

Alice verifies signature and integrity of digitally signed message:

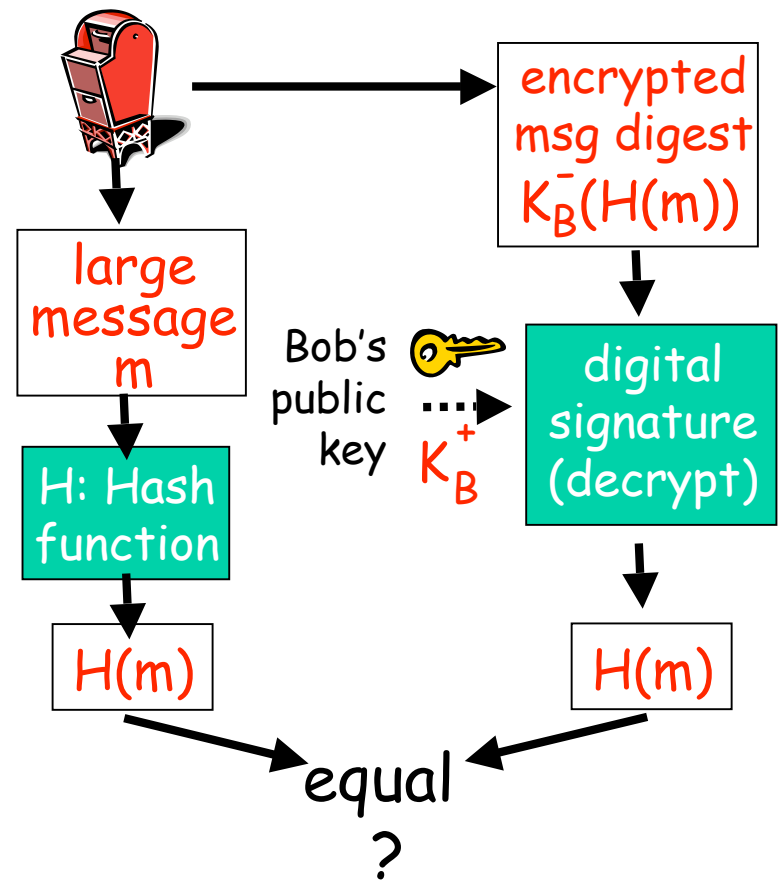

Digital Signatures (more)

- Suppose Alice receives msg m , digital signature $K_B^-(m)$
- Alice verifies m signed by Bob by applying Bob's public key K_B^+ to $K_B^-(m)$ then checks $K_B^+(K_B^-(m)) = m$.
- If $K_B^+(K_B^-(m)) = m$, whoever signed m must have used Bob's private key.

Alice thus verifies that:

- Bob signed m .
- No one else signed m .
- Bob signed m and not m' .

Non-repudiation:

- ✓ Alice can take m , and signature $K_B^-(m)$ to court and prove that Bob signed m .

Public-key certification

- Motivation: Trudy plays pizza prank on Bob
 - Trudy creates e-mail order:
Dear Pizza Store, Please deliver to me four pepperoni pizzas. Thank you, Bob
 - Trudy signs order with her private key
 - Trudy sends order to Pizza Store
 - Trudy sends to Pizza Store her public key, but says it's Bob's public key.
 - Pizza Store verifies signature; then delivers four pizzas to Bob.
 - Bob doesn't even like Pepperoni

Certification Authorities

- ❑ **Certification authority (CA):** binds public key to particular entity, E.
- ❑ E (person, router) registers its public key with CA.
 - E provides "proof of identity" to CA.
 - CA creates certificate binding E to its public key.
 - certificate containing E's public key digitally signed by CA - CA says "this is E's public key"

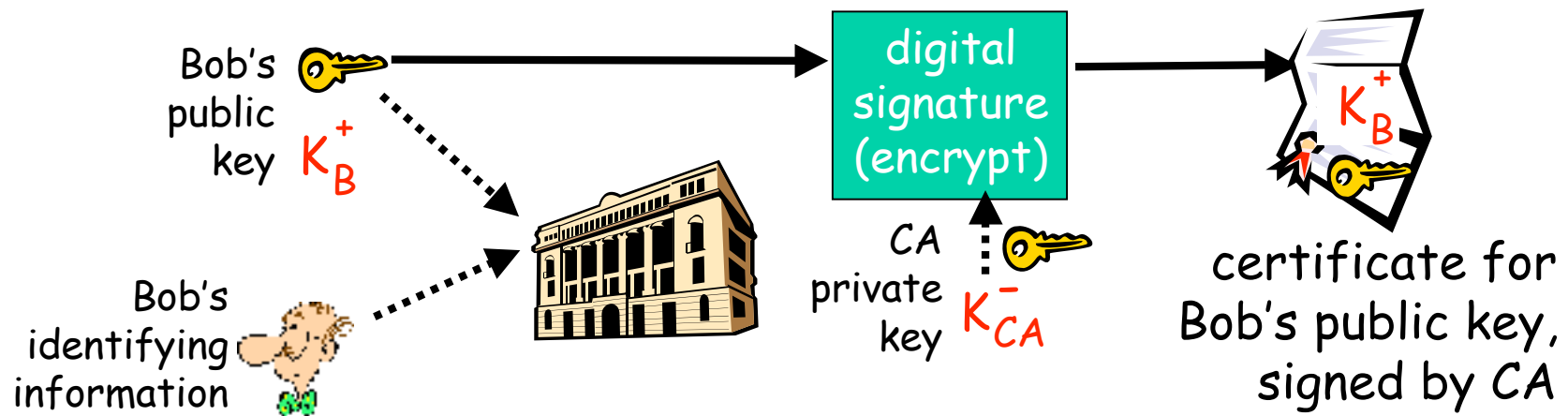

Certification Authorities

- When Alice wants Bob's public key:
 - gets Bob's certificate (Bob or elsewhere).
 - apply CA's public key to Bob's certificate, get Bob's public key

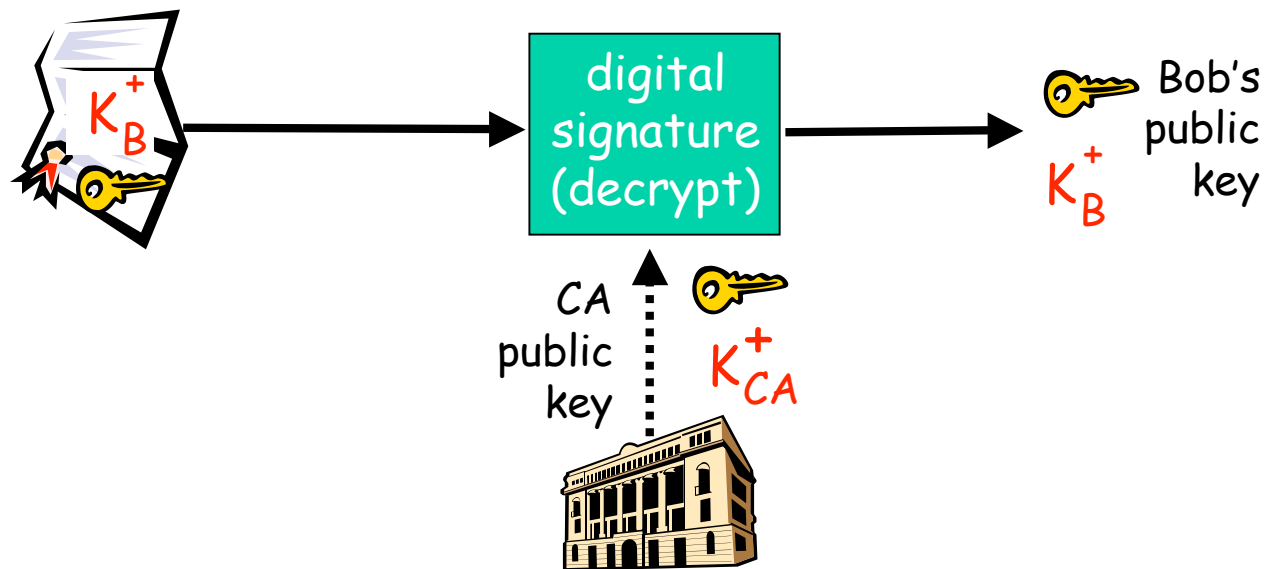

Certificates: summary

- ❑ Primary standard X.509 (RFC 2459)
- ❑ Certificate contains:
 - Issuer name
 - Entity name, address, domain name, etc.
 - Entity's public key
 - Digital signature (signed with issuer's private key)
- ❑ Public-Key Infrastructure (PKI)
 - Certificates and certification authorities
 - Often considered "heavy"

Chapter 8 roadmap

8.1 What is network security?

8.2 Principles of cryptography

8.3 Message integrity

8.4 Securing e-mail

8.5 Securing TCP connections: SSL

8.6 Network layer security: IPsec

8.7 Securing wireless LANs

8.8 Operational security: firewalls and IDS

Secure e-mail

- Alice wants to send confidential e-mail, m , to Bob.

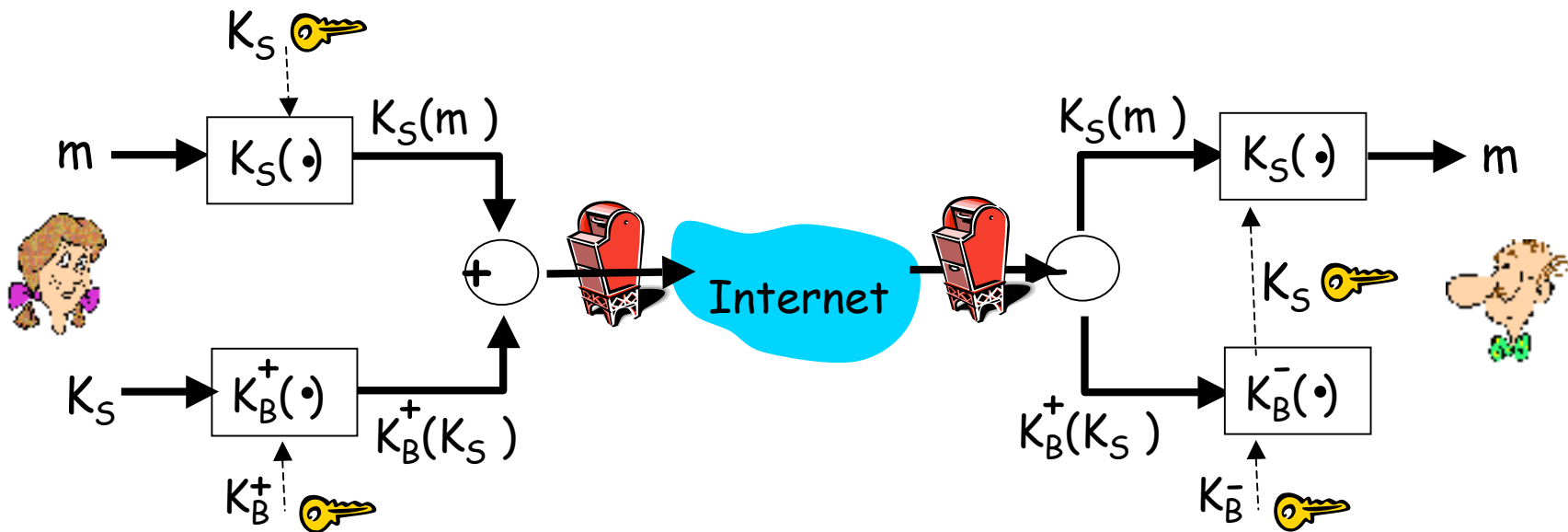

Alice:

- generates random *symmetric* private key, K_S .
- encrypts message with K_S (for efficiency)
- also encrypts K_S with Bob's public key.
- sends both $K_S(m)$ and $K_B^+(K_S)$ to Bob.

Secure e-mail

- Alice wants to send confidential e-mail, m , to Bob.

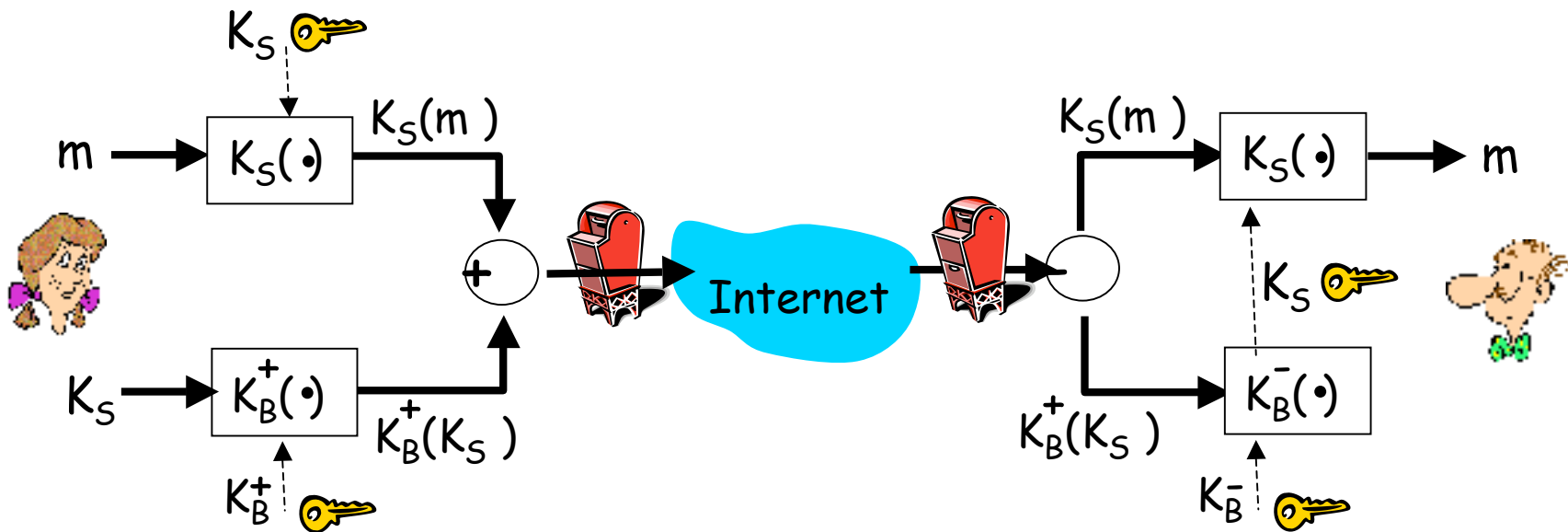

Bob:

- uses his private key to decrypt and recover K_S
- uses K_S to decrypt $K_S(m)$ to recover m

Secure e-mail (continued)

- Alice wants to provide sender authentication and message integrity.

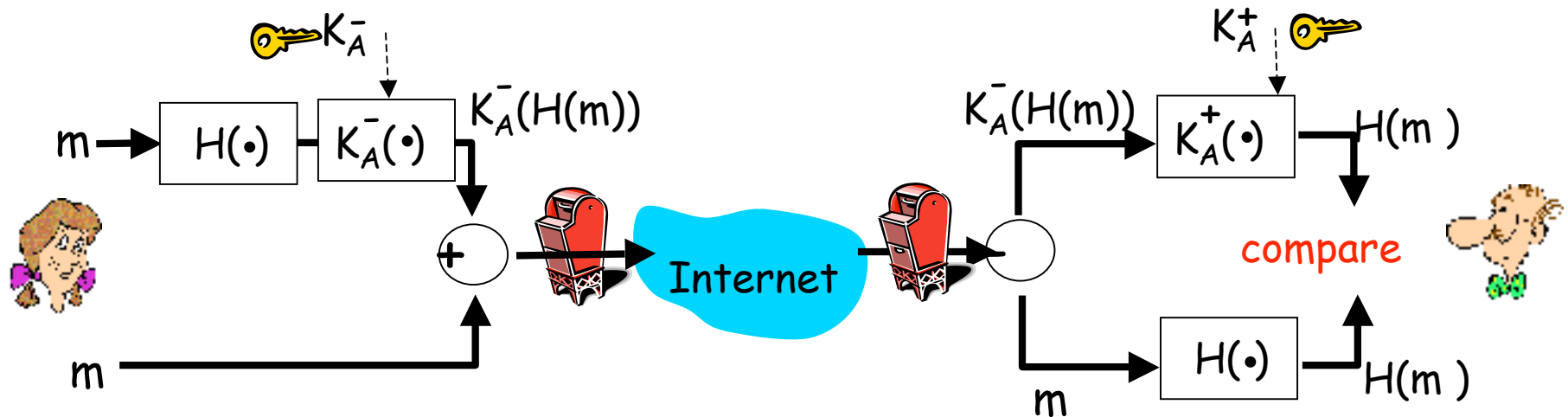

- Alice digitally signs message.
- sends both message (in the clear) and digital signature.

Secure e-mail (continued)

- Alice wants to provide secrecy, sender authentication, message integrity.

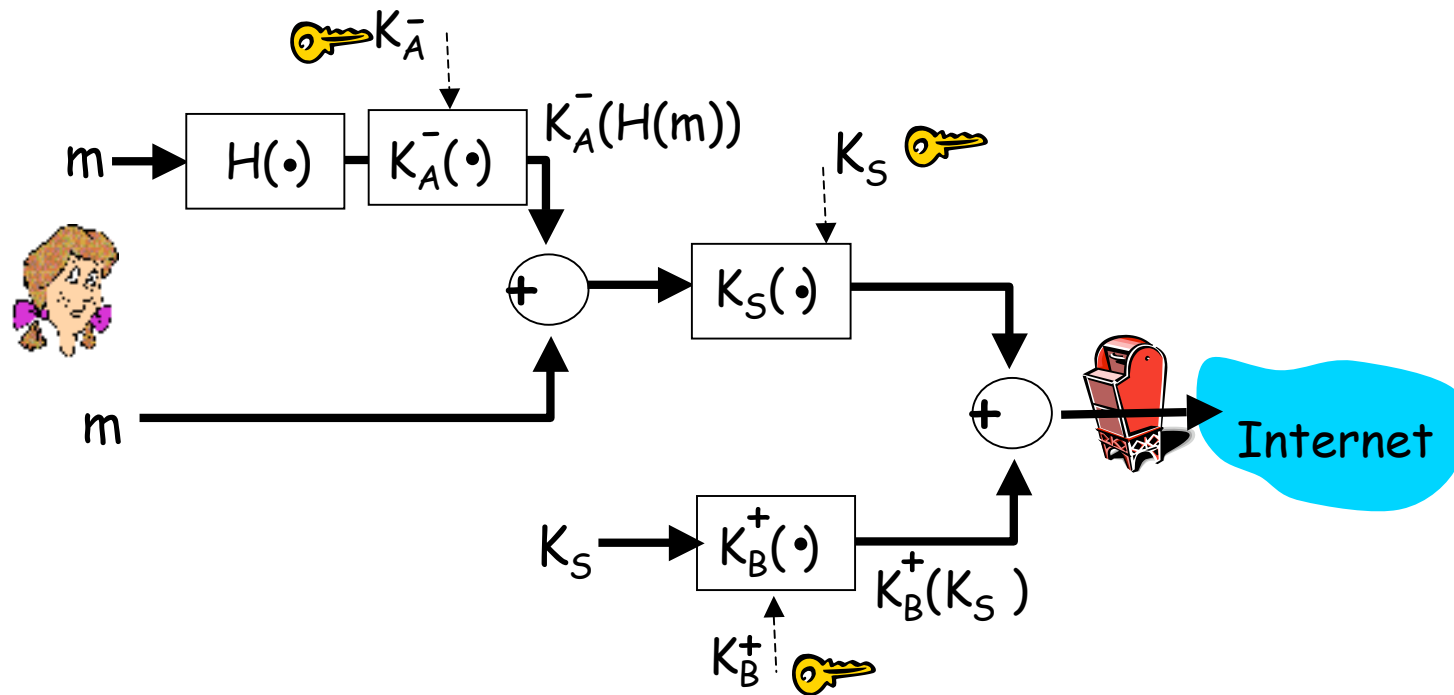

Alice uses three keys: her private key, Bob's public key, newly created symmetric key

Chapter 8 roadmap

8.1 What is network security?

8.2 Principles of cryptography

8.3 Message integrity

8.4 Securing e-mail

8.5 Securing TCP connections: SSL

8.6 Network layer security: IPsec

8.7 Securing wireless LANs

8.8 Operational security: firewalls and IDS

SSL: Secure Sockets Layer

- ❑ Widely deployed security protocol
 - Supported by almost all browsers and web servers
 - https
 - Tens of billions \$ spent per year over SSL
- ❑ Originally designed by Netscape in 1993
- ❑ Number of variations:
 - TLS: transport layer security, RFC 2246
- ❑ Provides
 - Confidentiality
 - Integrity
 - Authentication
- ❑ Original goals:
 - Had Web e-commerce transactions in mind
 - Encryption (especially credit-card numbers)
 - Web-server authentication
 - Optional client authentication
 - Minimum hassle in doing business with new merchant
- ❑ Available to all TCP applications
 - Secure socket interface

SSL and TCP/IP

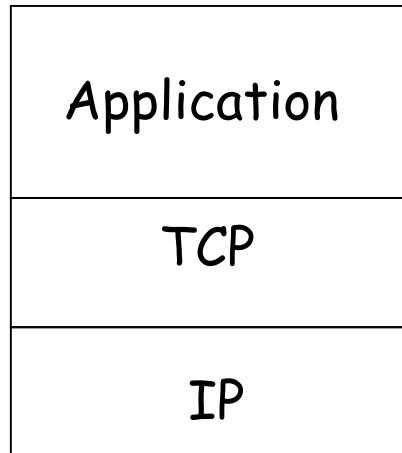

Normal Application

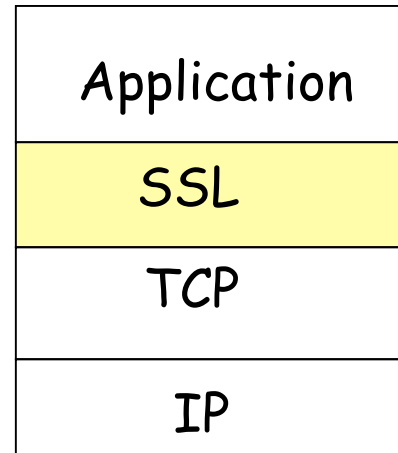

Application
with SSL

- SSL provides application programming interface (API) to applications
- C and Java SSL libraries/classes readily available

Could do something like PGP:

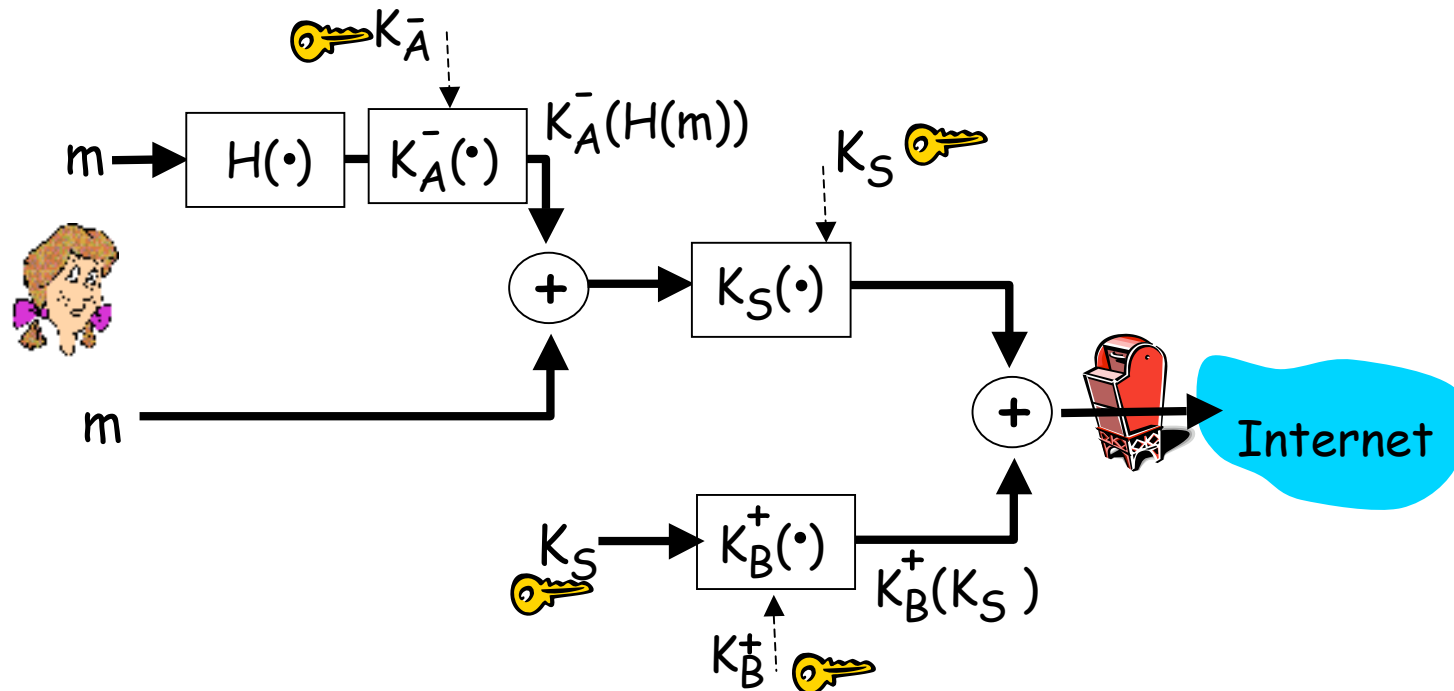

- But want to send byte streams & interactive data
- Want a set of secret keys for the entire connection
- Want certificate exchange part of protocol:
handshake phase

Toy SSL: a simple secure channel

- ❑ Handshake: Alice and Bob use their certificates and private keys to authenticate each other and exchange shared secret
- ❑ Key Derivation: Alice and Bob use shared secret to derive set of keys
- ❑ Data Transfer: Data to be transferred is broken up into a series of records
- ❑ Connection Closure: Special messages to securely close connection

Toy: A simple handshake

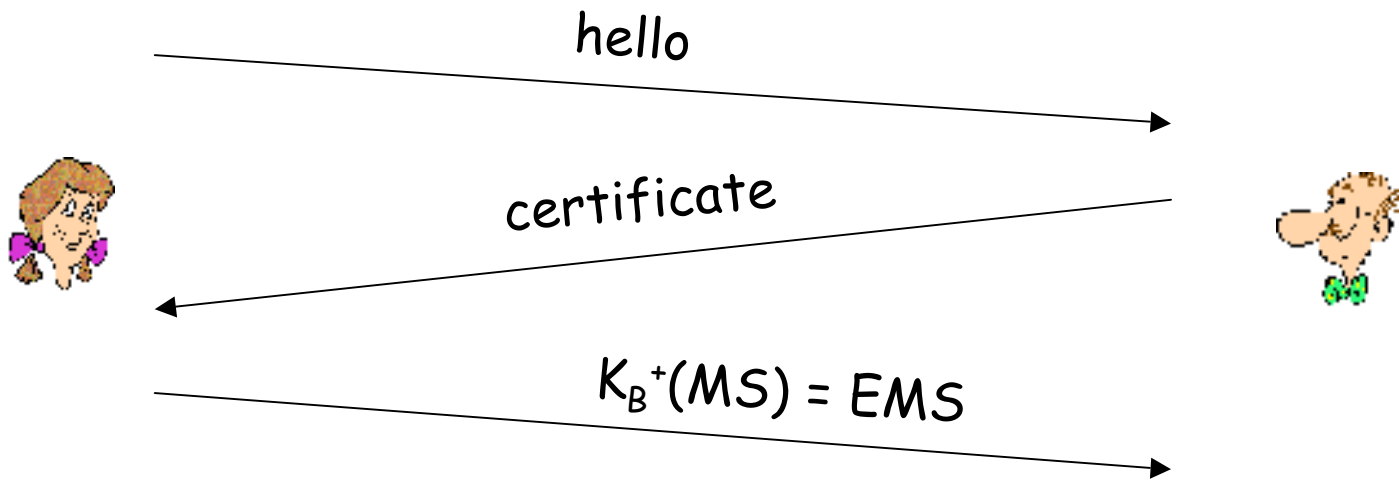

- ❑ MS = master secret
- ❑ EMS = encrypted master secret

Toy: Key derivation

- ❑ Considered bad to use same key for more than one cryptographic operation
 - Use different keys for message authentication code (MAC) and encryption
- ❑ Four keys:
 - K_c = encryption key for data sent from client to server
 - M_c = MAC key for data sent from client to server
 - K_s = encryption key for data sent from server to client
 - M_s = MAC key for data sent from server to client
- ❑ Keys derived from key derivation function (KDF)
 - Takes master secret and (possibly) some additional random data and creates the keys

Toy: Data Records

- ❑ Why not encrypt data in constant stream as we write it to TCP?
 - Where would we put the MAC? If at end, no message integrity until all data processed.
 - For example, with instant messaging, how can we do integrity check over all bytes sent before displaying?
- ❑ Instead, break stream in series of records
 - Each record carries a MAC
 - Receiver can act on each record as it arrives
- ❑ Issue: in record, receiver needs to distinguish MAC from data
 - Want to use variable-length records



Toy: Sequence Numbers

- ❑ Attacker can capture and replay record or re-order records
- ❑ Solution: put sequence number into MAC:
 - $MAC = MAC(M_x, \text{sequence} || \text{data})$
 - Note: no sequence number field
- ❑ Attacker could still replay all of the records
 - Use random nonce

Toy: Control information

- ❑ Truncation attack:
 - attacker forges TCP connection close segment
 - One or both sides thinks there is less data than there actually is.
- ❑ Solution: record types, with one type for closure
 - type 0 for data; type 1 for closure
- ❑ $MAC = MAC(M_x, \text{sequence} || \text{type} || \text{data})$



Toy SSL: summary



bob.com

encrypted

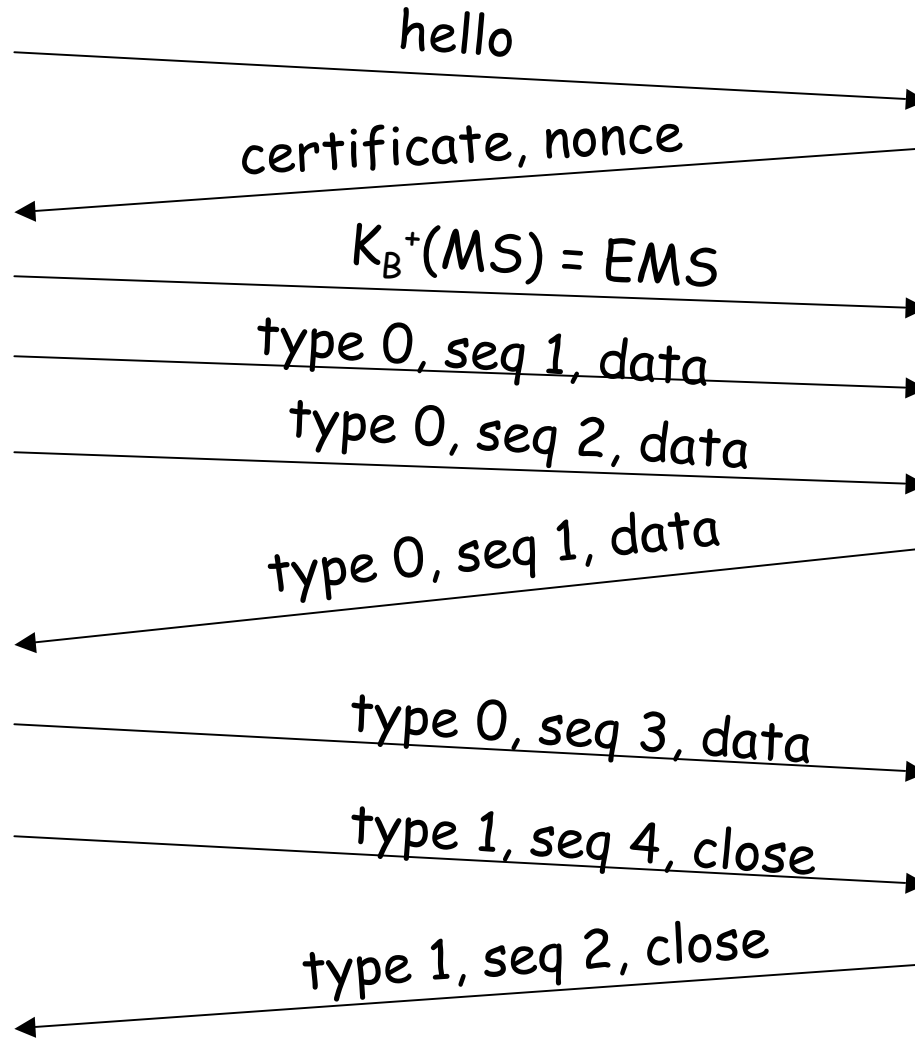

Toy SSL isn't complete

- ❑ How long are the fields?
- ❑ What encryption protocols?
- ❑ No negotiation
 - Allow client and server to support different encryption algorithms
 - Allow client and server to choose together specific algorithm before data transfer

Most common symmetric ciphers in SSL

- ❑ DES - Data Encryption Standard: block
- ❑ 3DES - Triple strength: block
- ❑ RC2 - Rivest Cipher 2: block
- ❑ RC4 - Rivest Cipher 4: stream

Public key encryption

- ❑ RSA

SSL Cipher Suite

- ❑ Cipher Suite
 - Public-key algorithm
 - Symmetric encryption algorithm
 - MAC algorithm
- ❑ SSL supports a variety of cipher suites
- ❑ Negotiation: client and server must agree on cipher suite
- ❑ Client offers choice; server picks one

Real SSL: Handshake (1)

Purpose

1. Server authentication
2. Negotiation: agree on crypto algorithms
3. Establish keys
4. Client authentication (optional)

Real SSL: Handshake (2)

1. Client sends list of algorithms it supports, along with client nonce
2. Server chooses algorithms from list; sends back: choice + certificate + server nonce
3. Client verifies certificate, extracts server's public key, generates `pre_master_secret`, encrypts with server's public key, sends to server
4. Client and server independently compute encryption and MAC keys from `pre_master_secret` and nonces
5. Client sends a MAC of all the handshake messages
6. Server sends a MAC of all the handshake messages

Real SSL: Handshaking (3)

Last 2 steps protect handshake from tampering

- ❑ Client typically offers range of algorithms, some strong, some weak
- ❑ Man-in-the middle could delete the stronger algorithms from list
- ❑ Last 2 steps prevent this
 - Last two messages are encrypted

Real SSL: Handshaking (4)

- ❑ Why the two random nonces?
- ❑ Suppose Trudy sniffs all messages between Alice & Bob.
- ❑ Next day, Trudy sets up TCP connection with Bob, sends the exact same sequence of records,
 - Bob (Amazon) thinks Alice made two separate orders for the same thing.
 - Solution: Bob sends different random nonce for each connection. This causes encryption keys to be different on the two days.
 - Trudy's messages will fail Bob's integrity check.

SSL Record Protocol

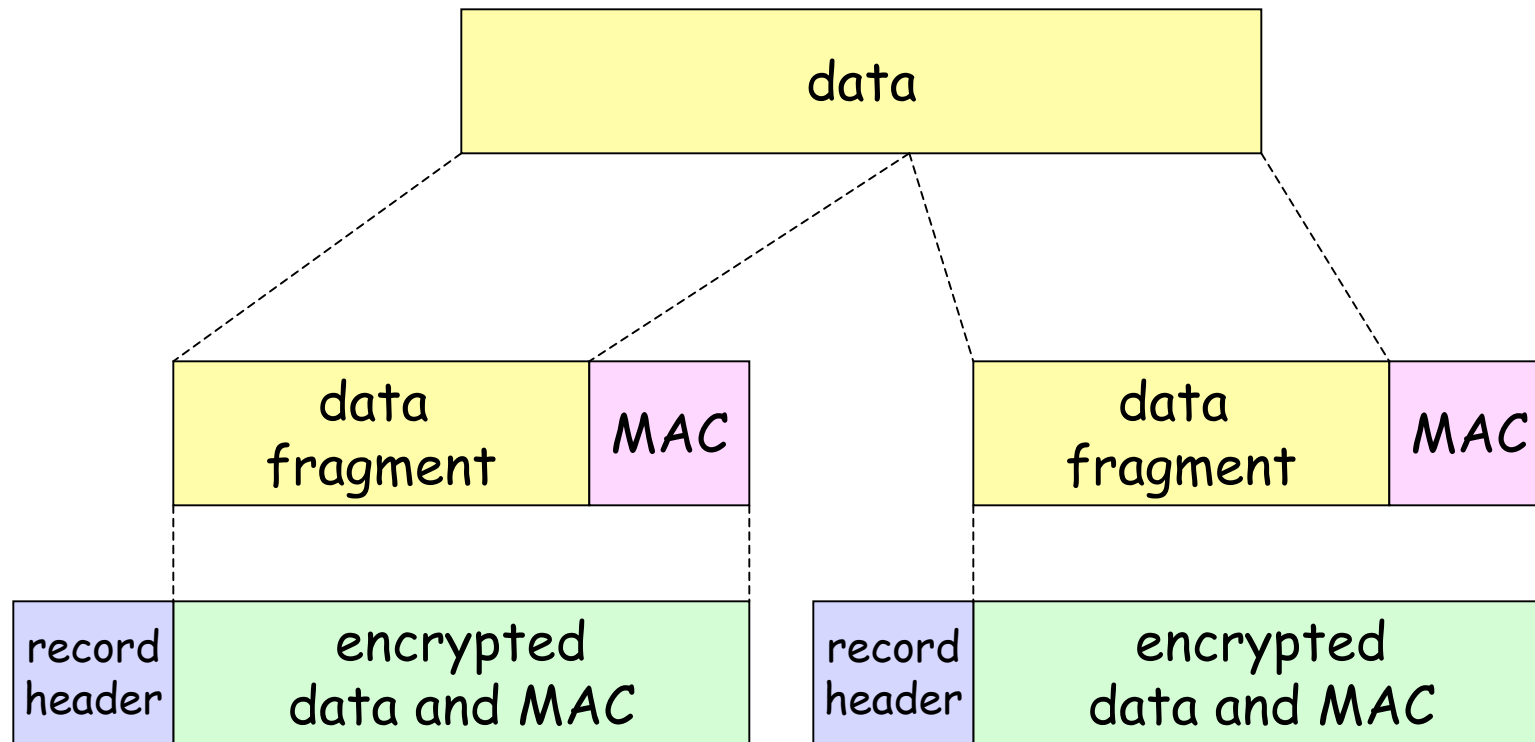

record header: content type; version; length

MAC: includes sequence number, MAC key M_x

Fragment: each SSL fragment 2^{14} bytes (~16 Kbytes)

SSL Record Format

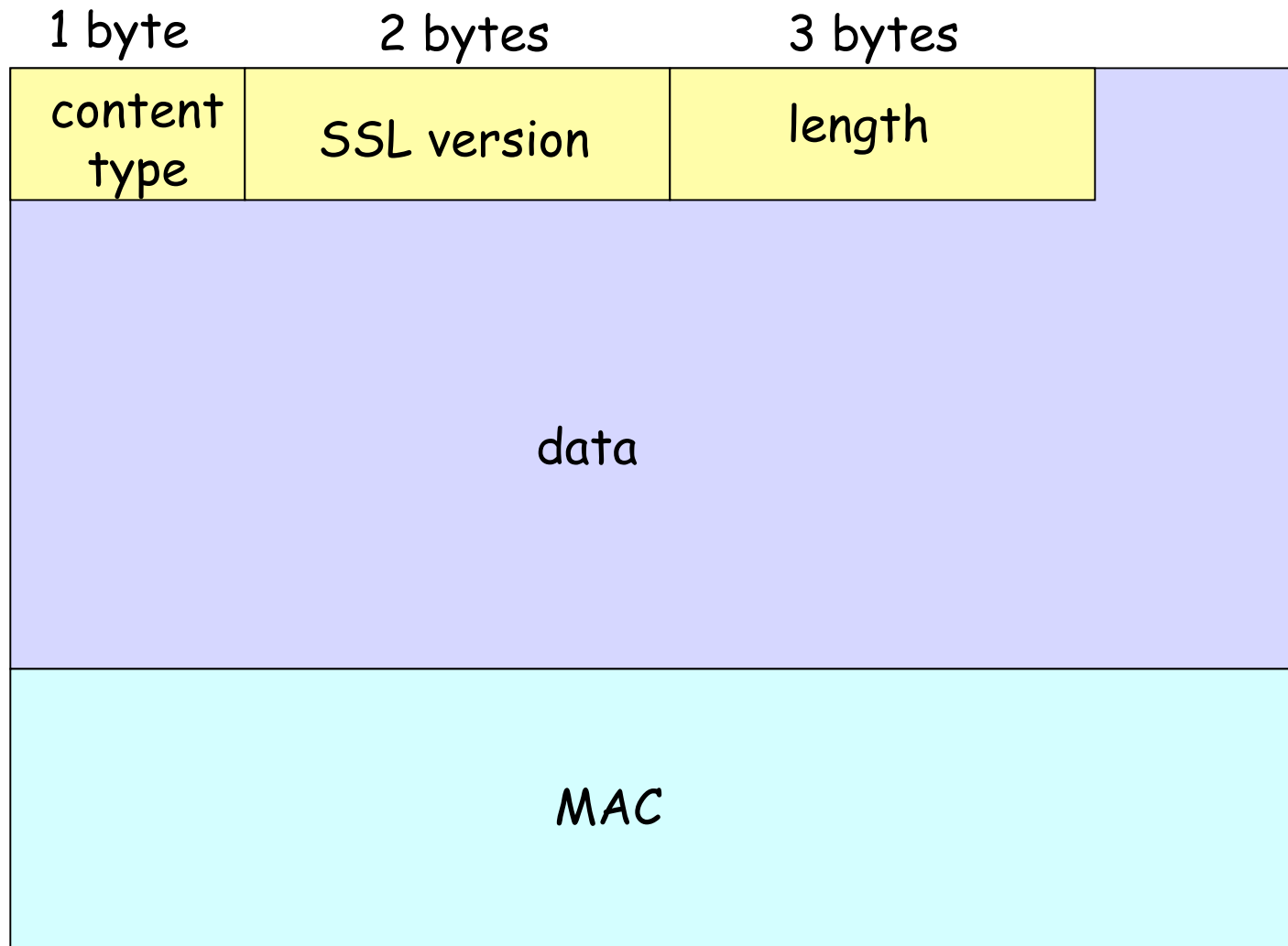

Data and MAC encrypted (symmetric algo)

Real Connection



Everything
henceforth
is encrypted

TCP Fin follow

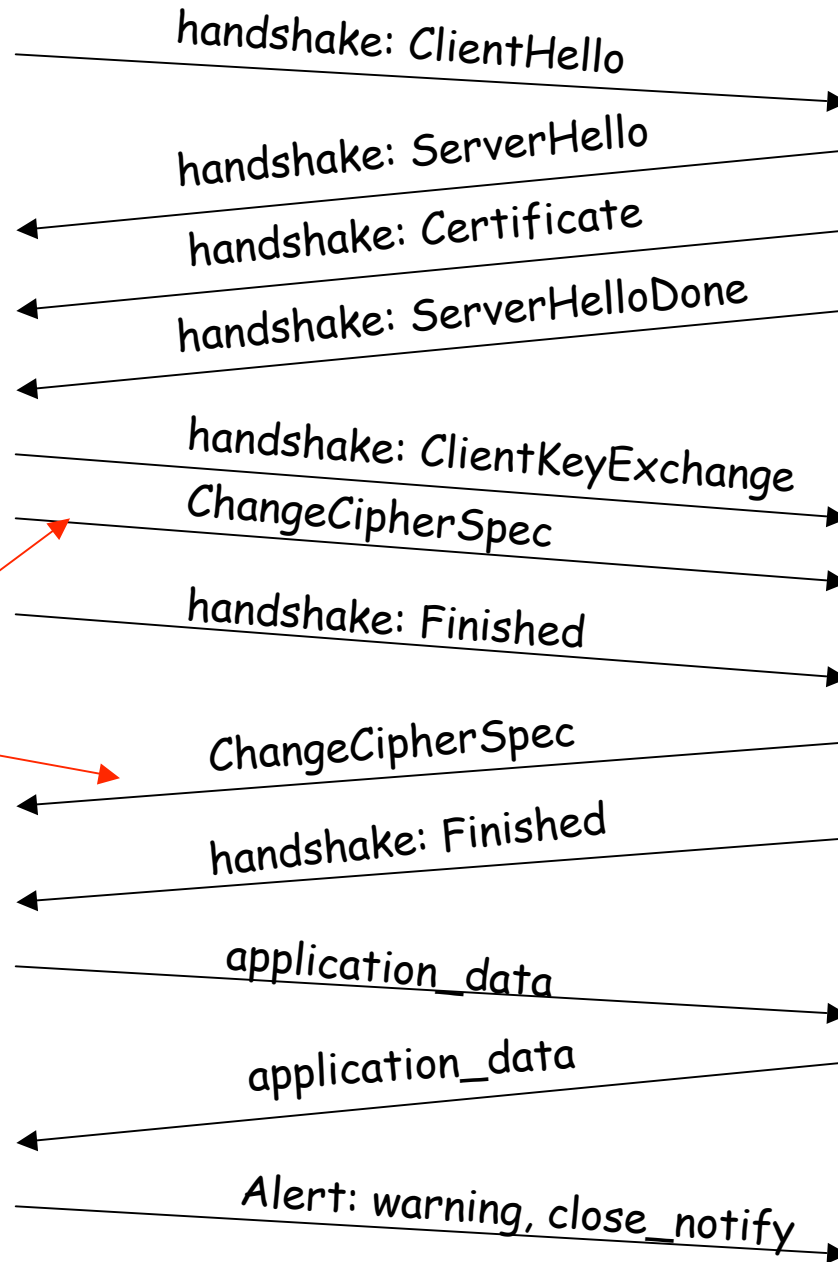

Key derivation

- ❑ Client nonce, server nonce, and pre-master secret input into pseudo random-number generator.
 - Produces master secret
- ❑ Master secret and new nonces inputted into another random-number generator: “key block”
 - Because of resumption: TBD
- ❑ Key block sliced and diced:
 - client MAC key
 - server MAC key
 - client encryption key
 - server encryption key
 - client initialization vector (IV)
 - server initialization vector (IV)

Chapter 8 roadmap

8.1 What is network security?

8.2 Principles of cryptography

8.3 Message integrity

8.4 Securing e-mail

8.5 Securing TCP connections: SSL

8.6 Network layer security: IPsec

8.7 Securing wireless LANs

8.8 Operational security: firewalls and IDS

What is confidentiality at the network-layer?

Between two network entities:

- ❑ Sending entity encrypts the payloads of datagrams. Payload could be:
 - TCP segment, UDP segment, ICMP message, OSPF message, and so on.
- ❑ All data sent from one entity to the other would be hidden:
 - Web pages, e-mail, P2P file transfers, TCP SYN packets, and so on.
- ❑ That is, "blanket coverage".

Virtual Private Networks (VPNs)

- ❑ Institutions often want private networks for security.
 - Costly! Separate routers, links, DNS infrastructure.
- ❑ With a VPN, institution's inter-office traffic is sent over public Internet instead.
 - But inter-office traffic is encrypted before entering public Internet

Virtual Private Network (VPN)

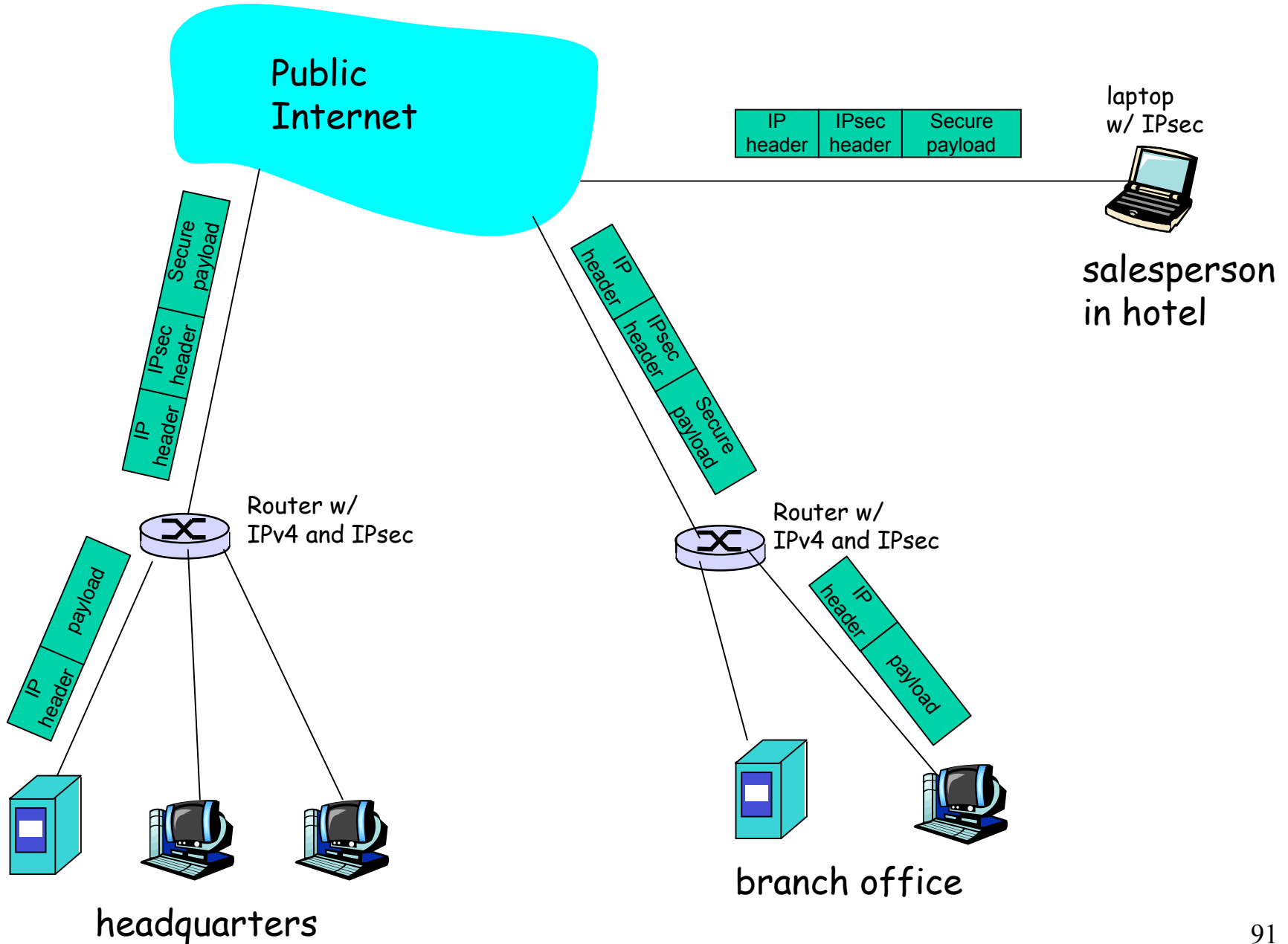

IPsec services

- ❑ Data integrity
- ❑ Origin authentication
- ❑ Replay attack prevention
- ❑ Confidentiality

- ❑ Two protocols providing different service models:
 - AH
 - ESP

IPsec Transport Mode

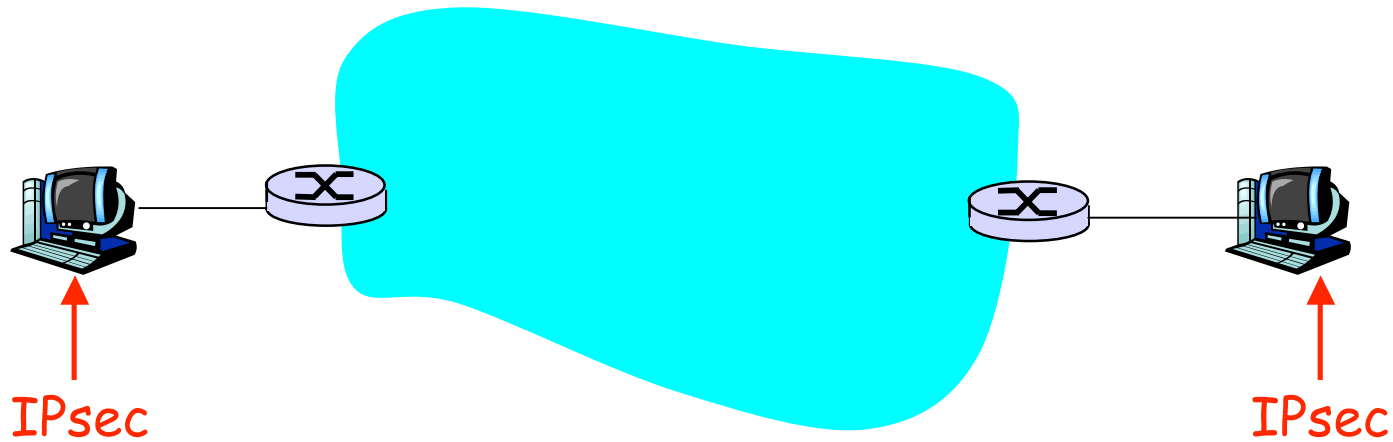

- ❑ IPsec datagram emitted and received by end-system.
- ❑ Protects upper level protocols

IPsec - tunneling mode (1)

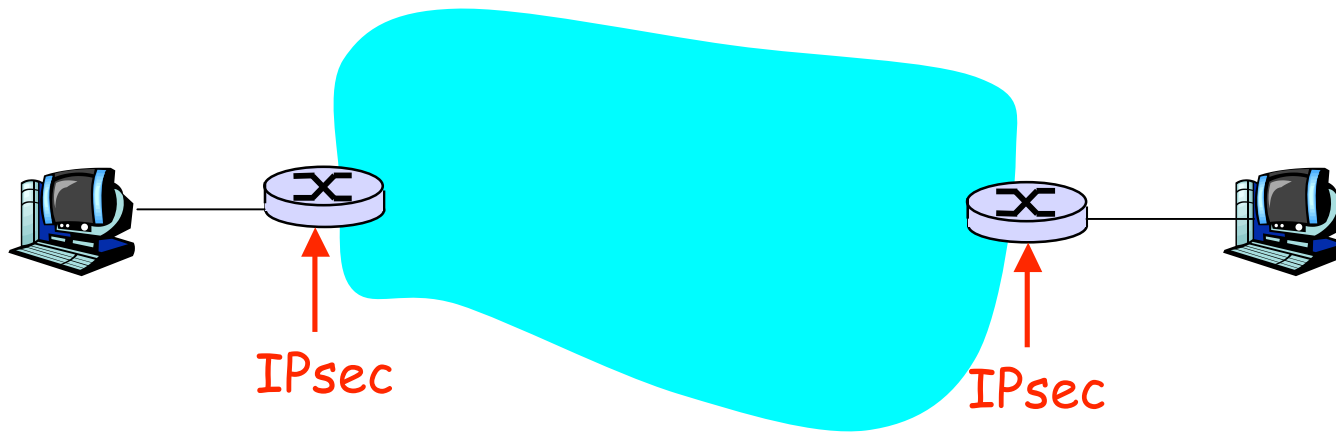

- End routers are IPsec aware. Hosts need not be.

IPsec - tunneling mode (2)

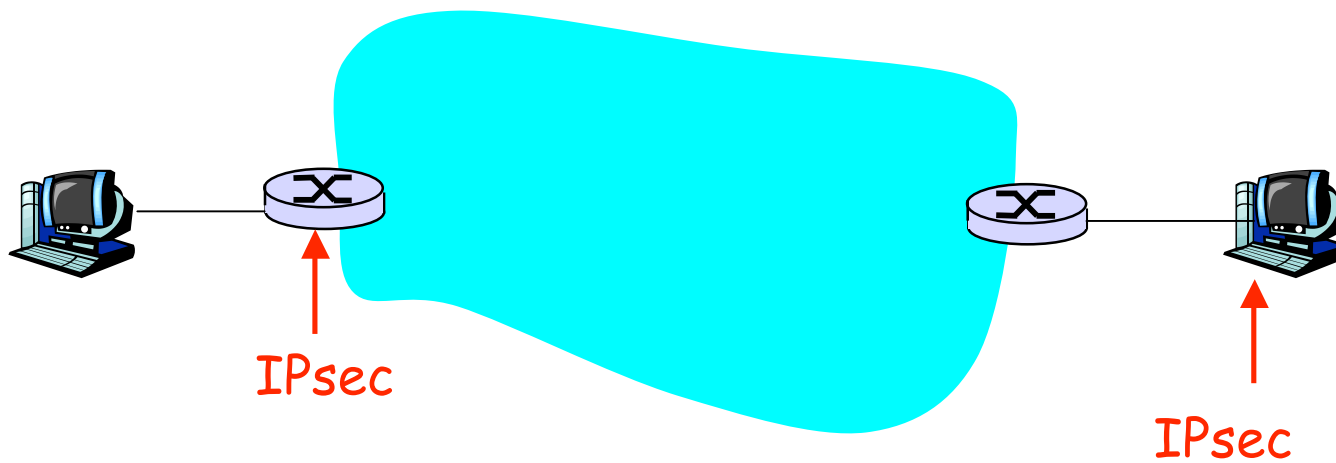

- Also tunneling mode.

Two protocols

- ❑ Authentication Header (AH) protocol
 - provides source authentication & data integrity but *not* confidentiality
- ❑ Encapsulation Security Protocol (ESP)
 - provides source authentication, data integrity, and *confidentiality*
 - more widely used than AH

Four combinations are possible!

Host mode with AH	Host mode with ESP
Tunnel mode with AH	Tunnel mode with ESP

Most common and
most important



Security associations (SAs)

- ❑ Before sending data, a virtual connection is established from sending entity to receiving entity.
- ❑ Called "security association (SA)"
 - SAs are simplex: for only one direction
- ❑ Both sending and receiving entities maintain *state information* about the SA
 - Recall that TCP endpoints also maintain state information.
 - IP is connectionless; IPsec is connection-oriented!
- ❑ How many SAs in VPN w/ headquarters, branch office, and n traveling salesperson?

Example SA from R1 to R2

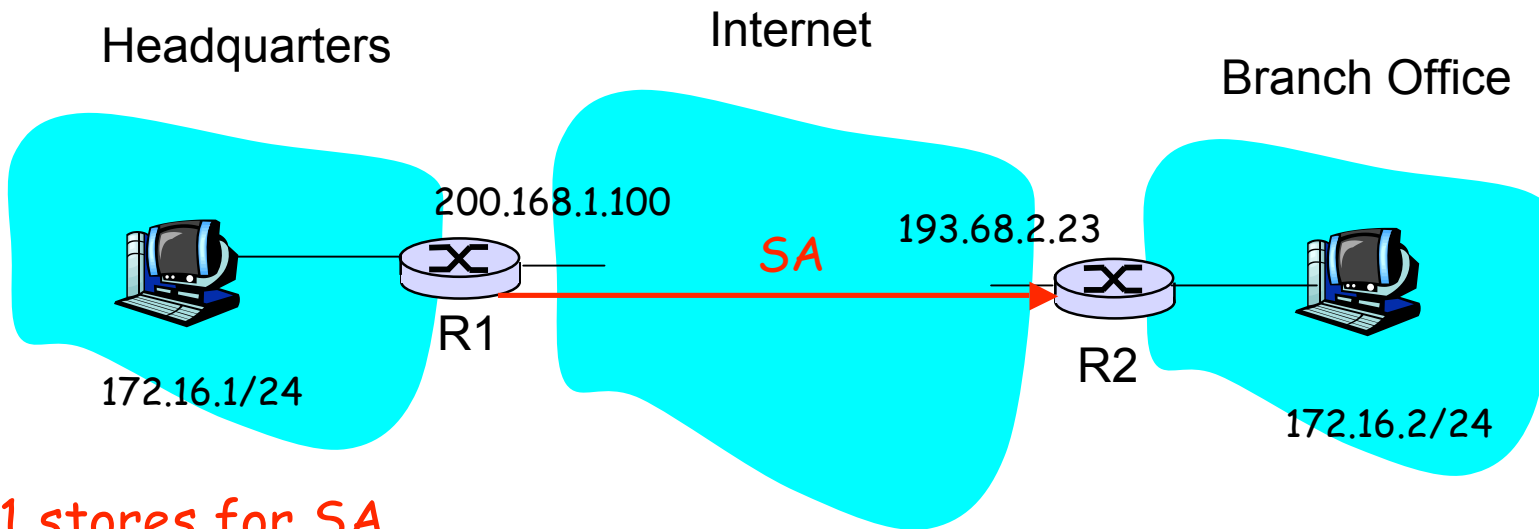

R1 stores for SA

- ❑ 32-bit identifier for SA: *Security Parameter Index (SPI)*
- ❑ the origin interface of the SA (200.168.1.100)
- ❑ destination interface of the SA (193.68.2.23)
- ❑ type of encryption to be used (for example, 3DES with CBC)
- ❑ encryption key
- ❑ type of integrity check (for example, HMAC with MD5)
- ❑ authentication key

Security Association Database (SAD)

- ❑ Endpoint holds state of its SAs in a SAD, where it can locate them during processing.
- ❑ With n salespersons, $2 + 2n$ SAs in R1's SAD
- ❑ When sending IPsec datagram, R1 accesses SAD to determine how to process datagram.
- ❑ When IPsec datagram arrives to R2, R2 examines SPI in IPsec datagram, indexes SAD with SPI, and processes datagram accordingly.

IPsec datagram

Focus for now on tunnel mode with ESP

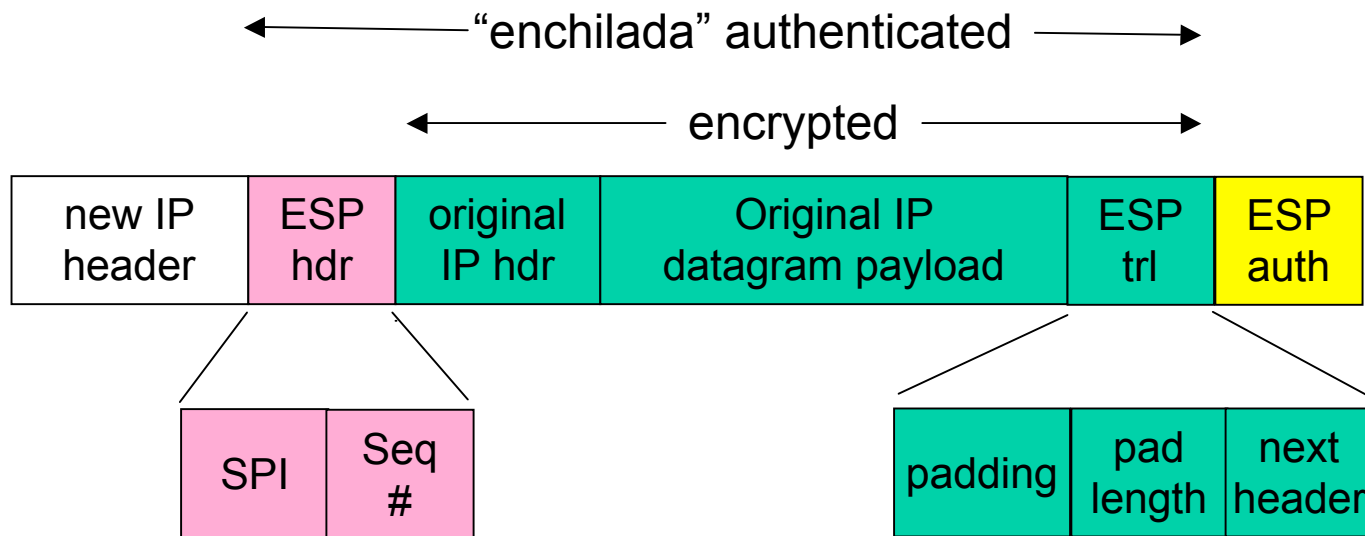

What happens?

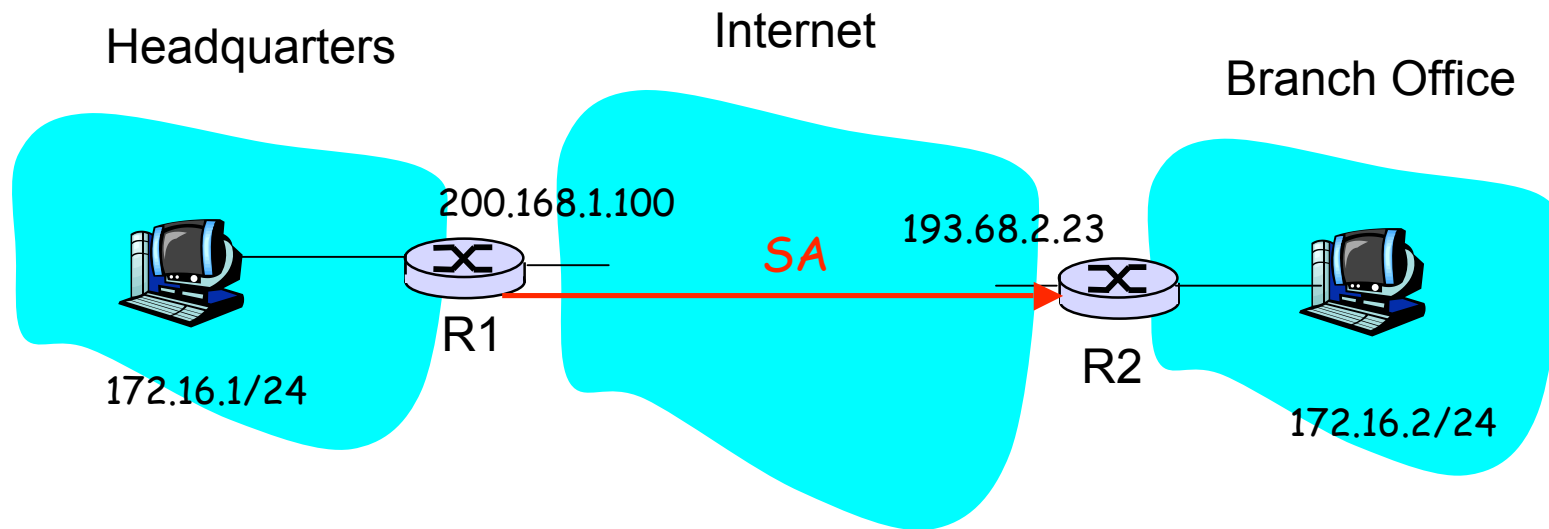

← “enchilada” authenticated →

← encrypted →

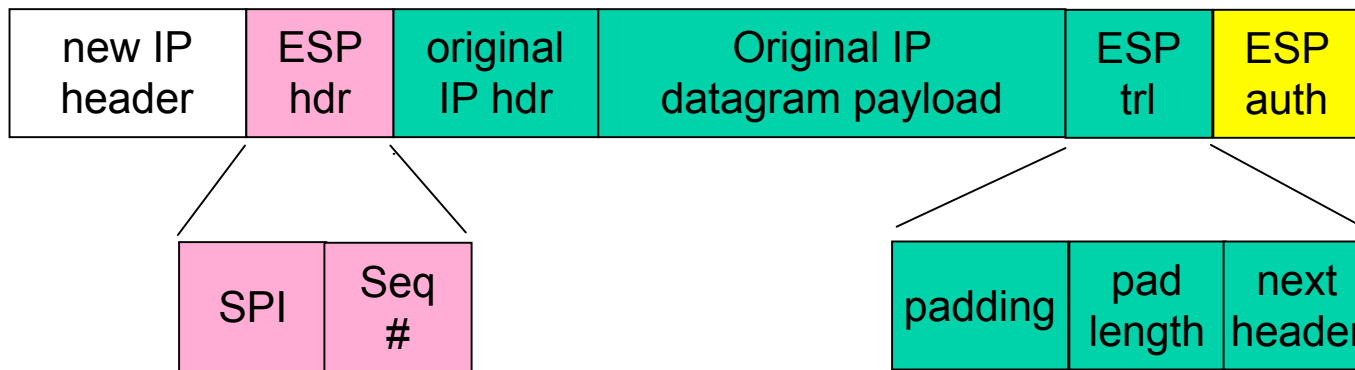

R1 converts original datagram into IPsec datagram

- ❑ Appends to back of original datagram (which includes original header fields!) an "ESP trailer" field.
- ❑ Encrypts result using algorithm & key specified by SA.
- ❑ Appends to front of this encrypted quantity the "ESP header, creating "enchilada".
- ❑ Creates authentication MAC over the *whole enchilada*, using algorithm and key specified in SA;
- ❑ Appends MAC to back of enchilada, forming *payload*;
- ❑ Creates brand new IP header, with all the classic IPv4 header fields, which it appends before payload.

Inside the enchilada:

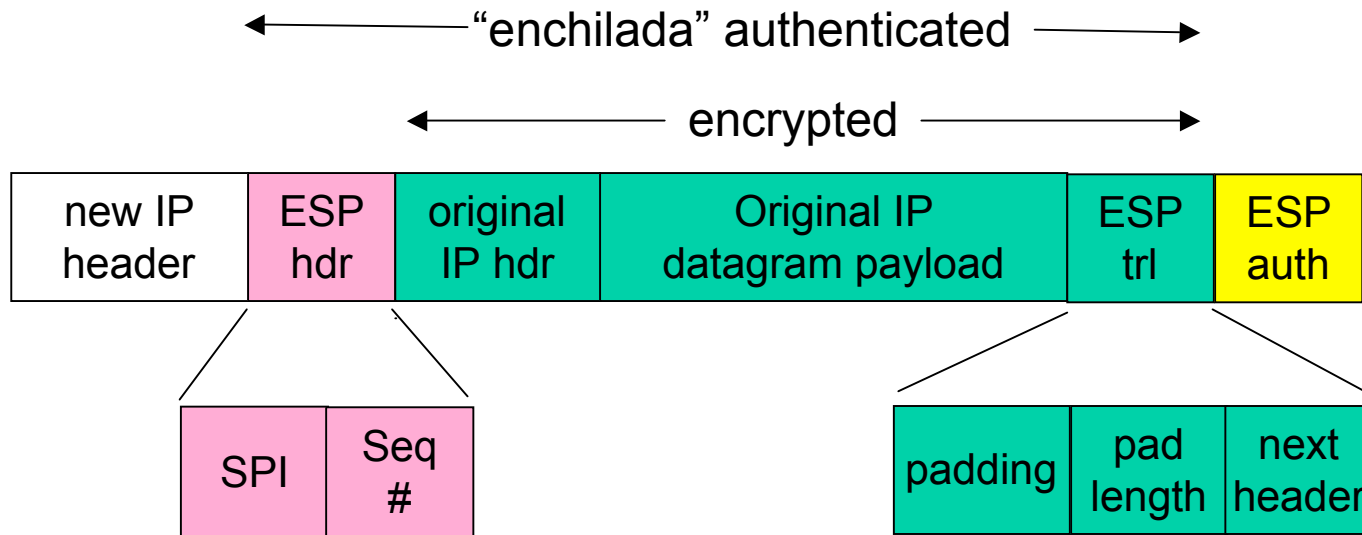

- ❑ ESP trailer: Padding for block ciphers
- ❑ ESP header:
 - SPI, so receiving entity knows what to do
 - Sequence number, to thwart replay attacks
- ❑ MAC in ESP auth field is created with shared secret key

IPsec sequence numbers

- ❑ For new SA, sender initializes seq. # to 0
- ❑ Each time datagram is sent on SA:
 - Sender increments seq # counter
 - Places value in seq # field
- ❑ Goal:
 - Prevent attacker from sniffing and replaying a packet
 - Receipt of duplicate, authenticated IP packets may disrupt service
- ❑ Method:
 - Destination checks for duplicates
 - But doesn't keep track of ALL received packets; instead uses a window

Security Policy Database (SPD)

- ❑ Policy: For a given datagram, sending entity needs to know if it should use IPsec.
- ❑ Needs also to know which SA to use
 - May use: source and destination IP address; protocol number.
- ❑ Info in SPD indicates "what" to do with arriving datagram;
- ❑ Info in the SAD indicates "how" to do it.

Summary: IPsec services

- Suppose Trudy sits somewhere between R1 and R2. She doesn't know the keys.
 - Will Trudy be able to see contents of original datagram? How about source, dest IP address, transport protocol, application port?
 - Flip bits without detection?
 - Masquerade as R1 using R1's IP address?
 - Replay a datagram?

Internet Key Exchange

- ❑ In previous examples, we manually established IPsec SAs in IPsec endpoints:

Example SA

SPI: 12345

Source IP: 200.168.1.100

Dest IP: 193.68.2.23

Protocol: ESP

Encryption algorithm: 3DES-cbc

HMAC algorithm: MD5

Encryption key: 0x7aeaca...

HMAC key:0xc0291f...

- ❑ Such manually keying is impractical for large VPN with, say, hundreds of sales people.
- ❑ Instead use *IPsec IKE (Internet Key Exchange)*

IKE: PSK and PKI

- ❑ Authentication (proof who you are) with either
 - pre-shared secret (PSK) or
 - with PKI (public/private keys and certificates).
- ❑ With PSK, both sides start with secret:
 - then run IKE to authenticate each other and to generate IPsec SAs (one in each direction), including encryption and authentication keys
- ❑ With PKI, both sides start with public/private key pair and certificate.
 - run IKE to authenticate each other and obtain IPsec SAs (one in each direction).
 - Similar with handshake in SSL.

IKE Phases

- ❑ IKE has two phases
 - Phase 1: Establish bi-directional IKE SA
 - Note: IKE SA different from IPsec SA
 - Also called ISAKMP security association
 - Phase 2: ISAKMP is used to securely negotiate the IPsec pair of SAs
- ❑ Phase 1 has two modes: aggressive mode and main mode
 - Aggressive mode uses fewer messages
 - Main mode provides identity protection and is more flexible

Summary of IPsec

- ❑ IKE message exchange for algorithms, secret keys, SPI numbers
- ❑ Either the AH or the ESP protocol (or both)
- ❑ The AH protocol provides integrity and source authentication
- ❑ The ESP protocol (with AH) additionally provides encryption
- ❑ IPsec peers can be two end systems, two routers/firewalls, or a router/firewall and an end system

Chapter 8 roadmap

8.1 What is network security?

8.2 Principles of cryptography

8.3 Message integrity

8.4 Securing e-mail

8.5 Securing TCP connections: SSL

8.6 Network layer security: IPsec

8.7 Securing wireless LANs

8.8 Operational security: firewalls and IDS

WEP Design Goals

- ❑ Symmetric key crypto
 - Confidentiality
 - Station authorization
 - Data integrity
- ❑ Self synchronizing: each packet separately encrypted
 - Given encrypted packet and key, can decrypt; can continue to decrypt packets when preceding packet was lost
 - Unlike Cipher Block Chaining (CBC) in block ciphers
- ❑ Efficient
 - Can be implemented in hardware or software

Review: Symmetric Stream Ciphers

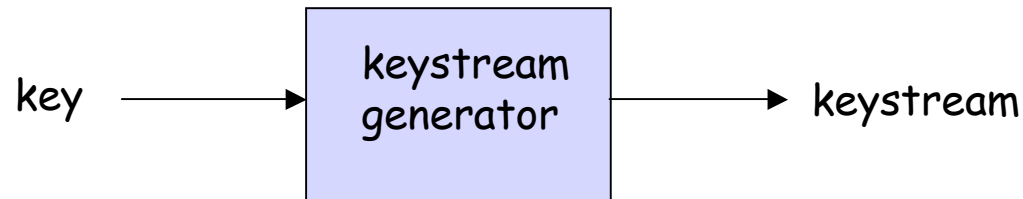

- ❑ Combine each byte of keystream with byte of plaintext to get ciphertext
- ❑ $m(i)$ = i th unit of message
- ❑ $ks(i)$ = i th unit of keystream
- ❑ $c(i)$ = i th unit of ciphertext
- ❑ $c(i) = ks(i) \oplus m(i)$ (\oplus = exclusive or)
- ❑ $m(i) = ks(i) \oplus c(i)$
- ❑ WEP uses RC4

Stream cipher and packet independence

- ❑ Recall design goal: each packet separately encrypted
- ❑ If for frame $n+1$, use keystream from where we left off for frame n , then each frame is not separately encrypted
 - Need to know where we left off for packet n
- ❑ WEP approach: initialize keystream with key + new IV for each packet:



WEP encryption (1)

- ❑ Sender calculates Integrity Check Value (ICV) over data
 - four-byte hash/CRC for data integrity
- ❑ Each side has 104-bit shared key
- ❑ Sender creates 24-bit initialization vector (IV), appends to key: gives 128-bit key
- ❑ Sender also appends keyID (in 8-bit field)
- ❑ 128-bit key inputted into pseudo random number generator to get keystream
- ❑ data in frame + ICV is encrypted with RC4:
 - Bytes of keystream are XORed with bytes of data & ICV
 - IV & keyID are appended to encrypted data to create payload
 - Payload inserted into 802.11 frame

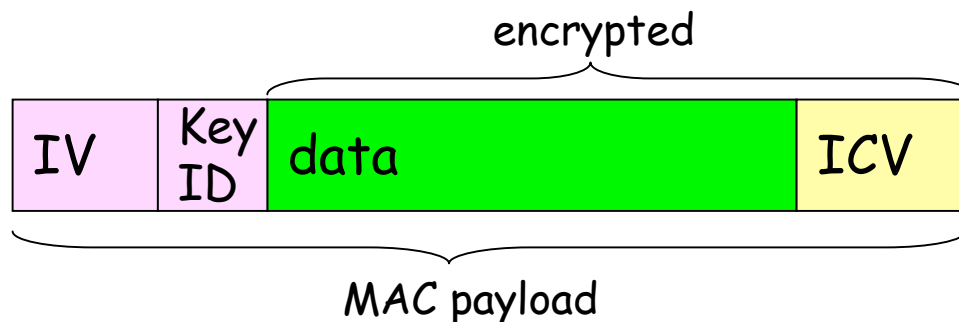

WEP encryption (2)

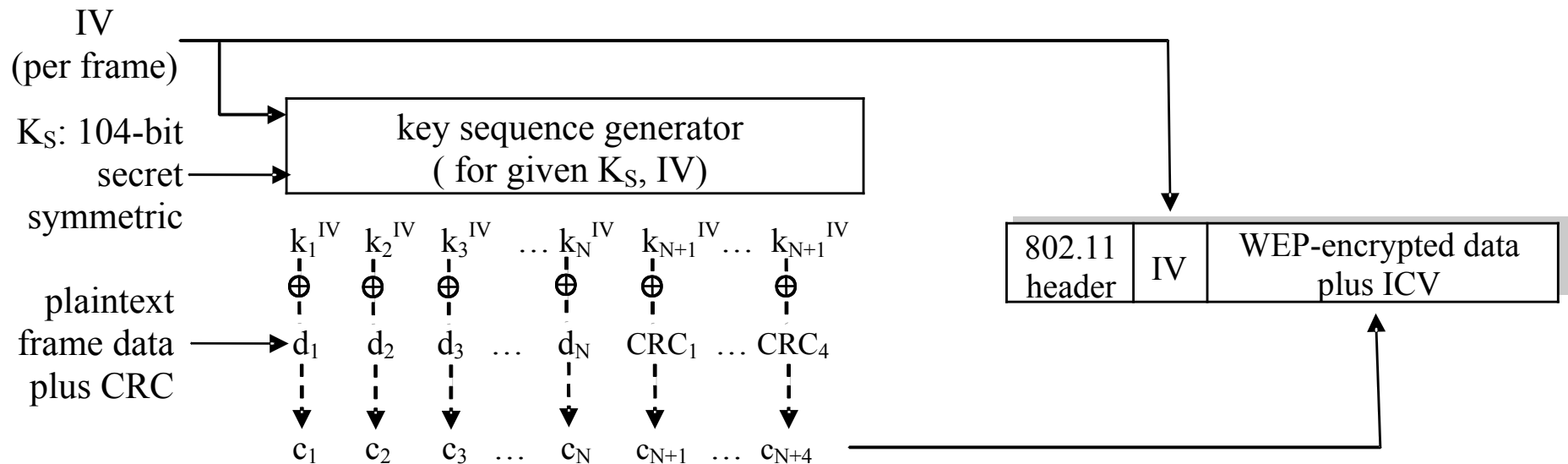

New IV for each frame

WEP decryption overview

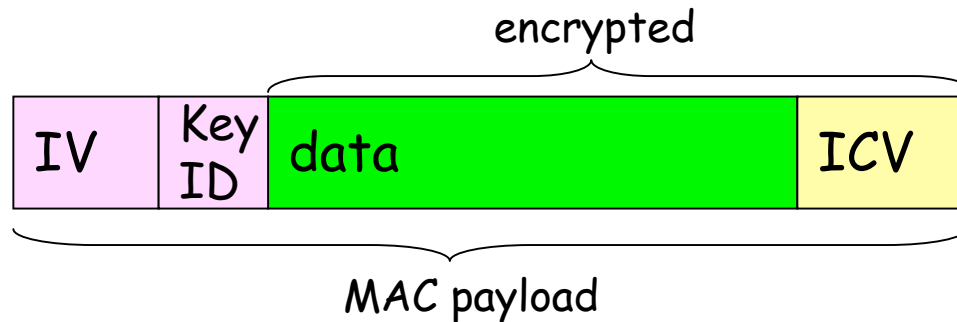

- ❑ Receiver extracts IV
- ❑ Inputs IV and shared secret key into pseudo random generator, gets keystream
- ❑ XORs keystream with encrypted data to decrypt data + ICV
- ❑ Verifies integrity of data with ICV
 - Note that message integrity approach used here is different from the MAC (message authentication code) and signatures (using PKI).

End-point authentication w/ nonce

Nonce: number (R) used only *once -in-a-lifetime*

How: to prove Alice "live", Bob sends Alice **nonce**, R. Alice must return R, encrypted with shared secret key

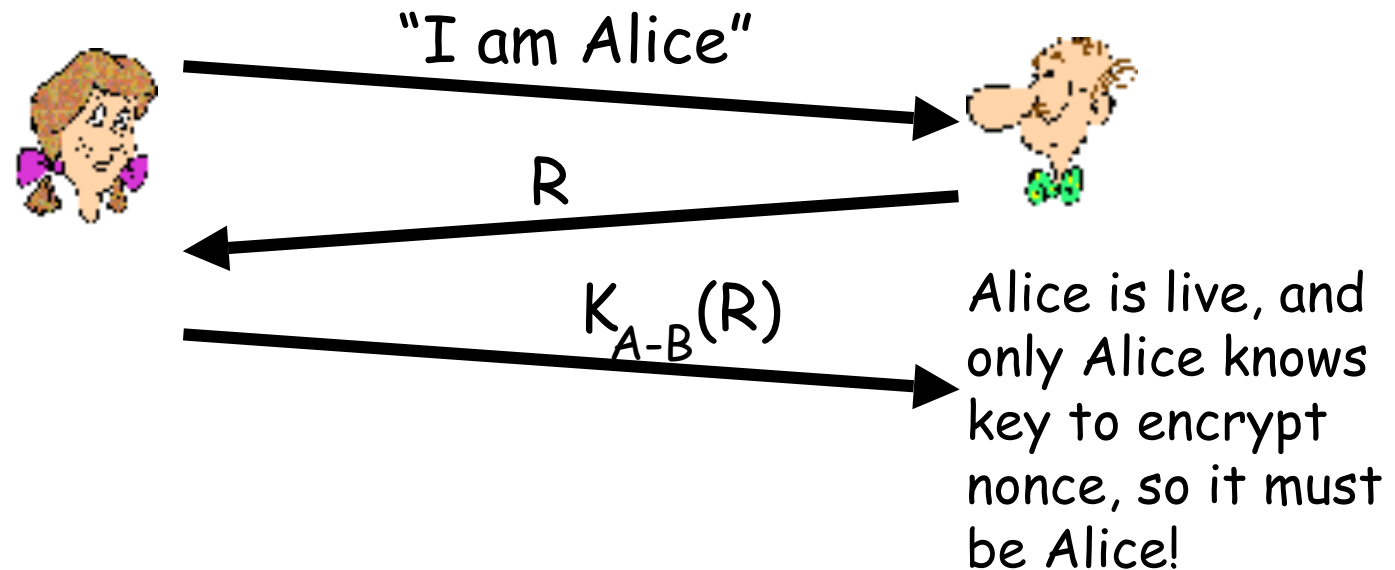

WEP Authentication

Not all APs do it, even if WEP is being used. AP indicates if authentication is necessary in beacon frame. Done before association.

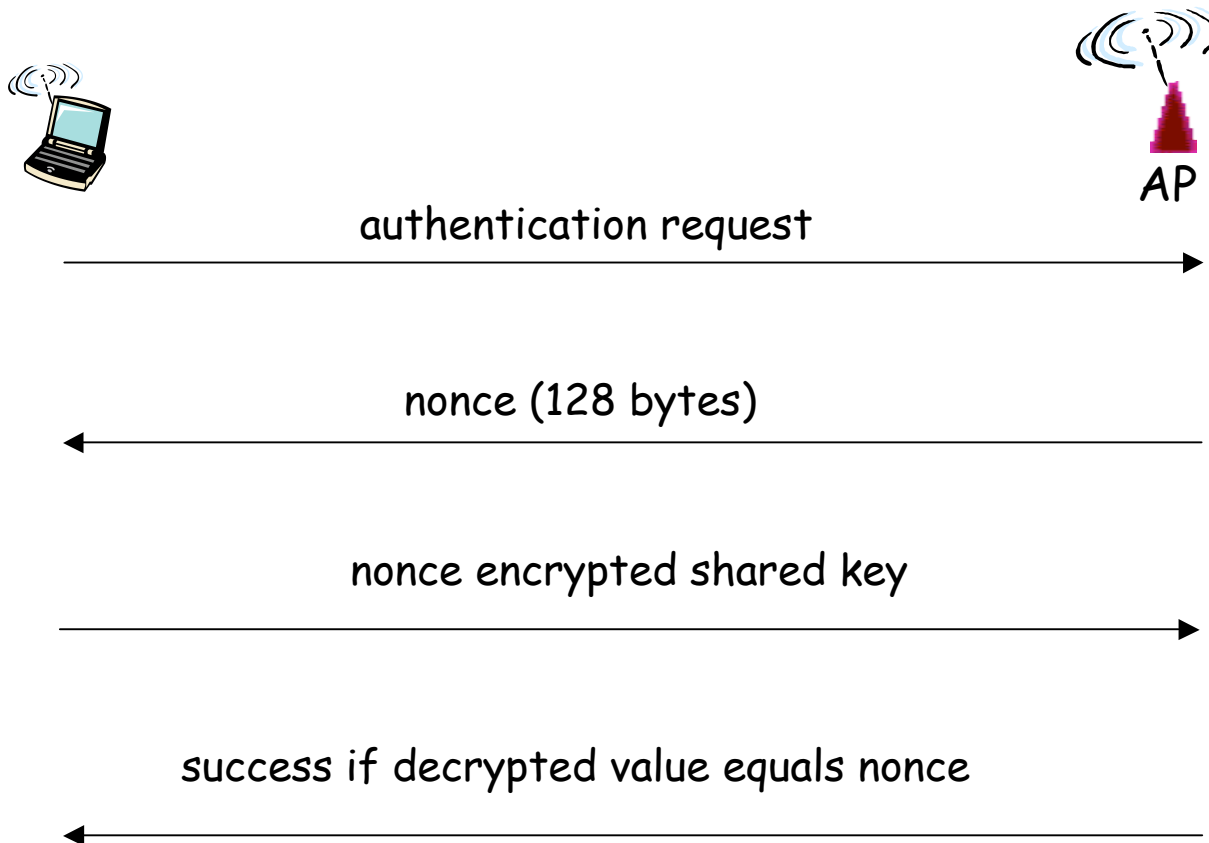

Breaking 802.11 WEP encryption

security hole:

- ❑ 24-bit IV, one IV per frame, -> IV's eventually reused
- ❑ IV transmitted in plaintext -> IV reuse detected
- ❑ **attack:**
 - Trudy causes Alice to encrypt known plaintext $d_1 d_2 d_3 d_4 \dots$
 - Trudy sees: $c_i = d_i \text{ XOR } k_i^{\text{IV}}$
 - Trudy knows $c_i d_i$, so can compute k_i^{IV}
 - Trudy knows encrypting key sequence $k_1^{\text{IV}} k_2^{\text{IV}} k_3^{\text{IV}} \dots$
 - Next time IV is used, Trudy can decrypt!

802.11i: improved security

- ❑ numerous (stronger) forms of encryption possible
- ❑ provides key distribution
- ❑ uses authentication server separate from access point

802.11i: four phases of operation

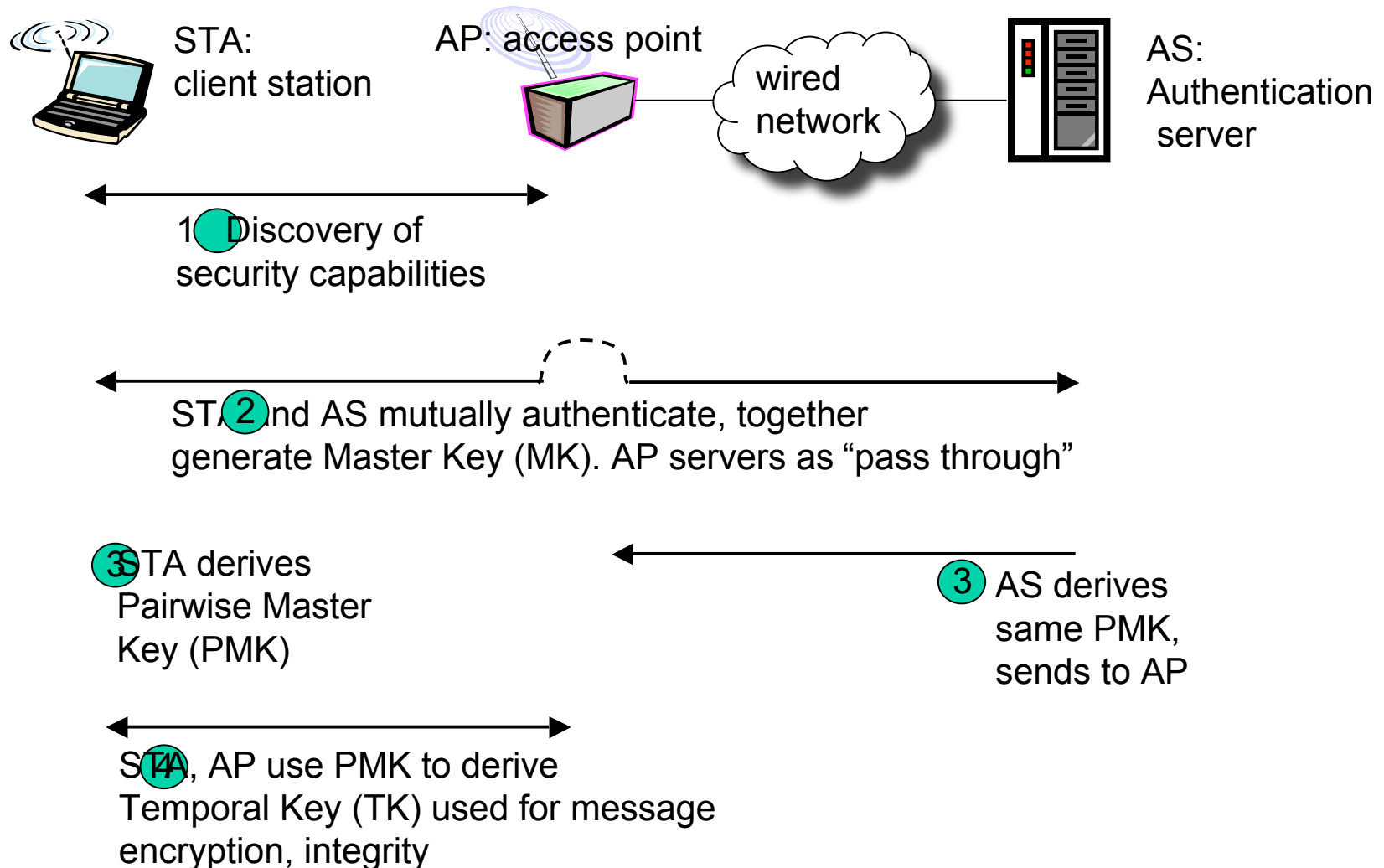

EAP: extensible authentication protocol

- ❑ EAP: end-end client (mobile) to authentication server protocol
- ❑ EAP sent over separate "links"
 - mobile-to-AP (EAP over LAN)
 - AP to authentication server (RADIUS over UDP)

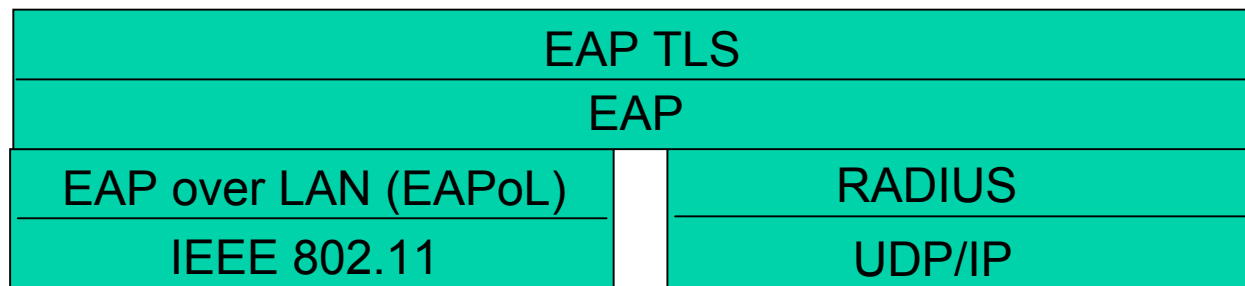
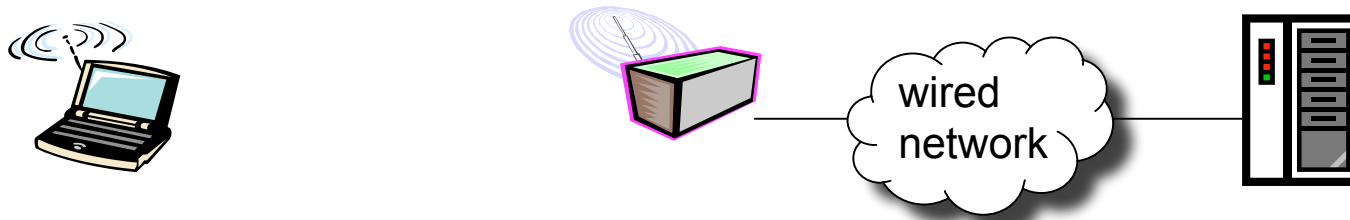

Chapter 8 roadmap

8.1 What is network security?

8.2 Principles of cryptography

8.3 Message integrity

8.4 Securing e-mail

8.5 Securing TCP connections: SSL

8.6 Network layer security: IPsec

8.7 Securing wireless LANs

8.8 Operational security: firewalls and IDS

Firewalls

firewall

isolates organization's internal net from larger Internet, allowing some packets to pass, blocking others.

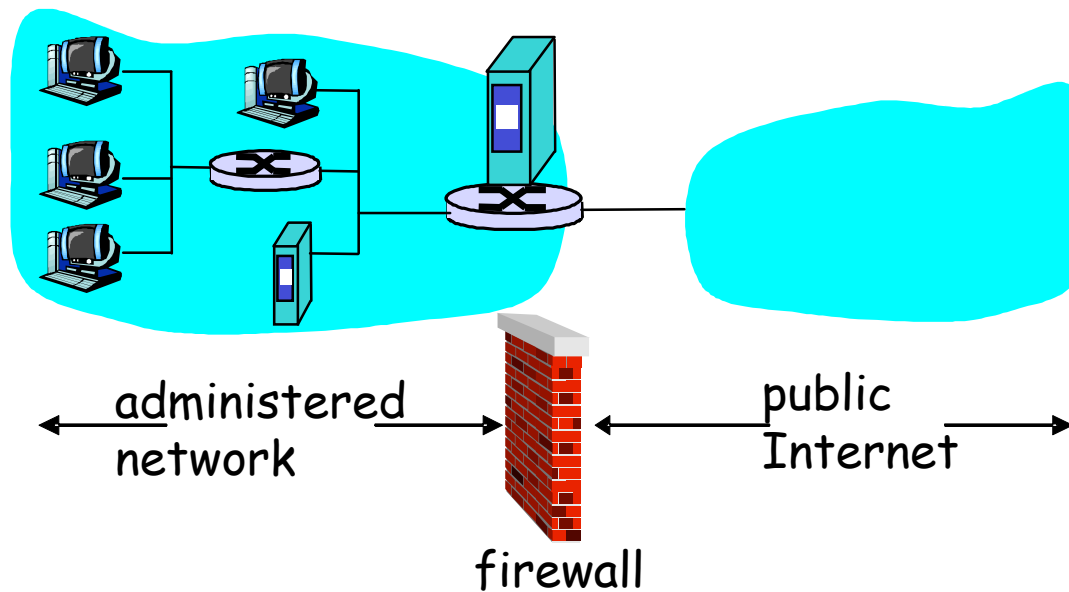

Firewalls: Why

prevent denial of service attacks:

- SYN flooding: attacker establishes many bogus TCP connections, no resources left for "real" connections

prevent illegal modification/access of internal data.

- e.g., attacker replaces CIA's homepage with something else

allow only authorized access to inside network (set of authenticated users/hosts)

three types of firewalls:

- stateless packet filters
- stateful packet filters
- application gateways

Stateless packet filtering

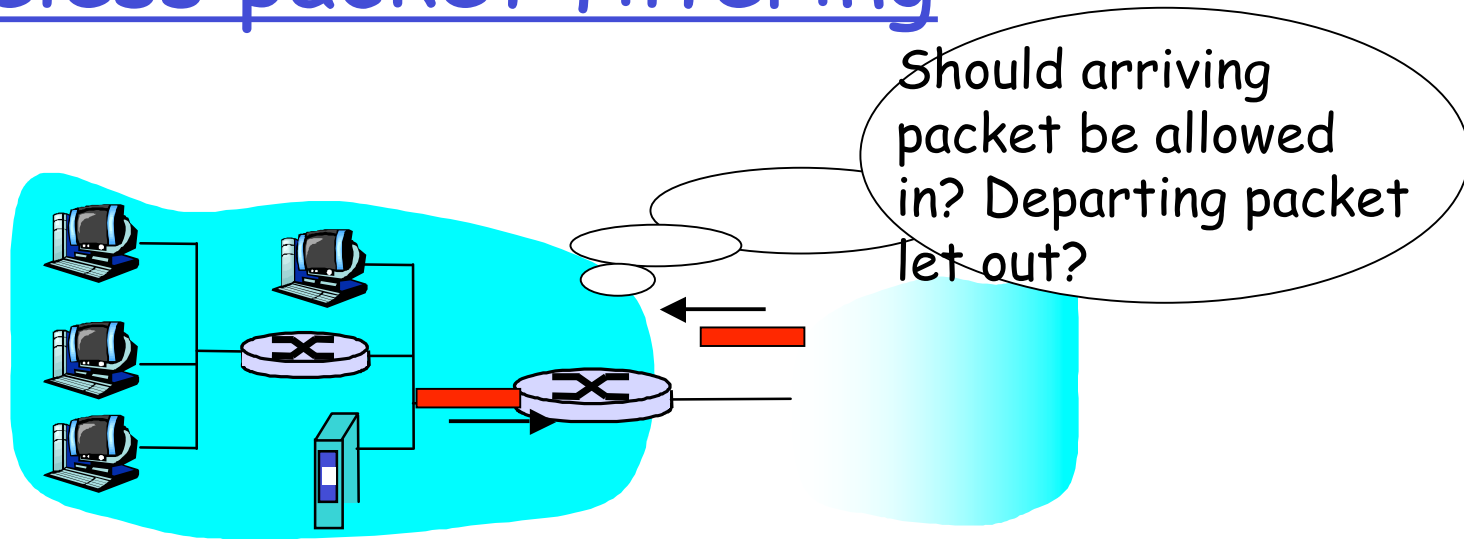

- ❑ internal network connected to Internet via **router firewall**
- ❑ router **filters packet-by-packet**, decision to forward/drop packet based on:
 - source IP address, destination IP address
 - TCP/UDP source and destination port numbers
 - ICMP message type
 - TCP SYN and ACK bits

Stateless packet filtering: example

- ❑ example 1: block incoming and outgoing datagrams with IP protocol field = 17 and with either source or dest port = 23.
 - all incoming, outgoing UDP flows and telnet connections are blocked.
- ❑ example 2: Block inbound TCP segments with ACK=0.
 - prevents external clients from making TCP connections with internal clients, but allows internal clients to connect to outside.

Stateless packet filtering: more examples

<u>Policy</u>	<u>Firewall Setting</u>
No outside Web access.	Drop all outgoing packets to any IP address, port 80
No incoming TCP connections, except those for institution's public Web server only.	Drop all incoming TCP SYN packets to any IP except 130.207.244.203, port 80
Prevent Web-radios from eating up the available bandwidth.	Drop all incoming UDP packets - except DNS and router broadcasts.
Prevent your network from being used for a smurf DoS attack.	Drop all ICMP packets going to a "broadcast" address (eg 130.207.255.255).
Prevent your network from being tracerouted	Drop all outgoing ICMP TTL expired traffic

Access Control Lists

- **ACL**: table of rules, applied top to bottom to incoming packets: (action, condition) pairs

action	source address	dest address	protocol	source port	dest port	flag bit
allow	222.22/16	outside of 222.22/16	TCP	> 1023	80	any
allow	outside of 222.22/16	222.22/16	TCP	80	> 1023	ACK
allow	222.22/16	outside of 222.22/16	UDP	> 1023	53	---
allow	outside of 222.22/16	222.22/16	UDP	53	> 1023	----
deny	all	all	all	all	all	all

Stateful packet filtering

- ❑ stateless packet filter: heavy handed tool
 - admits packets that "make no sense," e.g., dest port = 80, ACK bit set, even though no TCP connection established:

action	source address	dest address	protocol	source port	dest port	flag bit
allow	outside of 222.22/16	222.22/16	TCP	80	> 1023	ACK

- ❑ *stateful packet filter*: track status of every TCP connection
 - track connection setup (SYN), teardown (FIN): can determine whether incoming, outgoing packets "makes sense"
 - timeout inactive connections at firewall: no longer admit packets

Stateful packet filtering

- ACL augmented to indicate need to check connection state table before admitting packet

action	source address	dest address	proto	source port	dest port	flag bit	check conxion
allow	222.22/16	outside of 222.22/16	TCP	> 1023	80	any	
allow	outside of 222.22/16	222.22/16	TCP	80	> 1023	ACK	×
allow	222.22/16	outside of 222.22/16	UDP	> 1023	53	---	
allow	outside of 222.22/16	222.22/16	UDP	53	> 1023	----	×
deny	all	all	all	all	all	all	

Application gateways

- filters packets on application data as well as on IP/TCP/UDP fields.
- example: allow select internal users to telnet outside.

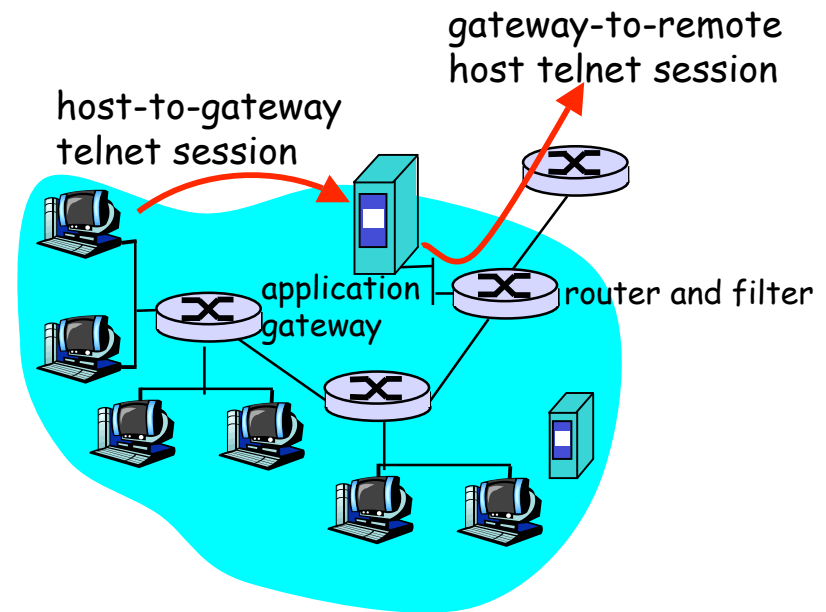

1. require all telnet users to telnet through gateway.
2. for authorized users, gateway sets up telnet connection to dest host. Gateway relays data between 2 connections
3. router filter blocks all telnet connections not originating from gateway.

Limitations of firewalls and gateways

- ❑ IP spoofing: router can't know if data "really" comes from claimed source
- ❑ if multiple app's. need special treatment, each has own app. gateway.
- ❑ client software must know how to contact gateway.
 - e.g., must set IP address of proxy in Web browser
- ❑ filters often use all or nothing policy for UDP.
- ❑ tradeoff: **degree of communication with outside world, level of security**
- ❑ many highly protected sites still suffer from attacks.

Intrusion detection systems

□ packet filtering:

- operates on TCP/IP headers only
- no correlation check among sessions

□ *IDS: intrusion detection system*

- *deep packet inspection*: look at packet contents (e.g., check character strings in packet against database of known virus, attack strings)
- examine correlation among multiple packets
 - port scanning
 - network mapping
 - DoS attack

Intrusion detection systems

- multiple IDSs: different types of checking at different locations

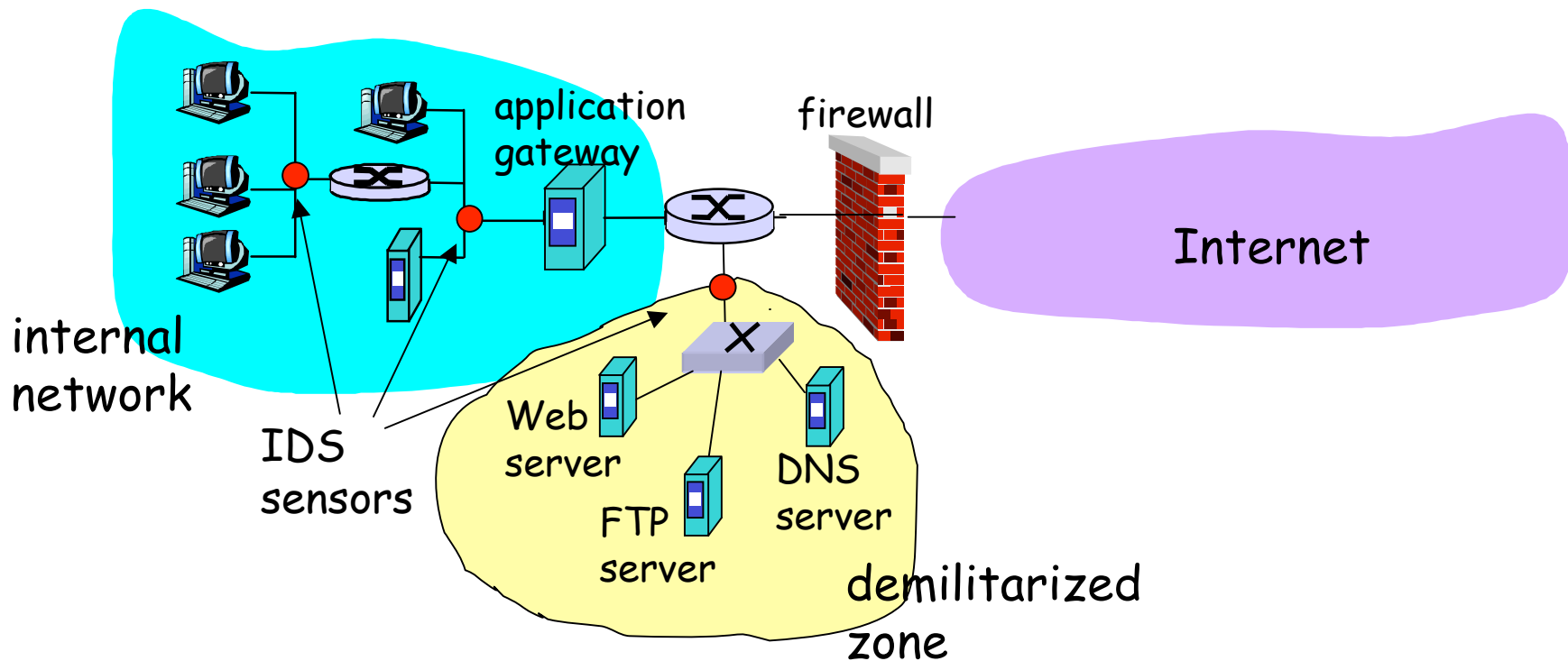

Network Security (summary)

Basic techniques.....

- cryptography (symmetric and public)
- message integrity
- end-point authentication

.... used in many different security scenarios

- secure email
- secure transport (SSL)
- IP sec
- 802.11

Operational Security: firewalls and IDS