

Chapter 9

Landing Gear Design

Mohammad Sadraey
Daniel Webster College

Table of Contents

Chapter 9.....	3
Landing Gear Design	3
9.1. Introduction.....	3
9.2. Design Requirements and Design Flowchart.....	4
9.3. Landing Gear Configuration	7
9.3.1. Single Main.....	8
9.3.2. Bicycle	9
9.3.3. Tail-gear.....	9
9.3.4. Tricycle	11
9.3.5. Quadricycle.....	11
9.3.6. Multi-bogey.....	12
9.3.7. Releasable Rail.....	12
9.3.8. Skid	12
9.3.9. Seaplane Landing Device.....	12
9.3.10. Human Leg.....	14
9.3.11. Landing Gear Configuration Selection Process	15
9.3.12. Landing Gear Attachment.....	15
9.4. Fixed, Retractable, or Separable Landing Gear	16
9.5. Landing Gear Geometry	19
9.5.1. Landing Gear Height.....	19
9.5.2. Wheel Base	23
9.5.3. Wheel Track.....	26
9.6. Landing Gear and Aircraft Center of Gravity	34
9.6.1. Tipback and Tipforward Angles Requirements	34
9.6.2. Take-off Rotation Requirement	35
9.7. Landing Gear Mechanical Subsystems/Parameters	41
9.7.1. Tire Sizing.....	42
9.7.2. Shock Absorber.....	42

9.7.3. Strut Sizing.....	43
9.7.4. Steering Subsystem.....	43
9.7.5. Landing Gear Retraction system.....	44
9.8. Landing Gear Design Steps.....	45
9.9. Landing Gear Design Example	46
Problems	56
References.....	61

Chapter 9

Landing Gear Design

9.1. Introduction

Another aircraft major component that is needed to be designed is landing gear (undercarriage). The landing gear is the structure that supports an aircraft on the ground and allows it to taxi, take-off, and land. In fact, landing gear design tends to have several interferences with the aircraft structural design. In this book, the structural design aspects of landing gear are not addressed; but, those design parameters which strongly impact the aircraft configuration design and aircraft aerodynamics will be discussed. In addition, some aspects of landing gear such as shock absorber, retraction mechanism and brakes are assumed as non-aeronautical issues and may be determined by a mechanical engineer. Thus, those pure mechanical parameters will not be considered in this chapter either. In general, the followings are the landing gear parameters which are to be determined in this chapter:

1. Type (e.g. nose gear (tricycle), tail gear, bicycle)
2. Fixed (faired, or un-faired), or retractable, partially retractable
3. Height
4. Wheel base
5. Wheel track
6. The distance between main gear and aircraft cg
7. Strut diameter
8. Tire sizing (diameter, width)
9. Landing gear compartment if retracted
10. Load on each strut

Landing gear usually includes wheels, but some aircraft are equipped with skis for snow or float for water. In the case of a vertical take-off and landing aircraft such as a helicopter, wheels may be replaced with skids. Figure 9.1 illustrates landing gear primary parameters. The descriptions of primary parameters are as follows. Landing gear height is the distance between the lowest point of the landing gear (i.e. bottom of the tire) and the attachment point to the aircraft. Since, landing gear may be attached to the fuselage or to the wing; the term height has different meaning. Furthermore, the landing gear height is a function of shock absorber and the landing gear deflection. The height is usually measured when the aircraft is on the ground; it has maximum take-off weight; and landing gear has the maximum deflection (i.e. lowest height).

Thus, the landing gear when it has the maximum extension is still height, but is less important and application. The distance between the lowest point of the landing gear (i.e. ground) to the aircraft cg

is also of significant importance and will be employed during calculations. Wheel base is the distance between main gear and other gear (from side view). The landing gear is divided into two sections: 1. Main gear or main wheel¹, 2. Secondary gear or secondary wheel. Main gear is the gear which is the closest to the aircraft center of gravity (cg). During the landing operation, the main wheel touches first with the point of contact to the ground. Furthermore, during the take-off operation, the main wheel leaves the ground last. On the other hand, main gear is carrying great portion of the aircraft load on the ground.

Wheel track is the distance between two main gears (left and right) from front view. If a gear is expected to carry high load, it may have more than one wheel.

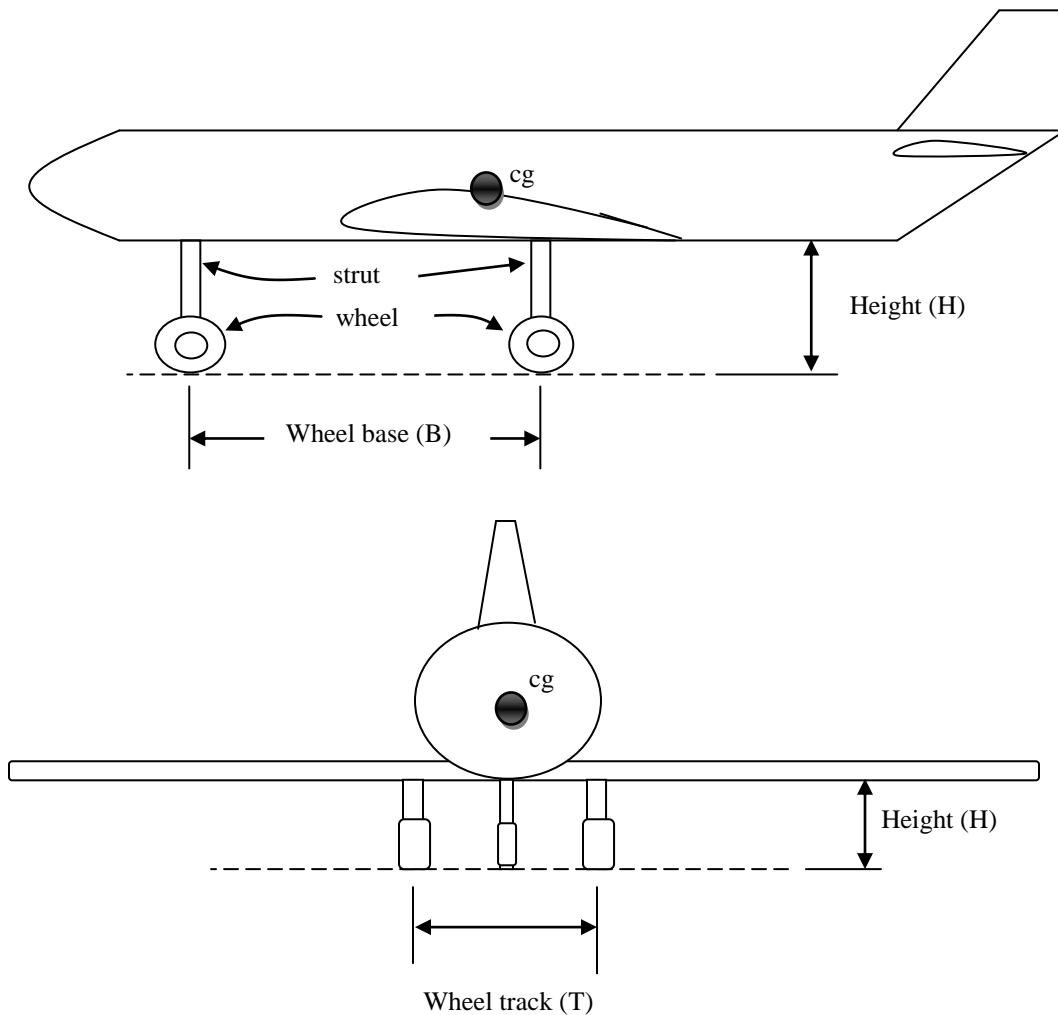

Figure 9.1. *Landing gear primary parameters*

9.2. Design Requirements and Design Flowchart

In terms of design procedure, the landing gear is the last aircraft major component which is designed. In another word, all major components (such as wing, tail, fuselage, and propulsion system) must be designed prior to the design of landing gear. Furthermore, the aircraft most aft center of gravity (cg) and the most forward cg must be known for landing gear design. In some instances, the landing gear design

¹ The term “wheel” is often used to mean the entire wheel/brake/tire assembly.

may drive the aircraft designer to change the aircraft configuration to satisfy landing gear design requirements.

Primary functions of a landing gear are as follows:

1. Keep the aircraft stable on the ground and during loading, unloading, and taxi
2. Allow the aircraft to freely move and maneuver during taxing
3. Provide a safe distance between other aircraft components such as wing and fuselage while the aircraft is on the ground position to prevent any damage by the ground contact
4. Absorb the landing shocks during landing operation
5. Facilitate take-off by allowing aircraft acceleration and rotation with the lowest friction

No	Requirements and constraints	Requirement	Parameter affected
1	Ground clearance	- Prop to ground during Take-off > X inch - Wing, engine, fuselage clearance must be reasonable	Height
2	Controllability (Steering)	15% > Load on nose well > 5% W_{TO}	$D_{n_{cg}}$
3	Take-off rotation	-aft fuselage and tail during TO rotation: no contact and hit - cg must not be too close to nose gear such that lift off is difficult	Height; D_{m_t}
4	Tip back prevention	Prevent tip back on its tail: the angle off the vertical from the main wheel position to the cg should be greater than tip back angle or 15 deg, whichever is larger ($25 > Tip\ back\ angle > 15$)	
5	Overturn prevention	Lateral angle > 60 deg to prevent overturn when taxied around sharp corner	Wheel track
6	Touch-down	Shock absorber must absorb and mitigate dynamic loads	shock absorber; tire
7	Landing	Landing speed must be brought to zero before end of runway	brake
8	Static and dynamic loading	Tires and struts must be able to function in static (W_{TO} or W_L) and dynamic load (hitting the runway)	Strut
9	Structural integrity	The wing deflection (front view) on the ground due to the aircraft weight must be minimal	Wheel track
10	Ground lateral stability	The aircraft should not roll over due to a cross wind	Wheel track, height

Table 9.1. Relationship between landing gear design requirements and landing gear parameters

In order to allow for a landing gear to function effectively, the following design requirements are established:

1. Ground clearance requirement
2. Steering requirement
3. Take-off rotation requirement
4. Tip back prevention requirement
5. Overturn prevention requirement
6. Touch-down requirement
7. Landing requirement
8. Static and dynamic load requirement

9. Aircraft structural integrity

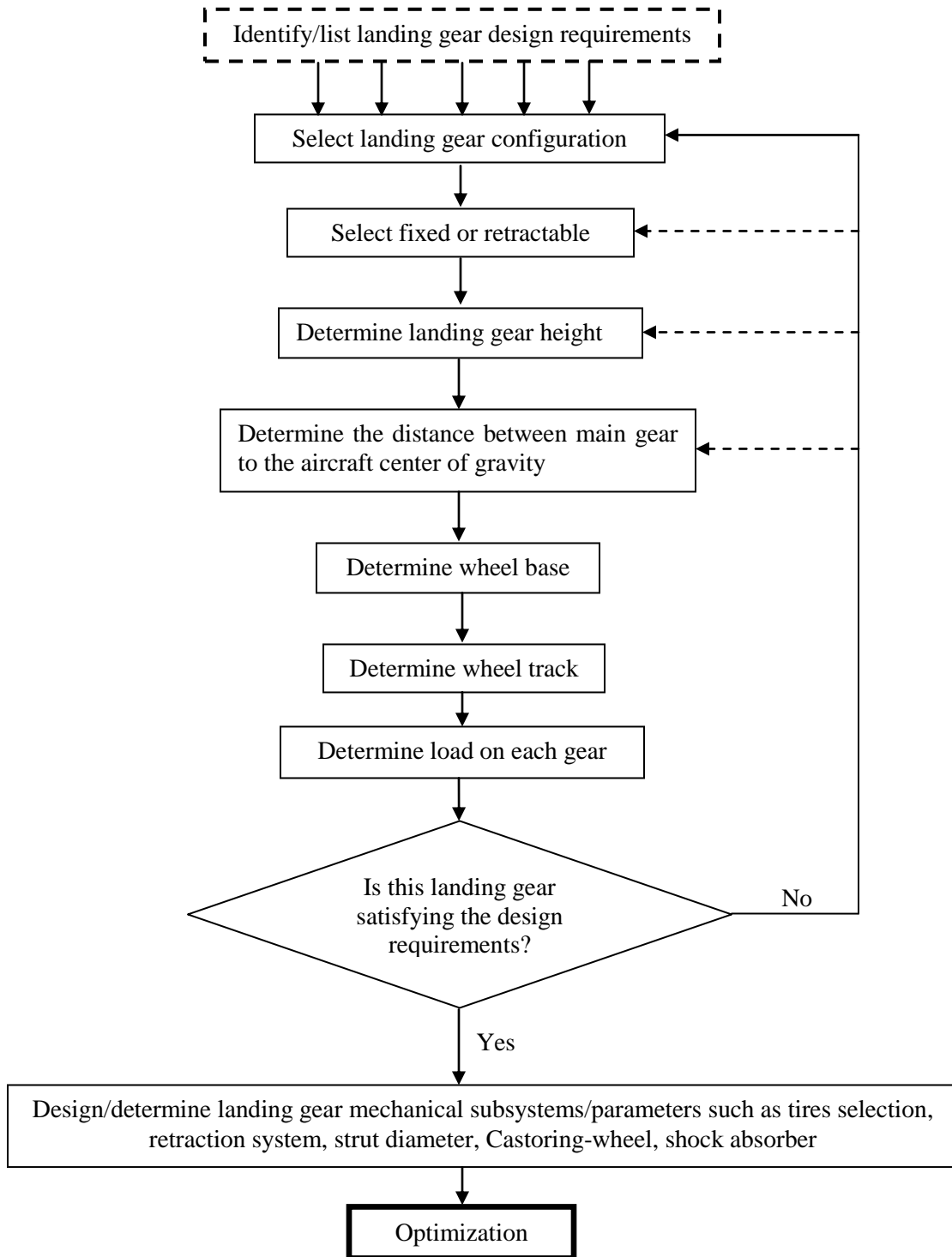

Figure 9.2. Landing gear design flowchart

- 10. Ground lateral stability
- 11. Low cost
- 12. Low weight

- 13. Maintainability
- 14. Manufacturability

Table 9.1 shows more details of the design requirements plus relationship between the requirements and landing gear parameters. Technical aspects of these requirements are described in Sections 9.5 and 9.6. In the next sections, techniques to determine landing gear parameters to satisfy all requirements will be presented.

While the aircraft landing gear is a crucial component for take-off and landing, it is a dead weight during airborne flight operations. For this reason, it is recommended to retract the landing gear inside aircraft to reduce aircraft drag and improve aircraft performance. Figure 9.2 illustrates landing gear design flowchart including design feedbacks. As the flowchart presents, the landing gear design is an iterative process and the number of iterations depends on the nature of design requirements as well as designer's skills. Furthermore, the design of mechanical subsystems and parameters is grouped in one box and should be performed by the mechanical design group. We initiate the landing gear design by defining landing gear design requirements and the process is ended by the optimization. The details of the design of such items are out of scope of this textbook and the reader is referred to other references such as Ref 1.

9.3. Landing Gear Configuration

The first job of an aircraft designer in the landing gear design process is to select the landing gear configuration. Landing gear functions may be performed through the application of various landing gear types and configurations. Landing gear design requirements are parts of the aircraft general design requirements including cost, aircraft performance, aircraft stability, aircraft control, maintainability, producibility and operational considerations. In general, there are ten configurations for a landing gear as follows:

1. Single main
2. Bicycle
3. Tail-gear
4. Tricycle or nose-gear
5. Quadricycle
6. Multi-bogey
7. Releasable rail
8. Skid
9. Seaplane landing device
10. Human leg

Features and the technical descriptions of each landing gear configuration will be presented in this section. The common alternatives for landing gear configurations are illustrated in figure 9.3. The landing gear configuration selection process includes setting up a table of features that can be compared in a numerical fashion. The details of the process were covered in Chapter 2. It needs to be clarified that for simplicity the term “gear” or “wheel” is sometimes employed for a single strut and whatever that is connected to it which comprises such items as tire, wheel, shock absorber, actuators, and brake assembly. Hence, when the term “nose-gear” is used, it refers to a landing gear configuration; while when the term “nose gear” is employed, it refers to a gear that is attached under the fuselage nose. In general, most general aviation, transport and fighter aircraft employ tricycle landing gear, while some heavy weight transport (cargo) aircraft use quadricycle or multi-bogy landing gear. Nowadays, the tail-gear is seldom used by some GA aircraft, but it was employed in the first 50 years of aviation history by majority of aircraft.

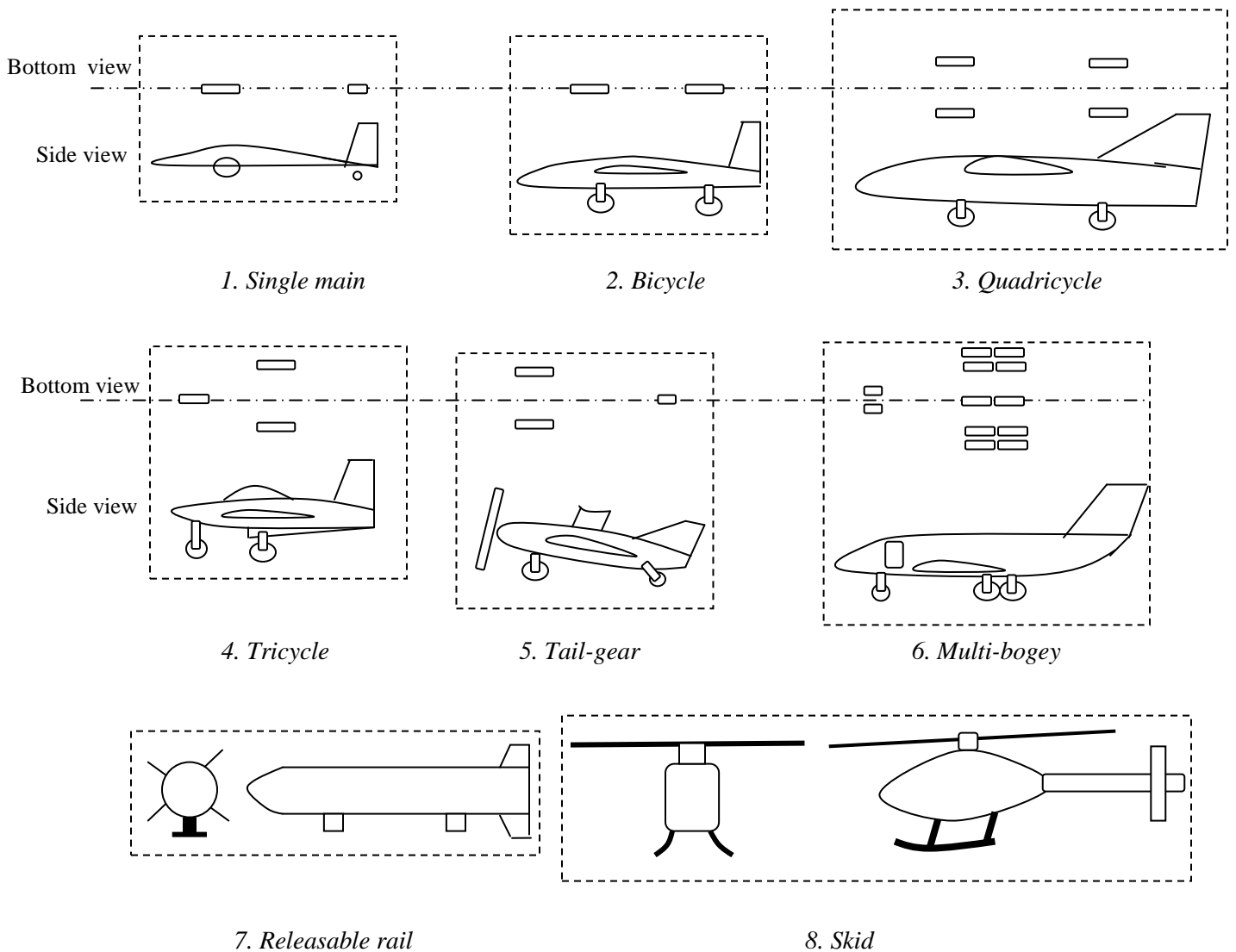

Figure 9.3. Landing gear types

9.3.1. Single Main

The simplest configuration of landing gear is the single main (see Fig. 9.3-1). It includes one large main gear that carries a large portion of the aircraft weight and load; plus a very small gear under the nose. In terms of size, the main gear is much larger (both strut and wheel) than the secondary one. Both of these gears are in the aircraft symmetrical plane. The main gear is close to the aircraft cg, while the other gear is far from it. In majority of cases, the main gear is located in front of the aircraft cg and the other one is behind cg (under the tail section). In case, where the main gear is aft of aircraft cg, the secondary gear is usually converted to a skid under the fuselage nose. Majority of sailplanes are employing single main landing gear because of its simplicity.

The single main landing gear is not usually retracted, so it is very short in height. An aircraft with a single main landing gear is not stable on the ground, so the aircraft will tip over one side (usually on wing tips) while staying on the ground. In such landing gear configuration, an operator must hold the wing level when an aircraft is stationary and prior to take-off. To prevent a sideways tipping, some aircraft

are equipped with two auxiliary small gears under two wing sections. In an aircraft without auxiliary wheels, the wing tips must be repaired in a regular basis, since the wing tips are damaged during each tipping. Two advantages of this arrangement are the simplicity and the low weight of the landing gear. On the other hand, beside the ground instability, a disadvantage of this configuration is the longer take-off run, since the take-off rotation is limited.

9.3.2. Bicycle

Bicycle landing gear, as the name implies, has two main gears (Fig 9.3-2), one aft and one forward of aircraft cg; and both wheels have a similar size. To prevent the aircraft from tipping sideways, two auxiliary small wheels are employed on the wings. The distance between two gears to the aircraft cg is almost the same, thus, both gears are carrying a similar load. The bicycle landing gear has some similar features with single main and in fact is an extension to the single main. This arrangement is not popular among aircraft designers due to its ground instability. The main advantages of this configuration are the design simplicity and the low weight. This landing gear configuration is a cheap candidate for an aircraft with narrow fuselage and high wing configuration. Figure 9.4-2 illustrates the old bomber aircraft Boeing B-47 Stratojet with bicycle landing gear.

9.3.3. Tail-gear

Tail-gear landing gear has two main wheels forward of the aircraft cg and a small wheel under the tail. Figure 9.3-5 illustrates the side and top views of the gear in a typical aircraft. The wheels in front of the aircraft cg is very close to it (compared with aft wheel) and carries much of the aircraft weight and load; thus is referred to as the main wheel. Two main gears are in the same distance from the cg in the x-axis and the same distance in y-axis (in fact left and right sides); thus both are carrying the same load. The aft wheel is far from cg (compared with main gear); hence it carries much smaller load and then is called an auxiliary gear. The share of the main gear from the total load is about 80 to 90 percent of the total load, so the tail gear is carrying about 10 to 20 percent.

This configuration of landing gear is referred to as a conventional landing gear, since it was the primary landing gear during the first 50 years of aviation history. But currently, only about 10 percent of the aircraft produced are employing tail-gear. In order to reduce drag, in some aircraft, a skid (vertical flat plate) is used instead of the tail wheel. Such landing gear is referred to as the tail-dragger. Most agricultural some GA aircraft are equipped with tail gear. The aircraft is not level on the ground, due to the fact that the main gear is much larger and taller than the tail gear. Thus the passengers must climb the floor on such aircraft as Boeing 80 passenger aircraft during 1940s in order to get onboard. Since the aircraft has high angle of attack during ground roll, the tail will be lifted up during take-off operation. This attitude makes the take-off run longer compared with a tricycle landing gear. Another consequence of high angle of attack during take-off is the low pilot view on the runway.

Since the aircraft has three wheels (supporting points), the aircraft is stable on the ground. However, it is inherently directionally unstable during ground maneuver (turn). The reason is that when an aircraft with a tail gear starts to turn on the ground around main gear, the cg behind main gear generates a centrifugal force. If the aircraft ground speed is high enough, the moment of the centrifugal force will be larger than the moment of the friction force on tail gear; so it causes the aircraft to yaw around the main gear. Thus, the aircraft will roll and tip on outer wing-tip-, or will skid off the side of the runway. This aircraft behavior can be easily controlled by lowering the speed during taxi. However, it is potentially possible to go out of control during landing and touch-down, due to cross wind. To prevent this, the pilot needs to dance on the rudder pedals until the aircraft slows down. The World War II aircraft Spitfire and Tiger Moth as well as GA aircraft such as Piper Super Cub, and Cessna 185 had tail gear. Figure 9.4-3 shows the agricultural aircraft Air Tractor AT-802 Turbo Air Tractor with tail-gear configuration.



1. Bomber aircraft Boeing B-47 Stratojet with bicycle landing gear



2. Agricultural aircraft Air Tractor AT-802 Turbo Air Tractor with tail-gear configuration



3. Fighter aircraft F/A-18C Hornet with tricycle landing gear



4. Bomber aircraft B-52 Stratofortress with quadricycle landing gear



5. Boeing 747 with multi-bogey landing gear

Figure 9.4. Several example aircraft with various landing gear configurations

9.3.4. Tricycle

Tricycle is the most widely used landing gear configuration. Figure 9.3-4 shows the side and top views of the gear in a typical aircraft. The wheels aft of the aircraft cg is very close to it (compared with forward gear) and carries much of the aircraft weight and load; thus is referred to as the main wheel. Two main gears are in the same distance from the cg in the x-axis and the same distances in y-axis (left and right sides); thus both are carrying the same load. The forward gear is far from cg (compared with main gear); hence it carries much smaller load. The share of the main gear from the total load is about 80 to 90 percent of the total load, so the nose gear is carrying about 10 to 20 percent. This arrangement is sometimes called nose-gear.

Most GA, transport, and fighter aircraft are equipped with tricycle configuration. Both main and nose gears have the same height, so the aircraft is level on the ground, although the main gears often tends to have larger wheels. This allows the floor to be flat for passenger and cargo loading. Unlike tail-gear, a nose gear configuration aircraft is directionally stable on the ground as well as during taxiing. The reason is that if the aircraft yaws slightly while taxiing, the rolling and skidding resistance of the main gear, acting behind the cg, tends to straighten the aircraft out. This feature enables the aircraft to have a fairly large crab angle during cross wind landing. The pilot view during take-off and landing is much better compared with tail-gear. Aircraft such as Boeing 737, Airbus 320, F-16 Fighting Falcon, Pilatus PC-9, Piper Cherokee, Cessna 208, Embraer EMB 312 Tucano, Mig-29 all have nose-gear configuration. Figure 9.4-4 shows a fighter aircraft F-18 with tricycle configuration.

Most large transport aircraft (e.g. Fokker 100), fighters (e.g. F-18 Hornet) and some military aircraft (e.g. B-2 Spirit) are employing two wheels on the nose gear to increase the safety during take-off and landing in case of flat tire. This is also the case for an aircraft with large load on nose gear. For such a case, instead of one large wheel, two small wheels are utilized to decrease the gear frontal area and also aircraft drag. Carrier-based aircraft such as F-14 Tomcat and F-18 Hornet need to employ two wheels for nose gear in order to be capable to using the catapult launch mechanism.

As the number of wheels is increased, the manufacturing, maintaining, and operating costs will be increased too; while the safety is improved. Furthermore, as the number of wheels is increased, the wheel frontal area is reduced, so the aircraft performance; especially during take-off; will be improved. Another reason for having multiple wheels is to tailor the wheel's overall volume to match to the retraction bay geometry inside the wing or fuselage. Typically, when the aircraft weight is between 70,000 lb and 200,000 lb, two wheels per main strut are employed. The cargo aircraft Lockheed C-5 Galaxy with a very heavy weight (maximum take-off weight of 840,000 lb) employs four nose wheels to spread out the gear load among tires.

9.3.5. Quadricycle

As the name implies a quadricycle landing gear (see Fig. 9.3-3) utilizes four gears; similar to a car conventional wheel system. Two wheels at each side where two wheels are in front of aircraft cg and other two aft of cg. The load on each gear depends on its distance to cg. If aft and forward wheels have the same distance to cg, they will have to carry the same load. In this case, it is very hard to rotate the aircraft during take-off and landing; so the aircraft will perform a flat take-off and landing. This characteristics causes the aircraft to have a longer take-off run, compared with tricycle configuration.

This feature enables the aircraft to have a very low floor which permits an easier loading and unloading. The quadricycle landing gear configuration is usually used in a very heavy cargo or bomber aircraft. Bomber aircraft B-2 (Fig. 9.4-5) is utilizing a quadricycle landing gear. An aircraft with quadricycle landing gear is very stable on the ground and during taxiing.

9.3.6. Multi-bogey

As the aircraft gets heavier, number of gears needs to be increased. A landing gear configuration with multiple gears of more than four wheels also improves take-off and landing safety. When multiple wheels are employed in tandem, they are attached to a structural component (See Fig. 9.3-6) referred to as “bogey” that is connected to the end of the strut. An aircraft with multi-bogey landing gear is very stable on the ground and also during taxiing. Among various landing gear arrangement, a multi-bogey is the most expensive, and most complex for manufacturing. When the aircraft weight is beyond 200,000 lb, multiple bogeys each with four to six wheels are used. Large transport aircraft such as Boeing B-747 (Fig. 9.4-6) and Airbus A-380 utilize multi-bogey landing gear.

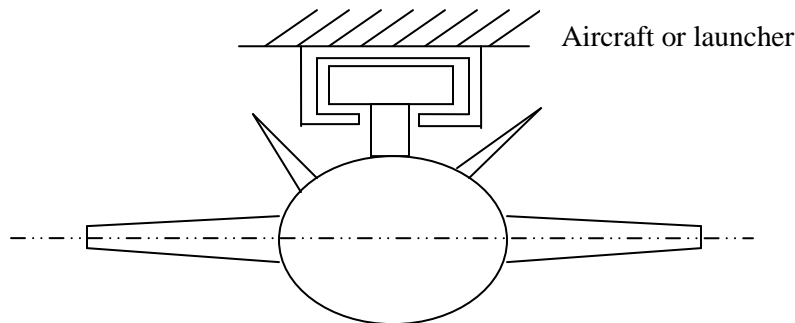

Figure 9.5. *Missile attachment*

9.3.7. Releasable Rail

For those aircraft which are designed to take-off while airborne and are not expected to land on the ground or sea, there is a special type of gear. Rockets and missiles (see Fig. 9.3-7) are in the same category in terms of landing gear configuration. These air vehicles are either launched, or released to get airborne. Take-off or launch gear usually consists of two to fixed three pieces. One piece is a flat plate of T-shape part (Fig 9.5) that is attached to the mother vehicle (e.g. fighter) or launcher. The main function of this attachment is to hold the vehicle while launched.

9.3.8. Skid

Some vertical take-off and landing aircraft and helicopters do not need to taxi on the ground, so they are equipped with a beam-type structure referred to as skids (see Fig 9.3-8) instead of regular landing gear. The configuration of skids mainly comprises of three to four fixed cantilever beams which are deflected outward when a load (i.e. aircraft weight) is applied. The deflection of skids plays the role of a shock absorber during landing operations. However, due to the nature of the beams, they are not as efficient as oleo shock absorbers. The design of skids compared with regular landing gear which are equipped with wheels is much simpler. Basic equations for beam deflection and bending stress might be employed in the design and analysis of skids. In addition, fatigue loading and fatigue life must be taken into account to predict the skid endurance.

9.3.9. Seaplane Landing Device

Take-off and landing on the sea requires special landing gear configuration. The technical features of the water runway are totally different than a hard surface tarmac. Thus, a sea-plane is not able to employ the advantages of wheels on the water. The sea-plane landing gear and the shape of the hull are governed by the following design requirements:

1. Slipping
2. Water-impact load reduction
3. Floating

4. Lateral static stability

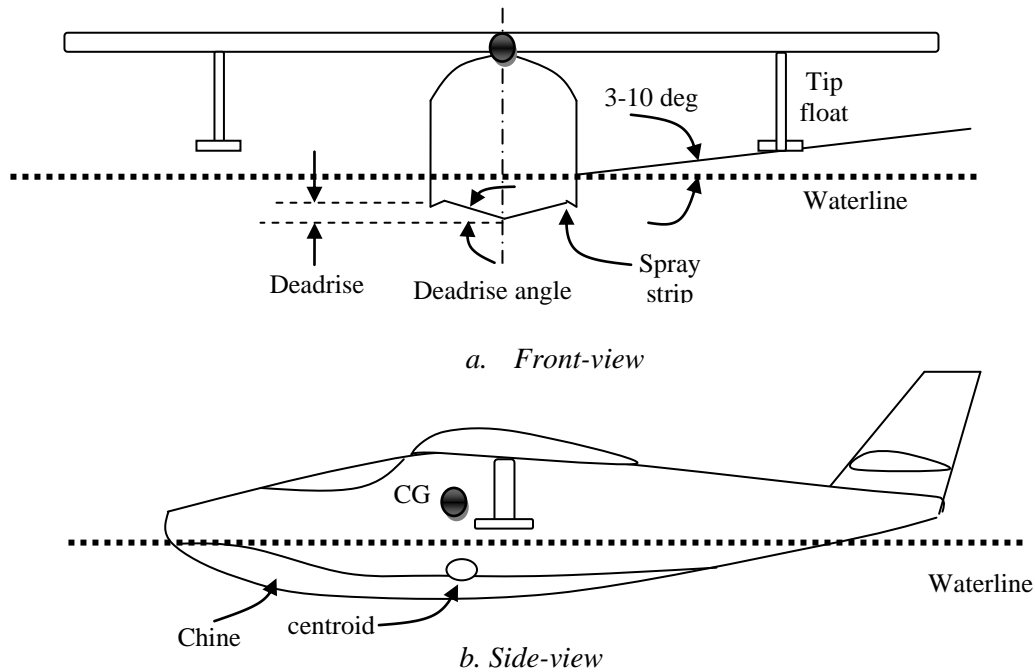

Figure 9.6. Sea-plane landing provision geometry

A sea-plane usually lands on the water first by its fuselage and then by utilizing a special skid to remain stable. The fuselage (or hull) bottom shape constitutes the primary part of a sea-plane landing gear. The fuselage shape must be designed to satisfy above-going requirements as well the fuselage original design requirements for accommodating payload. The slipping and the reduction of the water-impact load requirements often influence the design of the fuselage bottom shape, while the floating requirement affects the fuselage height. Lateral static stability on the water is usually provided by wing-mounted skids. These skids must be located such that they contact the water when the sea-plane tips sideways about less than 10 degrees.

One of the important variables in designing the fuselage bottom shape is water-line (see Figure 9.6) which is borrowed from ship dynamics. The purpose of a “load line” is to ensure that a ship (as in the sea-plane) has sufficient freeboard (i.e. the height from the water line to the main deck) and thus sufficient reserve buoyancy. The freeboard of sea vessels is measured between the lowest point of the uppermost continuous deck at side and the waterline and this must not be less than the allowable freeboard. The water line or load line indicates the legal limit to which a ship may be loaded. Any section of the aircraft under the waterline will submerge. The aircraft take-off/landing speed is determined by, amongst other parameters, the waterline length. The length of the waterline can change significantly as the vehicle heels, and can dynamically affect the speed of the vehicle.

A body in a fluid is buoyed up by a force equal to the weight of the fluid displaced. The buoyancy force (F_b) acts vertically upward through the centroid of the displaced volume. Thus the exact location of the load line is calculated using the Archimedes’ principle as follows:

$$F_b = \rho_f g V_d \quad (9.1)$$

where ρ_f is the density of the fluid (water has a density of 1000 kg/m^3), g is the gravity and V_d is the displaced volume of the fluid. The centroid of the area on the submerged volume should be close to the aircraft center of gravity.

The reduction of the water-impact load requirement may be satisfied by using a V-shaped bottom. The height of the V is referred to as the dead-rise, and the angle is the dead-rise angle. The dead-rise angle needs to be increased for higher landing speeds. Dead-rise angle is also increased toward the fuselage nose to about 40 degrees to better cut through water waves. To reduce water spray, spray strips may be applied to the edges of the bottom. The spray strips are usually angled about 40 degrees below the horizon.



Figure 9.7. *Firefighting amphibious JRV Canadair CL-215*

An important parameter that is strongly influencing the sea-plane performance during landing and take-off is the ratio between the waterline length (L_w) and fuselage width (W_f). Landing impact as well as the water-dynamic resistance are functions of this ratio (L_w/W_f). A wide fuselage has a lower water resistance, but suffers a higher landing impact. Figure 9.7 shows the seaplane JRV Canadair CL-215.



Figure 9.8. *A pilot during running to launch himself off the top of a hill aboard a hang glider*
(<http://photoexplorations.blogspot.com/>)

9.3.10. Human Leg

When an aircraft is very light and the cost is supposed to be as low as possible, human leg can function as a landing gear. This is the case for hang glider and paraglider. Pilot must use his/her leg to during take-off and landing operation. Due to human physical weaknesses, the landing speed must be very low (e.g. less than 10 knot) in order to have a safe landing. Pilot skill and nimbleness is a requirement besides the leg

for a successful landing. In such a case, there is no need for landing gear design; just assume that it has been designed and fabricated and is ready for flight. Figure 9.8 illustrates a pilot during take-off operation on board a hang glider (note his leg as a landing gear).

9.3.11. Landing Gear Configuration Selection Process

Now that several configurations of landing gear arrangements are introduced, it is time for describing how to select one to satisfy design requirements. Choice of landing gear depends upon a number of factors and one should not automatically assume that a nose gear (i.e. tricycle) is necessarily the best. There are several design requirements which affect the decision for selection of landing gear configuration. These include: cost, weight, performance, take-off run, landing run, ground static stability, ground taxi stability, and maintainability. In order to select the best landing gear configuration, the designer must perform a trade-off study using a comparison table such as Table 9.2. The candidate which gains the heist point is often the most appropriate landing gear for the aircraft. Hence based on aircraft mission and design requirements, one arrangement is usually the best alternative.

No		Single main	Bicycle	Tail-gear	Nose-gear	Quadricycle	Multi-bogey	Human leg
1	Cost	9	7	6	4	2	1	10
2	Aircraft weight	3	4	6	7	9	10	1
3	manufacturability	3	4	5	7	9	1	10
4	Take-off/landing run	3	4	6	10	5	8	2
5	Stability on the ground	1	2	7	9	10	8	5
6	Stability during taxi	2	3	1	8	10	9	-

Table 9.2. A comparison among various landing gear configurations (10: best, 1: Worst)

9.3.12. Landing Gear Attachment

When configuration of the landing gear is selected, the landing gear attachment must also be decided. Two primary options for the attachments are the fuselage and the wing. The attachment between landing gear and the aircraft will influences several design requirements, such as weight, take-off and landing performance, cost, and ground stability. A few main alternatives for the attachment between landing gear and the aircraft are usually as follows:

1. All struts/wheels are attached to the fuselage (e.g. F/A-18 (Fig 9.4-3); Boeing 747 (Fig 9.4-5)).
2. Main gears are attached to the wing, but the nose gear is attached to the fuselage (in a nose-wheel configuration).
3. Main gears are attached to the wing, but the tail gear is attached to the fuselage (in a tail-wheel configuration). An example is the WWII fighter aircraft P-51 Mustang (Fig 9.9a).
4. Main gears are attached to the nacelle, but nose gear is attached to the fuselage (in a nose-wheel configuration). A few examples are Boeing B-47 Stratojet (Fig 9.4-1), Cessna 340, and Cessna 421 (Figure 9.9b).

A natural option for the attachment is to attach the landing gear to the fuselage. However, there are cases that the designer should consider other alternatives. For instance, when the fuselage is not wide enough to allow for a long wheel track; the attachment to the wing will provide the solution. However, in the case of a high-wing configuration, the attachment of the landing gear to the wing makes the landing gear very long and heavy, as well as the retraction system to be hard to design. Another solution for an aircraft with a narrow fuselage is to accommodate a special bay for the landing gear retraction storage. This technique has been employed in the military aircraft cargo C-17 Globemaster (Figure 9.9c).



a. P-51 Mustang



b. Cessna 421



c. C-17 Globemaster

Figure 9.9. Landing gear attachments

In order to decide on the landing gear attachment, the designer must perform trade-off study using a comparison table. The fundamentals of the technique are introduced in Section 9.3.11.

In summary, the purpose of this section (9.3), has been to give the designer an overall understanding of the fundamental tradeoffs associated with different landing gear configurations. This understanding is helpful for discussions about landing gear design. In the subsequent sections, various aspects and parameters of landing gear will be examined and the relationships between landing gear parameters and the design requirements will be discussed.

9.4. Fixed, Retractable, or Separable Landing Gear

Another design aspect of the landing gear is to decide what to do with it after take-off operation. In general, there are four alternatives as follows:

1. Landing gear is released after take-off.
2. Landing gear hangs underneath the aircraft.
3. Landing gear is fully retracted inside aircraft (e.g. wing, or fuselage).
4. Landing gear is partially retracted inside aircraft.

Each of these four alternatives has various advantages and disadvantages which must be evaluated prior to decision making. In the first case, the landing gear is released after take-off; so the aircraft does not have to carry it during flight mission. Hence the aircraft weight will be reduced after take-off and it is assumed as an advantage. However, this alternative does not have anything to do with landing. It means that the aircraft is not supposed to land; which is the case for drones that are used as a target for missile test. Or, the aircraft must use another landing gear to land safely. Such wheels are sometimes mounted onto axles that are part of a separate dolly (for main wheels only) or trolley (for a three wheel set with a nose-wheel) chassis. The major advantage of such arrangement is the weight reduction which results in a higher performance. If the aircraft is planned to land at the end of its mission, this option is not recommended, since landing on a moving cart is not a safe operation. There is a very few number of aircraft with such landing gear configuration.

One of the longest-established jet target drones with a separable landing gear is the "*Jindivik*", developed in Australia, and used for decades in Britain and Australia. Over 400 were built, and small numbers were also supplied to the US Navy and to Sweden. The name is Aborigine for "that which is hunted". Development was begun in 1948 by the Australian Government Aircraft Factory. Figure 9.10 shows a Jindivik right after take-off. The aircraft utilizes a cart during take-off operation which is released after lift-off.

In the second, third, and fourth cases, the landing gear will be as a dead weight and has no positive function while aircraft in onboard. However, it is saved and employed during landing operation. Advantages and disadvantages of these two arrangements are compared in Table 9.3. In general, two major criteria are cost versus performance. If the primary design objective is higher performance, the

retractable landing gear is the best design. However, if the designer main concern is to reduce the aircraft cost, one way is to select a fixed landing gear. Currently all transport aircraft (such as Boeing 777 and Airbus 340) and most military aircraft (such as C-5, F-18, and F-16) and great portion of GA aircraft (e.g. Cessna 550, and Gulfstream IV) employ retractable landing gear. But most home-built aircraft and some GA aircraft (e.g. Cessna 172) have fixed landing gear. Figure 9.2 illustrates a few examples. If a retractable landing gear needs to be compromised to provide internal volume to other components such as fuel, a partially retractable landing gear is the solution. For instance, close support military aircraft A-10 feature a partially retractable landing gear in order to provide a larger room for stores.



Figure 9.10. Aircraft Jindivik releases landing gear after take-off (<http://www.militaryimages.net>)

In the case of a retractable landing gear, it folds after takeoff into the fuselage where it is stored during flight until shortly before landing. Related features of a retractable landing gear are: 1. Retracting system design, 2. Provision of sufficient room for landing gear after retraction. Most mechanisms for landing gear retraction system are based upon a four-bar linkage, by using three members connected by pivots. The fourth bar is the aircraft structure. A retraction mechanism clearly increases aircraft weight, design complexity, and maintenance; and reduces the internal fuel volume.

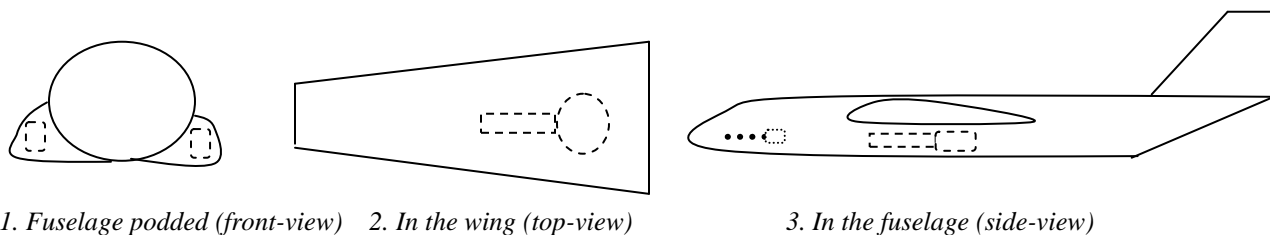

Figure 9.11. Landing gear storage bay

Major options for main landing gear home (see Fig. 9.10) are: 1. In the wing, 2. In the fuselage, 3. Wing-podded, 4. Fuselage-podded, 5. Wing-fuselage junction, and 6. In the nacelle. In a high-wing configuration, retracting and locating landing gear in the fuselage makes the strut shorter. In general, a retracted position inside aircraft will chop up aircraft structure which consequently increases aircraft weight. The examples are locating the landing gear in the wing, in the fuselage, on in the wing-fuselage. On the other hand, a podded bay configuration tends to increase aircraft frontal area that causes additional aerodynamic drag. The example is locating the landing gear in a pod beside fuselage. In terms of aircraft

structural design complexity, a landing gear bay in the wing requires a wing cutout that leads in stronger spars. The best candidate for a bay in the wing is the room between main spar and rear spar. A landing gear bay in the fuselage also requires a fuselage cutout that leads in stronger frames and longerons. The aerodynamic benefits of in the wing or in the fuselage bay arrangements outweigh the drawbacks for high-speed aircraft.

Most low wing transport aircraft (such as Boeing 767 and Airbus 320) retract the main gear into the wing-fuselage junction, while most high wing transport (cargo) aircraft retract the main gear into the fuselage. Most fighters (such as F-16 Falcon and F-18 Hornet) with low wing configuration retract the main gear and also nose wheel into the fuselage. Some GA aircraft retract the main gear into the wing (e.g. Cessna 525), while some GA aircraft (e.g. Learjet 85) into the wing-fuselage junction. The fuselage-podded or wing-podded landing gear bay reduces the aircraft weight significantly since the fuselage and wing structure is uncut. The close support aircraft A-10 Thunderbolt have a wing-podded landing gear configuration due to its military mission requirements. In the case of a twin propeller-driven engine aircraft with main gears underneath the engines (e.g. P-38 Lightning), a typical location for main gear bay is the nacelle behind the engines. A retractable landing gear bay normally requires a couple of doors to be closed after retraction in order to reduce the drag. In some aircraft such as Boeing 737-700, main wheels are retracted into the fuselage bay without any landing gear door to save weight.

No	Item	Fixed (unretractable) Landing Gear	Retractable Landing Gear
1	Cost	Cheaper	Expensive
2	Weight	Lighter	Heavier
3	Design	Easier to design	Harder to design
4	Manufacturing	Easier to manufacture	Harder to manufacture
5	Maintenance	Easier to maintain	Harder to maintain
6	Drag	More drag	Less drag
7	Aircraft performance	Lower aircraft performance (e.g. maximum speed)	Higher aircraft performance (e.g. maximum speed)
8	Longitudinal stability	More stable (stabilizing)	less stable (destabilizing)
9	Storing bay	Does not require a bay	Bay must be provided
10	Retraction system	Does not require a retraction system	Requires a retraction system
11	Fuel volume	More available internal fuel volume	Less available internal fuel volume
12	Aircraft structure	Structure in un-interrupted	Structural elements need reinforcement due to cutout

Table 9.3. Fixed and retractable landing gear comparison

A technique to reduce a fixed landing gear drag is to employ fairing (see Figure 9.11). Fairing is a special airfoil-shape cover which mainly covers the wheel. As a rule of thumb, a well-designed fairing will reduce the wheel drag by as much as 1000%. Thus an unfaired wheel (see Figure 9.4-3) will generate about 10 times more drag than a faired wheel. However, the landing gear wheels generate approximately 5% of the aircraft total drag; hence the application of wheel fairing will reduce the aircraft total drag by as much as only 4.5%.



Figure 9.12. RV-6, N96FS, with the landing gear fairings
(<http://picasaweb.google.com/lh/photo/1WDAfQ8oTdcM1tuSqvQ47A>)

9.5. Landing Gear Geometry

At this point, the landing gear configuration is selected and retraction configuration is decided. Now, the designer needs to perform mathematical calculations to determine few parameters such as height, wheel base, wheel track, and the distance between main gear and aircraft center of gravity. These parameters are interrelated through geometrical relations and several mathematical principles. These relationships are described in this Section. The guidelines for determining these parameters are presented in the following subsequent sections.

9.5.1. Landing Gear Height

9.5.1.1. Definition of Height

Landing gear height (H_{LG}) is defined as the distance between the ground and the conjunction between main gear strut and the aircraft structure. Figure 9.13 illustrates several aircraft with different landing gear height cases. The main gear may be attached to the fuselage (Fig. 9.13-1), wing (Fig. 9.13-2), or nacelle (Fig. 9.13-4). The connection might be through variety of ways including strut (Fig. 9.13-2), solid spring (Fig. 9.13-1), solid axle (Fig. 9.13-6), rubber bungee (Fig. 9.13-5), hinge, or oleo (Fig. 9.13-4). Hence, the landing gear height could be shorter when the aircraft is on the ground due to the spring deflection or oleo compression because of the aircraft weight. In order to have a uniform definition, the landing gear height is measured when the aircraft is on the ground and the fuselage is horizontal.

The tires themselves provide some kinds of shock absorbing ability by deflection when a bump is encountered. The aircraft with rigid axle are relying solely upon the tires for shock absorbing. There are mainly five design requirements in which landing gear height play an important role. They are:

1. Landing gear height provides aircraft clearance during taxi.
2. Landing gear height provides rear fuselage clearance during take-off rotation.
3. Landing gear height contributes to tip-back prevention.
4. Landing gear height contributes to overturn prevention.
5. Landing gear height satisfies loading and unloading requirements.

In the early stages of design, it is not clear which of the above requirements is the most critical one. Thus, the designer should examine all five requirements to make sure that the landing gear height does not violate any of these requirements.

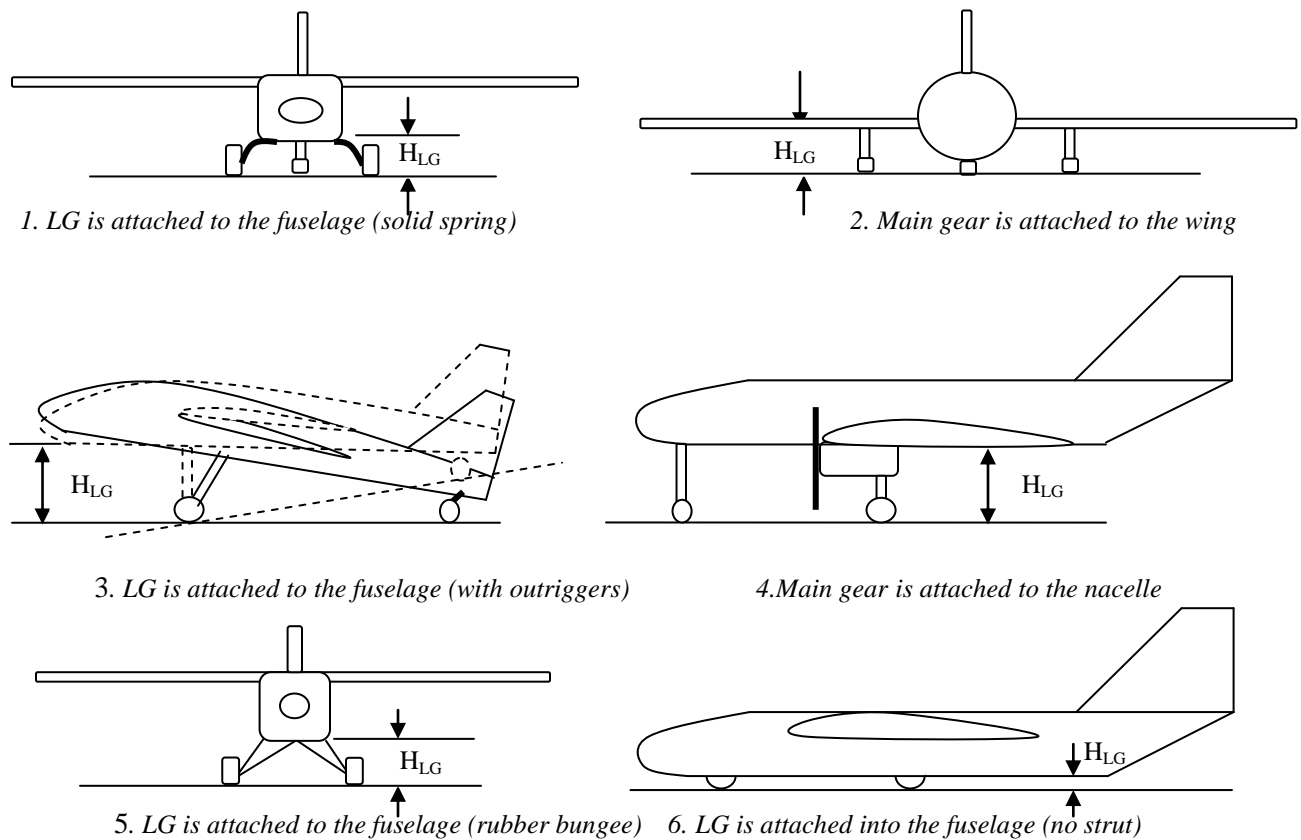

Figure 9.13. Landing gear height in various aircraft configurations

9.5.1.2. Aircraft General Ground Clearance Requirement

One of the primary functions of the landing gear is to protect the aircraft structure from the ground. This job is performed by providing a clearance with the ground. The clearance is measured from the lowest point of the aircraft to the ground. In some aircraft, the lowest component is the wing (e.g. low wing); while in some aircraft is the fuselage (e.g. high wing), and in some other aircraft, the jet engine has the lowest height from the ground (e.g. a transport aircraft with engines hang underneath the low wing). In the case of an aircraft with prop-driven engine(s), the prop tip is often the lowest point. In any case, a clearance needs to be provided via the landing gear height. The minimum magnitude of the clearance is a function of several design parameters including cost, safety, performance, weight, stability, engine inlet, loading, and operational requirements.

For an aircraft with one piston-prop engine, the typical value for the prop ground clearance is about 20 cm. For an aircraft with jet engine(s), the inlet must be high enough such that the sand or debris is not pulled into the engine inlet during take-off. The inlet height is a function of aircraft speed and engine thrust. A typical value for the inlet height of a jet engine with a 50 kN of thrust is about 70 cm. figure 9.13 illustrates several aircraft configurations with various clearances. For a transport aircraft with prop-driven engine(s), the recommendation is to provide a prop clearance as much as the height of a human (about 180 cm). This safety initiative avoids the possible accident of a human being hit by a rotating prop while moving around the aircraft.

No	Aircraft Components	Clearance (m)	Remarks
1	Fuselage	0.2–1.2	
2	Rear fuselage	0.2–0.5	During take-off rotation
3	Wing	0.2–1.5	Includes flap clearance
4	Turbofan/turbojet engine	0.5–1.5	Inlet clearance
5	Propeller (piston or turboprop) –landplane	0.2–1	Tip clearance
6	Propeller (piston or turboprop) –seaplane	1–2	Tip clearance
7	Store/fuel tank/pitot tube/antenna/probe	0.2–0.6	

Table 9.4. Recommended clearance for various aircraft components

The clearance for various aircraft components is recommended in Table 9.4. The recommended clearance has a range of values due to the fact that aircraft type, aircraft mission, aircraft speed, type of runway and cost dictates some limits. For instance a very light remote controlled aircraft requires a much smaller clearance (say 20 cm) compared with a very large civil transport aircraft (say 1 m). Furthermore, a large military cargo aircraft, such as cargo aircraft C-17 (fig 9.9-c) requires much smaller clearance (say 30 m) due to the loading requirements.

9.5.1.3. Take-off Rotation Ground Clearance Requirement

An aircraft is usually rotating about the main gear in order to increase the lift to prepare for take-off (See Fig. 9.14). This is also true for landing operation in which the aircraft rotates to gain high angle of attack. In an aircraft with non-tail-gear, the height of the landing gear must be set so that the tail or rear fuselage does not hit the ground during the take-off or rotation or landing high angle of attack. However, in practice, transport aircraft are provided with removable shields that protect the fuselage from hitting the ground, due to the fact that some unskilled pilots rotate the aircraft so fast that rear fuselage hits the ground. These rear fuselage protective shields are replaced on a regular base.

This accident must be prevented through an increase in the landing gear height. Another common solution to this problem is to cut the rear fuselage by an upsweep angle. The occurrence of the hit is examined by looking at the angle between ground and the line passing from the main gear contact with ground) to the beginning of upsweep angle at the fuselage (i.e. α_C). The take-off rotation ground clearance requirement to prevent a fuselage hit is as follows:

$$\alpha_C \geq \alpha_{TO} \quad (9.2)$$

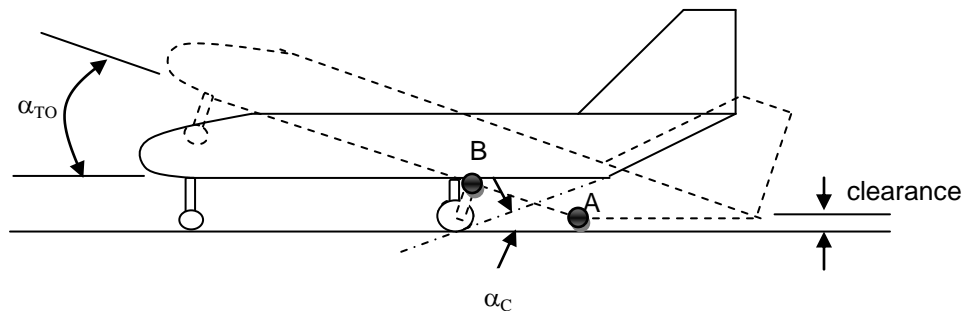

Figure 9.14. Take-off rotation and rear fuselage clearance

where the clearance angle is:

$$\alpha_C = \tan^{-1}\left(\frac{H_f}{AB}\right) \quad (9.3)$$

In another word, if the clearance angle (α_C) is less than the aircraft rotation angle (α_{TO}) during take-off, the fuselage will hit the ground. Otherwise, there will be a clearance between fuselage and the ground and the fuselage will not be damaged during the take-off rotation. The magnitude clearance could be determined by examining the triangle (Fig. 9.15) which is comprised of three sides: 1. the distance aft of main gear to the beginning of upsweep angle (i.e. AB); 2. fuselage height (H_f); and 3. take-off rotation angle (α_{TO}). Figure 9.15 shows the triangle ABC (part of the aircraft in Fig. 9.14) that is formed between the fuselage lower surface and the main gear. The aircraft is rotated about the main gear (O or C) with the amount of take-off rotation angle. The minimum clearance between fuselage and the ground (H_C) during take-off rotation is about 30 cm. Example 9.1 illustrates the application of this triangle to determine the acceptability of the main gear height regarding this requirement. If the clearance H_C is determined to be negative or below the limit, the main gear height needs to be increased accordingly.

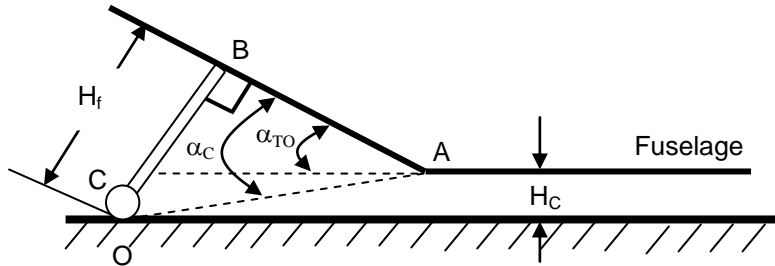

Figure 9.15. Examination of rear fuselage clearance during take-off rotation

Example 9.1

A pilot of the following jet aircraft is going to take-off with 12 degrees of fuselage angle of attack. Determine if the aircraft rear fuselage will hit the ground during take-off rotation. If yes, what must be the main gear height to achieve the clearance of 30 cm?

Solution:

First, we need to determine the clearance angle:

$$\alpha_C = \tan^{-1}\left(\frac{H_f}{AB}\right) = \tan^{-1}\left(\frac{1}{5}\right) = 0.197 \text{ rad} = 11.31 \text{ deg} \quad (9.3)$$

Since the clearance angle is less than fuselage rotation angle (12 deg), the fuselage will hit the ground during take-off rotation.

Next a new value for main gear height must be determined to prevent the occurrence of the fuselage hit. Since the aircraft take-off rotation angle is 12 degrees, we tentatively consider an angle of 12 degrees to prevent the hit.

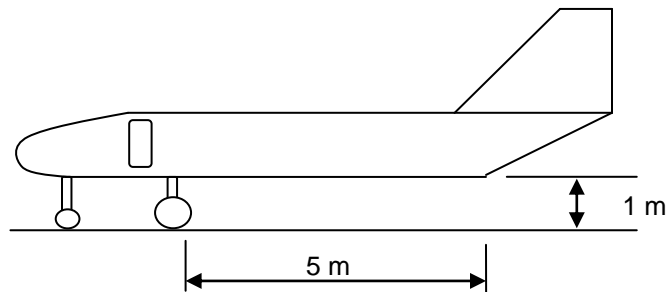

Figure 9.16. Figure for Example 9.1

$$\alpha_C = \tan^{-1}\left(\frac{H_f}{AB}\right) \Rightarrow 12 \text{ deg} = \tan^{-1}\left(\frac{H_f}{5}\right) \Rightarrow H_f = 5 \times \tan(12 \text{ deg}) = 1.063 \text{ m} \quad (9.3)$$

When the landing gear height is 1.063 m, the fuselage is about to have the contact with the ground. Any landing gear height higher than 1.063 m (say 1.1 m) guarantees that the fuselage will not hit the ground during the 12 degrees of take-off rotation.

9.5.2. Wheel Base

Wheel base (B) plays an important role on the load distribution between primary (i.e. main) gear and secondary (e.g. nose, or tail) gear. This parameter also influences the ground controllability and ground stability. Thus, the wheel base must be carefully determined and an optimum value needs to be calculated to ensure it meets all relevant design requirements. In this section, the load distribution between main and nose gear is examined. The effect of wheel base on the ground controllability and ground stability will be discussed in the subsequent sections.

Figure 9.17 shows a stationary aircraft with a tricycle landing gear on the ground. The aircraft weight (W) is carried by three wheels (i.e. two main and one nose gear). Due to the ground controllability requirement, typically the nose gear must not carry less than about 5 percent of the total load and also must not carry more than about 20 percent of the total load (e.g. aircraft weight). Thus, main gear carries about 80% to 95% of the aircraft load. Therefore nose wheel could be much smaller than the main wheels. This is true for the comparison between nose strut and main struts. The loads on nose and main gears are denoted by F_n and F_m respectively. These data are employed in early preliminary design of landing gear.

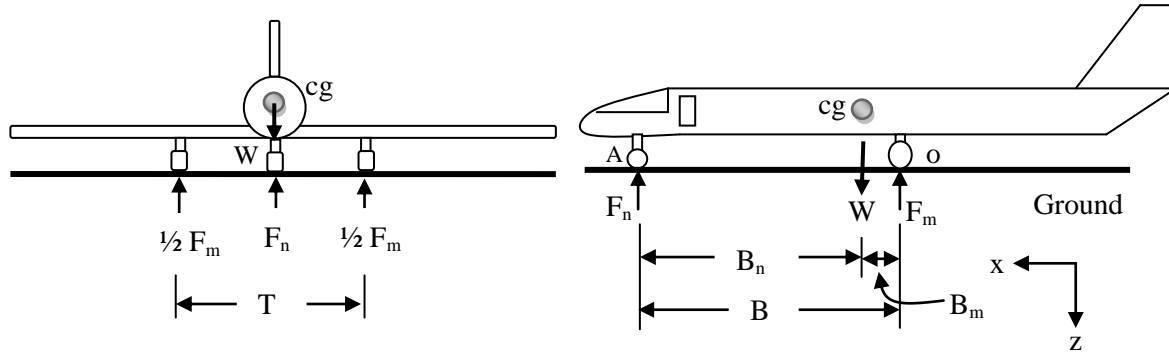

Figure 9.17. Wheel load geometry

Calculation of the static loads on each gear is performed by employing equilibrium equations. Since the aircraft is in static equilibrium, the summation of all forces in z direction must be zero:

$$\Sigma F_z = 0 \Rightarrow F_n + F_m = W \quad (9.4)$$

Furthermore, the summation of all moments about o is zero:

$$\Sigma M_o = 0 \Rightarrow F_n B - W B_m = 0 \quad (9.5)$$

Thus the percentage of the static load (i.e. aircraft weight) which is carried by the nose gear is:

$$F_n = \frac{B_m}{B} W \quad (9.6)$$

In addition, the percentage of the static load which is carried by the main gear is:

$$F_m = \frac{B_n}{B} W \quad (9.7)$$

In the case of a tricycle landing gear, the load on the main gear is divided between left and right gear, so each wheel will carry one half of the main gear load (i.e. $\frac{1}{2} F_m$). The wheel bases for several aircraft are tabulated in Table 9.5.

Example 9.2

A GA aircraft with a mass of 5,000 kg has a tricycle landing gear configuration. The wheel base and wheel track is 10.2 m and 1.8 m respectively and the distance between main gear to aircraft cg is 0.84 m. Determine the static load on each gear. What percentage of the aircraft weight is carried by nose gear?

Solution:

$$\Sigma M_o = 0 \Rightarrow W_{TO} (0.84) - F_{nose} (10.2) = 0 \Rightarrow F_{nose} = \frac{W_{TO}}{10} = \frac{5000 \times 9.81 \times 0.84}{10.2} = 4038 \text{ N}$$

$$\Sigma F_z = 0 \Rightarrow F_{main} + F_{nose} = W_{TO} \Rightarrow F_{main} = W_{TO} - F_{nose} = 5000 \times 9.81 - 4038 = 44,995.2 \text{ N}$$

$$\frac{F_{nose}}{W_{TO}} = \frac{4038}{5000 \times 9.81} = 0.0824 = 8.24\%$$

Thus, 8.24 percent of the aircraft weight is carried by the nose gear.

The above-mentioned relationships are applicable only in static situations. There are two other interesting conditions that cause landing gear to experience different loadings: 1. change in the aircraft center of gravity location; 2. dynamic loading. Due to the possibility of a change in the load distribution, or having different combination of cargo, or number of passengers, the gears must carry a load other than the nominal static load. In the x-axis, an aircraft center of gravity is allowed to move between two extreme limits: a. most aft location ($X_{cg_{aft}}$), and b. most forward location ($X_{cg_{for}}$). Figure 9.18 illustrates a tricycle configuration with most aft and most forward cg locations. The following equations govern the minimum and maximum static loads on each gear:

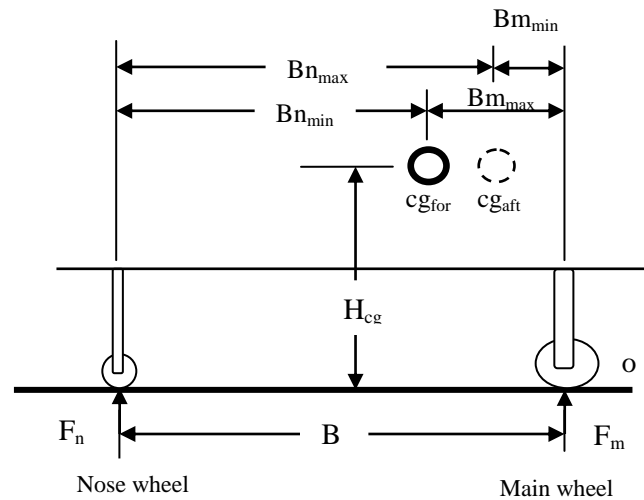

Figure 9.18. Wheel load geometry

$$F_{m_{max}} = \frac{B_{n_{max}}}{B} W \tag{9.8}$$

$$F_{n_{max}} = \frac{B_{m_{max}}}{B} W \tag{9.9}$$

$$F_{m_{min}} = \frac{B_{n_{min}}}{B} W \tag{9.10}$$

$$F_{n_{\min}} = \frac{B_{m_{\min}}}{B} W \quad (9.11)$$

Furthermore, landing gear tends to experience a dynamic loading due to aircraft acceleration and deceleration during take-off and landing. The nose gear will have to carry a dynamic loading during the landing operation when aircraft is braking. During braking segment of the landing operation, the following equilibrium equation may be written (see Fig. 9.17):

$$\Sigma M_o = 0 \Rightarrow F_n B - WB_m - \frac{W}{g} |a_L| H_{cg} = 0 \quad (9.12)$$

where “ a_L ” is the braking deceleration and “ g ” is the gravitational acceleration. Therefore the nose gear load is:

$$F_n = W \frac{B_m}{B} + \frac{W |a_L| H_{cg}}{gB} \quad (9.13)$$

The first term of equation 9.13 is the static load, but the second term is referred to as the dynamic loading:

$$F_{n_{dyn}} = \frac{|a_L| WH_{cg}}{gB} \quad (9.14)$$

Hence the total load on the nose gear during landing will be:

$$F_n = F_{n_{\max}} + F_{n_{dyn}} \quad (9.15)$$

To insure the ground controllability in a tricycle landing gear configuration, the parameter $B_{m_{\min}}$ should be greater than 5 percent of wheel base and the parameter $B_{m_{\max}}$ should be less than 20 percent of the wheel base. These equations and requirements are employed to determine wheel base plus the distance between cg and nose gear, and cg and main gear. With a similar approach, the dynamic loading on the main gear during take-off acceleration with an acceleration of a_T will be determined as follows:

$$F_{m_{dyn}} = \frac{a_T WH_{cg}}{gB} \quad (9.16)$$

Thus, the total load on the main gear is:

$$F_m = F_{m_{\max}} + F_{m_{dyn}} = W \frac{B_{m_{\max}}}{B} + \frac{Wa_T H_{cg}}{gB} \quad (9.17)$$

These static and dynamic loadings are utilized in determining nose and main gears locations, strut load, and wheel and tire design. It must be noted that the main gear is usually carrying a total load which is greater than the aircraft weight.

Example 9.3

A small business jet aircraft with a mass of 6,500 kg has a tricycle landing gear configuration with a wheel base is 8 m. The aircraft cg is allowed to move between 7.1 m to 6.5 m from the nose gear.

- The nose gear is desired to carry a maximum of 15% of the aircraft weight in static equilibrium, determine wheel base.
- The deceleration during landing brake is -3 m/s^2 and the acceleration during take-off is 4 m/s^2 . The distance between aircraft cg to the ground is 2 m. Determine the maximum load on each gear.

Solution:

-

$$F_{n_{\max}} = \frac{B_{m_{\max}}}{B} W \Rightarrow B = B_{m_{\max}} \frac{W}{F_{n_{\max}}} = (B - 6.5) \frac{W}{0.08W} = \frac{B}{0.15} - \frac{6.5}{0.15} = 6.667B - 43.333 \quad (9.9)$$

$$\Rightarrow B = 7.647 \text{ m}$$

b.

Maximum load on nose gear will be during landing brake.

$$B_{m_{\max}} = B - B_{n_{\min}} = 7.647 - 6.5 = 1.147 \text{ m}$$

$$F_n = F_{n_{\max}} + F_{n_{\text{dyn}}} = W \frac{B_{m_{\max}}}{B} + \frac{W|a_L|H}{gB} = 6500 \times 9.81 \times \frac{1.147}{7.647} + \frac{6500 \times 9.81 \times 3 \times 2}{9.81 \times 7.647} \Rightarrow$$

$$F_n = 14661.5 \text{ N} \quad (9.13)$$

It is interesting to note that this load is 23 percent of the aircraft weight. Maximum load on the main gear will be during take-off acceleration.

$$F_m = F_{m_{\max}} + F_{m_{\text{dyn}}} = W \frac{B_{n_{\max}}}{B} + \frac{W a_T H_{cg}}{gB} = 6500 \times 9.81 \times \frac{7.1}{7.647} + \frac{6500 \times 9.81 \times 4 \times 2}{9.81 \times 7.647} \quad (9.17)$$

$$\Rightarrow F_m = 65983.1 \text{ N}$$

It is interesting to note that this load is 103.5 percent of the aircraft weight. This implies that the main gear during take-off has to carry a total load which is 3.5 percent greater than the aircraft weight.

9.5.3. Wheel Track

Wheel track (T) is defined as the distance between the most left and the most right gears (when looking at front-view) and is measured at the ground (Figure 9.1). Three main design requirements which drive the magnitude of this parameter are: 1. Ground lateral control, 2. Ground lateral stability, and 3. Structural integrity. The wheel track of the main wheel should be arranged so that the aircraft cannot roll over too easily due to wind or during a ground turn. Some aircraft such as British single-seat fighter aircraft of WW II Supermarine Spitfire were critical in this regard. To determine wheel track, the overturn angle is introduced. The overturn angle is the angle which is critical to the aircraft overturn. There are two overturn angles (Fig 9.19); in that the smaller one is considered in this technique.

1. When looking at the aircraft front-view, the angle between the vertical line passing through the aircraft cg and the line between aircraft cg and the one of the main wheels is the overturn angle (Figure 9.19-2). In this figure, the parameter H_{cg} is the height of aircraft cg from the ground.
2. When looking at the aircraft top-view, first, draw a line passing through the aircraft one of the main gears (say left one) and the nose gear. Then, draw a parallel line to this line passing through the aircraft cg. The next step is to form a triangle by selecting a distance on this line equal to the length of H_{cg} (see Figure 9.19-1), and draw a line perpendicular to this point. The last step is to pass a line from the intersection of the last line from aircraft cg. The overturn angle is formed by this line as shown.

As a rule of thumb, the wheel track must be such that the overturn angle; Φ_{ot} is inside the following recommended limit:

$$\Phi_{ot} \geq 25^\circ$$

$$(9.18)$$

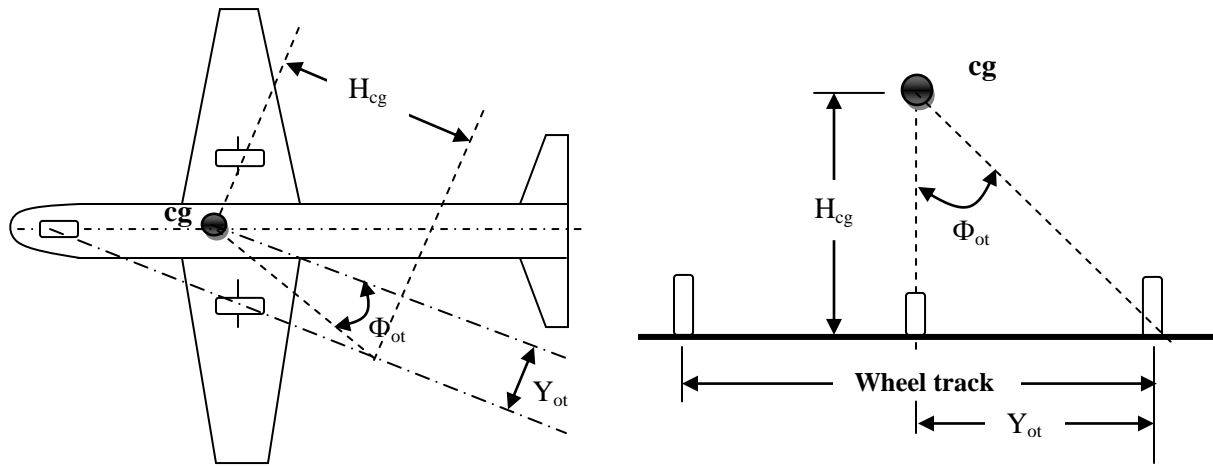

1. Φ_{ot} based on top-view

2. Φ_{ot} based on front-view

Figure 9.19. Overturn angle

For an accurate determination of the wheel track, three design requirements of 1. Ground lateral control, 2. Ground lateral stability, and 3. Structural integrity must be examined as explained in the following subsections. The minimum allowable value for the wheel track must satisfy the overturn angle requirements (Section 9.5.3.1). The maximum allowable value for the wheel track must satisfy the structural integrity requirements (Section 9.5.3.2). The wheel tracks for several aircraft are tabulated in Table 9.5.

9.5.3.1. Overturn Angles Requirement

One of the influencing requirements on the design of landing gear is the overturn angle requirement. This requirement sets minimum and maximum limits for the wheel track. In general, there are two disturbing moments which are able to overturn an aircraft: 1. Centrifugal force in a ground turn, 2. Cross wind force. The first force is addressed in ground controllability requirement, while the second one is examined in the ground stability requirement. The wheel track; or overturn angle contributes to meeting these two design requirements in two separate ways.

1. Ground controllability

The wheel track must be large enough such that the aircraft is not rolled over during a ground turn taxi. The force that may roll over the aircraft is the centrifugal force (F_C) which is created during a turn due to centripetal acceleration.

$$F_C = m \frac{V^2}{R} \tag{9.19}$$

where m represents the aircraft mass, V is the aircraft ground speed, and R is the radius of turn (See Fig 9.20-1). The force to prevent the overturn is the aircraft weight. The two contributing moments into an overturn is the moment of the centrifugal force and the moment of the aircraft weight (Fig. 9.20-2). The restoring moment of the aircraft weight is a function of wheel track. The summation of the two contributing moments about the outer main gear is as follows:

$$\sum M_o = 0 \Rightarrow W \cdot Y_{ot} + F_C \cdot H_{cg} = 0 \quad (9.20)$$

Thus:

$$Y_{ot} = \frac{F_C \cdot H_{cg}}{mg} \quad (9.21)$$

Therefore the wheel track must be:

$$T > 2 \frac{F_C \cdot H_{cg}}{mg} \quad (9.22)$$

For the triangle in Figure 9.20-2, we can write:

$$\tan(\Phi_{ot}) = \frac{Y_{ot}}{H_{cg}} \quad (9.23)$$

Hence, the overturn angle must be:

$$\Phi_{ot} > \tan^{-1} \left(\frac{\frac{F_C \cdot H_{cg}}{mg}}{H_{cg}} \right) \Rightarrow \Phi_{ot} > \tan^{-1} \left(\frac{F_C}{mg} \right) \quad (9.24)$$

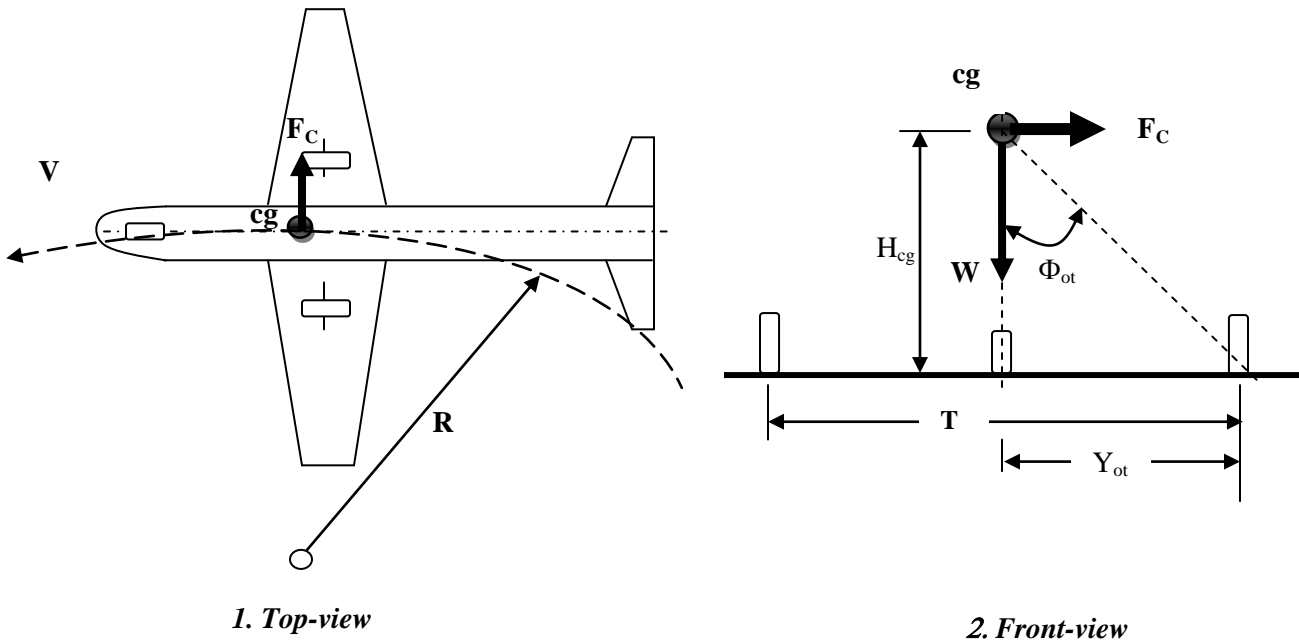

Figure 9.20. An aircraft in a ground turn and overturn contributing factors

Thus, the wheel track (T) is playing an important role in the aircraft ground controllability. It must be large enough to prevent the aircraft to roll over during a ground turn. The critical condition is when the aircraft has the lowest possible weight.

Example 9.4

A twin engine jet transport aircraft with a mass of 60,000 kg and a wing area of 100 m² is turning on a runway. The ground speed is 20 knot and the turn radius is 30 m. The height of the aircraft center of gravity from the ground is 3.5 m.

- Determine minimum overturn angle to prevent an overturn in this taxi maneuver.
- Determine the wheel track corresponding to this overturn angle.

Solution:

a.

$$F_C = m \frac{V^2}{R} = 60000 \times \frac{(20 \times 0.5144)^2}{30} = 211722.6 \text{ N} \quad (9.19)$$

$$\Phi_{ot} = \tan^{-1} \left(\frac{F_C}{mg} \right) = \tan^{-1} \left(\frac{211722.5}{60000 \times 9.81} \right) = 0.345 \text{ rad} = 23 \text{ deg} \quad (9.24)$$

Thus any overturn angle greater than 23 degrees will prevent the aircraft to overturn in this taxi maneuver.

b.

$$T = 2 \frac{F_C \cdot H_{cg}}{mg} = 2 \times \frac{211722.5 \times 3.5}{60000 \times 9.81} = 2.52 \text{ m} \quad (9.22)$$

The wheel track corresponding to this overturn angle is 2.52 m.

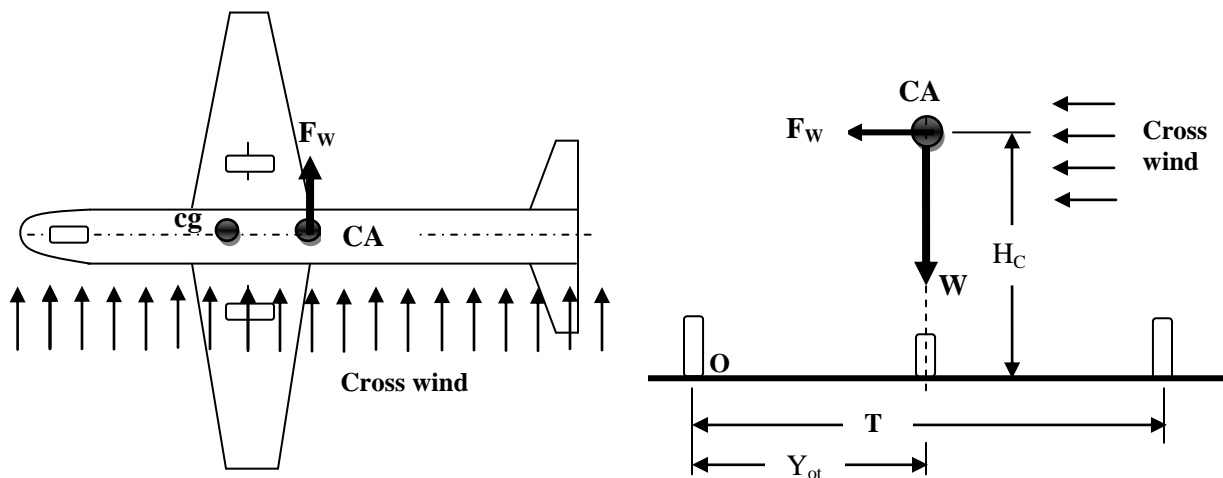

1. Top-view

2. Front-view

Figure 9.21. An aircraft in a ground turn and overturn contributing factors

2. Ground Stability

One of the atmospheric phenomena that is affecting the aircraft ground stability is the wind. The most noticeable wind on an aircraft at the ground is the cross wind where it is perpendicular to the aircraft ground path or fuselage centerline. A cross wind is creating a force on an aircraft at the ground which in turn generates a moment which is capable of overturning the aircraft. The restoring moment is the aircraft weight times its corresponding arm (a half of the wheel track). Thus, the wheel track (T) is playing an important role in the aircraft ground stability. It must be large enough to prevent the aircraft to roll over when on the ground due to a cross wind.

Figure 9.21 illustrates an aircraft on the ground with a cross wind. Whenever a cross wind is blowing, it will create a force (F_w) which is applied on the of aircraft side area (Fig 9.22). The centroid of aircraft side area (CA) may be obtained by integrating over the side area from nose to the tail. The details of the technique are well introduced in any Statics textbook (e.g. Ref. 3). In figure 9.21 or 9.22, H_C is the height of the centroid from the ground.

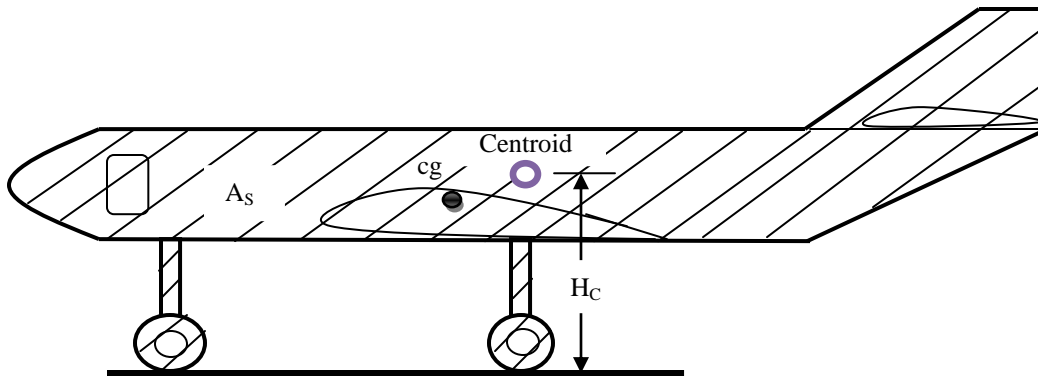

Figure 9.22. Aircraft side area and its centroid

The cross wind force (F_w) on an aircraft may be modeled as a drag force and is calculated as follows:

$$F_w = \frac{1}{2} \rho V_w^2 A_s C_{D_s} \quad (9.25)$$

where V_w represents the wind speed, A_s represents the aircraft side area (hatching area in Fig 9.22). The parameter C_{D_s} is called the aircraft side drag coefficient and its value varies between 0.3 to 0.8. For the exact value of C_{D_s} you may consult with Fluid Mechanics textbooks.

To prevent an aircraft from overturning by the cross wind, the moment of the aircraft weight must be greater than the moment of the wind force (See fig 9.21-2). Taking the moment about the left main gear yields:

$$\sum M_O = 0 \Rightarrow W \cdot Y_{ot} + F_w \cdot H_C = 0 \quad (9.26)$$

Thus:

$$Y_{ot} = \frac{F_w \cdot H_C}{W} \quad (9.27)$$

Hence the wheel track must be greater than twice the value of this Y_{ot} in order for an aircraft to be stable on the ground in case of a cross wind.

$$T > 2Y_{ot} \quad (9.28)$$

Please note that the critical condition is when the aircraft has the lowest possible weight and the runway is located at sea level altitude. In majority of aircraft cases, satisfaction of the ground controllability automatically meets than ground stability requirement.

Example 9.5

Consider the aircraft in Example 9.4 is on a runway at sea level altitude. The aircraft side area is 150 m², and the height of the aircraft centroid of side area from the ground is 3.6 m. A cross wind with a speed of 50 knot is blowing. Assume the aircraft side drag coefficient is 0.8. Determine the minimum wheel track to prevent an overturn due to this cross wind. The lowest possible weight is 40000 kg when there is no passenger on-board and zero fuel.

Solution:

$$F_w = \frac{1}{2} \rho V_w^2 A_s C_{D_s} = 1 \times 1.225 \times (50 \times 0.5144)^2 \times 150 \times 0.8 = 48,630 \quad N \quad (9.25)$$

$$Y_{ot} = \frac{48,630 \times 3.6}{40000 \times 9.81} = 0.446 \quad m \quad (9.27)$$

$$T > 2Y_{ot} = 2 \times 0.446 = 0.893 \quad m \quad (9.28)$$

Therefore, the minimum wheel track for this aircraft to avoid a roll over due to this cross wind is 0.9 m.

9.5.3.2. Structural Integrity

The previous section introduced the technique to obtain a minimum value for the wheel track to avoid a roll over. Another limit for the wheel track is the maximum value which is presented in this section. The maximum value for the wheel track is limited by the aircraft structural integrity requirement. When looking at an aircraft from front-view, the aircraft structure may be viewed as a beam with a few simple supports (Fig. 9.23). In an aircraft with a tricycle configuration, at the main gear station, the beam is the wing and two simple supports are two main gears. Thus the wheel track is another name for the distance between two supports.

Based on basic theory of structural engineering, a beam with two simple supports will deflect. The maximum deflection (y_{max}) will be at the middle of the beam. As the distance between two supports is increased (i.e. wheel track increases), the beam deflection will increase too. The limiting factors for this deflection (i.e. wheel track) are as follows:

1. An increase in the wheel track will be translated as an increase in the wing dihedral; which in turn degrades the aircraft lateral stability and roll control.
2. An increase in the wheel track will cause the fuselage to deflect down, and in the worst case fuselage may touch the ground.
3. An increase in the wheel track may degrade the aircraft structural integrity, aerodynamic integrity, and in the worst case, the structure may break.

As soon as we know the allowable deflection for the structure at the main wheel station, the wheel track is obtained.

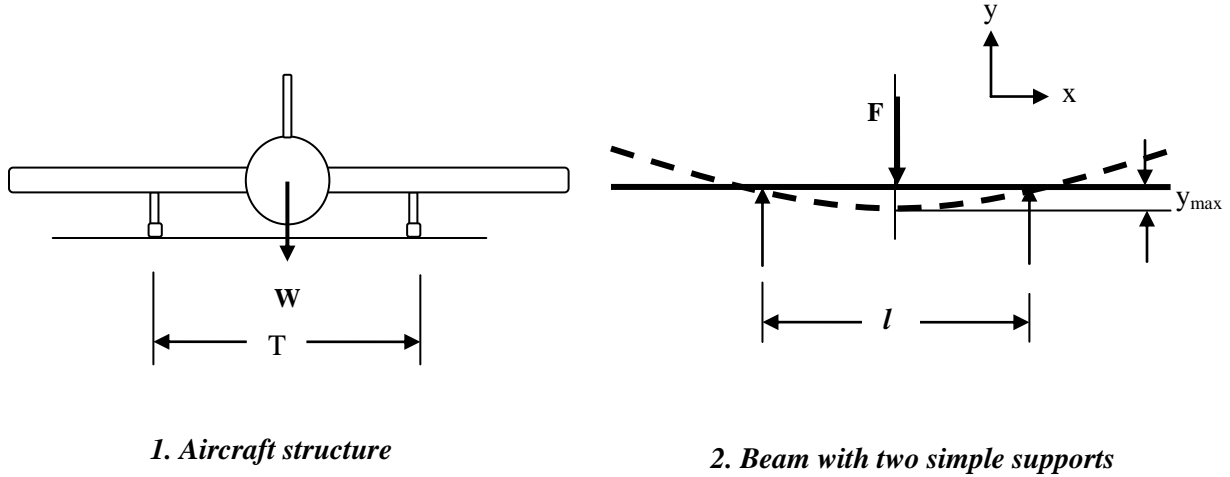

Figure 9.23. The aircraft structure at front view may be modeled as a beam with two simple supports

The maximum deflection (y_{\max}) in a beam with a force F at the middle of the beam (Fig 9.23-2) is determined (Ref. 4) as follows:

$$y_{\max} = -\frac{Fl^3}{48EI} \quad (9.29)$$

where E is the modulus of elasticity and I is the second moment of the area of the beam. This equation may be applied to the aircraft (Fig 9.23-1) as follows:

$$y_{\max} = -\frac{F_{m_{\max}} T^3}{48EI} \quad (9.30)$$

where $F_{m_{\max}}$ is the maximum load on the main gear which was obtained earlier in this chapter:

$$F_{m_{\max}} = \frac{B_{n_{\max}}}{B} W \quad (9.8)$$

where B denotes the wheel base and $B_{n_{\max}}$ denotes the maximum distance between aircraft cg and the nose gear in a tricycle configuration. Substituting equation 9.8 into equation 9.30 yields:

$$y_{\max} = -\frac{B_{n_{\max}} WT^3}{48EIB} \quad (9.31)$$

Now we can write wheel track in terms of maximum allowable deflection and other parameters:

$$T = \left[\frac{48EIB y_{\max}}{WB_{n_{\max}}} \right]^{\frac{1}{3}} \quad (9.32)$$

Using this equation, one can determine the maximum limit for the wheel track in terms of aircraft weight, aircraft geometry, and structural coefficients. Since the wheel track is inversely proportional to the aircraft

weight, the critical condition is with maximum take-off weight. This technique can be easily revised for other landing gear configurations.

Example 9.6

An aircraft with a mass of 30,000 kg and wing span of 42 m has a tricycle landing gear configuration. The wheel base is 15 m, and the maximum distance between the aircraft cg and the nose gear is 13 m. The wing is made of aluminum with a modulus elasticity of 70 MPa. Assume that the wing can be modeled with a beam of I-section with a second moment of area of 0.003 m⁴. If the maximum allowable wing deflection is 3 cm, determine the maximum allowable wheel track.

Solution:

$$T = \left[\frac{48EIBy_{\max}}{WBn_{\max}} \right]^{\frac{1}{3}} = \left[\frac{48 \times 70 \times 10^9 \times 0.003 \times 15 \times 0.03}{30000 \times 9.81 \times 13} \right]^{\frac{1}{3}} \Rightarrow T = 10.58 \text{ m} \quad (9.32)$$

No	Aircraft	Type	Take-off mass (kg)	Overall length (m)	Wheel base (m)	Wheel track (m)
1	Airbus A-380	Airliner	590,000	72.73	30.4	14.3
2	Airbus A-300-600	Airliner	170,500	54.08	18.62	9.60
3	Airbus A-319	Airliner	75,500	33.84	11.04	7.59
4	Airbus A-340-500	Airliner	372,000	67.9	27.59	10.69
5	MD-11	Airliner	237,289	61.24	24.61	10.56
6	Boeing B-767-200	Airliner	136,080	48.81	19.69	9.30
7	Boeing B-747-400	Airliner	362,875	70.66	25.6	11
8	Boeing B-737-300	Airliner	56,470	33.40	12.45	5.23
9	Northrop Grumman B-2 Spirit	Bomber	170550	21.03	9.76	12.2
10	Mooney M20J MSE	Touring	1,315	7.52	1.82	2.79
11	Piper PA-44-180 Malibu	Trainer	1,723	8.41	2.56	3.20
12	Beech super king 200	Transport	5,670	13.34	4.56	5.23
13	Beechjet 400A	Trainer	7,303	14.75	5.86	2.84
14	Cessna 208	Light GA	3,629	11.46	3.54	3.56
15	Cessna 650	Business	10,183	16.9	6.5	2.84
16	Gulfstream IV-SP	Transport	33,838	26.92	11.61	4.17
17	Lockheed C-130J Hercules	Tactical Transport	70,305	29.79	12.3	4.43
18	C-17A Globemaster III	Transport	265,352	53.04	20.05	10.27
19	F-15E eagle	Fighter	36,741	19.43	5.42	2.75
20	F/A-18 Hornet	Attack	16,651	17.07	5.42	3.11

Table 9.5. Wheel base and wheel track for several aircraft

9.6. Landing Gear and Aircraft Center of Gravity

An important factor in the landing gear design process is to determine the location of the main gear relative to the aircraft center of gravity. An aircraft has usually two extreme center of gravity (cg) locations:

1. Most forward cg
2. Most aft cg

In an aircraft with a tricycle landing gear, the location of the main gear with respect to the most aft cg is governed by tipback angle requirement. Furthermore, the location of the main gear with respect to the most forward cg is governed by take-off rotation requirement. The tipback angle requirement is described in Section 9.6.1; while the details of the take-off rotation requirements will be presented in Section 9.6.2. For other landing gear configurations, the reader is asked to identify and develop the requirements with respect to cg locations.

On the other hand, in an aircraft with a tail-wheel landing gear, the location of the main gear with respect to the most forward cg is governed by tipback angle requirement. But, the location of the main gear with respect to the most aft cg is governed by take-off rotation requirement. For other configuration, the reader is asked to identify the requirements with respect to cg locations. The tipforward angle requirement is described in Section 9.6.1; while the take-off rotation requirements is briefly presented in Section 9.6.2. For other landing gear configurations, the reader is asked to identify and develop the requirements with respect to cg locations.

The significance of relating the landing gear design with the aircraft center of gravities is to make sure major landing gear variables such as wheel base, wheel track and wheel height are satisfying all requirements. When the above mentioned requirements are satisfied, one or more changes in the design must be applied. In majority of the cases, the designer at this point needs to iterate the landing gear design and revise the values. In rather noticeable cases, the designer is forced to redesign other aircraft components (e.g. wing, tail, and fuselage). Even, in some cases, the designer has to switch to a new aircraft configuration. Thus the satisfaction of these three requirements is very crucial in the entire aircraft design process.

9.6.1. Tipback and Tipforward Angles Requirements

The tipback and tipforward angles requirements are defined to prevent the aircraft from tipping back on its tail or tipping forward on its nose. The tipback angle requirement regulates the distance between aircraft most aft cg and the main gear in a tricycle configuration. On the other hand, the tipforward angle requirement regulates the distance between aircraft most forward cg and the main gear in a tail gear configuration.

In an aircraft with a tricycle landing gear, if during a take-off rotation, the aircraft cg moves aft of the main gear, the aircraft will fall back onto the ground. Similarly, in an aircraft with a tail-wheel landing gear, if during a take-off rotation, the aircraft cg moves forward of the main gear, the aircraft nose will fall forward onto the ground. To prevent such accidents as tipback and tipforward, two requirements are defined. These two requirements are examined in this section. For other landing gear configurations, the fundamentals of these two requirements need to be applied accordingly.

9.6.1.1. Tipback Angles Requirement

The tipback angle is the maximum aircraft nose-up attitude with the tail touching the ground and the strut is fully extended. To prevent a tipback in a tricycle configuration, the tipback angle (α_{tb}) must always be greater than the take-off rotation angle (α_{TO}) (see Fig. 9.24-1).

$$\alpha_{tb} \geq \alpha_{TO} + 5 \text{ deg} \quad (9.33)$$

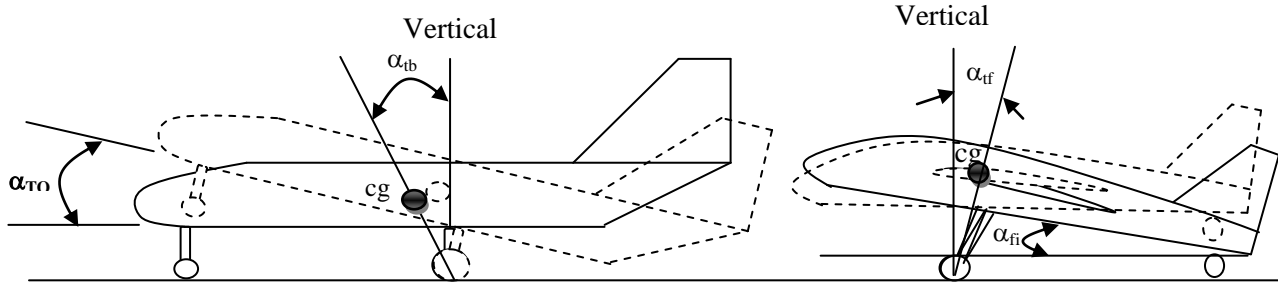

1. Aircraft with tricycle landing gear 2. Aircraft with tail-wheel landing gear
Figure 9.24. Tipback angle, tipforward angle and take-off rotation

In equation 9.33, the angular difference of 5 degrees is selected as a safety assurance to cover uncertainties. The typical take-off rotation angle is about 10-15 degrees, so the tipback angle must be equal or greater than 15-20 degrees. Furthermore, the tipback angle must be less than the angle measured from the vertical (at the main gear location) to the aircraft most aft center of gravity. One of the techniques to increase the tipback angle is to reduce the landing gear height. The second way is to move back the main gear.

9.6.1.2. Tipforward Angles Requirement

For the case of an aircraft with tail-wheel landing gear, the term tipforward angle (α_{tf}) is employed (see Fig. 9.24-2). The tipforward angle is the angle between the vertical and the line passing through the aircraft most forward cg and the contact point between tire and the ground. The tipforward angle must be greater than the fuselage incline angle (α_{fi}). The angle is measured when the aircraft is in the horizontal position.

$$\alpha_{tf} \geq \alpha_{fi} + 5 \text{ deg} \quad (9.34)$$

In equation 9.34, the angular difference of 5 degrees is selected as a safety assurance to cover uncertainties. An aircraft with a tail gear during take-off is normally rotated about its main gear due to a local increase in the tail lift. Thus, if the cg during take-off rotation passes the vertical limit, the nose will fall forward onto the ground. To avoid this accident, the landing gear height (i.e. main gear height) must be increased or its location must be moved forward. As a rule of thumb, the tipforward angle is usually between 12 degrees to 20 degrees.

9.6.2. Take-off Rotation Requirement

For an aircraft with a landing gear configuration which the main gear is behind aircraft cg (e.g. tricycle landing gear), the take-off rotation requirement is defined to regulate the distance between main gear to the most forward cg. Most aircraft, to become airborne, must be rotated about the main gear to achieve the angle of attack required for lift-off. Exceptions to this are aircraft like military bomber B-52. The take-off rotation requirement requires the distance between main gear and the most forward cg be such

that the pitch angular acceleration ($\ddot{\theta}$) is greater than a desired value. In this section, the requirement is mathematically developed and we specifically focus on the relationship with landing gear design.

The angular acceleration about the main gear rotation point, $\ddot{\theta}$ is a function of couple of parameters including horizontal tail area, horizontal tail arm, elevator control power, aircraft weight, rotation speed, and finally the distance between main gear and the aircraft cg. Typical rotational acceleration is given in Table 9.6 for various types of aircraft. The rotation acceleration is the aircraft

acceleration at the time the aircraft begins to rotate about the main gear. This speed must be slightly more than stall speed (V_s). During landing gear design process, it may be assumed that the airplane rotation speed is:

$$V_R = 1.1 V_s - 1.3 V_s \quad (9.35)$$

No	Aircraft type	Take-off pitch angular acceleration; $\ddot{\theta}$ (deg/sec ²)
1	Highly maneuverable (e.g. acrobatic, fighter)	10-20
2	Utility; semi-acrobatic	10-15
3	Normal light General Aviation	8-10
4	Small transport	6-8
5	Large transport	4-6

Table 9.6. Take-off rotational acceleration for various aircraft

In this Section, an analysis of the distance between main gear and the aircraft cg required to generate a given level of pitch angular acceleration about the main gear contact point is presented. Consider the aircraft with a tricycle landing gear in figure 9.25 which is at the onset of a rotation about the main gear in a take-off operation. The figure illustrates all forces and moments contributing to this moment of the take-off. Contributing forces include wing-fuselage lift (L_{wf}), horizontal tail lift (L_h), aircraft drag (D), friction force between tire and the ground (F_f), aircraft weight (W), engine thrust (T), and acceleration force ($m.a$). Please note that latter force ($m.a$) is acting backward due to the Newton's third law as a reaction to the acceleration. Furthermore, the contributing moments are the wing-fuselage aerodynamic pitching moment (M_{owf}) plus the moments of preceding forces about the rotation point. The distance between these forces are measured with respect to both x- reference line (i.e. fuselage nose), and z-reference line (i.e. ground) as shown in figure 9.25.

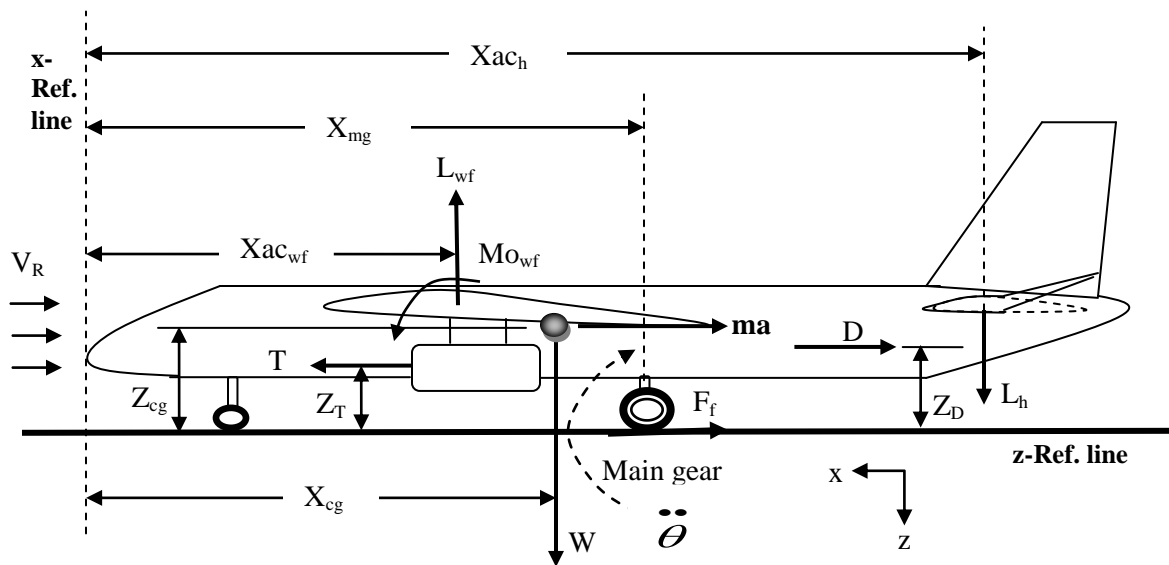

Figure 9.25. Forces and moments during take-off rotation

For a conventional aircraft with tricycle landing gear, the horizontal tail lift is negative during rotation. It is recommended to consider the ground effect on the lift and drag. The friction coefficient, μ , depends on the type of terrain. Table 9.7 introduces the friction coefficients for different terrains.

Type of terrain	Concrete	Asphalt	Hard turf	Short grass	Long grass	Firm dirt
Wheel-ground friction coefficient	0.03-0.04	0.04-0.05	0.05	0.05-0.07	0.07-0.1	0.04-0.06

Table 9.7. Friction coefficient for various runways

There are three governing equations of motion that govern the aircraft equilibrium at the instant of rotation; two force equations and one moment equation:

$$\sum F_x = m \frac{dV}{dt} \Rightarrow T - D - F_f = ma \Rightarrow T - D - \mu N = ma \quad (9.36)$$

$$\sum F_z = 0 \Rightarrow L + N = W \Rightarrow L_{wf} - L_h + N = W \Rightarrow N = W - (L_{wf} - L_h) \quad (9.37)$$

$$\sum M_{cg} = I_{yy_{mg}} \ddot{\theta} \Rightarrow -M_W + M_D - M_T + M_{L_{wf}} + M_{ac_{wf}} + M_{L_h} + M_a = I_{yy_{mg}} \ddot{\theta} \quad (9.38)$$

In equation 9.36, the force N is the normal force on the ground which is obtained from

$$N = W - L_{TO} \quad (9.39)$$

So, the friction force (F_f) is:

$$F_f = \mu N = \mu(W - L_{TO}) \quad (9.40)$$

The aircraft take-off lift is obtained by the following expression:

$$L_{TO} = \frac{1}{2} \rho V_R^2 C_{L_{TO}} S_{ref} \quad (9.41)$$

where the aircraft lift is equal to the sum of wing-fuselage lift (L_{wf}), plus horizontal tail lift (L_h):

$$L_{TO} = L_{wf} + L_h \Rightarrow L_{wf} = L_{TO} - L_h \quad (9.42)$$

where

$$L_h = \frac{1}{2} \rho V_R^2 C_{L_h} S_h \quad (9.43a)$$

$$L_{wf} = \frac{1}{2} \rho V_R^2 C_{L_{wf}} S_{ref} \quad (9.43b)$$

A negative sign for the horizontal tail in equation 9.37 indicates that this force acts downward. This force is generated by upward deflection of elevator. The other aerodynamic forces and pitching moment are obtained from the following expressions:

$$D = \frac{1}{2} \rho V_R^2 C_D S_{ref} \quad (9.44)$$

$$M_{ac_{wf}} = \frac{1}{2} \rho V_R^2 C_{m_{ac_{wf}}} S_{ref} \bar{C} \quad (9.45)$$

where V_R denote the aircraft linear forward speed at the instant or rotation, S_{ref} represents the wing planform area, S_h is the horizontal tail planform area, ρ is the air density, and \bar{C} is the wing mean aerodynamic chord. Furthermore, four coefficients of C_D , $C_{L_{wf}}$, C_{L_h} , and $C_{m_{ac_{wf}}}$ denote drag, wing-fuselage lift, horizontal lift, and wing-fuselage pitching moment coefficients respectively.

In equation 9.38, the clockwise rotation is assumed to be as positive rotation. Thus, the aircraft weight and engine thrust both create negative moments. Recall that the wing-fuselage pitching moment is also inherently negative, so its sign is already included. In equation 9.38, the contributing moments are aircraft weight moment (M_W), aircraft drag moment (M_D), engine thrust moment (M_T), wing-fuselage lift moment ($M_{L_{wf}}$), wing-fuselage aerodynamic pitching moment ($M_{ac_{wf}}$), horizontal tail lift moment (M_{L_h}), and linear acceleration moment (M_a). These moments are obtained as follows:

$$M_W = W(x_{mg} - x_{cg}) \quad (9.46)$$

$$M_D = D(z_D - z_{mg}) \quad (9.47)$$

$$M_T = T(z_T - z_{mg}) \quad (9.48)$$

$$M_{L_{wf}} = L_{wf}(x_{mg} - x_{ac_{wf}}) \quad (9.49)$$

$$M_{L_h} = L_h(x_{ac_h} - x_{mg}) \quad (9.50)$$

$$M_a = ma(z_{cg} - z_{mg}) \quad (9.51)$$

In equations 9.46 through 9.51, the subscript ‘‘mg’’ denotes main gear, since the distances are measured from the main gear. The inclusion of the moment generated by the aircraft acceleration (equation 9.51) is due to the fact that based on the Newton’s third law; any action creates a reaction (ma). This reaction force is producing a moment when its corresponding arm is taken into account. Substituting these moments into equation 9.38 yields:

$$\sum M_{cg} = I_{yy} \ddot{\theta} \Rightarrow -W(x_{mg} - x_{cg}) + D(z_D - z_{mg}) - T(z_T - z_{mg}) + L_{wf}(x_{mg} - x_{ac_{wf}}) + \quad (9.52)$$

$$M_{ac_{wf}} - L_h(x_{ac_h} - x_{mg}) + ma(z_{cg} - z_{mg}) = I_{yy_{mg}} \ddot{\theta}$$

where $I_{yy_{mg}}$ represents the aircraft mass moment of inertia about y-axis at the main gear. Thus, the aircraft mass moment of inertia about cg (y-axis) must be transferred to the main gear contact point ($I_{yy_{mg}}$) by employing the parallel axis theorem:

$$I_{yy_{mg}} = I_{yy_{cg}} + m(d_{cg-mg})^2 \quad (9.53)$$

where d_{cg-mg} is the distance between the aircraft cg to the main gear contact point, and m is the aircraft mass.

Please note that for a tricycle landing gear, the tail lift moment, wing-fuselage moment, drag moment, and acceleration moment are all clockwise, while the weight moment, thrust moment, and wing-fuselage aerodynamic pitching moment are counterclockwise. These directions must be considered when assigning a sign to each one. The equation 9.52 is only a function of one unknown (x_{mg}); the distance between main gear and a reference line; which can be obtained from equations 9.52. The result is as follows:

$$x_{mg} = \frac{I_{yy_{mg}} \ddot{\theta} - D(z_D - z_{mg}) + T(z_T - z_{mg}) - M_{ac_{vf}} - ma(z_{cg} - z_{mg}) - Wx_{cg} + L_{vf}x_{ac_{vf}} + L_hx_{ac_h}}{L_{vf} + L_h - W} \quad (9.54)$$

Then this distance will be used to determine the main gear location with respect to aircraft most forward cg ($x_{mg} - x_{cg}$) in order to satisfy the for take-off rotation requirement. The magnitude of the linear acceleration is determined by employing equation 9.36. It is interesting to note that, this distance ($x_{mg} - x_{cg}$) is the maximum allowable distance for main gear location. You may reduce this distance to account for other design requirements.

Example 9.7

A small subsonic business aircraft (Fig. 9.26) with a take-off mass of 13,000 kg and a wing area of 45 m² has two turbofan engines, each generating 20,000 N of thrust. The overall length of the aircraft is 15 m, it has a tricycle landing gear, and the runway is concrete. Assume that the forward cg is at 20% MAC, and wing-fuselage ac is at 24% MAC. The aircraft is equipped with a single slotted flap which is set to generate extra lift coefficient of 0.6 during take-off. The elevator deflection during take-off rotation is generating tail lift coefficient of -1.1.

Some dimensions of the aircraft are shown in Fig. 9.26, and other characteristics of the aircraft are as follows:

$V_c = 400$ KTAS (at 20,000 ft), $V_s = 80$ KEAS, $C_{D0} = 0.025$, $C_{D0_{TO}} = 0.035$, $I_{yy_{mg}} = 20,000$ kg.m², $AR = 10$, $C_{mo} = -0.04$, $e = 0.92$, $S_h = 9$ m²

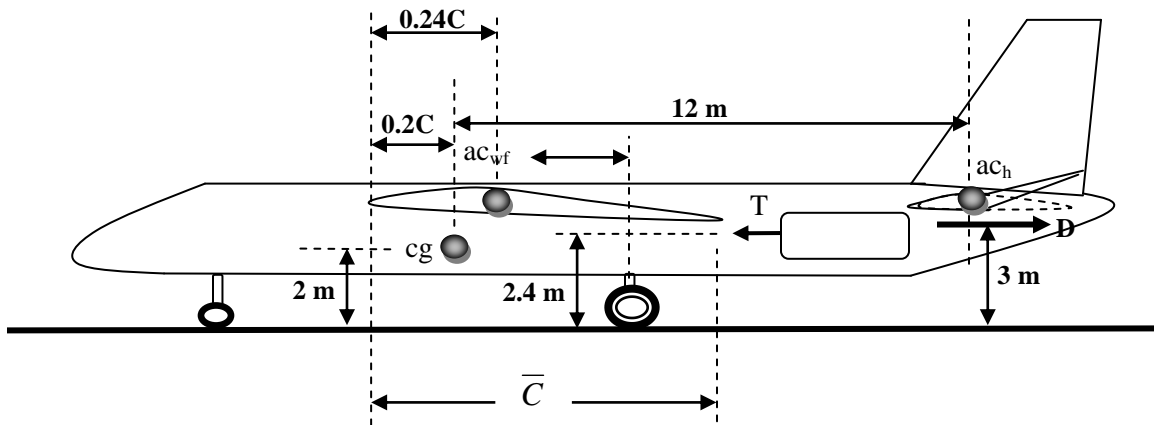

Figure 9.26. Aircraft in Example 9.7

The aircraft is required to rotate about the main gear with an angular acceleration of 7 deg/sec² during the take-off operation at sea level altitude; determine the distance between main wheel to aircraft forward cg.

Solution:

From Fig. 9.26, we can extract the following dimensions:

$$h_{cg} = 2 \text{ m}, h_D = 3 \text{ m}, h_T = 2.4 \text{ m}, l_h = 12 \text{ m}, x_{L_{wf}} = x_{mg} - (0.24 - 0.2)\bar{C}$$

The air density at sea level is 1.225 kg/m^3 , and at 20,000 ft is 0.653 kg/m^3 . To obtain the wing mean aerodynamic chord:

$$b = \sqrt{S \cdot AR} = \sqrt{45 \times 10} = 21.213 \text{ m} \quad (5.19)$$

$$\bar{C} = \frac{S}{b} = \frac{45}{21.213} = 2.121 \text{ m} \quad (5.18)$$

To find aircraft drag:

$$K = \frac{1}{\pi \cdot e \cdot AR} = \frac{1}{3.14 \times 0.92 \times 10} = 0.035 \quad (5.22)$$

$$C_{L_c} = \frac{2W}{\rho V_C^2 S} = \frac{2 \times 13000 \times 9.81}{0.653 \times (400 \times 0.5144)^2 \times 45} = 0.205 \quad (5.1)$$

$$C_{L_{TO}} = C_{L_c} + \Delta C_{L_{flap}} = 0.205 + 0.6 = 0.805 \quad (5.x)$$

$$C_{D_{TO}} = C_{D_{\sigma TO}} + KC_{L_{TO}}^2 = 0.035 + 0.035 \times 0.805^2 = 0.057 \quad (5.x)$$

$$V_R = 1.1V_S = 1.1 \times 80 = 88 \text{ knot} \quad (9.35)$$

$$D_{TO} = \frac{1}{2} \rho V_R^2 S C_{D_{TO}} = \frac{1}{2} \times 1.225 \times (88 \times 0.5144)^2 \times 45 \times 0.057 = 3244.9 \text{ N} \quad (9.44)$$

Other aerodynamic forces and moments:

$$L_{TO} = \frac{1}{2} \rho V_R^2 S_{ref} C_{L_{TO}} = \frac{1}{2} \times 1.225 \times (88 \times 0.5144)^2 \times 45 \times 0.805 = 45490 \text{ N} \quad (9.41)$$

$$L_h = \frac{1}{2} \rho V_R^2 S_h C_{L_h} = \frac{1}{2} \times 1.225 \times (88 \times 0.5144)^2 \times 9 \times (-1.1) = -12433 \text{ N} \quad (9.43a)$$

$$M_{ac_{wf}} = \frac{1}{2} \rho V_R^2 C_{m_{ac_{wf}}} S_{ref} \bar{C} = \frac{1}{2} \times 1.225 \times (88 \times 0.5144)^2 \times 45 \times (-0.04) \times 2.121 = -4795.4 \text{ N} \quad (9.45)$$

$$L_{wf} = L_{TO} - L_h = 45490 - (-12433) = 57923 \text{ N} \quad (9.42)$$

Friction force:

$$F_f = \mu(W - L_{TO}) = 0.02(13000 \times 9.81 - 45490) = 1640 \text{ N} \quad (9.40)$$

Aircraft linear acceleration at the time of take-off rotation

$$a = \frac{T - D - F_R}{m} = \frac{20000 \times 2 - 3244.9 - 1640}{13000} \Rightarrow a = 2.701 \frac{m}{s^2} \quad (9.36)$$

Contributing moments are:

$$M_W = W(x_{mg} - x_{cg}) = W(x_{mg}) \quad (9.46)$$

$$M_D = D(z_D - z_{mg}) = 3244.9 \times 3 = 9734.6 \text{ Nm} \quad (9.47)$$

$$M_T = T(z_T - z_{mg}) = 20000 \times 2 \times 2.4 = 96000 \text{ Nm} \quad (9.48)$$

$$M_{L_{vf}} = L_{vf}(x_{mg} - x_{ac_{vf_to_cg}}) = 57923 \times (x_{mg} - 0.04 \times 2.121) \quad (9.49)$$

$$M_{L_h} = L_h(x_{ac_h} - x_{mg}) = -12433.3 \times (12 - x_{mg}) \quad (9.50)$$

$$M_a = ma(z_{cg} - z_{mg}) = 13000 \times 2.701 \times 2 = 70230.4 \text{ Nm} \quad (9.51)$$

Please note that in this example, the x reference line is assumed to be the aircraft cg; thus $x_{cg} = 0$. Furthermore, for all moment arms, the absolute value is utilized. Now all moments are substituted into the equation 9.54:

$$x_{mg} = \frac{I_{yy_{mg}} \ddot{\theta} - D(z_D - z_{mg}) + T(z_T - z_{mg}) - M_{ac_{vf}} - ma(z_{cg} - z_{mg}) - Wx_{cg} + L_{vf}x_{ac_{vf}} + L_hx_{ac_h}}{L_{vf} + L_h - W} \quad (9.54)$$

$$x_{mg} = \frac{20000 \times \frac{7}{57.3} - 9734.6 + 96000 - (-4795.4) - 70230.4 + (57923 \times 0.04 \times 2.121) + (-12433.3 \times 12)}{57923 - 12433.3 - (13000 \times 9.81)} \quad (9.54)$$

which yields:

$$x_{mg} = 1.476 \text{ m}$$

This distance indicates that the aircraft has the following tipback angle:

$$\alpha_f = \tan^{-1}\left(\frac{x_{mg}}{h_{cg}}\right) = \tan^{-1}\left(\frac{1.476}{2}\right) = 0.636 \Rightarrow \alpha_f = 36.4 \text{ deg} \quad (9.x)$$

9.7. Landing Gear Mechanical Subsystems/Parameters

The scope of this book concerns the aeronautical engineering aspects of landing gear design which contain parameters such as landing gear configuration, fixed or retractable, landing gear height, wheel base, wheel track, and the distance from main wheel to aircraft center of gravity. The Mechanical engineering aspects/subsystems of landing gear design were left to other references which discuss those items in more details. In another word, those parameters would often be asked from mechanical engineers to deal with them. The design of the landing gear subsystems/parameters such as retraction system, steering subsystem, shock absorber, tire sizing, braking subsystem, and strut sizing are reviewed in brief in this section.

9.7.1. Tire Sizing

Technically, the term “wheel” refers to a circular metal/plastic object around which the rubber “tire” is mounted. The brake system is mounted inside the wheel to slow the aircraft during landing. However, in majority of cases, the entire wheel, tire, and brake system is also referred to as the wheel. The fundamental materials of modern tires are synthetic or natural rubber, fabric and wire, along with other compound chemicals. Today, the vast majority of tires is generally pneumatic inflatable and includes a doughnut-shaped body of cords and wires encased in rubber. So they consist of a tread and a body (Figure 9.27). Tires perform four important functions with the assistance of the air contained within them:

1. Tires support the aircraft structure off the ground.
2. They help absorb shocks from the runway surface.
3. They help transmit acceleration and braking forces to the runway surface.
4. They help change and maintain the direction of motion.

A tire carries the load almost entirely by its internal pressure. Tire sizing includes the calculations of the tire outer diameter (D_t), and tire width (W_t); and then, select the closest tire in the market from a manufacturer’s catalog (e.g. Ref. 7 and Ref. 8). Tire selection should be based on the smallest diameter which rated to carry the desired dynamic and static loads.

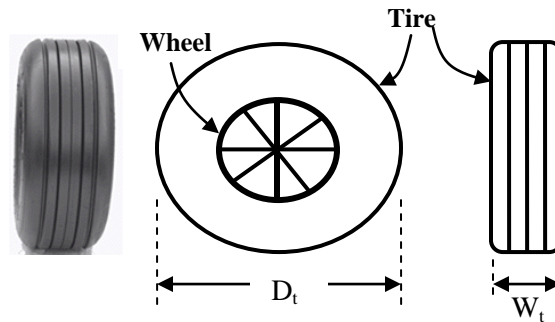

Figure 9.27. Tire geometry

As a guideline, the following is the information about tires of a civil transport, a military fighter, and a GA aircraft .The transport aircraft Boeing 777-200 is employing (Ref. 5) Goodyear main tires H49×19-22, and Michelin radial nose wheel tires 44×18-18. The fighter aircraft McDonnell Douglas F-15 Eagle is utilizing (Ref. 5) Bendix wheels and Michelin AIR X with nose wheel tires size 22×7.75-9, and main wheel tires size 36×11-18 where tire pressure is 305 psi. The main wheel tire of business jet Cessna 650 Citation VII (Ref. 5) is of size 22×5.75 (pressure of 168 psi), while the nose wheel tire size is 188×4.4 (140 psi).

Generally speaking, for a tricycle configuration, nose tires may be assumed to be about 50 -100% the size of the main tires. For quadricycle and bicycle configurations, the front tires are often the same size as the main tires.

9.7.2. Shock Absorber

The landing gear must be able to absorb the shocks exerted on the structure during the landing operation (mainly at touch-down phase). Some light, ultra-light, small and homebuilt, most helicopters, and plus sailplanes are built with rigid axles or solid spring, relying solely on the tires and solid springs for absorbing shocks. Although the tires themselves provide some shock-absorbing abilities by deflection, but for medium/large aircraft, the requirements for absorbing shock are higher than what tires are offering. The solid spring (Fig. 9.28-1), which tends to be fairly simple in design, is employed in many GA light aircraft (e.g. Cessna 172, Cessna Caravan I, Beech 77 Skipper, AkroTech Aviation Giles G-200). However, almost all modern transport aircraft and military fighters (e.g. Boeing 737, Boeing 767, Airbus 320, F/A-18, C-130 Hercules, and F-16) are equipped with oleo-pneumatic shock absorbers or “oleo” (Fig. 9.28-2). The oleo combines a mechanical coil spring (in air) with a hydraulic damper (piston-oil-cylinder-orifice).

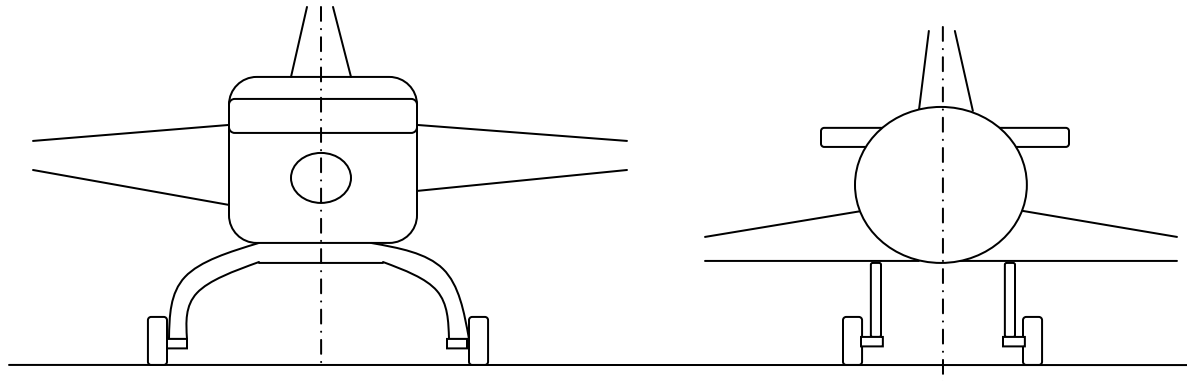

1. Solid spring

2. Oleo shock strut

Figure 9.28. Landing gear with shock absorber

In general, if the landing gear is selected to be fixed, a solid spring (i.e. bar), a rigid axle, or a rubber bungee would be suitable options. However, if the landing gear is decided to be retracted, the hydraulic shock absorber (preferably oleo-pneumatic shock strut) is an appropriate option. In terms of cost, an oleo shock absorber is much more expensive than a solid spring. Furthermore, the maintenance of an oleo shock absorber is very labor extensive than a solid spring.

In both cases, the deflection of the solid spring or the oleo will change the length of the strut; the parameter which must be taken into account during the landing gear design process. The desired deflection of the shock absorbing system (i.e. stroke) is a function of aircraft landing speed during touch-down, as well as the damping requirements. A smoother landing requires a longer deflection, which in turn applies less “g” on the structure. The total aircraft energy that must be absorbed during touch-down is a kinetic energy which is derived by the aircraft mass as well as aircraft vertical velocity at the instance of touch-down.

When a solid spring is chosen, the main parameter for the design is the geometry and the cross section of the beam. For more information on the solid spring (i.e. beam) design, the reader is referred to references such as Ref. 4. In case that a hydraulic shock absorber is selected for the landing gear, the typical parameters which must be determined include stroke, orifice, outer and inner diameter, and internal spring sizing. References such as Ref. 9 may be consulted for more information.

9.7.3. Strut Sizing

The wheel strut must be sized, in that the cross section and its area need to be determined. The cross section is primarily a function of aircraft mass, load per wheel, landing gear height, safety factor, strut deflection, strut material, and “g” load during touch-down. There are various mechanical engineering references in the literature such as Ref. 4 that the reader is referred to for more details. Two typical strut cross sections are circular and rectangular. If the landing gear is a non-retractable one, it is recommended to use fairing for struts; such that the cross sectional area resembles a symmetric airfoil. This technique will considerably reduce the strut drag.

9.7.4. Steering Subsystem

An aircraft must be able to taxi on the ground in an airport including turning maneuver. For instance, the minimum ground turning radius of the transport aircraft Boeing 757 is 71 ft at nose wheel, 98 ft at wingtip. For the purpose of the ground steering, a nose wheel, the main wheel, or tail wheel must be capable of being turned (castored). For an aircraft with tricycle landing gear, a steerable nose wheel is usually employed, while for an aircraft with tail wheel landing gear, a steerable tail wheel is often utilized. However, the steering capability may be augmented by the use of differential braking on the

main gear. For a multi-engine aircraft, the use of differential thrust is another technique to steer the aircraft. The steering mechanism is frequently connected to the rudder pedal, providing a direct control of the turning angle. Most modern and large aircraft are equipped with hydraulic type steering systems.

A castoring wheel may cause wheel shimmy, a rapid side-to-side motion of the wheel which can break the landing gear. A typical solution to wheel shimmy is to employ the rake angle (Fig. 9.29) and trail (i.e. offset), or frictional shimmy damper. If the castoring wheel is free to swivel; as is the case for most tail wheels; shimmy could be prevented by utilizing a small angle of rake, as well as an appropriate trail.

The win-turbofan business transport Gulfstream IV-SP employs the steerable nose wheel forward. The Learjet 60 nose wheel is equipped with a twin dual-chine tire, size 18x4.4, with steer-by-wire. The Boeing 777 is employing a twin-wheel steerable nose gear, two main legs carrying six-wheel bogies with steering rear axles automatically engaged by nose gear steering angle. The Beech Super King Air 200 has a single wheel on steerable nose unit.

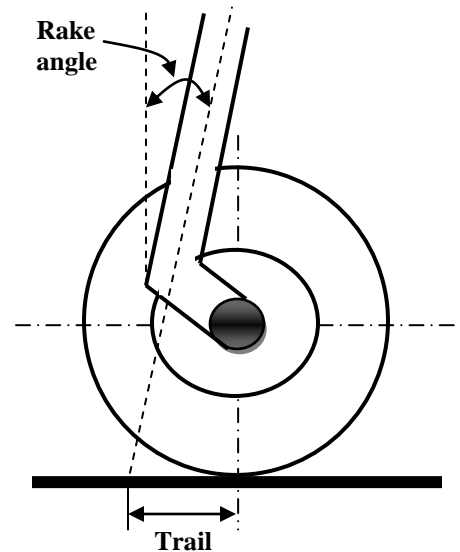

Figure 9.29. Steering wheel geometry

9.7.5. Landing Gear Retraction system

One of the very last landing gear subsystems which must be designed in a retractable landing gear is the retraction subsystem. At this point, the geometry of the landing gear plus the home for the retraction (Fig. 9.11) must be known. The retraction subsystem is another mechanical engineering topic that is covered in brief in this section. Ref. 10 and 11 contain basic principles and comprehensive introduction to modern mechanism design with a focus on theoretical foundations.

Landing gear retraction mechanism typically includes a couple of mechanical members and/or piston-cylinder. The direction of retraction (inward, outward, forward, and backward) is another decision which must be made prior to considering more details. The criteria for the selection of type of landing gear retraction mechanism include mechanism weight, volume, cost, maintenance, landing gear-aerostructure integration, and power transmission system. There are variety of design options; two of which convenient retraction systems are hydraulic and mechanical linkage. In general, a hydraulic system is more expensive and heavier than a mechanical linkage.

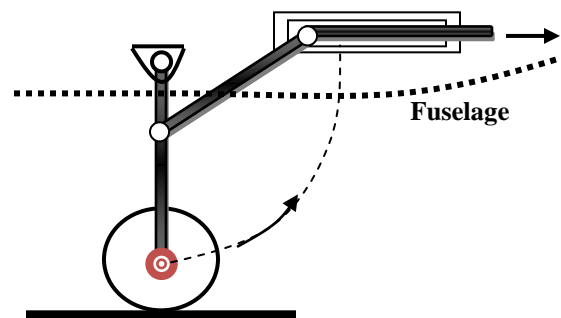

Figure 9.30. Landing gear retraction subsystem

An example of a retraction system is illustrated in Figure 9.30. The following is a couple of real world applications. In commuter aircraft Fairchild SA227, all wheels retract forward, but main gear into engine nacelles and nose wheel into fuselage. In Gulfstream IV-SP main wheels retract inward, while in Learjet 60 main legs retract inward, but nose leg forward. In the light transport aircraft Beech Super King Air 200 hydraulically retractable tricycle landing gear, main unit retract forward, nose wheel rearward.

And finally, in fighters' world; in the F-15 Eagle all units retract forward, while in the F/A-18 Hornet nose unit retracts forward, but main wheel rearward.

9.8. Landing Gear Design Steps

In Sections 9.1 through 9.7, landing gear function, configurations, objectives, alternatives, design criteria, parameters, governing rules and equations, formulation, design requirements, as well as how to approach the primary aero-related parameters have been presented in details. Furthermore, Figure 9.2 illustrates the design flow chart of the landing gear. In this section, landing gear design procedures in terms of design steps are introduced. It must be noted that there is no unique solution to satisfy the customer requirements in designing a landing gear. Several landing gear designs may satisfy the requirements, but each will have a unique advantages and disadvantages.

In order to formulate the design requirements, the designer is encouraged to develop several equations and relations based on the numerical requirements and solve them simultaneously. For instance, for each angle requirement, a trigonometric or the Pythagorean equation may be built for each triangle. In this technique, a computer program would allow a faster and more accurate design. Based on the systems engineering approach, the landing gear detail design begins with identifying and defining design requirements and ends with optimization. The following is the landing gear design steps for a land-based aircraft:

1. Identify and list the landing gear design requirements
2. Select landing gear configuration (e.g. tricycle, tail gear, bicycle, quadric-cycle, multi bogey)
3. Select fixed, or retractable, or partially retractable
4. If fixed, select faired or un-faired
5. Determine aircraft forward and aft center of gravity (assume no landing gear at this moment)
6. Calculate landing gear height, based on ground clearance requirements
7. Determine the distance between main gear and aircraft most forward center of gravity
8. Determine the distance between main gear and aft center of gravity
9. Check tip-back (or tip-forward if tail gear) requirement.
10. Check the take-off rotation clearance requirement
11. Calculate wheel base
12. Determine wheel track (distance between left and right wheels of main gear) in lateral axis
13. Determine landing gear attachments
14. If retractable, determine where the landing gear is going to be retracted (e.g. inside wing, inside fuselage)
15. Determine aircraft forward and aft center of gravity when the landing gear weight is added to the aircraft weight
16. Check overturn angle requirement
17. Investigate structural integrity
18. Investigate aircraft ground clearance requirement
19. Investigate aircraft ground stability
20. Investigate aircraft ground controllability
21. Check other design requirements (e.g. cost, maintainability, and weight)
22. If any of the design requirements is not satisfied, return to the relevant design step and recalculate the corresponding parameter
23. If any landing gear parameters is changed, the entire landing gear needs to be revisited and revised
24. Determine load on each gear

25. Size wheels and tires
26. Design struts
27. Design shock absorber
28. Design gear retracting mechanism
29. Optimize
30. Draw the final design for the landing gear

For other aircraft configurations (e.g. sea-plane) or other landing gear configurations (e.g. bicycle), the reader needs to revise the above-mentioned steps, and establish a revised design procedure.

9.9. Landing Gear Design Example

In this section, a major chapter example is presented to design a landing gear for a transport aircraft. In order to avoid the lengthening of the chapter, it only covers the major design parameters.

Example 9.8

Problem Statement: Design a landing gear for the following subsonic civil transport aircraft to carry 18 passengers. The aircraft has two turboprop engines, and is equipped with a split flap which is deflected 30 degrees during the take-off operation on a concrete runway. Assume that the aircraft forward cg is at 18% MAC, aft cg is at 30% of MAC, and wing-fuselage aerodynamic center is located at 22% MAC. The distance between horizontal tail aerodynamic center to the wing-fuselage aerodynamic center is 13 m.

$m_{TO} = 18,000$ kg, $D_{fmax} = 2.4$ m, $V_{max} = 370$ KTAS (at 27,000 ft), $V_s = 85$ KEAS, $D_{prop} = 3.8$ m, $C_{D_{o_clean}} = 0.02$, $C_{D_{o_TO}} = 0.03$, $I_{yy} = 23,000$ kg.m², $P_{max} = 8,000$ hp, $C_{mo} = -0.03$, $\eta_{P_TO} = 0.5$, $\alpha_{TO} = 14$ deg

Wing: airfoil: $S = 60$ m², NACA 64₁-112, $AR = 12$, $e = 0.9$, $\Delta C_{L_{flap}} = 0.9$, $\lambda = 1$

Horizontal tail: $S_h = 14$ m², NACA 0009, $AR_t = 5$, $C_{Lh_TO} = -0.8$

The aircraft configuration and other geometry variables are illustrated in Figure 9.31. The following parameters must be determined: landing gear configuration; fixed or retractable; height; wheel track; wheel base; and the distance between main wheel to aircraft cg.

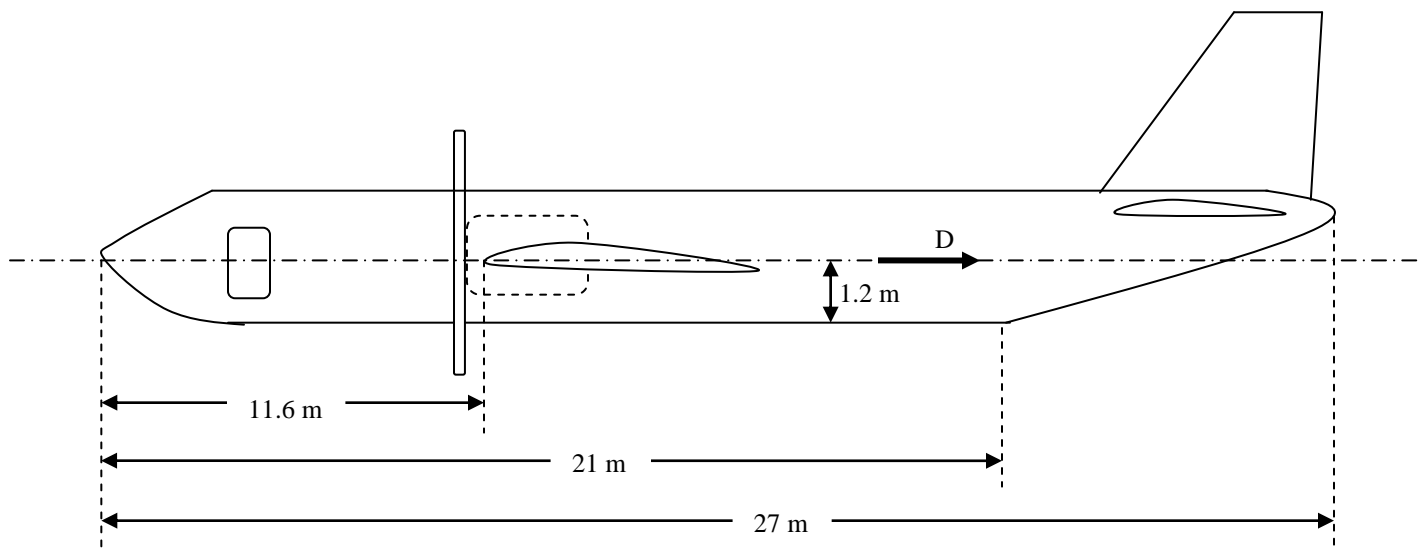

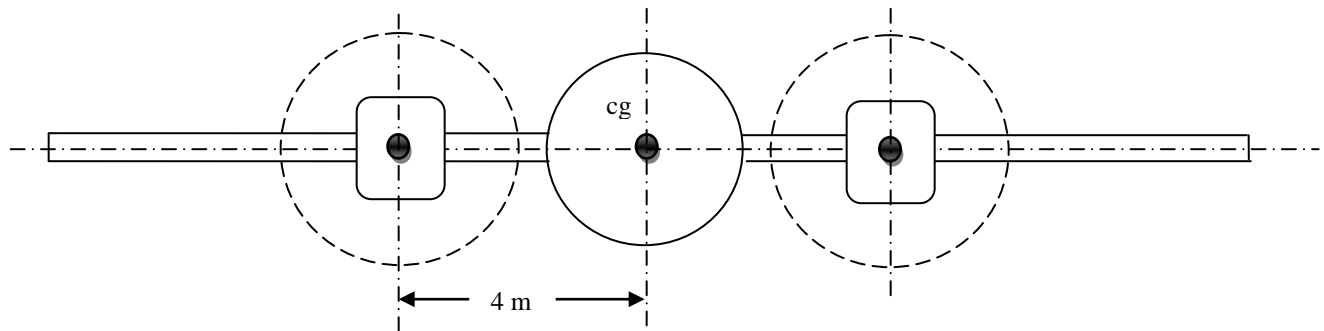

Figure 9.31. Aircraft in Example 9.8

Solution:

Step 1. Landing gear design requirements

The following design requirements are identified to be satisfied: ground clearance requirement, tip-back (or tip-forward angle if tail gear) angle requirement, take-off rotation requirement, overturn angle requirement, structural integrity, aircraft ground stability, aircraft ground controllability, low cost, maintainable, and manufacturable.

Step 2. Landing gear configuration

This is a transport aircraft, and the passenger's comfort is an important requirement. So, the tail gear, bicycle, single main configurations would not satisfy this requirement. Three viable configurations are: 1. tricycle or nose-gear, 2. quadricycle, and 3. multi-bogey. Since the aircraft weight is not very high, both quadricycle, and multi-bogey configurations are set aside due to their cost and weight. Therefore the best landing gear configuration for this aircraft is Nose gear or tricycle. An attractive feature for this configuration is that the aircraft will be horizontal at the ground. The passengers do not have to climb during boarding period. The nose gear also decreases the take-off run, and at the same time, the aircraft will take-off sooner.

Step 3. Fixed or Retractable

The aircraft must compete with other transport aircraft in the market, and it must have a fairly high performance, so a retractable landing gear is the best option. The cost of this configuration covered by the customers (passengers). Then, this will reduce the aircraft drag during flight and therefore the aircraft will feature a higher performance. The higher landing gear weight due to retraction system will be paid off compared with the other advantages of a retractable landing gear.

Step 4. Landing gear height

Based on figure 9.31, the lowest point of the aircraft is the propeller tip. There must be a reasonable clearance between the prop and the ground. Due to the fact that the aircraft engine is turboprop, and for the sake of passengers' safety considerations, a 1.2 m ground clearance for the propeller is considered needed. This distance may be revised in the later phases of design. (i.e. $\Delta H_{\text{clear}} = 1.2 \text{ m}$). Hence, the distance between aircraft center of gravity and the ground would be:

$$H_{cg} = \Delta H_{clear} + \frac{D_{prop}}{2} = 1.2 + \frac{3.8}{2} = 3.1 \text{ m}$$

This clearance is shown in Fig. 9.32. Please note that as fig. 9.31 illustrates, the aircraft cg is at the same height as the wing mid-plane. The landing gear height is a function of its attachment location. The nose gear will be naturally attached to the fuselage. But, the main gear attachment tends to have two main alternatives: 1. Attach to the fuselage, 2. Attach to the wing. As soon the wheel track is determined, we are able to decide about landing gear attachment; and then the landing gear height may be determined.

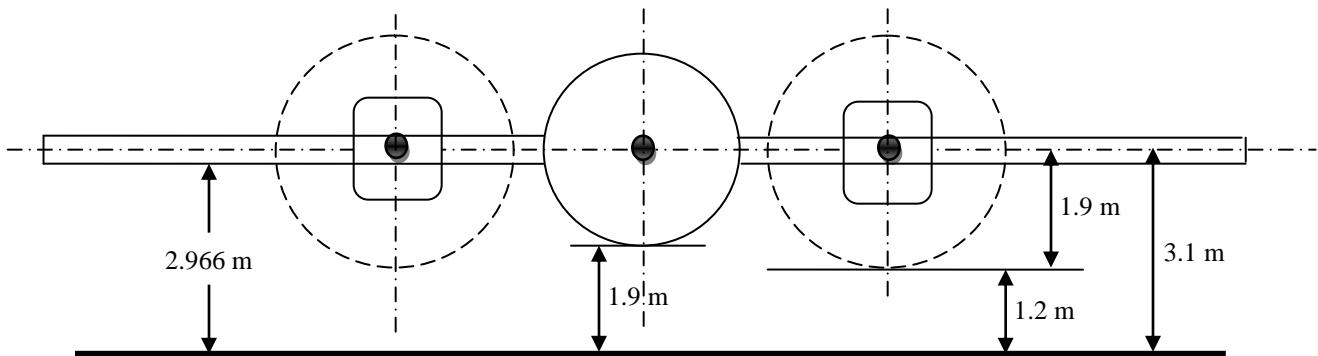

Figure 9.32. Prop clearance

Case 1. Attach main gear to the fuselage

In this case, the landing gear height will be:

$$H_{LG} = H_{cg} - \frac{D_{fuse}}{2} = 3.1 - \frac{2.4}{2} = 1.9 \text{ m}$$

Case 2. Attach main gear to the wing

Wing mean aerodynamic cord is:

$$b = \sqrt{S \cdot AR} = \sqrt{60 \times 12} = 26.833 \text{ m} \quad (5.19)$$

$$\bar{C} = \frac{S}{b} = \frac{60}{26.833} = 2.236 \text{ m} \quad (5.18)$$

The wing airfoil is NACA 64₁-112, so the wing thick-to-chord ratio is 12 percent. Thus the wing thickness is:

$$t_w = \left(\frac{t}{C} \right)_{\max} \bar{C} = 0.12 \times 2.236 = 0.268 \text{ m}$$

In this case, the landing gear height will be:

$$H_{LG} = H_{cg} - \frac{t_w}{2} = 3.1 - \frac{0.268}{2} = 2.966 \text{ m}$$

These two landing gear heights are shown in figure 9.32. When wheel track and wheel base are determined, the main gear attachment will be finalized. Furthermore, in the later steps, other landing gear requirements will be checked to make sure this clearance does not violate any other design requirements.

Step 5. The distance between main gear to the aircraft forward cg

Now we determine the location of main landing gear. Take-off rotation requirement will be employed to obtain this distance. The aircraft is required to be able to rotate during transition segment of the take-off operation with the amount of 9 deg/s^2 . This requirement must be examined for the aircraft critical cg location which is the most forward cg.

Since the aircraft forward cg is at 18% MAC, and the wing-fuselage aerodynamic center is located at 22% MAC, we can write the following relationship for the wing-fuselage lift moment arm:

$$x_{L_{w/f}} = x_{mg} - (\bar{X}_{ac} - \bar{X}_{cg_{fwd}}) \bar{C} = x_{mg} - (0.22 - 0.18) \times 2.236 = x_{mg} - 0.089$$

Furthermore, the distance between horizontal tail aerodynamic center to the wing-fuselage aerodynamic center is 12 m, hence the tail moment arm would be:

$$x_h = x_{ac_h} - x_{mg} = l_h + (\bar{X}_{ac} - \bar{X}_{cg_{fwd}}) \bar{C} - x_{mg} = 13 + (0.22 - 0.18) \times 2.236 - x_{mg} = 13.089 - x_{mg}$$

where x_{mg} is measured from main gear to the forward cg in meters.

From Fig. 9.31 and 9.32, we can extract the following dimensions: $h_D = H_{cg} = h_T = 3.1 \text{ m}$

The air density at sea level is 1.225 kg/m^3 , and at 27,000 ft is 0.512 kg/m^3 . To obtain the wing mean aerodynamic chord:

To find aircraft drag:

$$K = \frac{1}{\pi e AR} = \frac{1}{3.14 \times 0.9 \times 12} = 0.029 \quad (5.22)$$

$$C_{L_c} = \frac{2W}{\rho V_C^2 S} = \frac{2 \times 18000 \times 9.81}{0.512 \times (370 \times 0.5144)^2 \times 60} = 0.317 \quad (5.1)$$

$$C_{L_{TO}} = C_{L_c} + \Delta C_{L_{flap}} = 0.317 + 0.9 = 1.217 \quad (5.x)$$

$$C_{D_{TO}} = C_{D_{TO}} + KC_{L_{TO}}^2 = 0.03 + 0.029 \times 1.217^2 = 0.074 \quad (5.x)$$

$$V_R = 1.1V_S = 1.1 \times 85 = 93.5 \text{ knot} = 48.1 \frac{m}{sec} \quad (9.35)$$

$$D_{TO} = \frac{1}{2} \rho V_R^2 S C_{D_{TO}} = \frac{1}{2} \times 1.225 \times (48.1)^2 \times 60 \times 0.074 = 6267.4 \text{ N} \quad (9.44)$$

Other aerodynamic forces and moments:

$$L_{TO} = \frac{1}{2} \rho V_R^2 S_{ref} C_{L_{TO}} = \frac{1}{2} \times 1.225 \times (48.1)^2 \times 60 \times 1.217 = 103554.6 \text{ N} \quad (9.41)$$

$$L_h = \frac{1}{2} \rho V_R^2 S_h C_{L_h} = \frac{1}{2} \times 1.225 \times (48.1)^2 \times 14 \times (-0.8) = -15879 \text{ N} \quad (9.43)$$

$$M_{ac_{wf}} = \frac{1}{2} \rho V_R^2 C_{m_{ac_{wf}}} S_{ref} \bar{C} = \frac{1}{2} \times 1.225 \times (48.1)^2 \times 60 \times (-0.03) \times 2.236 = -5706 \text{ N} \quad (9.45)$$

$$L_{wf} = L_{TO} - L_h = 103554.6 - (-15879) = 119434 \text{ N} \quad (9.42)$$

Friction force:

$$F_f = \mu(W - L_{TO}) = 0.04(18000 \times 9.81 - 103554.6) = 2918.6 \text{ N} \quad (9.40)$$

The engines total power is 8,000 hp which is equivalent to 5,965,599 Watt. The engine thrust at the instance of rotation is:

$$T = \frac{P \eta_P}{V_R} = \frac{5,965,599 \times 0.5}{48.1} \Rightarrow T = 62011.7 \text{ N} \quad (8.x)$$

Aircraft linear acceleration at the time of take-off rotation

$$a = \frac{T - D - F_R}{m} = \frac{62011.7 - 6267.4 - 2918.6}{18000} \Rightarrow a = 2.935 \frac{m}{s^2} \quad (9.36)$$

Contributing moments:

$$M_W = W(x_{mg} - x_{cg}) = 18000 \times 9.81(x_{mg}) \quad (9.46)$$

$$M_D = D(z_D - z_{mg}) = 6267.4 \times 3.1 = 19429 \text{ Nm} \quad (9.47)$$

$$M_T = T(z_T - z_{mg}) = 62011.7 \times 3.1 = 192,236.4 \text{ Nm} \quad (9.48)$$

$$M_{L_{wf}} = L_{wf}(x_{mg} - x_{ac_{wf_to_cg}}) = 119,433.7 \times (x_{mg} - 0.089) \quad (9.49)$$

$$M_{L_h} = L_h(x_{ac_h} - x_{mg}) = -15879 \times (13.089 - x_{mg}) \quad (9.50)$$

$$M_a = ma(z_{cg} - z_{mg}) = 18000 \times 2.935 \times 3.1 = 163,760 \text{ Nm} \quad (9.51)$$

where, for the sake of simplicity, the x-reference line is considered to be the aircraft forward cg. Now all moments are substituted into the equation 9.54:

$$x_{mg} = \frac{I_{yy_{mg}} \ddot{\theta} - D(z_D - z_{mg}) + T(z_T - z_{mg}) - M_{ac_{wf}} - ma(z_{cg} - z_{mg}) - Wx_{cg} + L_{wf}x_{ac_{wf}} + L_hx_{ac_h}}{L_{wf} + L_h - W} \quad (9.54)$$

By substituting moments and forces, we have:

$$x_{mg} = \frac{23000 \times \frac{9}{57.3} - 19429 + 192,236.4 - (-5706.4) - 163,760 + 0 + (119,433.7 \times 0.089) + (-15879 \times 13)}{119,433.7 - 15879 - (18000 \times 9.81)} \quad (9.54)$$

The solution is:

$$x_{mg} = 2.431 \text{ m}$$

So far, the fact that, the given mass moment of inertia is about aircraft cg, was ignored. Hence, the calculation must be repeated with the revised equation to include the parallel axis theorem. Thus, the aircraft mass moment of inertia about cg (y-axis) must be transferred to the main gear contact point ($I_{yy_{mg}}$) by employing the parallel axis theorem(Equ 9.53):

$$I_{yy_{mg}} = I_{yy_{cg}} + m \left(\sqrt{x_{mg}^2 + h_{cg}^2} \right)^2 = I_{yy_{cg}} + m \left(x_{mg}^2 + h_{cg}^2 \right) \quad (\text{Equ 9.53a})$$

where x_{mg} and h_{cg} are shown in Fig 9.33.

Now, The $I_{yy_{mg}}$ from equation 9.53a is inserted into equation 9.54. The result would be a nonlinear equation with only one unknown parameter (x_{mg}) as follows:

$$x_{mg} = \frac{\left(I_{yy_{cg}} + m \left(x_{mg}^2 + h_{cg}^2 \right) \right) \ddot{\theta} - D(z_D - z_{mg}) + T(z_T - z_{mg}) - M_{ac_{wf}} - ma(z_{cg} - z_{mg}) + L_{wf} x_{ac_{wf}} + L_h x_{ac_h}}{L_{wf} + L_h - W} \quad (9.54a)$$

The solution of this revised equation would be:

$$x_{mg} = 1.916 \text{ m}$$

Step 6. Check tip-back requirement.

In order to check the tipback angel, we have to obtain the distance between aft cg and the main gear. Based on the problem statement, the forward cg is located at 18%MAC, while the aft cg is at 0.3C. Thus, the distance between aircraft aft cg and forward cg is:

$$\Delta x_{cg} = x_{cg_{for}} - x_{cg_{aft}} = (0.30 - 0.18) \bar{C} = 0.12 \times 2.236 = 0.268 \text{ m} \quad (9.x)$$

So the distance between main gear and aft cg is:

$$x_{mg_{aft}} = x_{mg} - \Delta x_{cg} = 1.916 - 0.268 = 1.648 \text{ m} \quad (9.x)$$

This distance indicates that the aircraft has the following tipback angle:

$$\alpha_{tf} = \tan^{-1} \left(\frac{x_{mg}}{h_{cg}} \right) = \tan^{-1} \left(\frac{1.648}{3.1} \right) = 0.489 \text{ rad} \Rightarrow \alpha_{tf} = 28 \text{ deg} \quad (9.x)$$

This tipback angel is greater than aircraft take-off rotation angel (14 deg).

$$28 > 14 + 5 \quad (9.33)$$

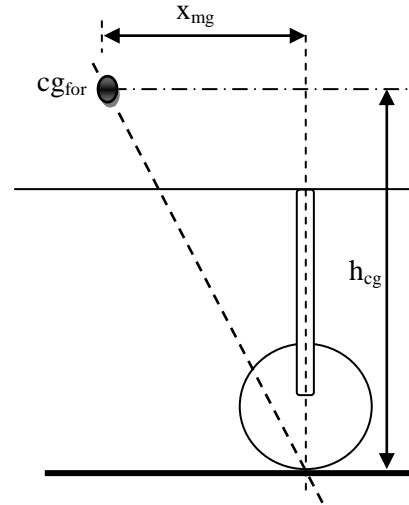

Figure 9.33. Main gear and forward cg

Therefore the distance between main gear and aft cg satisfies the tipback angel requirement. This x_{mg} is the distance between main gear and the aircraft forward cg just to satisfy take-off rotation requirement as well as tipback angel requirement. In the upcoming steps, this value must be examined again to ensure it meets the other design requirements.

Step 7. Check the take-off rotation clearance requirement

The take-off rotation ground clearance requirement to prevent a fuselage hit is as follows:

$$\alpha_C \geq \alpha_{TO} \quad (9.2)$$

In order to determine the clearance angle (α_C), two distances should be obtained: 1. height between lowest point of the fuselage to the ground, 2. distance between the main gear to the fuselage upsweep point. Figure 9.32 illustrates that the fuselage height (H_f) is 1.9 m. On the other hand, from figure 9.31, the length between nose and the fuselage upsweep point is 21 m; and the distance between wing leading edge and the fuselage nose is 11.6 m. Thus, the distance between fuselage upsweep point and the wing leading edge is

$$21 \text{ m} - 11.6 \text{ m} = 9.4 \text{ m}$$

Furthermore, the distance main gear and the wing leading edge is:

$$X_{mg-LE} = x_{mg_{for}} + 0.18\bar{C} = 1.916 + (0.18 \times 2.236) = 2.319 \text{ m} \quad (x)$$

Thus, the distance between the main gear to the fuselage upsweep point (figure 9.34) is:

$$9.4 - 2.319 = 7.081 \text{ m}$$

Therefore the clearance angle is:

$$\alpha_C = \tan^{-1}\left(\frac{H_f}{AB}\right) = \tan^{-1}\left(\frac{1.9}{7.081}\right) = 0.262 \text{ rad} = 15.02 \text{ deg} \quad (9.3)$$

Since the clearance angle (α_C ; 15 deg) is greater than the aircraft rotation angle (α_{TO} ; 12 deg), the fuselage will not hit the ground during take-off operation.

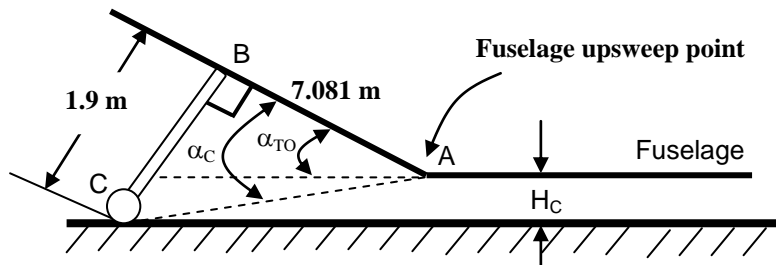

Figure 9.34. Examination of rear fuselage clearance during take-off rotation

Step 8. Wheel base

Due to the ground controllability requirement, the nose gear must not carry less than about 5 percent of the total load and also must not carry more than about 20 percent of the total load (e.g. aircraft weight).

Thus, main gear carries about 80% to 95% of the aircraft load. To meet this requirement, it is decided that the nose gear would carry 15% of the total load and the main gear carries 90% of the total load. The wheel base is determined using equation 9.6:

$$F_n = \frac{B_m}{B} W \quad (9.6)$$

where F_n is selected to be 10% of the total weight, so:

$$B = \frac{B_m}{F_n} W = \frac{B_m}{0.15W} W = \frac{B_m}{0.15} = 6.667 B_m \quad (9.6)$$

where B_m is obtained previously as 1.916 m. Thus, the wheel base (B) is:

$$B = 6.667 \times 1.916 = 12.775 \text{ m}$$

When the cg is at aft location, the nose wheel will carry less than 15 percent of the aircraft weight. This value for wheel base could be revise later for optimization when examining other requirements.

Step 9. Wheel track

Three main design requirements which drive the wheel track (T) are: 1. Ground lateral control, 2. Ground lateral stability, and 3. Structural integrity. The overturn angle is the angle which is critical to the aircraft overturn. There are two overturn angles (Fig. 9.19); in that the smaller one is considered in this technique.

The minimum allowable value for the wheel track must satisfy the overturn angle requirements (Section 9.5.3.1). The maximum allowable value for the wheel track must satisfy the structural integrity requirements (Section 9.5.3.2).

In the first place, to determine the wheel track, we use the criterion of overturning prevention. The lateral distance between each main gear to the cg must be greater than 25 degrees (Equ. 9.18). Here, we consider 30 degrees. Fig. 9.35 illustrates the front view of the aircraft; showing one of the main wheels relative to the aircraft cg.

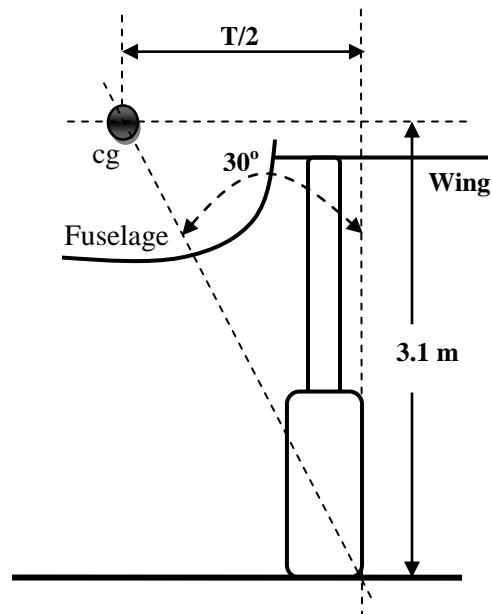
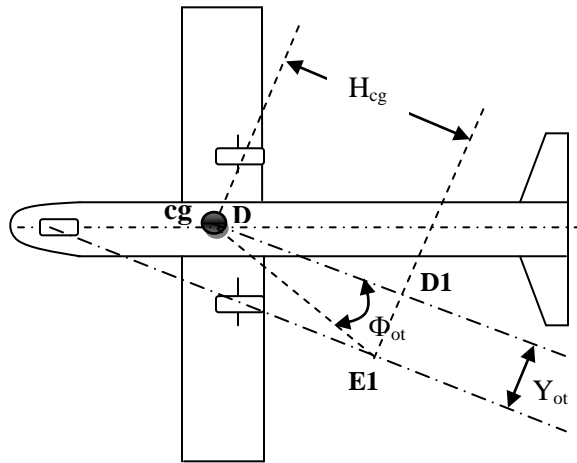

Figure 9.35. Wheel track (front view)

In the step 4, the height of cg from the ground was determined to be 3.1 m. Using the triangle shown in fig. 9.35, the wheel track is determined as follow:

$$\tan(30) = \frac{T/2}{H_{cg}} \Rightarrow T = 2 \tan(30) H_{cg} = 2 \tan(30) \times 3.1 \Rightarrow T = 3.58 \text{ m} \quad (9.x)$$

Now, we need to examine the overturn angle based on the top view. Fig 9.36 shows the top view of the aircraft and a triangle to determine Φ_{ot} based on top-view.



1. Aircraft top view

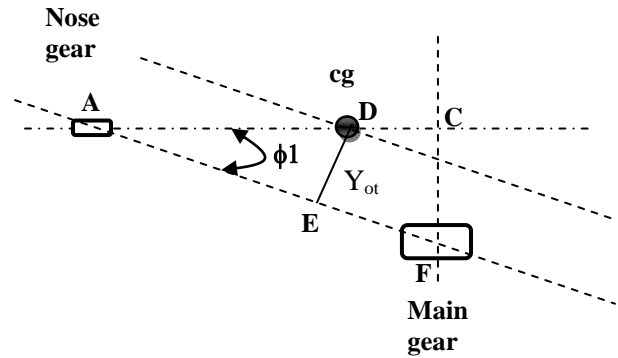

2. Top view (main gear and nose gear)

Figure 9.36. Calculation of the overturn angle for the aircraft in Example 9.8

In order to determine overturn angle (Φ_{ot}), for this aircraft, we first need to determine the parameter Y_{ot} as shown in Fig. 9.36-1. This parameter is calculated by using the sine law in the triangle ADE (Fig. 9.36-2) using the angle Φ_1 . However, this angle is obtained via triangle ACF. In the triangle ABC, the side AC is the wheel base, and the side FC is a one half of the wheel track. Thus, in triangle ACF:

$$\tan(\phi_1) = \frac{BC}{AC} = \frac{T/2}{B} = \frac{3.58/2}{12.775} \Rightarrow \phi_1 = \tan^{-1}\left(\frac{3.58/2}{12.775}\right) = 0.273 \text{ rad} = 15.65 \text{ deg}$$

Similarly, in the triangle ADE:

$$\tan(\phi_1) = \frac{Y_{ot}}{AD} = \frac{Y_{ot}}{B_{n_{min}}} \Rightarrow Y_{ot} = B_{n_{min}} \tan(\phi_1) = (12.775 - 1.916) \tan(15.65 \text{ deg}) \Rightarrow Y_{ot} = 3.042 \text{ m}$$

Finally in the triangle DE1D1, we can write:

$$\tan(\Phi_{ot}) = \frac{E1D1}{DD1} = \frac{Y_{ot}}{H_{cg}} = \frac{3.042}{3.1} \Rightarrow \Phi_{ot} = \tan^{-1}\left(\frac{3.042}{3.1}\right) = 0.776 \text{ rad} = 44.5 \text{ deg}$$

The overturn angle is greater than 25 degrees, so the wheel track satisfies the rule of thumb for overturn prevention requirement. In the later steps, ground lateral control, ground lateral stability, and structural integrity must be examined to validate the wheel track.

Step 10. Landing gear attachment

As a natural selection, the nose gear is attached to the fuselage nose. However, for the main gear, we need to compare the fuselage diameter with the wheel track. It is observed that the fuselage diameter (2.4 m) is smaller than the wheel track (3.58 m). Hence, the main gear cannot be attached to the fuselage. Thus, main gear may be either attached directly to the wing; or attached under the nacelle. In order to determine the best location, several design requirements must be examined, which is beyond the scope of this example. For the time being, it is decided to attach the landing gear to the wing. Thus, the landing gear height will be :

$$H_{LG} = 2.996 \text{ m (as shown in Fig 9.32)}$$

Step 11 through step 29. Mechanical parameters of the landing gear

Although the landing gear we designed so far has satisfied several requirements, but there are still other design requirements which have not been examined. During the design process, several iterations will take place until we have the optimum design. The rest of the landing gear design including examining mechanical parameters such as tire, shock absorber, and strut is left to the reader for practice.

Step 30. Drawing

The calculated dimensions for wheel base, wheel track, wheel height, and the distance between main gear and aircraft cg are illustrated on the drawing in Fig. 9.37.

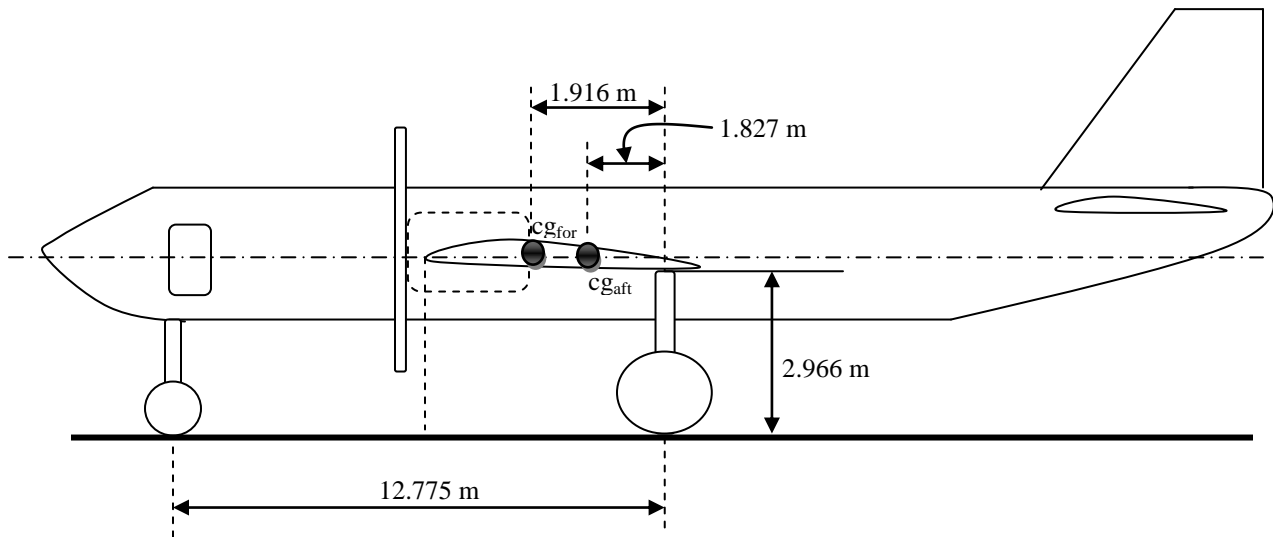

1. Wheel base, landing gear height, and main gear to cg

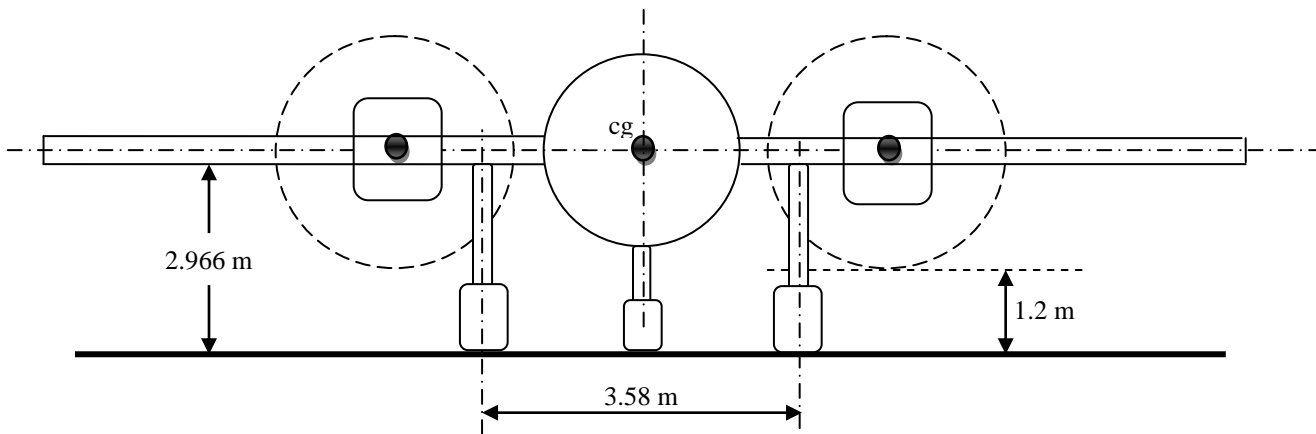

2. Wheel track, clearance, and wheel height

Figure 9.37. The aircraft in Example 9.8 with the designed landing gear (figure is not scaled)

Problems

- Using a reference such as Ref. 5, identify one aircraft with fixed tricycle landing gear, one aircraft with retractable tricycle landing gear, one aircraft with tail gear, one aircraft with quadricycle landing gear, and one aircraft with partially retractable landing gear (either main or nose gear is retracted). For each aircraft, provide name of the aircraft, type of the aircraft and its picture or three-view.
- Using a reference such as Ref. 5, determine the followings:
 - The ratio between wheel track to fuselage length; and the ratio between wheel base to wing span for twin turboprop regional transport ATR 42.
 - The lateral angle between the main wheels off the cg (front-view) for fighter F-16.
 - What percentage of aircraft weight is carried by the nose gear of jet transport Airbus A310? Assume that the aircraft cg is located at 20% of MAC.
- Using a reference such as Ref. 5, describe the features of the landing gear of aircraft Harrier II AV-8B in brief.
- Using a reference such as Ref. 5, describe the features of the landing gear of aircraft Scaled Composites White Knight in brief.

- A pilot of a prop-driven aircraft shown in figure 9.38 is going to take-off with 14 degrees of fuselage angle of attack.

Determine if the aircraft rear fuselage will hit the ground during take-off rotation. If yes, what must be the main gear height to achieve the clearance of 20 cm?

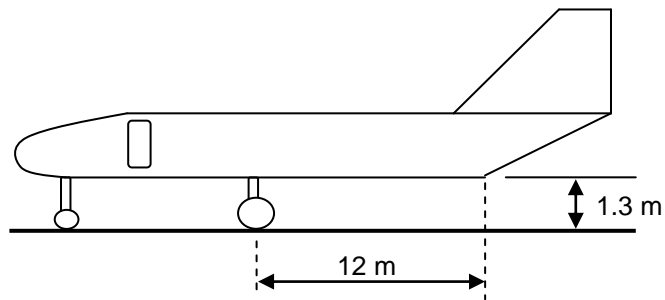

Figure 9.38. Figure for problem 5

- A fighter aircraft is taking off with 16 degrees of fuselage angle of attack. The height of the lowest point of the rear fuselage is 1.4 m and the distance between main gear and the fuselage tail point is 6.8 m. The landing gear is attached to the fuselage. Does the rear fuselage hit the ground during take-off rotation? If yes, determine the main gear height to achieve the clearance of 40 cm.
- A utility aircraft with a mass of 7,000 kg has a tricycle landing gear configuration. The wheel base and wheel track is 11.6 m and 1.9 m respectively and the distance between main gear to aircraft cg is 0.65 m. Determine the static load on each gear. What percentage of the aircraft weight is carried by main gear?
- A large transport aircraft with a mass of 70,000 kg has a tricycle landing gear configuration. The wheel base and wheel track is 25 m and 4.2 m respectively and the distance between main gear to aircraft cg is 1.2 m. Determine the static load on each gear. What percentage of the aircraft weight is carried by nose gear?

9. A twin turboprop aircraft with a take-off mass of 20,000 kg has a tricycle landing gear configuration with a wheel base is 12 m. The aircraft cg is allowed to move between 0.8 m to 1.2 m from the main gear.
 - a. The nose gear is desired to carry a maximum of 10% of the aircraft weight in static equilibrium. Determine the wheel base.
 - b. The deceleration during landing brake is -5 m/s^2 and the acceleration during take-off is 7 m/s^2 . The distance between aircraft cg to the ground is 2.4 m. Determine the maximum dynamic load on each wheel.

10. A large transport aircraft with a take-off mass of 300,000 kg has a tricycle landing gear configuration with a wheel base is 32 m. The aircraft cg is allowed to move between 1.2 m to 1.8 m from the main gear.
 - a. The nose gear is desired to carry a maximum of 18% of the aircraft weight in static equilibrium, determine wheel base.
 - b. The deceleration during landing brake is -7 m/s^2 and the acceleration during take-off is 10 m/s^2 . The distance between aircraft cg to the ground is 4 m. Determine the maximum load on each gear.

11. A jet transport aircraft with a mass of 40,000 kg and a wing area of 85 m^2 is turning on a runway. The ground speed is 15 knot and the turn radius is 25 m. The height of the aircraft center of gravity from the ground is 2.7 m.
 - a. Determine minimum overturn angle to prevent an overturn in this taxi maneuver.
 - b. Determine the wheel track corresponding to this overturn angle.

12. A single engine prop-driven aircraft with a mass of 4,000 kg and a wing area of 14 m^2 is turning on a runway. The ground speed is 18 knot and the turn radius is 15 m. The height of the aircraft center of gravity from the ground is 0.8 m.
 - a. Determine minimum overturn angle to prevent an overturn in this taxi maneuver.
 - b. Determine the wheel track corresponding to this overturn angle.

13. Consider the aircraft in problem 11 is on a runway at 5,000 ft altitude. The aircraft side area is 120 m^2 , and the height of the aircraft centroid of side area from the ground is 2.6 m. A cross wind with a speed of 35 knot is blowing. Assume the aircraft side drag coefficient is 1.1. Determine the minimum wheel track to prevent an overturn due to this cross wind. The lowest possible weight is 25,000 kg when there is no passenger on-board and zero fuel.

14. Consider the aircraft in Example 12 is on a runway at 3,000 ft altitude. The aircraft side area is 16 m^2 , and the height of the aircraft centroid of side area from the ground is 1.2 m. A cross wind with a speed of 30 knot is blowing. Assume the aircraft side drag coefficient is 0.7. Determine the minimum wheel track to prevent an overturn due to this cross wind. The lowest possible weight is 2,000 kg when there is no passenger on-board and zero fuel.

15. An aircraft with a mass of 20,000 kg and wing span of 28 m has a tricycle landing gear configuration. The wheel base is 12 m, and the maximum distance between the aircraft cg and the nose gear is 11 m. The wing is made of aluminum with a modulus elasticity of 74 MPa. Assume that the wing can be

modeled with a beam of I-section with a second moment of area of 0.0025 m^4 . If the maximum allowable wing deflection is 2 cm, determine the maximum allowable wheel track.

16. An aircraft with a mass of 100,000 kg and wing span of 38 m has a tricycle landing gear configuration. The wheel base is 20 m, and the maximum distance between the aircraft cg and the main gear is 1.3 m. The wing is made of aluminum with a modulus elasticity of 70 MPa. Assume that the wing can be modeled with a beam of I-section with a second moment of area of 0.008 m^4 . If the maximum allowable wing deflection is 3 cm, determine the maximum allowable wheel track.
17. A business aircraft (Fig. 9.39) with a take-off mass of 20,000 kg and a wing area of 60 m^2 has two turbofan engines, each generating 25,000 N of thrust. The overall length of the aircraft is 25 m, it has a tricycle landing gear, and the runway is concrete. Assume that the forward cg is at 15% MAC, and wing-fuselage ac is at 22% MAC. The aircraft is equipped with a double slotted flap which is set to generate extra lift coefficient of 0.9 during take-off. The elevator deflection during take-off rotation is generating tail lift coefficient of -1.3.

Some dimensions of the aircraft are shown in Fig. 9.39, and other characteristics of the aircraft are as follows:

$$V_c = 350 \text{ KTAS (at 25,000 ft)}, V_s = 82 \text{ KEAS}, C_{D_o} = 0.022, C_{D_o_TO} = 0.031, I_{yy_mg} = 30,000 \text{ kg.m}^2, AR = 10, C_{m_o} = -0.05, e = 0.87, S_h = 13 \text{ m}^2$$

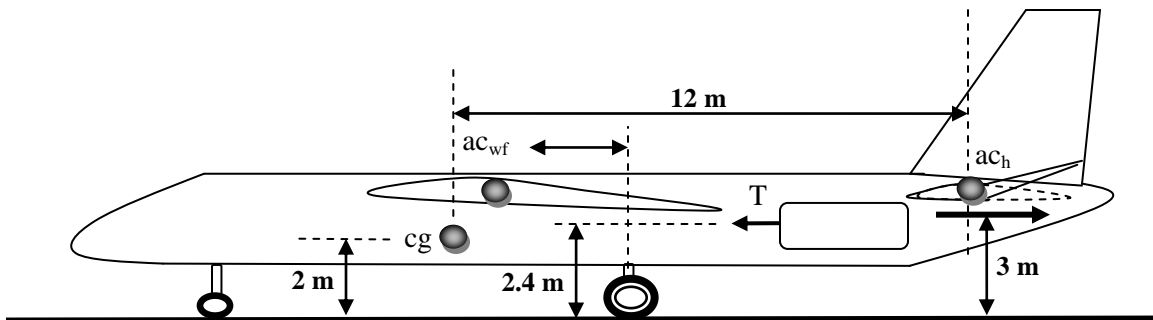

Figure 9.39. Aircraft in problem 17

The aircraft is required to rotate about the main gear with an angular acceleration of 6 deg/sec^2 during the take-off operation at sea level altitude; determine the distance between main wheel to the aircraft forward cg.

18. A transport aircraft with a take-off mass of 15,000 kg and a wing area of 52 m^2 has two turbofan engines, each generating 24,000 N of thrust. The overall length of the aircraft is 17 m, it has a tricycle landing gear, and the runway is concrete. Assume that the forward cg is at 18% MAC, and wing-fuselage ac is at 26% MAC. The aircraft is equipped with a single slotted flap which is set to generate extra lift coefficient of 0.8 during take-off. The elevator deflection during take-off rotation is generating tail lift coefficient of -1.3. Other characteristics of the aircraft are as follows:

$V_c = 440$ KTAS (at 27,000 ft), $V_s = 85$ KEAS, $C_{D_0} = 0.023$, $C_{D_0_{TO}} = 0.032$, $I_{yy_{mg}} = 22,800$ kg.m²,
 $C_{m_0} = -0.06$, $AR = 12$, $e = 0.87$, $S_h = 12$ m², $h_{cg} = 2.2$ m, $h_D = 3.1$ m, $h_T = 1.7$ m, $l_h = 11$ m

The aircraft is required to rotate about the main gear with an angular acceleration of 9 deg/sec² during the take-off operation at 5000 ft altitude; determine the distance between main wheel to the aircraft forward cg.

19. Design a landing gear for the following transport aircraft to carry 25 passengers. The aircraft has two turboprop engines, and is equipped with a single slotted flap which is deflected 20 degrees during the take-off operation on a concrete runway. Assume that the aircraft forward cg is at 14% MAC, aft cg is at 34% of MAC, and wing-fuselage aerodynamic center is located at 23% MAC. The distance between horizontal tail aerodynamic center to the wing-fuselage aerodynamic center is 18 m.

$m_{TO} = 40,000$ kg, $D_{fmax} = 2.8$ m, $V_{max} = 420$ KTAS (at 30,000 ft), $V_s = 75$ KEAS, $D_{prop} = 3.4$ m, $C_{D_0_{clean}} = 0.018$, $C_{D_0_{TO}} = 0.032$, $I_{yy} = 30,000$ kg.m², $P_{max} = 12,000$ hp, $C_{m_0} = -0.02$, $\eta_{P_{TO}} = 0.5$, $\alpha_{TO} = 15$ deg

Wing: airfoil: $S = 100$ m², NACA 64₁-115, $AR = 14$, $e = 0.93$, $\Delta C_{L_{flap}} = 0.9$, $\lambda = 1$

Horizontal tail: $S_h = 25$ m², NACA 0009, $AR_t = 6$, $C_{Lh_{TO}} = -0.9$

The aircraft configuration and other geometry variables are illustrated in Figure 9.40. The following parameters must be determined: landing gear configuration; fixed or retractable; height; wheel track; wheel base; the distance between main wheel to aircraft cg; and applied load on each wheel.

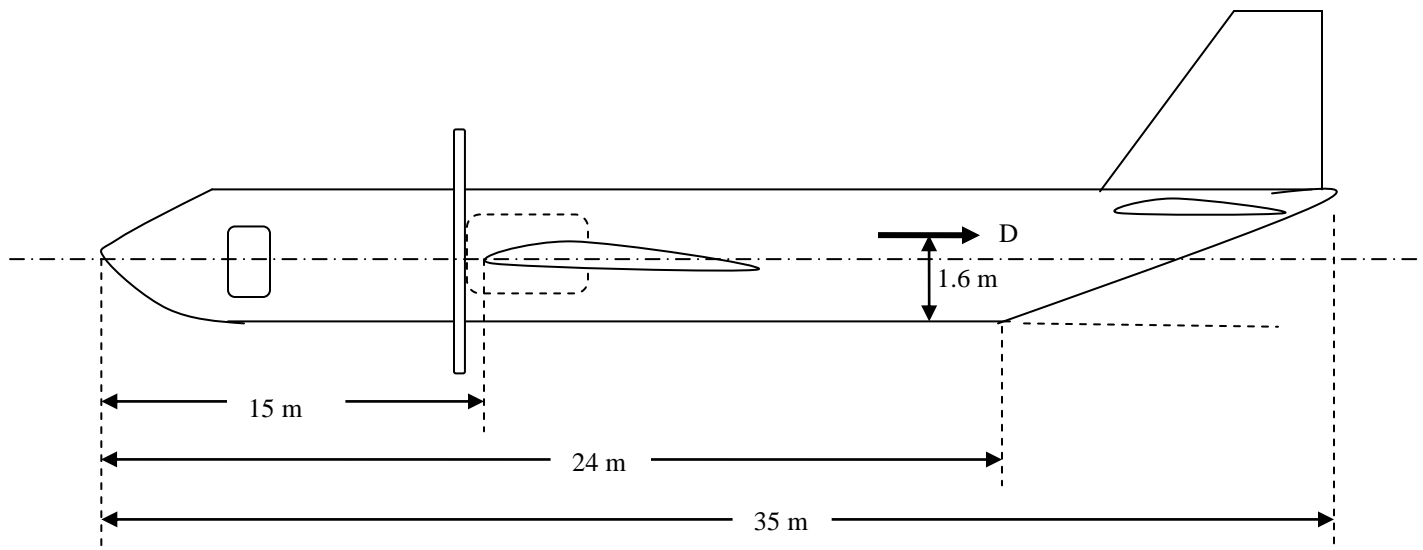

Figure 9.40. Aircraft in problem 19

20. Design a landing gear for the following early warning jet aircraft. The aircraft has two jet engines, and is equipped with a single slotted flap which is deflected 25 degrees during the take-off operation on a concrete runway. Assume that the aircraft forward cg is at 15% MAC, aft cg is at 30% of MAC, and wing-fuselage aerodynamic center is located at 24% MAC. The distance between horizontal tail aerodynamic center to the wing-fuselage aerodynamic center is 26 m.

$m_{TO} = 180,000 \text{ kg}$, $D_{fmax} = 3.5 \text{ m}$, $V_{max} = 460 \text{ KTAS}$ (at 35,000 ft), $V_s = 110 \text{ KEAS}$, $C_{Do_clean} = 0.019$,
 $C_{Do_TO} = 0.028$, $I_{yy} = 3 \times 10^7 \text{ kg.m}^2$, $T_{max} = 2 \times 270 \text{ kN}$, $C_{mo} = -0.06$, $\alpha_{TO} = 13 \text{ deg}$

Wing: airfoil: $S = 320 \text{ m}^2$, NACA 64₁-212, $AR = 10$, $e = 0.85$, $\Delta C_{Lflap} = 1.4$, $\lambda = 1$

Horizontal tail: $S_h = 75 \text{ m}^2$, NACA 0009, $AR_t = 4$, $C_{Lh_TO} = -1.3$

The aircraft configuration and other geometry variables are illustrated in Figure 9.41. The following parameters must be determined: landing gear configuration; fixed or retractable; height; wheel track; wheel base; the distance between main wheel to aircraft cg; and applied load on each wheel.

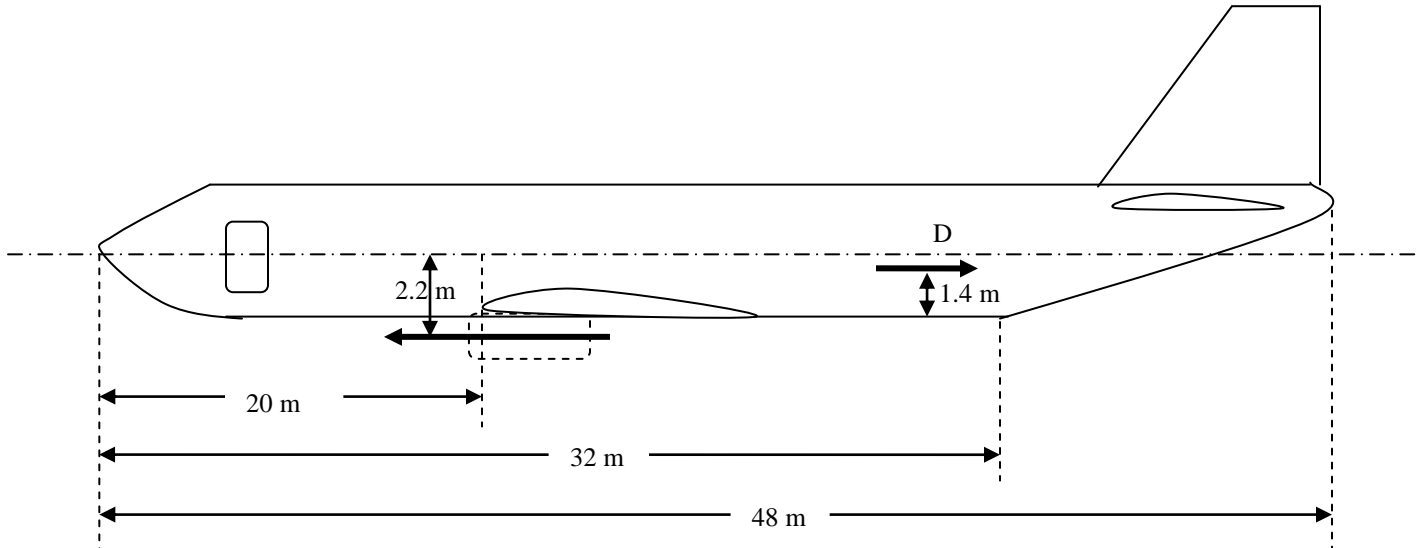

Figure 9.41. Aircraft in problem 20

References

1. Norman S. Currey, Aircraft Landing Gear Design: Principles and Practices, AIAA, 1988
2. FAR Part 23.473, Federal Aviation Administration
3. Russell C. Hibbeler, Engineering Mechanics: Statics, 12th Edition, Prentice Hall, 2009
4. Budynas R. G. and Nisbett J. K., Shigley's Mechanical Engineering Design, McGraw-Hill, 9th Edition, 2011
5. Paul Jackson, et al., Jane's all the world's aircraft, Jane's Information Group, several years
6. Anon, MIL-F-1797C, Flying qualities of piloted airplanes, Air force flight dynamic laboratory, WPAFB, Dayton, OH, 1990
7. Aircraft Tire Data, The Goodyear Tire & Rubber Company
8. Aircraft Tire Data, Bridgestone Corporation
9. Green W. L., Aircraft Hydraulic Systems: An Introduction to the Analysis of Systems and Components, Wiley, 1986
10. Robert L. Norton, Design of Machinery: An Introduction to the Synthesis and Analysis of Mechanisms and Machines, McGraw-Hill, 2008
11. Arthur G. Erdman, George N. Sandor, Sridhar Kota, Mechanism Design: Analysis and Synthesis, 4th Edition, Prentice Hall, 2001