

**Chemistry 421-Lab Manual
Advanced Instrumental Analysis
Prof. Mike DeGrandpre
Spring Semester 2016**



_____ student name

Chemistry 421 Advanced Instrumental Analysis Spring Semester 2016

Instructor: Prof. Mike DeGrandpre, Chemistry Bldg 318, phone: 243-4118, email: michael.degrandpre@umontana.edu, also <http://hs.umt.edu/chemistry/people/default.php?s=DeGrandpre> for additional information. Office hours are during lab hours, 9:10-12:00 Mon.-Thurs. or by appointment. Please go through my lab door, Room 317, to get to my office (not through 318).

TA: Vanessa Selimovic

Lab: Room 119. Student access code is 136831.

Texts: Required: *Principles of Instrumental Analysis*, 6th ed (2007) Skoog, Holler, and Crouch. Also, *Quantitative Chemical Analysis* by Harris, or any other Quantitative Analysis textbook, is an additional helpful resource.

Prerequisites: CHMY 311 or its equivalent is a prerequisite. If you have not taken this course, please talk to me. I assume you have good wet chemistry skills, e.g. ability to use volumetric glassware/pipettes, analytical balances, perform dilution calculations, make up calibration standards, etc. Familiarity with Excel and basic data analysis, e.g. simple statistics, linear regressions, etc. is essential.

Course objectives: In this course you will **1)** obtain a comprehensive knowledge of the theory and practice of instrumental methods used in modern chemical laboratories and **2)** improve your laboratory, data interpretation and technical writing skills. The goal of this course is to develop your lab skills to a point where you can work with confidence in a modern chemical laboratory. To achieve this goal, you will work more independently than you have in previous lab courses. Most experiments are structured to first illustrate the basic operating principles of each instrument followed by analysis of an unknown sample. You will complete the semester with a forensic analysis project where you must identify and quantify an unknown contaminant.

Course logistics: To allow individual access to instruments, it is necessary to run the lab outside of the lab hours scheduled for each section and to team up with a classmate(s). All students must work in groups of two¹. The lab will be open from **8 am - 5 pm Mon-Fri**. This open schedule requires that you be self-disciplined and well-organized (**and safe, see Lab Safety below**). During each lab introduction, it is critical that you take detailed notes when I explain how to operate an instrument so that you can perform the experiments later without repeating explanations. **However, if you are uncertain about a procedure please ask – personal injury or equipment damage may result if proper procedures are not followed.**

¹ Each person MUST analyze their own unknown. Lab group multi-tasking, e.g. one person preparing standards while another does the analyses is not allowed. All lab mates must participate in every aspect of the lab.

Lab notebooks and reports: A bound lab notebook with numbered pages is required. Your lab notebook must be present and open in lab for recording procedures, data, and observations. The notebook and lab report formats are given later in this lab manual. A laboratory report will be turned in for each lab. **All laboratory reports are due in my mailbox at 5 pm on the Tuesday of the week following completion of each lab.** Late reports lose 10% each day thereafter.

Lab Safety: Safety goggles or safety glasses are required. Open toed shoes, food and beverages are not allowed. Working in the lab outside of designated lab hours is not allowed. Corrosive, toxic, and flammable chemicals are used in this class. You must use good judgment when handling all chemicals, e.g. use the hoods when working with volatile substances or gloves when using toxic chemicals. Specific hazards regarding the chemical instrumentation are presented in each lab handout. Please note locations of the eyewash and shower stations. Cleanliness is also an important aspect of a safe laboratory. Please keep the lab clean. **Not following safe lab practices will result in up to a 5% grade reduction.**

Other Stuff: You will need some sort of data storage device (e.g. USB flash drive) for saving data files. Do not rely on the lab computers for storage. Files may be inadvertently deleted. Lastly, I appreciate your help maintaining the lab. Please keep the printers loaded with paper, throw away (or recycle) used paper, fill distilled water (DW) bottles, etc.

Grading: Grades will be on the +/- scale (A, A-, B+, etc) with the following breakdown:

- Homework assignments 5%
- Lab safety 5%
- Labs (7) 45%
- Semester exams (2) 20%
- Independent project 10%
- Final Exam 15%

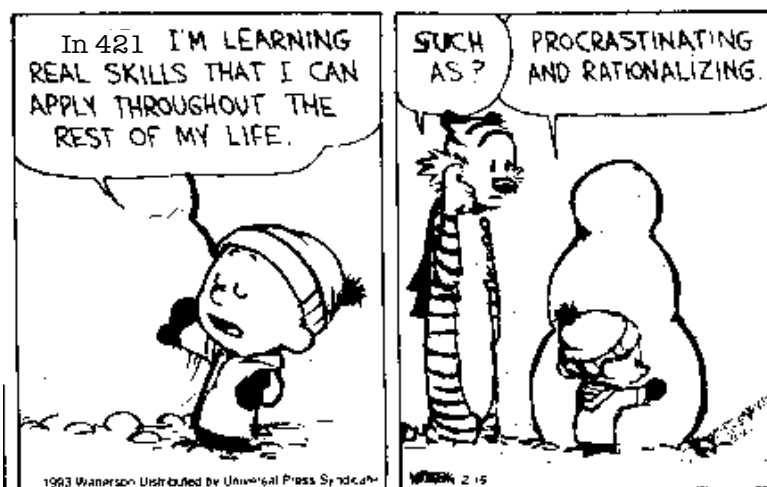

Chemistry 421– Advanced Instrumental Analysis Spring 2016 Schedule			
General topics	Dates	Specific labs	Reading (focus on chapters related to your current lab)
Check-in	1 week Jan 25 – Jan 29	Course intro; lab check in	Chapters: 1, 2A1-3, 2B, 3A, 3B, 3C-1, 4, 5, 22A-C, 23A-D, 23G-H
Topic 1: General lab instrumentation; potentiometry (pH)	2 weeks Feb 1 – Feb 12	Electronics and LabView programming; Computer interfacing and pH measurements	same as above
Topic 2: Spectrochemical methods	5 weeks** Feb 16 - Mar 18	UV/VIS, fluorescence and atomic absorption spectrophotometry	Ch. 6, 7A-H, 8, 9A-D, 10A(1,3)C(1), 13, 14A-D-2, 15
Topic 3: Chemical separations and mass spectrometry	3 weeks ** Mar 21 - Apr 15	GC-MS and liquid chromatography	Ch. 20A-B-1, 26,27,28
Topic 4: Independent project	3 weeks Apr 18 - May 6	N/A	above chapters
Finals Week	3:20-5:20 Tue May 10	N/A	all course material

**Holidays Feb 15 (President's Day), April 4-8 (Spring Break)

Laboratory Notebook Format

The lab notebook is used to document the results of an experiment. The notebook should be bound with page numbers. It can be from a previous class (e.g. 311). You should **always** have your lab notebook with you and open during lab. All entries should be in permanent ink. There is no need to follow a rigid format, but it is important to be as organized as possible. It should minimally contain the following:

- A. Your name and contact information on the outside cover.
- B. Title and date of lab. Also date all additional work if completed on different days. You should take notes in the lab notebook when the lab overview is presented.
- C. Record any changes in the procedure given in the lab manual.
- D. Record all raw data in an organized fashion. **Never** use white out for mistakes, just cross out the error with one or two lines.
- E. Record all relevant observations.
- F. Include chemical calculations (e.g. for making up standards, etc).

Laboratory Report Format

Laboratory reports must be prepared using a word processor such as MS Word, single sided only, with numbered pages, and stapled in the upper left corner. Reports should be well organized and written as concisely as possible but using full sentences throughout. Adding lots of extraneous information won't help (and might hurt) your grade. You can work together with your classmates but each of you must create your own plots and write your own reports. Identical figures, tables or wording will lose 10 pts (of 100 pts total) for each report.

Report format:

- A. Title of lab, your name, your partner's name(s), and date.
- B. General objectives (be brief).
- C. Procedure/Method.
 - 1. Just refer to Lab Manual page numbers but include any changes in the procedure.
 - 2. Include all chemical reactions and chemical structures (for organics)

- directly involved in the analysis.
3. Include examples of relevant chemical calculations, e.g. Beer's Law or the Nernst equation, used to process the data. You do not need to show how to calculate statistics like standard deviations nor concentration calculations.
- D. Results and Discussion (follow Lab report guidelines at the end of each lab).
1. Your data need to be well organized so that it is clear what you've done. Always organize this section using the same outline letters used in the lab handout Results and Discussion, i.e. A, B, C, etc. Don't include any extraneous tables or numbers (e.g data that are shown in a plot usually do not need to be tabulated). Take care to show the proper units and significant figures when reporting results!
 2. Plots can be printed directly from the instrument software or spreadsheet. They may be integrated directly into the discussion or plotted as separate pages, following the section in which they are discussed (**not all stapled at the back of the report**). Take care to label plots properly. Use appropriate axes ranges that clearly show the variability in the data.
 3. When discussing results refer to specific figures and tables (e.g. "*the signal did not drift as seen in Figure 1*").
 4. All homework problems assigned at the end of each lab procedure should be handed in to the TA separately. You can work ahead and hand these in at any time.

Lab report grades will be based on correctly following the lab directions, correct chemical calculations, clear and concise presentation and interpretation of results, and correct lab format. In cases where you analyze an unknown, some of your grade will be based on the precision and accuracy of the analysis and discussion of possible errors.

NOTE: The lab procedure may request that specific data and figures be included in the lab report. Be sure to note these when you do the lab so that you don't forget to put them in your report! Students that reread these directions before turning in a report generally do much better on their reports.

Lab 1: Basic Electronics and Computer Interfacing

Required time: 2 lab periods

Part 1 - *Building a light detector*

I. Overview

All chemical instrumentation uses some form of detector, or *transducer*, to convert chemical information into an electrical signal, such as current or voltage. The electrical signal usually must be processed with additional electronics before it can be output to a readout device such as a computer. For example, electrical current from light detectors and electrochemical sensors must first be converted to voltage and amplified before the signal can be reliably recorded. To illustrate these features we will build our own “instrument” to detect light. The heart of the instrument is the operational amplifier, also known as the op amp. Op amps are useful for a wide variety of signal processing applications, as described in Chapter 3. In this lab we will build an op amp current-to-voltage circuit to convert the current from a light detector (photodiode) into a voltage that can be read into a computer. In Part 2, we will use a LabView computer program to record the analog signal.

II. Procedure

- A. First take some time to familiarize yourself with the multimeter by measuring voltage outputs from the electronic “breadboards” and resistor resistance.
- B. Select 6 different resistors and determine their resistance both by the color code (see chart in lab) and using the multimeter. Record your results in your lab notebook. A resistor (R) can be used to convert a current (I) to a voltage (V), i.e. $V=IR$, also known as Ohm’s Law. The larger the resistor, the larger the voltage output for a given current.
- C. Building and testing the light circuit: Build the op amp current-to-voltage circuit using the diagrams on the following page and the testing breadboards in the lab. The red wire from the photodiode is the signal and the black wire is the common (ground).
- D. Place a piece of tape with a pinhole over the detector to prevent detector light saturation. Test your circuit by observing the output (V_o) when you wave your hand over the detector. The signals should start out negative and should go towards zero when light is decreased if the circuit is properly assembled. If V_o is more negative than approx. -10 volts then reduce the feedback resistance, R_f , or make the pinhole smaller. You can use any appropriate resistor, not just those measured in B above. Readings between -11 to -13 volts that never change indicate that the circuit isn’t put together correctly.

- E. Hook up the small tungsten light source to the 5 volt supply (upper right of breadboard). Attach the detector to the light source and record the output (V_o). Record for 3 to 4 different R_f being sure not to bump the light and change the light input. Repeat two more times with the same resistors, record your results and compare with previous data to make sure the signals are reasonably reproducible. If not, repeat.
- F. Disassemble the circuit if you do not have time to continue to Part 2.

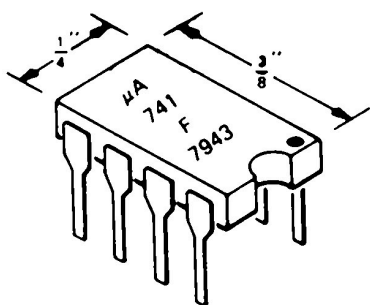
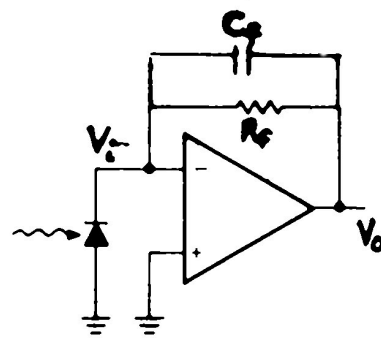
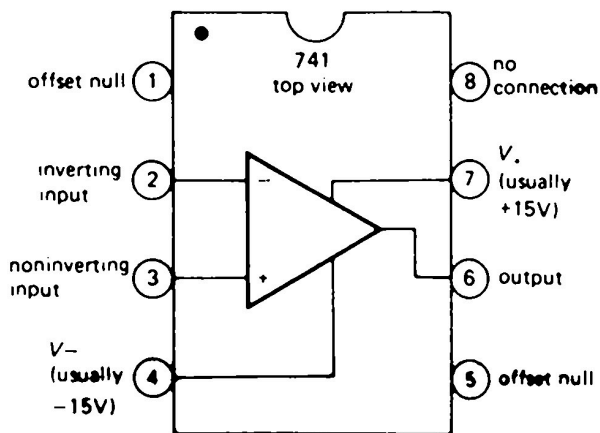

Figure 3.2
Mini-DIP integrated circuit.



Completed circuit



Op Amp pin configuration

III. Results and Discussion

Please complete the following for this portion of your lab report (Chapters 1-5 will be helpful):

- A. Include a table of the resistance according to the color code, the measured resistance for each resistor, and the calculated % error between the color code and measured resistance. Do the resistors fall within the uncertainty specified by the color code?
- B. Include a table with the mean V_o and the standard deviations for the 3 replicates (Part E).

- C. Using spreadsheet software, plot V_o versus R_f . Use the mean V_o and include error bars calculated from the standard deviation in the plot (y-axis only error bars). Remember, always plot the independent, aka fixed or predetermined, variable on the abscissa. Determine the least squares fit to the data and record the slope, y-intercept, and correlation coefficient (r-squared). Include the plot and least squares parameters in your lab report. Remember to include units where appropriate. Calculate the magnitude of the photocurrent that was detected, remembering that $V=IR$. Discuss possible sources of scatter in the data.
- D. Discuss the function of the op amp in detecting small photocurrents.
- E. Give 4 examples of transducers used in chemical analysis that require an op amp (e.g. outputs a current that must be amplified).

Part 2 - Computer data acquisition and analog-to-digital conversion

I. Overview

The next step in Lab 1 is to use automated data acquisition to record the signal from your circuit. Almost all chemical data requires additional computations, modeling, etc., and the best place to do this is on a computer, rather than say, a hand calculator. But how do you read an analog signal, such as voltage, into a computer? You will need an analog-to-digital (A/D) converter to accomplish this task (see Chapter 4). An A/D converter is usually a separately purchased electronics board that is placed within or connected to a computer. Some form of software, either purchased or written by the user, is required to make the A/D board collect the signals in the way that you want. You will use a customized program written in LabView, a sophisticated graphical programming platform, to do this.

II. Procedure

- A. Build the current-to-voltage converter circuit from Part 1. Select R_f so that the output (V_o) is between -1 and -5 volts when the photodiode has only a small pinhole for light to enter. Pick any feedback capacitor (C_f). Record R_f and C_f . Connect the output and ground from the circuit to the appropriate locations on the National Instruments A/D screw terminal board.
- B. Now you will need to look over the LabView program used to handle the data coming in from the circuit to the A/D converter. The program acquires the data, shows it on the computer screen, and saves it to a data file for later import into a spreadsheet program (see the screenshot on the following page). This is a good time to learn a little bit about computer programming so I will explain more during the lab introduction.

C. Now that you sort of understand how the program works, let's collect some experimental data. Before starting the program, unplug the light source to eliminate light on the detector. This procedure collects the "dark signal" and should give you some idea about the light detection limit (to be later computed in a spreadsheet). Run the program for a short period (~40 seconds) collecting data at every ~0.5 seconds (2 Hz), using an R_f value that gives data between -1 and -5 volts.

D. With the same circuit, turn the light on and allow the signal to stabilize for 10 seconds, then collect ~40 seconds of data. Repeat two more times. Copy the data file(s) to memory (e.g. flash). These should be ASCII text files so you can look at them by using a text editor, e.g. WordPad or Excel. Look at the data and make sure that it makes sense before disassembling the circuit.

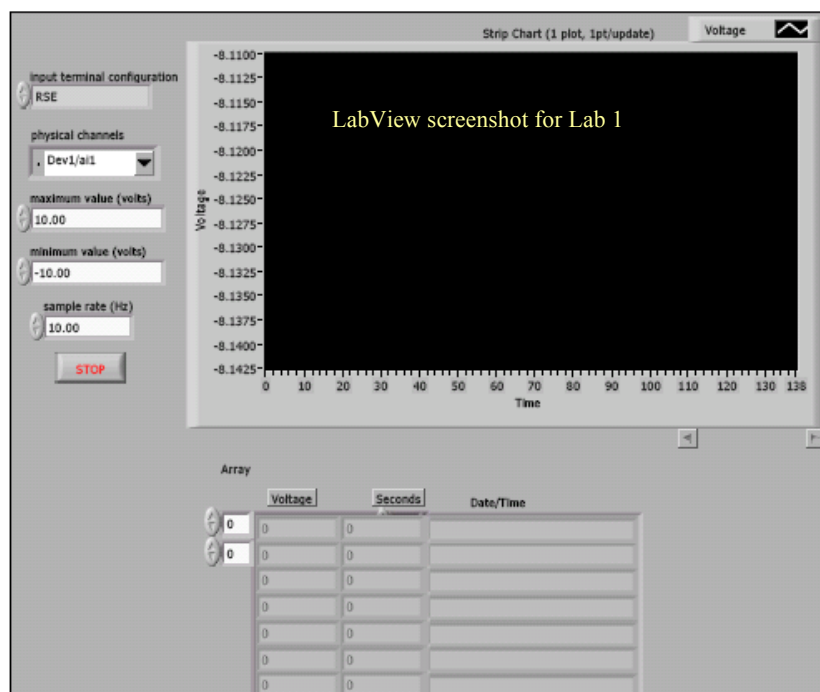

III. Results and Discussion

Please complete the following for the 2nd part of your lab report (Chapters 1-5 will be helpful):

A. Import the data files into a spreadsheet. If it was saved as an ASCII file, you should be able to open it with Excel. If it enters as one line or column, you can break it up into columns by using the Text-to-Columns command under Data (in Excel). For each experiment, including the measurement of the dark signal, calculate the mean, standard deviation (SD), relative standard deviation (% RSD), and signal-to-noise ratio ($S/N=1/RSD$) of V_o . Include in a table in your lab report. Also, generate individual plots of V_o versus time for each trial (expand the y-scale so that variability in the data can be

visually evaluated).

B. The “dark signal” data can be used to determine the detection limit, that is, the lowest photocurrent that you can detect with this circuit is limited by the “dark” baseline noise. If the detection limit is defined as $3 \times \text{SD}$ of the dark signal, what is the minimum detectable photocurrent (in amps)?

C. In your program the voltages were calculated from digital representations of V_o . We used a 14-bit A/D converter, which means that the full voltage input range is split into $(2^{14} - 1)$ pieces. What is the voltage resolution of the A/D converter for the voltage input range used in your program?

D. Compare the S/N of the different trials and discuss differences and possible sources of variability. Determine if the A/D converter resolution adequately resolves the noise by looking at the 40 second data sets.

E. What is the RC time constant of the circuit that you used for the above experiments? Explain its importance.

F. Include a copy of the LabView block diagram with a brief explanation of the function of each icon. Use the LabView help or tutorial to complete.

G. Complete problems 1-10,2-4,2-10,2-14,2-15,4-1,4-4, 4-8,5-5,5-8, 5-10.

Lab 2: Automated Potentiometric pH Measurements

Required time: 2 lab periods

Part 1 - Data collection via serial RS-232 communications

I. Overview

In the previous lab an analog signal was read into a computer via an A/D converter. These days most benchtop chemical instruments perform A/D conversions internally. The digital data is then output to a computer or graphical user interface (GUI). The computer can also be used to control the instrument through specific commands that the instrument can interpret. The commands and digital data are typically transmitted using a “serial” communications protocol named RS-232. Serial digital data is sent one bit after another, in contrast to parallel data transmission where multiple bits are transmitted in parallel lines. For example, the UV/VIS and fluorescence spectrophotometers in the lab both use RS-232 (aka serial) communications with Windows-based software to control the instrument and transmit data. Your objective in Part 1 will be to interface a pH meter to a computer using a serial connection and a LabView program. In Part 2, you will use the program to collect data from the pH meter and evaluate the response characteristics of a potentiometric glass pH electrode. To understand pH electrodes you should read sections 22A-D, 23A-C, and 23H.

II. Procedure

A. We will use a Fisher Accumet AB15+ pH meter for this lab. The meter can be operated either manually, via the input keypad, or remotely, using a computer. Computer communications are made possible by a microprocessor within the pH meter that can understand specific commands sent to it via the serial cable. These commands are described in the pH meter operating manual. First make sure that the communications cable is connected to the 9-pin pH meter connector and the computer's serial communications input, also known as the COM port (now usually a USB port). There are often multiple COM ports, each with an assigned number between 1 and 10. Make sure you know (and record) the port number. It is not uncommon to encounter problems with serial connections but with persistence (trial and error) the problems are readily solved.

B. Put the electrode in a stirred pH 7 buffer solution made from the buffer tablets provided. Without calibration, the meter should output within +/- 1 pH unit of 7 so don't worry for now if the pH meter does not read the correct pH. Set the LabView program up with the input values shown in the screenshot below. The command in the "write buffer" is sent to the pH meter and is interpreted as "print data from the pH meter screen". Using this program, collect data every 1-2 seconds for 1 minute. Make sure the data has been output correctly by viewing in a text editor or Excel. There should be some variability in the data – if the data is a constant value this indicates that the variability is lower than the A/D resolution. If so, please redo the data collection.

C. To test the response time of the sensor, begin collecting data as before using the same stirred pH 7 buffer solution. Quickly pour in ~ 5 ml of pH 10 buffer (also made from the tablets). The pH should change. Allow the pH to stabilize before stopping the program. Save this file.

D. The pH meter outputs a "string" of information that was saved as ASCII text. ASCII, which stands for American Standard Code for Information Interchange, is a format that can be interpreted by any computer and most software packages. ASCII uses 8-bit binary numbered codes to represent keys on the keyboard. The pH meter string includes temperature, an important parameter for pH measurements. Use Wordpad or some other text editor to view. Import the ASCII data file into a spreadsheet. If you import the data as ASCII text, the entire line of data will be imported. If you import as a "comma-delimited" file, only the numbers within each line will be input. Try both. If you need help please ask. You can also convert imported text data to columns as described in the previous lab.

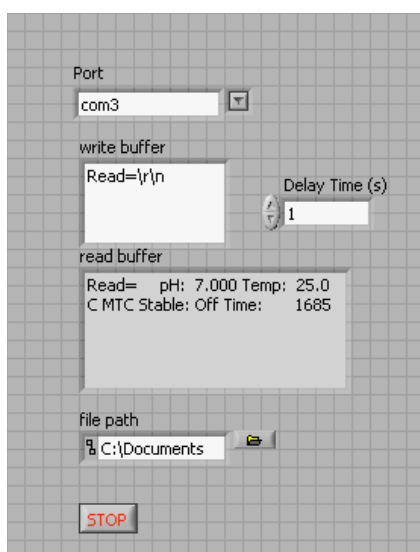

LabView screenshot for Lab #2

III. Results and Discussion

A. Plot pH and temperature versus time for the data you collected in Part 1. Include in your lab report. Be sure to put the data on an appropriate scale so that the variability can be clearly observed.

B. **Figures of Merit:** Pick a ~20 second period from the 1 minute pH data where the signal is not rapidly drifting up or down but also not a constant value. Calculate the mean, standard deviation, % RSD, and 99 % confidence limits for the data during this period. Put the results in a table. Comment on possible sources of noise and drift in the pH measurement (see Skoog's sections on pH electrodes).

C. **Response time:** What is the pH electrode response time, if the response time is considered to be 90% of the total signal change? Discuss.

D. Include a copy of the LabView block diagram with a brief explanation of the function of each icon. Use the LabView help or tutorial to complete.

Part 2 - Evaluation of the performance of a pH electrode using computer data acquisition

I. Overview

Now we will more rigorously evaluate the performance of the pH electrode. The measurement of pH, or $-\log(a_{\text{H}^+})$ is very common because H^+ and OH^- play a role in almost all aqueous reactions. pH is a fairly routine, but deceptively complex, measurement. It can easily be performed incorrectly if the analyst is not familiar with the subtleties of pH electrodes.

II. Procedure

A. Begin by calibrating the combination pH electrode using buffers with pHs of ~ 4, 7, and 10. To prepare the buffers read the directions on the pH buffer vials. Make note of the buffer pH accuracy stated by the manufacturer. All buffers and samples should be stirred with the magnetic stir bar while measurements are made.

B. Calibrate the pH meter using the three pH buffers following the calibration procedure in the pH meter operating manual. Place the pH electrode in the buffer and enter the pH value of the buffer. The meter will automatically read the buffer and calibrate when the signal becomes stable. Also, manually record the mV output for each buffer and the pH of the buffer solution as indicated on the bottle. You will plot these data as part of your results and discussion. Also record the buffer solution temperature for each measurement. Repeat the buffer measurements two more times.

C. **Measurement of a real sample:** Now put the electrode in a pH 7 buffer. Allow the signal to stabilize. Begin collecting data (using the LabView program) with 1 second between data points. After ~ 1 minute, change to a tap water sample and collect data for at least 1 more minute. Using fresh tap water for each measurement, repeat this procedure 2 more times without stopping the program, making note of the time when changing from buffer to tap water. Name the data file and save it.

III. Results and Discussion

A. Include a table of the calibration data (millivolts, pH and temperature). Plot the calibration data (millivolts versus buffer pH) using a spreadsheet program and perform a linear regression. Include a plot of the data and regression along with error bars. In a table, report the slope, y-intercept, r^2 , and error of x estimate (uncertainty in the slope). Determine if the pH electrode is behaving according to theory, i.e. giving a Nernstian response:

$$E_M = E_T + (2.303 RT/F) \log(a_{H^+}).$$

B. Plot the buffer and tap water pH data versus time together on the same figure (continuous in time). Compare the signal stability of the electrode in the buffer and tap water. Explain any differences. Is the tap water pH neutral, i.e. = 7? Why or why not?

C. Discuss proper operation and maintenance of glass pH electrodes.

D. Problems from the book (Ch. 23): 1, 2, 4, 6, 7(a,b,c), 9, 10, 11, 20, 26.

Lab 3: UV/VIS Spectrophotometry

Required time: 3 lab periods

Part 1 - Instrument performance

I. Overview

Photons in the ultraviolet/visible energy range (UV/VIS) promote ground state valence or bonding electrons into higher energy orbitals. This process is called absorption. UV/VIS spectrophotometry takes advantage of these electronic transitions to identify and quantify chemical substances. Chemical identification is possible by recording a spectrum and matching peak location and shape with known spectra. For quantitation, we utilize the linear relationship between absorbance and concentration, i.e. Beer's Law (also known as the Beer-Lambert Law). The primary focus of this lab will be to explore the performance characteristics of a UV/VIS spectrophotometer, the Agilent 8453 (see instrument schematic below). For an overview of optics and spectrochemical instrumentation see Chapters 6 and 7 in Skoog. You should also read Chapters 13 and 14 for specific information about UV/VIS spectrophotometry.

The Agilent is controlled via a computer combined with RS-232 communications and Windows software. In Part 1, you will evaluate the instrument performance and compare the results to the specifications provided by the manufacturer. In Part 2, we will use the Agilent to quantify a mixture of aqueous organic complexes.

II. Procedure

- A. The performance of spectrophotometric instrumentation should always be evaluated prior to collecting any data that you consider important. Most UV/VIS spectrophotometers advertise good wavelength and absorbance (also known as *photometric*) accuracy and precision but, due to use (or abuse), the spectrophotometer may not perform up to par. You will evaluate the wavelength and photometric accuracy. The instrument specs are given in the table below for comparison.
- B. The Agilent should be warmed up ~0.5 hours prior to collection of good quality data but you can collect lower quality data while waiting.
- C. In Windows click on the BOOTP icon with the UV-VIS off. This automatically sets up the communication port for connection to the UV-VIS. Turn the instrument on by pushing the rectangular button on the bottom left corner. Wait

for ~1 minute while the instrument and computer get to know each other.

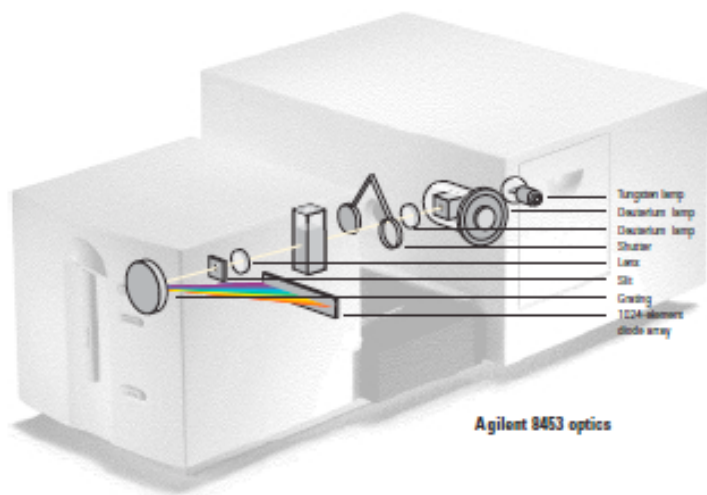
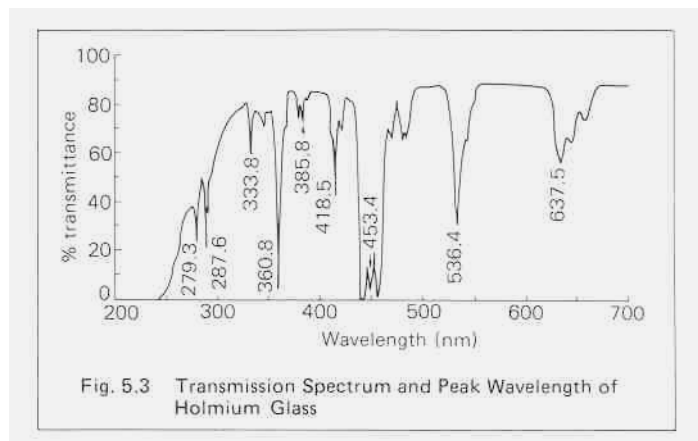

Figure 1: Instrument schematic of the Agilent 8453 UV/VIS spectrophotometer.

Type	Specification	Comments
Resolution	> 1.6	Ratio of absorbance of peak/valley around 269 and 266 nm is greater than 1.5, blank scan on hexane; a 9-point spline function is used; 0.5 s integration time; (EP ⁺ method)
Stray light	< 1.0%	At 200 nm, solution of 1.2% KCl, blank scan on distilled water, 5 s integration time; (EP method)**
	< 0.05%	At 220 nm, solution of 10 g/l NaI, blank scan on distilled water, 5 s integration time; (ASTM method)
	< 0.03%	At 340 nm, solution of 50 g/l NaNO ₂ , blank scan on distilled water, 5 s integration time; (ASTM method)
Wavelength accuracy	< ± 0.5 nm	NIST 2034 standard, using transmittance peak minima; wavelength in NIST certificate are interpolated for 1.5 nm bandwidth from the values given for 2 nm and 1 nm bandwidth; uncertainty of standard from NIST certificate (typically ±0.1 nm) is added to the specification; 99-point spline function is used; 0.5 s integration time
Wavelength reproducibility	< ± 0.02 nm	Ten consecutive scans with NIST 2034 standard; 0.5 s integration time
Photometric accuracy	± 0.005 AU	NIST 930e standard at 1 AU, at 440.0, 465.0, 546.1, 590.0, and 635.0 nm, the expanded uncertainty from NIST certificate is added to the specification; 0.5 s integration time
Photometric accuracy	± 0.01 AU	Potassium dichromate in 0.01 N H ₂ SO ₄ at 235, 257, 313, 350 nm; blank scan on 0.01 N H ₂ SO ₄ ; 0.5 s integration time; blank scan on solvent; (EP method)
Photometric noise	< 0.0002 AU rms	Sixty consecutive scans on air with 0.5 s integration time at 0 AU, 500 nm; 11-point moving average: using equation: Noise(rms)=SQRT((SUM(X-x) ²)/n) where x are measured values, X is a 11-point moving average, n is the number of points
Photometric stability	< 0.001 AU/h	Scan on air at 0 AU, 340 nm, after 1-hour warm up, measured over 1 hour, every 60 s, integration time 5 s; difference between maximum and minimum values are compared to specification; at constant ambient temperature
Baseline flatness	< 0.001 AU rms	Scan on air at 0 AU, 190 - 1100 nm, 0.5 s integration time

- D. Now click on the Agilent UV-VIS icon. Surf around the various menus and get acquainted with operation of the software. You should determine how to 1) save spectral files in ASCII format with file names of your choice and 2) set up the instrument operating parameters for each type of experiment you are performing. The software can be confusing but with a little time and patience you should be able to use it effectively. Try using the online help and manuals (in the drawers) if you have questions.
- E. There are a number of different operating modes (Methods). The basic approach is to click on a Method from the menu, then modify the wavelength range, etc. to fit your experiment. Be sure to note the instrument resolution and integration time (this is the amount of time that the photodiode array collects photocurrent).
- F. *Wavelength accuracy:* The UV/VIS/NIR spectral range on the Agilent 8453 extends from 200-1100 nm (UV 200-400 nm, VIS 400-650 nm, NIR= near infrared 650-1100 nm). The instrument spectral wavelengths are set by use of a diffraction grating and optical slit, as will be discussed in class. The holmium oxide glass filter in the drawer under the Agilent 8453, which has sharp peaks throughout the UV/VIS spectral region, will be used to determine the wavelength accuracy of the instrument. The holmium oxide transmission spectrum is below.



1. To begin, verify that both the UV and VIS lamps are on (find the Lamp listing under one of the menus).
2. Set up the Method to obtain a spectrum. Configure it to obtain a % transmittance spectrum from 200-700 nm. Scan a **BLANK** spectrum with no sample in the cuvette holder.
3. Now place the holmium oxide filter in the cuvette holder. Record the transmittance spectrum from 200-700 nm. Use the software to determine

the wavelengths of the major peaks. You will need to use at least 4 peaks (4 wavelengths). Print the spectrum and results from the peak search. Include the peak search results and spectrum in your report (label with your own Figure and Table numbers).

G. *Photometric accuracy:* Absorbance, or photometric, accuracy is important for UV/VIS quantitative analysis and also for accurate determination of molar absorptivities. Good UV/VIS spectrophotometers should provide accurate absorbances over a wide absorbance range. The Buck Scientific round perforated optical filters will be used to determine the absorbance accuracy of the Agilent 8453.

1. Use the Fixed Wavelength method with $\lambda = 440, 465, 546, 590,$ and 635 nm. Make note of the resolution (bandpass), cuvette pathlength, and integration time.
2. The empty cuvette holder will act as the blank – make sure to push the cuvette clamp in place for each measurement because it may block the beam. After scanning the blank, place each filter (4 filters total) in the cuvette holder. Place the filter so that the oval opening is facing towards the larger box. To determine the measurement standard deviation, perform 3 scans for each filter, taking the filter out each time. This will generate a lot of data - 5λ 's x 4 filters x 3 scans = 60 points - so if you learn how to save the data in ASCII format you won't have to manually enter the data into a spreadsheet.
3. Finally, you need to realize that the light source may drift. You should ALWAYS have some idea about how long you can work without having to run another blank. Since you have little or no experience with this instrument, periodically redo blanks to correct for any drift. One way of checking for drift is to simply scan the blank as the sample (in this case an empty cuvette holder) – if no drift has occurred the absorbances should be very close to zero (i.e. <0.002 a.u.)
4. The known filter absorbances are given in the table below.

Buck Scientific perforated filter absorbances (absorbance units)					
Approx value	440 nm	465 nm	546 nm	590 nm	635 nm
0.5	0.604	0.605	0.612	0.613	0.615
1.0	1.048	1.052	1.060	1.062	1.066
1.5	1.421	1.428	1.448	1.466	1.470
2.0	2.320	2.345	2.469	2.489	2.568

- H. *Photometric precision:* Absorbance, or photometric, precision determines the minimum change in concentration that can be detected. Determine the instrument precision with the 0.5 a.u. filter used above. Record 10 replicate measurements of the filter (w/o removing the filter) at 500 nm.
- I. All cuvettes are not appropriate for any spectral range and it is therefore prudent to scan your cuvette to make sure that it does not absorb light in the spectral range of interest. Obtain spectra of plastic and quartz cuvettes from 200-900 nm, using air (i.e. nothing in the cuvette holder) as a blank, and include them in your report.
- J. Now let's run a "sample" to further illustrate some of the important measurement considerations in UV/VIS spectrophotometry. Setup to scan from 400-800 nm. Place an empty, dry quartz cuvette in the sample holder. Scan this as your blank. Remove the cuvette and fill with distilled water (DW). Scan the water spectrum and print the spectrum with an appropriate scale. This spectrum will look strange (negative absorbances) and it is your job to determine why. Include the spectrum in your report. Interpretation of the spectrum will be part of your lab report.

III. Results and Discussion

- A. Include a Table and spectrum of the holmium oxide filter. Calculate the wavelength accuracy. This can be represented as the standard deviation of the differences. Does the spectrophotometer meet the instrument specification (see Table next to the instrument schematic)? With your knowledge of UV/VIS components and design, speculate on possible sources of wavelength inaccuracy.
- B. Calculate the photometric accuracy at each wavelength as above for wavelength accuracy. Include a table of your results. Does the spectrophotometer meet the instrument specification? Discuss possible sources of photometric inaccuracy.
- C. Calculate the photometric precision (also known as noise). Does the spectrophotometer meet the instrument specification? Discuss possible sources of photometric noise.
- D. Plot the spectra of the plastic and quartz cuvettes in the same figure. Discuss the spectral features and the potential pros and cons of each type of cuvette.
- E. Include the UV/VIS/NIR absorption spectrum of DW from Part J. Absorbance is $A = -\log(I/I_0)$ where I is the transmitted light intensity through the sample (water) and I_0 is the transmitted light intensity through the blank (air, in this case). Look at the water spectrum and comment on the "absorbance" in the visible spectrum where pure water does not absorb light (hint: see example 6-2 in book). As in the example, calculate the apparent absorbance that would result by using air as a blank and DW as a solvent. Compare this to your measured values (at, say, 550

nm). Based on these results, discuss the importance of choosing an appropriate blank solution. **Discuss other spectral features**, e.g. sloping baseline, absorbances in the near infrared (NIR), etc.

Part 2 - Quantitative analysis

I. Overview

One of the most common uses of UV/VIS spectrophotometry is for quantitative analysis of light absorbing substances. It is a fairly convenient quantitative method because absorbance is directly proportional to concentration (Beer's Law) so a limited number of standards can be used to generate a calibration curve. UV/VIS can also be a relatively sensitive yet simple tool. In this part of the lab, we will use the Agilent UV/VIS spectrophotometer to quantify concentrations of two pH indicators, bromocresol green (BCG) and bromocresol purple (BCP) in an aqueous solution.

II. Procedure

- A. The instrument should be warmed up. To check, make sure that repetitive measurements of a blank (say at 500 nm) over a few minutes read the same (and close to 0.000 a.u.). Before performing an analysis you must determine where your analytes absorb light. Obtain the absorbance spectra between 400 and 700 nm for a stock solutions diluted in pH 10 buffer of BCG and BCP. Set up your method to collect a spectrum using a quartz cuvette. Run a blank from 400-700 nm with buffer. Now run the BCG and BCP stock solutions. Determine the wavelength of the peak maximum – this is the wavelength that is most sensitive to changes in concentration (largest ϵ). Record. Print a copy of each spectrum (or export and plot in Excel). **Include the spectra in your report.**
- B. You will be given an unknown sample containing a mixture of the BCG and BCP. To determine the concentrations, you must obtain calibration curves of the complexes at the analytical wavelengths, i.e. the peak maxima – please use 616 nm for BCG and 590 nm for BCP. Note that because the spectra overlap, you need to determine the molar absorptivities at 616 and 590 nm for both indicators. Prepare three standards of each by dilution of the stock solutions. Concentrations need to be determined by trial and error to get the absorbances in an appropriate range. Record the absorbances for each standard and unknown solution at the analytical wavelengths. *Remember to run a blank spectrum to correct for drift if there is a long time period between measurements.* Repeat the measurements 3 times, replacing the unknown sample in the cuvette each time to obtain representative sample replicates. Rerun your blank each time for the most accurate measurements.

- C. Also obtain a spectrum of the unknown mixture. **Include a copy in your report.**

III. Results and Discussion

- A. Include the spectra of the dyes and the unknown. Discuss/compare.
- B. Beer's Law is $A = \epsilon bc$ where A is the absorbance, ϵ is the molar absorptivity at the analytical wavelength, b is the cuvette path length (1 cm in this case) and c is the analyte concentration. Using your calibration results for the two wavelengths, plot A vs. c for each analyte at each wavelength. Obtain linear regressions for each calibration plot. These may be combined on a single plot if labeled clearly. Include (in a table) the slope, y-intercept, correlation coefficient and error in the slope for each line. Also include the estimated ϵ 's in the table.
- C. Unknown: Since absorbance increases linearly with concentration, the total absorbance at each analytical wavelength is equal to the sum of individual absorbances (i.e., $A_{\text{TOTAL}} = A_{\text{BCG}} + A_{\text{BCP}}$). Therefore, with two wavelengths, you have two equations and two unknowns and can calculate the concentrations of BCG and BCP in the mixture. Show your work. Report, in a table, the estimated BCG and BCP concentrations in the unknown for each replicate measurement. Also include the average and SD. Discuss the results. Include spectra of the unknowns.
- D. What type of electronic transitions do you think are responsible for the absorption of light by the organic indicators? Why do the two indicators differ in their absorption spectra?
- E. Discuss the importance of pH in this measurement.
- F. Include a schematic of the Agilent optical layout in your lab report and explain the function of each major component used for absorbance measurements (not the fluorescence components).
- G. Problems assigned from book: Chapter 6 (5, 6, 7, 14, 15, 19), Chapter 7 (3, 9, 12, 13, 18b), Chapter 13 (5, 7, 11, 16, 17, 25), Chapter 14 (2, 9).

Lab 4: Fluorescence Spectrophotometry

Required time: 2 lab periods

I. Overview

Fluorescence is the emission of radiation from a molecule or atom that has been excited by electromagnetic radiation. The spectral regions of excitation and emission depend upon the type of electrons (e^- 's) that are being excited. Inner shell e^- 's are higher energy (X-ray), while bonding/valence e^- 's are lower energy transitions (UV to VIS). An excited state molecule can return to the ground state through vibrations, collisions or by emission of photons, i.e. fluorescence. Vibrational and collisional pathways are favored except in molecules with highly conjugated and rigid structures. Fluorescence spectrophotometry is commonly used for quantitative analysis because of its high sensitivity. Since most molecules do not fluoresce, numerous reagent-based methods have been developed that convert the non-fluorescing analyte into a fluorescent product. We will not perform any reagent-based fluorescence analyses, but it is important to remember that this is another common method for fluorescence measurements.

II. Objective

- A. The objective of this lab is to learn how to operate the Jasco FP-8200 Spectrofluorometer and to gain a basic understanding of the principles behind fluorescence spectrophotometry. You should read Chapter 15 in Skoog to help you complete your laboratory report. A schematic of a spectrofluorometer is shown in Figure 1 on the following page. Light from a xenon arc lamp is used to excite molecular fluorescence. The fluorescence emission is collected at 90° to avoid light from the transmitted excitation beam. The instrument contains both excitation and emission monochromators so that analyses can be performed at a wide variety of wavelengths. Study the instrument schematic until you feel that you understand the basic operating principles.
- B. In Part I we will start with analysis of the simplest possible sample - deionized water (DW). You will find that the spectrum of water shows some interesting spectral features. You will determine the origin of these features and will determine if the instrument is performing according to specifications. In Part II, we will obtain excitation and emission spectra of a fluorescent compound.

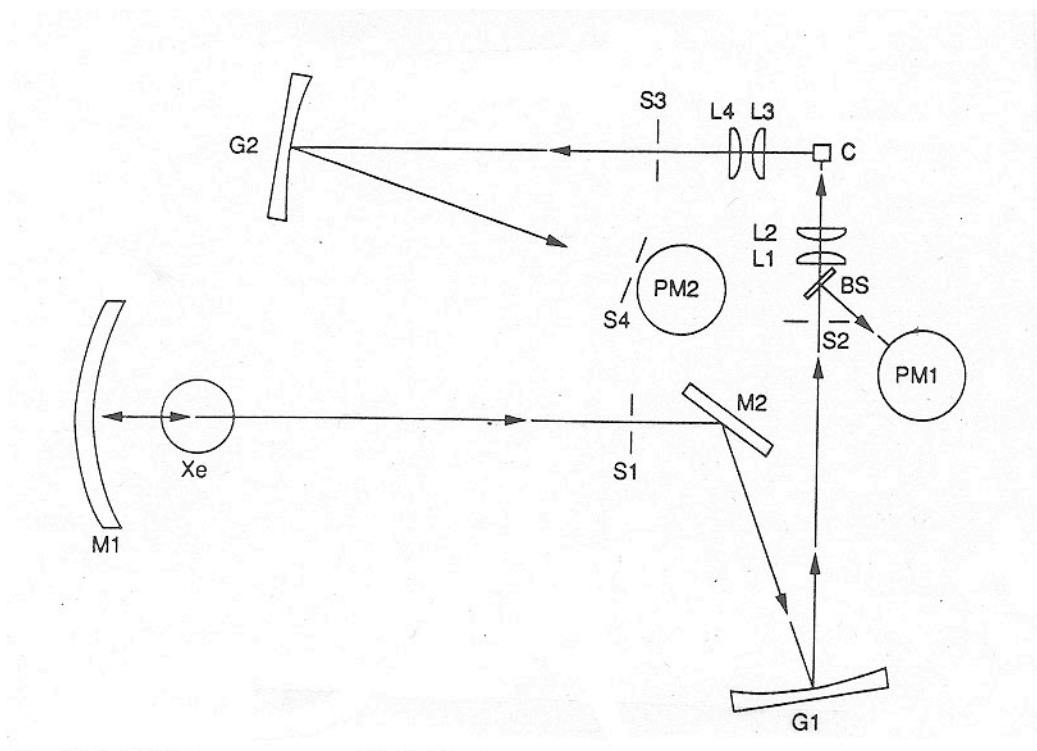

Figure 1: Optical layout of a typical spectrofluorometer. Light emitted from the xenon (Xe) lamp is focused at the entrance slit S1 by the light-concentrating ellipsoidal mirror M1. Light passing through slit S1 is reflected by the plane mirror M2 to the excitation grating G1 where it is dispersed across exit slit S2. The excitation light is focused in the sample cell C through lenses L1 and L2. Part of the excitation light is reflected to a reference photomultiplier tube PM1 from the beamsplitter BS. Fluorescence emitted at 90° is collected with lenses L3 and L4, passes the slit S3 and is dispersed with the emission grating G2. The dispersed light passes through slit S4 onto the photomultiplier tube PM2 for the fluorescence intensity measurement.

Part 1: Operation and Performance of the Jasco Spectrofluorometer

III. Procedure

- A. Like the other instrumentation we've used thus far, an RS-232 interface is used to communicate with the spectrofluorometer. You will use the instrument's Windows software to perform the lab. Find the instrument icon on the computer next to the fluorometer. Please familiarize yourself with the software before proceeding.
- B. Turn the instrument on. Open and close the shutter with the software (under Control). If there is no response (you should hear a click) then the computer and fluorometer are not communicating.

- C. Our first objective is to look at the “fluorescence” spectrum of DW. Set up the instrument with the following conditions:
- Excitation wavelength : 350 nm
 - Emission wavelengths : 360-800 nm
 - Bandwidth : 5 nm
 - Response time : 2 sec.
 - Save data to a file or print a copy
 - Set the shutter in the open position
 - Make sure that the fluorometer is set to collect an emission, not excitation, spectrum
- D. Note that the emission wavelengths do not overlap the excitation wavelength. You must be careful not to scan over your excitation wavelength because this can damage the photomultiplier tube – always set the emission wavelength at least 10 nm greater than the excitation wavelength.
- E. Special nonfluorescing quartz cuvettes are required for low level fluorescence measurements. **They are very expensive and should be handled with care!** Cuvettes should be cleaned thoroughly to eliminate background fluorescence from contaminants. Use soap and warm water and rinse thoroughly with DW.
- F. First hit Autozero. This does not scan wavelengths but zeros the output from the PMT detector. Obtain the emission spectrum from 360-800 nm of an empty cuvette to make sure there is no background contamination (signals should be close to zero). Fill the cuvette with DW. Obtain the emission spectrum from 360-800 nm. The spectrum should show a water Raman peak (see Skoog section 18A) approximately 50 nm from the excitation wavelength in addition to other spectral features. Use the software to record the peak wavelengths and intensities. **Save or print a copy of the spectrum and include it in your report.** The spectrum will be evaluated in your lab report.
- G. Now we will perform another measurement to help you understand the above spectrum. First place the long pass (Fabry-Perot) interference filter provided into the holder in front of the emission lens within the sample compartment, keeping the water-filled cuvette in place. Repeat the scan from above and include the figure in your report. Also, using the Agilent UV-VIS obtain a %T spectrum of the long pass interference filter, referenced to air (say from 300-800 nm). The filter can be attached to the cuvette holder using double sided tape. The filter is called a long pass filter because it transmits λ 's longer than a certain cutoff λ (in this case 400 nm). Make sure your spectrum is consistent with this. Include the %T spectrum in your report. The spectrum will be evaluated in your lab report.

- H. (Remove the interference filter before proceeding). Now determine the fluorometer signal to noise ratio by using the software Time Course mode. Fill the cuvette with water. Set the time response to match the scan conditions in the previous step and choose the wavelength that corresponds to the water Raman peak (excitation =350 nm, emission is ~400 nm). Collect about 20 seconds of data. Save the data. You will use these results to determine if the instrument is operating according to its specifications. **Include a plot of the time-series data in your lab report.**

IV. Results and Discussion – Part I

- A. Include the relevant instrument settings in a table. Include spectra as indicated in lab procedure.
- B. As stated above, the water spectrum should show a water Raman peak approximately 50 nm from the excitation wavelength. The Raman emission is at lower energy (longer λ) than the excitation λ . It is not a fluorescence emission, but corresponds to a molecular vibrational transition which originates from inelastic scattering of the excitation beam. Calculate the shift (also known as a Stokes shift) in wave numbers $\Delta \bar{\nu} = \bar{\nu}_{\text{ex}} - \bar{\nu}_{\text{water}}$ with $\bar{\nu}$ in cm^{-1} . Recalling your knowledge of IR spectroscopy, which IR transition do you think the $\Delta \bar{\nu}$ represents?
- C. Explain the other spectral features in the water scan. Use the results from the interference filter scans to help you explain what is going on. Discuss the potential implications of these results.
- D. The instrument spec for signal to noise (S/N) is claimed to be > 380 for the water Raman peak. Determine if it meets this spec by using the Raman signal intensity and the baseline noise measurement. Run “Time Course” for 1 minute at 400 nm using the DW blank to represent the noise. S/N is the signal average over the standard deviation. Discuss possible sources of S/N degradation.

Part II – *Excitation and emission spectra of a fluorescent compound*

I. Background

Collection of an **excitation spectrum** involves scanning the excitation wavelength while the emission is collected at a fixed wavelength. In contrast, for collection of an **emission spectrum**, a fixed excitation wavelength is used while the emission wavelength is scanned. We will use quinine sulfate in 0.05 M H₂SO₄ as our test compound. **Strong acids are used in this lab – as always, protective eyewear must be worn!**

Make sure the Jasco and Agilent are turned on and warmed up (at least 0.5 hr). Be aware that the fluorophore used in this experiment is highly fluorescing and will create a significant background signal if glassware isn't properly washed (hot soapy water, hot water rinse, methanol rinse, DW rinse).

II. Procedure – Part II

- A. Make up a solution of ~100 mg/L (e.g. 10 mg in 100 mL) quinine sulfate (QS) in 0.05 M H₂SO₄ (density of conc. H₂SO₄ = 1.8305 g/mL). Record the exact concentration.
- B. Use the Agilent to obtain the absorbance spectrum of the QS solution (say from 250-700 nm). Use the appropriate acid solution for the blank. Determine the absorbance maximum. Make sure that the absorbances are in the appropriate range. Place all spectra in your report, including those below.
- C. The concentrated QS used to obtain the absorbance spectrum will be well off scale on the Jasco and need to be diluted prior to the fluorescence measurements. Start with solutions in the low μ M range. Make dilutions with the original solvent solutions (0.05 M H₂SO₄). Obtain the excitation and emission spectra of the dilute QS solution using the following settings: For the excitation spectrum QS: $\lambda_{em} = 450$ nm, 10 nm bandpass, $\lambda_{ex} = 300 - 440$; For the emission spectrum: $\lambda_{ex} = 350$ nm, 10 nm bandpass, $\lambda_{em} = 360-800$. Check to make sure that the signals did not go off scale. If so, further dilution will be necessary - make sure you keep track of all dilutions. Make sure the spectra were successfully saved to a file. Since the fluorometer is very sensitive, take care to wash the cuvette carefully so that no contamination or carry-over from the more concentrated solutions occurs.
- D. Obtain background (no fluorophore) fluorescence spectra using the appropriate solvent with the same settings used to obtain the above spectra. Save these 2 spectra; you will need to subtract the background spectrum from the QS spectra to eliminate contributions from water Raman and scattered light. These change over

time, so make the background scan close to the same time as the other scans. You should initially save the data in the software's binary format if you intend to use the software to background subtract and estimate peak area (see below). You can export the spectra as ASCII files later. It pays to keep careful track of your file names and contents in your research notebook.

- E. Collect a 20 second time course of a blank (350 nm exc./450 nm emission) for estimating the limit of detection (this is the blank reading used in the LOD calculation).
- F. Lastly, collect the absorbance spectrum of the low concentration of QS for comparison to the fluorescence spectra.

III. Results and Discussion - Part II

- A. Include absorbance and blank-corrected emission and excitation spectra for QS. Compare the absorbance, excitation and emission spectra for QS. Explain.
- B. Compare and discuss the LOD for QS using absorbance and fluorescence spectrophotometry (hint: use the baseline noise determined in Part I and the absorbance baseline noise plus the response, i.e. change in signal/unit concentration).
- C. Explain molecular fluorescence.
- D. Discuss possible external (environmental) conditions that can affect fluorescence yields.
- E. Include the instrument schematic with a brief description of the components.
- F. Homework problems: 15-1, 15-2, 15-3, 15-4, 15-5, 15-7.

Lab 5: Atomic Absorption Spectrophotometry

Required time: 2 lab periods

I. Overview

Atomic absorption spectrophotometry (AAS) is widely used for quantifying trace metals in industrial, environmental, and biomedical samples. The instrumentation required for AAS is similar in many ways to that used for UV/VIS molecular spectroscopy. The two primary differences are that the sample must be atomized, typically using a high temperature flame or graphite furnace, and that the narrow absorption bandwidths of the atomized elements require special light sources called hollow cathode lamps. You should read Chapters 8 and 9 in Skoog to help you understand the principles behind AAS.

II. Objectives

The objectives for this lab are to learn the basics of atomic spectroscopy and how to operate an Atomic Absorption Spectrophotometer (AAS). We will use the Thermo SOLAAR S AA located in the lab. A schematic of a typical AA is shown in Figure 1. In Part 1, you will become familiar with use of the AA by establishing the AA linear range for Mg. In Part 2 we will analyze real samples for Mg (you should bring in a sample or samples; however, consult with me prior to running them). NOTE: This lab requires use of explosive gases (acetylene) and caustic acids. REMEMBER TO ALWAYS WEAR SAFETY GLASSES DURING LAB!!

Part I - Instrument Introduction

III. Procedure

- A. Use care in operating the AA to avoid damaging the instrument. If you are unsure of how to do something, please ask! Instrument Operation: directions can be found in SOLAAR Operations Manual – to get started, simple instructions are given on a separate sheet (see below). **To minimize consumption of the combustion gases, never start the flame until you are ready to perform the analysis.**
- B. AAS samples are always acidified to help solubilization and atomization. Prepare a 2% HNO₃ solution in DW for your blank and dilution of your standards. Be aware that AAS is a sensitive analysis. You must use clean glassware to avoid contamination.

- C. Now prepare a set of standards with the acidified DW. We will use these standards to determine the linear range of the Mg calibration. First make up a 100.0 ppm Mg solution. Note: this is 100 ppm with respect to Mg, not the original salt used to make up the solution. Then from the 100 ppm solution make up 100 mLs of 0.5, 1, 2, 5, 10 and 20 ppm Mg standards, recording the exact concentration (3-4 sig figs). If you need additional volumetric pipets, please let me know.
- D. Check to make sure the exhaust hood is on. The hood collects the emissions from the flame.
- E. Turn on the instrument (upper right back panel). Start the SOLAAR software (find icon on Desktop). Username and password are ADMINISTRATOR and solaar, respectively. Click on Method in startup Wizard. Choose the type of flame and continue through menus. Choose Mg from the periodic table. Leaf through the method's sheets. Turn the calibration off. Make note of the settings and **include them in your laboratory report.**
- F. Check the lamp menu that lists the installed lamps to make sure that the Mg lamp is installed. I will show you how to install the lamp if it is not installed. Check the lamp current (power) setting listed on the lamp or lamp box. Incorrect current settings may burn out the lamp. Turn on the lamp under Edit/Lamps.
- G. Open the air cylinder (the tall narrow cylinder) top valve and set the line pressure to 30 psi. Use the small metal scraper to ream out the burner slot. Also, lightly scrape the igniter to remove carbon build-up. Now open the valve on the acetylene tank (the short wide cylinder). The line pressure should already be set at 9-15 psi. NOTE: acetylene is an explosive gas, protective eyewear must be worn at all times. If you attempt to light the flame without sufficient air flow, the acetylene can cause the burner to flashback (backfire). **If the air cylinder is low (i.e., below 200 psi) do not light the flame.** Seek help to replace the cylinder.
- H. You are now ready to ignite the acetylene/air flame. Ask for assistance to light the flame the first time. **Use the white flashing button to ignite the flame and the red lower button to extinguish the flame.** To extinguish the flame, press and hold the red button. The flame will flare up then go out. An additional note: Do not start the flame until you are ready to perform an analysis. Continuous use of the flame quickly empties the air cylinder. Turn the flame off if you are not running samples.
- I. You may need to optimize the lamp alignment and burner position (horizontal and vertical). This will be apparent if absorbance measurements are low (low sensitivity). If you need to adjust the burner or lamp, ask for assistance.

- J. Now you are ready to run your 6 samples. Click on Analyze in the menu. It will ask you to run a blank. Use a pure DW sample (no acid) for this. Insert the aspirator tube into the water. Do not use Kimwipes to clean the aspirator tube because the small tissue particles will clog the tube. Use a DW squirt bottle and a waste beaker to rinse the outside of the tube between samples. Be very careful not to contaminate between high and low Mg standards. The software will automatically prompt you for the sample. Note: your 2% HNO₃ solution should be run as a sample and then subtracted from the sample absorbances because the HNO₃ may have trace Mg. Run all of the Mg standards, manually recording the absorbance of each. You can use the %RSD output as a measure of the uncertainty. **If the 20 ppm sample absorbance is not >0.5 a.u. then something is not working correctly – please seek help.**
- K. After completing the analysis, you can continue to Part II. If you do not have time, run the acidified DW blank for at least 30 s to flush the tubing and burner. Now you are ready to shutdown the instrument. Push and hold the red button to shut off the flame. Close the valve on top of the acetylene tank and push and hold the red button again to purge the line of gas (acetylene can explode if not purged). Then close the valve on top of the air cylinder. Go into the lamp menu and turn off the Mg lamp. Shut off the instrument.
- L. Before leaving, take a look around to make sure everything is properly turned off and cleaned up.

IV. Results and Discussion

- A. Include a table of instrument settings.
- B. Include a table of absorbance and %RSD results.
- C. Make a calibration curve using the average absorbances for the samples from 0.5 – 20 ppm. Include the intercept (0,0) as a data point, since you zeroed to a solution with zero Mg (but don't force the regression through zero). Is the calibration linear, i.e., does the analysis follow Beer's law? To discuss linearity, examine both the trend of the data relative to the least squares line and the correlation coefficient. Also use a 2nd order polynomial (in Excel's plotting function) to determine if the fit improves and include this curve. Explain why AAS often has a limited linear dynamic range compared to say, UV/VIS and fluorescence spectrophotometry.

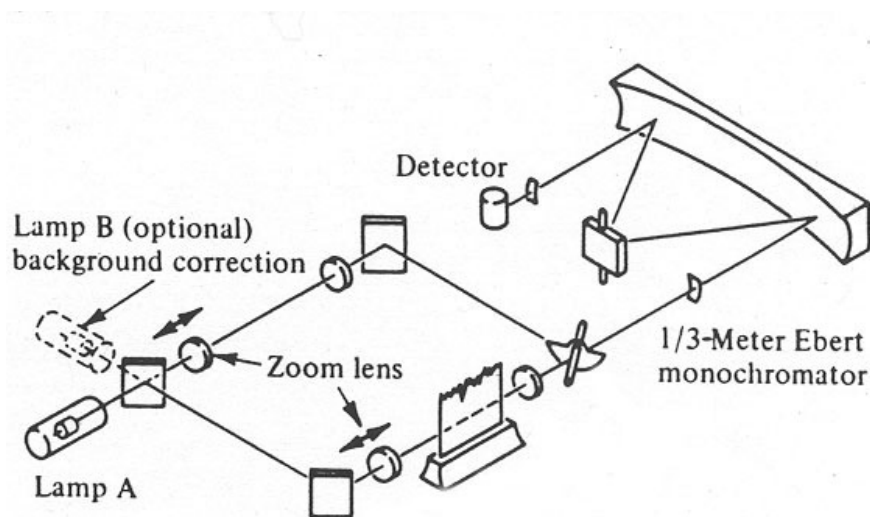

Figure 1: Optical diagram of a typical Atomic Absorption Spectrophotometer

Part II – Chemical analysis using AAS

I. Objectives

Now you will use the AA to determine the Mg content of a variety of aqueous solutions, including an unknown sample and a sample of your own choosing (no particulates please). You will use your standards made up in DW along with the standard additions in the sample to quantify the Mg (see Skoog, section 9D-4,5).

II. Procedure

- A. Follow the procedures given in Part 1 for operation of the AA. Always make sure the proper lamp is installed and that the lamp current is set at the proper current before turning the lamp on.
- B. Prepare another DW blank if not saved from last time. Remember all samples must be acidified with 2% HNO_3 prior to analysis. Also, to avoid clogging the nebulizer, **do not analyze samples that contain suspended solids.**
- C. Change the instrument settings to those used in the previous lab. Make sure all settings are correct before proceeding. Record the settings.
- D. Start the flame and analyze the unknown sample. Also analyze any samples of your own. Reanalyze standards that fall around the absorbance of the sample(s), as determined in Part 1. You should record these results in a table in your laboratory notebook. Dilute the samples if the signals are beyond the expected

linear range of the measurement. If this takes you a while, TURN OFF THE FLAME and redo the analyses after you dilute the samples. Remember to re-run the DW blank from time to time to check for drift.

- E. Turn off the flame. Now we will perform the standard addition measurements on the sample you brought in. If you found that you had to dilute the sample to get it into the linear range, use the diluted sample for this analysis. Estimate the amount of standard that must be added to approximately increase the absorbance by ~25 and 100%, making sure they are in the linear range, if not samples should be further diluted. **Be sure to dilute all standard addition samples to the same final volume.**
- F. Start the flame. Analyze the sample, standards, and standard addition samples.
- G. After completing the analysis, run an acidified DW blank for at least 30 s to flush the tubing and burner. Now you are ready to shutdown the instrument. First turn off the flame, then the instrument power. Close the top valve on the gas cylinders. Before leaving, take a look around to make sure everything is properly turned off and put away.

III. Results and Discussion

- A. Plot the DW and standard addition calibration curves on the same plot and perform a least squares analysis over the linear range for each data set. Note: For the standard addition calibrations, plot the absorbance versus concentration of the standard in the sample.
- B. Use the DW standard curve to determine the concentration of Mg in your unknown. Use the DW standard curve and standard addition calibration to determine the concentration of Mg in your “home” sample. Tabulate and include the mean plus replicate standard deviation (uncertainty) in your report.
- C. By comparing the DW and standard addition calibrations and each calibrations’ estimated sample concentration, determine if matrix effects were significant in your home sample. Explain why or why not. Discuss why matrix effects can be important in AAS.
- D. Briefly describe the function of each component shown in the AA schematic (Figure 1).
- E. Homework assignment: 8-1, 8-4, 8-7, 8-9, 8-11, 9-2, 9-3, 9-6, 9-8, 9-9, 9-11, 9-16, 9-19, 9-20, 9-22, 10-1, 10-2, 10-4, 10-6, 10-8, 10-9, 10-11

**Lab 6: High Performance Liquid Chromatography
(HPLC)
Required time: 3 Lab periods**

I. Overview

Chromatographic techniques are used to separate the components of a mixture before detection and analysis, and can be used to determine the composition of a mixture and the quantity of individual chemical compounds within a mixture. An example would be to determine how much caffeine there is in a cup of coffee. High Performance Liquid Chromatography (HPLC) is an analytical technique for the separation and determination of organic and inorganic solutes in samples. The technique is particularly applicable to biological, pharmaceutical, food, environmental, and industrial analyses.

Chromatographic techniques provide both qualitative and quantitative information. The quality of the analysis is determined by how well separated the analytes are and how “efficient” the separation process is. In order to obtain as much analytical information as possible from a chromatographic separation, it is important to understand the theory and practice of operation.

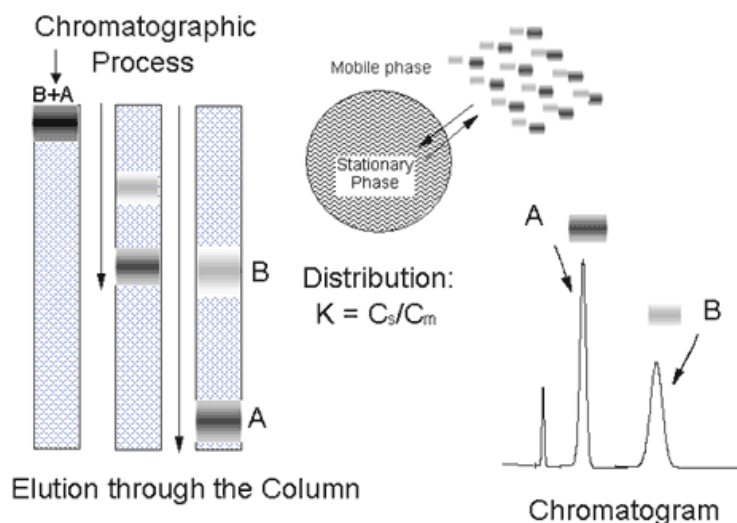

Figure 1: Illustration of the basic chromatographic process.

All chromatographic separations utilize the same basic approach. The sample (a mixture of the analytes and other compounds, including a solvent) is introduced into a flowing stream called the mobile phase. The mobile phase carries the sample through a column that contains a second phase, the stationary phase, which is fixed in place. The analytes partition between the mobile and stationary phases, and those analytes with stronger attraction to the stationary phase

take longer to travel through the column. A detector that responds to the analytes is placed at the downstream end of the column. The detector monitors the concentration of the analytes as they elute from the column, providing a chromatogram. This process is illustrated in Figure 1. Further information on chromatography can be found in Chapter 26 in Skoog, and from Harris, Chapter 23.

The various forms of chromatography are generally classified by the nature of the mobile phase. Gas chromatography utilizes a gas as the mobile phase, while liquid chromatography utilizes a liquid mobile phase. Reversed-phase chromatography, which is the most popular form of HPLC and is the mode that will be employed in this lab, utilizes a non-polar stationary phase and a polar mobile phase. Other modes of liquid chromatography include normal phase (polar stationary phase), ion exchange, and size exclusion chromatography. Further information on liquid chromatography can be found in Chapter 28 of Skoog, from Chapter 25 in Harris.

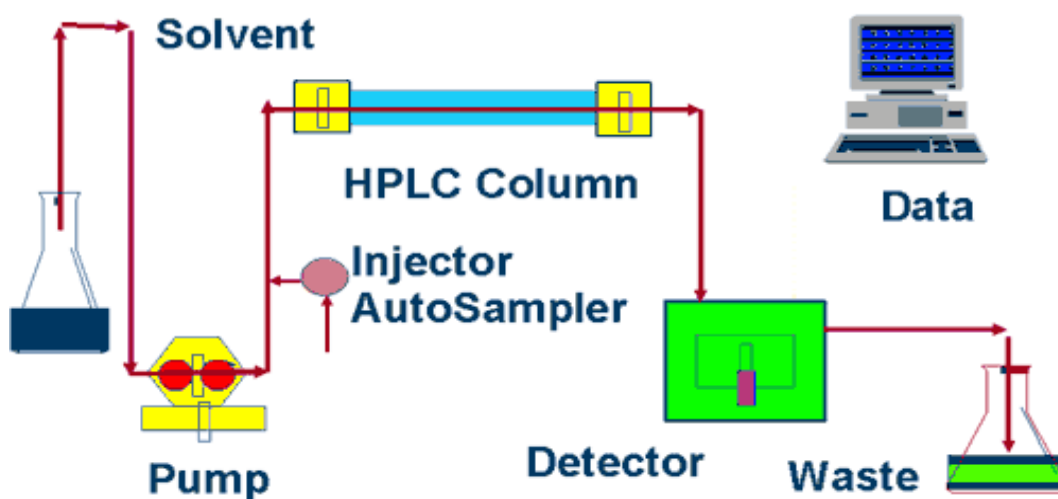

Figure 2: Schematic of an HPLC system.

HPLC instruments consist of a pump, injector, column, detector, and data analysis and control system (Figure 2). The pump is used to force the liquid mobile phase through the column and past the detector. The injector is used to introduce the sample into the flowing stream. The analytes in the sample are (hopefully) separated as they travel through the column, and are then detected by the detector. All of the components are controlled by a computer, which also collects, stores and analyzes the signal from the detector. In HPLC, the column is packed with very small particles (3-10 μm), and high pressures are required to pump the solvent through the system. Thus the pump and all plumbing are designed to generate and withstand high pressure (up to 6000 psi). The injector must also be engineered to allow the sample to be introduced into a flowing stream at very high pressures. The detector on the system to be used in this exercise is a UV/Vis diode array absorbance detector. The system to be used also has two solvent

reservoirs, and is equipped with an electronically controlled metering system to control the composition of the mixed solvent.

A typical chromatogram is illustrated in Figure 3. Important data that can be obtained from the chromatogram are the retention times (t_r), peak widths (w), and peak areas. Retention times can be used to identify compounds, as each compound will (hopefully) have a different affinity for the stationary phase and a different retention time. Peak widths determine the quality, or efficiency, of a separation. Narrow peaks are advantageous because this allows the separation of compounds with similar retention times. The peak area can be used to determine the quantity or concentration of a given analyte in the mixture. Important figures of merit for a chromatographic separation are the retention factor (k), the selectivity (α), the resolution between peaks (R_s), and the plate number or efficiency (N):

$$k = \frac{t_r - t_0}{t_0} ; \quad \alpha = \frac{k_2}{k_1} ; \quad R_s = \frac{t_{r2} - t_{r1}}{(w_1 + w_2)/2} ; \quad N = 16 \left(\frac{t_r}{w} \right)^2 = 5.545 \left(\frac{t_r}{w_{1/2}} \right)^2$$

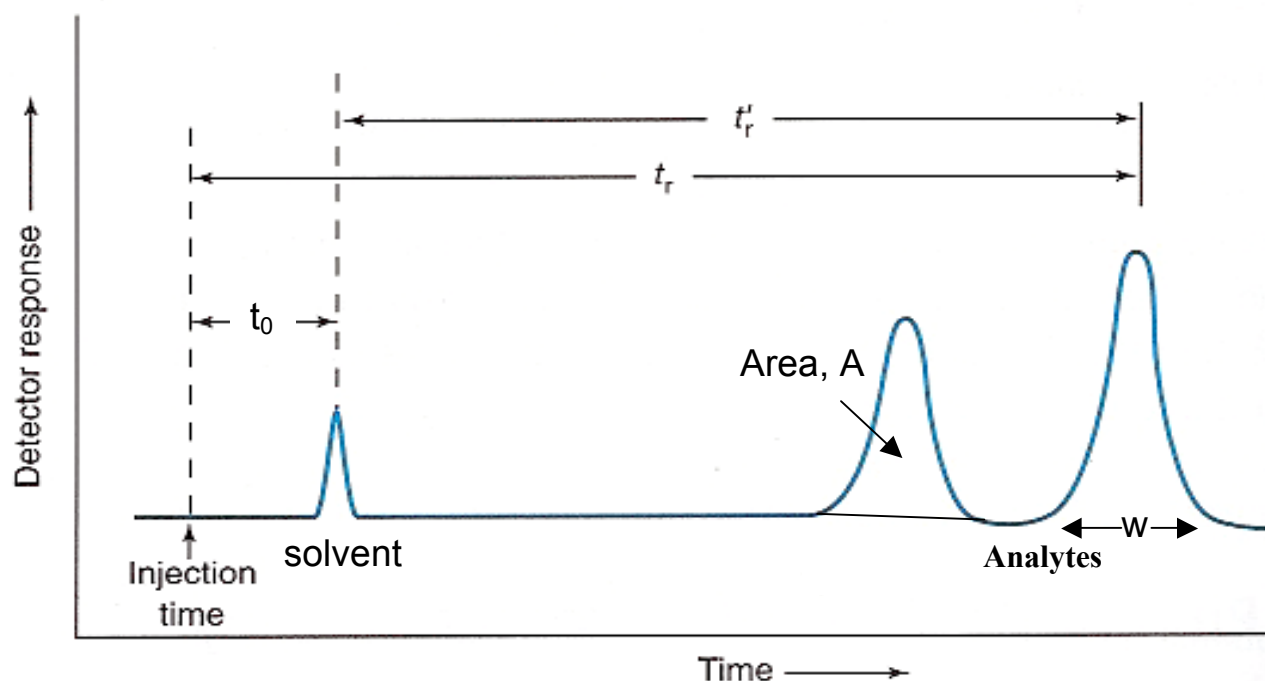

Figure 3: Typical chromatogram.

In reversed-phase HPLC, the stationary phase is lipophilic (hydrophobic or nonpolar), and the mobile phase is a mixed aqueous/organic solvent. The more lipophilic, nonpolar or hydrophobic an analyte is, the stronger is its interaction with the stationary phase. Thus, solutes generally elute from the column with the most polar first and the most nonpolar last. This is illustrated in Figure 4. Additionally, the affinity of all solutes for the stationary phase will be affected by the composition of the mobile phase. As the fraction of organic solvent (acetonitrile in the current exercise) is increased and the fraction of water is decreased, the affinity of all compounds for the stationary phase will be reduced and the retention times will become shorter. A gradient of solvent composition with increasing fraction of organic solvent can be used to elute strongly retained solutes.

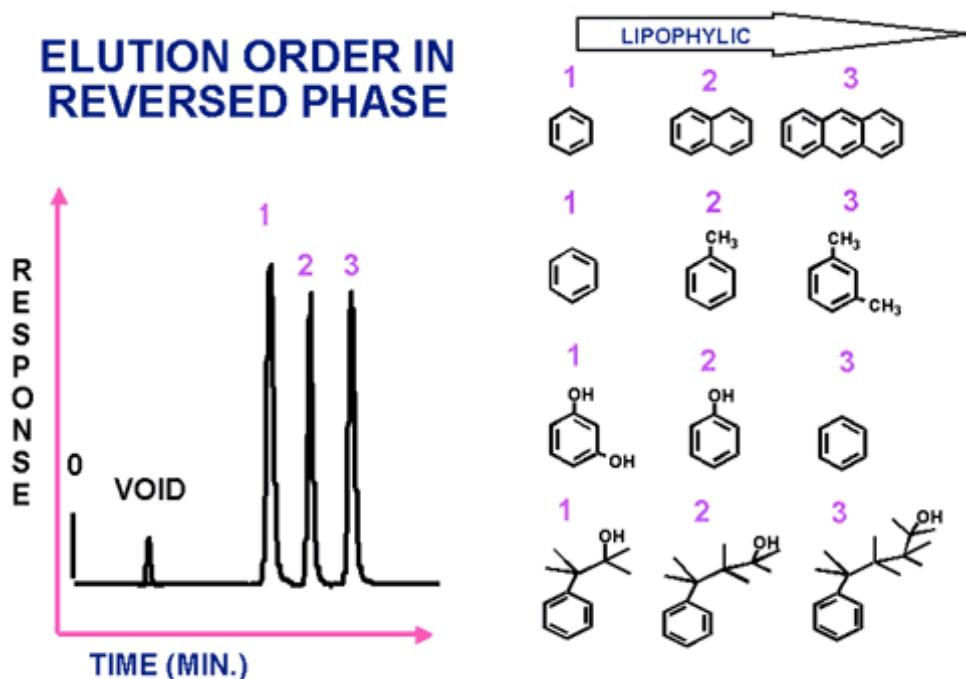

Figure 4: Expected elution order in reversed-phase HPLC.

In this lab, you will separate three sulfonephthalein compounds. Sulfonephthaleins are commonly used as pH indicators and, although similar in structure, they have widely variable aqueous solubilities and equilibrium constants. The three indicators to be separated in this lab are bromocresol purple, phenol red, and bromothymol blue.

II. Objectives

Your objectives are to learn the basics of liquid chromatography and to learn how to operate the Agilent HPLC. You will separate the mixtures using both isocratic and gradient elution methods. The compounds will be identified using your knowledge of reversed phase HPLC and the diode array spectrophotometer detector (like the Agilent 8453 used previously). Various figures of merit will be calculated for the separations.

III. Procedure

A. Starting the HPLC

1. Make sure the instrument is turned on. The instrument power should be left on but the pump and detector should be turned off after use. Start the Chemstation software. From the pump control window, set the flow to 0.1 mL/min and wait for the lamp to warm up. When the lamp is warmed up, the baseline on the plot should stop drifting.
2. To conduct an experiment, load the appropriate method and edit it. Be sure to confirm parameters such as the flow rate (1.0 mL/min), percent B (methanol with 0.05% trifluoroacetic acid), wavelengths of detection (210, 254 and 434 nm), and stop time. Solvent A is HPLC grade water with 0.05% TFA. The injection volume should be 5 μ L.

B. Develop a method

1. **Isocratic separations:** Make separate injections of the mixed standard using 40 and 100% methanol as the mobile phase and a run time of at least 5 minutes for the 40% methanol (less for the 100%). If separated, the chromatograph should have 3 peaks in addition to possible small contaminant peaks. If 3 analyte peaks are not apparent, it is most likely because the concentration of methanol is too high. Be sure to flush the column with the mobile phase composition that will initially be used, e.g. flush with 40% methanol for the first separation. If no peaks elute, flush with 100% methanol to clear all hydrophobic compounds off the column (analogous to turning up the oven temperature in GC separations).
2. Print and save the chromatograms at the three selected wavelengths. Include a copy of the chromatograms and the conditions in your report.
3. There could be a long period between the peaks in the chromatogram(s). This is classic situation (the general elution problem) that calls for a gradient elution method. Based on the two previous separations make some educated guesses about what the initial and final fractions of methanol should be. Keep in mind that the rate of programming should not exceed 10%/min. Be sure to program a return to the initial condition and a “post time” for the column to re-equilibrate before the next injection. Optimize the separation by trial and error. Separations should be <5 minutes for the optimized conditions. Include a copy of the optimized separation and the conditions used in your report.

- C. Remember to turn off the pump and the lamp.

IV. Results and Discussion

- A. In a table, report the settings used for the HPLC including the solvent composition used for both isocratic and gradient elution. Include relevant chromatograms.
- B. Using reversed phase retention theory and the spectral information for the sulfonephthalein compounds, identify each of the three peaks in the mixed standard. Explain.
- C. Discuss the reasoning behind your choices for the gradient separations.
- D. Calculate and report (in a table) the retention factors, selectivity, resolution and average efficiency (N) between each pair of neighboring peaks for the isocratic separations and the optimized gradient separation. Discuss the similarities or differences in the selectivity values between the two separations.
- E. Comment on the gradient separation. Discuss the advantages and disadvantages of the approach, keeping such factors as sensitivity, baseline stability, and total analysis time in mind.
- F. Homework assignment: Chapter 26: 2, 6, 8, 11, 12, 13, 14, 22 Chapter 28: 1-4, 7, 10, 11, 13, 18, 19, 22.

Lab 7: Gas Chromatography-Mass Spectrometry

Required time: 3 lab periods

I. Overview

Gas Chromatography-Mass Spectrometry (GC-MS) is one of the most powerful instrumental methods used by chemists because of its ability to separate and identify the components in complex mixtures.

In chromatography (e.g. GC, LC) analytes are separated because of their differing affinities for the mobile and stationary phases within a chromatographic column. The specific type of chromatography that you choose will depend upon the sample type and the class of molecules or ions that you wish to detect. Gas chromatography is used to analyze gases or volatile compounds typically with molecular weights less than 550. Higher molecular weight and highly polar species are not sufficiently volatile and some molecules decompose at the temperatures used in GC separations. The GC column is enclosed within an oven that volatilizes the sample after injection onto the column. Separation of the mixture occurs when different analytes move faster or slower through the column due to their differing affinities for the stationary phase. Because helium is inert it is often used as the GC mobile phase. The stationary phase is usually a heat-resistant polymer coated on a glass silica support. A large variety of polymer stationary phases are available with variable thicknesses and different extent of polar versus non-polar functional groups. There are also a large variety of detectors for GC's including thermal conductivity detectors (TCD), flame ionization detectors (FID), flame photometric detectors (FPD), and electron capture detectors (ECD). Choice of a detector depends upon the type of analyte and sensitivity required.

In this lab, a Mass Spectrometer will be used for detection. Mass spectrometers are not only very sensitive but they also allow identification of a compound from its unique fragmentation pattern or mass spectrum. Unknown compounds can often be identified by comparison of the spectrum with mass spectral libraries. This allows the analyst to identify peaks within the chromatogram by a few simple clicks of the mouse. In the MS, the substance is bombarded with an electron beam having sufficient energy to fragment the molecule. The positive fragments produced (cations and radical cations) are sorted on the basis of mass-to-charge ratio (m/e). Since the bulk of the ions produced in the mass spectrometer carry a unit positive charge, the value m/e is equivalent to the molecular weight of the fragment. The output of the mass spectrometer shows a plot of relative intensity vs the mass-to-charge ratio (m/e). The most intense peak in the spectrum is termed the base peak. The peaks themselves are typically very sharp, and are often simply represented as vertical lines. The process of fragmentation follows predictable chemical pathways and the ions detected reflect the most stable cations and radical cations that the molecule can form. The highest molecular weight peak observed in a spectrum

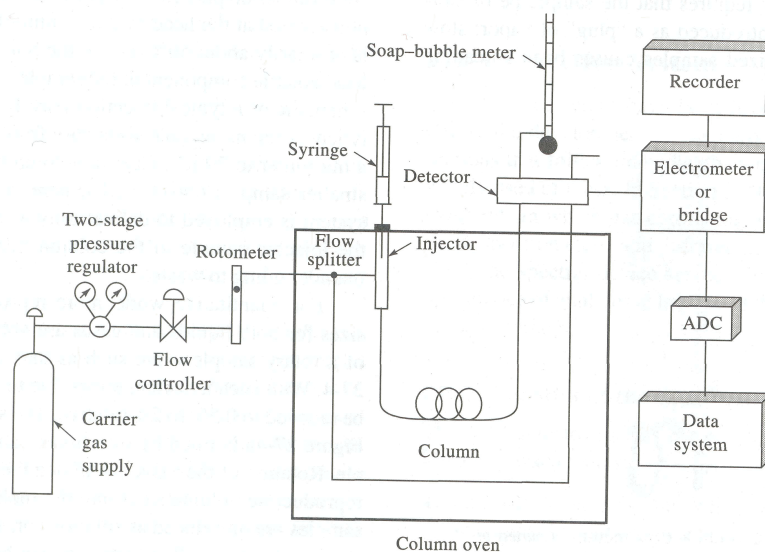

Figure 1: Schematic drawing of a typical gas chromatograph.

will typically represent the parent molecule, minus an electron, and is termed the molecular ion (M^+). Generally, small peaks are also observed above the calculated molecular weight due to the natural isotopic abundance of ^{13}C , ^2H , etc. The mass spectra of fragments with atoms that have unique isotope abundances will reflect that isotope abundance. Fragments can be identified by their mass-to-charge ratio, but it is often more informative to identify them by the mass which has been lost. That is, loss of a methyl group will generate a peak at $m-15$; loss of an ethyl, $m-29$, etc.

II. Objectives

Various mixtures will be analyzed to gain an understanding of the parameters that are used to characterize all chromatograms and to illustrate the power of mass spectrometry. The column on the Agilent GC-MS is a HP-5 column, which is 30 m long, 0.5 mm inner diameter capillary column coated with a 0.25 μm film of 5%-Phenyl-95%-methylpolysiloxane.

As with liquid chromatography, gas chromatograms are characterized by retention times, partition coefficients, retention factor, plate height, theoretical plates, band broadening, and resolution. The objectives of these laboratory exercises are to 1) optimize a separation by changing the separation conditions (temperature in this case) and 2) use the optimized chromatographic results and mass spectrometry to identify the components and estimate concentrations in an unknown mixture and to observe fragmentation and isotope patterns. The mixture is comprised of 10 ppm of each of the following: p-xylene, o-xylene, chlorobenzene and bromobenzene. You will need to read Chapters 26 and 27 in Skoog to complete the lab report.

III. Procedure

- A. **Warning:** GC-MS analysis is limited to samples with low concentrations of volatile substances. Injection of mixtures with significant nonvolatile organics or inorganic salts will contaminate the injection port and may gum up the column and/or contaminate the mass spectrometer. Samples that contain these compounds will require pretreatment before analysis, e.g. extraction into an organic solvent, etc.
- B. You should have your samples prepared prior to running the GC-MS. As always, wear your safety glasses at all times while in lab.
- C. Confirm that the Agilent GC-MS is turned on and that the He mobile phase is flowing.
- D. Familiarize yourself with the GC-MS software. You will use it to set up the instrument parameters. You should click on each icon and set up the appropriate parameters as described during the lab introduction. If you need help on this, please ask Earle Adams, the TA or me before proceeding. The first step is to optimize the separation of the mixture provided. Optimization means resolving the peaks in the minimal time – you should change the temperature conditions so that the separation is complete within ~8 minutes, as described below. Note that filenames larger than 8 characters are not recognized by the software (old software!).
- E. For all analyses inject 2.0 μL of the 10 ppm mixture of compounds with a 10:1 split ratio. You may need to change the split ratio or injection volume if the peaks are too large or too small.
- F. Start by injecting the standard mixture provided and running an isothermal separation (e.g. 70°C) for ~15 minutes. **Do not override the solvent delay, or set the solvent delay to less than 2 minutes.** Determine if all of the compounds eluted. If the least volatile compounds did not elute, increase the column to 300°C and hold for 5 minutes.
- G. Now set up a temperature program. Set the initial temperature at 40 °C for 5 minutes, then ramp at 20°C/min until it reaches 200 °C and hold for 5 minutes. Make sure that all of the compounds on the standard list provided elute from the column and can be identified. There will also likely be small peaks due to trace contaminants in the solvents.
- H. Optimize the separation by adjusting the temperature program or by using

isothermal conditions. You should be able to complete the separation in < 8 minutes with all peaks resolved to baseline. Do not ramp faster than 30°C/min. because faster rates do not allow the oven temperature keep up with the temperature controller. **Include in your report** all chromatograms that effectively illustrate the trial and error procedure that you used to optimize the separation.

- I. Use the total ion chromatogram and the spectral library to identify the different peaks in the final optimized chromatogram. Be sure to **include in your report** the mass spectra for each peak, and the probability from the library search results.
- J. Run the unknown mixture under the optimized conditions (these should be run close in time to the standards). Identify the peaks by retention time and mass spectrum. Quantify the compounds in the unknown mixture using the peak areas (peak integration) and the concentrations given for the compounds in the standard mixture.

IV. Results and Discussion

- A. Include the relevant GC-MS settings for the optimized separation of the standard mixture in a table (oven, injector, etc). Include the relevant chromatograms and mass spectra as requested in the procedure.
- B. Discuss the differences in the isothermal and temperature programming chromatograms.
- C. Using the optimized chromatogram, record in a table the retention time (t_r) and identity of each analyte. Also include boiling points in the table. Explain the order of elution of the different analytes. Explain any missing peaks. Discuss probabilities that the compounds are positively identified by their mass spectra (refer to mass spectra in this discussion).
- D. Report the identity and concentration of the compound(s) in the unknown mixture. Include a chromatogram of the unknown. Include peak areas.
- E. Compare the mass spec fragmentation patterns and abundances (height of MS lines) of chlorobenzene (from the MS library) and the xylene(s). Identify the major fragments.
- F. For the halogenated compound(s), discuss the large peaks around the species' molecular weight. Compare the relative abundances of these peaks and explain.
- G. Homework assignment: Ch. 20 (2, 11, 16), Ch. 26 (10, 21), Ch. 27 (10, 11, 12, 13, 16, 25).