

# ***Vibration Motor***

**Application note**

**Yangyi Chen**  
**April 4<sup>th</sup>, 2013**

***Table of Contents***

***Pages***

Executive Summary ----- 1

1. Table of Contents ----- 2

2. Introduction and Objections ----- 3

3. Electrical Components ----- 4

4. Motor Configurations ----- 6

    4.1 Bar-type Vibration Motors ----- 7

    4.2 Coin-type Vibration Motors ----- 8

5. Motor Selection ----- 10

6. Conclusions ----- 12

7. References ----- 13

## ***Introduction and Objections***

Nowadays, electric motors are commonly used in people's daily life. Imagine that, in an apartment, a man is watching a movie played by his laptop. At that moment, a motor in his computer runs a CPU fan to draw cooler air into the case from the outside, and some motors runs the cd driver so the information on the disc could be read. In the closet, there is a vacuum cleaner, which has a motor on it to run the impeller. Over in the kitchen, there are motors in the refrigerator run the compressor which runs the refrigerant to cool, and run the fan to blow of the heat. Almost every mechanical movement that people could see in the house is made by an AC or DC electric motor. It is not an exaggeration to say that electric motors are everywhere! Haptic technology is one application of electric motors. What is the haptic technology? This technology is a tactile technology that uses the human's sense of touching by applying force, vibration, or motions to users. This physical stimulation can be used to alert users to pay attention to the incoming signals, such as the vibrating mode of cell phones. What's more, haptic technology can also be used to inform users of getting feedback from their previous movements, and this is widely used in gaming systems.

In order to take advantages of haptic technology, defined set of hardware needs to be implemented to create a force feedback system in the internal circuits of the application. Moreover, the output signal need to be able to transferred and successfully read by computer. Through this way, the adjustment of the force can be controlled and modified by computers, which provides the personalized function to different applications. Electric motors can be

configured into DC motor and AC motor based on different type of power supplies. In this application note, the procedures of hardware implements to achieve will be discussed.

### ***Electronic Components***

What is a vibration motor? Vibration motor is a compact size coreless DC motor used to informs the users of receiving the signal by vibrating, no sound. Vibration motors are widely used in a variety of applications including cell phones, handsets, pagers, and so on. The main features of vibration motor is the magnet coreless DC motor are permanent, which means it will always have its magnetic properties (unlike an electromagnet, which only behaves like a magnet when an electric current runs through it); another main feature is the size of the motor itself is small, and thus light weight. Moreover, the noise and the power consumption that the motor produce while using are low. Based on those features, the performance of the motor is highly reliable.

The vibration motors are configured in two basic varieties: coin (or flat) and cylinder (or bar). There are some components in both of their internal constructions.

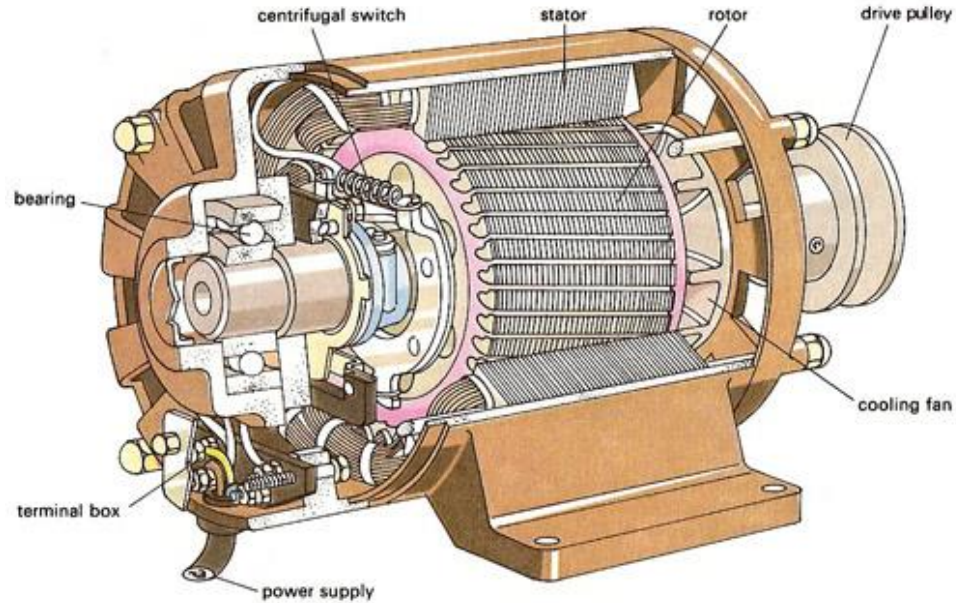

Figure 1

- *Rotor:*
  - The rotor is the non-stationary part of a rotary electric motor. The wires and magnetic field of the motor are arranged so that a torque is developed about the rotor's axis. In some designs, the rotor can act to serve as the motor's armature, across which the input voltage is supplied.
- *Stator:*
  - The stator is the stationary part of a rotary electric motor. It could be worked as the magnet field and interact with the armature to create motion. Another function of the stator is it could act as the armature, which receives its influence from moving field coils on the rotor.
- *Commutator:*
  - A commutator is a rotary electrical switch in certain types of electric motors or electrical generators that periodically reverses the current direction between the

rotor and the external circuit. In a motor, it applies power to the best location on the rotor, and in a generator, picks off power similarly. As a switch, it has exceptionally long life, considering the number of circuit makes and breaks that occur in normal operation.

- *Armature:*
  - The armature in this motor is a set of thin metal plates stacked together, with thin copper wire coiled around each of the three poles of the armature. (How the electric motor works) The main function of the armature is to convert the magnetic energy into the kinetic energy.
- *Windings:*
  - Windings are consisted with some turns of coils. These coils are assembled to generate a magnetic field once electricity goes through them.
- *Weight:*
  - In order to make a vibrating alert, a weight mass need to be attached to the shaft. Through the high speed displacement of weight, the vibration can be achieved. Moreover, the magnitude of the force can be controlled and adjusted, and the factors that could affect it will be discussed below.
- *Brushes:*
  - In motor's shaft, the brushes conduct the current between stator and coils. The life of the motor depends on when the brushes will be worn out. Based on this factor, brushless dc motor, which is also called BLDC, is used to extend the life of motors.

## *DC Vibration Motor Constructions*

- *Bar-type Vibration Motor:*

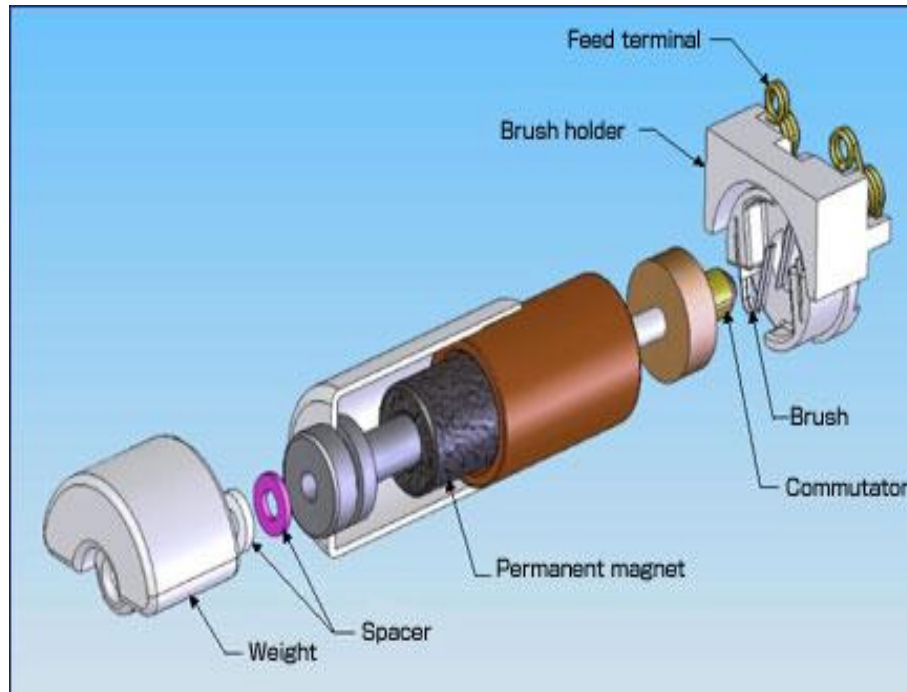

Figure 2

The cylinder shape is also called bar-type vibration motor. This vibrating motor is essentially a motor that is improperly balanced. In other words, there is an off-centered weight attached to the motor's rotational shaft that produces a centrifugal force while rotating. This unbalanced force displaces the motor. Its high speed displacement makes the motor to wobble, which is known as the “vibrating”. The wobble can be changed by the weight mass you attach, the weight's distance to the shaft, and the speed at which the motor spins. What’s more, the centrifugal force, which is generated by the rotating an unbalanced weight, causes the motor vibrate in 2 axis (Z axis and X axis). Besides, the centrifugal force can be calculated through the equations on figure 3. According to the relationship of each components in this equation, it is easy to tell that a larger weight

mass with a bigger offset from the shaft will produce more force and hence more vibration amplitude. Moreover, increasing the voltage supplied to the motor will increase its speed, and therefore the vibration frequency, as well as the vibration amplitude.

**Frequency**

$$f_{vibration} = \frac{(Motor\ RPM)}{60}$$

**Force**

$$F_{vibration} = m \times r \times \omega^2$$

m = the mass of eccentric weight  
r = mass' offset distance  
 $\omega$  = speed of the motor (rads<sup>-1</sup>)  
 $\omega = 2\pi f$

Figure 3

- *Coin-type Vibration Motor:*

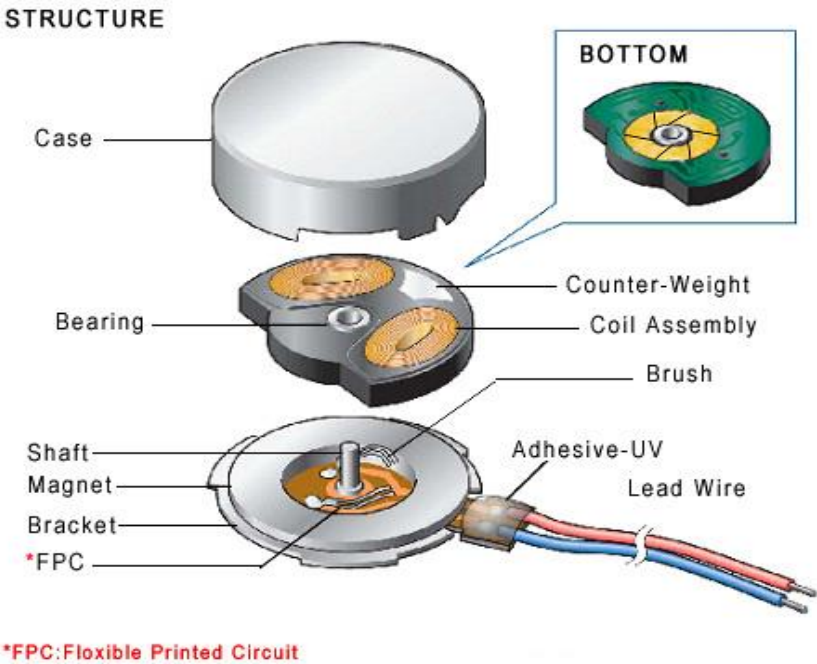

Figure 4



The need for smaller, thinner designs led to the adaptation of brush motor technology into the coin-type vibration motor. Figure 4 is an internal construction diagram of the brush coin-type motor. Similar to the bar-type vibration motor, coin-type vibration motor is comprised of a weight, a ring magnet, rotor with commutation points attached in the front and coils assembled on the back, and power supplied brushes attached to the ring magnet. The commutation points, which are the yellow part on the bottom pic, are in contact with the end of the brushes. It will energize the electrical coils in the rotor. Energizing the coils produce a magnetic field and it is strong enough to interact with the ring magnet integrated into the stator, causing rotation. A force is generated due to the magnetic field. This force causes the weight to displace. The repeated displacement of the weight produces a varying force which is felt as vibration. The commutation points are used in changing the polarity pairs, so that as the rotator moves, the coils are constantly reversing the polarity.

***Motor Selection:***

Figure 5

Figure 5 is a diagram that shows the role of motor in the operating system. Selecting a DC motor for a particular application, some factors need to be considered and clarified: How much power is needed, how much electrical power is available, the space capacity, and so on.

- Load:
  - Load is defined as the output of a circuit connected to the device. In motor selection, load can be defined as the torque needed to operate the whole system. The magnitude of load can be a constant, or it can be varied by time.
- Power:
  - Power is the product of speed and torque. The maximum power of a DC motor is produced at the operating point that is defined by operation at half the no-load speed and half the stall torque.
- Torque:

- The relationship between torque and speed is called a characteristic of the operating system. This DC motor's characteristic varies based on three different magnetization sources: separately excited field, self-excited field or permanent-field, which is used selectively to control the motor over the mechanical load's range.

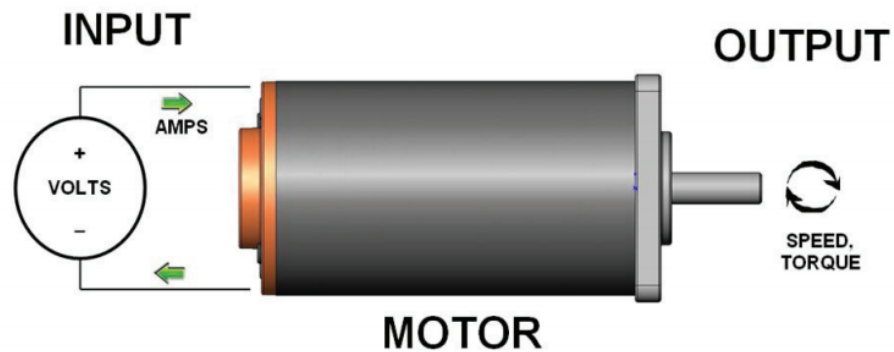
Beside these requirements, some restrictions exist as well that limit the motor selection.

The major constraint on motor operation is thermal in nature. The heat a motor must dissipate can always be calculated as follows:

$$P_{dis} = I^2 \times R$$

Heat dissipated= current through the motor squared, multiplied by the terminal resistance.

The current through a motor is determined by the torque the motor produces. Current and torque are related by the torque constant of the motor:

$$I = M_o / k_M$$

Current through motor = torque produced divided by the torque constant

## ***Conclusions***

This application note detailed on introducing the function of electric components in DC motors. After that, bar-type and coin type vibration motor were introduced, and their working theory were described. The reasons why users can feel vibration through using applications of these two motor were discussed as well. In the end, requirements and restrictions about motor selecting were discussed.

## ***Reference***

“Rotor (electric)” Wikipedia

<[http://en.wikipedia.org/wiki/Rotor\\_\(electric\)](http://en.wikipedia.org/wiki/Rotor_(electric))>

“Commutator (electric)” Wikipedia

<[http://en.wikipedia.org/wiki/Commutator\\_\(electric\)](http://en.wikipedia.org/wiki/Commutator_(electric))>

“How Electric Motors Work”

<<http://electronics.howstuffworks.com/motor3.htm>>

“Electric Motor”

<[http://www.daviddarling.info/encyclopedia/E/electric\\_motor.html](http://www.daviddarling.info/encyclopedia/E/electric_motor.html)>