

CIRCUITS WORKSHEET

1. Determine the equivalent (total) resistance for each of the following circuits below.

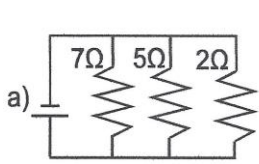

$R_{eq} = \underline{\hspace{2cm}}$

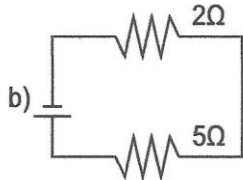

$R_{eq} = \underline{\hspace{2cm}}$

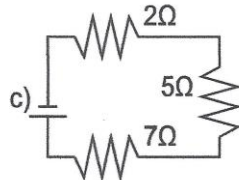

$R_{eq} = \underline{\hspace{2cm}}$

2. Determine the total voltage (electric potential) for each of the following circuits below.

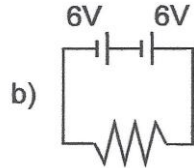
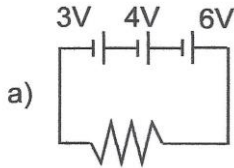

3. In a series circuit there is just one path so the charge flow is constant everywhere (charge is not lost or gained). Circuit **B** was made by adding 2 more identical resistors in series to circuit **A**

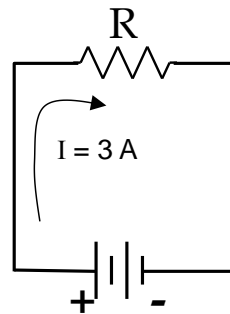

Circuit A

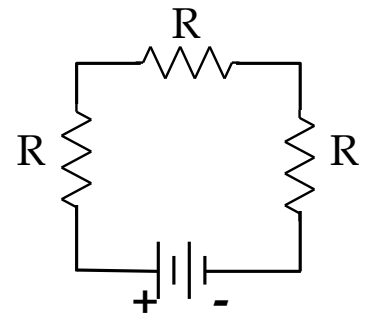

Circuit B

a) How is the charge flow out of the battery (and back into it) affected by adding more bulbs in series?

b) If the resistors were light bulbs, how do you expect the brightness of the bulbs to be affected by adding more bulbs in series?

c) How is the brightness in the 2 circuits related to charge flow or current?

d) How does the current in circuit B compare to circuit A?

e) How is current (I) related to the resistance of the circuit?

f) If the resistance of a circuit is quadrupled, by what factor does the current change?

g) Fill out the table for the circuit diagramed at the right.

Circuit Position	Voltage (V)	Current (A)	Resistance (Ω)	Power (W)
1			10.0	
2			20.0	
3			30.0	
Total	6.00			

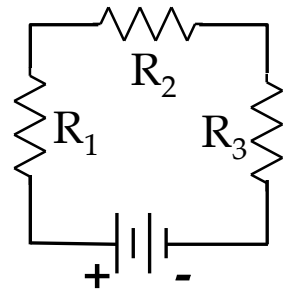

h) Is there a relationship between resistance and voltage drop in a series circuit? If so, state it.

i) If the resistors were light bulbs, explain in terms of charge flow (current) and energy per charge (voltage) which bulb would be brightest / dimmest

4. In a parallel circuit, there is more than one loop or pathway so charge flow gets split up or recombined at junction points. Therefore current is not the same at every point in the circuit

a) How does the current through the one resistor in circuit A, compare to the current through each resistor in circuit B? (Use Kirchoff Loop rule on circuit B to look at the current in each path.)

b) How does the sum of the currents through the three bulbs in circuit B compare to current from the battery in circuit A?

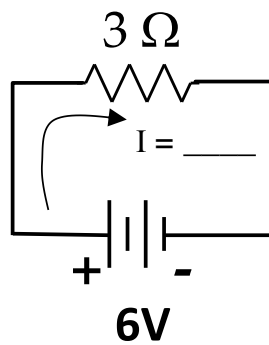

Circuit A

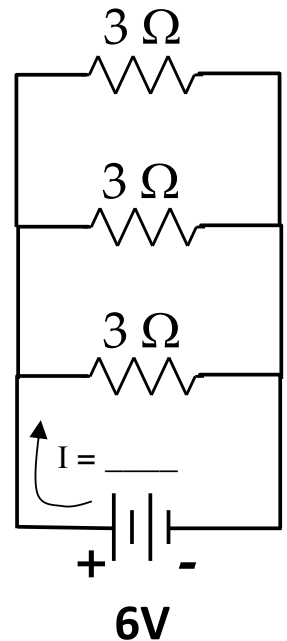

Circuit B

c) How is the current out of the battery (and back into it) affected by adding resistors in parallel? Explain

d) If the resistors were light bulbs, how does the brightness of each bulb in circuit B compare to the brightness of the single bulb in circuit A,?

e) How is the resistance of a circuit affected by adding additional pathways?

f) Fill out the table for the circuit diagramed at the right.

Circuit Position	Voltage (V)	Current (A)	Resistance (Ω)	Power (W)
1			10.0	
2			20.0	
3			30.0	
Total	6.00			

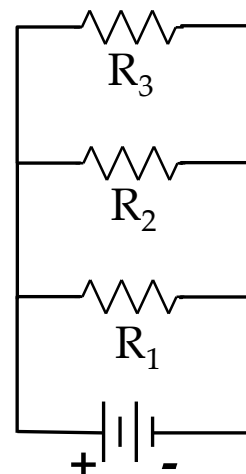

g) How does the voltage drop across each branch in a parallel circuit compare?

h) If the resistors were light bulbs, explain in terms of charge flow (current) and energy per charge (voltage) which bulb would be brightest / dimmest.

5. Consider the circuit at right. Assume the resistors are identical.

a) If the resistors were light bulbs, rank them from least to most bright. Justify your answer.

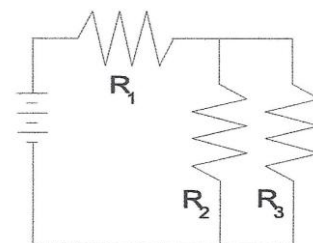

b) If bulb 1 were removed, leaving a gap, what would happen to the brightness of the remaining bulbs. Justify your answer.

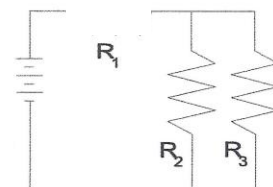

c) If bulb 2 were removed, leaving a gap, what would happen to the brightness of the remaining bulbs. Justify your answer.

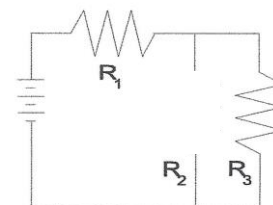

d) Imagine that the resistors in parallel (R_2 and R_3) were a single resistor. How would the combined equivalent resistance of R_{23} compare to the resistance of R_1 ?

e) Now let $R_1 = 10 \Omega$, $R_2 = 20 \Omega$, and $R_3 = 30 \Omega$. Fill out the table for the circuit

Circuit Position	Voltage (V)	Current (A)	Resistance (Ω)	Power (W)
1			10.0	
2			20.0	
3			30.0	
Total	6.00			

Questions 6 and 7 refer to the following:

The diagram below represents an electric circuit consisting of four resistors and a 12-volt battery.

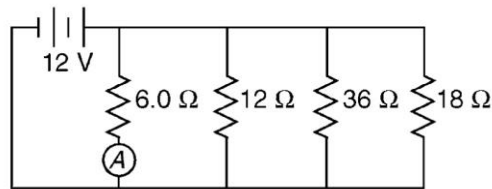

6) What is the equivalent resistance of the circuit shown?

7) What is the current measured by ammeter A shown in the diagram?

8) A 6.0-ohm lamp requires 0.25 ampere of current to operate. In which circuit below would the lamp operate correctly when switch S is closed?

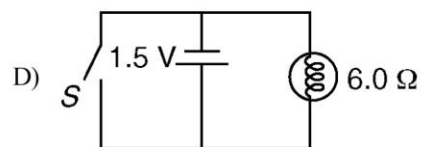
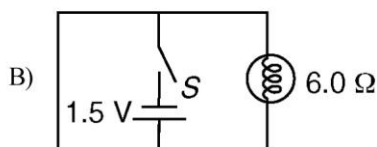
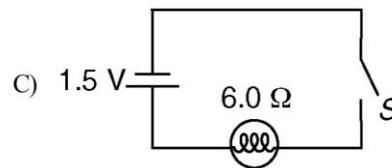
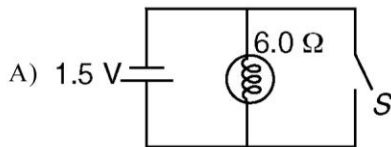

Questions 9 and 10 refer to the following:

A 50.-ohm resistor, an unknown resistor R , a 120-volt source, and an ammeter are connected in a complete circuit. The ammeter reads 0.50 ampere.

9) Calculate the equivalent resistance of the circuit shown.

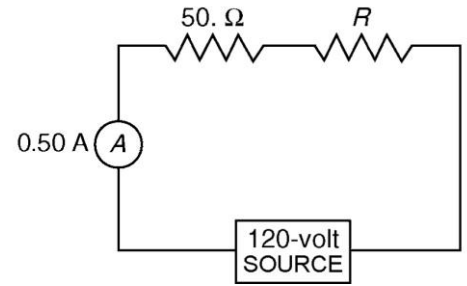

10) Determine the resistance of resistor R shown in the diagram.

Questions 11 through 13 refer to the following:

A 3.0-ohm resistor, an unknown resistor, R , and two ammeters, A_1 and A_2 , are connected as shown at right with a 12-volt source. Ammeter A_2 reads a current of 5.0 amperes.

11) Determine the equivalent resistance of the circuit shown.

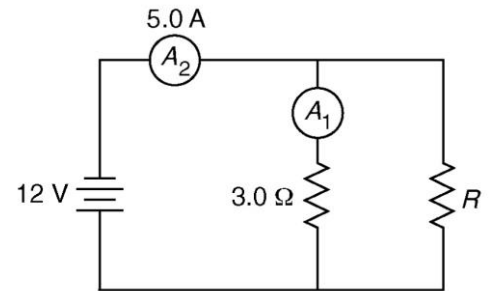

12) Calculate the current measured by ammeter A_1 in the diagram shown.

13) Calculate the resistance of the unknown resistor, R in the diagram shown.

14. A 110-V household circuit that contains an 1800-W microwave, a 1000-W toaster, and an 800-W coffeemaker is connected to a 20-A fuse. Determine the current. Will the fuse melt if the microwave and the coffeemaker are both on? Justify your answer.

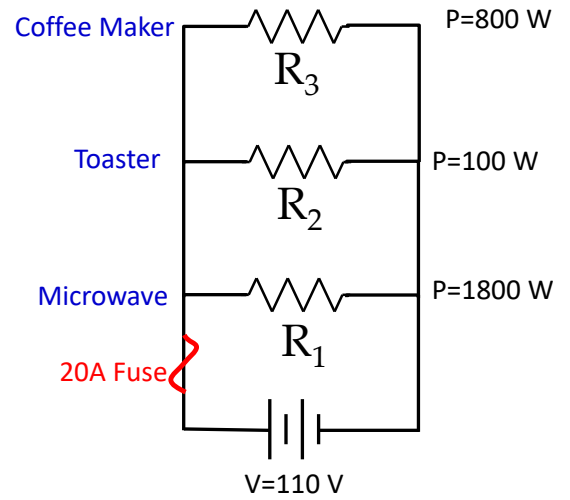

15. Determine the equivalent resistance of two resistors of $12\ \Omega$ and $18\ \Omega$ when they are connected
- in parallel

b) in series

- 16) Assume that you have five one thousand ohm ($1000\ \Omega$) resistors.

a) Devise a circuit with an equivalent resistance of 1333 ohms.

b) Devise a circuit with an equivalent resistance of 750 ohm

c) Using all five resistors, what is the smallest resistance that can be constructed?

d) Using all five resistors, what is the largest resistance that can be constructed?

17. (CHALLENGE QUESTION) Given the circuit at right:

a) Draw the current flow on the circuit. Label each current

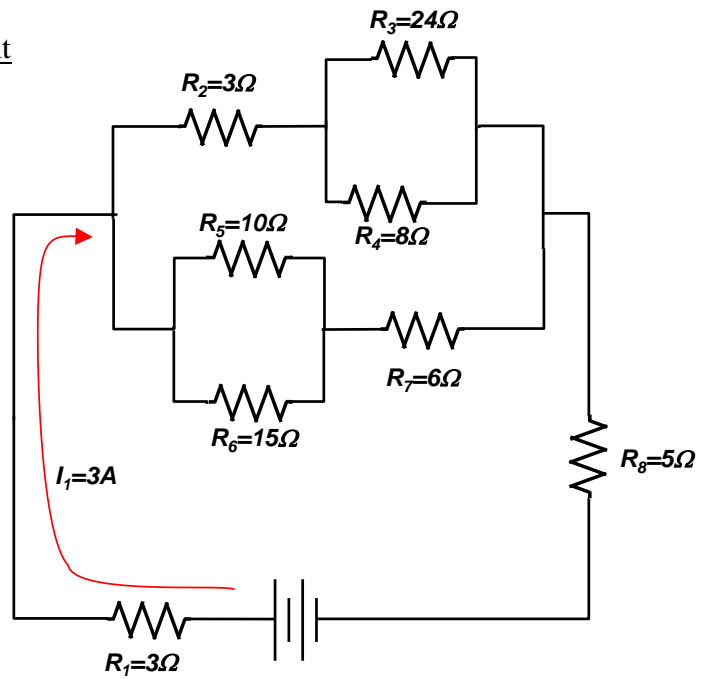

b) Find the equivalent resistance, R_{eq} , of the circuit

c) Complete the table

	ΔV (v)	I (A)	R (Ω)	P (W)
1		3	3	
2			3	
3			24	
4			8	
5			10	
6			15	
7			6	
8			5	
Total				

Answers

1a) 1.2Ω

1b) 7Ω

1c) 14Ω

2a) 13 V

2b) 12 V

5a) $I_2 = I_3 < I_1$

b) $R_1/2$

6) 3.0Ω

7) 2.0 A

8) C

9) 240Ω

10) 190Ω

11) 2.4Ω

12) 4.0 A

13) 12Ω

14) 23.7 A

15a) 7.2Ω

b) 30Ω

16c) 200Ω

d) 5000Ω

17b) $R_{eq} = 13.14 \Omega$