



**This product has been
discontinued**

Spec Sheet

Cisco UCS B230 M2 Blade Server

CISCO SYSTEMS
170 WEST TASMAN DR.
SAN JOSE, CA, 95134
WWW.CISCO.COM

PUBLICATION HISTORY

REV A.21 MAY 9, 2015

OVERVIEW	3
DETAILED VIEWS	4
Chassis Front View	4
BASE SERVER STANDARD CAPABILITIES and FEATURES	5
CONFIGURING the SERVER	6
STEP 1 VERIFY BASE SKU	7
STEP 2 CHOOSE CPU(S)	8
STEP 3 CHOOSE MEMORY	9
STEP 4 CHOOSE SOLID STATE DRIVES	13
STEP 5 CHOOSE MEZZANINE OPTION CARD	14
STEP 6 CHOOSE OPERATING SYSTEM AND VALUE-ADDED SOFTWARE	15
STEP 7 CHOOSE OPERATING SYSTEM MEDIA KIT	18
STEP 8 CHOOSE SERVICE and SUPPORT LEVEL	19
ORDER OPTIONAL KVM CABLE	24
SUPPLEMENTAL MATERIAL	25
Motherboard	25
DIMM and CPU Layout	26
Memory Population Recommendations	27
TECHNICAL SPECIFICATIONS	29
Dimensions and Weight	29
Power Specifications	29

OVERVIEW

The Cisco® UCS B230 M2 Blade Server is a two-socket, half-width blade server that extends the capabilities of the Cisco Unified Computing System™, using Intel's Xeon E7-2800 and E7-8800 Series multi-core processors with 32 DIMM slots, one mezzanine slot, and up to two solid-state drives (SSDs). Up to eight half-width blade servers can be accommodated in the Cisco UCS 5108 Blade Server Chassis. The UCS B230 M2 server is shown in [Figure 1](#).

Figure 1 Cisco UCS B230 M2 Blade Server



DETAILED VIEWS

Chassis Front View

Figure 2 shows the front of the Cisco UCS B230 M2 Blade Server.

Figure 2 Chassis Front View

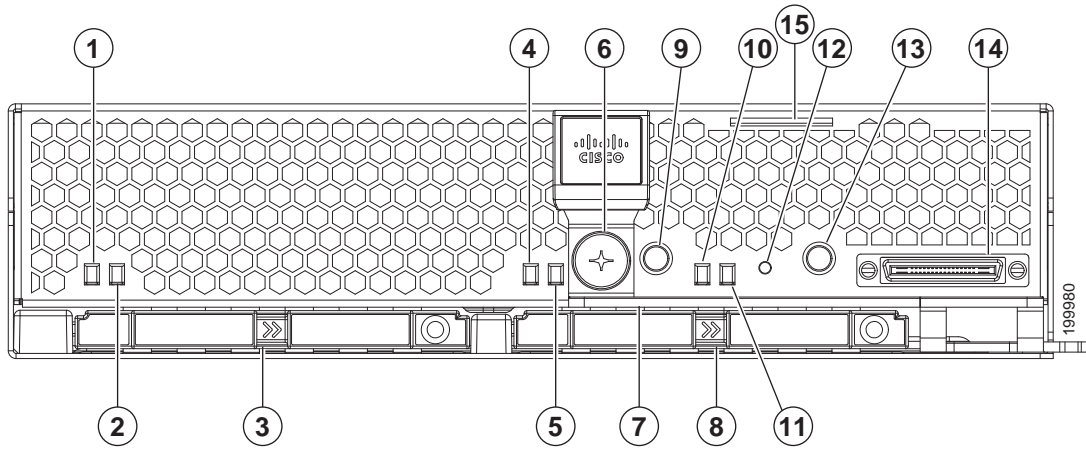

1	SSD 1 activity LED	9	Beaoning LED and button
2	SSD 1 Fault/Locate LED	10	System activity LED
3	SSD sled in bay 1	11	Blade health LED
4	SSD 2 activity LED	12	Reset button access
5	SSD 2 fault LED	13	Power button and LED
6	Ejector lever captive screw	14	Console connector ¹
7	Ejector lever	15	Asset tab ²
8	SSD sled in bay 2	-	-

Notes . . .

1. For more information regarding the KVM cable connection, see [ORDER OPTIONAL KVM CABLE on page 24](#)
2. Each server has a blank plastic tag that pulls out of the front panel, provided so you can add your own asset tracking label without interfering with the intended air flow

BASE SERVER STANDARD CAPABILITIES and FEATURES

Table 1 lists the capabilities and features of the base server. Details about how to configure the server for a particular feature or capability (for example, number of processors, disk drives, or amount of memory) are provided in *CONFIGURING the SERVER on page 6*.

Table 1 Capabilities and Features

Capability/Feature	Description
Chassis	The B230 M2 Blade Server mounts in a Cisco UCS 5100-series chassis
CPU	Either 1 or 2 Intel® Xeon® E7-2800 or E7-8800 series processors
Chipset	Intel® 7510 chipset
Memory	32 slots for registered DIMMs, up to 512 GB.
Expansion slots	One mezzanine slot is provided
Storage controller	LSI SAS 2008 RAID controller (onboard version of LSI MegaRAID 9240)
Internal storage devices	Up to two optional front-accessible, hot-swappable low-height 7 mm form factor SATA solid-state disk drives (SSDs).
Video	The server CIMC chip includes a Matrox G200 core. The first 8 MB of memory are allocated to the video core.
Interfaces	One front-accessible console connector (see <i>ORDER OPTIONAL KVM CABLE on page 24</i>)
Power subsystem	Integrated in the Cisco UCS 5100 series chassis
Fans	Integrated in the Cisco UCS 5100 series chassis
Integrated management processor	The built-in Cisco Integrated Management Controller (CIMC) GUI or CLI interface enables you to monitor the server inventory, health, and system event logs.
Cisco UCS Diagnostics for Cisco UCS B-Series Blade Servers	<p>The Cisco UCS Blade Server Diagnostics tool for Cisco UCS Blade Servers enables you to verify the health of the hardware components on your servers. The diagnostics tool provides a variety of tests to exercise and stress the various hardware subsystems on the Cisco UCS Blade Servers, such as memory and CPU. You can use the tool to run a sanity check on the state of your Cisco UCS Blade Servers after you fix or replace a hardware component. You can also use this tool to run comprehensive burn-in tests before you deploy a new Cisco UCS Blade Server in your production environment.</p> <p>See the following links for more information:</p> <p>User Guide: http://www.cisco.com/c/en/us/td/docs/unified_computing/ucs/sw/ucs_diagnostics/b_UCS_Blade_Server_Diagnostics_User_Guide.html</p> <p>ISO Download: http://www.cisco.com/cisco/software/navigator.html</p>

CONFIGURING the SERVER

Follow these steps to configure the Cisco UCS B230 M2 Server:

- *STEP 1 VERIFY BASE SKU, page 7*
- *STEP 2 CHOOSE CPU(S), page 8*
- *STEP 3 CHOOSE MEMORY, page 9*
- *STEP 4 CHOOSE SOLID STATE DRIVES, page 13*
- *STEP 5 CHOOSE MEZZANINE OPTION CARD, page 14*
- *STEP 6 CHOOSE OPERATING SYSTEM AND VALUE-ADDED SOFTWARE, page 15*
- *STEP 7 CHOOSE OPERATING SYSTEM MEDIA KIT, page 18*
- *STEP 8 CHOOSE SERVICE and SUPPORT LEVEL, page 19*

STEP 1 VERIFY BASE SKU

Verify the product ID (PID) of the base server as shown in [Table 2](#).

Table 2 PID of the Base B230 M2 Server

Product ID (PID)	Description
B230-BASE-M2	UCS B230 M2 Blade Server w/o CPU, memory, SSD, mezzanine

The B230-BASE-M2 base server:

- Does not include CPUs, memory DIMMs, solid-state Drives (SSDs), or a mezzanine card.



NOTE: Use the steps on the following pages to configure the server with the components that you want to include.

STEP 2 CHOOSE CPU(S)

The standard CPU features are:

- Intel Xeon E7-2800 or E7-8800 series CPUs
- Intel 7510 chipset
- Cache size of 18, 24, or 30 MB

Choose CPUs

The available CPUs are listed in [Table 3](#).

Table 3 Available CPUs: Intel Xeon E7-28xx/8867L Family

Product ID (PID)	Intel Number	Clock Freq (GHz)	Power (W)	Cache Size (MB)	Cores	QPI	Highest DDR3 DIMM Clock Support (MHz)
UCS-CPU-E78867L	E7-8867L	2.13	105	30	10	6.40	1333 ¹
UCS-CPU-E72870	E7-2870	2.40	130	30	10	6.40	1333 ¹
UCS-CPU-E72860	E7-2860	2.26	130	24	10	6.40	1333 ¹
UCS-CPU-E72850	E7-2850	2.00	130	24	10	6.40	1333 ¹
UCS-CPU-E27830	E7-2830	2.13	105	24	8	6.40	1333 ¹
UCS-CPU-E72803	E7-2803	1.73	105	18	6	4.80	1333 ²

Notes . . .

1. Maximum operational speed = 1066 MHz
2. Maximum operational speed = 800 MHz

Approved Configurations

(1) One-CPU Configuration

- Choose one CPU from [Table 3](#).

(2) Two-CPU Configuration

- Choose two CPUs from any one row of [Table 3](#).

Caveats

- You must choose one processor or two identical processors.

STEP 3 CHOOSE MEMORY

The standard memory features are:

- DIMMs
 - Maximum memory bandwidth: 800 MHz for E7-2803, 1066 MHz for all other CPUs
 - Ranks per DIMM: 1, 2, or 4
 - Operational voltage: 1.35 V
 - Registered DIMMs (RDIMMs)
 - Mirroring option
 - Advanced error correcting code (ECC)
 - Double device data correction (DDDC)



NOTE: DDDC support applies to x4 DIMMs only.

- Each CPU controls four DDR3 channels. Each of the channels controls four DIMMs. The maximum number of DIMMs that can be installed per CPU is 16 (8 DIMM kits). See [Figure 3](#).



NOTE: Memory mirroring is supported and settable using the UCSM Service Profile “Memory RAS Configuration” setting.

Figure 3 B230 M2 Memory Organization

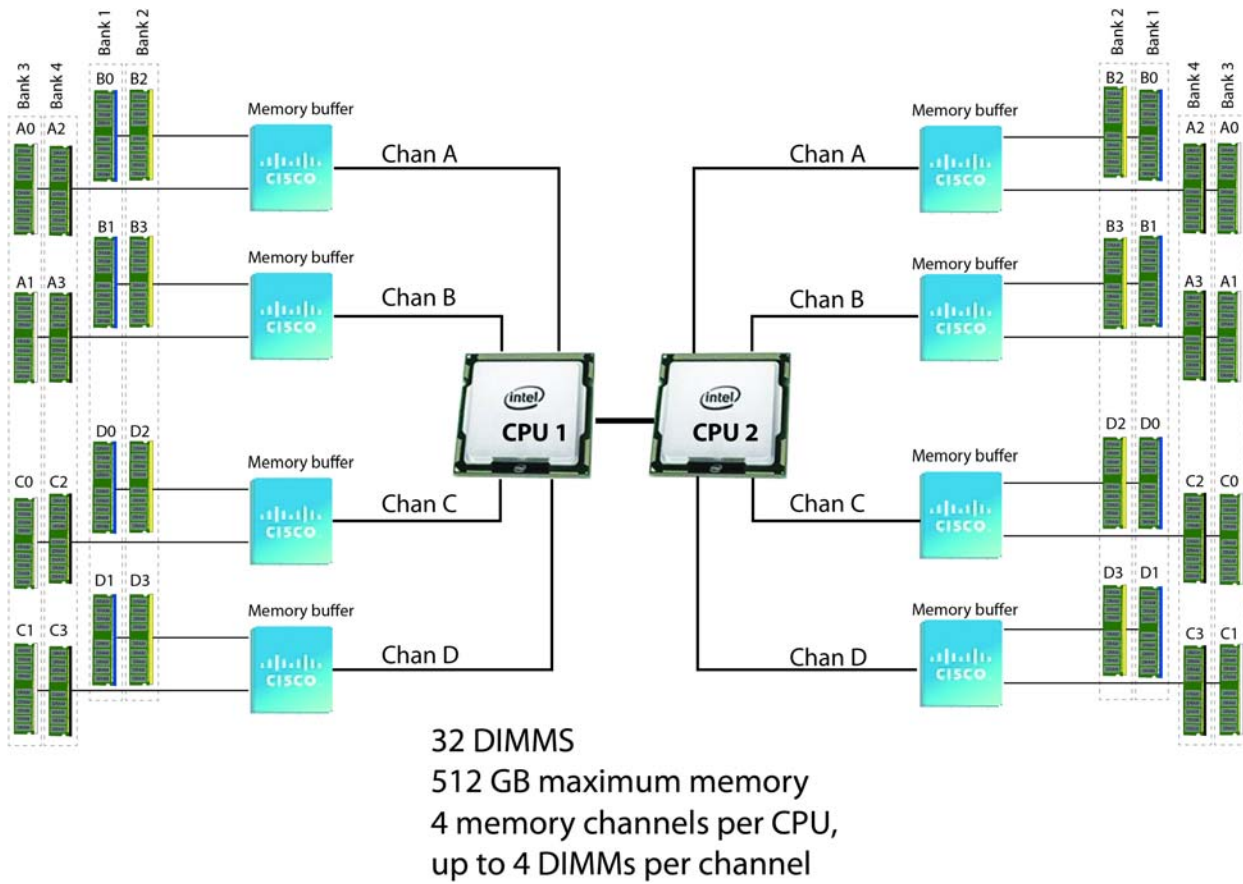

Select DIMMs

DIMMs are available as two-DIMM kits. Each of the product IDs in [Table 4](#) specifies two DIMMs.

Table 4 Available DDR3 DIMMs

Product ID (PID)	PID Description	Voltage	Ranks/ DIMM
DIMM Pair Kit Options (2 DIMMs per kit)			
UCS-MR-2X041RX-C	2x4GB DDR3-1333-MHz RDIMM/PC3-10600/1R/x4/1.35v	1.5/1.35 V	1
UCS-MR-2X082RX-C	2x8GB DDR3-1333-MHz RDIMM/PC3-10600/2R/x4/1.35v	1.5/1.35 V	2
UCS-MR-2x162RX-C	2x16GB DDR3-1333-MHz RDIMM/PC3-10600/2R/x4/1.35v	1.5/1.35 V	2

Approved Configurations

(1) 1-CPU Configuration

- 16 DIMMs capacity total
- Select either four or eight DIMM kits (eight or 16 DIMMs) per CPU. The DIMMs will be placed by the factory as shown in the following table:

Table 5 1-CPU Configuration DIMM Placement

Number of DIMMs	DIMM Placement in Numbered/Colored DIMM Slots (see Figure 7 on page 27)
8 ¹	(B0, B1) - (D0, D1) - blue slots; (A0, A1) - (C0, C1) - white slots
16 ²	(B0, B1) - (D0, D1) - blue slots; (A0, A1) - (C0, C1) - white slots (B2, B3) - (D2, D3) - yellow slots; (A2, A3) - (C2, C3) - black slots

Notes . . .

1. Four UCS-MR-2X041RX-C or UCS-MR-2X082RX-C or UCS-MR-2X162RX-C DIMM kits
2. Eight UCS-MR-2X041RX-C or UCS-MR-2X082RX-C or UCS-MR-2X162RX-C DIMM kits or a combination of four UCS-MR-2X082RX-C DIMM kits and four UCS-MR-2X162RX-C DIMM kits

(2) 2-CPU Configuration

- 32 DIMMs capacity total
- Select either four or eight DIMM kits (eight to 16 DIMMs) per CPU. The DIMMs will be placed by the factory as shown in the following table:

Table 6 2-CPU Configuration DIMM Placement

Number of DIMMs per CPU	DIMM Placement in Numbered/Colored DIMM Slots (see Figure 7 on page 27)
8 ¹	CPU 1: (B0, B1) - (D0, D1) - blue slots; (A0, A1) - (C0, C1) - white slots CPU 2: (B0, B1) - (D0, D1) - blue slots; (A0, A1) - (C0, C1) - white slots
16 ²	CPU 1: (B0, B1) - (D0, D1) - blue slots; (A0, A1) - (C0, C1) - white slots (B2, B3) - (D2, D3) - yellow slots; (A2, A3) - (C2, C3) - black slots CPU 2: (B0, B1) - (D0, D1) - blue slots; (A0, A1) - (C0, C1) - white slots (B2, B3) - (D2, D3) - yellow slots; (A2, A3) - (C2, C3) - black slots

Notes . . .

1. Four UCS-MR-2X041RX-C or UCS-MR-2X082RX-C or UCS-MR-2X162RX-C DIMM kits per CPU
2. Eight UCS-MR-2X041RX-C or UCS-MR-2X082RX-C or UCS-MR-2X162RX-C DIMM kits per CPU or a combination of four UCS-MR-2X082RX-C DIMM kits and four UCS-MR-2X162RX-C DIMM kits per CPU

Caveats

- The only supported DIMM configurations are shown in [Table 5 on page 11](#) and [Table 6 on page 11](#). The DIMMs are sold in matched pairs, which must be installed in pairs shown in the tables. Switching out one of the DIMMs within the matched pair will lead to memory errors.
- DIMMs sold as kits are matched pairs and must remain together when installed in a particular pair of same-colored (blue, white, yellow, or black) pairs of slots.
- The B230 M2 server needs at least four DIMM pairs installed for each CPU for optimal performance.
- The DIMMs installed in slots for an absent CPU are not recognized.

STEP 4 CHOOSE SOLID STATE DRIVES

The standard disk drive features are:

- 7 mm low-height form factor solid state drives
- Hot-pluggable
- Sled-mounted

Choose Drives

The available drives are listed in [Table 7](#).

Table 7 Available Hot-Pluggable Sled-Mounted SSDs

Product ID (PID)	PID Description	Drive Type	Capacity
UCS-SD300G0KA2-T	300 GB SATA 7 mm Enterprise Performance SSD	SATA	300 GB
UCS-SD200G0KA2-T	200 GB SATA 7 mm Enterprise Performance SSD	SATA	200 GB
UCS-SSD100GI1F105	100 GB SATA 7 mm Enterprise Performance SSD	SATA	100 GB
UCS-SD400G0KA2-S	400 GB SATA 7 mm Enterprise Value SSD	SATA	400 GB
UCS-SD100G0KA2-S	100 GB SATA 7 mm Enterprise Value SSD	SATA	100 GB

Approved Configurations

(1) 1-Drive Configuration

- Select one drive from [Table 7](#).

(2) 2-Drive Configuration

- Select two drives from [Table 7](#).

Caveats

- None

STEP 5 CHOOSE MEZZANINE OPTION CARD

The standard PCIe card offerings are:

- Converged Network Adapters (CNA)
- Network Interface Cards (NICs)

Choose a PCIe Option Card

The available PCIe option cards are listed in [Table 8](#).

Table 8 Available PCIe Option Cards

Product ID (PID)	PID Description
Converged Network Adapters (CNA)	
UCSB-MEZ-QLG-03 ¹	Cisco UCS CNA M73KR-Q Qlogic Adapter
UCS-VIC-M82-8P	Cisco UCS VIC 1280 dual 40Gb capable Virtual Interface Card
N20-AC0002 ²	UCS M81KR Virtual Interface Card/PCIe/2-port 10Gb

Notes . . .

1. This new M73KR-Q adapter is the nearest equivalent replacement for the obsolete M72KR-Q adapter.
2. The UCS M81KR VIC is no longer orderable.

Approved Configurations

(1) Select one PCIe Mezzanine Card (mandatory)

You must select one card.

To help ensure that your operating system is compatible with the card you have selected, please check the Hardware Compatibility List at this URL:

http://www.cisco.com/en/US/products/ps10477/prod_technical_reference_list.html

STEP 6 CHOOSE OPERATING SYSTEM AND VALUE-ADDED SOFTWARE

Several operating systems and value-added software programs are available. Select as desired from [Table 9](#).

Table 9 OSs and Value-Added Software (for 2-CPU servers)

PID Description	Product ID (PID)
Microsoft Windows Server	
MSWS-12-ST2S	Windows Server 2012 Standard (2 CPU/2 VMs)
MSWS-12-DC2S	Windows Server 2012 Datacenter (2 CPU/Unlimited VMs)
MSWS-12-ST2S-NS	Windows Server 2012 Standard (2 CPU/2 VMs) No Cisco SVC
MSWS-12-DC2S-NS	Windows Server 2012 Datacenter (2 CPU/Unlim VM) No Cisco SVC
MSWS-12R2-ST2S	Windows Server 2012 R2 Standard (2 CPU/2 VMs)
MSWS-12R2-DC2S	Windows Server 2012 R2 Datacenter (2 CPU/Unlimited VMs)
MSWS-12R2-ST2S-NS	Windows Server 2012 R2 Standard (2 CPU/2 VMs) No Cisco SVC
MSWS-12R2-DC2S-NS	Windows Server 2012 R2 Datacen (2 CPU/Unlim VM) No Cisco Svc
SUSE	
SLES-SVR-2S-1G-1A	SUSE Linux Enterprise Svr (1-2 CPU,1 Phys);1yr Support Reqd
SLES-SVR-2S-1G-3A	SUSE Linux Enterprise Svr (1-2 CPU,1 Phys);3yr Support Reqd
SLES-SVR-2S-1G-5A	SUSE Linux Enterprise Svr (1-2 CPU,1 Phys);5yr Support Reqd
SLES-SVR-2S-UG-1A	SUSE Linux Enterprise Svr (1-2 CPU,Unl Vrt);1yr Support Reqd
SLES-SVR-2S-UG-3A	SUSE Linux Enterprise Svr (1-2 CPU,Unl Vrt);3yr Support Reqd
SLES-SVR-2S-UG-5A	SUSE Linux Enterprise Svr (1-2 CPU,Unl Vrt);5yr Support Reqd
SLES-SHA-2S-1A	SUSE Linux High Availability Ext (1-2 CPU); 1yr Support Reqd
SLES-SHA-2S-3A	SUSE Linux High Availability Ext (1-2 CPU); 3yr Support Reqd
SLES-SHA-2S-5A	SUSE Linux High Availability Ext (1-2 CPU); 5yr Support Reqd
SLES-HGC-2S-1A	SUSE Linux GEO Clustering for HA (1-2 CPU); 1yr Support Reqd
SLES-HGC-2S-3A	SUSE Linux GEO Clustering for HA (1-2 CPU); 3yr Support Reqd
SLES-HGC-2S-5A	SUSE Linux GEO Clustering for HA (1-2 CPU); 5yr Support Reqd
SLES-SAP-2S-1G-1A	SLES for SAP Applications (1-2 CPU,1 Phys); 1yr Support Reqd
SLES-SAP-2S-1G-3A	SLES for SAP Applications (1-2 CPU,1 Phys); 3yr Support Reqd
SLES-SAP-2S-1G-5A	SLES for SAP Applications (1-2 CPU,1 Phys); 5yr Support Reqd
SLES-SAP-2S-UG-1A	SLES for SAP Applications (1-2 CPU,Unl Vrt);1yr Support Reqd
SLES-SAP-2S-UG-3A	SLES for SAP Applications (1-2 CPU,Unl Vrt);3yr Support Reqd
SLES-SAP-2S-UG-5A	SLES for SAP Applications (1-2 CPU,Unl Vrt);5yr Support Reqd

Table 9 OSs and Value-Added Software (for 2-CPU servers) (continued)

PID Description	Product ID (PID)
Red Hat Enterprise Linux	
RHEL-2S-1G-1A	RHEL/2 Socket/1 Guest/1Yr Svcs Required
RHEL-2S-1G-3A	RHEL/2 Socket/1 Guest/3Yr Svcs Required
RHEL-HA-2S-1A	RHEL Option/High-Availability/2 Socket/1Yr Svcs Required
RHEL-HA-2S-3A	RHEL Option/High-Availability/2 Socket/3Yr Svcs Required
RHEL-RS-2S-1A	RHEL Option/Resilient w/Ha /2 Socket/1 Yr Svcs Required
RHEL-RS-2S-3A	RHEL Option/Resilient Storage w/ HA /2 Socket/3 Yr Svcs Reqd
RHEL-SFS-2S-1A	RHEL Option/Scalable File System/2 Socket/1 Yr Svcs Required
RHEL-SFS-2S-3A	RHEL Option/Scalable File System/2 Socket/1 Yr Svcs Required
Nexus 1000V for Hyper-V and vSphere	
N1K-VSG-UCS-BUN	Over half off N1K and VSG w/ purchase of UCS B/C Series
N1K-VLEM-UCS-1	Nexus 1000V License Paper Delivery (1 CPU) for bundles
VSG-VLEM-UCS-1	VSG License Paper Delivery (1 CPU) for bundles
UCS Director	
CUIC-PHY-SERV-BM-U	Cisco Cloupia Resource Lic - One Phy Server node bare metal
CUIC-PHY-SERV-U	Cisco Cloupia Resource Lic - One physical Server node
CUIC-TERM	Acceptance of Cisco Cloupia License Terms
UCS Performance Manager	
UCS-PM-IE	UCS Performance Manager
UCS-PM-EE	UCS Performance Manager Express
EVAL-UCS-PM-IE	UCS Performance Manager - 60 days evaluation
EVAL-UCS-PM-EE	UCS Performance Manager Express - 60 days evaluation
NFR-UCS-PM-IE	UCS Performance Manager - Not For Resale
NFR-UCS-PM-EE	CS Performance Manager Express - Not For Resale
IMC Supervisor	
EVAL-CIMC-SUP	EVAL: IMC Supervisor-Branch Mgt SW for C/E-Series - 50 Svrs
EVAL-CIMC-SUP-BAS	EVAL: IMC Supervisor One-time Site Installation License
CIMC-SUP-B01	IMC Supervisor-Branch Mgt SW for C-Series & E-Series up to 100 Svrs
CIMC-SUP-B02	IMC Supervisor- Branch Mgt SW for C-Series & E-Series up to 250 Svrs
CIMC-SUP-B10	IMC Supervisor- Branch Mgt SW for C-Series & E-Series up to 1K Svrs
CIMC-SUP-BASE-K9	IMC Supervisor One-time Site Installation License
CIMC-SUP-TERM	Acceptance of Cisco IMC Supervisor License Terms
VMware 5	
VMW-VS5-STD-1A	VMware vSphere 5 Standard for 1 Processor, 1 Year, Support Rqd
VMW-VS5-STD-2A	VMware vSphere 5 Standard for 1 Processor, 2 Year, Support Rqd
VMW-VS5-STD-3A	VMware vSphere 5 Standard for 1 Processor, 3 Year, Support Rqd
VMW-VS5-STD-4A	VMware vSphere 5 Standard for 1 Processor, 4 Year, Support Rqd
VMW-VS5-STD-5A	VMware vSphere 5 Standard for 1 Processor, 5 Year, Support Rqd

Table 9 OSs and Value-Added Software (for 2-CPU servers) (*continued*)

PID Description	Product ID (PID)
VMW-VS5-ENT-1A	VMware vSphere 5 Enterprise for 1 Processor, 1 Year Support Rqd
VMW-VS5-ENT-2A	VMware vSphere 5 Enterprise for 1 CPU, 2 Yr Support Rqd
VMW-VS5-ENT-3A	VMware vSphere 5 Enterprise for 1 CPU, 3 Yr Support Rqd
VMW-VS5-ENT-4A	VMware vSphere 5 Enterprise for 1 Processor, 4 Year Support Rqd
VMW-VS5-ENT-5A	VMware vSphere 5 Enterprise for 1 CPU, 5 Yr Support Rqd
VMW-VS5-ENTP-1A	VMware vSphere 5 Enterprise Plus for 1 Processor, 1 Year Support Rqd
VMW-VS5-ENTP-2A	VMware vSphere 5 Enterprise Plus for 1 CPU, 2 Yr Support Rqd
VMW-VS5-ENTP-3A	VMware vSphere 5 Enterprise Plus for 1 Processor, 3 Year Support Rqd
VMW-VS5-ENTP-4A	VMware vSphere 5 Enterprise Plus for 1 Processor, 4 Year Support Rqd
VMW-VC5-STD-1A	VMware vCenter 5 Server Standard, 1 yr support required
VMW-VC5-STD-2A	VMware vCenter 5 Server Standard, 2 yr support required
VMW-VC5-STD-3A	VMware vCenter 5 Server Standard, 3 yr support required
VMW-VC5-STD-4A	VMware vCenter 5 Server Standard, 4 yr support required
VMW-VC5-STD-5A	VMware vCenter 5 Server Standard, 5 yr support required

STEP 7 CHOOSE OPERATING SYSTEM MEDIA KIT

Choose the optional operating system media listed in [Table 10](#).

Table 10 OS Media

Product ID (PID)	PID Description
RHEL-6	RHEL 6 Recovery Media Only (Multilingual)
SLES-11	SLES 11 media only (multilingual)
MSWS-08R2-STHV-RM	Windows Svr 2008 R2 ST (1-4CPU, 5CAL), Media
MSWS-08RS-ENHV-RM	Windows Svr 2008 R2 EN (1-8CPU, 25CAL), Media
MSWS-08R2-DCHV-RM	Windows Svr 2008 R2 DC (1-8CPU, 25CAL), Media
MSWS-12-ST2S-RM	Windows Server 2012 Standard (2 CPU/2 VMs) Recovery Media
MSWS-12-DC2S-RM	Windows Server 2012 Datacenter (2 CPU/Unlimited VM) Rec Media
MSWS-12R2-ST2S-RM	Windows Server 2012 R2 Standard (2 CPU/2 VMs) Recovery Media
MSWS-12R2-DC2S-RM	Windows Server 2012 R2 Datacen(2 CPU/Unlimited VM) Rec Media

STEP 8 CHOOSE SERVICE and SUPPORT LEVEL

A variety of service options are available, as described in this section.

Unified Computing Warranty, No Contract

If you have noncritical implementations and choose to have no service contract, the following coverage is supplied:

- Three-year parts coverage.
- Next business day (NBD) onsite parts replacement eight hours a day, five days a week.
- 90-day software warranty on media.
- Ongoing downloads of BIOS, drivers, and firmware updates.
- UCSM updates for systems with Unified Computing System Manager. These updates include minor enhancements and bug fixes that are designed to maintain the compliance of UCSM with published specifications, release notes, and industry standards.

SMARTnet for UCS

For support of the entire Unified Computing System, Cisco offers the Cisco SMARTnet for UCS Service. This service provides expert software and hardware support to help sustain performance and high availability of the unified computing environment. Access to Cisco Technical Assistance Center (TAC) is provided around the clock, from anywhere in the world.

For UCS blade servers, there is Smart Call Home, which provides proactive, embedded diagnostics and real-time alerts. For systems that include Unified Computing System Manager, the support service includes downloads of UCSM upgrades. The Cisco SMARTnet for UCS includes flexible hardware replacement options, including replacement in as little as two hours. There is also access to Cisco's extensive online technical resources to help maintain optimal efficiency and uptime of the unified computing environment. You can choose a desired service listed in [Table 11](#).

Table 11 Cisco SMARTnet for UCS Service

Product ID (PID)	On Site?	Description
CON-PREM-B230M2	Yes	ONSITE 24X7X2 B230 M2 Blade Server
CON-OSP-B230M2	Yes	ONSITE 24X7X4 B230 M2 Blade Server
CON-OSE-B230M2	Yes	ONSITE 8X5X4 B230 M2 Blade Server
CON-OS-B230M2	Yes	ONSITE 8X5XNBD B230 M2 Blade Server
CON-S2P-B230M2	No	SMARTNET 24X7X2 B230 M2 Blade Server
CON-SNTP-B230M2	No	SMARTNET 24X7X4 B230 M2 Blade Server
CON-SNTE-B230M2	No	SMARTNET 8X5X4 B230 M2 Blade Server
CON-SNT-B230M2	No	SMARTNET 8X5XNBD B230 M2 Blade Server

SMARTnet for UCS Hardware Only Service

For faster parts replacement than is provided with the standard Cisco Unified Computing System warranty, Cisco offers the Cisco SMARTnet for UCS Hardware Only Service. You can choose from two levels of advanced onsite parts replacement coverage in as little as four hours. SMARTnet for UCS Hardware Only Service provides remote access any time to Cisco support professionals who can determine if a return materials authorization (RMA) is required. You can choose a service listed in [Table 12](#).

Table 12 SMARTnet for UCS Hardware Only Service

Product ID (PID)	Service Level GSP	On Site?	Description
CON-UCW7-B230M2	UCW7	Yes	UC PLUS 24X7X4OS B230 M2 Blade Server
CON-UCW5-B230M2	UCW5	Yes	UC PLUS 8X5XNBDOS B230 M2 Blade Server

Unified Computing Partner Support Service

Cisco Partner Support Service (PSS) is a Cisco Collaborative Services service offering that is designed for partners to deliver their own branded support and managed services to enterprise customers. Cisco PSS provides partners with access to Cisco's support infrastructure and assets to help them:

- Expand their service portfolios to support the most complex network environments
- Lower delivery costs
- Deliver services that increase customer loyalty

Partner Unified Computing Support Options enable eligible Cisco partners to develop and consistently deliver high-value technical support that capitalizes on Cisco intellectual assets. This helps partners to realize higher margins and expand their practice.

PSS is available to all Cisco PSS partners, but requires additional specializations and requirements. For additional information, see the following URL:

www.cisco.com/go/partnerucssupport

The two Partner Unified Computing Support Options include:

- Partner Support Service for UCS
- Partner Support Service for UCS Hardware Only

Partner Support Service for UCS provides hardware and software support, including triage support for third party software, backed by Cisco technical resources and level three support.

See [Table 13](#).

Table 13 Partner Support Service for UCS

Product ID (PID)	Service Level GSP	On Site?	Description
CON-PSJ1-B230M2	PSJ1	No	UCS SUPP PSS 8X5XNBD B230 M2 Blade Server
CON-PSJ2-B230M2	PSJ2	No	UCS SUPP PSS 8X5X4 B230 M2 Blade Server
CON-PSJ3-B230M2	PSJ3	No	UCS SUPP PSS 24X7X4 B230 M2 Blade Server
CON-PSJ4-B230M2	PSJ4	No	UCS SUPP PSS 24X7X2 B230 M2 Blade Server

Partner Support Service for UCS Hardware Only provides customers with replacement parts in as little as two hours. See [Table 14](#).

Table 14 Partner Support Service for UCS (Hardware Only)

Product ID (PID)	Service Level GSP	On Site?	Description
CON-PSW2-B230M2	PSW2	No	UCS W PL PSS 8X5X4 B230 M2 Blade Server
CON-PSW3-B230M2	PSW3	No	UCS W PL PSS 24X7X4 B230 M2 Blade Server
CON-PSW4-B230M2	PSW4	No	UCS W PL PSS 24X7X2 B230 M2 Blade Server

Unified Computing Combined Support Service

Combined Services makes it easier to purchase and manage required services under one contract. SMARTnet services for UCS help increase the availability of your vital data center infrastructure and realize the most value from your unified computing investment. The more benefits you realize from the Cisco Unified Computing System (Cisco UCS), the more important the technology becomes to your business. These services allow you to:

- Optimize the uptime, performance, and efficiency of your UCS
- Protect your vital business applications by rapidly identifying and addressing issues
- Strengthen in-house expertise through knowledge transfer and mentoring
- Improve operational efficiency by allowing UCS experts to augment your internal staff resources
- Enhance business agility by diagnosing potential issues before they affect your operations

You can choose a service listed in [Table 15](#).

Table 15 UCS Computing Combined Support Service

Product ID (PID)	Service Level GSP	On Site?	Description
CON-NCF2-B230M2	NCF2	No	CMB SPT SVC 24X7X2 B230 M2 Blade Server
CON-NCF2P-B230M2	NCF2P	Yes	CMB SPT SVC 24X7X2OS B230 M2 Blade Server
CON-NCF4P-B230M2	NCF4P	Yes	CMB SPT SVC 24X7X4OS B230 M2 Blade Server
CON-NCF4S-B230M2	NCF4S	Yes	CMB SPT SVC 8X5X4OS B230 M2 Blade Server
CON-NCFC S-B230M2	NCFC S	Yes	CMB SPT SVC 8X5XNBDOS B230 M2 Blade Server
CON-NCFE-B230M2	NCFE	No	CMB SPT SVC 8X5X4 B230 M2 Blade Server
CON-NCFP-B230M2	NCFP	No	CMB SPT SVC 24X7X4 B230 M2 Blade Server
CON-NCFT-B230M2	NCFT	No	CMB SPT SVC 8X5XNBD B230 M2 Blade Server

Unified Computing Drive Retention Service

With the Cisco Unified Computing Drive Retention (UCDR) Service, you can obtain a new disk drive in exchange for a faulty drive without returning the faulty drive. In exchange for a Cisco replacement drive, you provide a signed Certificate of Destruction (CoD) confirming that the drive has been removed from the system listed, is no longer in service, and has been destroyed.

Sophisticated data recovery techniques have made classified, proprietary, and confidential information vulnerable, even on malfunctioning disk drives. The UCDR service enables you to retain your drives and ensures that the sensitive data on those drives is not compromised, which reduces the risk of any potential liabilities. This service also enables you to comply with regulatory, local, and federal requirements.

If your company has a need to control confidential, classified, sensitive, or proprietary data, you might want to consider one of the Drive Retention Services listed in [Table 16](#).



NOTE: Cisco does not offer a certified drive destruction service as part of this service.

Table 16 Drive Retention Service Options

Service Description	Service Program Name	Service Level GSP	Service Level	Product ID (PID)
SMARTnet for UCS Service with Drive Retention	UCS DR	UCSD7	24x7x4 Onsite	CON-UCSD7-B230M2
		UCSD7	8x5xNBD Onsite	CON-UCSD5-B230M2

Table 16 Drive Retention Service Options (*continued*)

Service Description	Service Program Name	Service Level GSP	Service Level	Product ID (PID)
SMARTnet for UCS HW ONLY+Drive Retention	UCS HW+DR	UCWD7	24x7x4 Onsite	CON-UCWD7-B230M2
		UCWD5	8x5xNBD Onsite	CON-UCWD5-B230M2

For more service and support information, see the following URL:

http://www.cisco.com/en/US/services/ps2961/ps10312/Unified_Computing_Services_Overview.pdf

For a complete listing of available services for Cisco Unified Computing System, see this URL:

http://www.cisco.com/en/US/products/ps10312/serv_group_home.html

ORDER OPTIONAL KVM CABLE

The KVM cable provides a connection into the server, providing a DB9 serial connector, a VGA connector for a monitor, and dual USB 2.0 ports for a keyboard and mouse. With this cable, you can create a direct connection to the operating system and the BIOS running on the server.

The KVM cable ordering information is listed in [Table 17](#).

Table 17 KVM Cable

Product ID (PID)	PID Description
37-1016-01	KVM Cable

Figure 4 KVM Cable

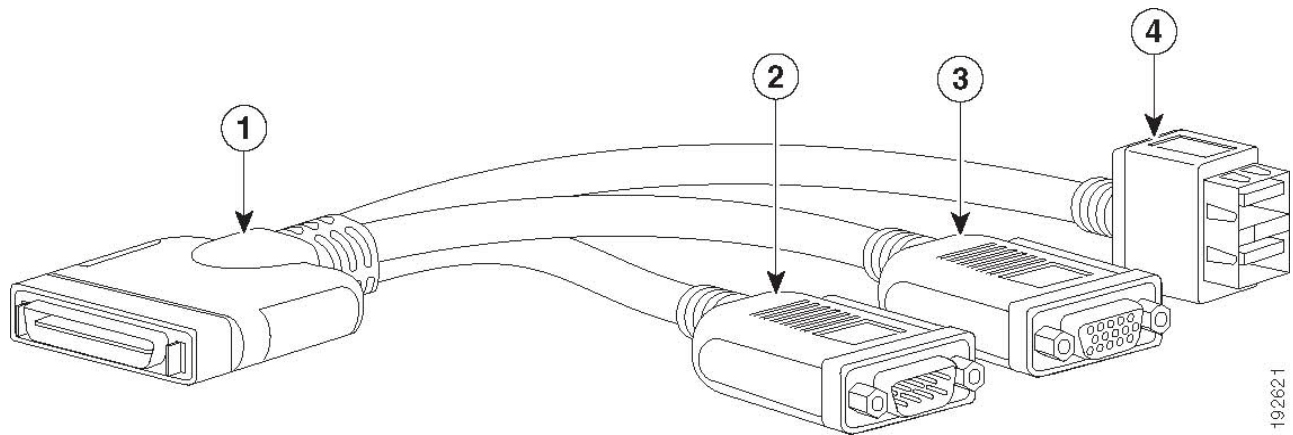

1	Connector (to server front panel)	3	VGA connector (for a monitor)
2	DB-9 serial connector	4	Two-port USB 2.0 connector (for a mouse and keyboard)

SUPPLEMENTAL MATERIAL

Motherboard

A top view of the B230 M2 motherboard is shown in *Figure 5*.

Figure 5 B230 M2 Motherboard

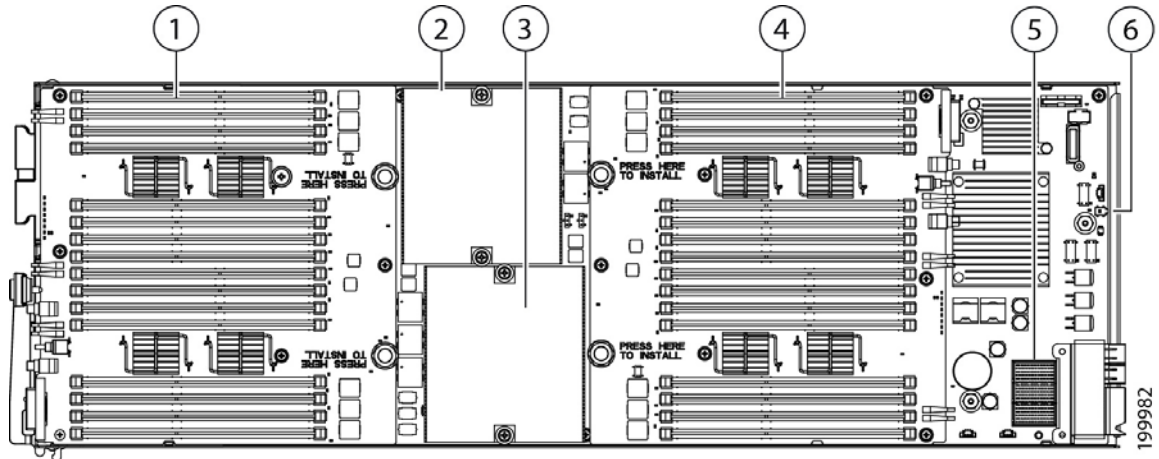

1	DIMM slots	4	DIMM slots
2	CPU 1 and heat sink	5	Mezzanine adapter card connector
3	CPU 2 and heat sink	6	Diagnostic button

DIMM and CPU Layout

Each CPU controls four memory channels, as shown in [Figure 6](#).

Figure 6 B230 M2 Memory Organization

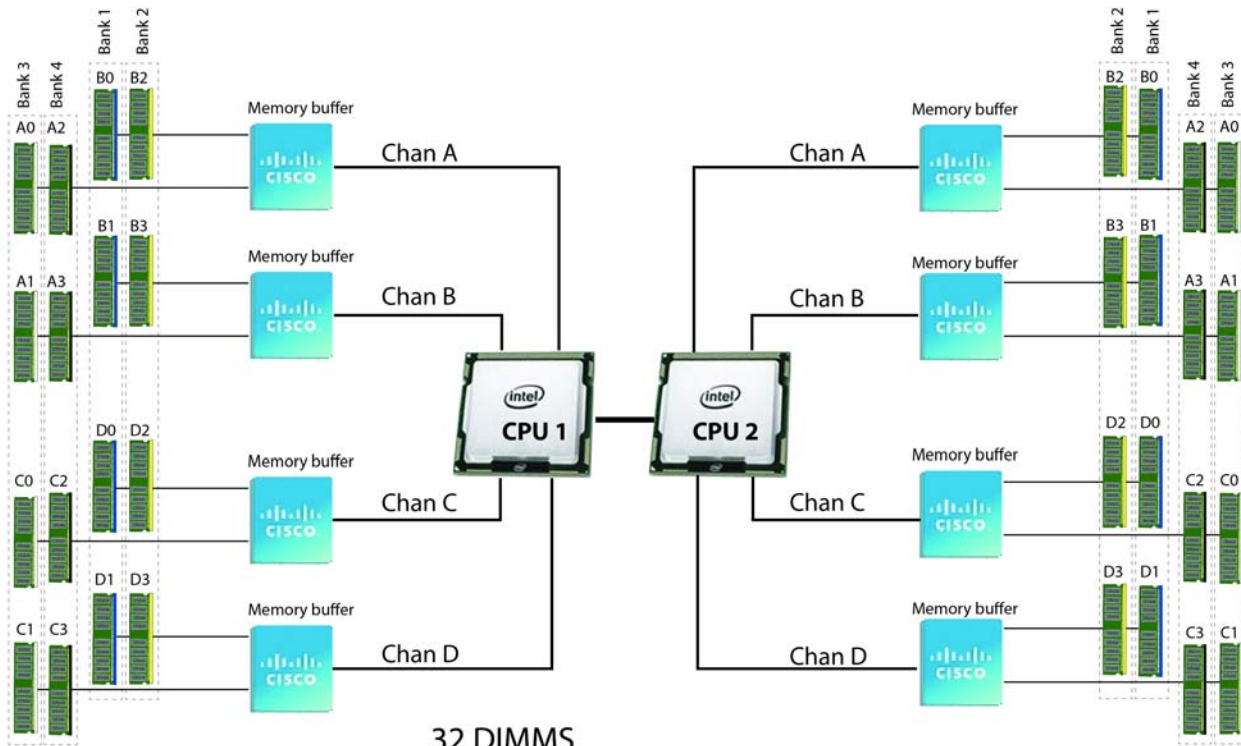

32 DIMMS
 512 GB maximum memory
 4 memory channels per CPU,
 up to 4 DIMMs per channel

- CPU1: Channels A, B, C, and D
 - Bank 1 - B0, B1; D0, D1 (blue DIMM slots)
 - Bank 2 - B2, B3; D2, D3 (yellow DIMM slots)
 - Bank 3 - A0, A1; C0, C1 (white DIMM slots)
 - Bank 4 - A2, A3; C2, C3 (black DIMM slots)
- CPU2: Channels A, B, C, and D
 - Bank 1 - B0, B1; D0, D1 (blue DIMM slots)
 - Bank 2 - B2, B3; D2, D3 (yellow DIMM slots)
 - Bank 3 - A0, A1; C0, C1 (white DIMM slots)
 - Bank 4 - A2, A3; C2, C3 (black DIMM slots)

The DIMM and CPU physical layout is shown in [Figure 7](#). CPU 1 is located on the upper half of the board and controls the upper DIMMs. CPU 2 is located on the lower half of the board and controls the lower DIMMs.

Figure 7 DIMM and CPU Layout

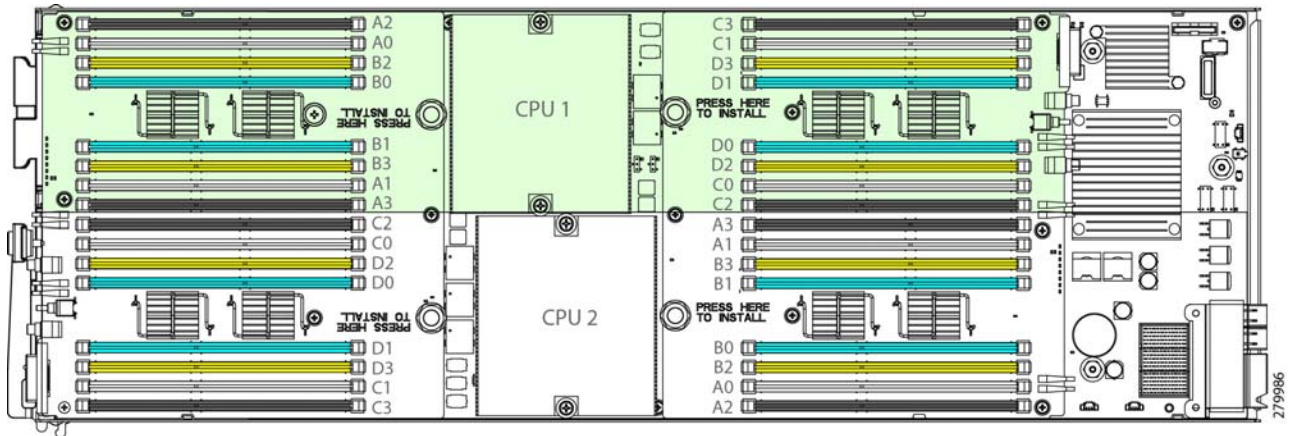

NOTE: DIMMs installed in slots for an absent CPU are not recognized.

Memory Population Recommendations

Table 18 shows the preferred order for installing upgrade DIMMs, and while other configurations may work, if problems arise, moving them to the preferred arrangement should help. Note that the bank installation order is Bank 1, Bank 3, Bank 2, Bank 4.

Table 18 Preferred DIMM Population Order

DIMMs per CPU	Numbered Slots ¹
8 (blue, white)	(B0, B1) - (D0, D1) - (A0, A1) - (C0, C1)
16 (blue, white, yellow, black)	(B0, B1) - (D0, D1) - (A0, A1) - (C0, C1) - (B2, B3) - (D2, D3) - (A2, A3) - (C2, C3)

Notes . . .

- The slots inside the parentheses are electrically paired with each other, and should be populated with identically matched DIMMs that were ordered as a pair. Do not swap a paired DIMM with a DIMM that is not identical in manufacturer part number.

When considering the memory configuration of your server, you should observe the following:

- DIMMs within the blade server can be of a different size.
- Your selected CPU(s) can have some effect on performance. If two CPUs are used, they must both be of the same type.
- Performance degradation can result from the following:
 - Mixing DIMM sizes and densities within a pair is not allowed and both DIMMs in the pair will be logically removed from the memory array
 - Unevenly populating DIMMs between CPUs
 - Populating channels with an odd number of total ranks (for example, mixing single-rank and dual-rank DIMMs)
 - Using anything other than 8 or 16 DIMMs per CPU properly placed in the system

TECHNICAL SPECIFICATIONS

Dimensions and Weight

Table 19 UCS B200 M2 Dimensions and Weight¹

Parameter	Value
Height	1.95 in. (50 mm)
Width	8.00 in. (203 mm)
Depth	24.4 in. (620 mm)
Weight	18.0 lbs (8.16 kg)*

Notes . . .

1. The system weight given here is an estimate for a fully configured system and will vary depending on the number of CPUs, memory DIMMs, and other optional items.

Power Specifications

For configuration-specific power specifications, use the Cisco UCS Power Calculator at:

<http://ucspowercalc.cisco.com>.



Americas Headquarters
Cisco Systems, Inc.
San Jose, CA

Asia Pacific Headquarters
Cisco Systems (USA) Pte. Ltd.
Singapore

Europe Headquarters
Cisco Systems International BV Amsterdam,
The Netherlands

Cisco has more than 200 offices worldwide. Addresses, phone numbers, and fax numbers are listed on the Cisco Website at www.cisco.com/go/offices.

Cisco and the Cisco Logo are trademarks of Cisco Systems, Inc. and/or its affiliates in the U.S. and other countries. A listing of Cisco's trademarks can be found at www.cisco.com/go/trademarks. Third party trademarks mentioned are the property of their respective owners. The use of the word partner does not imply a partnership relationship between Cisco and any other company. (1005R)