

INSTRUCTION

Handbook
ENG

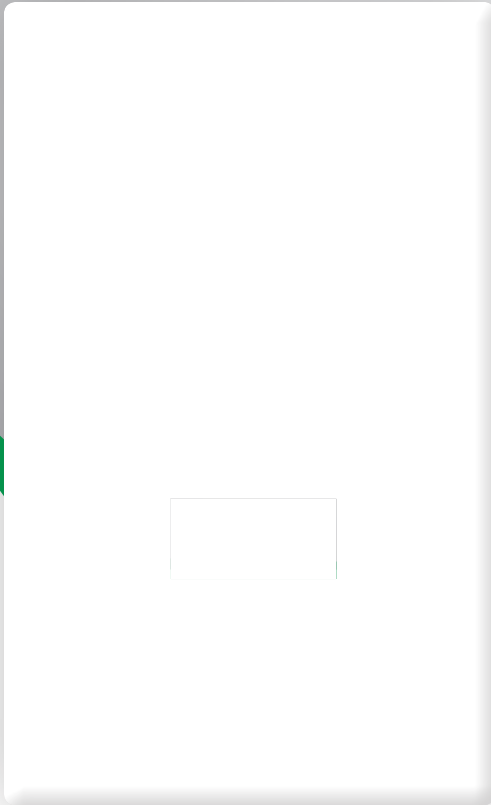

use
installation
adjustment
maintenance

CITY OPEN

25 K

35 K



IMPORTANT! Install the gasket included in the documents bag, on the intake/outlet flange, *as shown on page 21.*

Table of Content

Safety warnings 3

Safety warnings symbols legend	4
References to Laws and Norms	4
Personnel in charge of installation	4
Installation, use and maintenance	4
User warnings	5
Important	5
First starting up and Use	5
Installation, first starting up, maintenance and servicing	6
Appliance booklet or central plant booklet	6
Combustion checking	6
Boiler operation and servicing	6

User guide 7

Boiler controls	7
Remote control	7
Commands on the lower side	7
Commands outside the boiler	7
Service Control Panel	8
Typical use	8
Preliminary operations	8
Boiler use	8
Incidental malfunctioning	8
The burner doesn't turn on	9
Shortage of domestic hot water production	9
Boiler inactivity	9
Safety shut off	9
OFF mode with anti-frost & anti-locking function	10

Installation 11

Law and regulation prescriptions for the installer	11
Dimensions and connections	12
Pump capacity diagram	12
Warnings for the installation of optional kits or special systems	13
Floor heating system	13
Specifications for intake air	13
Domestic water supply characteristics	13
Protection against freezing	14
Outdoor installation in a partially protected place	14
Hydraulic system (DHW and heating)	16
Advices and suggestions to avoid vibrations and noises in the system	16
Cleaning and preservation of the systems	16
Heating system	16
Electric anti-freeze heaters	16
Condense drain	17
Heating system filling and pressuring	17

Gas connection	18
Electrical connections	19
Remote Control installation and connection	20
Flue systems	21
Intake/outlet flange	21
Installation of the flue intake/outlet flange gasket	21
General indications	21
Sizing C ₆₃ systems	22
Examples of installation of intake and outlet ducts	23
Sizing the flue system	24
Flue system length	24
How to use the tables	24
System length tables	25
Allowed flue types	26

Adjustment and Maintenance 27

First starting up	27
Maintenance operations	28
Access to the inside of the boiler	29
Venting the primary exchanger	30
Combustion group cleaning and check	30
PCB parameters settings (technician menu)	32
Main boiler parameters (PC)	32
Combustion test	36
Power adjustment tables	37
Max heating power adjustment	37
Combustion calibration	38
Accessing the main board	39
Main board replacement	39
Board configuration codes	39
Gas conversion	40
Draining the heating system	41
Pump settings	41
Alarms - boiler block	41
Warnings for servicing	48
ErP Data - EU 813/2013	49
Product fiche - EU 811/2013	49
Technical data	50
Boiler internal components	52
Electrical diagram	53
Hydraulic diagram	54

Addendum 55

Outdoor Sensor Kit	55
Installation and setting	55
The Service Control Panel	55
Boiler and Remote Control activation	57
Temperature adjustment (manual working modes)	58
Appliance disposal	59







This instructions manual is an essential and complementary part of the product and it is supplied together with the boiler.



Carefully read the manual, achieving all important information for a safe installation, use and servicing.

- ▶ **Carefully keep the manual**, together with the documentation of all the accessories of the boiler and of the system, for any further consultation you may need.
- ▶ **The installation** must be carried out by a qualified technician, in accordance with manufacturer instructions and with the relevant requirements of the current issue.
- ▶ **Carbon monoxide (CO) danger:** the CO is a no-smelling and no-colour gas. When a forced draught boiler with air intake from the room (appliance type B₂) is installed, permanent ventilation of the installation room is mandatory and extremely important. Ventilation must be made and sized in compliance with Laws and Rules in force. Whatever manumission, closing or neutralization of the permanent ventilation could lead to very serious consequences to people in the rooms, as intoxication by CO, permanent damage and death. Besides, the CO and O₂ mix can be explosive.
- ▶ A **qualified technician** is a person with a specific technical competence in the field of the heating appliances for domestic use and domestic hot water production, in compliance with Laws and Rules in force.
- ▶ The **operations that the user can do** are only and exclusively the ones contained in the "USER GUIDE" section.
- ▶ The manufacturer has no contractual and extra-contractual responsibility for any damage arising from wrong installation, wrong use and non-observance of current laws and instructions given by the manufacturer himself.
- ▶ **Important:** this gas boiler is used to heat the water at a temperature lower than the boiling one, at atmospheric pressure; it must be connected to an heating system and/or to a domestic hot water system, in accordance with its features and power.
- ▶ Packing items (cartons, nails, plastic bags and so on) **must not be left within children easy reach**, as they are potentially dangerous.
- ▶ **Before any cleaning or servicing operation**, disconnect the boiler from the mains electrical supply by means of the main electrical switch and stop the gas supply by means of the suitable cock.
- ▶ **In case of fault** and/or bad operation of the appliance, disconnect it immediately and do not try to repair it by yourselves.
- ▶ **Boiler servicing and repair** must be carried out exclusively by qualified technicians, which will use original spare parts. Strictly observe the above requirement, avoiding any risk of compromising the appliance safety.
- ▶ **If the appliance should be definitively dismissed**, remove or cut off any potential dangerous item. *Dispose of it according to the regulations in force (page 59).*
- ▶ **When transferring the appliance** (e.g. leaving it installed after a removal or a sale of the building), make always sure that the instructions manual is close to the boiler for the future use of new owners and/or installers.
- ▶ This appliance **must be used for its clearly recommended utilization only**. Any other utilization must be considered dangerous and incorrect.
- ▶ It is strictly forbidden to use the appliance **for different purposes** than the specified ones.
- ▶ This appliance must be **installed exclusively to wall**.

Safety warnings symbols legend

 Generic safety warning	 Electrical danger (fulguration)	 Physical danger (personal damage)
 Thermal danger (burns)	 General warning or advice to avoid material damage or to achieve improvements	

References to Laws and Norms

All references to laws and laws contained in this handbook, as well as all installation, maintenance and use prescriptions and the relevant pictures, are relevant to European and/or Italian regulation.

All laws and norms in force in the territory where the installation takes place prevail on the indications contained in this handbook, that are inconsistent with them.

 All the **references to norms and national laws** mentioned in this handbook are indicative as laws and norms are subject to issues and integrations by the authorities in charge. **Also comply to eventual local norms and laws** (not mentioned in this handbook) in force in the territory where the installation takes place.

Personnel in charge of installation

 **Always comply with national and/or local regulation about WORK SAFETY of Personnel in charge of installation.**

 Always proceed with caution when handling the boiler and carrying out installation/maintenance work as metal parts may cause injuries such as cuts and abrasions. **Wear personal protection devices** (especially gloves) while doing the above mentioned operations

Installation, use and maintenance

 **Always comply with national and/or local regulation about BOILER INSTALLATION.**

User warnings

Important



In case of gas smell:

- 1 - **do not press electrical switches, use the telephone or other objects that can provoke sparks;**
- 2 - **open immediately the windows and the doors in order to cleanse the room air;**
- 3 - **close the gas supply taps;**
- 4 - **call a qualified technician.**



Do not obstruct the ventilation openings of the gas boiler room, in order to avoid possible dangerous situations as the creation of poisonous or explosive mixtures.

First starting up and Use



The first starting up and the maintenance of the boiler must be performed by a professionally qualified staff (for example the installer or the Service Centres authorized by ITALTHERM)

The latter will check that:

- ▶ the label technical data of the gas boiler correspond to those of the gas available;
- ▶ the main burner regulation is compatible with the gas boiler output;
- ▶ the chimney works correctly, expelling the combustion products;
- ▶ the air supply and the combustion products evacuation work correctly, in accordance with the requirements in force;
- ▶ the conditions for a correct ventilation are guaranteed, also when the gas boiler is located inside a closed space (with suitable characteristics).



This boiler is designed and prepared to be supplied with Natural Gas G20 (Methane). It can be set, just by means of electronic settings, but always by a qualified technician, to operate with Commercial Propane G31 or Air/Propane G230. It must never be used with **butane gas G30** (that can be present, pure or mixed with Propane G31, in the portable gas bottles for cookers).



The User must not touch sealed items nor break the seals. Only specialized technicians and the official technical service can break the seals of sealed items.



The boiler is fitted with safety devices that block operation the case of problems with the boiler or related systems. These devices must never be disabled: if a device intervenes frequently, have a qualified technician located the cause, even in systems to which the boiler is connected, and in the flue intake/outlet system that must be efficient and made according to the laws in force (see examples in paragraph "Flue systems" on page 21). If a boiler component has failed, you must only use original replacement parts



When the boiler is off for a long period see the Paragraph "Boiler inactivity" on page 9 for the necessary precautions about the electrical supply, the gas supply and the protection against freezing.



Do not touch the heated surfaces of the boiler, as the doors, the flue, the chimney pipe, etc., also after the boiler operation because, for a certain time, these surfaces are overheated. **Any contact with them can cause dangerous scalds.** It is then forbidden to let children or inexperienced people be close to the boiler, during its operation.

- ▶ Do not expose the wall hung gas boiler to water or other liquids sprinklings, or to vapours directly coming from gas cookers/hobs.
- ▶ Do not obstruct the air intake or flue outlet terminals, even momentarily or partially.
- ▶ Do not put any object on the gas boiler and don't leave any flammable liquid or solid materials, (e.g. paper, clothes, plastic, polystyrene) in its proximity.
- ▶ This appliance is not intended for use by persons (including children) with reduced physical, sensory or mental capabilities, or lack of experience and knowledge, unless they have been given supervision or instruction concerning use of the appliance by a person responsible for their safety. Children should be supervised to ensure that they do not play with the appliance.
- ▶ If the gas boiler is going to be definitively unused, call a qualified technician to carry out all required operations, checking in particular disconnection of gas, water and electrical supplies.
- ▶ **Only for those models that draw directly from the installation room** (type B appliances installed indoor): the installation of aspirators, fireplaces or similar appliances in the room where the type B appliance is installed (and in adjacent rooms in case of indirect ventilation) is prohibited except in cases foreseen by rules in force and anyway the installation must be made in compliance with all specific safety measures mentioned in the rules and laws in force, even in case of modifications or additions.

Installation, first starting up, maintenance and servicing

All operations for installation, first starting up, maintenance, servicing and gas conversion **must be carried out by qualified technicians**, in accordance with the Norms and Laws in force.

Maintenance operations must be carried out in compliance with the manufacturer prescriptions, and in compliance with the laws and rules presently in force for what is not mentioned in this handbook; we advice to perform them at least once a year to maintain the boiler's performance.

Appliance booklet or central plant booklet

All appliances must have an appliance booklet (for outputs less or equal 35 kW) or a central plant booklet (for outputs more than 35 kW). All maintenance and servicing operations and combustion checks must be written on the booklet, together with the name of the person responsible for servicing.

Combustion checking

Combustion checking consists of a control of the boiler efficiency. Boilers that, after the checking, will have efficiency rates lower than the ones required and not changeable with suitable adjustments (that must be performed by qualified technicians), must be replaced.

Boiler operation and servicing

The user (owner or tenant of the flat where the boiler is installed) or the administrator of the block of flats (in case of a central heating system) are responsible for the appliance operation and servicing; they can both transfer the responsibility of the servicing and eventually of the operation to another person, which must be a qualified technician as indicated by the Laws. Even if the user or the administrator decide to assume personally this responsibility, ordinary servicing of the warm air heater and combustion checks must be anyway carried out by a qualified technician



Boiler controls

Remote control

All user controls of the boiler are located in the Remote Control, which is supplied with its own instruction manual.

For the description of all controls and for the boiler management operations that are not included in this booklet, refer to the instruction manual of the Remote Control.

(i) Therefore, when removing the Remote Control from its box, take care to **keep the relevant instructions for use. Attach them to this instruction booklet.**

The original Remote Control is much more than just a **chronothermostat**:

- it **optimises the boiler operation**, interfacing with the relevant electronics;
- it features a built-in **weekly climatic programmer, easy to set and to use**, but extremely complete:
 - for example, it determines the boiler power according to the difference between set and measured temperature
 - for this and other reasons, it should be formally considered as an **“advanced thermoregulation system”**
- it responds to **all boiler controls** and provides the Technician with **diagnostic information and further functions**;
- easy to install, it is connected in place of the Ambient Thermostat;
- it is powered from the boiler through the data link, with extra-low voltage, therefore it is electrically safe and **it doesn't need batteries** or additional power supply connections.



Commands on the lower side

1 GAS cock

Commands outside the boiler

Conveniently positioned in the property (usually by the installer or by the person in charge of installing the electrical system), there is the **power supply omnipolar switch**: the position of this device must be known and accessible to the User since it has to be used when it is necessary to cut off the power supply to the boiler. The presence and features of the omnipolar switch are prescribed by rules in force.

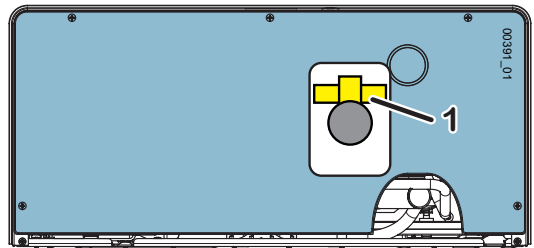

Service Control Panel

The electric box that contains the electronic control unit (pos. **13** on page 52) is complete with standard controls. It cannot be accessed from the outside, but it is a useful control panel that can be used by the Technician in the following cases:

- **maintenance** with access to functional parameters or procedures reserved to the Technician;
- **activation of temporary emergency** of the boiler basic functions, in case of connection problems or malfunctioning of the Remote Control;
- **enabling of the Remote Control** to control the boiler (see page 56).

for details, see the appendix "The Service Control Panel" on page 55.

Typical use

Preliminary operations

- ▶ Be sure the gas cock **1** is opened.

the heating system should already be filled during the installation phase at the proper pressure of **1°Bar in a cold state**. The pressure value cannot be directly read (the pressure gauge is inside the boiler), but should it be insufficient, when the boiler is electrically powered, the system that automatically restores the pressure will be activated, with signal **E18** or **E19** or **E21** on the Remote Control.

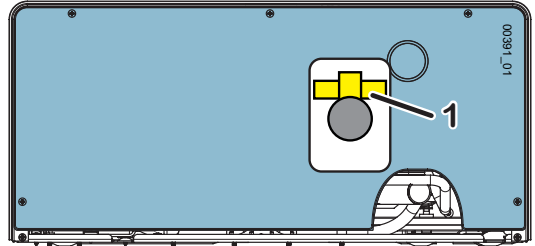

Note: additional information on these alarms are available in paragraph "Alarms - boiler block" on page 41. For details on the initial manual filling of the system, **performed by the Technician**, see "Heating system filling and pressuring" on page 17.

(i) The system pressure raises with the temperature: a too high initial cold-system pressure could lead to **water drain from the 3 Bar safety valve** after the system heating-up.

Boiler use

All the information on boiler use for the User is described in the instruction booklet of the Remote Control, **where the boiler is referred to as "UC"**.



Incidental malfunctioning



Avoid performing personally any intervention that are job of the technician, for example the ones on the electrical circuits, on hydraulic system or on the gas system, and whatever other operation that's not mentioned in this "User Guide" section and expressly allowed to the User. Always address yourselves to qualified personnel.

Boilers must be always equipped with original accessories only.

ITALTHERM Srl is not responsible for damages caused by the incorrect, wrong or unreasonable use of not original materials.

The burner doesn't turn on

- ▶ Check whether the Remote Control uses an alarm code; in this case, depending on the code, try to restore the operation as described in paragraph "Alarms - boiler block" on page 41.
- ▶ If the Remote Control display is completely off, the Remote Control connection may be insufficient, but first make sure that the **power supply omnipolar switch** of the boiler is not turned off or that there are no other power supply interruptions.
- ▶ Check that the value of the set ambient temperature is not higher than the current one, in this case it is not necessary to turn on the burner. If you still want to turn on the burner, it will be necessary to set, on the Remote Control, an ambient temperature higher than the current one (see the instruction booklet of the Remote Control).

Shortage of domestic hot water production

- ▶ Check that the set temperature value of domestic water is not too low, in this case adjust it (see the instruction manual of the Remote Control).
- ▶ Have the boiler internal water filters checked by a technician.
- ▶ Have the boiler adjustments and correct programming checked.
- ▶ Have the domestic water exchanger checked and, if necessary, have it cleaned.

(i) Remark: where the water hardness value is too high, it is suggested the installation of a softening device, in order to prevent the limestone precipitation; this operation avoids a frequent cleaning of the coil.

Boiler inactivity

The effects of the periods of inactivity can be relevant in particular situations such as in flats used only for some months per year, most of all in cold places.

The user will have to decide to put the boiler in the **SAFETY SHUT OFF state** disconnecting all the supplies, or to **leave it on OFF mode (but electrically supplied) in order to let the Anti Frost Function work**. When there is the possibility of freezing it is convenient to chose between the advantages and the disadvantages of the SAFETY SHUT OFF and of the Stand By/Anti Freezing Way.

Safety shut off

- ▶ Turn off the general switch on the Electrical Supply Line of the Boiler;
- ▶ Close the Gas Tap;

(i) When it is expected that the temperature is going to decrease under 0°C, call a technician to do the following:

- Fill the system with an anti-freezing solution (unless the system was already filled with said solution) otherwise it must be completely emptied. Notice that if it had been necessary to restore the pressure (because of possible loss) in an heating system already filled with an Anti freezing solution, the concentration of the solution could have decreased and it could not guarantee the Anti freezing Protection.
- Let the condense collector syphon be emptied unscrewing its inferior cap.
- completely empty the hot and cold sanitary water system, including the sanitary circuit and the boiler's sanitary exchanger.

Remark: the boiler is equipped with a system which protects the main components from the exceptional cases of mechanical lock, due to the inactivity in presence of water and scale. The anti-locking function can't work in Safety shut off mode, because of the lack of electrical supply.

(i) Before switching on the boiler, **make sure that the circulating pump is not blocked** due to inactivity: in the middle of the cap there is a hole (should there be a cap, remove it) that gives access to the rotor shaft; **push and turn it using a suitable tool**, usually a "Phillips" screwdriver.

OFF mode with anti-frost & anti-locking function

When boiler is left to **OFF** for the inactivity period, it will be protected from freezing through functions set in the control equipment and devices specifically intended for this type of boiler (designed for outdoor installation):

▶ when the ambient temperature detected by the Remote Control is near 0°C, the heating system is activated;

(i) The "Room Anti-Freeze" function does not ensure protection of the domestic water circuit outside the boiler, in particular of the areas not reached by the heating system. It is therefore necessary to have the parts of the domestic hot and cold water system emptied, since they may be likely to freeze.

▶ when the temperature detected by domestic hot water probe is near 0°C, the domestic water operating mode is activated (without hot water withdrawal);

▶ there are electric anti-freeze heaters under the funnel of the condensate, on the system filling device and on the domestic water inlet and outlet hoses, since these parts are not covered by the anti-freeze action of the two previous functions. They are automatically controlled only when required because of low ambient temperatures.

Moreover, in this status, boiler periodically activates main internal components to avoid the rare blocking cases caused by inactivity in presence of water and limescale. This happens also when boiler is locked-out (alarm signal on the remote control display), but only if system pressure is correct.

In order for these systems to be active:

- the boiler must be receiving gas and electricity;
- boiler must be left on **OFF** mode by means of the Remote Control;
- system pressure must be correct (1÷1.5 bar in a cold state, minimum 0.5 bar) or the cold water supply should be available on boiler's input, to allow the automatic filling

In case of gas supply failure, or if the boiler locks for other reasons (alarm warning on Remote Control display) the burner won't turn on. Nevertheless, any time it is possible, the pump will work, making the water circulate in the system and reducing in this way the possibility of freezing.

(i) **ATTENTION:** the anti-frost protections cannot intervene in the absence of electricity. If you anticipate this possibility, we recommend you add a good brand of anti-freeze to the heating system, following the producer's instructions.

We recommend to ask directly the installer/technician about the type of antifreeze product put in the heating system during installation.

When the power comes back on, the boiler will check the temperature measured by the two probes and, if it suspects freezing verified by a particular automatic control cycle, alarm 39 will be triggered. For more details, see the relative description in the paragraph "Alarms - boiler block" on page 41.



We recommend that you completely empty the hot and cold sanitary water system, including the sanitary circuit and the boiler's sanitary exchanger. The anti-frost function does not protect the sanitary circuit outside the boiler.



Law and regulation prescriptions for the installer



Always comply with national and/or local regulation about BOILER INSTALLATION.

Always comply with national and/or local regulation about WORK SAFETY of Personnel in charge of installation.

Characteristics of the room: as this boiler has an heat output lower than 35 kW (about 30000 Kcal/h), it is not required to install the appliance in a dedicated room, provided that the room complies with the regulation in force and that all installation rules assuring a safe and regular gas boiler operation, are strictly respected.



Permanent ventilation of the installation room is mandatory and extremely important when a boiler with air draught from the installation room (B... appliance type) is installed. Ventilation must be made and sized in compliance with Laws and Rules in force.

Presence of other appliances: the presence of other appliances (especially if they interfere with the boiler draught) can be forbidden by the regulation in force or can require modifications (e.g. the enlargement of the ventilation opening or the making of new ones).

Instructing the user: at the end of the installation, the installer must:

- explain the operation of the boiler and its safety devices to the user;
- give this user this booklet and the documentation within his/her competence, duly filled in where required.

Dimensions and connections

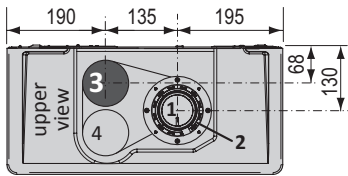
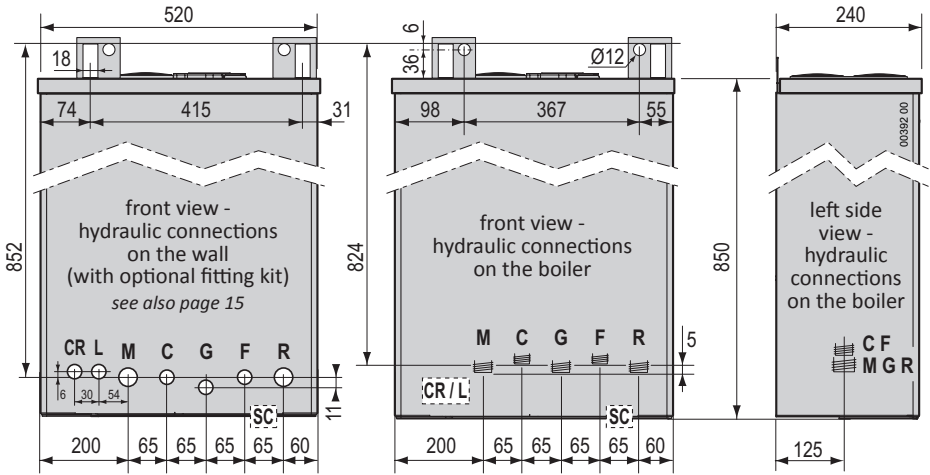

Legend:

- 1 Flue outlet
- 2 Air intake for coaxial system
- 3 Air intake for split-pipe system
- 4 preset for an accessory not foreseen on this model; **don't use as air intake!**
- M System flow ($\frac{3}{4}$ "
- C DHW outlet ($\frac{1}{2}$ "
- G Gas: connection on the boiler $\frac{3}{8}$ "; on the wall, using the optional original fitting kit $\frac{1}{2}$ "
- F Fresh water inlet ($\frac{1}{2}$ "
- R System return ($\frac{3}{4}$ "
- CR/L Indicative position for electrical power supply and Remote Control wirings
- CR Remote Control wiring
- L Electrical power supply wiring
- SC Indicative position for the condensate drain

Pump capacity diagram

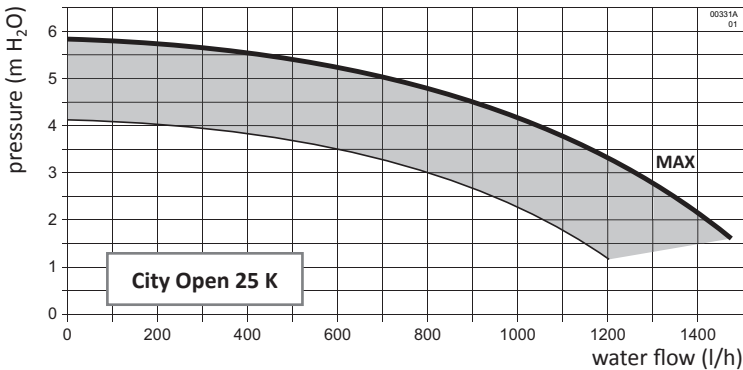

See also "Pump settings" on page 41. The curves **MAX** shown in these graphs refer to the head available to system at factory setting (see par. 35 on page 35) and are net of the load loss of the circuits inside the boiler. The area represents the working range with pump in modulating mode (see par. 33 on page 34)

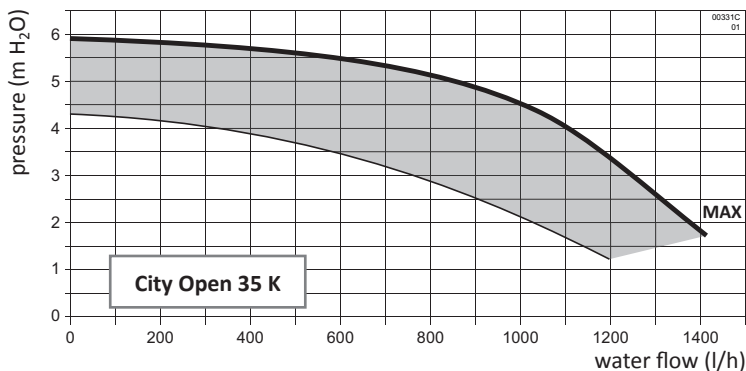

Warnings for the installation of optional kits or special systems

Floor heating system

(i) The safety thermostat(s) that protects the floor against overheating (that could damage the cladding, the structure or the system itself) must be installed on the flow starting end of the serpentine embedded in the floor itself. It should not be installed on the system flow pipe in proximity of the boiler, otherwise frequent and unjustified boiler locks, caused by its triggering, are possible.

Specifications for intake air

Air must be withdrawn from places free of pollutant (like fluorine, chlorine, sulfur, ammonia, alkaline or similar agents). In the event of installation of the boiler in atmospheres with not negligible presence of aggressive chemical substances (e.g. hairdressing salons, laundries) we recommend to foresee the air intake from outdoor, choosing the type C installation.

Domestic water supply characteristics

The cold water inlet pressure must be lower than 6 Bar. Besides, for an optimal boiler functioning, water pressure **should be more than 1 Bar.** A lower pressure could make difficult to restore correctly the pressure the heating system, and reduce the flow of hot water available from the boiler.

(i) In case of higher pressure it is **indispensable to install a PRESSURE REDUCER** upstream the boiler.

The cleaning frequency of the DHW heat exchanger depends on the water supply hardness. If the water hardness is more than 25° fr it's required to install a softener to bring the hardness below that value.

Besides, the presence of solid residuals or impurities in the water (for example in case of new systems) could compromise the correct functioning of the boiler. For DHW production systems, the regulation in force prescribes a safety filter to protect the systems.

(i) The condensing burner/exchanger assembly requires **particular characteristics for the heating system liquid**, more restrictive than the ones of the inlet domestic water. See the "Heating" section of the table "Technical data" on page 50.

Protection against freezing

Boiler is protected from freezing through functions set in the control equipment that heat the concerned parts when temperatures go below the minimum values predefined in the factory.

The temperatures of the heating circuit inside the boiler (primary circuit) and of the domestic water circuit are detected by the same probes that control their operations. Rooms, and consequently the heating system outside the boiler and radiators, are controlled through the ambient temperature probe integrated into the Remote Control.

Anti-freeze heating is obtained by turning on the burner and the circulator (both in heating and domestic water use) and/or by activating electric anti-freeze heaters properly applied on boiler internal hydraulic circuits, in particular in the sections of the domestic water circuit that cannot be heated by the primary circuit.

In case of gas supply interruption or boiler shut-down, boiler cannot be switched on. In this case, the circulator is activated and the anti-freeze heating is carried out only by electric heaters.

(i) If some part(s) of the system external to the boiler could be subject to freezing risk, it is advisable to fill the heating circuit with, instead of water, an antifreeze liquid specific for heating systems, propylenic glycol based, following the instructions of its manufacturer. Pay attention to the correct product concentration: adding those substances to the heating water in incorrect dose could lead to the deformation of the seals and cause unusual noises during operation.

ITALTHERM S.r.l. will not be held responsible for consequent damages.

Instruct the User about the antifreeze function of the boiler and about the antifreeze product added in the heating system.

Outdoor installation in a partially protected place

This type of forced draught condensing boiler has been designed to be installed **outdoor in partially protected places**.

The boiler minimum and maximum working temperatures are mentioned in the paragraph "Technical data" on page 50 and on the boiler data plate.

The materials used for the boiler installation, including the devices and/or the materials used for thermal insulation, should be so to **maintain their functionality** within the temperature range indicated on the data plate.



If the place where the boiler is located is converted **from outdoor to indoor** (e.g. veranda) it will be necessary to **verify the compliance** of the new configuration with the laws and rules in force, and to make the modifications required.

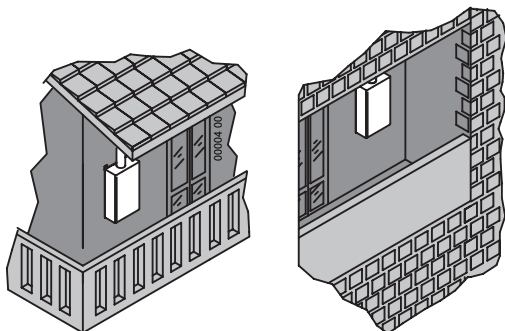

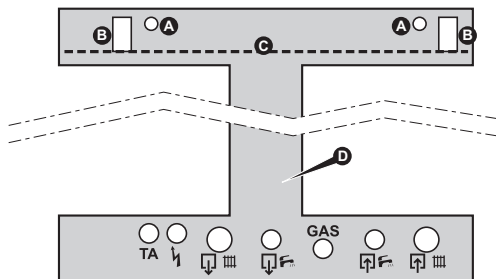
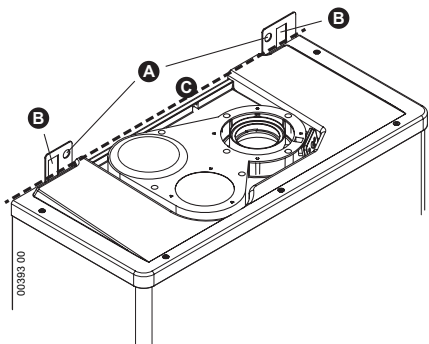

Positioning and fastening

Remark: A re-usable metal jig (D in the figure) can be ordered separately, so as to facilitate connections and fixing points positioning (when the original connection kit is used). **If the metal jig and/or the original connection kit are not used, refer to the paragraph "Dimensions and connections" on page 12 for the position of the connections directly on the boiler.**

- ▶ Locate the exact position of the boiler considering the sufficient clearances: at least 50 mm from each side, 50 mm from the front and 300 mm on the bottom side
- ▶ Choose the fastening/hooksing option among **A** or **B**, depending on the fixing devices used or already available if any (open hooks; wallplugs; "stud" type with nut).
- ▶ If the metal jig is used, hang it on the wall using the same fixing devices and the holes or slots **A** or **B**.
- ▶ Fix up the connections and all ducts for heating flow and return, cold water, hot water, gas and electrical cables, predisposing them in the holes of the metal jig or, as an alternative, respecting the measures in the paragraph "Dimensions and connections" on page 12. The upper edge of boiler's body, used as a reference in the paragraph "Sizing the flue system" on page 24, is represented by the dotted line **C** in the figure.
- ▶ Remove the jig (if used) and hang the boiler to the fixing devices, using the chosen holes or slots **A** or **B**.
- ▶ **Remove the plastic caps** placed to close the hydraulic connections on the boiler.
- ▶ Proceed with the hydraulic, gas, electrical and flue connections following the instructions and warnings reported in the following paragraphs.

	Heating Flow (3/4")
	Hot Water Outlet (1/2")
GAS	Gas (1/2")
	Cold Water Inlet (1/2")
	Heating Return (3/4")
	Electrical Power Supply
TA	Room Thermostat

(i) The connections of the boiler are engineered to fit plain couplings with screw ring, interposing a plain gasket of suitable size and material, that ensure a reliable seal even without excessive tightening force. They are NOT suitable for hemp, teflon tape or similar materials

Hydraulic system (DHW and heating)



Make sure that the hydraulic and heating systems ducts **are not used as earth connections of the electrical system**. They are absolutely NOT SUITABLE for such a use. Besides: they don't guarantee the earth dispersion; in case of electrical fault they could generate a fulguration risk; there could take place galvanic currents in the pipings and consequent corrosion and hydraulic leaks.

Advices and suggestions to avoid vibrations and noises in the system

- ▶ Do not use pipes with reduced diameters;
- ▶ Do not use bends with small radius and reductions of important sections.

Cleaning and preservation of the systems

The efficiency, the reliability and the safety of the boilers, as all generic thermal systems and components, depend strictly on the features of the water that supply them and on their treatment.

A proper treatment of the water improves the protection of the systems against corrosions (and therefore perforations, noise, leaks, etc.) and limestone incrustations that drastically reduce the efficiency of the thermal exchange (consider that 1 mm of limestone incrustations reduces of 18% the thermal exchange of the heating element on which it has been formed).

ITALTHERM guarantees its products only if the characteristics of the water comply with UNI 8065, reported also in laws on energy saving.

(i) Thoroughly wash the heating system with water, before connecting the boiler. This will eliminate residual like welding drops, slag, hemp, mastic, mud, rust and other dirt from pipes and radiators. Otherwise, these substances could enter the boiler and damage the internal components (pump etc.).

- ▶ **In case of old or very dirty systems, to wash them use specific, proven efficiency products**, in the suitable quantity and following the instructions of its manufacturer.
- ▶ If the water on boiler inlet is harder than 25° fr, it's required to install a softener to bring the hardness below that value, as required by the reference regulation.
- ▶ For floor system and generally all low temperature systems, the water treatment product must have filming action (protection against corrosion and incrustation) and action against bacteria and algae.

Heating system

- ▶ Connect the safety evacuation ducts of the boiler to an evacuation funnel. If safety valves are not connected to an evacuation device, their intervention could flood the room. The manufacturer cannot be held responsible for any damage arising from that situation.

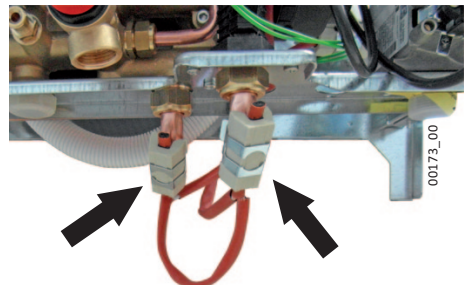

Electric anti-freeze heaters

(i) Remember to hook the two spare electric heaters to the pipings for cold water inlet **F** and hot water outlet **C**.

Condense drain

Insert the flexible pipe of condense outlet inside the outlet funnel (or other inspectable connection device) properly installed for this purpose, or in the outlet funnel of the safety valve, in case of the above mentioned outlet is able to receive the acid liquids of the condense as foreseen by the norms in force in matter of condensing boilers.

(i) Requirements for the condense drain system:

- It must be made in a way that doesn't allow the condense freezing or other blockages, and it must not allow modifications or obstructions
- before the first starting up of the appliance, ensure that the condense can be correctly drained
- if the intended use of the building unit foresaw the installation of a condensate neutralization system, make sure that you have the relevant instructions for use, cleaning and maintenance

Heating system filling and pressuring

Once all system connections have been carried out, proceed with system filling. This operation should be made with care, respecting the following steps:

(i) During this operation, the boiler should not be electrically supplied.

If the boiler is supplied, an automatic system filling cycle will start. If the system is empty, this operation will be incorrectly performed and it will cause, uselessly, many boiler blocks.

Remark: we suggest to remove the boiler's casing (see "Access to the inside of the boiler" on page 29) to easily access all devices involved in this operation.

- ▶ Open the radiators venting devices;
- ▶ Check that the plug of the automatic air vent, incorporated in the boiler circulator, is unscrewed: if not, unscrew it and leave it unscrewed, even afterwards, for normal operation;
- ▶ If it's required to fill the system with anti-freeze solution, do this operation, then hermetically close the connection or the valve used to put the solution in, to allow the pressurization.
- ▶ Gradually open the filling cock **2** by using a suitable flat screwdriver;
- ▶ Check the correct functioning of automatic venting devices, eventually installed;
- ▶ Close the radiators venting devices as soon as water flows out of them; Make sure, by reading the pressure gauge **1**, that the pressure reaches the optimal value of **1.0 bar (max 1.5 bar)**;
- ▶ Close the water filling cock **2** and bleed each radiator again;
- ▶ Repeat the venting and pressurization operations until the air is completely purged from the system.

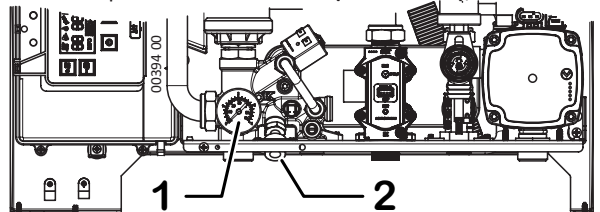

Gas connection

Due to various installation possibilities, the gas cock **3** supplied with the original Connections Kit has a simple male $\varnothing \frac{1}{2}$ " connection, facing the rear of the boiler. *The gas pipe 4, upstream the gas cock 3, should be supplied by the installer.*



While connecting the gas inlet of the boiler to the gas supply piping, it is **MANDATORY** to insert a **PLAIN GASKET**, whose dimensions and material must be adequate. Connection is **NOT** suitable for hemp, teflon strip or similar materials. Because of the type of fitting, the use of those materials does not make the suitable seal with consequent gas leaks!



This boiler is designed and prepared to be supplied with Natural Gas G20 (Methane). It can be set, just by means of electronic settings, but **always by a qualified technician, to operate with Commercial Propane G31 or Air/Propane G230.**

It must never be used with Butane gas G30 (that can be present, pure or mixed with Propane G31, in the portable gas bottles for cookers) **therefore, if the boiler is prepared for operation with commercial Propane G31**, we recommend to **inform the supplier of the fuel, for example, by applying a suitable warning on the gas tank** or in its immediate vicinity, **so that it is visible to the employee when it is being refilled.**



Using Propane gas G31, it is **absolutely necessary to install a pressure reducer upstream the boiler. Failure to do this, the gas valve of the boiler will get damaged. The inlet gas pressure must be compliant with the one specified in "Technical data" on page 50.**



The gas connection, as generally the boiler installation, must be done by qualified personnel as prescribed by the regulation in force, because a faulty gas connection could lead to fire, explosion and other very serious damages to persons, animals and objects. The manufacturer cannot be held responsible for any damage arising from that situation.

► Verify what follows:

- cleaning of all system gas pipes in order to avoid the presence of work residuals that could compromise the correct boiler functioning;
 - gas line and ramp conformity with laws and rules currently in force;
 - internal and external tightness of the gas system and connections;
 - supply pipe must have a section greater than or equal to the boiler one;
 - supply gas must correspond to the one for which the boiler has been set: otherwise, it's mandatory to ask to qualified personnel to set the boiler for the correct gas type;
 - an interception valve must be installed upstream the appliance.
- Open the meter valve and purge the air that is inside the system pipes (including all the appliances).

Electrical connections



The link of the Remote Control works with a safety extra low voltage (SELV); connect it to the supplied Remote Control only, as the boiler can't work without it. **On NO account must any electrical voltage be applied** to these terminals.



To avoid malfunctions due to electrical noise, the Remote Control connections, as well as all low-voltage connections, should be kept separated from power supply cables, e.g. by enclosing it into separate raceways.



During the connection of cables from the boiler, make sure that they are not tight and make a slack that allows the control panel to be fully tilted.

The boiler must be connected to a 220÷240V - 50Hz electrical power supply. In any case, the power supply voltage must be within the range -15% ... +10% from the nominal value (230V); otherwise it may cause malfunctions or failures. It is necessary to respect the polarities L-N (Live L=brown; - Neutral N=blue) - otherwise the boiler may not work - and the earth connection (yellow-green cable).



Place upstream the boiler a bipolar switch in compliance with the regulation currently in force. The installation must be made complying the regulation currently in force and generally with the standard craft rules.

For the general electrical supply of the appliance the bipolar switch should be used. The use of adaptors, multiple taps and extensions is not allowed.

If the supply cable must be replaced, use one of the following cable types: H05VVf or H05-VVH2-F. **It is mandatory the earth connection in accordance with the rules actually in force.** To replace the cable, open the control panel cover, unlock its fastening device and disconnect it from the terminals. Install the new cable proceeding in the reverse way. When connecting the cable to the boiler, it's mandatory:

- to leave the Earth wire about 2 cm longer than the other (Live and Neutral) wires;
- to lock the cable upstream the terminals by means of the suitable fastening device.



Electrical safety of the appliance is only achieved when it is well connected to an efficient earthing system, executed as indicated by the safety rules actually in force.

A qualified technician must check that the electrical system is in line with the maximum power allowed by the boiler, indicated on the data plate, with particular attention to the cables section.



ITALTHERM S.r.l. declines any responsibility for damages to persons, animals or things caused by the faulty or missing connection of the boiler earthing and by failure to comply with the rules.

Remote Control installation and connection

(i) Extract the Remote Control from its package. **Keep the relevant user instruction booklet and annex it to this Manual.**

(i) To avoid malfunctions due to electrical noise, the Remote Control connections, as well as all low-voltage connections, should be kept separated from power supply cables, e.g. by enclosing it into separate raceways.

The maximum overall cable length shouldn't exceed 50 m.



Nor the Remote Control neither the relevant cable coming from the boiler must not, for any reason, be connected to the 230Vac supply mains.

(i) Make sure that boiler is not electrically powered, especially during the connection.

(i) ***IMPORTANT!*** For the Remote Control to be correctly detected by the boiler electronics, **it is essential to set the latter to Summer / Remote Control mode** using the service Control panel inside the boiler, as described in paragraph "Boiler and Remote Control activation" on page 57. ***Otherwise the Remote Control will not work.***

- ▶ Install and connect the Remote Control as described in the relevant Instruction Booklet;
- ▶ for the connection from the boiler side, see the CR component in "Electrical diagram" on page 53. Please remember that the connection is NOT polarised.

Flue systems

Intake/outlet flange

The boiler is equipped with a flange for connecting inlet and outlet flues pipes; this flange has been studied for collecting rain/water that may creep into the inlet pipe and for avoiding that rain reaches the burner's fan.

Rain/water collected is conveyed, thanks to silicon tube, to internal siphon for draining

On the flange there are:

- ▶ outlet pipe connection **1**, both coaxial and separate configurations;
- ▶ inlet for coaxial configuration **2**;
- ▶ inlet pipe connection for separate configuration **3** (remove the cap only if you are installing the separate configuration);
- ▶ prearrangement **4** for an accessory not provided with this model (to be NOT opened).

(i) Pay attention to only connect **inlet separate** pipe to **connection 3**, **instead of prearrangement 4**. This wrong connection could allow rain/water going to fan and burner, damaging it.

Installation of the flue intake/outlet flange gasket



IMPORTANT: For a correct and safe operation of the boiler it's necessary to install, on the intake/outlet flange **2**, the gasket **1** included in the boiler's documents bag. Before inserting the flue outlet pipe it's therefore very important to correctly place the gasket on its seating as indicated in the figure.

General indications

To grant the functionality and efficiency of the appliance it is indispensable to realize intake and outlet ducts using flue accessories specific for condensing boilers.

(i) **WARNING:** the specific flue accessories components for condensing boilers, especially the parts which are in touch with the flues outlet, are so projected because they are made with **plastic materials acids resistant**, but because of their nature, **they are not suitable to resist to the higher temperature** of the flues of the traditional boilers. So it is **not possible to use traditional flue components for the outlet ducts of the condensing boilers, neither vice versa**.

(i) When installing the pipes, we recommend lubricating the inside of their gaskets exclusively with **silicone** lubricants since their material (EPDM peroxide) is not compatible with other types of oils or greases

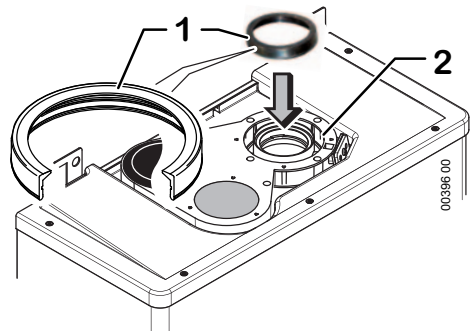
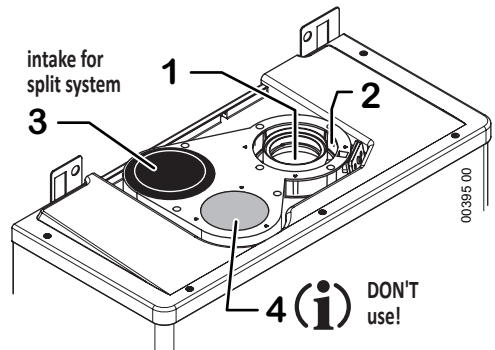

If it is possible, we recommend to foresee (referring to the direction of the air/flue, see examples on page 23) an upwards slope for all the intake and outlet ducts, in order to:

- ▶ PREVENT the water or dust or other objects entrance inside the INTAKE duct. In case of coaxial ducts, use the special horizontal terminal, which is especially built to respect these slopes only for the first length of the intake duct;
- ▶ FACILITATE, in the OUTLET duct, the flowing back of the condense towards the combustion chamber, which is built to work in these conditions and to discharge the condense. If so it is not possible, or if there are some points where the condense stagnates inside the outlet duct and if it is not possible to avoid this through a modification of the slope of the ducts, these points must be drained using the specific kit of condense collector (consult the commercial catalogues of the original accessories), and ducting the condense formed towards the outlet duct as foreseen by the norms in force in matter of condensing boilers.

Air intake and flue outlet terminals should be protected by suitable approved flue accessories, to avoid environmental elements penetration.

Carefully follow the indications foreseen by the specific laws in force.

Respect the minimum and maximum flue length prescribed (see "Sizing the flue system" on page 24).

In case of flue outlet on wall, the positions and the distances prescribed by the regulation must be respected.

The **outlet duct is the assembly of components that connect the boiler to the point where the flues are discharged**. The outlet can be directly outdoor only in the case foreseen by the law in force and using at the end of the outlet duct a specific terminal.

In case you foreseen to discharge the combustion products through a **chimney** (for single user) or a **common flue** (for multiple users) the part of the evacuation system (the chimney or the flue) to which the outlet duct of the condensing boilers is connected, **must be declared suitable for this purpose by its producer**. In case of common chimney, keep in mind the laws in force regarding the typologies and rates of users.

Don't lean the flue pipe into the chimney, but stop it before the inner surface of the chimney. The axis of the flue pipe must intersect the axis of the chimney or of the flue duct.

In general situations the **evacuation systems** of the combustion products **must be properly declared suitable from the producer of the same system** for wet functioning, **or must be supplied by the appliance's producer** (gas boiler).

If the chimney (or the flue) were not suitable, it would be indispensable, to use it, to canalise it through specific ducts, so for example through the original flue accessories.

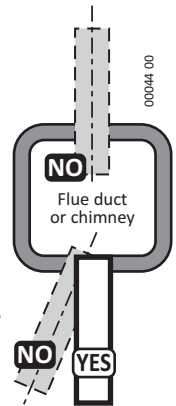

Sizing C₆₃ systems

Remark: if a flue system ITALTHERM original is installed, do NOT use this paragraph, but please refer to "Sizing the flue system" on page 24.

If you choose to use aftermarket flue components (this is suitably allowed by the C6 certification), **however strictly certified for condensation**, the installer will have to size the inlet and outlet system so as to obtain, during operation, **Delta P outlet/inlet** values within the specific min/max range of the boiler. The necessary information can be found in "Technical data" on page 50, "Connections" section, while the specific ones of the components must necessarily be supplied by their manufacturer

Examples of installation of intake and outlet ducts

We give you some correct and wrong examples of installation of intake and outlet ducts for condensing boilers (the slope are voluntarily represented in an exaggerated way).

A = Intake; **S** = Outlet. **1:** the most functional and economic solution is to let the condense come back towards the boiler**. **2-3:** if an obstacle prevents to install the ducts upwards, it is necessary to install condensate collectors, so as to avoid stagnations. **4:** if, respect to the air flow, the slope of the intake ducts is upwards (for their all length or at least only for the external tract) this is sufficient to prevent the rain water to reach the burner's fan*. **5:** so the intake must not be downwards*. **6:** do not let the condense go out from the flue outlet terminal. **7:** the coaxial intake/outlet duct must be installed so as the flues are upwards, and so the condense discharge itself towards the boiler. The terminal tract with intake head and outside with an outlet out axis must be horizontal placed and it is equipped with ribs which prevents the water entrance* in the external intake duct. The internal outlet duct is upwards and canalises the condense in the correct direction.

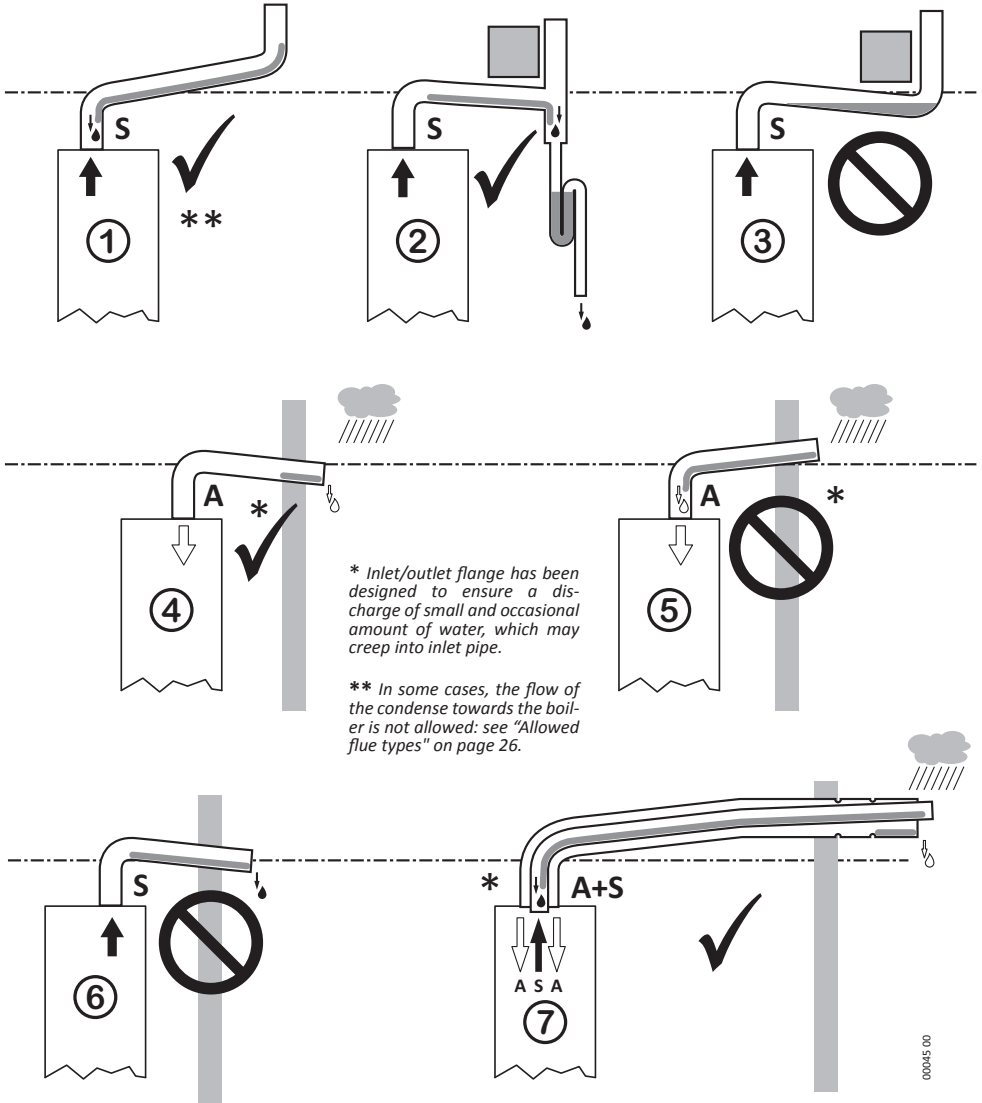

Sizing the flue system

(i) See "System length tables" on page 25 to size the ducts according to: boiler model; gas type; distance to be covered; pipes diameter.

In special cases (duct section 50mm diameters and/ or considerable lengths) it is possible to change few parameters to the boiler settings (by a technician). **Incorrect sizing would lead to problems** such as: incorrect combustion; out-specific emissions and returns; alarms for boiler block; fouling or premature wear of the combustion system.

Separate pipe system (C₄₃, C₅₃, C₈₃, C₉₃ *)

* **Remark:** Split pipes allow to make also C₁₃ and C₃₃ flue systems.

** **The dimensions on the duct axis are referred to the upper edge of the boiler's body, close to the mouth of the first 90° bend. The difference of level due to the slopes are not considered.**

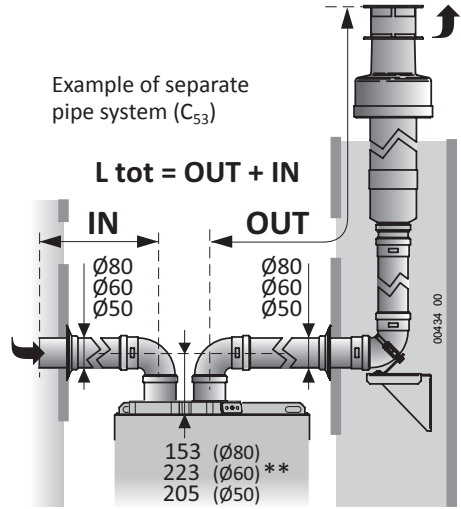

Coaxial system (C₁₃, C₃₃)

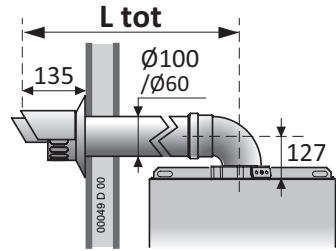
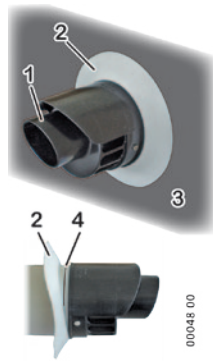
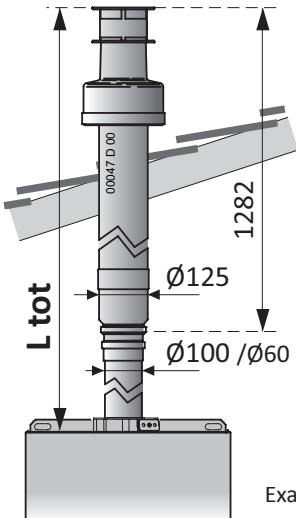

Example of horizontal coaxial system (C₁₃)

(i) Put the outlet coaxial horizontal terminal with the outlet head **1** UPWARDS, as indicated in the picture, respecting the measures in the drawing. Check that the elastic sealing collar **2** is housed in the groove **4** and against the outside wall face **3**.

Example of vertical coaxial system (C₃₃)

Flue system length

How to use the tables

- ▶ Each table is related to one model only and it's valid for the indicated gas types
- ▶ The data differ according to the diameter of the inlet and outlet system and the type of ducts used: rigid (smooth) or with flexible pipe (corrugated). Systems consisting of mixed duct types are not considered

- ▶ The boiler, with factory settings, covers a range of lengths that meets most of the applications. If necessary, it is possible to change some operating parameters to satisfy an increased range of lengths. The Service Centre is able to make this change.
- ▶ **L tot** is the maximum system length (physical of linear piping + equivalent of bends):
 - in the case of separate systems, it is the sum of the total lengths of the inlet sections (IN) + outlet (OUT). The horizontal system includes the 2 bends necessary to make the ducts horizontal, ie the 90° one on the air inlet connection and the 90° one on the flue outlet connection of the boiler
 - in case of coaxial systems, it's the physical length of this system. The horizontal system includes the first 90° coaxial bend on the flue connection of the boiler, to make the duct horizontal
- ▶ Bend, 90° or 45°
 - They are always intended as **additional** bends, that is to say that in the horizontal systems are those eventually installed **in addition** to those already foreseen for those systems. They must be included in the calculation of the **L tot** based on their equivalent length shown in the table.

System length tables

City Open 25 K	gas: G20 - G31 - G230		with factory settings			with modified settings <i>this operation must be performed by authorized technicians</i>		
	Diameter	type	L tot min÷max (m)	90° bend (m)	45° bend (m)	L tot min÷max (m)	90° bend (m)	45° bend (m)
Ø 80mm		rigid horiz.	1 ÷ 60	1.5	0.9			
		rigid vert.	1 ÷ 62	1.5	0.9			
		flexible	1 ÷ 62					
Ø 60mm		rigid horiz.	1 ÷ 20	1.8	1.4			
		rigid vert.	1 ÷ 22	1.8	1.4	23 ÷ 40	1.8	1.4
		flexible	1 ÷ 22			23 ÷ 40		
Ø 50mm		rigid horiz.	1 ÷ 10	2.0	1.4			
		rigid vert.	1 ÷ 12	2.0	1.4	13 ÷ 20 21 ÷ 40	2.0	1.4
		flexible	1 ÷ 10			11 ÷ 20 21 ÷ 40		
Ø 100/60		coaxial horiz.	1 ÷ 10	1.0	0.5			
		coaxial vert.	1 ÷ 12	1.0	0.5			

City Open 35 K	gas: G20 - G31 - G230		with factory settings			with modified settings <i>this operation must be performed by authorized technicians</i>		
	Diameter	type	L tot min÷max (m)	90° bend (m)	45° bend (m)	L tot min÷max (m)	90° bend (m)	45° bend (m)
Ø 80mm		rigid horiz.	1 ÷ 58	1.5	0.9			
		rigid vert.	1 ÷ 60	1.5	0.9			
		flexible	1 ÷ 60					
Ø 60mm		rigid horiz.	1 ÷ 18	1.8	1.4			
		rigid vert.	1 ÷ 20	1.8	1.4			
		flexible	1 ÷ 20					
Ø 50mm		rigid horiz.	1 ÷ 8	2.0	1.4			
		rigid vert.	1 ÷ 10	2.0	1.4			
		flexible	1 ÷ 10					
Ø 100/60		coaxial horiz.	1 ÷ 8	1.0	0.5			
		coaxial vert.	1 ÷ 10	1.0	0.5			

Allowed flue types

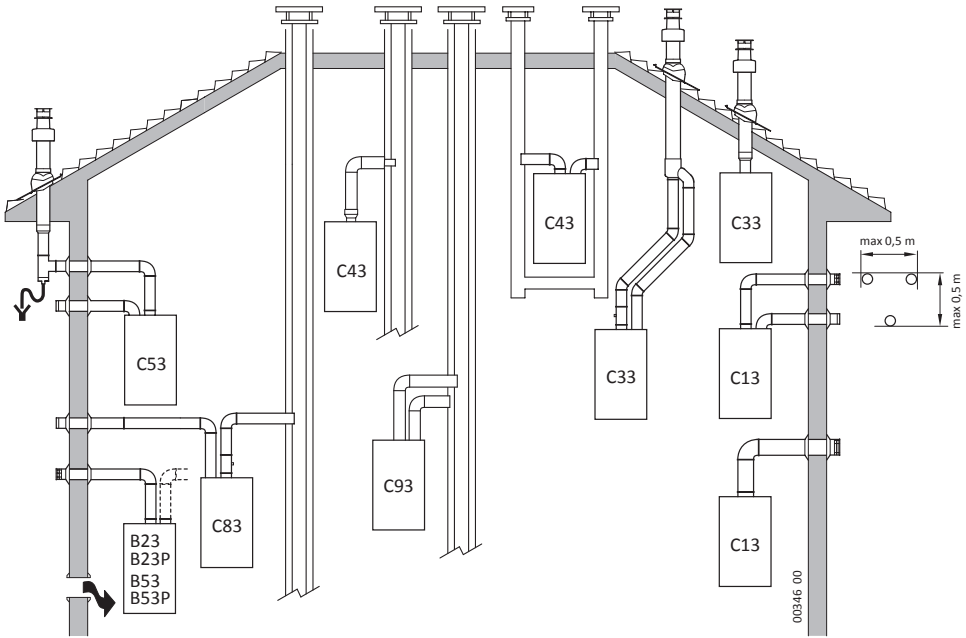

The flue duct and its connection to the chimney should be made in compliance to National and Local Regulation in force. – It's mandatory to use ducts that resist to temperature, condense, mechanical stress, and that are tight. – Not insulated flue ducts potentially lead to dangerous situations.

Air inlet from the room and flue outlet outside.

B23
B23P

REMARK: air inlet opening (6 cm² x kW).

...P: flue system designed to work at positive pressure.

B53
B53P

Same as B23 - B23P but flue system supplied with the appliance.

C13

Coaxial system, to wall. Ducts can start separate from the boiler, but outlets must be coaxial or close each other (within 50 cm) as to be subject to similar wind conditions.

C33

Coaxial system, to roof. Ducts can start separate from the boiler, but outlets must be coaxial or close each other (within 50 cm) as to be subject to similar wind conditions.

C43

Separated outlet and inlet, in shared chimneys subjected to similar wind conditions (natural draught chimney). **The condense flow towards the appliance is not allowed.**

C53

Separated outlet and inlet, to wall or roof or anyway to zones with different pressure.

REMARK: outlet and inlet must never be placed on opposite walls.

C63

Some outlet and inlet types (see "Technical data" on page 50) that can be made by using ducts traded and certified separately.

C83

Outlet in single or shared chimney and inlet from wall. **The condense flow towards the appliance is not allowed.**

C93

Separated outlet and inlet, in shared chimney.

Cavediums dimensions must ensure a minimum interspace between the outer wall of the chimney and the inner wall of cavedium:

- 30 mm for circular section cavediums
- 20 mm for squared section cavediums



WARNING: Hereby described operation can be performed by qualified technicians only.



When regulation/measuring is over, remember to verify the absent of gas leakages. Do not use free flames to detect gas leakages



The gas valve, exception the PIN plug and the upwards connections, works in **NEGATIVE PRESSURE**. We do not recommend to use products for the detection of the gas leakages where not expressly indicated, because these products could penetrate inside the gas valve disturbing its normal functioning.



The siphon is an integral part of the combustion system and it's necessary to check its seal during every technical intervention on the boiler. Verify that both caps (upper and lower) are properly and completely screwed.



Verify that the combustion products do not go out from the outlet of the condense.



The condense syphon trap of the boiler is equipped with a special device which closes when dry. Anyway, the seal is guaranteed only when the syphon trap is filled with liquid. So, at the end of the first firing / commissioning operation, it is recommended to check that the syphon trap contains liquid, e.g. checking that liquid exits the condense drain of the boiler.



Before switching on the boiler, **make sure that the circulating pump is not blocked** due to inactivity: in the middle of the cap there is a hole (should there be a cap, remove it) that gives access to the rotor shaft; **push and turn it using a suitable tool**, usually a "Phillips" screwdriver.



During the commissioning of the **new boiler**, it is necessary to **run the burner for 30 minutes before checking the combustion** because, in that period of time, any residual fabrication vapours could cause false results in the combustion products analysis.

***Remark:** during the first 10 minutes of electrical power supply, the re-ignition delay in heating mode might be nil.*

- *The ignition electronics does several ignition attempts, to avoid blocking the boiler when the ignition fails sporadically.*
- *When the gas supply pipe is filled with air (e.g. in case of new installation) it may be necessary to repeat the ignition cycle several times.*
- *The boiler is factory regulated and tested. Anyway it's advisable, during the commissioning, to check that the regulation is correct.*

First starting up

The first ignition operations consist in verifying the correct installation and functioning, and in the eventual regulations which are necessary:

- ▶ verify that the data of the plate correspond to those of the net supply (electrical, water, gas);
- ▶ verify the absence of the gas leakages from the connections upwards the boiler;
- ▶ verify the proper realization and the efficiency of all the boiler connections (water, gas, heating system and electrical system);

- ▶ verify the presence of the permanent air/ventilation outlets, correctly dimensioned and working, as foreseen by the National and Local laws depending on the appliances installed;
- ▶ verify that the evacuation flue duct corresponds to the National and Local laws and that is in good and efficient conditions;
- ▶ verify the correct functioning of the system of the outlet condense, also in the external parts of the boilers, i.e. the eventual condense collector installed on the flue outlet: verify that the liquid flow is not obstructed and that there are not inlets of gaseous combustion products inside the system itself;
- ▶ verify that the passage of the air burning and the evacuations of the flues and of the condense will be made correctly accordingly to National and Local laws in force;
- ▶ verify that the conditions for the air ventilation are granted, in case of a boiler placed inside a piece of furniture;
- ▶ vent the primary exchanger, proceeding as described in the paragraph "Venting the primary exchanger" on page 30;
- ▶ verify and, if necessary, change the boiler electronic settings to adapt its work to particular system requirements (see "Main boiler parameters (PC)" on page 32);

(i) Before turning on the boiler, verify that the pump is not blocked due to inactivity: unscrew the cap located at the centre of the pump's body, locate the rotor shaft behind the cap and turn it manually using a screwdriver or other suitable tool.

- ▶ verify that the combustion is correctly regulated: go on in this chapter as described in the paragraph "Combustion test" on page 36;

(i) During the first ignition of the brand new boiler, it is necessary that burner works for at least 30 minutes, before performing combustion checks. During this time, the fumes of the eventual residual manufacturing materials are produced, and they could alter the measured values.

- ▶ verify the correct functioning of the boiler in heating and domestic hot water version;
- ▶ fill in the foreseen documentation and leave to the user the copy of his competence.

Maintenance operations

The periodically maintenance operations consist in cleaning the main parts of the boiler, in the further functioning proof (especially those described by the laws in force), and in the eventual regulations, which could be necessary:

- ▶ verify the absence of the gas leakages from the connections upwards the boiler;
- ▶ verify the conformity, efficiency and good conditions of the connections to the boiler (water, gas, heating and electrical system);
- ▶ verify the presence of the permanent air/ventilation outlets, correctly dimensioned and working, as foreseen by the National and Local laws depending on the appliances installed;
- ▶ clean the burner, the exchanger and the funnel of the condense: go on as described in the paragraph "Combustion group cleaning and check" on page 30;
- ▶ check that the internal parts of the boiler are in good condition and clean;

- ▶ verify that the passage of the air burning and the evacuations of the flues and of the condense will be made correctly according to National and Local laws in force;
- ▶ verify the correct functioning of the system of the outlet condense, also in the external parts of the boilers, i.e. the eventual condense collector installed on the flue outlet: verify that the liquid flow is not obstructed and that there are not inlets of gaseous combustion products inside the system itself;
- ▶ verify that the conditions for the air intake are granted, in case of a boiler placed inside a piece of furniture;
- ▶ when prescribed, or if it is necessary (i.e. if you find excessive residual in the combustion group or in the funnel of the condense), verify that the combustion is correctly regulated: go on in this chapter as described in the paragraph "Combustion test" on page 36;
- ▶ verify the correct functioning of the boiler in heating and domestic hot water version;
- ▶ if necessary, vent the primary exchanger, proceeding as described in the paragraph "Venting the primary exchanger" on page 30;
- ▶ fill in the foreseen documentation and leave to the user the copy of his competence.

Access to the inside of the boiler

Note: to remove only the lower closing device, loosen the screws 4.

1. Loosen the two fastening screws 1 of the insulating covering located on the lower side near the wall;
2. push the insulating covering upwards and remove it;
3. once all the operations requiring access to inner parts are completed, close the boiler by performing the operations in reverse order, making sure to engage, on both sides, the tabs of the insulating covering 3 and those of the frame 2 (the upper cover is not shown in the figure so that tabs are visible).

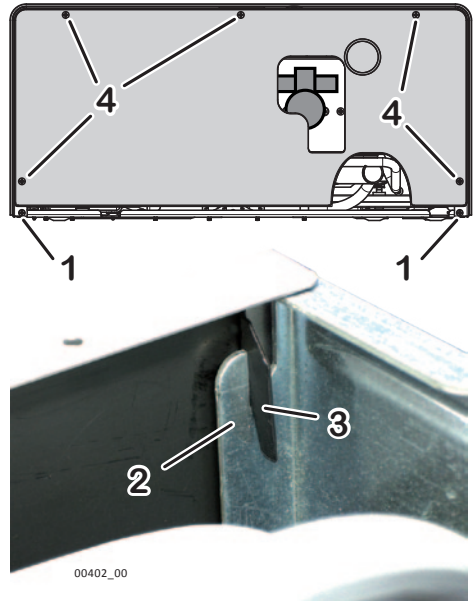

Venting the primary exchanger

When commissioning the boiler, we recommend to check that there is no air in the primary circuit of the combustion unit. Do this operation also during the combustion unit cleaning, if you hear the typical air bubble noise.

- ▶ Locate the **combustion unit manual venting valve** (item 9 in the following picture) and, to avoid wetting the boiler inside, insert a length of flexible hose, with suitable diameter, on its fitting, then direct the other end towards a drain (or a container to collect the anti-freeze solution);

Note: *alternatively, after making sure that it is allowed, remove tube 17 from the coupling 21 of the intake/outlet flange and insert it into the hose connector of the manual valve 9. The funnel will drain the water (but the drained liquid cannot be recovered).*

- ▶ start the "circuit venting" mode by activating the **Parameter 07** (see "Main boiler parameters (PC)" on page 32);
- ▶ slowly open the venting valve 9 (the automatic system filling could activate);
- ▶ when no more air comes out from the venting valve 9, close the valve and reset the **parameter 07** to 0;
- ▶ restore the concentration of additive liquid, if any.

Combustion group cleaning and check

 **Switch off the boiler and disconnect it from the electrical supply.**

 **Be sure that the parts are not hot and eventually wait the time necessary to cool them;**

 **Because some contacts with the fine dust and acid condense may occur, we recommend to wear the proper devices for the personal protection (i.e. glasses, gloves, masque)**

 **Warning:** do not wash or damage the insulating coverings inside the combustion chamber.

 **The replacement of gasket on the ends of the gas pipe 6 is mandatory. Please get the original spares.**

- ▶ Open the sealed chamber;
- ▶ disconnect the two connectors 2 from the fan;
- ▶ disconnect the connector 18 from the ignition/detection electrode 19.
Attention: do not dismantle the electrode from the combustion group;

- ▶ remove the fastening clip 3; unscrew the nut 7 which fixes the gas pipe 6 to the gas valve; pull out the gas pipe 6 from the fan/air-gas-mixer assembly;

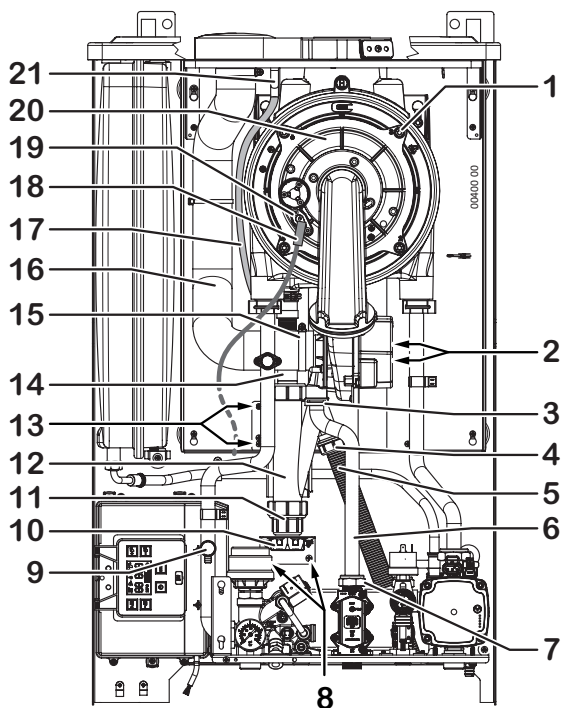

- ▶ loosen the clamp **15** and pull the flexible air intake hose **16** out from the fan;
- ▶ unscrew, following the stamped sequence, the four nuts **1** which fix the burner group **20** (composed of fan, hose and burner) to the primary exchanger. Remove the burner group;

(i) Do not disassemble the burner group and do not dismount the ceramic fibre plate from the bottom of the exchanger.

- ▶ check the integrity of the insulating coverings inside the combustion chamber;
- ▶ on the burner cover, check the integrity of the fireproof fibre gasket and of the silicone rubber one;
- ▶ check that the burner do not present deposits, foulings or excessive oxidations and that all the holes are free;
- ▶ clean the cylinder of the burner **ONLY IF IT IS NECESSARY** and only **DRY**, through a **NOT METALLIC** brush, with movements on the burner's axis, from cover outwards;
- ▶ clean softly the burner electrode, and check that the minimum space is 3.4mm to 5.4mm;

(i) Do not damage the insulating coverings inside the combustion chamber and don't deform the holes of the burner. If the burner works correctly, it will be of black colour but clean or in any case with few deposits, not scaled and easy to remove.

- ▶ find the lower cap **11** of the funnel and estimate through its transparency, without removing it, the quantity of accumulated residues;

Note: *an excessive quantity of residues in the cap **10** (up to the thread and beyond) indicates a malfunction or, in any case, it is not normal. In this case, identify the causes of the problem and solve it.*

▶ **clean the primary exchanger:**

- prior to brushing the exchanger's coils, carefully remove, by a powerful vacuum cleaner, the solid residuals of combustion; don't use air jets now;
- then clean the primary exchanger coils by a **NOT METALLIC** brush and remove the residuals again by using the vacuum cleaner;
- if necessary, clean the coils using compressed air;
- from the front opening of the burner unit, pour an appropriate quantity of water (for example with a glass) into the combustion unit, in order to wash away the residues, which will move into the funnel.

▶ **Remove and wash the funnel:**

- loosen the screws **13** fastening the bracket to the funnel support **12**;
 - loosen the ring nut **4** and extract from it the corrugated condensate drain pipe **5**;
 - remove the tube **17** (intake flange water discharge) of the funnel coupling **12**;
 - pull the lower part of the funnel **12** toward yourself, beyond the space occupied by the anti-freeze heater bracket **10** and then downwards. Remove the funnel from hose **14** (if necessary, move away the anti-freeze heater bracket **10** after loosening the screws **8**);
 - disassemble and thoroughly wash all the funnel parts, then reassemble it;
- ▶ reassemble by operating in the reverse order, checking the parts for damage or wear;
- ▶ check combustion (see "Combustion test" on page 36).

PCB parameters settings (technician menu)

Boiler parameter setting is to be carried out by technical personnel only. The technical menu is accessible from the Service Control panel through a specific key combination owned by the technician.

A few of these settings allow to optimise and tailor the boiler working, while a few others allow to set the boiler during maintenance operation.

On the Service Control Panel display, the number of the selected parameter is shown by the 2-digit numeric indicator on the left. All parameters have a value, shown by the 3-digit numeric indicator on the right, which can be adjusted within a certain range depending on the parameter itself.

 In case of PCB replacing, check all of the parameter settings otherwise set them properly. Please, do not modify any firm setting if this is not required.

Main boiler parameters (PC)

The parameters listed in the following table are limited to those described in this handbook. The complete parameter list is available in the documentation for the technician.

Parameter	Adj. range (fact. set.) and values	Description
01	0...2 (0)	Type of GAS supply
	0	for Natural Gas (G20) supply
	1	for Commercial Propane (G31) supply
	2	for Air/Propane (G230) supply
	To change the type of gas supply, it is necessary to follow the complete instructions described in the paragraph "Gas conversion" on page 40.	
02	0; 1 (0)	Heating flow temperature setting range
	0	Normal setting, suitable for plants with radiators. This allows the user to adjust the system flow temperature, by acting on the Remote Control, within the high-temperature range
	1	Reduced setting, suitable for low temperature plants. This allows the user to adjust the system flow temperature, by acting on the Remote Control, within the low-temperature range.
<i>Remark: in case of mixed plants (with high and low temperature) thanks to optional kit, set low range (value 1) (please also refer to documentation provided with the kit).</i>		
03	—	It indicates the CH boiler power during the soft ignition phase. We recommend to leave the factory setting unchanged.
04	0...99 (*)	It indicates the CH boiler power according to the maximum nominal boiler power.
<i>Remark (*): The factory setting depends on the model: see "Power adjustment tables" on page 37.</i>		
See details in "Max heating power adjustment" on page 37.		

Parameter	Adj. range (fact. set.) and values	Description
05	0...2 (0)	Pump functioning mode during heating working
	0	intermittent for normal applications (with eventual delay defined by parameter 06)
	1	always on (to fit the needs of particular plants)
	2	always off (use only when external pumps are foreseen). <i>Remark: The pump will be anyway activated in all other circumstances, e.g. during the DHW functioning or for anti-freezing or anti-lockout functions.</i>
06	0...15 (3)	Value in minutes. Delay of boiler re-ignition after set Central Heating temperature has been reached. (This parameter works only if par. 05 = 0)
07	0...3 (0)	Auxiliary maintenance functions
	0	Disabled - normal operation of the boiler (Remember to set this value to 0 at the end of work)
	1	function Bleeding on heating side - boiler puts 3-way valve on the heating side and pump is continuously powered
	2	function Bleeding on DHW side - boiler puts 3-way valve on the DHW side and pump is continuously powered
	3	function Bleeding both Heating and DHW side - boiler cyclically moves the 3-way valve on heating and DHW sides, and pump is continuously powered <i>Remark: Auxiliary maintenance functions stay active for about 15 minutes, then the parameter is automatically set back to 0. To stop the function manually, set the value to 0 or quit the Technical Menu.</i>
08	0...2 (1)	Primary circuit working temperatures during DHW demand
	0	dynamics - Do not use in this type of boiler (only for models with flow meter instead of flow switch)
	1	fixed - burner OFF at 75°C and burner ON at 65°C
	2	linked to DHW SET: Burner OFF when DHW temperature + 3 ° C and burner ON when DHW temperature + 2 ° C
12	0...2 (0)	Chimney-sweeper" function: burner ignition, not modulated, to allow the combustion check. For deeper details see paragraph "Combustion test" on page 36.
	0	burner off - normal boiler work (remember to reset this parameter to value 0)
	1	burner ignition at maximum output
	2	burner ignition at minimum output <i>Remark: During this phase, the delay between burner ignitions is zero, so if flow temperature is close to maximum, frequent re-ignitions of the burner could take place.</i>

Parameter	Adj. range (fact. set.) and values	Description
17	20...80	TA2 input setting (flow temperature during a CH request from the Secondary Room Thermostat only) <i>The boiler can manage a secondary room thermostat installed in a zone that must be heated with a different typology compared to the one where the primary room thermostat (or the original Remote Control) is installed. It's possible to foresee (with suitable hydraulic system solutions to distribute the heating to the various zones) a zone with a low temperature heating system (e.g. the primary one, controlled by the primary room thermostat or the original Remote Control) and one with radiators (controlled by the room thermostat TA2). The advantage of this management is that, when only the low temperature system requires heating, the boiler can work in low temperature and therefore condensing, with all the consequent advantages. Please note that the adjustment range is unique and it's extended to both the temperature typologies but, being a technical parameter, there's no possibility for the user to adjust (wrongly) the <u>system flow temperature</u> of the zone managed by TA2. Of course, the user will be able to adjust the <u>room temperature</u> of the secondary zone, by acting on TA2 itself.</i>
22	0; 5...120 (0)	Enabling of Safety Thermostat on floor plant (on AUX input - see also parameter 46) and delay of its operating <i>Remark: avoid selecting values outside of the range described and correct if necessary.</i>
	0	Disabled - the component is not connected to AUX input
	5...120	Minutes of delay between the thermostat activation (open contact) and boiler block. <i>If the thermostat deactivates, the time count resets.</i>
33	0...3 (0)	Pump head modulation on Heating demand
	0	Modulation disabled - Pump is always operating at maximum power
	1	Modulation with fixed ΔT - once chosen ΔT with Parameter 34, pump increase or decrease its power in order to keep ΔT as much stable as it can, no matter which Heating demand is present (TA1 or TA2).
	2	Modulation with dynamic ΔT - Once chosen ΔT with Parameter 34, pump increase or decrease its power in order to keep ΔT as much stable as it can during high Temperature demand. If a low temperature demand is present, pump is working at the same way, but its ΔT target is now half of Par 34.
	3	Modulation based on boiler power output - Pump Power is proportional to Boiler Power thanks to optimized algorithm on main PCB.
34	0...3 (0)	ΔT setting for Pump modulating <i>(only if par. 33 is not 0)</i>
	0	$\Delta T = 20^{\circ}\text{C}$
	1	$\Delta T = 15^{\circ}\text{C}$
	2	$\Delta T = 10^{\circ}\text{C}$
	3	$\Delta T = 5^{\circ}\text{C}$
Remark: When chosen Modulation with fixed ΔT (param. 33=1), it is advised to select 0 or 1 with High Temperature plants and 2 or 3 with low temperature ones. In the case of mixed plant (high and low temperature), Modulation with dynamic ΔT (param. 33=2) is advised because chosen value on Par 34 is used for high temperature demand and half value (param. 34/2) is dynamically used for low temperature demand.		

Parameter	Adj. range (fact. set.) and values	Description
35	65...99 (mod. 25: 88) (mod. 30: 88)	Maximum power of <i>modulating</i> pump. It is recommended not to change factory setting. While minimum pump power is fixed at 65% of the nominal maximum, the maximum pump power can be reduced to solve particular installation (eg. plant noise), provided that the pump modulation is enabled. In fact, if the modulation is disabled (par. 33=0) this parameter is irrelevant.
	0	ON-OFF Pressure switch (setting for this boiler) - The boiler reads open contact = low pressure and closed contact = pressure OK . The system pressure and relevant alarms and signals therefore depend on the setting and hysteresis of the pressure switch.
36	0...4 (0)	Selection of system pressure detection type
	1...4	Analog transducer (NOT for this boiler) - The boiler gets an analog signal from the transducer and will consider it in a range of min. - max. pressure depending on the value: 1: 0.4 bar - 0.7 bar; 2: 0.5 bar - 1.0 bar; 3: 0.8 bar - 1.2 bar; 4: 0.9 bar - 1.4 bar
37	0; 1...10 (4)	Enabling and timing of the automatic system filling
	0	Disabled - for models without automatic system filling
46	1...10	Maximum filling time (minutes) that, once elapsed without reaching the nominal system pressure: the boiler gets blocked; the filling is aborted; the alarm E19 is shown
	0	Safety thermostat of Floor plant - When thermostat opens (open circuit), boiler blocks and shows a specific alarm. Both this parameter and no. 22 are factory set to 0 so, practically, AUX input is ignored.
49	1	DHW Storage tank thermostat - Don't use because this function is not allowed on this boiler. Information purpose only: in models with DHW storage, with closed circuit it forces the storage preparation (heating).
	2	Room Thermostat 3 - with closed circuit, this contact activates heating demand at the same temperature of TA1 or Remote control.
49	0...20 (0)	Chooses the type of combustion calibration. <i>Remark: avoid selecting values outside of the range described and correct if necessary.</i>
	0	Manual (CO ₂ adjustment)
	5	Automatic (combustion system preset)

Combustion test

(i) if **burner and exchanger cleaning** is foreseen, carry it out before testing the combustion (see “Combustion group cleaning and check” on page 30).

To perform the test you need a **flue analyser, correctly calibrated** (in the condensing boiler, the precision and the correctness of the measures is particularly important). Then, through a suitable function on the panel, we ignite the burner, first with a reduced flow and then at the maximum flow, doing the measure and adjustments in both conditions. Proceed as follows:

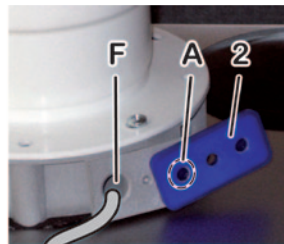
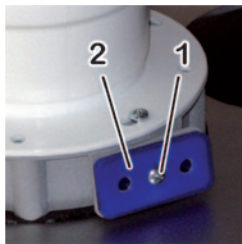

1. the boiler should be electrically powered and set in **OFF**. If necessary, use the button  on the Service Control Panel (only **OFF** has to be shown on the display);
2. on the flue flange, unscrew the screw **1** and move the tapping insert **2** in such a way to tap the intake plug **A** only; insert the analyser probe in the flue plug **F**, taking care of the seal of the connection;

Remark: The sensor placed at the top of the probe must be placed as possible in the centre of the flow outlet: we advise you to insert well the probe and so to extract it of 3 cm. Insert the probe so that the protection bow of the sensor, placed at the top, is transversal (the flow must pass through it and directly touch the sensor).

3. set the boiler in a status different from **OFF** (e.g. in Winter mode);
4. generate a heating request by activating the room thermostat or by opening a DHW faucet (consistent with the boiler's status).

(i) Be sure that the heat produced by the boiler can be eliminated by the heating system (through the radiators and/or radiant panels/floor systems) or by the water.

5. activate the boiler to its **minimum output not modulated (Qr)**, by entering the technician menu and setting the parameter **12** to value **2** (see also “PCB parameters settings (technician menu)” on page 32);
6. Wait for the boiler to stabilize (about 5 minutes) then check, referring to the table, that the measured CO₂ value at **Qr** is within the allowed range;

Mod.	Heat input	Natural gas G20		Commercial Propane G31		Air/Propane G230	
		CO ₂ at Qn and ignition (%)	CO ₂ at Qr (%)	CO ₂ at Qn and ignition (%)	CO ₂ at Qr (%)	CO ₂ at Qn and ignition (%)	CO ₂ at Qr (%)
25	Nominal value	9.1	9.3	10.1	10.1	10.4	9.8
35	Allowed range	8.2...9.7	8.4...9.6	9.1...11.1	9.0...11.0	9.4...11.0	9.0...10.8

7. don't quit the technical menu and activate the boiler to its **maximum output not modulated (Qn)**, changing the value of the parameter **12** to **1**, wait for the boiler to stabilize and check, referring to the table, that the measured CO₂ value at **Qn** is within the allowed range;



8. if one or more CO₂ values was outside allowed ranges, carry out the MANUAL combustion calibration (see "Combustion calibration" on page 38);
 - if the manual calibration doesn't allow to adjust the CO₂ to normal values, carry out an AUTOMATIC calibration (remove the analyser during this operation) and then do a manual calibration again, measuring and adjusting the CO₂. If the problem persists, a fault in some component of the combustion system should be assumed.
9. quit the technical menu and set the boiler to OFF mode;



IMPORTANT: at the end of the check or the adjustments, it is INDISPENSABLE:

- close the flue plugs used, by restoring the tapping insert **2** and the screw **1**, caring that the plastic surface of the flange is not damaged or worn;
- check the correct flue system tightness, especially the tightness of the tapping insert **2**.

Power adjustment tables

	HEAT INPUT		Value of par. 4
	kW	kcal/h	
City Open 25 K	MIN. 2.50	2150	00
	4.61	3965	10
	6.75	5805	20
	9.25	7955	30
	11,87	10208	40
	14,14	12160	50
	16,50	14190	60
	18,75	16125	70
	20.00	17200	78* (Qn)
	20,75	17845	80
	23,20	19952	90
	MAX. 25.00	21500	99 (Qnw)

	HEAT INPUT		Value of par. 4
	kW	kcal/h	
City Open 35 K	MIN. 3.5	3010	00
	5.9	5117	10
	9.1	7800	20
	11.8	10148	30
	14.7	12625	40
	17.5	15016	50
	20.4	17578	60
	23.3	20029	70
	26.2	22558	80
	28.0	24080	83* (Qn)
	29.1	24992	90
	MAX. 33.2	28552	99 (Qnw)

* Factory setting of the Maximum Power Input in heating mode (Qn)



The factory setting shown in the table corresponds to the Maximum Power Input in heating mode (Qn) to which the boiler is homologated. **DO NOT set higher values.**

Max heating power adjustment

The maximum heating power output must be set in accordance with the system requirements (stated in the project) by using the parameter **04** (see page 32) with reference to the "Power adjustment tables" on page 37. The boiler is factory preset with a standard value, highlighted in the relevant table.

1. Get information about the maximum heating power requirement of the heating system (reported on the project documentation of the system itself);
2. ensure that there are NOT domestic hot water requests (no open taps) and that the heat produced by the boiler can be drained by the heating system;
3. enter the technician menu (see "PCB parameters settings (technician menu)" on page 32), select the parameter **04** and get ready to change its value. The burner ignites;
4. set the parameter **04** to the value that corresponds to the required power input (refer to the "Power adjustment tables" on page 37); **do NOT set the parameter 04 to values above the factory setting.**

5. To switch the burner off, quit the technician menu (see also "PCB parameters settings (technician menu)" on page 32). The boiler switches to OFF mode.

The MAX power for the heating system is adjusted now.

Combustion calibration

Boiler is able to self-calibrate combustion in order to obtain correct CO₂ values on 3 different boiler power (minimum, average, maximum); moreover boiler keeps on checking combustion and makes little variations for always getting as better combustion as it can.

Boiler Calibration can be activated by a particular buttons sequence on the Service Control Panel (known by the Technician) and it has 2 following options depending on the parameter 49 (see page 35):

- **AUTOMATIC:** this calibration is made during boiler production; on the field it should not be done **unless components linked to combustion have been replaced** (main PCB, Gas Valve, Fan, Primary exchanger, Burner, Electrode...). At the end of this procedure it is not allowed any change at values stored but boiler can work property with correct combustion values (even if they have to be checked with relevant instruments)



During Combustion Calibration, flues tester should not be used because during this procedure, boiler can produce more than CO₂ needed and test result, in this condition, could not be accurate and truthfulness. **Combustion check with flues tester must be done after Calibration and not during it.**

- **MANUAL:** this calibration checks again the "Automatic calibration" done previously in production and allow the technician to modify a bit the results: +o- 3 steps where CO₂ % is changing about +o-0.6%; this means that every step changes +o-0.2% CO₂). Manual Calibration should be used when technician would like to make a more accurate calibration.
- ▶ Be sure that Parameter 49 is set to Combustion Calibration needed (AUTOMATIC or MANUAL)
 - ▶ activate the Combustion Calibration with relevant buttons sequences on the Service Control Panel (known by Technician);
 - ▶ the display on the Service Control Panel shows the writing **MANU** (or **AUTO** if the automatic calibration is deemed necessary);

Remark: in any moment, the calibration can be stopped by pressing the button , but the operation must be restarted and carried out completely in order to store the reference values in the system.

- ▶ once the ignition phase is finished, the system sweeps the three characteristic points: minimum, ignition and maximum, and displaying, respectively, **LO**, **ME** and **HI**.
- ▶ afterwards, in case of **MANUal** calibration, the CO₂ values can be adjusted:
 - select one of the phases **LO**, **ME** or **HI** by the buttons **+ .III** and **- .III** and wait for the stabilization of the CO₂ value on the analyser;
 - adjust the CO₂ value, if necessary, by the buttons **+ F** and **- F**;
 - proceed in the same way for the other two phases (eventually exclude the **ME**).
- ▶ Store the set by keeping the button  pressed for at least 2 seconds.
- ▶ If the value of the Parameter 49 has been modified to carry out the AUTO calibration, restore it to factory setting (see page 35).

Accessing the main board

The main PCB has no hardware adjustment devices onboard, so no access to it is required, except in case of cabling check or replacement of the board itself. Proceed as follows:



Cut off the electrical supply to the boiler. Restore the supply after having closed, and put back in its position, the electric box / service control panel.

- ▶ loosen the four screws **2** and the screw **3**;
 - should it be difficult to access the screw **3**, disengage the electric box from the frame, loosening the screw **1** and the screws **6** and lifting the electric box to disengage it;
- ▶ separate the front part of the electric box **5** (with the service control panel) from the rear side;
- ▶ tilt the front part of the electric box **5** towards the boiler inner side and engage the heads of the screws **4** to the slots **7**. The electric box will be facing towards you, allowing you to operate on it;
- ▶ reassemble by operating in the reverse order and direction.



An incorrect or incomplete closing of the control panel will void the IP protection degree of the appliance. Make sure that all the closing elements of the electric box are correctly refitted and that cables pass into the relevant housings without being pinched.

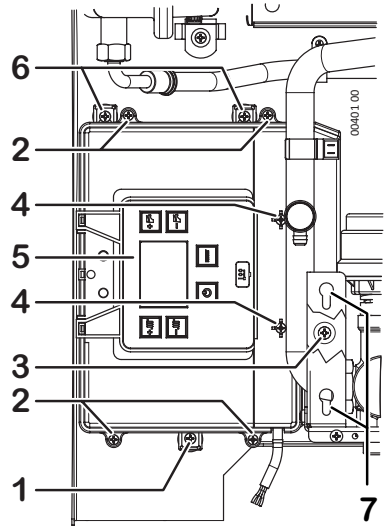

Main board replacement

Carefully follow the instructions included in the spare board kit.

Board configuration codes

Model	Gas G20 (1)	Conv. to G31 (2)	Conv. to G230 (2)
City Open 25 K	30140	31140	32140
City Open 35 K	30340	31340	32340

(1) Factory preset; code written on the sticker on the electronic box

(2) Code that will appear on the display (for some seconds at the moment of the electrical supply) if the Parameter 01 has been changed because of gas conversion.

WARNING! Always check the updated code on the sticker applied to the electric box.

Gas conversion





ATTENTION: the operations described below must be carried out only by qualified personnel.

This boiler is designed and prepared to be supplied with Natural Gas G20 (Methane). It can be set, just by means of electronic settings, but **always by a qualified technician, to operate with Commercial Propane G31 or Air/Propane G230, for which it is absolutely necessary to install a pressure reducer upstream the boiler.**



Using Propane gas G31, it is absolutely necessary to install a pressure reducer upstream the boiler. Failure to do this, the gas valve of the boiler will get damaged. The inlet gas pressure must be compliant with the one specified in "Technical data" on page 50.

1. The boiler must be electrically powered, then it must be set to Winter Mode by means of the button  of the Service Control panel (symbols  and  visible);

*Note: technically, any mode other than OFF is suitable, but we recommend **not** to select Summer mode in order to keep the Remote Control disabled during the intervention.*

2. set the parameter **01** (see "PCB parameters settings (technician menu)" on page 32) on the required gas kind the boiler is required to work with:
 - **0 = Natural gas (G20),**
 - **1 = Propane (G31)**
 - **2 = Air/Propane (G230)**
3. ensure that the inlet gas pressure complies with the required nominal pressure (see "Technical data" on page 50) and that the gas flow is sufficient to guarantee the appliance correct work with burner ON;
4. we suggest to **clean the burner and exchanger** as described in the paragraph "Combustion group cleaning and check" on page 30 (*except* for the case of first ignition, new burner).
5. carry out the **AUTOMATIC combustion calibration** - see paragraph "Combustion calibration" on page 38 ;
6. carry out the **combustion test** - see paragraph "Combustion test" on page 36 ;
7. apply the label indicating the type of gas (provided with the kit) in the area provided on the "WARNING" plate inside the boiler; besides, write down the new configuration code of the main board (see table "Board configuration codes" on page 39)



In the case of liquid gas fuel, it is important that **the boiler be exclusively fuelled with commercial Propane G31** and not with Butane G30. For this reason, we recommend that **the supplier of the fuel be informed, for example, by applying a suitable warning on the gas tank** or in its immediate vicinity, **so that it is visible** to the employee at the time it is being filled.

Draining the heating system

When it is necessary to drain the heating system, proceed as described here below:



Cut off the supply voltage to the boiler, for safety reasons, but also to prevent the activation of the automatic system of the filling system.

- ▶ remove the lower closure of the boiler or the complete insulating covering (see "Access to the inside of the boiler" on page 29)
- ▶ Connect a rubber pipe to the draining tap terminal **1** ;
- ▶ put the other end of the pipe in a suitable drain or sink;
- ▶ open the draining tap by turning the nut **2** counterclockwise, using a suitable spanner;
- ▶ when the pressure is COMPLETELY drained, it's possible to open the radiators venting valves, to allow the air inlet. The complete system drain is possible only draining the liquid from the lowest point of the system itself.

Remark: The complete system draining can be achieved only by draining the system from its lowest point.

- ▶ when everything is over, close taps (turning the nut **2** clockwise) and air vents.



In the primary exchanger a certain quantity of water of the heating system remains. If you want to remove the boiler from the wall, we advice you to close with plugs the hydraulic inlet/outlet heating system connections.

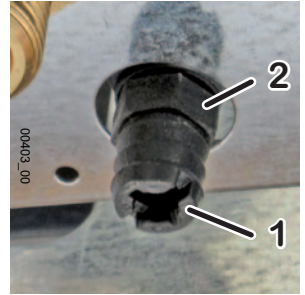
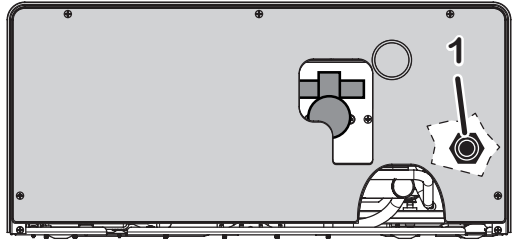

Pump settings

The circulating pump is already set by the factory for all normal boiler applications. It can be adjusted, by means of suitable parameters (see page 34) to optimise the system operation or reduce any noise caused by a too fast circulation. The head curve is shown on page 12.

Alarms - boiler block







Following a malfunction, the boiler can lockout and show a particular signal, **RESET** or **SERVICE** on the display, with an alarm code "E...". In the following table, all the alarm signals are listed, their most probable causes and the suggested solutions. Generally:









- **RESET** identifies those **alarms the user can restore** by pressing the **RESET** button. It normally **blinks**, but after 5 reset actions in 24 hours the action on the **RESET** button has no more effect. *To have 5 further reset possibilities, it's possible to switch off the electrical supply to the boiler for 30 seconds, by using the purposed external switch, even if this work-around won't solve the problem and it will be necessary to call the Service Centre;*
- **SERVICE** identifies those **alarms the user can not restore**, as they are generated by the diagnostic system when a component has been detected as faulty. *The user is allowed to switch off the*





electrical supply to the boiler for 30 seconds, by using the purposed external switch, but should the alarm happen again, it will be necessary to call the Service Centre.













Operations accompanied by the symbol  are always reserved to the Technician. Operations with grey background are reserved to the Technician.









Signal	Probable causes	Suggested solutions
RESET E01	Boiler just installed (air mixed to gas).	<p>Retry the ignition several times: use the RESET button.</p> <p><i>When the 5 reset possibilities are over, to have 5 more, it's possible to switch off the electrical supply to the boiler for 30 seconds, by using the purposed external switch.</i></p>
	The flame has extinguished or it did not ignite	<p>Restore the boiler function by using the RESET button.</p> <p> In case of frequent blocks, verify the correct combustion, the good state and the cleaning of the burner.</p>
	 Incorrect combustion / flame detachment from the burner	<p>Check that the Intake/Outlet Ducts and the respective terminals are clean and in good condition, and that there are no leaks in them. During the installation, respect the regulation prescriptions, the slopes and the lengths (see "Flue systems" on page 21).</p> <p><i>Note for the TECHNICIAN: The burner flame is not detected by the control electronics because it has not turned on or it has suddenly turned off, or it has detached from the burner, because of an incorrect combustion. This can be due, in example, to combustion product reflow into intake duct, leaks in intake/outlet ducts or errors in sizing of ducts (ducts length out of the allowed range, and/or wrong use of the reducer on boiler's outlet).</i></p>
 Condensate drain problem	<p>Verify and restore the correct condensate drain.</p> <p> Warning! DO NOT open the combustion assembly before having cleared the drain and removed the condensate accumulated in the combustion chamber. <i>This alarm is caused by the condensate that, after having partially filled the combustion chamber, reaches the detection electrode and inhibits the detection of the flame ionisation.</i></p> <p>Then, check the combustion and verify that the burner is clean and in good conditions.</p>	
RESET E02	the boiler has overheated and the Safety Thermostat has triggered	<p>Restore the boiler function by using the RESET button. If necessary, wait at least 20-30 minutes (to make the boiler cool) and try again. If the lockout persists or reappears, call the Service Centre.</p>
		<p> Verify the safety thermostat functionality. Detect the causes of the overheating, e.g. an insufficient circulation in the primary circuit; max gas pressure out of the limits or maximum heating power excessive for the heating system size.</p>
SERVICE E03	 The flue overheat thermal fuse has triggered (flue on boiler outlet too hot)	<p>Solve the problem that caused the overheating of the flue, then replace the flue thermal fuse.</p>
		<p><i>Note for the TECHNICIAN: the flue thermal fuse preserves the flue ducts (that are made with Polypropylene, a material suitable to the condensate acidity) from the high temperatures, that could lead to their fusion or deformation. The triggering of this device consists in its blowing and therefore it must be replaced.</i></p>

Signal	Probable causes	Suggested solutions
RESET E04 	Combustion check anomaly. Gas valve is supplied without flame presence.	User: Try only one boiler reset by using the RESET button. If the lockout persists or reappears, call the Service Centre for required procedure
SERVICE E05 	Failure to the system flow temperature probe.	Check the cabling of the system flow temperature probe. Replacement of the system flow temperature probe.
SERVICE E06 	Failure to the DHW temperature probe.	Check the cabling of the DHW temperature probe. Replacement of the DHW temperature probe.
SERVICE E07 	Max number of alarms/blocks, of any kind, reached.	Boiler has blocked and has been reset many times. This proves that the boiler has a problem, so call the Service Centre. User: To attempt an interim restore, disconnect the electrical supply to the boiler by operating the suitable external bipolar switch, then connect it again after a few minutes.
SERVICE E08 	Max number of boiler alarms reached for no flame detection.	Combustion or burner has a recursive problem. Flame detection has been lost (with boiler block) for many times in a row. User: Try a boiler reset by using the RESET button. If the lockout persists or reappears, call the Service Centre.
SERVICE E09	Periodical Service maintenance	Call Service Technician for planned maintenance operations. <i>Pushing RESET, User can cancel this for 3 times. After that the signal remain on display. Even with this signal present, boiler is still working properly.</i>
RESET E10	Insufficient system pressure and wrong setting of parameters 37 (and 36).	 Check that parameters 36 and 37 are correctly set (see "Main boiler parameters (PC)" on page 32). During reactivation, therefore, a filling cycle (ref. "E18") is normal. <i>Remark: Consider that the pressure, in normal conditions, should not decrease with the progress of the time. If this happens, there is probably a loss in the heating system. Sometimes the loss is so small that it doesn't leave evident signs, but with the progress of the time it can cause the decreasing of the pressure. Also the opening of the manual venting taps of radiators (intentional or unintentional) makes the pressure decrease. Check that this doesn't happen.</i>
SERVICE E13 	Gas modulator not connected.	Check the cabling of the gas valve's modulation command. Gas valve electrical circuit failure. Check/replace.
SERVICE E15 	Failure to the heating system return temperature probe.	Check the cabling of the system return temperature probe. Replacement of the system return temperature probe.
RESET E16 	Fan failure. The burner fan is stopped or rotates at an incorrect speed.	User: Try a boiler reset by using the RESET button. If the lockout persists or reappears, call the Service Centre. Check the burner fan functionality. Replace it if necessary.

Signal	Probable causes	Suggested solutions
E17 	<p>Pushbutton failure on the Service Control Panel.</p> <p>The electronic has detected the actuation of a pushbutton for more than 30 seconds.</p>	<p>Check the Service Control Panel (see "The Service Control Panel" on page 55) for jammed pushbuttons that remain pressed. Disconnect the electrical supply to the boiler by operating the suitable external bipolar switch, then connect it again after a few minutes.</p> <p>Remove the main PCB and clean, using suitable products, the rubber keyboard and pushbuttons' contact pads both on buttons and on the PCB.</p> <p>Replace damaged parts if necessary.</p>
RESET E18	Automatic filling in progress	The CH system water pressure was insufficient for the normal functioning so the boiler started the automatic water filling in the CH system. Once the right pressure is achieved, the error code automatically disappears and the boiler restart the normal function.
SERVICE E19	Automatic filling in not completed after 4 minutes.	<p>During the automatic filling in (see "E18") the system pressure does not achieve the right value within the preset time. Maybe due to:</p> <ul style="list-style-type: none"> • inlet water pressure from the net is not sufficient (see "Technical data" on page 50); • inlet water cannot enter the boiler for likely closed tap installed in the inlet way. <p>Try to restart the boiler by powering the boiler off for 30 second and the power that on again from the bipolar switch.</p> <div style="background-color: #e0e0e0; padding: 5px;"> <p> Filling in valve is blocked/broken/or it is not electrically supplied • Inlet filters are clogged • Big quantity of scale in the water • Big loss of water in the CH system.</p> </div>
SERVICE E21	<p>Low system pressure</p> <p><i>(after a preset number of filling cycles have been done)</i></p>	<p>The boilers has filled in water (see "E18") for three times within the latest 24 hours, but now the system pressure has dropped again. Likely there is a leak of water in the CH system.</p> <p>Try to restart the boiler by powering the boiler off for 30 second and the power that on again from the bipolar switch. <i>During the power-up, an automatic filling in cycle could start (see "E18").</i></p> <p><i>Note: it is possible to experience this alarm code during the first filling in when the boiler is just installed due to bleeding of air from the system. For this reason, at the first time the boiler gets electrically supplied, the number of fillings allowed before showing the error code are 5 and not 3 for the first 24 hours after the installation.</i></p> <p><i>Remark: Consider that the pressure, in normal conditions, should not decrease with the progress of the time. If this happens, there is probably a leak in the heating system. Sometimes the leak is so small that it doesn't leave evident signs, but with the progress of the time it can cause the decreasing of the pressure. Also the opening of the manual venting taps of radiators (intentional or unintentional) makes the pressure decrease. Check that this doesn't happen.</i></p> <div style="background-color: #e0e0e0; padding: 5px;"> <p> Leak in the heating system.</p> </div>
SERVICE E22 	PCB Software Error.	Call Service Centre for required procedure.

Signal	Probable causes	Suggested solutions
SERVICE E23 	Inlet electrical frequency not correct (50 Hz ± 1 Hz).	Call Service Centre for checking electric inlet signal.
RESET E24 	Floor heating system safety thermostat triggering: <ul style="list-style-type: none"> ▶ system flow temperature too high; ▶ floor heating system defective, faulty or malfunctioning. 	<p>The floor heating system and the floor cladding can be damaged by temperature shocks, so a good quality system includes one or more safety thermostats that, if necessary, trigger and lock the boiler.</p> <p>Try a boiler reset by using the RESET button (eventually wait for a period that allows to cool the system and restore the thermostat). If the lockout persists or reappears, call the Service Centre</p> <p><i>Remark: This alarm is in relationship with parameters 22 and 46 (paragraph "Main boiler parameters (PC)" on page 32. When this alarm is active, the hot water production is locked too.</i></p> <p> If any floor heating system was installed, check the correct setting of parameter 22 (see page 34).</p> <p>If the floor heating system is installed, check the system flow temperatures on the boiler and on the low temperature system kits (if installed). Replace the faulty or out-of-tolerance thermostats. Check the correct positioning of the thermostats on the system (see "Floor heating system" on page 13). Consider if the delay on the thermostat's triggering is too low and eventually, carefully, adjust it by increasing the value of parameter 22.</p>
SERVICE E25 	Automatic calibration needed.	Call Service Centre for required Combustion Calibration. See also "Combustion calibration" on page 38.
SERVICE E26 	Gas valve remains closed.	Call Service Centre for required procedure.
SERVICE E29 	Flues system completely or partially closed.	Call Service Centre for checking cleanness of flues system, its capacity of aspiration/discharging and Gas inlet pressure.
SERVICE E31 	Communication error between Remote Control and boiler	User: Cut boiler power supply off for 30 seconds using the relevant external main switch, then restore it. If shut-down continues or occurs again, call the Assistance Service.
	▶ Remote Control not activated	Make sure that the Remote Control is active, namely that Remote Control (Summer) mode is selected, by using the button  of the Service Control Panel (see "Boiler and Remote Control activation" on page 57).
	▶ The data exchanged between boiler and Remote Control do not comply with the protocol provided for.	Problems on Remote Control electric line (it passes close to power supply cables or other electromagnetic field sources; faulty connection; cable longer than 50 metres).

Signal	Probable causes	Suggested solutions
RESET E35	Unexpected flame the control electronic has detected the flame on the burner when this one should be off	<p>Wait for the boiler automatic reset (5 minutes) or reset it manually by using the RESET button. If the lockout persists or reappears, call the Service Centre.</p> <p> Detect eventual malfunctioning of the gas valve (that does not stop fully the gas flow, so the burner remains ignited) or of the electronics, flame detection section (that detects the flame presence even if it's absent).</p>
SERVICE E38	<p>Failure to the outdoor temperature probe (optional).</p> <p>The outdoor temperature probe, that was recognized and working, now results faulty.</p>	<p>User: Call the Service Centre.</p> <p><i>The boiler now works either in heating and in hot water, like as the external boiler had never been installed, so the heating system temperature is set directly and not as a function of the outdoor temperature. The alarm is displayed to inform that the accessory is no more efficient (consider that, on a first analysis, the boiler seems to work perfectly). Important: if the boiler is turned off and then on again, it's possible** that the alarm is no more displayed, even though the problem persists.</i></p> <p>Check the cabling of the outdoor temperature probe.</p> <p>Replacement of the outdoor temperature probe.</p> <p><i>** The alarm shows again only if the resistance of the probe is out of tolerance or in short-circuit. On the contrary, if the probe or the relevant cabling is interrupted, when the electrical supply is restored the boiler will consider the external probe absent and, in Winter mode, it will work in normal mode (temperature shifting disabled).</i></p>
SERVICE E39	<p>Suspected freezing</p> <p>After a power failure, the boiler detected temperatures at the Heating and DHW probes equal to, or less than, 0°C when power was restored</p>	<p>The display shows the alarm code 39 while the boiler inhibits the ignition of the burner and activates the circulator, forcing water to circulate in the hydraulic circuits.</p> <p>If, during this time, the temperatures measured by the probes rise above +1°C, the alarm is reset and the boiler returns to the normal operation.</p> <p>Otherwise, the alarm will persist and you should suspect that water has frozen at one or more points of the hydraulic circuit of the boiler and/or system (with possible damage to the frozen parts). If the alarm persists, call a qualified technician.</p> <p> Find/replace the parts damaged by the freezing.</p>
RESET E43	<p>Return overheat. About 90°C felt by CH return probe.</p>	<p>User: Try only one boiler reset by using the RESET button.</p> <p>If the lockout persists or reappears, call the Service Centre for required procedure</p>

Signal	Probable causes	Suggested solutions
SERVICE E44 	Poor plant Circulation. Flow temperature increased too sharply.	Call Service Centre for required procedure.
SERVICE E45 	Return and flow probes inverted. Check CH probes (Flow and Return).	Call Service Centre for required procedure.
SERVICE E50 	Minimum Inlet voltage not correct (Min 195V).	Call Service Centre for checking inlet signal.
SERVICE E78 	Combustion check anomaly. Gas valve current out of range.	Call Service Centre for required procedure.
SERVICE E79 	Combustion check anomaly. Check Fan not finished.	Call Service Centre for required procedure.
SERVICE E88 	Combustion check anomaly. Modulator Gas valve current too high.	Call Service Centre for required procedure.
SERVICE E90 	Combustion check anomaly. Flame detection signal too high for 1 instant.	Call Service Centre for required procedure.
SERVICE E93 	Combustion check anomaly. Flame detection signal too high for more than 10 sec.	Call Service Centre for required procedure.
SERVICE E99 	PCB generic anomaly	Call Service Centre for required procedure.

Warnings for servicing



All servicing operations and gas conversions **MUST BE CARRIED OUT BY QUALIFIED TECHNICIANS**, in compliance with the norms and laws in force (see an indicative list on page 4). Moreover, **MAINTENANCE** operations must be carried out in compliance with the manufacturer prescriptions and with the laws and rules presently in force, for the parts not mentioned in this handbook; we advice to perform them at least once a year to maintain the boiler's performance.

A careful servicing is always a guarantee of safety and energy saving. Normally, it will be necessary to execute the following operations:

- ▶ Remove any possible oxidization from burners and electrodes;
- ▶ Remove the scale from the exchangers;
- ▶ Cleaning and checking the exchanger, the siphon and all the parts which are in touch with the condense;
- ▶ Check integrity and stability of the insulating coverings in the combustion chamber and proceed eventually to substitution;
- ▶ Check the boiler ignition, switching off and operation;
- ▶ Check the water and gas connections tightness;
- ▶ Check the gas consumption at the minimum and maximum output;
- ▶ Verify that safety devices are correctly working;
- ▶ Verify the correct functioning of control and adjusting devices;
- ▶ Verify periodically the absence of leaks of combustion products to the inner room, the correct functioning and the integrity of the flue outlet ducts and/or devices and of the relevant terminals and accessories;
- ▶ In case of works or servicing of the structures placed near the above mentioned ducts and /or devices and their accessories, switch off the boiler;
- ▶ Do not leave any inflammable tanks and/or substances in the installation room;
- ▶ If the boiler draws directly from the installation room (*type B appliance installed indoor*): Do not clean the room where boiler is installed, while it is working
- ▶ Clean casing with soapy water only. Do not clean casing, other painted or plastic surfaces with thinner.
- ▶ In any case of parts replacement, it is mandatory to use ITALTHERM original spare parts.

ITALTHERM declines any responsibility in case of non-original spare parts utilization.

ErP Data - EU 813/2013

Supplier name: Italtherm Contact details: Italtherm Srl – Via Salvo D'Acquisto, 10 – 29010 Pontenure (PC) – Italy		Model(s):		City Open 25 K	City Open 35 K
ErP Data - EU 813/2013		Symbol	Unit	Value	Value
Condensing boiler			Yes/No	YES	YES
Combination heater			Yes/No	YES	YES
B1 boiler			Yes/No	NO	NO
Cogeneration space heater:			Yes/No	NO	NO
Low-temperature (**) boiler			Yes/No	NO	NO
ErP space heating	Rated heat output	P_{rated}	kW	19	27
	Useful heat output at rated heat output and high-temperature regime (*)	P_4	kW	19.4	27.4
	Useful heat output at 30% at rated heat output and low-temperature regime (**)	P_1	kW	6.4	9.1
	Seasonal space heating energy efficiency (GCV)	η_s	%	91	91
	Useful efficiency at rated heat output and high-temperature regime (*) (GCV)	η_{14}	%	86.5	86.6
	Useful efficiency at 30% of rated heat output and low-temperature regime (**) (GCV)	η_1	%	95.8	96.1
ErP DHW	Declared load profile			XL	XXL
	Water heating energy efficiency (GCV)	η_{wh}	%	83	85
	Daily electricity consumption	Q_{elec}	kWh	0.161	0.160
	Daily fuel consumption	Q_{fuel}	kWh	23.5	28.4
Auxiliary electricity consumption	At full load	e_{lmax}	kW	0.027	0.035
	At part load	e_{lmin}	kW	0.012	0.012
	In standby mode	P_{sb}	kW	0.005	0.005
Other items	Standby heat loss	P_{sby}	kW	0.053	0.075
	Ignition burner power consumption	P_{ign}	kW	0.000	0.000
	Sound power level, indoors	L_{WA}	dB	54	55
	Emissions of nitrogen oxides	NO_x	mg/kWh	32.0	40

(*) High-temperature regime means: 60 °C return temperature at heater inlet and 80 °C feed temperature at heater outlet.
(**) Low temperature means: for condensing boilers 30 °C, for low-temperature boilers 37 °C and for other heaters 50 °C return temperature (at heater inlet).
GCV = Gross Calorific Value (=Hs)

Product fiche - EU 811/2013

Supplier name: Italtherm Contact details: Italtherm Srl – Via Salvo D'Acquisto, 10 – 29010 Pontenure (PC) – Italy		Model(s):		City Open 25 K	City Open 35 K
Product fiche - EU 811/2013		Symbol	Unit	Value	Value
Declared load profile DHW				XL	XXL
Seasonal energy efficiency for space heating				A	A
Energy efficiency for water heating				A	B
Rated heat output		P_{rated}	kW	19	27
Annual energy consumption		Q_{HE}	GJ	34	49
Annual electricity consumption		AEC	kWh	35	35
Annual fuel consumption		AFC	GJ	18	22
Seasonal space heating energy efficiency (GCV)		η_s	%	91	91
Water heating energy efficiency (GCV)		η_{wh}	%	83	85
Sound power level, indoors		L_{WA}	dB	54	55

GCV = Gross Calorific Value (=Hs)

Technical data

- Q_{nw}** Maximum heat input in DHW mode, determined by the burner model and the advanced settings
Q_n Maximum heat input in heating mode, **at factory settings** (see also "Power adjustment tables" on page 37)
Q_a Heat input, at the arithmetic average of the maximum and minimum thermal capacity
Q_r Minimum heat input (both in heating and DHW modes)
 * system return / flow water temperature
NCV Net Calorific Value (=Hi)

Remark: data have been measured with horizontal coaxial flue, length = 1 m

TECHNICAL DATA	U.M.	City Open 25 K			City Open 35 K		
		G20	G31	G230 ¹	G20	G31	G230 ¹

CE certification		0476 CS 1134			0476 CS 1134		
Class		II ₂ HM3P (II ₂ H3P) ²			II ₂ HM3P (II ₂ H3P) ²		
Type		B23 - B23P - B53 - B53P - C13 - C33 - C43 - C53 - C63 (C13-C33-C53-C83) - C83 - C93					
Working temperature range (min÷max)	°C	0 ÷ +60			0 ÷ +60		

(1) = allowed in Italy only (2) = outside Italy

Max heat input Q _{nw}	kW	25.0	25.0	25.0	33.2	33.2	33.2
Max heat input Q _n	kW	20.0	20.0	20.0	28.0	28.0	28.0
Min heat input Q _r	kW	2.5	2.5	2.5	3.5	3.5	3.5
Max heat output 60°/80°C *	kW	19.4	19.4	19.4	27.4	27.4	27.4
Min heat output 60°/80°C *	kW	2.4	2.4	2.4	3.3	3.3	3.3
Max heat output 30°/50°C *	kW	21.0	21.0	21.0	29.5	29.5	29.5
Min heat output 30°/50°C *	kW	2.7	2.7	2.7	3.7	3.7	3.7
NO _x Class		6	6	6	6	6	6
CO at 0% O ₂ at Q _{nw}	ppm	230.1	217.0	281.7	169.0	205.5	263.1
CO at 0% O ₂ at Q _n	ppm	157.8	157.2	177.0	135.2	206.8	276.3
CO ₂ at Q _{nw}	%	9.00	10.04	10.30	9.00	10.20	10.40
CO ₂ at Q _n	%	8.90	10.02	10.10	9.00	10.40	10.50
Condense quantity at Q _n (30°/50°C *)	l/h	2.1	2.1	2.1	2.5	2.5	2.5
Condense quantity at Q _r (30°/50°C *)	l/h	0.3	0.3	0.3	0.4	0.4	0.4
Condense acidity	pH	2.8	2.8	2.8	2.8	2.8	2.8
Flue temperature, Max.	°C	61.5 60/80° Q _r	61.5 60/80° Q _r	61.5 60/80° Q _r	64.0 60/80° Q _n	64.0 60/80° Q _n	64.0 60/80° Q _n
Flue temperature, Min.	°C	41.0 30/50° Q _r	41.0 30/50° Q _r	41.0 30/50° Q _r	38.0 30/50° Q _r	38.0 30/50° Q _r	38.0 30/50° Q _r
Flue mass flow rate at Q _{nw} (60/80°C *)	kg/h	41.11	41.86	44.33	54.60	54.41	58.35
Flue mass flow rate at Q _n (60/80°C *)	kg/h	33.24	33.55	36.11	46.05	45.05	48.77
Flue mass flow rate at Q _r (60/80°C *)	kg/h	3.94	4.22	4.60	5.76	5.63	6.62

EFFICIENCY

Efficiency η _{100%} Q _n /Q _a (NCV) at 60°/80°C *	%	96.1			96.2		
Efficiency at Q _n (NCV) at 30°/50°C *	%	105.1			106.4		
Efficiency at η _{30%} Q _n /Q _a (NCV) at 30°/50°C *	%	106.4			106.7		

HEATING

Temperature selection range (min÷max) Main heating circuit, normal range / low temp. range	°C	35÷80 / 20÷45					
Temperature selection range (min÷max) Secondary heating circuit	°C	20÷80					
Characteristics of the heating system water (or filling liquid) (* = if aluminium parts are present along the system)	°f pH	5 ÷ 15 °f pH 7.5 ÷ 9.5 (7.5 ÷ 8.5 *)					

(follows)

TECHNICAL DATA (cont'd)	Gas type	U.M.	City Open 25 K			City Open 35 K		
			G20	G31	G230 ¹	G20	G31	G230 ¹
Expansion vessel		l	10			10		
Expansion vessel pre-loading pressure		bar	1			1		
Loss of water pressure switch off / on pressure		bar	0.5 / 1.2 (±0.2)			0.5 / 1.2 (±0.2)		
			<i>To allow the correct system filling, the pressure of the domestic water should be higher than the ON value of the pressure switch.</i>					
Max working pressure		bar	3			3		
Max system temperature		°C	90			90		
Anti-freezing boiler's function temperature on / off		°C	5 / 30			5 / 30		
Anti-freezing electric heaters temperature on / off		°C	5 / 16			5 / 16		
HOT WATER								
Flow rate at 25°C temp. rise		l/min	14.8			18.7		
Flow rate at 30°C temp. rise		l/min	12.0			16.0		
Min water flow <i>(for the DHW function activation)</i>		l/min	2.8			2.8		
Min supply pressure <i>(for the DHW function activation)</i>		bar	0.2			0.2		
Max supply pressure		bar	6			6		
Temperature selection range (min÷max)		°C	30÷55			30÷55		
Flue temperature, average (DHW, ΔT 25°C)		°C	54			56		
Flue temperature, average (DHW, ΔT 30°C)		°C	57			59		
ELECTRICAL DATA								
Voltage / frequency (nominal voltage)		V / Hz	220÷240 / 50 (230V)			220÷240 / 50 (230V)		
Power consumption (electric heaters OFF)		W	73			86		
Power consumption of electric heaters		W	38			38		
Level of protection			IP X5D			IP X5D		
DIMENSIONS								
Width - Height - Depth		mm	<i>see "Dimensions and connections" on page 12</i>					
Weight: net / gross		kg	28.4 / 30.8			34.2 / 36.6		
CONNECTIONS								
Hydraulic and gas connections			<i>see "Dimensions and connections" on page 12</i>					
Flue: types, lengths and diameters			<i>see "Flue systems" on page 21</i>					
Delta P outlet/inlet (fan head loss)		Pa	10 ÷ 145			20 ÷ 160		
GAS SUPPLY PRESSURE								
Nominal pressure		mbar	20	37	20	20	37	20
Inlet pressure (min÷max)		mbar	17 ÷ 25	35 ÷ 40	17 ÷ 25	17 ÷ 25	35 ÷ 40	17 ÷ 25
GAS CONSUMPTION								
at Q _{nw}		m ³ /h	2.64		2.05	3.51		2.72
		kg/h		1.94			2.57	
at Q _n		m ³ /h	2.11		1.64	2.96		2.30
		kg/h		1.55			2.17	
at Q _r		m ³ /h	0.26		0.21	0.37		0.29
		kg/h		0.19			0.27	

Boiler internal components

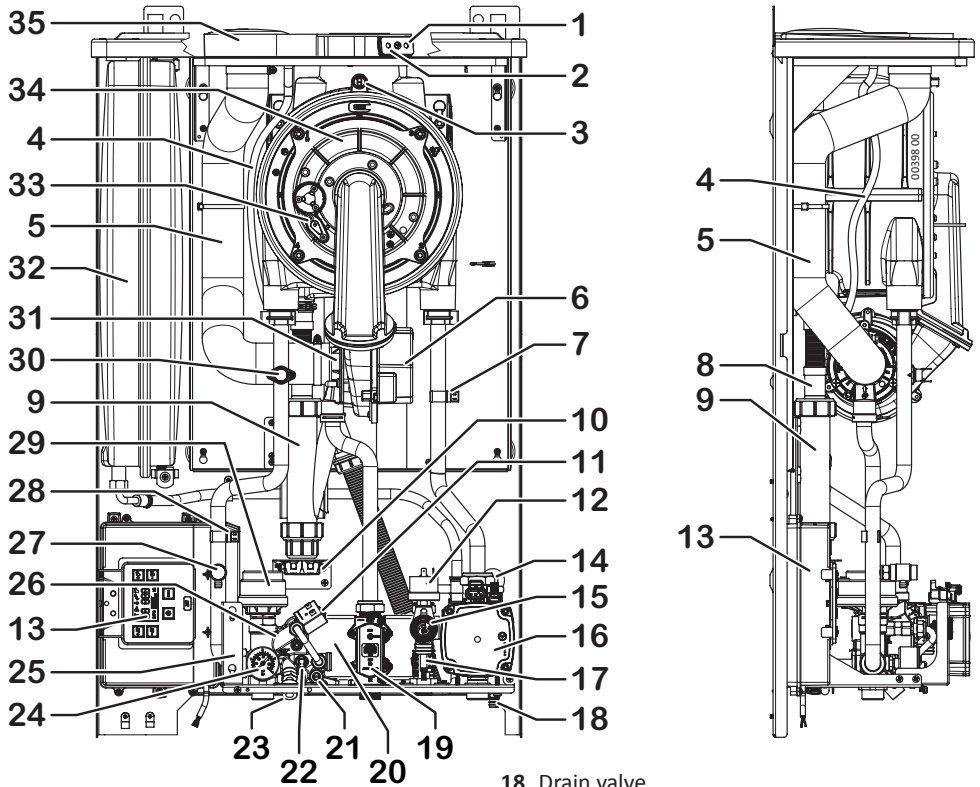

- | | |
|--|---|
| 1 Plug for Combustion analysis (air intake) | 18 Drain valve |
| 2 Plug for Combustion analysis (flue) | 19 Gas valve |
| 3 Flue overheat fuse | 20 DHW exchanger |
| 4 Water drain pipe from air intake flange | 21 DHW flow regulator |
| 5 Air intake hose | 22 DHW temperature sensor |
| 6 Fan | 23 Filling valve, manual |
| 7 Temperature Sensor on system return | 24 System pressure gauge |
| 8 Condense drain pipe from combustion assembly | 25 Service support for electric box |
| 9 Siphon for condense outlet | 26 By-pass (in-built in the 3-way valve hydraulic assembly) |
| 10 Electric heaters (5x) <i>(dettaglio di 2 parti su 3 in caldaia, più 2 "volanti" per i raccordi)</i> | 27 Manual Venting Device (Combustion assembly) |
| 11 System filling electrovalve | 28 Temperature Sensor, system flow |
| 12 System pressure switch | 29 Motorized 3-way valve |
| 13 Electric box with service control panel | 30 Safety thermostat on system flow |
| 14 Automatic Venting Device (heating circuit, incorporated in the pump) | 31 Air/Gas Mixing device |
| 15 Safety valve 3 bar | 32 Expansion Vessel |
| 16 Pump | 33 Flame ignition/detection electrode |
| 17 Priority flow switch (with filter) | 34 Combustion assembly (burner+primary exchanger) |
| | 35 Flue connection flange |

Electrical diagram

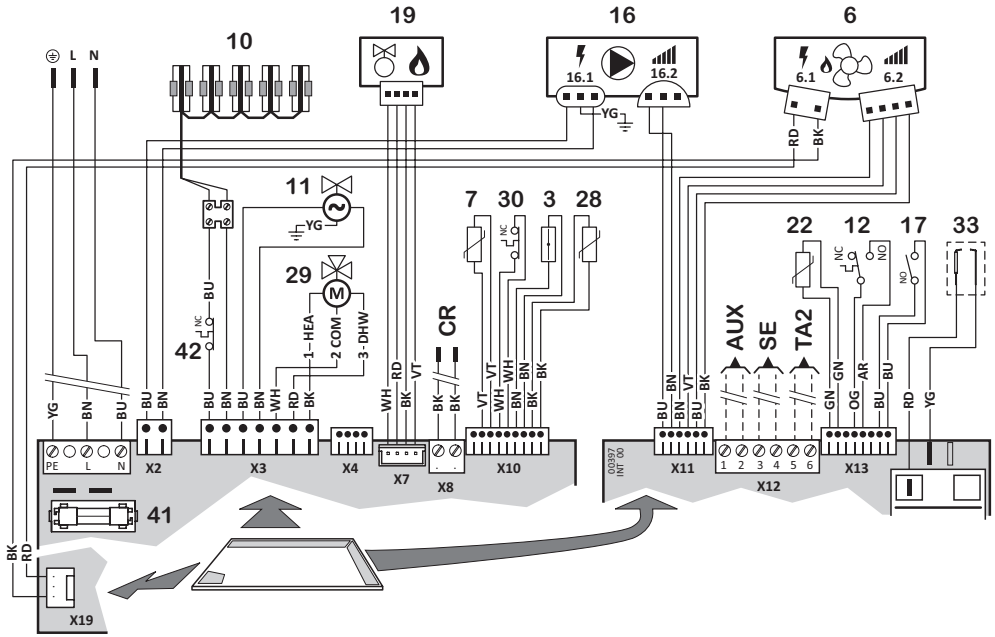

- 3 Flue overhear fuse
- 6.1 Fan - supply
- 6.2 Fan - speed control
- 7 Temperature Sensor on system return
- 10 Electric heaters
- 11 System filling electrovalve
- 12 System pressure switch (*)
- 16.1 Pump - supply
- 16.2 Pump - modulation control
- 17 Priority flow switch (with filter) (*)
- 19 Gas valve
- 22 DHW temperature sensor
- 28 Temperature Sensor, system flow
- 29 Motorized 3-way valve
- 30 Safety thermostat on system flow (*)
- 33 Flame ignition/detection electrode
- 41 Fuse F2A (2A fast)
- 42 Electric heaters' thermostat
- CR Remote control** (original only)

(*) the contacts of these components are shown in "normal" conditions (i.e. temperature below threshold, cold system, no system pressure, no flow)

Optional external devices:

- SE** To optional outdoor temperature sensor
- TA2** To optional room thermostat for zones with different temperature range
- AUX** Input for optional device, configurable with Parameter 46 (see page 35).

Abbreviations: COM Common ● NC Normally closed (contact) ● NO Normally open (contact)
 ● HEA Heating (diverting command) ● DHW Hot water (diverting command)

Colours: BK Black ● BN Brown ● BU Blue
 ● GN Green ● RD Red ● OG Orange ● VT Violet
 ● WH White ● YE Yellow ● YG Yellow-Green

Hydraulic diagram

(i) This diagram is for information only. To make boiler hydraulic connection either see "Dimensions and connections" on page 12 and eventually "Positioning and fastening" on page 15.

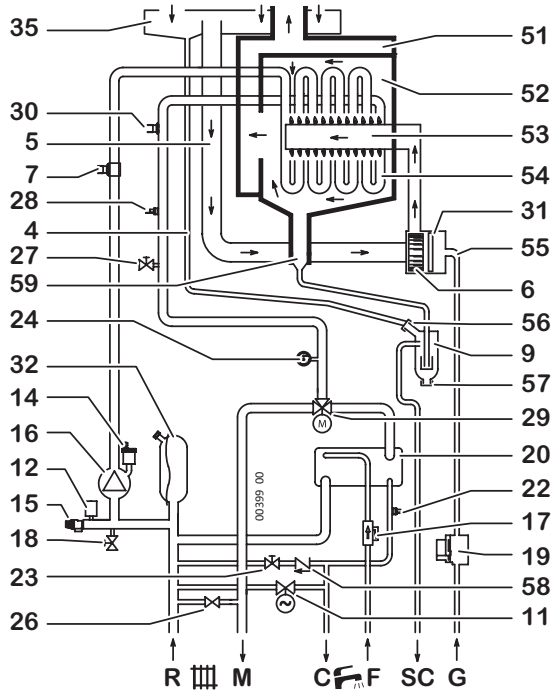

- | | | | |
|----|--|----|---|
| 4 | Water drain pipe from air intake flange | 29 | Motorized 3-way valve |
| 5 | Air intake hose | 30 | Safety thermostat on system flow |
| 6 | Fan | 31 | Air/Gas Mixing device |
| 7 | Temperature Sensor on system return | 32 | Expansion Vessel |
| 9 | Siphon for condense outlet | 35 | Flue connection flange |
| 11 | System filling electrovalve | 51 | Flue hood |
| 12 | System pressure switch | 52 | Combustion chamber |
| 14 | Automatic Venting Device (heating circuit, incorporated in the pump) | 53 | Burner |
| 15 | Safety valve 3 bar | 54 | Primary exchanger |
| 16 | Pump | 55 | Gas pipe |
| 17 | Priority flow switch (with filter) | 56 | Inlet of water from air intake in the condense siphon |
| 18 | Drain valve | 57 | Tap for condense siphon cleaning |
| 19 | Gas valve | 58 | Check valve |
| 20 | DHW exchanger | 59 | Condense drain in combustion assembly |
| 22 | DHW temperature sensor | | |
| 23 | Filling valve, manual | R | Heating return |
| 24 | System pressure gauge | M | Heating flow |
| 26 | By-pass (in-built in the 3-way valve hydraulic assembly) | C | Hot water outlet |
| 27 | Manual Venting Device (Combustion assembly) | F | Cold water inlet |
| 28 | Temperature Sensor, system flow | SC | Condense drain |
| | | G | Gas inlet |



Outdoor Sensor Kit

Installation and setting

The Outdoor Sensor manages automatically the CH flow temperature** as a function of the outdoor temperature, thus avoiding the user to adjust it manually. This function is also named "shifting temperature".

** that's the temperature of the heating elements. Don't mistake it with the room temperature (managed by the Remote Control as well) that doesn't depend on the first one.

Installation must be carried out by a qualified technician following the instructions supplied with the kit. The External Probe must be connected to the suitable terminals, not polarised, of the boiler management board. Refer to "Electrical diagram" on page 53.

After installing the external Probe, to adjust the heating, refer to the Remote Control instruction booklet, in particular to the parts that describe the External Probe and the graph containing the range of available OTC curves:

In practice, as you can see in the above mentioned graph, the "climatic curve", or "OTC curve" is the delivery temperature trend depending on the external temperature measured by the probe. It **must be chosen according to the estimated quality of the property thermal insulation**. In case of **high heat loss** and therefore **less efficient insulation**, chose a **curve represented by a high value**. and vice versa.

 Given the great variety of property types, it is not possible to give precise indications on the climatic curve to chose. **A correct adjustment will have to be evaluated case by case and will result in best comfort in all weather conditions** which require heating, i.e. a quick achievement of ambient temperature at cold climate conditions and absence of overheating at mild climate.

The Service Control Panel



ALL the operations on the Service Control Panel are RESERVED to authorised Technical Personnel.

The boiler electronic control is equipped with a Service Control Panel, namely with manual basic controls that allow accessing functions reserved to the Technician. Moreover, in case of failure of the Remote Control, it allows to operate the boiler temporarily, with basic functions only, while the original spare Remote Control is being acquired.

To access it, it is necessary to remove the boiler insulating covering (see "Access to the inside of the boiler" on page 29).



WARNING - Risk of electrocution!

Since the Service Control Panel is used with the boiler without insulating cover and electrically powered (namely under conditions that do NOT validate the declared IP electrical protection), **it is FORBIDDEN for ANYONE, EVEN for technical personnel, to use it under wet conditions or when there is the risk of humidity.**

In any case, even under optimal conditions, **avoid contact with all the internal components** except only for the Service Control Panel.



Stand-by / Functioning mode

Every time it is pressed, the boiler cyclically switches from the **OFF** mode to “**Summer – Remote Control**” and “**Winter**” operating modes. The current mode is indicated on the display by the wording **OFF** (boiler in stand-by) or by the presence of symbol but not of symbol (Summer – Remote Control mode, i.e. boiler standard operating mode) or by the simultaneous presence of symbols and (Winter mode).

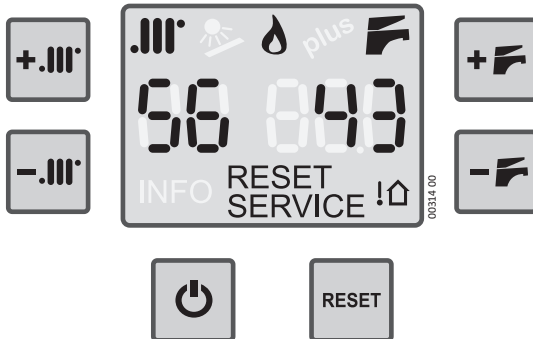

** CH setting

To set the CH system temperature. If the Outdoor Sensor Kit was installed, see also “Outdoor Sensor Kit” on page 55.

** DHW setting

To set the DHW temperature.

RESET ** Press to reset the boiler in case of breakdown.

See further details in “Alarms - boiler block” on page 41.

Display - symbols enabled in this model and their description

** CH – winter mode indication

If flashing, it means that the boiler is functioning in CH mode. See also the remark in the description of symbol .



Burner ON

It indicates the presence of the flame in the burner.



** DHW mode indication

If flashing, it means that the boiler is functioning to produce hot water.

If both and symbols flash at the same time, a Technician-reserved function has been activated. In this case, turn immediately the boiler off - and then turn it on again - by means of the button .



Two digit display under the symbol

Normally, it displays the **CH flow** temperature, i.e the temperature of the liquid on boiler's outlet that is sent to the CH system.



During the CH temperature setting (by pressing the buttons and) , it shows the **temperature value changing**; in case of **alarm it displays "E"**; during the **setting (reserved to the Technician)** it displays the chosen **parameter ID number** (see “PCB parameters settings (technician menu)” on page 32).



Three digit display under the symbol

Normally, it displays the temperature of the hot water on boiler's outlet. When the boiler is in manual stand-by mode, it displays .



During the DHW temperature** setting (by pressing the buttons  and ), it shows the **temperature value changing**; in case of **alarm** it displays the **ID number** of the alarm (see "Alarms - boiler block" on page 41); during the **setting (reserved to the Technician)** it displays the **value** of the chosen **parameter**.

RESET



It appears when the boiler is locked or anyway is present an error that the user could manage. See "Alarms - boiler block" on page 41 to identify the problem and the relevant actions to be carried out.

SERVICE





It appears when the boiler has detected an error (mainly a fault) that has to be managed by the Technician. The User can anyway see "Alarms - boiler block" on page 41 to get information about and the eventual actions to be carried out.





It informs that the outdoor probe (accessories) is installed.

*Note: In this case the CH system temperature is automatically set and so **the use of buttons  and  is different from the standard way: for deeper details rely on kit instruction and see "Outdoor Sensor Kit" on page 55.*

Boiler and Remote Control activation









- ▶ After performing the complete installation correctly, power the boiler.
 - the Remote Control should be functioning and in the conditions described in the relevant instruction booklet (paragraph "INTERFACE"). Otherwise, proceed as follows.
- ▶ Access the Service Control Panel and press the button . Every time it is pressed, the boiler cyclically switches to the following modes:
 - **(Manual) MODE **, that is to say boiler in **manual stand-by**. Operating conditions are the same as those of the OFF status controlled by the Remote Control (in particular, the anti-freeze functions, see "OFF mode with anti-frost & anti-locking function" on page 10), but the Remote Control is disabled.
 - **Remote Control MODE** or **Summer (manual) MODE **: Remote Control enabled and boiler ready for operation. The Remote Control is in the conditions described in the relevant instruction booklet (paragraph "INTERFACE") and it interacts with the boiler functions;
 - **in this case, the activation is complete.** If there are no other technical operations to be performed on the Service Control Panel, do not press again the button , close the boiler and from now on use the Remote Control;
 - otherwise, there may be a malfunction of the connection between Remote Control and Boiler, of the Remote Control itself or of the boiler management board. In this mode, the boiler is in Summer (manual) mode and, except in case of management board faults, it can be used **temporarily** only to fulfil the needs for the domestic hot water. The relevant temperature can be set through the Service Control Panel itself, as described in "Temperature adjustment (manual working modes)" on page 58.
 - Should it be necessary to activate also the heating (**temporarily** without the Remote Control) switch the boiler to **Winter (manual) MODE**, see the next point.

- **Winter (manual) MODE**  + . This mode is required for:
 - technical operations requiring forced ignition of the burner.
 - moreover, this mode can be used **temporarily** in case of Remote Control malfunction during the winter period, to fulfil the needs for domestic hot water and heating. Please, consider that heating will be activated only upon the closure of a voltage-free contact (of an ambient thermostat or of a timed thermostat) connected to **CR** terminals that are normally intended for the Remote Control - see "Electrical diagram" on page 53. Domestic hot water and heating temperatures can be set through the Service Control Panel itself, as described in "Temperature adjustment (manual working modes)" on page 58.

Temperature adjustment (manual working modes)

Note: if a Low Temperature Kit or an Outdoor Probe Kit are installed, refer to the relevant documentation for what concerns the heating system temperature adjustment.

Note: don't mistake the heating system temperature  here described, with the room temperature set on the Remote Control or on an eventual Room Thermostat provisionally installed.

- ▶ **Heating system adjustment:** by using the buttons  and , the setting of the heating system temperature is made (the value, during the adjustment, is shown on the display under the symbol ). Generally, in the deep cold season and/or with poor building thermal insulation (or if you notice that the burner stays on for a long time, but the room temperature rises too slowly) prefer higher settings. On the contrary, if you notice that the room temperature exceeds too much, for thermal inertia, the value set on the room temperature, it's appropriate to decrease the system temperature. **When the optional Outdoor Temperature Probe Kit is installed, the system temperature is automatically managed and the use of the buttons  and  is different: for details, see also "Outdoor Sensor Kit" on page 55.**
- ▶ **Domestic hot water adjustment:** the buttons  and  set the temperature of the hot water produced by the boiler (the value, during the adjustment, is shown on the display under the symbol ). On this type of boiler, we suggest to set it in such a way to have a comfortable hot water temperature by drawing only hot water or eventually by mixing it with a little cold water. Avoid maximum values if not strictly needed, that will force to mix the hot water with bigger quantities of cold water. Consider that, because of the dispersions along the pipings, a certain time is needed to have a stable water temperature on the cock outlet, therefore the best temperature evaluation is achieved during a bath or a shower.



WARNING - Always close and fasten the boiler insulating covering! Risk of electrocution and damage!

Never allow the User to access the Service Control Panel since it is close to live parts. Otherwise, the Manufacturing company will decline any liability for damage to persons, animals or property. The boiler is designed to be installed outdoor, in a partially protected place, and even indirect exposure of internal components to atmospheric agents (humidity, mist etc.) can extend the risk of electrocution to all the surfaces of the appliance and cause damage to the boiler or faults.

The IP electrical protection degree of the appliance is obtained only if the insulating covering, complete with lower and upper covers, is correctly installed and fastened.

