

TPA005D14 Class-D Stereo Audio Power Amplifier Evaluation Module

User's Guide

IMPORTANT NOTICE

Texas Instruments and its subsidiaries (TI) reserve the right to make changes to their products or to discontinue any product or service without notice, and advise customers to obtain the latest version of relevant information to verify, before placing orders, that information being relied on is current and complete. All products are sold subject to the terms and conditions of sale supplied at the time of order acknowledgement, including those pertaining to warranty, patent infringement, and limitation of liability.

TI warrants performance of its semiconductor products to the specifications applicable at the time of sale in accordance with TI's standard warranty. Testing and other quality control techniques are utilized to the extent TI deems necessary to support this warranty. Specific testing of all parameters of each device is not necessarily performed, except those mandated by government requirements.

CERTAIN APPLICATIONS USING SEMICONDUCTOR PRODUCTS MAY INVOLVE POTENTIAL RISKS OF DEATH, PERSONAL INJURY, OR SEVERE PROPERTY OR ENVIRONMENTAL DAMAGE ("CRITICAL APPLICATIONS"). TI SEMICONDUCTOR PRODUCTS ARE NOT DESIGNED, AUTHORIZED, OR WARRANTED TO BE SUITABLE FOR USE IN LIFE-SUPPORT DEVICES OR SYSTEMS OR OTHER CRITICAL APPLICATIONS. INCLUSION OF TI PRODUCTS IN SUCH APPLICATIONS IS UNDERSTOOD TO BE FULLY AT THE CUSTOMER'S RISK.

In order to minimize risks associated with the customer's applications, adequate design and operating safeguards must be provided by the customer to minimize inherent or procedural hazards.

TI assumes no liability for applications assistance or customer product design. TI does not warrant or represent that any license, either express or implied, is granted under any patent right, copyright, mask work right, or other intellectual property right of TI covering or relating to any combination, machine, or process in which such semiconductor products or services might be or are used. TI's publication of information regarding any third party's products or services does not constitute TI's approval, warranty or endorsement thereof.

Preface

Related Documentation From Texas Instruments

- ***TI Plug-N-Play Audio Amplifier Evaluation Platform*** (TI Literature Number SLOU011) provides detailed information on the evaluation platform and its use with TI audio evaluation modules.
- ***TPA005D14 CLASS-D STEREO AUDIO POWER AMPLIFIER*** (TI Literature Number SLOS240) This is the data sheet for the TPA005D14 audio amplifier integrated circuit.
- ***Design Considerations for Class-D Audio Power Amplifiers*** (TI Literature Number SLOA031) This application report provides detailed information on designing audio power amplifier systems using TI class-D amplifier ICs.
- ***Reducing and Eliminating the Class-D Output Filter*** (TI Literature Number SLOA023) This application report covers output filter theory and design for class-D audio power amplifiers.

FCC Warning

This equipment is intended for use in a laboratory test environment only. It generates, uses, and can radiate radio frequency energy and has not been tested for compliance with the limits of computing devices pursuant to subpart J of part 15 of FCC rules, which are designed to provide reasonable protection against radio frequency interference. Operation of this equipment in other environments may cause interference with radio communications, in which case the user at his own expense will be required to take whatever measures may be required to correct this interference.

Trademarks

TI is a trademark of Texas Instruments Incorporated.
PowerPAD is a trademark of Texas Instruments Incorporated.



Contents

1	Introduction	1-1
1.1	Feature Highlights	1-2
1.2	Description	1-3
1.3	TPA005D14 Class-D EVM Specifications	1-4
2	Quick Start	2-1
2.1	Precautions	2-2
2.2	Quick Start List for Platform	2-3
2.3	Quick Start List for Stand-Alone	2-4
3	Details	3-1
3.1	Precautions	3-2
3.2	The TPA005D14 Class-D Audio Power Amplifier Evaluation Module	3-3
3.2.1	TPA005D14 Class-D Stereo Audio Amplifier IC	3-5
3.2.2	Overview of Class-D Audio Amplifiers	3-6
3.2.3	Bridge-Tied Load (BTL) Operation	3-7
3.2.4	Class-D Differential and Headphone Single-Ended Inputs	3-8
3.2.5	Control and Indicator Circuits	3-8
3.2.6	TPA005D14 Class-D EVM Test Points	3-9
3.3	Class-D Amplifier Design Considerations	3-10
3.4	Using The TPA005D14 Class-D EVM With the Plug-N-Play Platform	3-11
3.4.1	Installing and Removing EVM Boards	3-11
3.4.2	Module Switches	3-12
3.4.3	Signal Routing	3-13
3.4.4	Shutdown	3-14
3.4.5	Power Requirements	3-16
3.4.6	Inputs and Outputs	3-17
3.5	Using The TPA005D14 Class-D EVM Stand-Alone	3-18
3.5.1	Power Connections	3-18
3.5.2	Input Connections	3-19
3.5.3	Output Connections	3-19
3.5.4	Controls and Indicators	3-19
3.6	TPA005D14 Class-D EVM Performance Characteristics	3-20
3.7	TPA005D14 Class-D EVM Interconnects	3-27
3.8	TPA005D14 Class-D EVM Bill of Materials	3-28
3.9	TPA005D14 Class-D EVM Schematic	3-29
3.10	TPA005D14 Class-D EVM PCB Layers	3-30

Figures

1-1	The TI TPA005D14 Class-D Stereo Audio Power Amplifier EVM — Top View	1-3
1-2	The TI TPA005D14 Class-D Stereo Audio Power Amplifier EVM — Bottom View	1-3
2-1	Quick Start Platform Map	2-2
3-1	The TI Plug-N-Play Audio Amplifier Evaluation Platform	3-2
3-2	The TI TPA005D14 Class-D Stereo Audio Power Amplifier EVM — Top View	3-4
3-3	The TI TPA005D14 Class-D Stereo Audio Power Amplifier EVM — Bottom View	3-4
3-4	TPA005D14 Class-D EVM Schematic Diagram	3-5
3-5	Class-D Functional Diagram	3-6
3-6	Class-D Input and Output Waveforms	3-7
3-7	Platform Signal Routing and Outputs	3-13
3-8	Mute/Mode and Polarity Control	3-14
3-9	Typical Headphone Plug	3-17
3-10	TPA005D14 Class-D EVM Stand-Alone Connections for Stereo BTL Output	3-18
3-11	Class-D Amplifier Frequency Response at 4 Ω	3-20
3-12	Class-D Amplifier Distortion versus Output Power at 4 Ω	3-21
3-13	Class-D Amplifier Distortion versus Output Power at 8 Ω	3-21
3-14	Class-D Amplifier Distortion versus Frequency at 1 W Into 4 Ω	3-22
3-15	Class-D Amplifier Distortion versus Frequency at 1 W Into 8 Ω	3-22
3-16	Class-D Amplifier Crosstalk versus Frequency at 2 W Into 4 Ω	3-23
3-17	Class-D Amplifier Crosstalk versus Frequency at 2 W Into 8 Ω	3-23
3-18	Class AB Headphone Amplifier Frequency Response.	3-24
3-19	Class AB Headphone Amplifier Distortion versus Output Power.	3-25
3-20	Class AB Headphone Amplifier Distortion versus Frequency.	3-25
3-21	Class AB Headphone Amplifier Crosstalk versus Frequency	3-26
3-22	TPA005D14 Class-D EVM Schematic Diagram	3-29
3-23	TPA005D14 Class-D EVM Top Assembly.	3-30
3-24	TPA005D14 Class-D EVM Bottom Assembly	3-30
3-25	TPA005D14 Class-D EVM Top Layer	3-31
3-26	TPA005D14 Class-D EVM Second Layer.	3-31
3-27	TPA005D14 Class-D EVM Third Layer.	3-32
3-28	TPA005D14 Class-D EVM Bottom Layer.	3-32

Tables

2-1	Typical TI Plug-N-Play Platform Jumper and Switch Settings for the TPA005D14 Class-D EVM	2-1
2-2	Platform Jumper and Switch Settings for the TPA005D14	2-3
3-1	TPA005D14 Class-D EVM Fault Indicator Table	3-8
3-2	TPA005D14 Class-D EVM Test Points	3-9
3-3	Platform Jumper and Switch Settings for the TPA005D14 EVM Power Inputs	3-16
3-4	TPA005D14 Class-D EVM/Plug-N-Play Platform Interconnects	3-27
3-5	TPA005D14 Class-D EVM Bill of Materials	3-28

Introduction

This chapter provides an overview of the Texas Instruments (TI™) TPA005D14 class-D stereo audio power amplifier evaluation module (SLOP204). It includes a list of EVM features, a brief description of the module illustrated with a pictorial diagram, and a list of EVM specifications.

Topic	Page
1.1 Feature Highlights	1-2
1.2 Description	1-3
1.3 TPA005D14 Class-D EVM Specifications	1-4

1.1 Feature Highlights

The TI TPA005D14 class-D stereo audio power amplifier evaluation module and the TI plug-n-play audio amplifier evaluation platform include the following features:

- TPA005D14 Class-D Stereo Audio Power Amplifier Evaluation Module
 - Internal depop circuitry to significantly reduce turn-on transients in outputs
 - Dual channel, bridge-tied load (BTL) only operation
 - 5 V operation
 - 2 W BTL output into 4 Ω at 5 V
 - Low current consumption in shutdown/mute mode (50 μ A/2.5 mA)
 - Internal gain set to 20 dB
 - IC shutdown, mute, and mode control inputs — TTL logic level
 - High efficiency
 - Class-AB stereo headphone driver — capable of 50 mW into 32 Ω
 - CE tested and approved

- Quick and Easy Configuration With the TI Plug-N-Play Audio Amplifier Evaluation Platform
 - Evaluation module is designed to simply plug into the platform, automatically making all signal, control, and power connections
 - Platform provides flexible power options
 - Jumpers on the platform select power and module control options
 - Switches on the platform route signals
 - Platform provides quick and easy audio input and output connections

- Platform Power Options
 - External 5-V – 15-V V_{CC} supply inputs
 - External regulated V_{DD} supply input
 - Socket for onboard 5 V/3.3 V V_{DD} voltage regulator EVM
 - Onboard overvoltage and reverse polarity power protection

- Platform Audio Input and Output Connections
 - Left and right RCA phono jack inputs
 - Miniature stereo phone jack input
 - Left and right RCA phono jack outputs
 - Left and right compression speaker terminal outputs
 - Miniature stereo headphone jack output

1.2 Description

The TPA005D14 class-D stereo audio power amplifier evaluation module is a complete, 2-Watt per channel stereo audio power amplifier. It consists of the TI TPA005D14 class-D stereo audio power amplifier IC along with a small number of other parts mounted on a circuit board that measures approximately 2 ¼ inches by 2 ¼ inches (Figure 1–1 and 1–2).

Figure 1–1. The TI TPA005D14 Class-D Stereo Audio Power Amplifier EVM — Top View

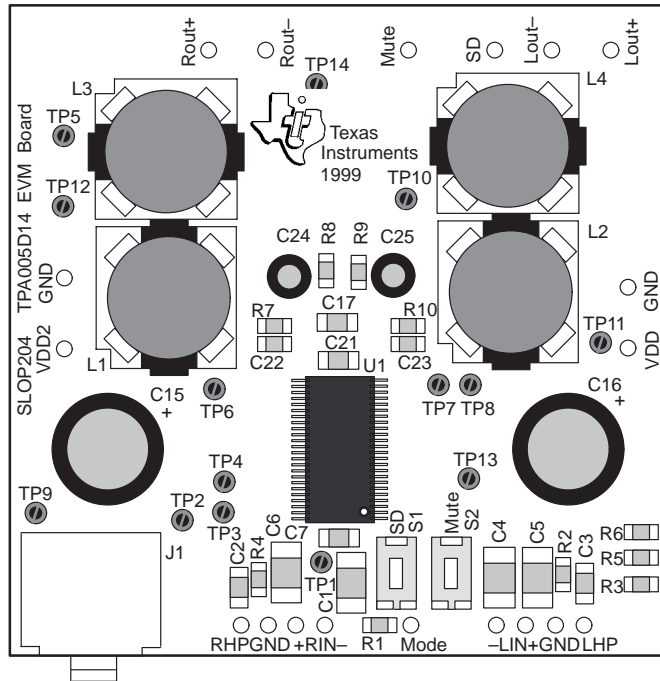
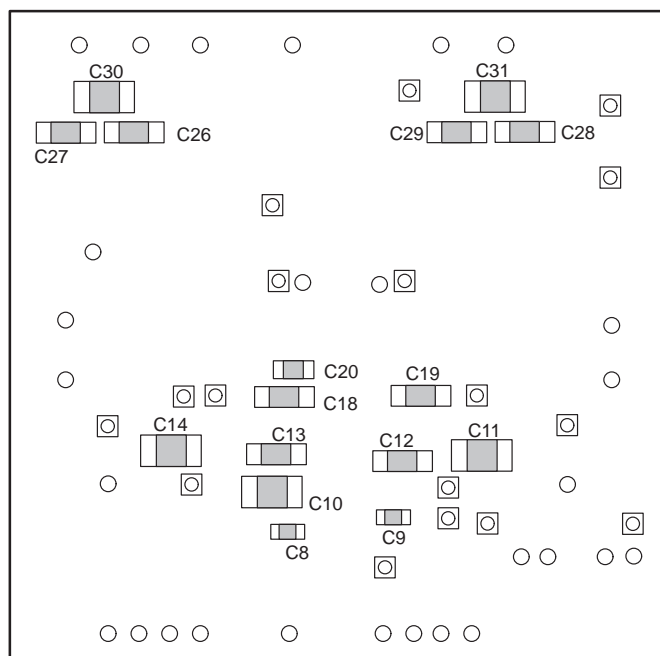

Figure 1–2. The TI TPA005D14 Class-D Stereo Audio Power Amplifier EVM — Bottom View



Single in-line header pins extend from the underside of the module circuit board to allow the EVM to either be plugged into the TI plug-n-play audio amplifier evaluation platform, or to be wired directly into existing circuits and equipment when used stand-alone.

The platform has room for a single TPA005D14 class-D evaluation module and is a convenient vehicle for demonstrating TI's audio power amplifier and related evaluation modules. The EVM simply plugs into the platform, which automatically provides power to the modules, interconnects them correctly, and connects them to a versatile array of standard audio input and output jacks and connectors. Easy-to-use configuration controls allow the platform and EVMs to quickly model many possible end-equipment configurations.

There is nothing to build, nothing to solder, and nothing but the speakers included with the platform to hook up.

1.3 TPA005D14 Class-D EVM Specifications

All measurements made with $V_{DD} = 5\text{ V}$ and $R_L = 4\ \Omega$, unless otherwise noted.

1.3.1 Maximum

Supply voltage range, V_{DD}	4.5 V to 5.5 V
Supply current, I_{DD}	2.3 A
Continuous output power per channel, BTL, P_O	2 W
Continuous output power per channel, headphones, P_O : 32- Ω SE	50 mW
Audio input voltage, class-D, V_I	280 mVrms
Audio input voltage, headphone, V_I	1.6 Vrms

1.3.2 Typical

Supply current, no input, class-D active, I_{DD}	35 mA
Supply current, no input, headphone active, I_{DD}	10 mA
Supply current, EVM mute, class-D active, I_{DD}	2.5 mA
Supply current, EVM mute, headphone active, I_{DD}	2 mA
Supply current, EVM shutdown, I_{DD}	50 μ A
Gain, class-D	20 dB
Gain, headphone	0 dB
Crosstalk, class-D, $P_O = 2\text{ W @ }1\text{ kHz}$	-60 dB
Crosstalk, headphone, $P_O = 30\text{ mW @ }1\text{ kHz}$	-70 dB
Total harmonic distortion + noise, class-D, $P_O = 1\text{ W @ }1\text{ kHz}$	0.1 %
Total harmonic distortion + noise, headphone, $P_O = 30\text{ mW @ }1\text{ kHz}$	0.3 %

Quick Start

Follow the steps in this chapter to quickly prepare the TPA005D14 class-D stereo audio amplifier EVM for use. Using the TPA005D14 class-D EVM with the TI plug-n-play audio amplifier evaluation platform is a quick and easy way to connect power, signal and control inputs, and signal outputs to the EVM using standard connectors. However, the audio amplifier evaluation module can be used stand-alone by making connections directly to the module pins, and it can be wired directly into existing circuits or equipment.

The platform switch and jumper settings shown in Table 2–1 are typical for the TPA005D14 class-D EVM. There are no jumpers or switches to set on the TPA005D14 class-D EVM board, itself.

Table 2–1. Typical TI Plug-N-Play Platform Jumper and Switch Settings for the TPA005D14 Class-D EVM

POWER TYPE (Note 2)	JP4	JP5	JP6	JP7	JP8	S1	S2 (Note3)	S3
VDD (J6)	X	ON	Mute	X	Lo	X	OFF	U5

- Notes:**
- 1) ON = Jumper installed, OFF = Jumper **NOT** Installed, X = Don't care
 - 2) Unregulated and battery sources must have a voltage regulator EVM (SLVP097) installed in platform socket U6 (see table 3–4, Section 3.5.5 for these options).
 - 3) Set to ON when tone control board SLOP109 is installed in U1.

Topic	Page
2.1 Precautions	2–2
2.2 Quick Start List for Platform	2–3
2.3 Quick Start List for Stand-Alone	2–5

2.1 Precautions

Power Supply Input Polarity and Maximum Voltage

Always ensure that the polarity and voltage of the external power connected to V_{CC} power input connector J1, J2, and/or V_{DD} power input connector J6 are correct. Overvoltage or reverse-polarity power applied to these terminals can open onboard soldered-in fuses and cause other damage to the platform, installed evaluation modules, and/or the power source.

Inserting or Removing EVM Boards

Do not insert or remove EVM boards with power applied — damage to the EVM board, the platform, or both may result.

Figure 2–1. Quick Start Platform Map

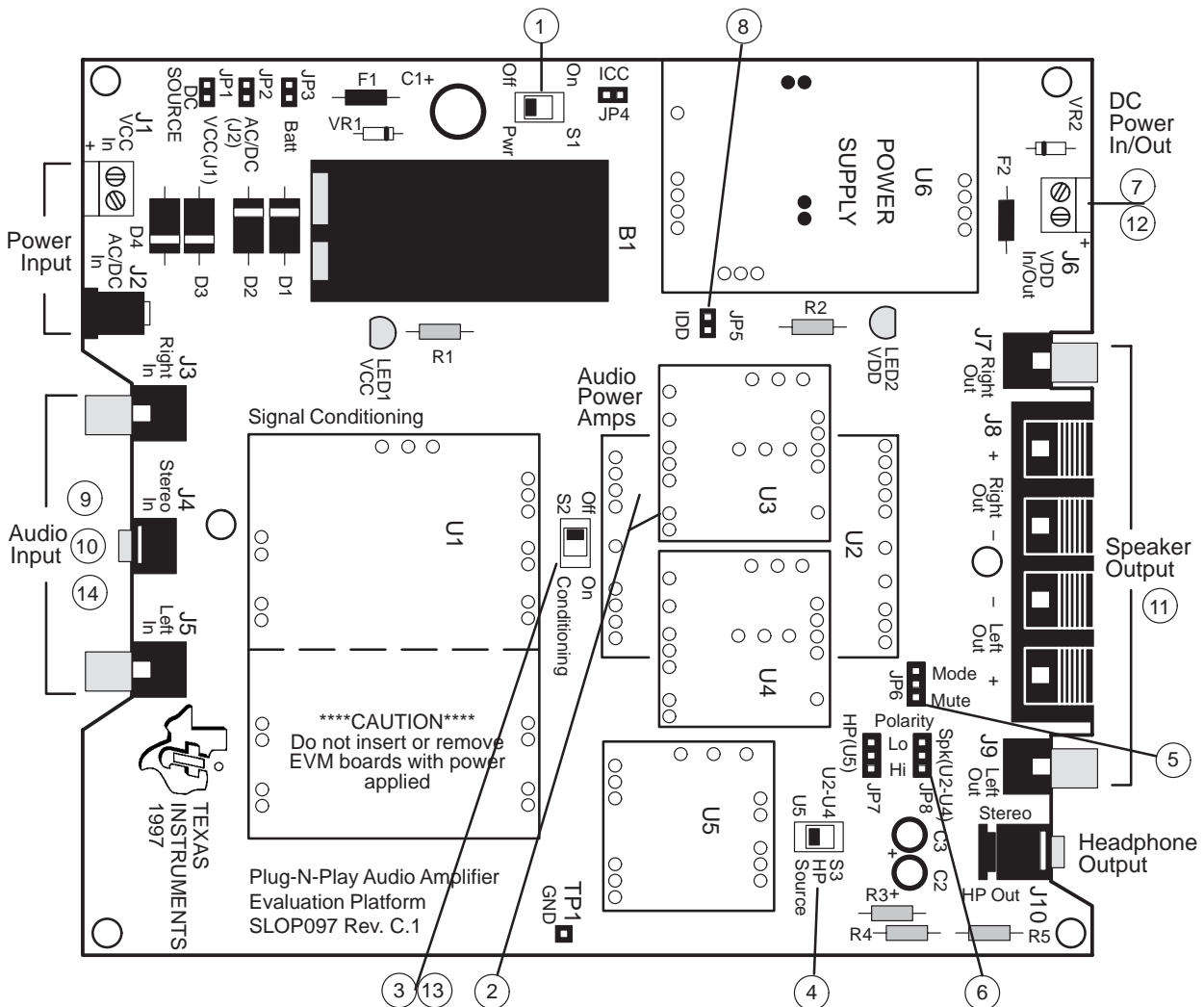

2.2 Quick Start List for Platform

Follow these steps when using the TPA005D14 class-D EVM with the TI plug-n-play audio amplifier evaluation platform (see the platform user's guide, SLOU011, for additional details). Numbered callouts for selected steps are shown in Figure 2–1 and details appear in Chapter 3.

Platform Preparations

- 1) Ensure that all external power sources are set to **OFF**.
- 2) Install a TPA005D14 module in platform socket **U2**, taking care to align the module pins correctly (EVM power pins engage sockets U2 and U3).
- 3) Set switch **S2** to **OFF**.
- 4) Set switch **S3** to **U5**.
- 5) Set jumper **JP6** to select the **Mute** control input.
- 6) Set control signal **Polarity** jumper **JP8** to **Lo**.

Table 2–2. Platform Jumper and Switch Settings for the TPA005D14

POWER TYPE (Note 2)	JP4	JP5	JP6	JP7	JP8	S1	S2 (Note 3)	S3
VDD (J6)	X	ON	Mute	X	Lo	X	OFF	U5

- Notes:**
- 1) ON = Jumper installed, OFF = Jumper **NOT** Installed, X = Don't care
 - 2) Unregulated and battery sources must have a voltage regulator EVM (SLVP097) installed in platform socket U6.
 - 3) Set to ON when tone control board SLOP109 is installed in U1.

Power supply

- 7) Connect a **5-V** regulated power supply (ensure power supply is set to **OFF**) to **J6**, taking care to observe marked polarity.
- 8) Set jumper **JP5** for VDD power to EVMs.

Inputs and outputs

- 9) Ensure that the audio signal source level is set to minimum.
- 10) Connect the audio source to left and right RCA phono jacks **J3** and **J5** or stereo miniature phone jack **J4**.
- 11) Connect 4-Ω – 8-Ω speakers to left and right RCA jacks **J7** and **J9** or to stripped wire speaker connectors **J8**.

Power up

- 12) Verify correct voltage and input polarity and set the external power supply to **ON**.

Platform LED2 should light indicating the presence of V_{DD} , and the evaluation module(s) installed on the platform should begin operation.

- 13) Set switch S2 to ON if tone control board SLOP109 is installed in **U1**.
- 14) Adjust the signal source level as needed.

2.3 Quick Start List for Stand-Alone

Follow these steps to use the TPA005D14 class-D EVM stand-alone or to connect it into existing circuits or equipment. Connections to the TPA005D14 module header pins can be made via individual sockets, wire-wrapping, or soldering to the pins, either on the top or the bottom of the module circuit board.

❑ Power supply

- 1) Ensure that all external power sources are set to **OFF**.
- 2) Connect an external regulated power supply set to **5 V** to the module **VDD**, **VDD2**, and **GND** pins taking care to observe marked polarity. It is only necessary to use the ground pins adjacent to the module power pins.

❑ Inputs and outputs

- 3) Ensure that audio signal source level adjustments are set to minimum.
- 4) Connect the audio source to the module **RIN+/RIN-** and **LIN+/LIN-** pins for class-D operation, taking care to observe marked polarity. For single-ended input, the negative input pins (**RIN-** and **LIN-**) should be connected to the ground of the audio signal source.
- 5) Connect a control signal to the module **Mode** pin, if necessary. The control signal should be low (or tied to ground) for class-D operation, or high (2 V to 5 V) to activate the headphone circuit. Ensure that a headphone is plugged into module headphone jack J1 if controlling the **Mode** pin externally.
- 6) Connect a control signal to the module **Mute** pin, if necessary. The control signal should be high (2 V to 5 V or left floating) for normal operation, or low (tied to ground) to mute the output.
- 7) Connect a control signal to the module **SD** pin, if necessary. The control signal should be high (2 V to 5 V or left floating) for normal operation, or low (tied to ground) to shut down the TPA005D14 amplifier IC on the EVM.

Note that the control signals applied to the EVM mode, mute, and SD inputs must have sufficient current capability to overcome the 100-k Ω pullup resistor on each input. Miniature pushbutton switches on the EVM allow manual shutdown (**S1**) and manual muting (**S2**) of the amplifier.

- 8) Connect a 4- Ω – 8- Ω speaker to the module **Rout+/Rout-** pins and another speaker to the **Lout+/Lout-** pins, taking care to observe marked polarity.

❑ Power up

- 9) Verify correct voltage and input polarity and set the external power supply to **ON**.

The EVM should begin operation.

- 10) Adjust the signal source level as needed.

Details

This chapter provides details on the TPA005D14 IC, the evaluation module, and the steps in the Quick-Start list, a discussion of class-D amplifiers, additional application information, a parts list for the TPA005D14 class-D evaluation module, module performance graphs, and module PCB layer illustrations.

Topic	Page
3.1 Precautions	3-2
3.2 The TPA005D14 Class-D Audio Power Amplifier EVM	3-3
3.3 Class-D Amplifier Design Considerations	3-10
3.4 Using The TPA005D14 Class-D EVM With the P-N-P Platform	3-11
3.5 Using The TPA005D14 Class-D EVM Stand-Alone	3-18
3.6 TPA005D14 Class-D EVM Performance Characteristics	3-20
3.7 TPA005D14 Class-D EVM Interconnects	3-27
3.8 TPA005D14 Class-D Evaluation Module Parts List	3-28
3.9 TPA005D14 Class-D EVM Schematic	3-29
3.10 TPA005D14 Class-D EVM PCB Layers	3-30

3.1 Precautions

Power Supply Input Polarity and Maximum Voltage
 Always ensure that the polarity and voltage of the external power connected to V_{CC} power input connector J1, J2, and/or V_{DD} power input connector J6 are correct. Overvoltage or reverse-polarity power applied to these terminals can open onboard soldered-in fuses and cause other damage to the platform, installed evaluation modules, and/or the power source.

Inserting or Removing EVM Boards
 Do not insert or remove EVM boards with power applied — damage to the EVM board, the platform, or both may result.

Figure 3–1. The TI Plug-N-Play Audio Amplifier Evaluation Platform

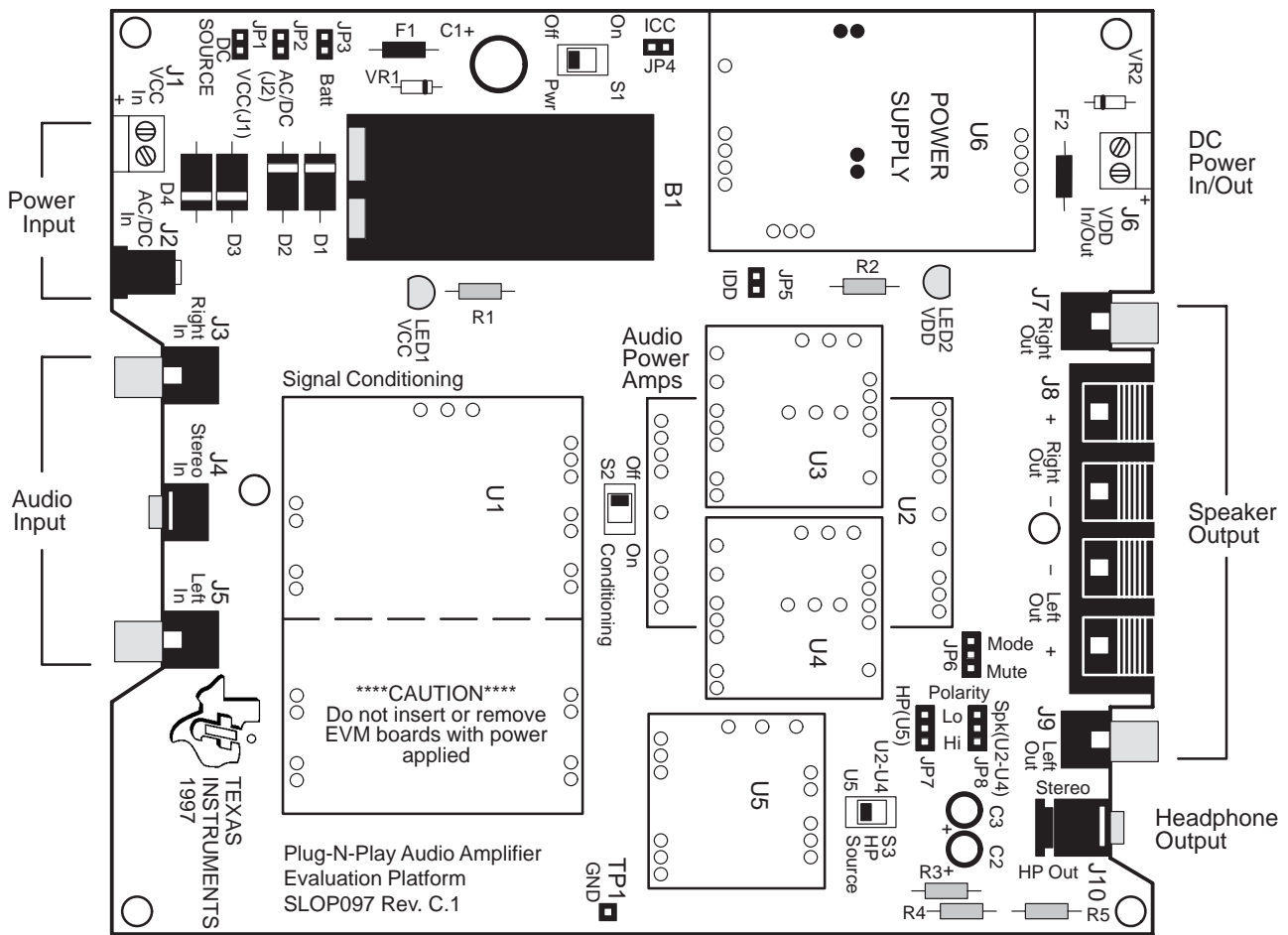

3.2 The TPA005D14 Class-D Audio Power Amplifier Evaluation Module

The TPA005D14 class-D stereo audio power amplifier evaluation module is powered by a TPA005D14 class-D stereo power amplifier integrated circuit. The EVM is capable of delivering greater than 2 W of continuous average power per channel into 4- Ω loads at less than 0.6% THD+N over a 20-Hz to 20-kHz frequency range from a 5-V supply. The TPA005D14 amplifier IC includes a separate internal 50-mW class-AB headphone amplifier circuit and the necessary interface logic to select between the class-D and headphone modes of operation.

The TPA005D14 amplifier IC operates in the bridge-tied load (BTL) mode for maximum efficiency during class-D operation. The high IC switching frequency reduces the size of the output filter to three small capacitors and two small inductors per class-D channel. The evaluation module includes onboard pushbutton switches for manual muting and shutdown, and input pins for logic control of mode, mute, and shutdown. A miniature stereo headphone jack is mounted on the EVM board for convenient connection of headphones. The jack has switch contacts and the module includes related circuitry to switch the amplifier IC to the headphone mode when a headphone plug is inserted into the jack.

The module can be used with the TI plug-n-play audio amplifier evaluation platform (Figure 3–1) or wired directly into circuits or equipment. The module has single in-line header connector pins mounted to the underside of the board. These pins allow the module to be plugged into the platform, which automatically makes all the signal input and output, power, and control connections to the module.

The module connection pins are on 0.1-inch centers to allow easy use with standard perf board and plug board-based prototyping systems. Or, the EVM can be wired directly into existing circuits and equipment when used stand-alone.

The module appears in Figure 3–2 (top side) and Figure 3–3 (bottom side), and its schematic is shown in Figure 3–4. Note that several components are mounted on the bottom side of the EVM PCB.

Figure 3–2. The TI TPA005D14 Class-D Stereo Audio Power Amplifier EVM — Top View

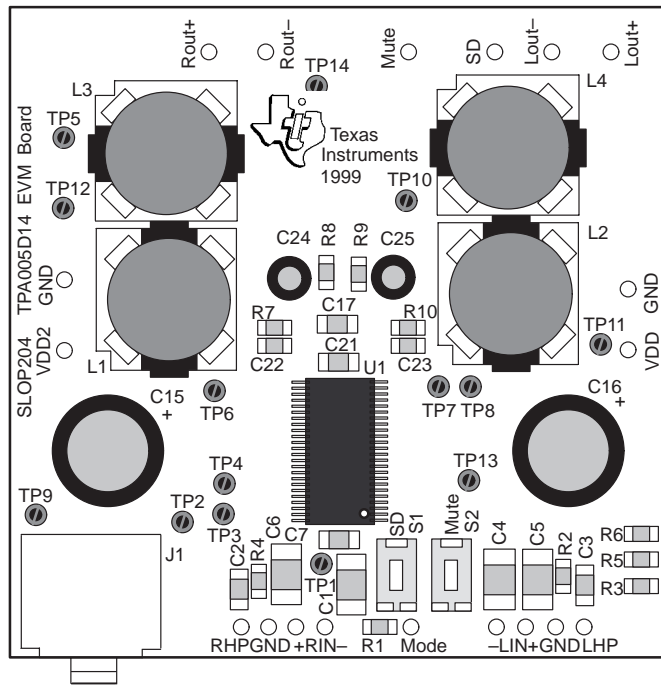

Figure 3–3. The TI TPA005D14 Class-D Stereo Audio Power Amplifier EVM — Bottom View

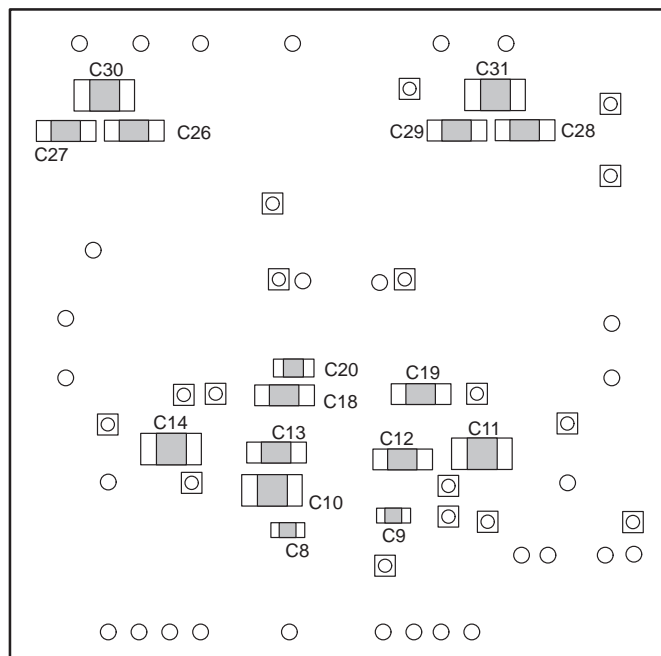
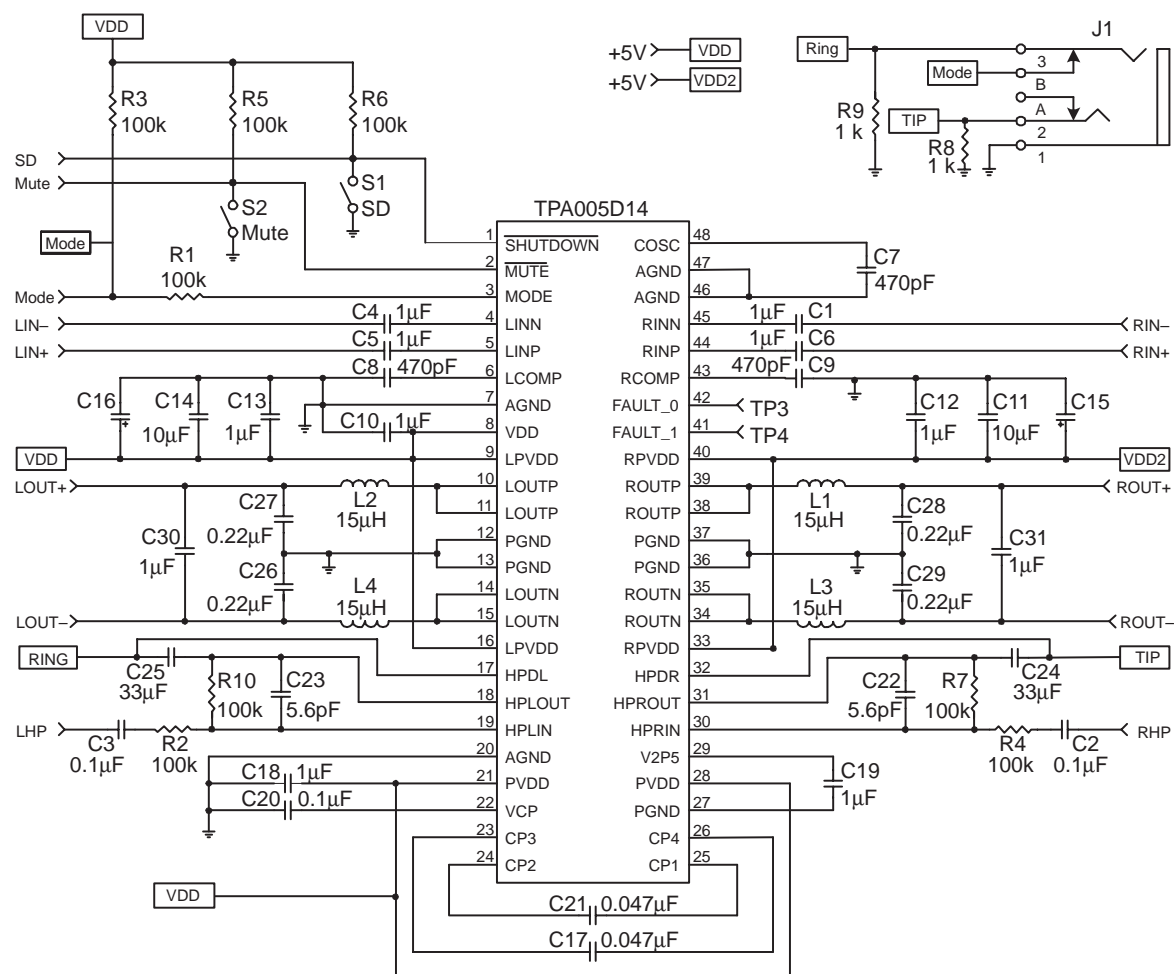

Figure 3–4. TPA005D14 Class-D EVM Schematic Diagram



3.2.1 TPA005D14 Class-D Stereo Audio Amplifier IC

The TPA005D14 class-D stereo audio power amplifier integrated circuit converts low-level audio into pulse-width-modulated (PWM) signals, which result in an audio output with a 20-dB increase in amplitude. The IC features high-current DMOS output transistors and internal feedback that provides excellent performance without the need for external components (beyond input isolation and output filtering).

A full range of protection features are built into the TPA005D14 amplifier IC to increase device reliability: thermal, overcurrent, and undervoltage shutdown, with status terminals that report any error conditions encountered.

The device is provided in a very small 48-pin thermally-enhanced PowerPAD TSSOP surface-mount package (DCA) and consumes only 1 μ A in the shutdown mode, making the TPA005D14 an excellent choice for portable battery-powered applications.

3.2.2 Overview of Class-D Audio Amplifiers

Class-D audio amplifiers are very similar in operation to switch-mode power supplies in that both compare an input signal with a reference to create an error voltage that controls a pulse-width modulator (PWM) circuit. The PWM circuit then produces an output signal at constant frequency and with a duty cycle that varies according to the input signal. A block diagram of the major components that make up the amplifier is shown in Figure 3–5.

Figure 3–5. Class-D Functional Diagram

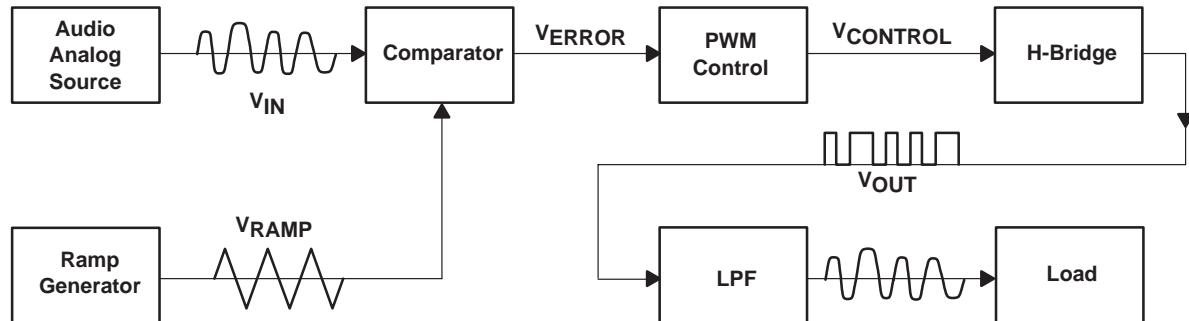

The audio input signal (V_{IN}) is applied to a very fast comparator along with a ramp signal (V_{RAMP}) created by the ramp generator. Each time the triangle wave from the ramp generator crosses the audio input signal level, the comparator sends an error signal (V_{ERROR}) to the PWM control circuit. The PWM control signal ($V_{CONTROL}$) then regulates the duty cycle of the high-current DMOS power transistors of the H-bridge, providing the output signal (V_{OUT}).

These transistors operate in either the cutoff or saturated regions, rather than the linear region, which is where class AB amplifiers operate. This reduces switching and conduction losses, reducing the power dissipated by the power transistors and allowing more power to be delivered to the load. An inductor-capacitor (LC) low-pass filter (LPF) then removes the high frequency switching component from V_{OUT} , leaving an amplified version of the original input signal. Examples of these waveforms are shown in Figure 3–6.

Figure 3–6. Class-D Input and Output Waveforms

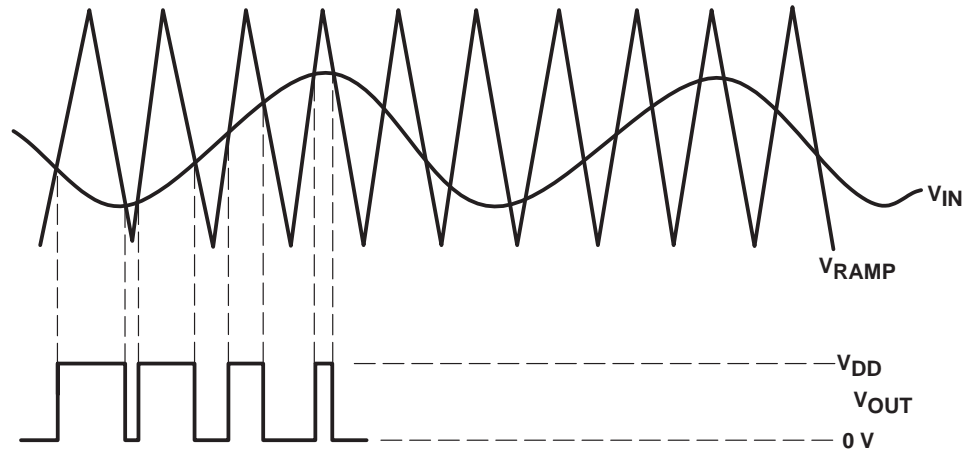

The V_{RAMP} signal must be at a much higher frequency than the highest frequency component of V_{IN} to obtain an accurate representation at the low-pass filter output and allow greater attenuation of the switching component of V_{OUT} . The TPA005D14 class-D EVM uses a 250 kHz V_{RAMP} signal to sample V_{IN} . This frequency is more than ten times higher than the highest frequency component of the 20 Hz to 20 kHz range of the audio input, providing excellent output resolution and easy filtering by the LPF.

3.2.3 Bridge-Tied Load (BTL) Operation

The DMOS output transistors of the TPA005D14 class-D amplifier IC are arranged in an H-bridge configuration to allow BTL operation. In the BTL output mode, each half of the H-bridge operates 180° out of phase from the other. The load, in this case, a speaker, is then connected between the two halves, and is not connected directly to ground. The load is, in a sense, floating.

BTL operation has two main advantages over single-ended operation. First, it eliminates the need for a bulky output coupling capacitor to block any dc offset voltage that may be present (which reduces the speaker response and may damage the speaker). And second, it quadruples the output power that can be delivered to the load. For more information, see the TPA005D14 amplifier IC data sheet, TI Literature Number SLOS240.

To operate in the BTL output mode, the EVM output signal from Rout+/Lout+ must go through the speaker load and be returned directly to Rout-/Lout-, and **NOT** to system ground. This requires that the Rout-/Lout- lines be isolated not only from system ground, but also from each other and the out- lines of any other amplifiers in the system. The plug-n-play platform provides such isolated output lines, connecting the EVM output pins directly to left and right speaker connectors.

3.2.4 Class-D Differential and Headphone Single-Ended Inputs

The TPA005D14 EVM line inputs allow the use of a single-ended or differential audio source. The differential input stage of the amplifier cancels any noise that appears on both input lines of a channel. To use the EVM with a differential source, connect the positive lead of the audio source to the RIN+/LIN+ inputs and the negative lead to the RIN-/LIN- inputs. To use the EVM with a single-ended source, connect the positive lead of the audio source to the RIN+/LIN+ inputs and the ground lead to the RIN-/LIN- inputs. This ac grounds the input capacitors on the negative terminals and balances the input impedance of the class-D amplifier's positive and negative input terminals, preventing voltage differences that result in popping in the speakers.

The headphone inputs are for single-ended connections, with the positive leads connected to the RHP and LHP inputs. For best results, the ground of the signal source should be connected to the GND pins at the EVM inputs. This provides a ground return path for the current.

3.2.5 Control and Indicator Circuits

Three main control circuits are provided with the TPA005D14. The mode circuit selects which amplifier is active, the mute circuit grounds the output of the active amplifier, and the shutdown circuit places the entire device into a power-saving sleep mode to minimize current consumption. Each of these inputs is TTL compatible: less than 0.8 V applied to these pins is considered a logic low, and any voltage greater than 2 V is considered a logic high.

Two indicator pins are also provided for feedback when an under-voltage, over-current, or thermal fault exists. Module pins are provided for easy connection of off-board control and monitoring. Signals on these pins provide the status of the class-D amplifier: operational, over-current, thermal fault, and under-voltage lockout. The only status reported for the class-AB headphone amplifier is for a thermal fault, indicated by the same error code as for the class-D amplifier. Table 3–1 lists the possible output conditions of these pins and a description of the fault indicated.

Table 3–1. TPA005D14 Class-D EVM Fault Indicator Table

FAULT 0 (TP 2)	FAULT 1 (TP 3)	DESCRIPTION
1	1	No fault. — The device is operating normally.
1	0	Charge pump under-voltage lockout (VCP-UV) fault — the charge pump voltage is < (PVDD + 6V). All low-side transistors are turned on, shorting the load to ground. Normal operation resumes when the charge pump voltage is restored (not a latched fault), however the Fault <i>indication</i> remains active until cleared by cycling MUTE, SHUTDOWN, or the power supply.
0	1	Over-current fault — the output current limit has been exceeded. All output transistors are switched off, causing the load to see a high impedance state. This is a <i>latched</i> fault and is cleared by cycling MUTE, SHUTDOWN, or the power supply.
0	0	Thermal fault — the internal junction temperature has exceeded 125°C. All of the low-side transistors are turned on, shorting the load to ground. Once the junction temperature drops by 20°C and is below 125°C, normal operation resumes (not a latched fault). The Fault <i>indication</i> remains active until cleared by cycling MUTE, SHUTDOWN, or the power supply.

3.2.6 TPA005D14 Class-D EVM Test Points

Test points have been included on the TPA005D14 class-D EVM to facilitate user analysis of device performance and design adjustments. Table 3–2 lists each test point and its corresponding function.

Table 3–2. TPA005D14 Class-D EVM Test Points

TEST POINT	IC PIN or EVM FUNCTION	FUNCTION
1	COSC	Ramp generation capacitor input and output
2	J1–2 (Tip)	Headphone right channel output
3	FAULT_0	LSB for logic-level fault output signal, open drain
4	FAULT_1	MSB for logic-level fault output signal, open drain
5	ROUTN	Class-D right channel negative output of the H-bridge
6	ROUTP	Class-D right channel positive output of the H-bridge
7	VCP	Charge pump storage capacitor
8	LOUTP	Class-D left channel positive output of the H-bridge
9	J1–3 (Ring)	Headphone left channel output
10	LOUTN	Class-D left channel negative output of the H-bridge
11	VDD	Probe VDD power input connections
12	VDD2	Probe VDD2 power input connections
13	N/A	Probe ground connections
14	N/A	Probe ground connections

3.3 Class-D Amplifier Design Considerations

Detailed information for proper design and implementation of TI class-D audio power amplifiers is located in the application report *Design Considerations for Class-D Audio Power Amplifiers*, TI Literature Number SLOA031, on the TI website (<http://www.ti.com/sc/apa>). This report provides background information, general equations, and component selection criteria for the topics listed below. General layout considerations are also included in the report.

- Class-D amplifier circuits (input, output, charge pump, and switching)
- Headphone circuit
- Control and indicator circuits
- Power supply decoupling

The application report *Reducing and Eliminating the Class-D Output Filter*, TI Literature Number SLOA023, is also available from the website, and provides information to help determine what type of output filter, if any, may be necessary.

3.4 Using The TPA005D14 Class-D EVM With the Plug-N-Play Platform

The TPA005D14 class-D stereo audio amplifier evaluation module was designed to be used with the TI plug-n-play audio amplifier evaluation platform. It simply plugs into socket U2 and U3.

The following paragraphs provide additional details for using the TPA005D14 class-D EVM with the platform.

3.4.1 Installing and Removing EVM Boards

TI plug-n-play evaluation modules use single-in-line header pins installed on the underside of the module circuit board to plug into sockets on the platform. The EVM pins and the platform sockets are keyed such that only the correct type of EVM can be installed in a particular socket, and then only with the proper orientation.

Evaluation modules are easily removed from the platform by simply prying them up and lifting them out of their sockets. Care must be taken, however, to prevent bending the pins.

3.4.1.1 EVM Insertion

- 1) Remove all power from the evaluation platform.
- 2) Locate sockets U2 and U3 on the platform.
- 3) Orient the module correctly.
- 4) Carefully align the pins of the module with the socket pin receptacles.
- 5) Gently press the module into place.
- 6) Check to be sure that all pins are seated properly and that none are bent over.

3.4.1.2 EVM Removal

- 1) Remove all power from the evaluation platform.
- 2) Using an appropriate tool as a lever, gently pry up one side of the module a small amount.
- 3) Change to the opposite side of the module and use the tool to pry that side up a small amount.
- 4) Alternate between sides, prying the module up a little more each time to avoid bending the pins, until it comes loose from the socket.
- 5) Lift the EVM off of the platform.

3.4.2 Module Switches

The TPA005D14 class-D stereo audio amplifier evaluation module is equipped with two pushbutton switches that allow the module shutdown and mute functions to be manually activated.

3.4.2.1 S1 — Shutdown

To have the module amplifier IC enter the shutdown mode, press the shutdown switch (S1) on the module. S1 connects the amplifier IC $\overline{\text{SHUTDOWN}}$ pin to ground, forcing it into a low-power state. This function can be controlled by an external control input to the SD module pin.

The shutdown mode reduces the amplifier IC current consumption to approximately 1 μA compared to approximately 2.5 mA in the mute mode. The EVM shutdown current is based on V_{DD} , R6, and capacitor leakage currents, but will typically be 50 $\mu\text{A} \pm 5\%$ for $V_{\text{DD}} = 5\text{ V}$. The plug-n-play platform typically draws 23 mA of current.

3.4.2.2 S2 — Mute Switch

Pushbutton switch S2 on the TPA005D14 class-D EVM allows manual muting of the amplifier IC. S2 connects the amplifier IC $\overline{\text{MUTE}}$ pin to ground, muting the output. The EVM Mute control input pin also allows external control of this function.

In the mute mode, the amplifier IC lowside output transistors are turned on, shorting the load to ground. This reduces the EVM current to 2.5 mA in the class-D mode and to 2 mA in the class-AB headphone amplifier mode.

3.4.3 Signal Routing

Signal flow on the platform is controlled by two signal routing switches, as shown in Figure 3–7.

Figure 3–7. Platform Signal Routing and Outputs

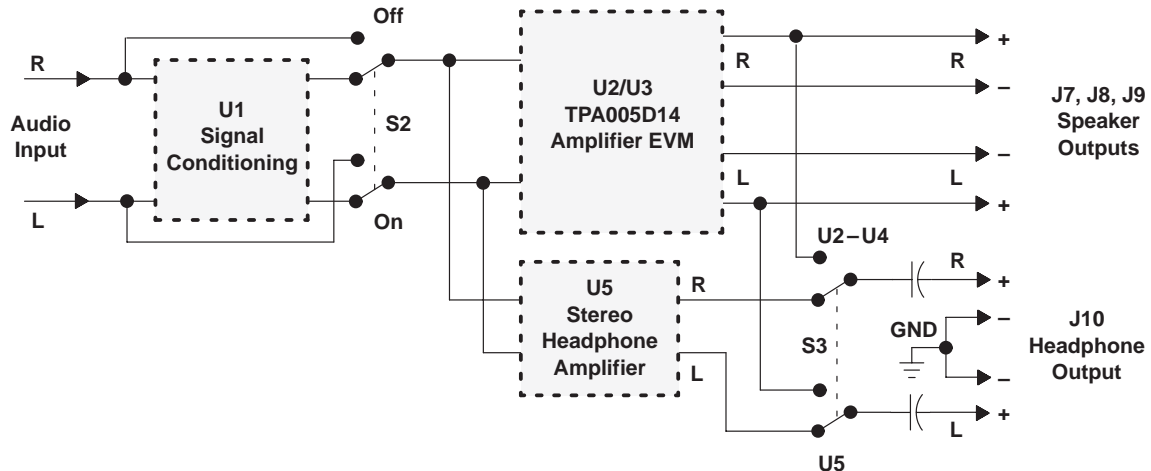

3.4.3.1 Signal Conditioning

The audio signal from input jacks can be applied to the signal conditioning socket (U1) if an EVM is installed there, or socket U1 can be bypassed and the audio input signal applied directly to the inputs of the TPA005D14 class-D EVM.

- Platform switch **S2** selects signal conditioning or bypasses it.

3.4.3.2 Headphone Output Jack

Switch S3 is the source select for the stereo headphone output jack, J10. The headphone jack is capacitively coupled (via 470 μ F electrolytics) and can output either the signal from the headphone amplifier in socket U5, or the signal from the power amplifier installed in socket U2, as determined by the setting of headphone source select switch S3.

- The platform headphone output jack (J10) is not used in conjunction with the TPA005D14 class-D EVM. Switch **S3** should be set to the **U5** position when the TPA005D14 class-D EVM is installed on the platform.

3.4.4 Shutdown

The TPA005D14 class-D EVM is equipped with a shutdown control input pin. When this input is tied to GND, the TPA005D14 amplifier IC on the module enters the shutdown mode and dissipates very little power. When the EVM control input is tied to V_{DD} or allowed to float, amplifier operation resumes.

In typical applications, as often found in notebook computers and other portable audio products, the internal speakers mute when headphones are plugged into the headphone jack, or internal speakers mute when external speakers are connected. In applications using separate speaker and headphone amplifiers, the one not being used can be muted to conserve power.

The TPA005D14 EVM shutdown control pin connects to the platform mute line of JP6 when the EVM is inserted in the plug-n-play platform. When JP6 is set to mute and JP8 is set to Lo, the class-D EVM will operate normally until a headphone plug is inserted into platform jack J10 and the class-D amplifier is placed into shutdown. Once the jack is removed from J10, the class-D EVM again becomes active. Note that when JP6 is set to mute and the class-D EVM shutdown pin is activated, the platform current increases by approximately 20 mA. This current is set by the connection of the 240- Ω platform resistor (R3) to ground through the EVM shutdown switch.

3.4.4.1 Headphone Jack Control Signals

The platform headphone output jack (J10) contains an internal switch that changes the state of a pair of control lines when a plug is inserted (Figure 3–8). Each control line is pulled down by a 1-k Ω resistor to ground (R4 and R5). The switch in the headphone jack pulls one line or the other up to V_{DD} through a 240- Ω resistor (R3) depending on whether a plug is inserted in J10 or not.

Figure 3–8. Mute/Mode and Polarity Control

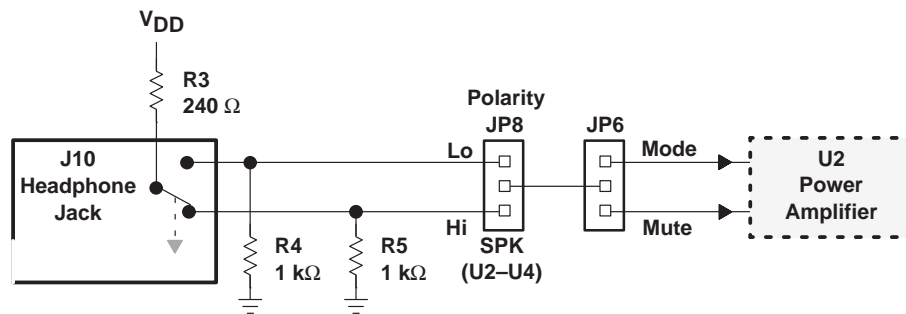

3.4.4.2 Mute/Mode Select (JP6)

A 3-pin jumper header (JP6) on the platform, functioning as an SPDT switch, routes the control signal from the headphone jack to either the mute control input pin or the mode control input pin of the evaluation module.

- Set jumper **JP6** to **MODE** when a separate headphone amplifier is **NOT** installed in **U5**.
- Set jumper **JP6** to **MUTE** when a separate headphone amplifier **IS** installed in **U5**. This will cause the TPA005D14 class-D EVM to shut down when a plug is inserted into platform headphone jack **J10**.

3.4.4.3 Mute/Mode Polarity Select (JP8)

A second 3-pin jumper header (JP8) on the platform selects the control signal polarity by connecting either the active-high or the active-low line from the headphone jack to jumper JP6.

- Set jumper **JP8** to **Lo** for normal class-D operation when a separate headphone amplifier **IS** installed in **U5**.

3.4.5 Power Requirements

The TPA005D14 class-D stereo audio power amplifier evaluation module is designed to operate from a supply voltage between 4.5 V and 5.5 V. For best performance (highest output power with lowest distortion), the module should be operated at 5 V.

The TI plug-n-play audio amplifier evaluation platform provides several options for powering the TPA005D14 class-D EVM. Table 3–3 shows the *platform* jumper and switch settings for each power source option (see the User's Guide for the TI Plug-N-Play Audio Amplifier Platform, TI Literature Number SLOU011 for more information). The TPA005D14 class-D EVM requires no setup for power source selection.

Table 3–3. Platform Jumper and Switch Settings for the TPA005D14 EVM Power Inputs

POWER TYPE (Note 2)	JP1	JP2	JP3	JP4	JP5	JP6	JP7	JP8	S1	S2	S3
VCC (J1)	ON	OFF	OFF	ON	ON	Mode	X	Hi	ON	Note 3	U5
AC/DC (J2)	OFF	ON	OFF	ON	ON	Mode	X	Hi	ON	Note 3	U5
Battery (B1)	OFF	OFF	ON	ON	ON	Mode	X	Hi	ON	Note 3	U5
VDD (J6)	OFF	OFF	OFF	X	ON	Mode	X	Hi	ON	Note 3	U5

- Notes:**
- 1) ON = Jumper installed, OFF = Jumper **NOT** installed, X = Don't care
 - 2) Unregulated and battery sources must have a voltage regulator EVM (SLVP097) installed in platform socket U6.
 - 3) Set to ON when Tone Control Board SLOP109 is installed in U1, otherwise set to OFF.

Although the TPA005D14 amplifier IC draws approximately 0.7 A per channel from the power supply during continuous full power output, peak current draw can be as high as 1.15 A per channel. Any power supply connected to the platform should be capable of providing 2.3 A to avoid clipping of the output signal during voltage peaks. Current consumption driving speakers at normal listening levels is typically 0.1 A or less.

A V_{DD} supply of 5 V is required if a signal processing EVM is installed in platform socket U1 or a separate headphone amplifier EVM is installed in U5. V_{DD} can either be applied to the platform V_{DD} power input terminals (J6) or a voltage regulator (SLVP097 or equiv.) can be installed in platform socket U6 to provide V_{DD} from the platform V_{CC} supply.

The platform is equipped with overvoltage and reverse-polarity supply voltage input protection in the form of fused crowbar circuits.

- V_{DD} voltage applied to platform screw terminals J6 **MUST NOT** exceed the absolute maximum rating for the TPA005D14 amplifier IC installed on the evaluation module (5.5 V) or damage to the IC may result. In no case should V_{DD} voltage of the incorrect polarity or in excess of 6.0 V be applied to screw terminals J6 of the platform, or the power protection circuit on the V_{DD} line will trip.
- V_{CC} voltage applied to the platform **MUST NOT** exceed the maximum voltage input specified for the voltage regulator module installed in socket U6 (12 V for the SLVP097), or damage to the voltage regulator module may result. In no case should V_{CC} voltage applied to the platform exceed 15 V, or the overvoltage protection circuit on the V_{CC} bus will trip.

3.4.6 Inputs and Outputs

The TI plug-n-play audio amplifier evaluation platform is equipped with several standard connectors for audio inputs and outputs.

3.4.6.1 Inputs

In most cases, audio signals enter the platform through either a pair of RCA phono jacks (J3 and J5) or a miniature (1/8") stereo phone jack (J4). Certain signal conditioning and amplifier EVMs, however, may have additional signal input connectors mounted on the module circuit board.

The platform audio signal input jacks (J3, J4, and J5) are of the closed-circuit type, grounding the signal input lines when no plugs are inserted.

3.4.6.2 Outputs

Amplified audio output signals leave the platform through left and right RCA phono jacks (J7 and J9), left and right pairs of compression connectors for stripped speaker wires (J8), and optionally, through a miniature (1/8") stereo phone jack (J10), for headphones.

The audio output lines from the power amplifiers are separate all the way to the edge of the platform (output jacks J7, J8, and J9)—the OUT– lines from the power amplifier sockets are not tied to each other or to platform ground. This allows the TPA005D14 class-D power amplifier EVM to operate in the highly-efficient bridge-tied load configuration when driving speakers.

The headphone jack (J10) is capacitively coupled to source select switch S3, which connects J10 to the output lines of either the headphone amplifier socket or the power amplifier sockets (Figure 3–9).

Figure 3–9. Typical Headphone Plug

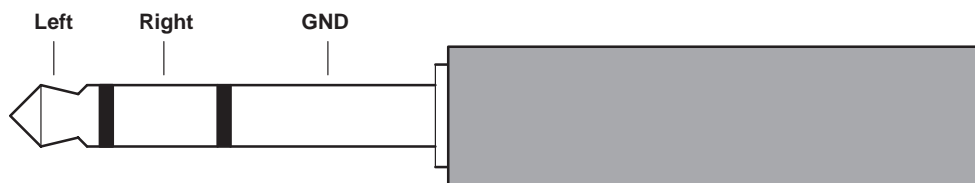

3.5 Using The TPA005D14 Class-D EVM Stand-Alone

Using the TPA005D14 class-D stereo audio power amplifier evaluation module stand-alone is much the same as using it with the platform. The same 4.5-V to 5.5-V power supply range and the isolated out+ and out- lines for BTL operation (Section 3.2.3) requirements exist. Figure 3–10 shows the connections that are required for operation (with the exception of the fault monitor circuit, which is optional). The discussion in this section is in reference to this figure unless otherwise noted.

Figure 3–10. TPA005D14 Class-D EVM Stand-Alone Connections for Stereo BTL Output

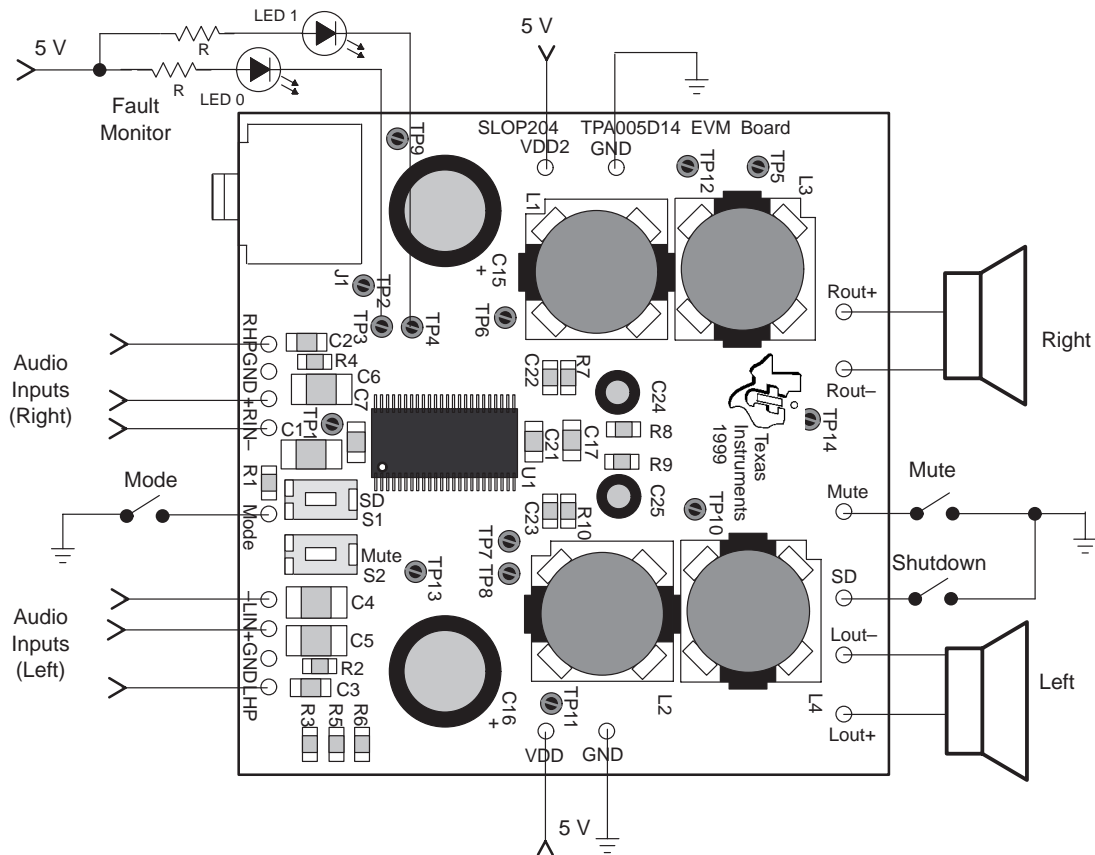

3.5.1 Power Connections

Power must be connected to both the VDD and VDD2 module pins. Power supply ground can be connected to any module ground pin, although best results are achieved if power supply grounds are connected to the pins adjacent to the VDD and VDD2 module pins. The ground and power wires should be twisted to reduce inductance and noise pickup if they are long.

3.5.2 Input Connections

The class-D amplifier input signals can be connected in either of two ways: differential or single-ended. For differential operation, connect the two lines from the signal source to the positive and negative inputs of each channel (RIN+/RIN– and LIN+/LIN– module pins). For single-ended operation, the input signal lines should be connected to the RIN+ and LIN+ module pins and the signal source ground wires should be connected to the RIN– and LIN– module pins. The EVM headphone amplifier inputs are single-ended, and the signal source should be connected to the HPRIN and HPLIN module pins.

For best results, the ground of the signal source should be connected to the GND pins at the EVM inputs to provide a return path for the current. The input signal and ground wires should be twisted to reduce inductance and noise pickup if the lead lengths are long and the cable is not shielded.

3.5.3 Output Connections

The right speaker should be connected between the Rout+ and the Rout– module pins, and the left speaker should be connected between the Lout+ and the Lout– module pins to comply with the isolated output requirements for BTL operation.

3.5.4 Controls and Indicators

The mute and shutdown functions may be controlled externally via the module mute and SD pins. An active-low input mutes the selected amplifier or shuts down the device. A signal of 2 V or higher, or a float condition, allows normal operation.

The mode control selects which amplifier is active and can be controlled in either of two ways. The mode circuit is set to logic low for normal operation (class-D amplifier is active), and the insertion of a headphone plug into the **EVM** headphone jack (J1), switches over to the headphone amplifier (the platform headphone jack is not used in conjunction with the class-D EVM).

When the module mode control input pin is used, the signal must be low for class-D operation and greater than 2 V for headphone amplifier operation.

Note that the mute, mode, and shutdown signals applied to the EVM control input pins must be able to supply enough current to overcome the pullup resistors on the module (100 k Ω).

The fault indicator circuit can be monitored by attaching a pullup resistor to the open-drain outputs of FAULT0 (TP3) and FAULT1 (TP4). The voltage should not exceed 5 V and the current must be limited to less than 1 mA. A fault table is shown in Section 3.2.5 and also in the device data sheet.

3.6 TPA005D14 Class-D EVM Performance Characteristics

The TPA005D14 class-D stereo audio power amplifier EVM was tested using an Audio Precision System II, model 2322, a 5-V regulated dc power supply, and the TI PNP audio power amplifier evaluation platform set up as described in Chapter 2. Class-D results were obtained with 4- Ω and 8- Ω speaker loads and headphone amplifier results were obtained with 32- Ω loads. The results are shown in Figures 3–11 through 3–21.

The frequency response shown in Figure 3–11 is a relatively flat 20 dB over the 20 Hz to 20 kHz frequency range. The lower and upper frequency corners can be adjusted to extend the frequency response.

Figure 3–11. Class-D Amplifier Frequency Response at 4 Ω

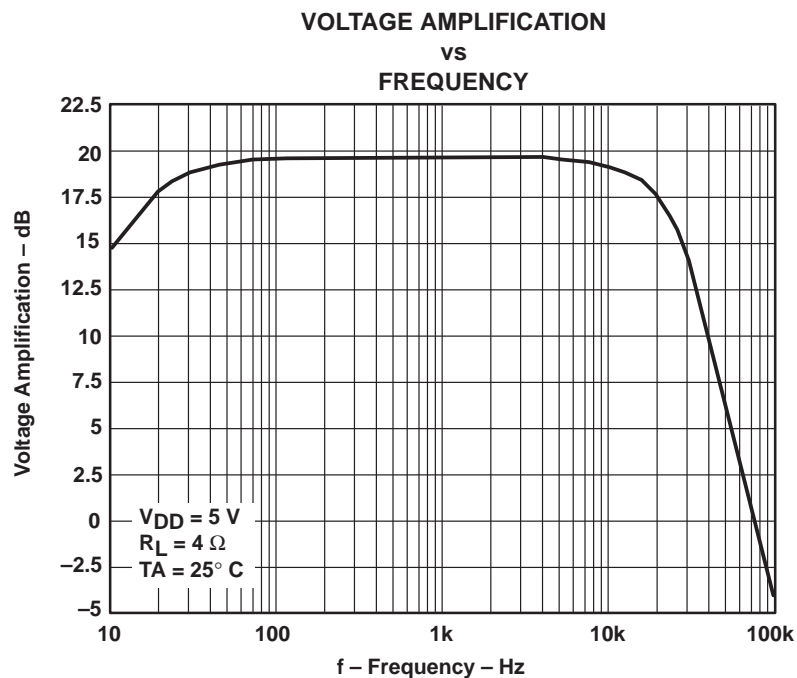

Total harmonic distortion plus noise (THD+N) versus output power and frequency is shown in Figures 3–12 through 3–15 below. Figures 3–12 and 3–13 show power sweeps at a fixed frequency of 1 kHz. Switching and input noise begins to dominate at low power, while the distortion at the mid to upper power levels is a function of the class-D amplifier and the inductor. The lower frequency noise may be improved by either increasing the order of the filter or by increasing the amplifier switching frequency, which will further attenuate the switching noise in the audio band.

Midrange distortion is a combination of the switching noise of the output power transistors in the IC and the magnetic field created by the inductors. This distortion is minimized by good separation of the output filter inductors for each channel and through good EMI-reduction layout techniques.

Figure 3–12. Class-D Amplifier Distortion versus Output Power at 4 Ω

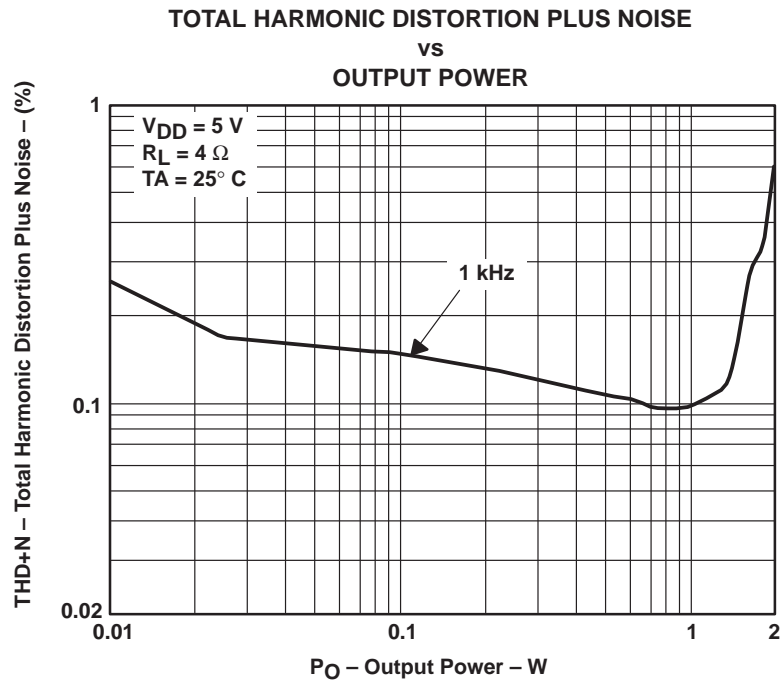
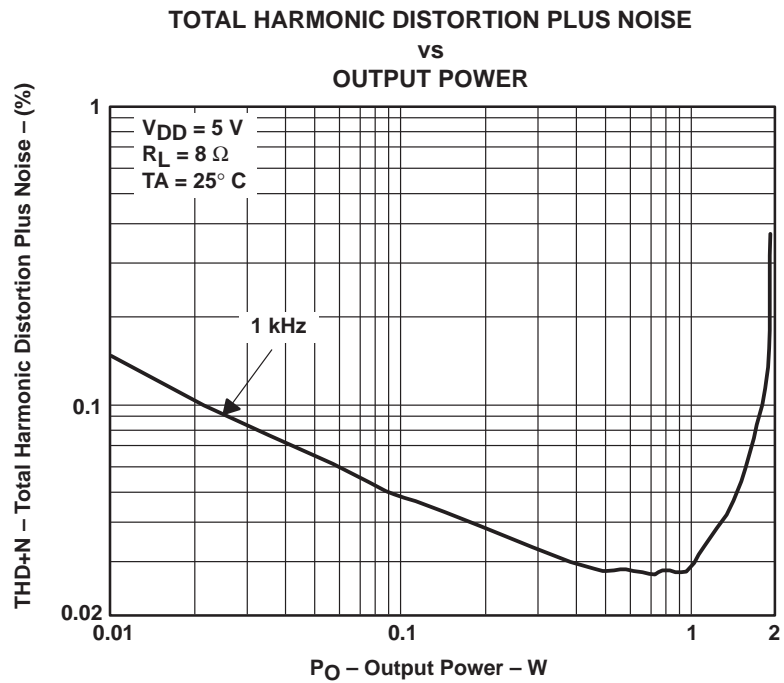

Figure 3–13. Class-D Amplifier Distortion versus Output Power at 8 Ω



Figures 3–14 and 3–15 show a frequency sweep for a 1-W output. The lower frequency distortion of the graphs is dominated by noise, while the distortion at higher frequencies is due primarily to the fast-changing duty cycle of the PWM output.

Figure 3–14. Class-D Amplifier Distortion versus Frequency at 1 W Into 4 Ω

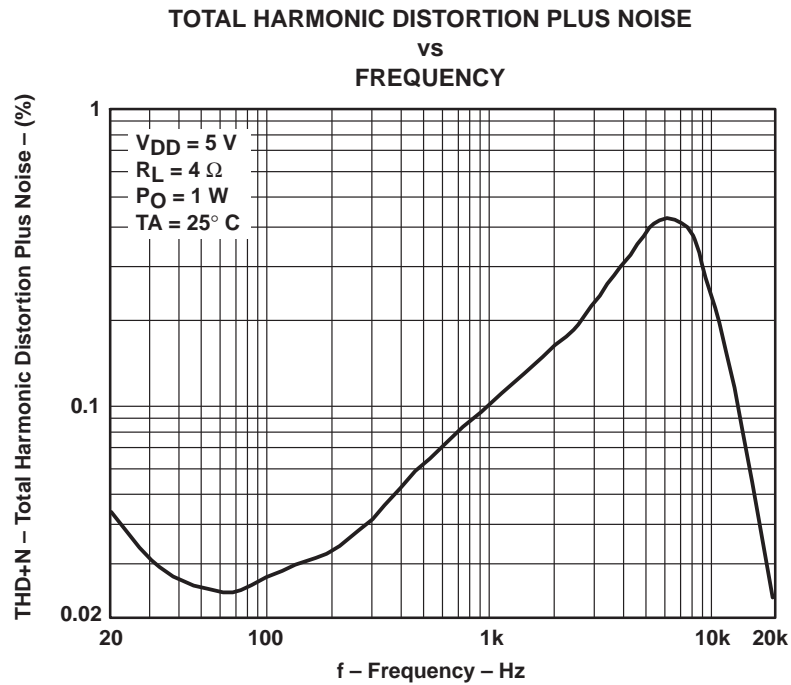
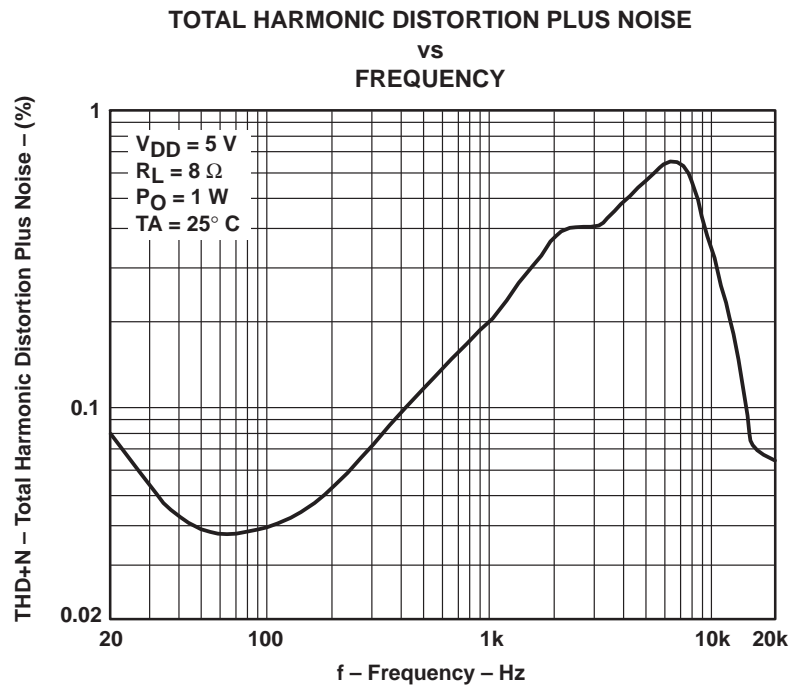

Figure 3–15. Class-D Amplifier Distortion versus Frequency at 1 W Into 8 Ω



EVM crosstalk is shown in Figures 3–16 and 3–17. The frequency is swept from 20 Hz to 20 kHz for a constant 2-W output. Several factors affect crosstalk, such as component selection (especially the inductor), filter layout, grounding, and power supply decoupling.

Figure 3–16. Class-D Amplifier Crosstalk versus Frequency at 2 W Into 4 Ω

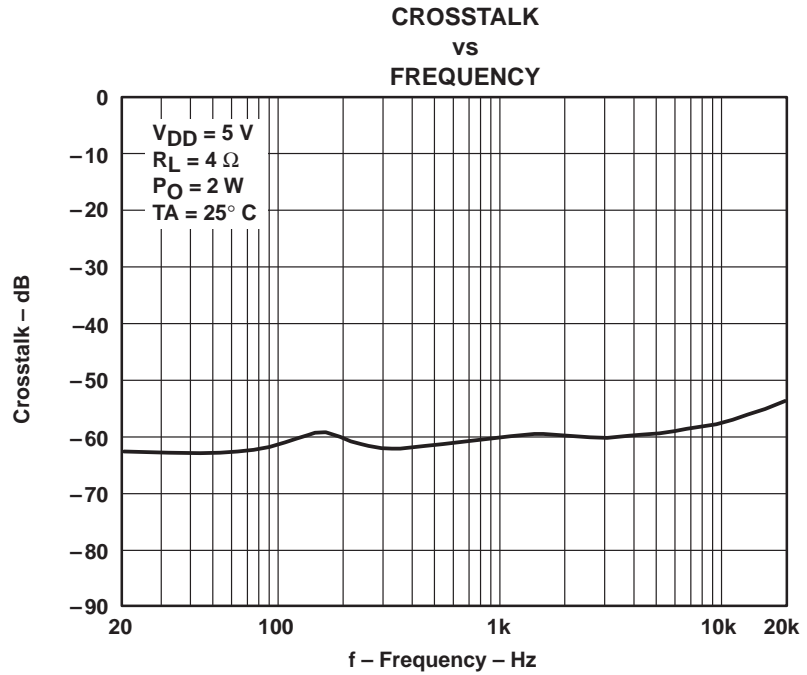
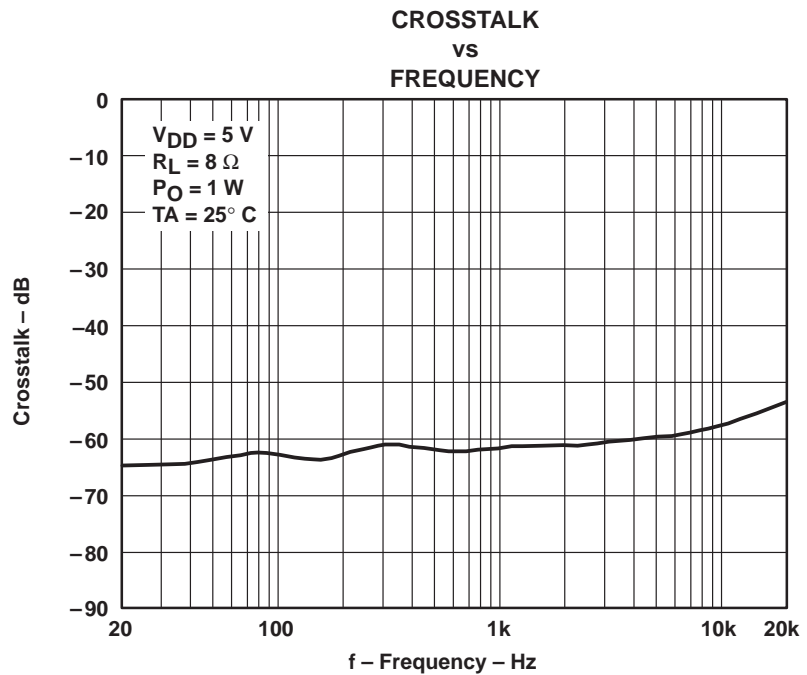
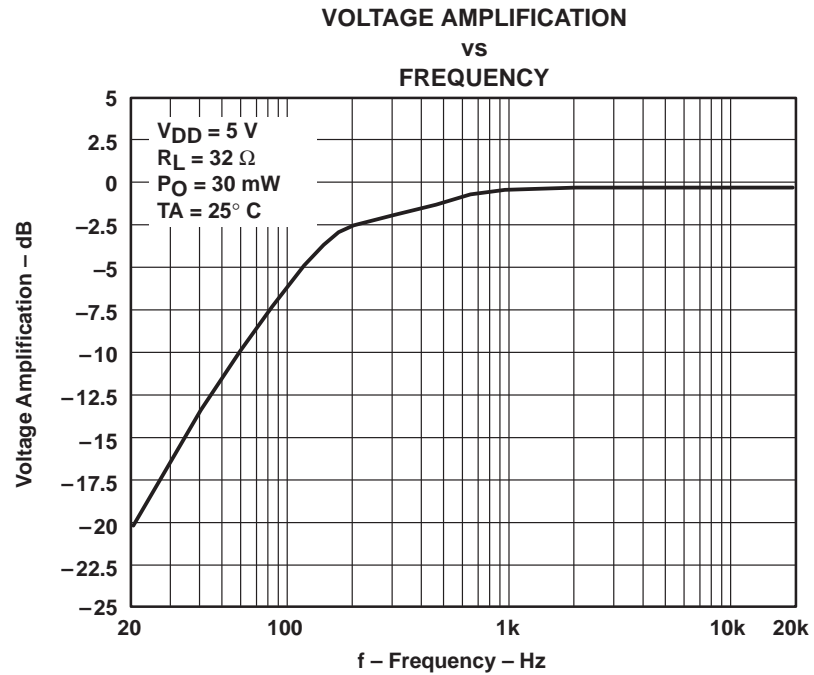

Figure 3–17. Class-D Amplifier Crosstalk versus Frequency at 2 W Into 8 Ω



Headphone amplifier graphs are shown in Figures 3–18 through 3–21 below. The frequency response shown in Figure 3–18 is 0 dB over most of the 20 Hz – 20 kHz frequency range. The sharp rolloff at low frequencies is due to the combination of the two high-pass filters of the circuit (input and output corner frequencies), and can be improved by changing the value of the output filters.

Figure 3–18. Class AB Headphone Amplifier Frequency Response



Total harmonic distortion plus noise (THD+N) versus output power and versus frequency are shown in Figures 3–19 and 3–20. Figure 3–19 shows a power sweep at fixed frequencies of 1 kHz and 20 kHz. The increase in THD for the low frequency sweep is due to noise, and the decrease in THD for the upper frequency sweep is caused by a decrease in harmonics measured.

Figure 3–19. Class AB Headphone Amplifier Distortion versus Output Power

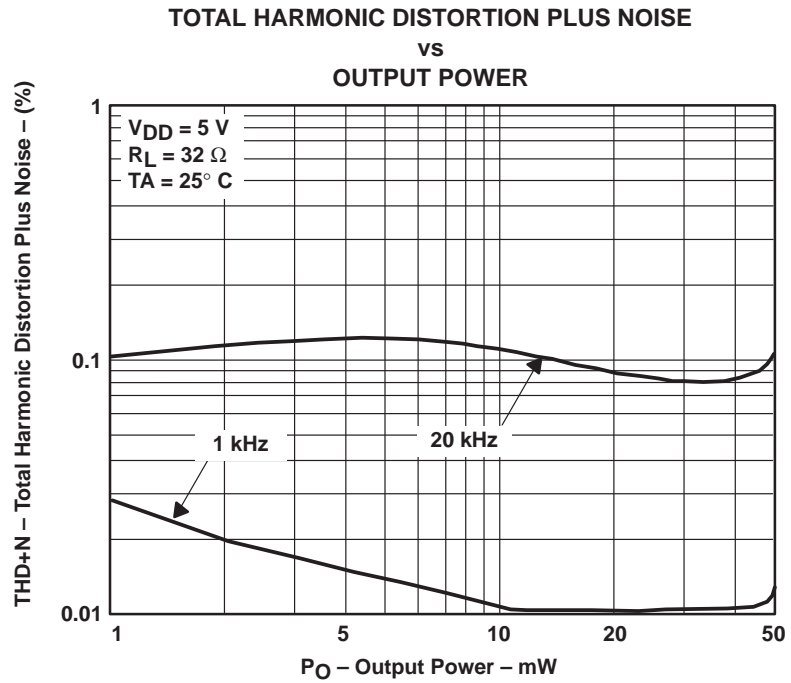
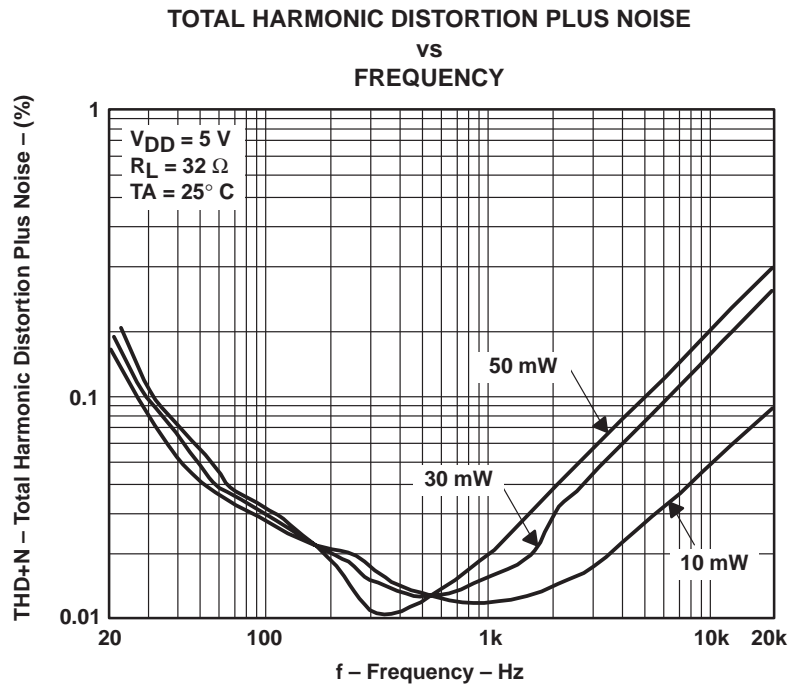

Figure 3–20 shows frequency sweeps for 10-mW, 30-mW, and 50-mW outputs. The lower frequency distortion shown in the graphs is dominated by noise, while the distortion at higher frequencies is caused by inductance in the filter capacitor and trace lengths.

Figure 3–20. Class AB Headphone Amplifier Distortion versus Frequency



EVM crosstalk is shown in Figure 3–21 for an output power of 50 mW.

Figure 3–21. Class AB Headphone Amplifier Crosstalk versus Frequency

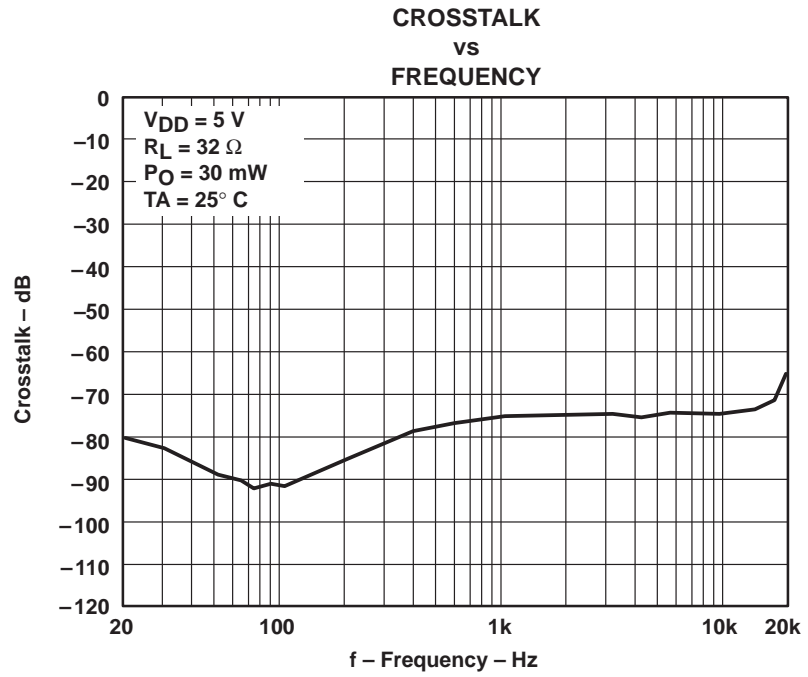

3.7 TPA005D14 Class-D EVM Interconnects

Table 3–4 shows the correlation between the TPA005D14 class-D amplifier IC pins, the EVM pins, and the plug-n-play (PNP) platform sockets.

Table 3–4. TPA005D14 Class-D EVM/Plug-N-Play Platform Interconnects

CLASS-D EVM			PLUG-N-PLAY PLATFORM	
IC PIN	EVM PIN	FUNCTION ON EVM	PNP SOCKET	FUNCTION ON PLATFORM
8, 9 16, 21, 28	VDD	Power for left channel, input, and headphone circuits	VDD	Power from J1, J2, J6, or B1
40, 33	VDD2	Power for right channel circuits	VDD	Power from J1, J2, J6, or B1
7, 12, 13, 20, 27, 36, 37, 46, 47	GND	Analog and power ground for EVM, all pins	GND	Ground for platform from J1, J2, J6, or B1
44	RIN+	Class-D right channel positive input	Right In (line)	Right channel input from J3 or J4
45	RIN–	Class-D right channel inverted input	GND	Ground for platform from J1, J2, J6, or B1
38, 39	Rout+	Class-D right channel positive output	Right Out +	Right channel positive output to J7 or J8
34,35	Rout–	Class-D right channel inverted output	Right Out –	Right channel negative output to J7 or J8
5	LIN+	Class-D left channel positive input	Left In (line)	Left channel input from J4 or J5
4	LIN–	Class-D left channel inverted input	GND	Ground for platform from J1, J2, J6, or B1
10, 11	Lout+	Class-D left channel positive output	Left Out +	Left channel positive output to J8 or J9
14, 15	Lout–	Class-D left channel inverted output	Left Out –	Left channel negative output to J8 or J9
30	RHP	Headphone right channel input	Right In (HP)	Headphone right channel input from J3 or J4
19	LHP	Headphone left channel input	Left In (HP)	Headphone left channel input from J4 or J5
18, 31	J1	Headphone stereo output jack, left and right	NA	Not applicable
3	Mode	Mode control external input pin: class-D active when low, HP active when held > 2 V	N/C	No connect
2	Mute	Mute control external input pin: active low — selected amplifier active when held > 2 V	N/C	No connect
1	SD	Shutdown control external input pin: active low — normal operation when held > 2 V	Mute	Mute control from JP6 for use when testing a headphone amplifier in socket U5 in conjunction with an EVM in U2/U3/U4
41	TP4	Fault–1: Logic level fault–1 output signal. MSB. Open drain.	N/C	No connect
42	TP3	Fault–0: Logic level fault–0 output signal. LSB. Open drain.	N/C	No connect

3.8 TPA005D14 Class-D EVM Bill of Materials

The components in the bill of materials (Table 3–5) were selected for their common values, availability, and the smallest size available to meet these criteria. See Section 3.9 for a schematic showing all the components.

Table 3–5. TPA005D14 Class-D EVM Bill of Materials

Reference	Description	Size	EVM Qty.	Manufacturer/ Part Number
C2, C3, C20	Capacitor, Ceramic Chip, 0.1 μ F, \pm 10%, 50 V, X7R	0805	3	Kemet C0805C104K5RAC
C1, C4, C5, C6, C10, C12, C13, C18, C19, C30, C31	Capacitor, Ceramic Chip, 1 μ F, \pm 10%, 16 V, X7R	1206	11	TDK C3216X7R1C105K
C21, C17	Capacitor, Ceramic Chip, 47 nF, \pm 10%, 50 V, X7R	0805	2	Kemet C0805V473K5RAC
C7, C8, C9	Capacitor, Ceramic Chip, 470 pF, \pm 5%, 50 V, C0G,	0805	3	Kemet C0805C471J5GAC
C22, C23	Capacitor, Ceramic Chip, 5.6 pF, \pm 5%, 50 V, C0G	0603	2	Kemet C0603C569J5GAC
C11, C14	Capacitor, Ceramic Chip, 10 μ F, +80%–20%, 25 V, Y5V	1210	2	muRata GRM235Y5V106Z25
C15, C16	These pads are provided for increase of bulk capacitance as required to meet voltage ripple and temperature operating range specifications.	0.0236" \times 0.138"		
C24, C25	Capacitor, Aluminum Electrolytic, Radial Lead, 33 μ F, \pm 20%, 35 V, FC Series, 80 m Ω @ 100 kHz, 175 mA ripple, –55 to +105°C	0.197" \times 0.0197" \times 0.078"	2	Panasonic EEUFC1V330
C26, C27, C28, C29	Capacitor, Ceramic Chip, 0.22 μ F, \pm 10%, 16 V, X7R	1206	4	Kemet C1206C224K4RAC
L1, L2, L3, L4	Inductor, SMT, 15 μ H, \pm 20%, 2.2 ADC, 47.2 m Ω @ 1 kHz, –20 to +90°C	0.398" \times 0.398" \times 0.220"	4	TDK SLF10145–150
L1, L2, L3, L4 Alternate Value	Inductor, SMT, 15 μ H, \pm 20%, 1.1 ADC, 75 m Ω @ 1 kHz, –20 to +85°C	0.276" \times 0.276" \times 0.126"	4	TDK SLF7032–150
R1, R2, R3, R4, R5, R6, R7, R10	Resistor, Thick Film Chip, SMD, 100 k Ω , \pm 5%, 1/16 W, 150 V, –50 to 150°C, \pm 200 ppm/°C	0603	8	Vishay/Dale CRCW0603104J
R8, R9	Resistor, Thick Film Chip, SMD, 1 k Ω , \pm 5%, 1/16 W, 150 V, –50 to 150°C, \pm 200 ppm/°C	0603	2	Vishay/Dale CRCW0603102J
	Headers, 0.100 in. centers, 1/2 in length	0.5", 0.25", 0.1"	19	Samtec TSW–19–8–G–S
TP1 – TP12	Test Point, Red		12	Farnell 240–345
TP13, TP14	Test Point, Black		2	Farnell 240–333
S1, S2	Switch, Momentary, Push Button, 12 VDC, 50 mA	0.291" \times 0.138" \times 0.134"	2	Panasonic EVQ-PJS04K
J1	Mini Phone Jack, PCB Mount, 3.5 mm, N/C, Stereo	0.512" \times 0.472"	1	Mouser 161–3504
U1	IC, Audio amplifier, class-D, 2 W, 48 pin, DCA pkg	TSSOP48	1	TI TPA005D14DCA

3.9 TPA005D14 Class-D EVM Schematic

The following schematic depicts the TPA005D14 class-D EVM.

Note:

C15, C16, C22, and C23 are optional and have been provided to allow flexibility of design. C22 and C23 are only required when the headphone amplifier gain is set greater than 10 V/V.

Figure 3–22. TPA005D14 Class-D EVM Schematic Diagram

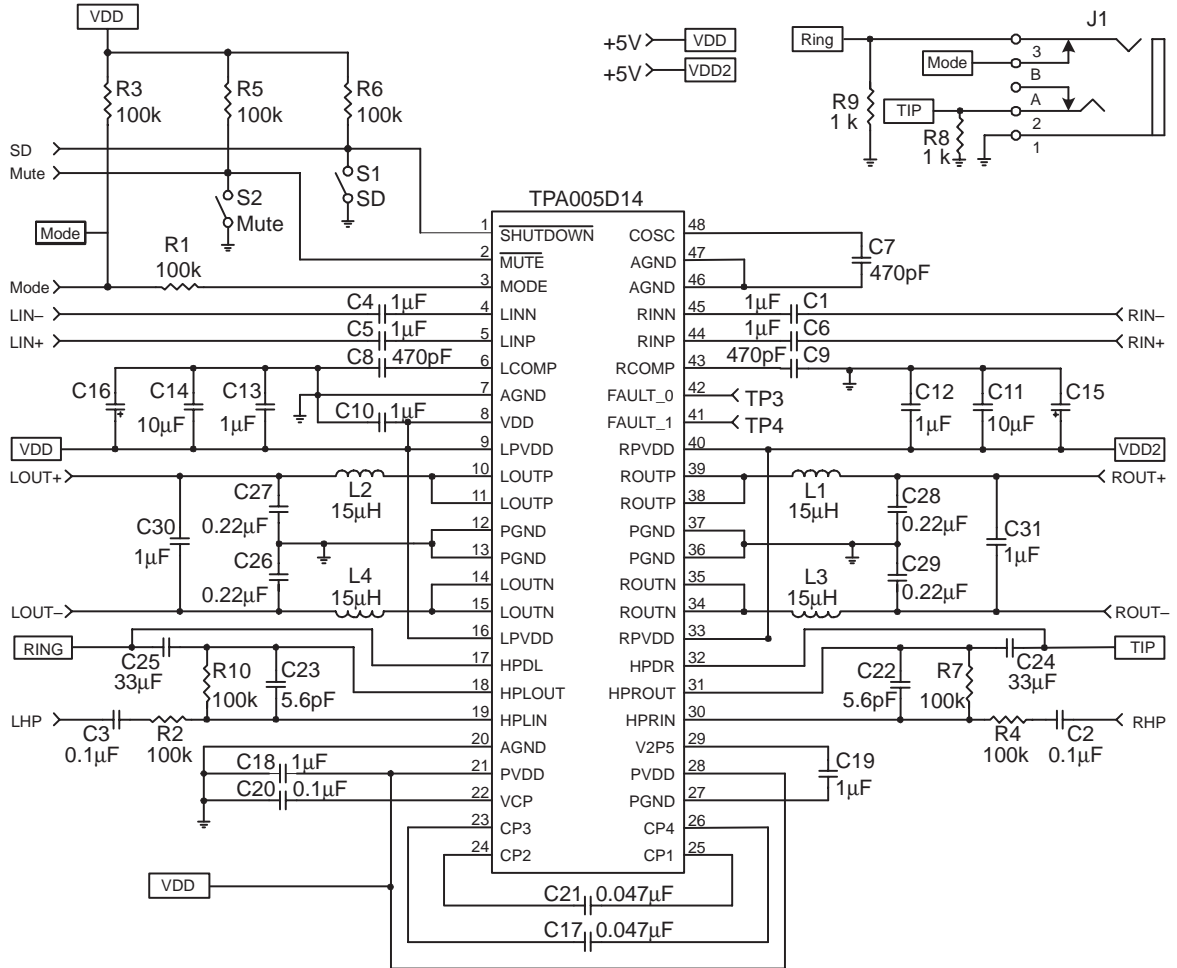

3.10 TPA005D14 Class-D EVM PCB Layers

The following illustrations depict the TPA005D14 class-D EVM PCB assembly and layers. These drawings are not to scale. Gerber plots can be obtained from any TI Sales Office.

Figure 3–23. TPA005D14 Class-D EVM Top Assembly

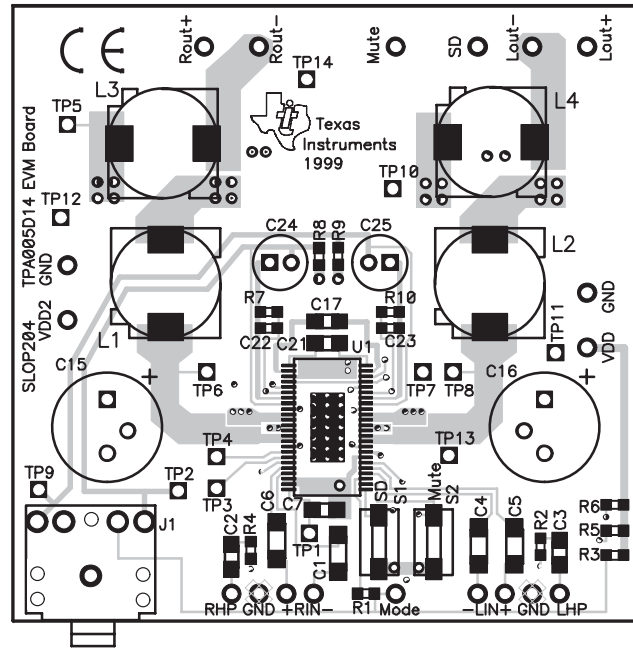

Figure 3–24. TPA005D14 Class-D EVM Bottom Assembly

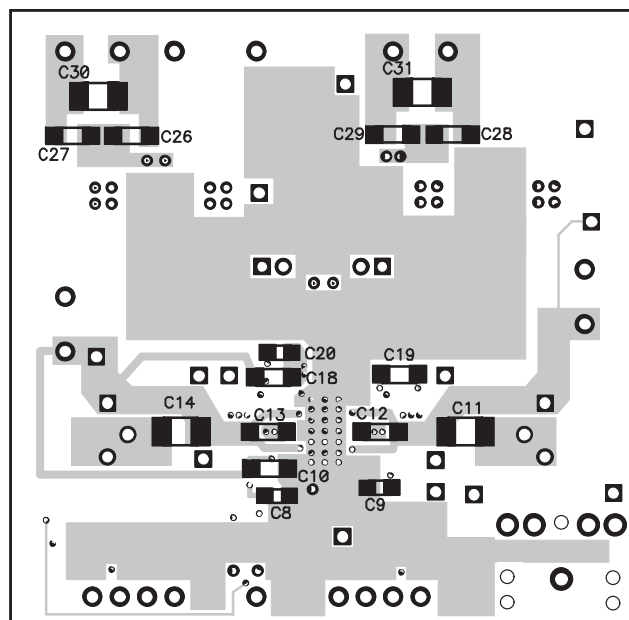

Figure 3–25. TPA005D14 Class-D EVM Top Layer

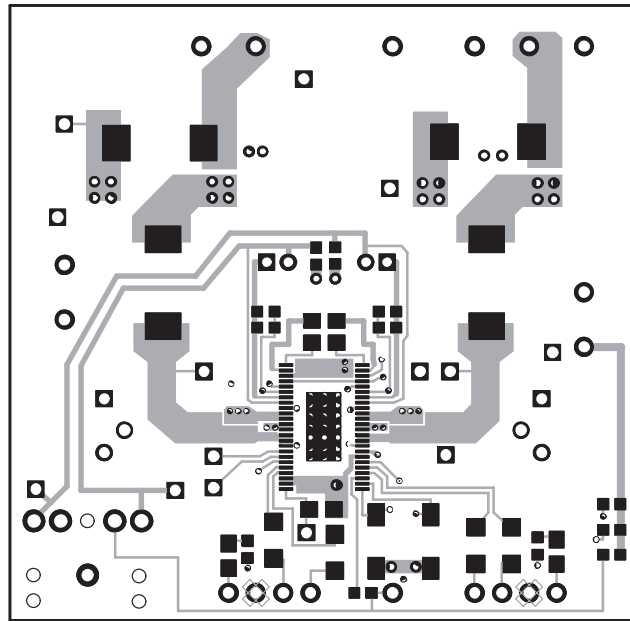

Figure 3–26. TPA005D14 Class-D EVM Second Layer

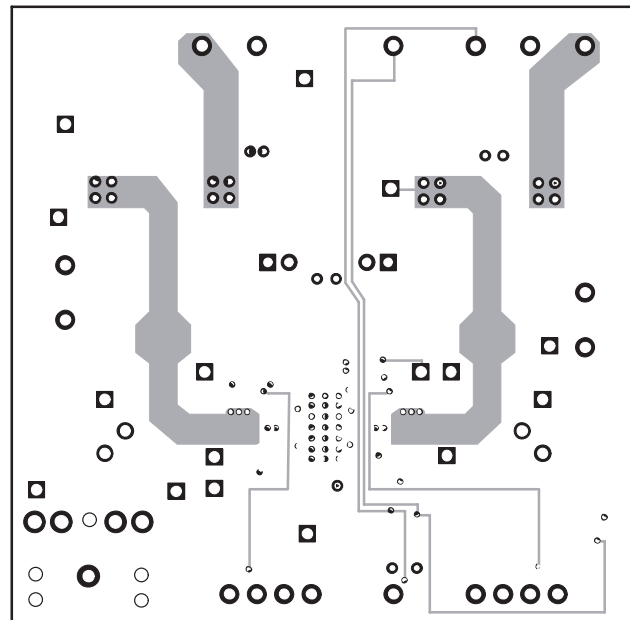

Figure 3–27. TPA005D14 Class-D EVM Third Layer

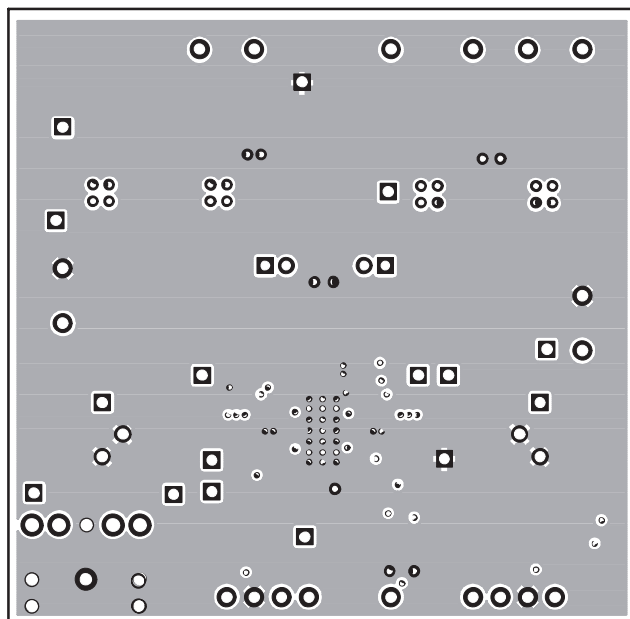

Figure 3–28. TPA005D14 Class-D EVM Bottom Layer

