

UNIQUE[®]

APPLIANCES

== *Classic* ==
by UNIQUE

CLASSIC RETRO 28 BOTTLE WINE COOLER

MODEL NUMBERS: UGP-125CR WF W, UGP-125CR WF B,
UGP-125CR WF T, UGP-125CR WF LG, UGP-125CR WF RB



Intertek
5013515

OWNER'S GUIDE

serial number:

JUN21V1

TABLE OF CONTENTS

03	Important safety notes	12	Parts list
04	Grounding instructions	13	Warranty
05	Installation instructions	14	Appliance information
06	Product features	14	Notes
07	Operation	14	Product registration
07	Wine storage	14	Contact us
08	Care and maintenance		
09	Energy saving tips		
09	Troubleshooting		
10	Electrical diagram		
11	Parts diagram		

WELCOME

Congratulations on your new purchase! We are proud of our quality products and we believe in the dependable service we provide.

Before using the appliance, read through this manual carefully including all the information on safety, installation, operation, and cleaning. These guidelines do not cover every possible condition or situation that may occur. Be safe using common sense and caution when installing, operating and cleaning this appliance. If you are unsure about any of these instructions or warnings, contact your local product dealer or Unique Appliances for assistance.

NEED HELP?

Before you call for service, here are a few things you can do to help us serve you better.

Read this owner's manual: It contains instructions to help you use and maintain your appliance properly.

Visit our website: Our website www.UniqueAppliances.com will give you access to self service tools, FAQs and much more.

If you receive a damaged appliance: Immediately contact the retailer that sold you the appliance.

Save time and money: Check the troubleshooting section at the end of this manual before calling. This section will help you solve common problems that may occur.

IMPORTANT SAFETY NOTES

These warnings are provided in the interest of your safety. Please ensure that you understand them all before installing or using this cooler. Your safety is of paramount importance. If you are unsure about any of these meanings or warnings, contact your local product dealer or Unique Appliances for assistance.

IMPORTANT: After transit where the cooler has been on its side or back, ensure that the cooler is in a level, upright position for 12 hours to allow compressor fluids to redistribute evenly before use.

PRIOR TO INSTALLATION

At delivery, please check that the cooler is complete and has not been damaged during transport. It is not advised to connect an appliance that has been damaged, especially damage to the electrical supply cable or refrigerant circuit. In the event of damage please contact your local product dealer or Unique Appliances for assistance.

DANGER

- Risk of fire or explosion. Flammable refrigerant used. Do not puncture refrigerant tubing.
- Ensure that servicing is done by factory authorized service personnel, to minimize product damage or safety issues.

WARNING

- **WARNING:** When positioning the appliance, ensure the supply cord is not trapped or damaged.
 - **WARNING:** Do not locate multiple portable socket-outlets or portable power supplies at the rear of the appliance.
 - **WARNING:** When disposing of the appliance do so only at an authorized waste disposal centre. Do not expose to flame.
 - **WARNING:** Keep ventilation openings, in the appliance enclosure or in the built-in structure, clear of obstruction.
 - **WARNING:** Risk of child entrapment. Before you throw away your old refrigerator or freezer:
 - Take off the doors.
 - Leave the shelves in place so that children may not easily climb inside.
- This appliance is intended to be used exclusively for the storage of wine.
- The appliance is not suitable for the storage of food.
 - This refrigerating appliance is not suitable for freezing foodstuffs.

This appliance is not intended for use by persons (including children) with reduced physical, sensory or mental capabilities, or lack of experience and knowledge, unless they have been given supervision or instruction concerning use of the appliance by a person responsible for their safety. Children should be supervised to ensure that they do not play with the appliance.

CAUTION

- Risk of fire or explosion. Flammable refrigerant used.
- Consult repair manual or owner's guide before attempting to service this product. All safety precautions must be followed. Service the cooler only if you are a trained or authorized refrigeration technician.
- Dispose of properly in accordance with federal or local regulations.
- Follow handling instructions carefully.

IMPORTANT

- To allow the interior to cool down properly, run the cooler for at least 4 hours empty before adding food.
- This cooler is designed for domestic use only! It is intended for the storage of wine. It is not in-

IMPORTANT SAFETY NOTES

tended for commercial or industrial use.

- Never use excessive force on the handle to open the door.
- If the room/ambient temperature approaches the coolers operating temperature, the cooler may not function correctly. If the room/ambient temperature exceeds 100°F (38°C) the cooler may not function correctly.

CHILD SAFETY: Do not allow children to play in, on or around the cooler. It is not a toy. **THERE IS A DANGER OF SUFFOCATION IF A CHILD BECOMES TRAPPED INSIDE.** When the appliance is not in use, secure or remove the doors to prevent children from playing inside the cabinets.

DANGER

- Risk of child entrapment. Before throwing away an old appliance:
- Remove the door or lid.
- Leave shelves in place so that children may not easily climb inside.
- Cleaning and use maintenance shall not be made by children without supervision.

DANGER OF SUFFOCATION: Keep children away from all packaging material.

DISPOSING OF THE APPLIANCE

When disposing of your cooler, use an authorized disposal site. The refrigerant must be completely drained and collected by an authorized technician for recycling prior to disposal. Check with your local Environmental Agency for recommendations on recycling this appliance in your area. Before disposal remove the electrical connection wiring and also ensure that the doors are removed to pre-vent children from being trapped inside - **DANGER OF SUFFOCATION!**

This marking indicates that this product should not be disposed with other household wastes throughout North America. To prevent possible harm to the environment or human health from uncontrolled waste disposal, recycle it responsibly to promote the sustainable reuse of material resources.



The refrigerant isobutane (R600a) is contained within the refrigerant circuit of the appliance, a natural gas with a high level of environmental compatibility, which is nevertheless flammable. During transportation and installation of the appliance, ensure that none of the components of the refrigerant circuit becomes damaged. The refrigerant (R600a) is flammable. **Warning:** Risk of fire / flammable materials.



GROUNDING INSTRUCTIONS

This appliance must be grounded. Grounding reduces the risk of electrical shock by providing an escape wire for the electrical current.

This appliance has a cord that has a grounding wire with a 3-prong plug. The power cord must be plugged into an outlet that is properly grounded. If the outlet is a 2-prong wall outlet, it must be replaced with a properly grounded 3-prong wall outlet. The serial rating plate indicates the voltage and frequency the appliance is designed for.

WARNING - Improper use of the grounding plug can result in a risk of electric shock. Consult a qualified electrician or service agent if the grounding instructions are not completely understood, or if doubt exists as to whether the appliance is properly grounded. Do not connect your appliance to extension cords or together with another appliance in the same wall outlet. Do not splice the power cord. Do not under any circumstances cut or remove the third ground prong from the power cord. Do not use extension cords or ungrounded (two prongs) adapters. If the power supply cord is damaged, it must be replaced by the manufacturer, its service agent or similar qualified person in order to avoid hazard.

INSTALLATION INSTRUCTIONS

IMPORTANT: After transit where the cooler has been on its side or back, ensure that the cooler is in a level, upright position for 12 hours before connecting the appliance to a power source, this will reduce the possibility of a malfunction in the cooling system from handling during transportation..

UNPACKING AND CLEANING

Remove all packaging and securing tapes from the appliance. To avoid injury and causing damage to the appliance, be extremely cautious when using sharp or pointed tools to complete this task. Keep children away from the packaging material - **DANGER OF SUFFOCATION!** Wash the inside and outside of the appliance with luke warm water and a mild soap or detergent. Abrasive or corrosive cleaning agents, steel wool, scouring sponges, or chemical cleaning agents should not be used under any circumstances. A sponge, soft brush or towel is recommended. After cleaning, thoroughly rinse and dry. You may want to leave the doors open allowing the compartments to ventilate for 20-30 minutes to get rid of residual odors. Check with your local Environmental Agency for recommendations on recycling packaging materials in your area.

POSITIONING THE APPLIANCE

The area in which the cooler is to be installed must be relatively cool, dry, and suitably ventilated. The area must be protected against any inclement weather (rain, snow) and excessive surface dust. To ensure proper function, the appliance must be placed on a flat, firm, and stable surface resting level on all four supports. The floor must be strong enough to support a fully loaded cabinet. Use wood or metal shims to level the cooler if necessary. Do not place the appliance in direct sunlight or near sources of heat, such as a stove or heater, as this can increase electrical consumption and decrease performance. Extreme cold ambient temperatures may also cause the appliance to perform improperly.

This appliance uses the exterior walls to transfer heat from the inside of the cabinet. Ensure that there is adequate space between the cooler and neighboring walls or large objects. **A minimum spacing of 3 inches (7.6 cm) is highly recommended.** This will provide sufficient airflow around the appliance resulting in more efficient operation and longer appliance lifetime. Always keep the air vent openings of the compressor housing cover free from dust and obstructions.

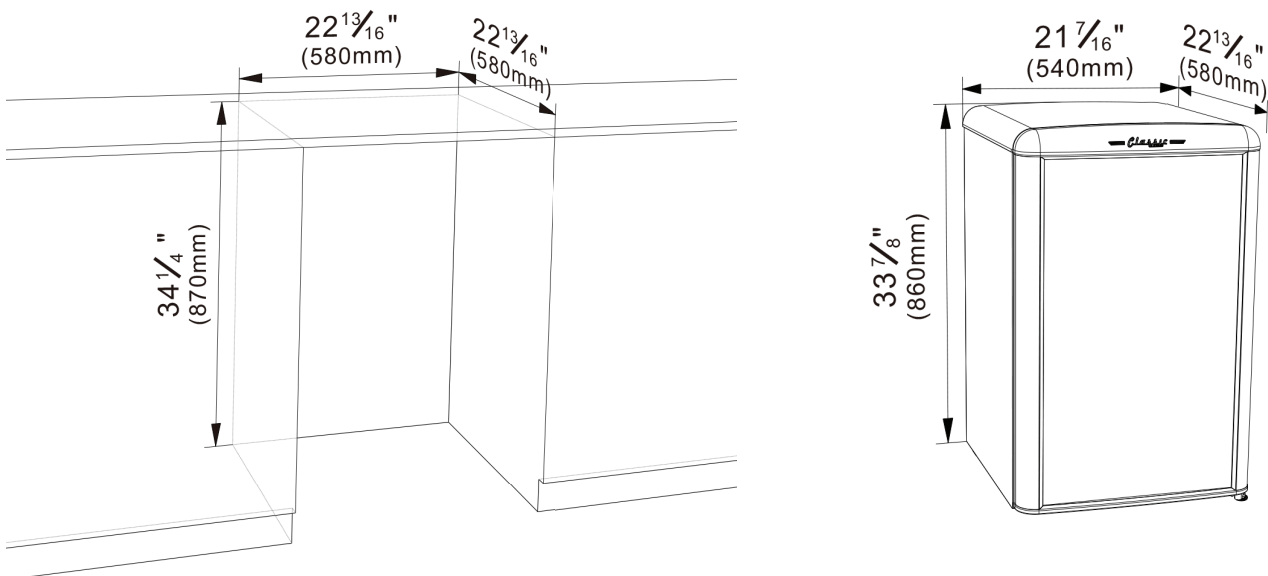

INSTALLATION INSTRUCTIONS

INSTALLATION

- This appliance is heavy. Care should be taken when moving it.
- Be sure that the appliance does not stand on the electrical supply cable. Also, be sure the electrical cable is not squeezed or bent when the appliance is being installed or moved.
- Do not install the appliance near water, for example in a wet basement or near a sink.
- Installation work and adjustments on the appliance must be carried out by qualified personnel only. Work performed by persons with inadequate technical knowledge may adversely effect the performance of the appliance, causing damage to the equipment, and void the warranty.
- It is dangerous to make alterations or attempt to modify this product in any way. Product alterations will void the warranty.

USE

- This appliance is intended for household use only. It is not designed for outside installation, including anywhere that is not temperature controlled (garages, porches, vehicles, etc.).
- Do not store any containers with flammable vapors or liquids in or around the appliance, such as organic solvents, spray cans, gas cans, etc. Danger of explosion!

CLEANING

- Before cleaning your appliance always disconnect it from the electrical power supply.
- Allow inside of cooler to fully thaw, then wash the inside and outside of the appliance with luke warm water and a mild soap or detergent. Abrasive or corrosive cleaning agents, steel wool, scouring sponges, or chemical cleaning agents should not be used under any circumstances.

SERVICING

- This product should be serviced by an authorized technician and only genuine spare parts should be used.
- Under no circumstances should you attempt to repair the appliance yourself unless advised by Unique. Repairs carried out by inexperienced persons may cause injury or serious malfunctioning of the appliance. Un-authorized work may void the warranty.

PRODUCT FEATURES

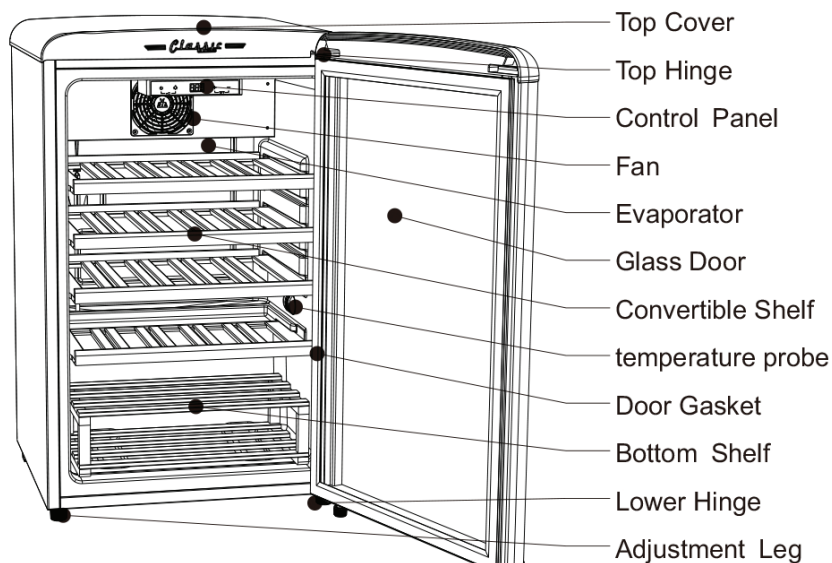

OPERATION

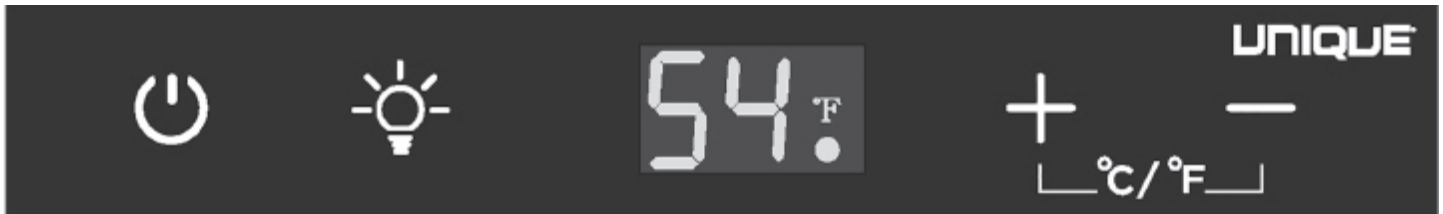

POWER ON/OFF:

1. Press this key for 5 sec, to turn the cooler off, the display screen will indicate “oF” for 60 sec.
2. To turn the cooler back on, touch any key to light the display screen and then press the power key for 5 sec, the cooler will restore its normal operation and work under real-time conditions.

LIGHT ON/OFF BUTTON

Tap the light control button to enable or disable the light.

Note: Leaving the light on for extended periods may increase the temperature inside the cooler

TEMPERATURE “+” “-” BUTTONS:

The display screen will indicate the current set temperature. To adjust the temperature tap the + or - buttons to reach your desired temperature.

Temperature range: 4°C to 20°C (39°F to 68°F)

CELSIUS/FAHRENHEIT SELECTION:

Tap both keys at the same time, and then you can switch over between Celsius and Fahrenheit. Each time the key is tapped, a switchover will be made. When setting the system temperature, you can not switch over between Celsius and Fahrenheit.

NORMAL OPERATING SOUNDS

You may hear faint gurgling or bubbling sounds when the refrigerator is being pumped through the refrigerant coils.

When the compressor is on, the refrigerant is being pumped through the appliance and you will hear a whirring or pulsing sound from the compressor.

A thermostat controls the compressor and you may hear a “click” when the thermostat cuts in and out. This product uses a fan to distribute the air inside the appliance which produces a slight hum.

WINE STORAGE

The maximum capacity of is 28 - 750 ml wine bottles, when stocked as per these instructions:

1. Position 5 bottles on the first shelf and 2 on either side of the control panel as per Fig. A.
2. Position 5 bottles across on shelves 2, 3 and 4, as per Fig. B.
3. Position 3 bottles staggered on the bottom 2 tiered shelves, as per Fig. C.

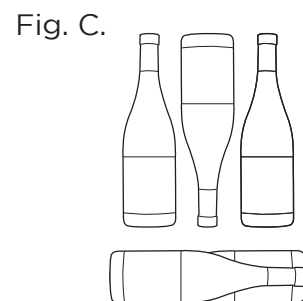
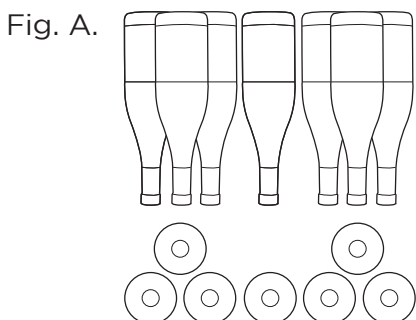

CARE AND MAINTENANCE

INTERNAL CLEANING

Wash the inside of the appliance with luke warm water and a mild soap. Never use abrasive or corrosive cleaning agents, steel wool, scouring sponges, chemical cleaning agents, or highly perfumed cleaning products to clean the interior as these will damage the surface and leave behind a strong odor. A sponge, towel, or soft brush is recommended. Wash with a mixture of two tablespoons (30ml) of baking soda to 1 quart (1.14L) warm water. After cleaning, wipe all surfaces with a soft cloth and clean water to rinse, and allow the cooler to dry.

EXTERNAL CLEANING

Wash the outside of the cabinet with warm water and a mild soap or detergent. Do not use abrasive or corrosive cleaning agents, chemical cleaning agents, steel wool or scouring sponges to clean the cooler as it may cause damage to the surfaces.

POWER FAILURE

Most power failures are corrected within a few hours and should not affect the internal temperature of the appliance if the number of times the door is opened is kept to a minimum. If the power is going to be off for a longer period of time, take the proper steps to protect the contents.

Note: Wait 3 to 5 minutes before attempting to restart the refrigerator if operation has been interrupted.

VACATION

- Short vacations: Leave the appliance operating during vacations of less than three weeks.
- Long vacations: If the appliance will not be used for several months, remove all items and disconnect the appliance from its power source. Clean and dry the interior thoroughly. To prevent odor and mold growth, leave the door open slightly, blocking it open if necessary.

MOVING

- Remove all items.
- Tape down shelves inside the appliance.
- Turn the adjustable leg up to the base to avoid damage.
- Tape the door shut.
- Be sure the appliance stays in the upright position during transportation. Protect the outside of the appliance with a blanket.
- If the appliance is placed on its back or side during transportation, upon reaching the destination, allow it to remain upright for 12 hours before plugging in to avoid damage to internal components.

CUSTOMER RESPONSIBILITIES

The following items are the responsibility of the customer and are not covered by the warranty:

- Proper care and use of the appliance as described in this manual.
- Damage to the interior or exterior finish or components after delivery.
- Proper power supply, circuit breaker, wiring, and connections.
- Service required as a result of alteration, misuse, abuse, flooding, fire, lightning, or other acts of God.

ENERGY SAVING TIPS

- Do not install the cooler close to sources of heat, such as a stove, boiler, heater, chimney, etc, and avoid exposure of the appliance to direct sunlight.
- Locate the appliance in a cool well-ventilated room and make sure that the air vents of the compressor housing cover are not obstructed. Also allow adequate spacing around the cabinet for air circulation (3” or 7.5cm)
- Avoid keeping the door open for extended periods of time or opening the door too frequently as warm air will enter the cabinet and cause the compressor to run unnecessarily often.
- Ensure there are no obstructions preventing the doors from closing properly and forming a tight seal.

TROUBLESHOOTING

PROBLEM	SOLUTION
Appliance is connected but no power	<ul style="list-style-type: none"> • Check your circuit breaker as it might have tripped • Plug not fully inserted into the wall outlet • Is the power button on
Appliance is operating, but the interior (cabinet) is not cold	<ul style="list-style-type: none"> • Allow the appliance at least 4 hrs to cool down once turned on. • Check that the thermostat control knob is turned to the correct setting relevant to the room/ambient temperatures. • Check that the room/ambient temperature is not approaching the internal operating temperature and does not exceed to 100°F (38°C). • Does the cabinet have adequate ventilation around the side walls, allowing it to transfer heat properly? (See Installation section)
Appliance runs continuously	<ul style="list-style-type: none"> • Temperature setting is too cold • Door not shut properly or opened excessively • Recently added a large quantity of warm wine to the cabinet • Close proximity to heat source or direct sunlight • Ambient temperature or humidity is very high
The door will not open	<ul style="list-style-type: none"> • Has the door just been opened? If so, leave the appliance closed for a few minutes to allow the air pressure to equalize and try again.
Condensation on the cabinet, doors or floor	<ul style="list-style-type: none"> • Is the weather hot and humid? If so, this will increase the rate of frost build-up in the cabinet. • Ensure that wine is properly stored • Check that the door is closed and has a good seal, and that nothing is preventing the door from closing properly. • Large quantities of wine have recently been placed in the cooler, and/or the door is frequently opened. • Ensure that proper care and maintenance of the appliance has been performed (cleaning, defrosting, etc...) • The condensation will subside once ambient humidity conditions return to normal. • Ensure that the door is fully closed and that the gasket is sealing against the cabinet. Open the door only as needed and for short periods of time
Noise	<ul style="list-style-type: none"> • Refer to “Normal Operating Sounds” (page 7)
Light does not work	<ul style="list-style-type: none"> • Do you have power • Contact Unique’s technical service department for instructions on how to fix the issue.
There is any odor in the cooler	<ul style="list-style-type: none"> • The new cooler may give off the smell of the foaming agent or plastic. That’s normal, and such smell will disappear slowly in future.

ELECTRICAL DIAGRAM

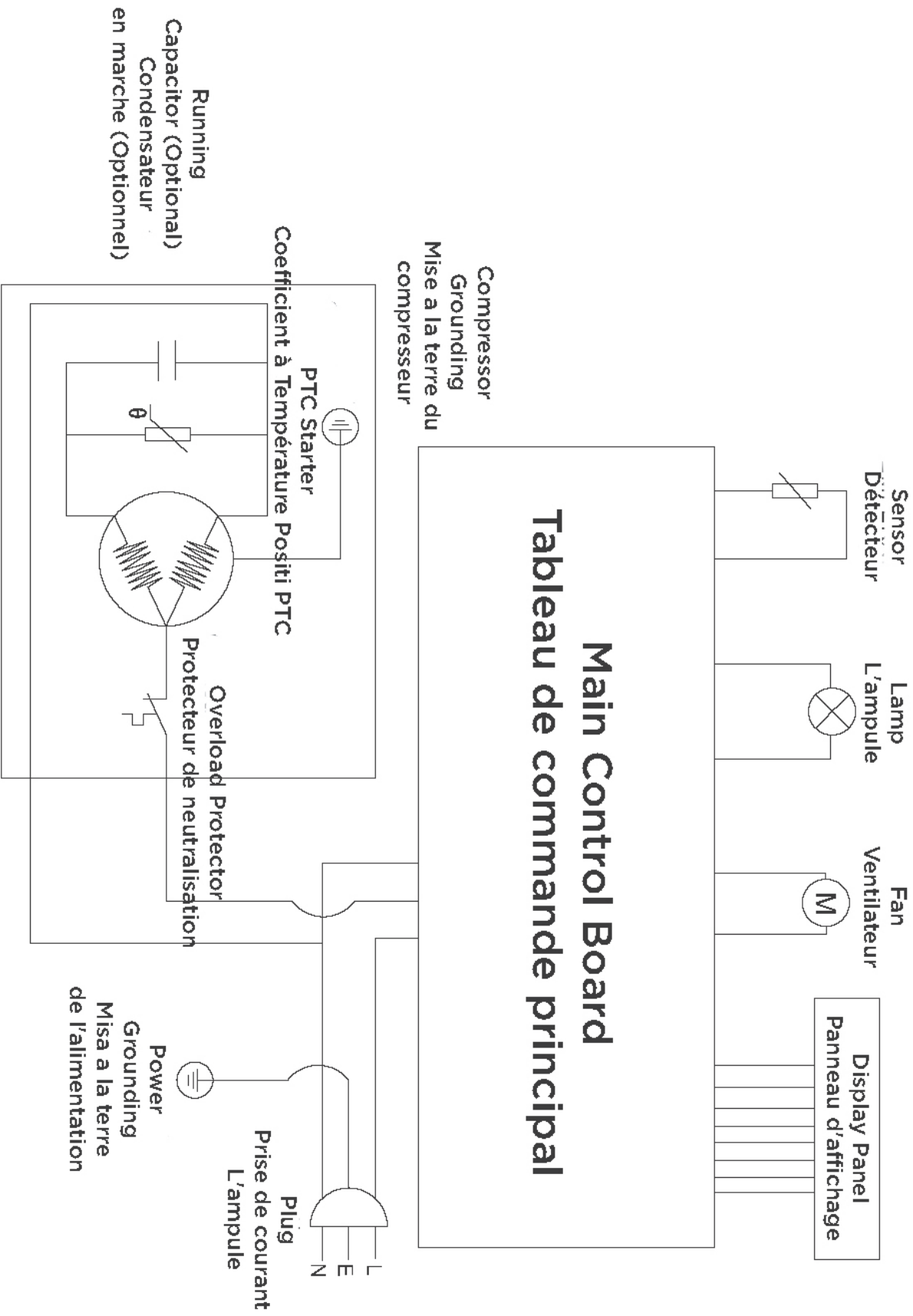

PARTS DIAGRAM

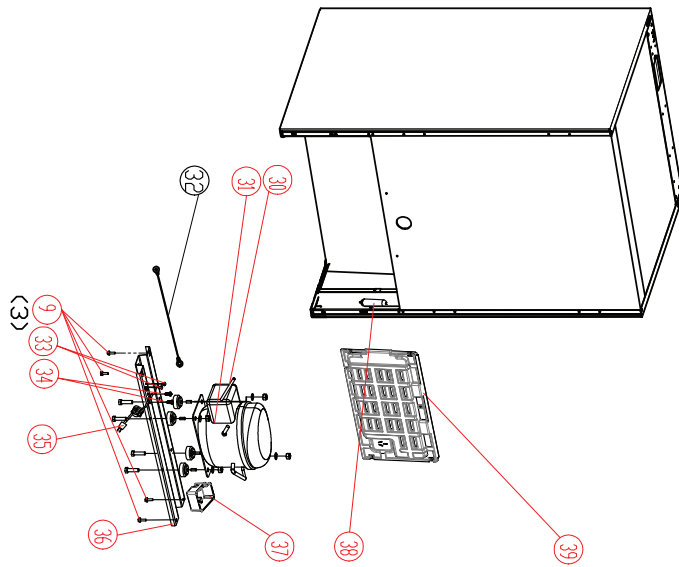
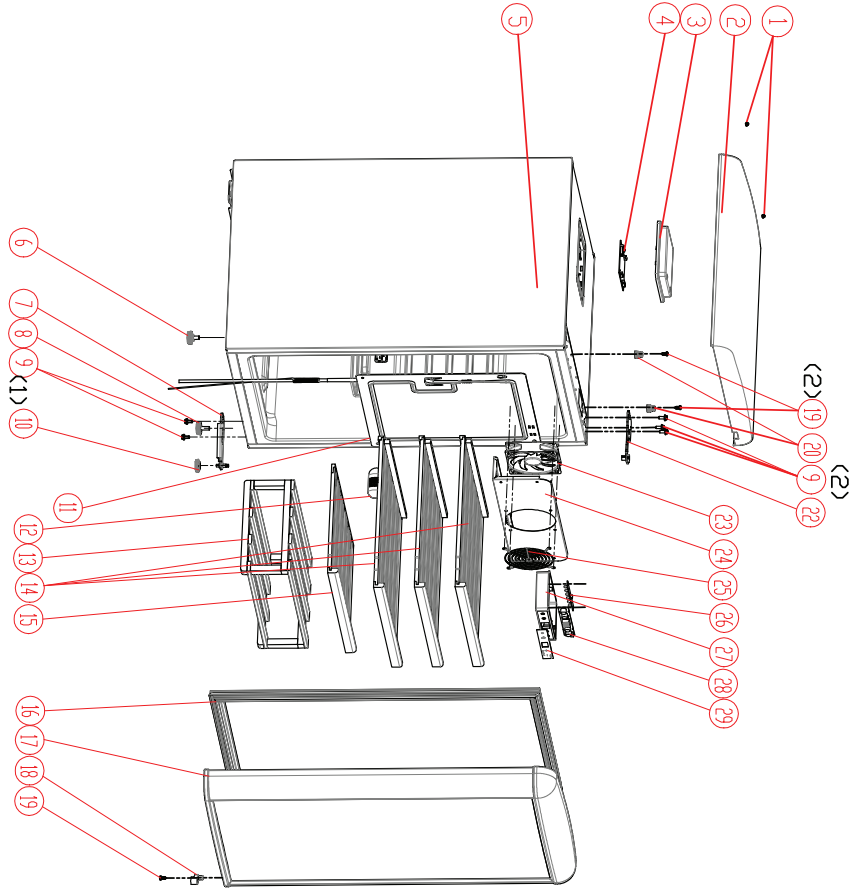

Please visit our website www.uniqueappliances.com to view a PDF version of the schematics which will allow you to zoom in & out

PARTS LIST

NO.	QTY	PART NUMBER	DESCRIPTION
1	2		
2	1	UGP-BCD125-01W	UGP-125L Top Cover White
		UGP-BCD125-01B	UGP-125L Top Cover Black
		UGP-BCD125-01T	UGP-125L Top Cover Torquoise
		UGP-BCD125-01LG	UGP-125L Top Cover Light Green
3	1	UGP-BCD125-04	UGP-125L PCB Cover Panel
4	1	UGP-BCDW-J06-01	UGP-125L PCB
5	1		
6	1	UGP-BCD125-T00-10A	UGP-125 Adjustable Foot (Left Side)
7	1	UGP-BCD125-02-00	UGP-125L Bottom Hinge ASSY
8	1	UGP-BCD125-T00-10	UGP-125 Adjustable Foot (Right Side)
9	9		
10	1	UGP-BCD-T00-11	UGP-125L Adjustable Foot (Hinge Mount)
11	1	UGP-BCD125J-00-01	UGP-125L Evaporator
12	1	UGP-BCD125KSM-00-14	UGP-125L Temperature Sensor Cover
13	1	UGP-BCD125-T00-17G	UGP-125L Bottom Bottle Rack
14	3	UGP-BCD125-T00-17E	UGP-125L Upper Bottle Rack (3 per unit)
15	1	UGP-BCD125-T00-17F	UGP-125L Middle Bottle Rack
16	1	UGP-BCD125-06-05	UGP-125L Door Seal
17	1	UGP-BCD125-06-00W	UGP-125L Door White
		UGP-BCD125-06-00B	UGP-125L Door Black
		UGP-BCD125-06-00T	UGP-125L Door Torquoise
		UGP-BCD125-06-00LG	UGP-125L Door Light Green
18	1	UGP-BCD125-T03-01B	UGP-125L Door Stopper
19	3		
20	2	UGP-BCD125-00-02	UGP-125L Top Cover Seat
22	1	UGP-BCD125-0001-00	UGP-125L Top Hinge
23	1	UGP-BCD125-WJ03-04	UGP-125L Air Duct Fan
24	1	UGP-BCD125-11-01	UGP-125L Air Duct Cover
25	1	UGP-BCD125-0005-02	UGP-125L Air Duct Fan Cover
26	1	UGP-BCD125-T04-14A	UGP-125L Interior LED Light
27	1	UGP-BCD125-JSC85-06	UGP-125L Control Board Housing
28	1	UGP-BCD125-WJ06-00	UGP-125L Control Board
29	1	UGP-BCD125-JC12500-07	UGP-125L Display Sticker
30	1		
31	1	UGP-BCD125-UKN35YAT	UGP-125L Compressor UKN35YAT / R600a
32	1	UGP-BCD125-WD00-02B	UGP-125L Compressor Grounding Wire
33	2		
34	2		
35	1	UGP-BCD125-WD01-01M	UGP-125L Power Cord
36	1	UGP-BCD125-BC106SUNA00-15	UGP-125L Compressor Base
37	1	UGP-BCD125-T00-38	UGP-125L Drip Tray
38	1	UGP-BCD125-WZ00-01	UGP-125L Drier Filter
39	1	UGP-BCD125-PC00-01	UGP-125L Plastic Compressor Back Cover

WARRANTY

Unique Gas Products Ltd. (hereafter “Unique”) warrants that this UNIQUE cooler is free from manufacturer’s defects in material and workmanship under normal usage and service under the following terms.



TERMS OF WARRANTY

Plastic parts are warranted for thirty (30) days from the date of purchase, with no extensions provided.

Parts Warranty

This appliance has been designed for domestic household use. If properly installed, adjusted and operated under normal conditions in accordance with printed instructions, it will satisfactorily perform the functions that are generally expected of this type of appliance.

If the appliance fails to do so because of a defect in material or workmanship within **one year** from the original date of purchase: Unique will at our option, repair, exchange, or correct by other means Unique consider appropriate, any part(s) Unique finds to be defective except for the surface finish.

Ownership

This Warranty is made only to the first purchaser (“original purchaser”) who acquires this cooler for his/her own use and will be honored by Unique Gas Products Ltd. and by the Seller. Purchaser must retain their receipt as proof of purchase date.

Warranty Conditions

This warranty does not apply to any appliance that has been subjected to alterations, misuse, abuse (including damage by foreign agents or chemicals), accident, improper installation or service, delivery damage, or other than normal household use and service. This UNIQUE appliance must be serviced regularly as outlined in the Owner’s Manual. Neither Unique Gas Products Ltd. nor the selling dealer will be liable for direct or indirect loss of foods caused by failure in operation. In case of damage, the owner must provide proof of purchase, Model, and Serial Number to the selling dealer or Unique Gas Products Ltd. This warranty is LIMITED STRICTLY to the terms indicated herein, and no other expressed warranties or remedies thereunder shall be binding on Unique.

Purchaser’s Responsibilities

The purchaser will be responsible for the costs of any service calls requested to demonstrate or confirm the proper operation of the appliance, the installation, or to correct malfunctions in the appearance created by the operation of the appliance in a manner not prescribed by or cautioned against in the use and care instructions.

Model and Serial Number

The appliance model number and serial number can be found on a rating plate attached at the back of the cooler. The purchaser should always refer to the model and serial number when talking to or contacting the dealer from whom the appliance was purchased.

EXCLUSIONS

Save as herein provided, by Unique, there are no other warranties, conditions, representations or guarantees, express or implied, made or intended by Unique or its authorized distributors and all other warranties, conditions, representations or guarantees, including any warranties, conditions, representations or guarantees under any Sale of Goods Act or like legislation or statute is hereby expressly excluded. Save as herein provided, Unique shall not be responsible for any damages to persons or property, including the unit itself, howsoever caused or any consequential damages arising from the malfunction of the unit and by the purchase of the unit, the purchaser does hereby agree to indemnify and hold harmless Unique from any claim for damages to persons or property caused by the unit

Removal or disfigurement of the serial plate will void the warranty. The purchaser will be responsible for any expenses involved in making the refrigerator readily accessible for servicing. The purchaser will be responsible for any extra charges where the installation is in a remote location such as un-assumed roads, islands, areas known as cottage country, more than 20 Km outside a Metropolitan area, or where a technician is not available. Freight damage is not covered by this warranty.

GENERAL PROVISIONS

No warranty or insurance herein contained or set out shall apply when damage or repair is caused by any of the following:

- 1) Power failure.
- 2) Damage in transit or when moving the appliance.
- 3) Improper power supply such as low voltage, defective house wiring or inadequate fuses.
- 4) Accident, alteration, abuse or misuse of the appliance such as inadequate air circulation in the room or abnormal operating conditions (ie. extremely high or low room temperature).
- 5) Use for commercial or industrial purposes (ie. If the appliance is not installed in a domestic residence).
- 6) Fire, water damage, theft, war, riot, hostility, acts of God such as hurricanes, floods etc.
- 7) Service calls resulting in customer education.
- 8) Improper Installation (ie. Building-in of a free standing appliance or using an appliance outdoors that is not approved for outdoor application, including but not limited to: garages, patios, porches or anywhere that is not properly insulated or climate controlled). Proof of purchase date will be required for warranty claims; retain bills of sale. In the event that warranty service is required, present the proof of purchase to our authorized service depot.
- 9) Product purchased “as is” are not covered by this warranty.

Nothing within this warranty shall imply that Unique will be responsible or liable for any spoilage or damage to food or other contents of this appliance, whether due to any defect of the appliance, or its use, whether proper or improper

Factory Assistance

If the purchaser is unable to locate an authorized dealer/service agent, or if the purchaser does not receive satisfaction from the dealer, they may contact Unique Appliances Customer Service directly at Toll Free 1-877-427-2266 or 905-827- 6154.

APPLIANCE INFORMATION

APPLIANCE INFORMATION

(manual copy - keep with your records)

To make care and servicing of your cooler easy and efficient, please record the following information for future reference:

Model:

Serial Number:

Purchased From:

Date Purchased:

NOTES

PRODUCT REGISTRATION

Please visit our website at <https://uniqueappliances.com/product-registration/> to register your product.

CONTACT US

For questions related to the operation, safety or the purchase of your cooler, please contact your dealer for more information. For general information, contact our customer service department:



Email

info@UniqueAppliances.com



Toll-free

1-877-427-2266 or 1-905-827-6154
(available during regular business
hours, 8:30 am to 4:30 pm, EST.)



Website

www.uniqueappliances.com



© 2021 Unique Appliances Ltd., 2245 Wycroft Road,
Oakville, Ontario, Canada, L6L 5L7

www.uniqueappliances.com