

MR. HUSSAM SAMIR

# CLASSIFIED ONE

---

## GENERAL PHYSICS

IGCSE

2013 – 2014



MR. HUSSAM SAMIR

PHYSICS

## Examination Questions

1. The diagram shows a thick – walled tube. The thickness of the wall is 3mm.

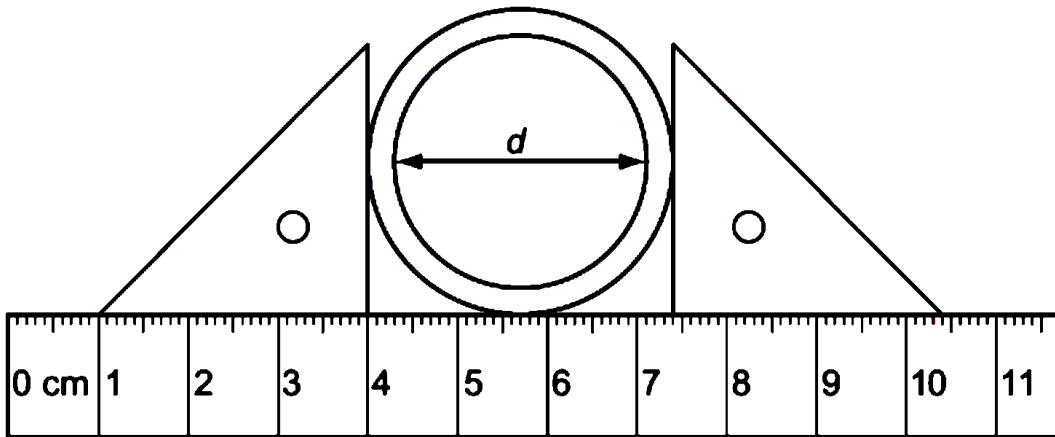

What is the internal diameter  $d$  of the tube?

- A) 2.8 cm      B) 3.1 cm      C) 3.4 cm      D) 7.4 cm

2. The mass of a full bottle of cooking oil is 1.30 kg. When exactly half of the oil has been used, the mass of the bottle plus the remaining oil is 0.90 kg

What is the mass of the empty bottle?

- A) 0.40 kg      B) 0.50 kg      C) 0.65 kg  
D) 0.80 kg

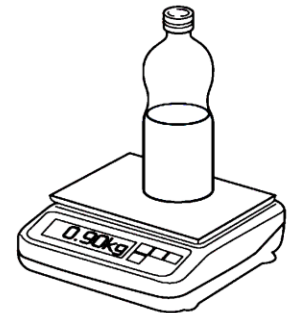

3. A force acts on a moving rubber ball. How many of the following changes could happen to the ball because of the force?

- a change in direction
- a change in shape
- a change in mass
- a change in speed

- A) 1      B) 2      C) 3      D) 4

4. A light aircraft stands at rest on the ground. It stands on three wheels, one at the front and two further back.

Which point could be its centre of mass?

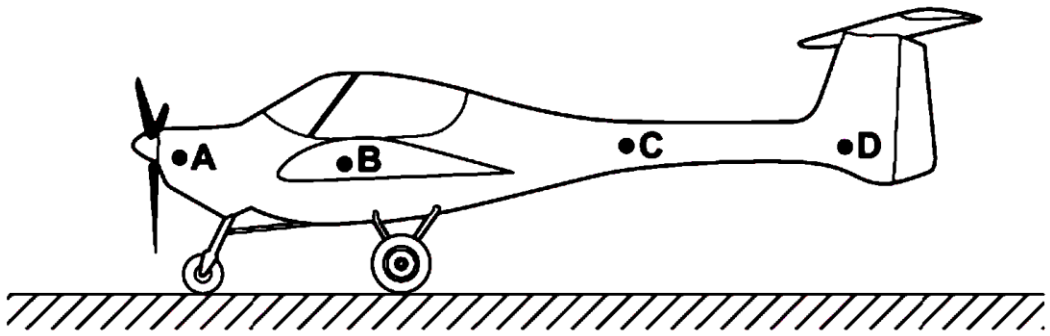

5. Which form of energy is used to generate electrical energy in a tidal power station?
- A chemical energy
  - B gravitational energy
  - C internal energy (thermal energy)
  - D nuclear energy

6. Which line in the table gives an example of the stated form of energy?

	form of energy	example
<b>A</b>	gravitational	the energy due to the movement of a train
<b>B</b>	internal	the energy due to the flow of cathode rays in a cathode ray tube
<b>C</b>	kinetic	the energy due to the position of a swimmer standing on a high diving board
<b>D</b>	strain	the energy due to the compression of springs in a car seat

7. State what is meant by the terms

- (i) *weight*, .....
- (ii) *density*. .....

8. A student is given a spring balance that has a scale in newtons. The student is told that the acceleration of free-fall is  $10 \text{ m/s}^2$ .

- (i) Describe how the student could find the mass of an irregular solid object.  
.....  
.....  
.....
- (ii) Describe how the student could go on to find the density of the object.  
.....  
.....  
.....  
.....

9. Fig. 1.1 shows three forces acting on an object of mass 0.5 kg. All three forces act through the centre of mass of the object.

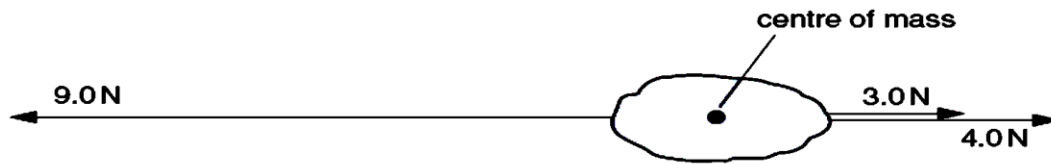
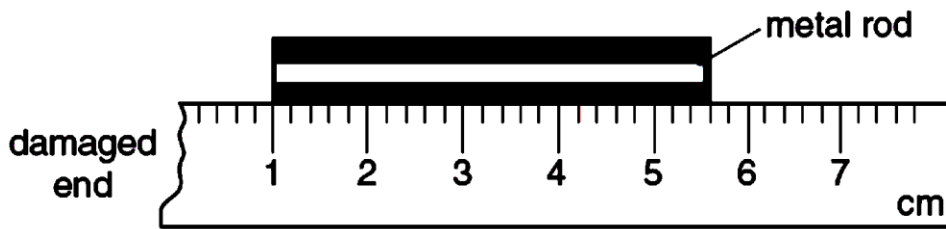

Fig. 1.1

Calculate

- (i) the magnitude and direction of the resultant force on the object,  
 magnitude = ..... direction .....
- (ii) the magnitude of the acceleration of the object.  
 acceleration =.....

10. A girl uses a rule to measure the length of a metal rod. Because the end of the rule is damaged, she places one end of the rod at the 1 cm mark as shown.



How long is the metal rod?

- A) 43 mm
- B) 46 mm
- C) 53 mm
- D) 56 mm

11. Fig. 2.1 shows apparatus for investigating moments of forces.

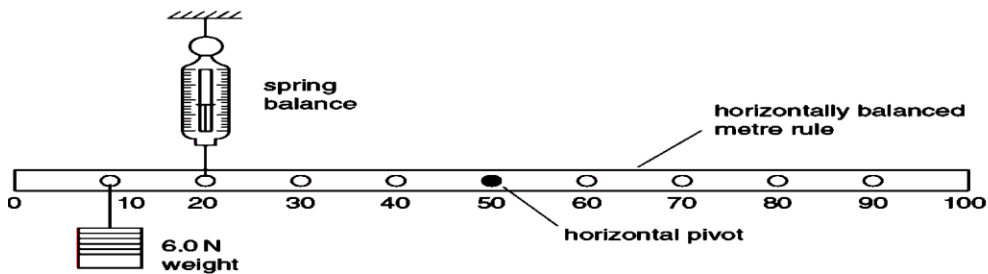

Fig. 2.1

The uniform metre rule shown in Fig. 2.1 is in equilibrium.

- (a) Write down two conditions for the metre rule to be in equilibrium.  
 condition 1 .....

.....  
 .....  
 condition 2 .....  
 .....  
 .....

**(b)** Show that the value of the reading on the spring balance is 8.0N.

**(c)** The weight of the uniform metre rule is 1.5N.  
 Calculate the force exerted by the pivot on the metre rule.  
 magnitude of force = .....  
 direction of force .....

12. A stone falls freely from the top of a cliff into the sea. Air resistance may be ignored. Which graph shows how the acceleration of the stone varies with time as it falls?

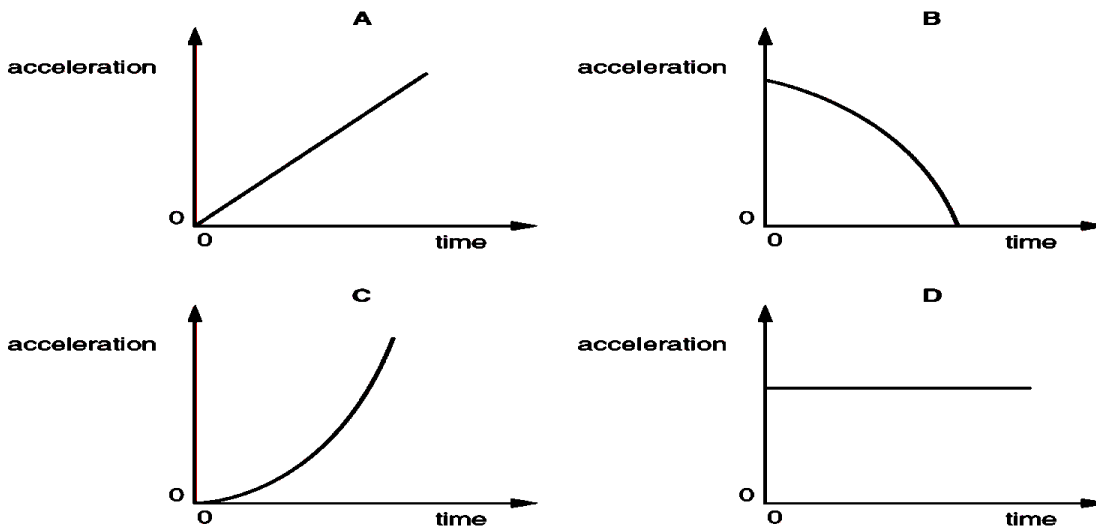

13. The speed of a cyclist reduces uniformly from 2.5 m/s to 1.0 m/s in 12 s.

**(a)** Calculate the deceleration of the cyclist.  
 deceleration = .....

**(b)** Calculate the distance travelled by the cyclist in this time.  
 distance = .....

14. Which of the following statements is correct?

- A Mass and weight are different names for the same thing.
- B The mass of an object is different if the object is taken to the Moon.
- C The weight of a car is one of the forces acting on the car.
- D The weight of a chocolate bar is measured in kilograms.

15. Fig. 3.1 shows the arm of a crane when it is lifting a heavy box.

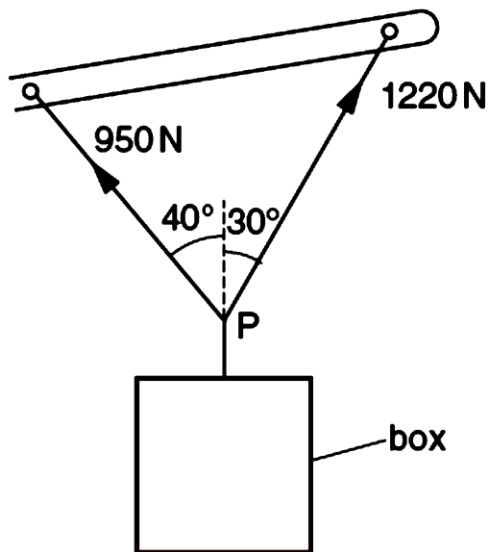

**Fig. 3.1**

By the use of a scale diagram (**not** calculation) of the forces acting at P, find the weight of the box.

16. A child is standing on the platform of a station, watching the trains.



A train travelling at  $30 \text{ m/s}$  takes  $3 \text{ s}$  to pass the child. What is the length of the train?

- A) 10 m
- B) 30 m
- C) 90 m
- D) 270 m

17. In which of these situations is no resultant force needed?

- A a car changing direction
- B a car moving in a straight line at a steady speed
- C a car slowing down
- D a car speeding up

18. A car accelerates along a road as it rises uphill.

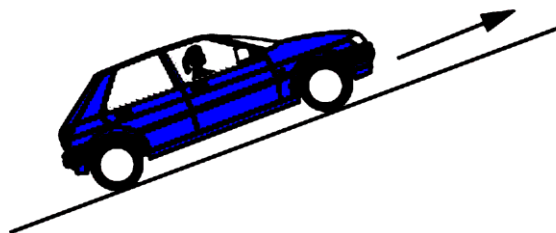

Which energy changes are taking place?

	energy of motion (kinetic energy)	energy of position (gravitational potential energy)
<b>A</b>	decreasing	decreasing
<b>B</b>	decreasing	increasing
<b>C</b>	increasing	decreasing
<b>D</b>	increasing	increasing

19. A group of students attempts to find out how much power each student can generate. The students work in pairs in order to find the time taken for each student to run up a flight of stairs. The stairs used are shown in Fig. 1.1.

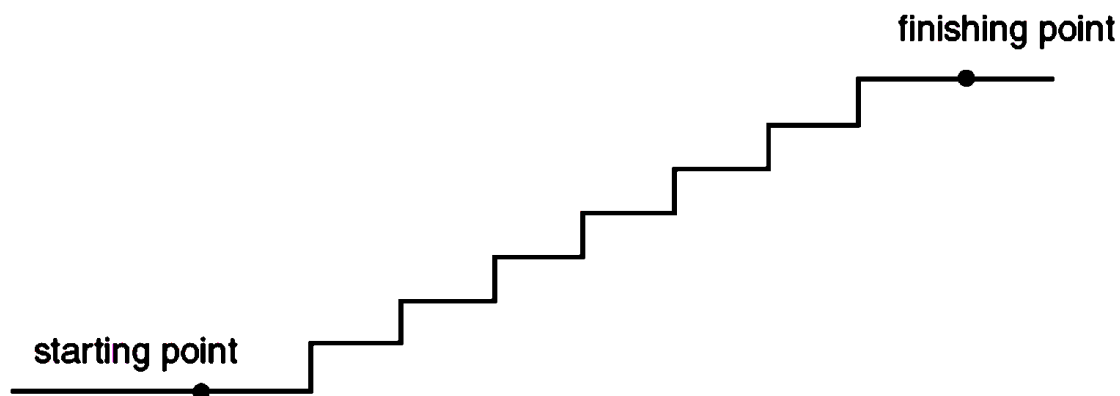

**Fig. 1.1**

- (a) Make a list of all the readings that would be needed. Where possible, indicate how the accuracy of the readings could be improved.
- (b) Using words, not symbols, write down all equations that would be needed to work out the power of a student.
- (c) (i) When the student has reached the finishing point and is standing at the top of the stairs, what form of energy has increased to its maximum?

(ii) Suggest why the total power of the student is greater than the power calculated by this method.

20. A small rubber ball falls vertically, hits the ground and rebounds vertically upwards.

Fig. 2.1 is the speed-time graph for the ball.

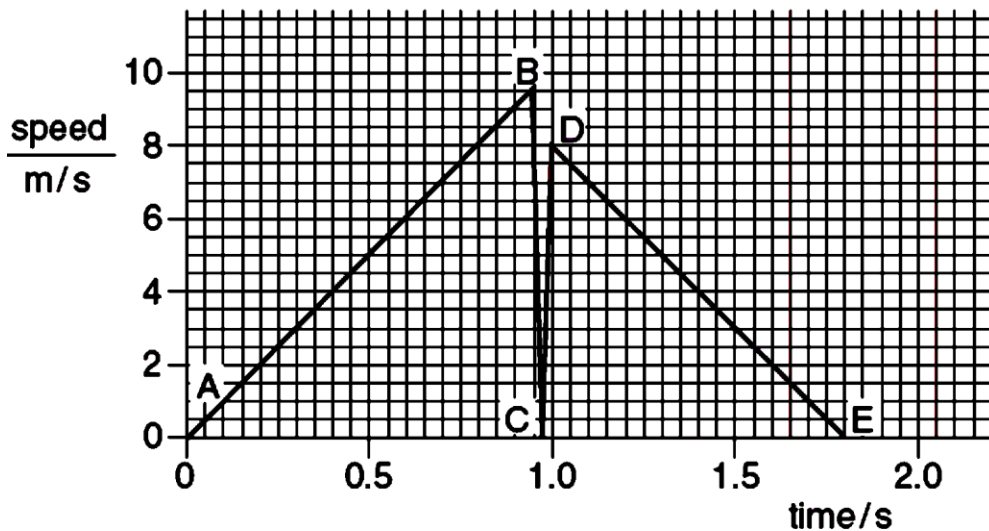

**Fig. 2.1**

(a) Using information from the graph, describe the following parts of the motion of the ball.

(i) part AB

(ii) part DE

(b) Explain what is happening to the ball along the part of the graph from B through C to D.

(c) Whilst the ball is in contact with the ground, what is the

(i) overall change in speed,  
change in speed = .....

(ii) overall change in velocity?  
change in velocity = .....

(d) Use your answer to (c) to explain the difference between speed and velocity.

(e) Use the graph to calculate the distance travelled by the ball between D and E.  
distance travelled = .....



(f) Use the graph to calculate the deceleration of the ball between D and E.

deceleration = .....

21. Fig. 1.1 shows a smooth metal block about to slide down BD, along DE and up EF. BD and DE are friction-free surfaces, but EF is rough. The block stops at F.

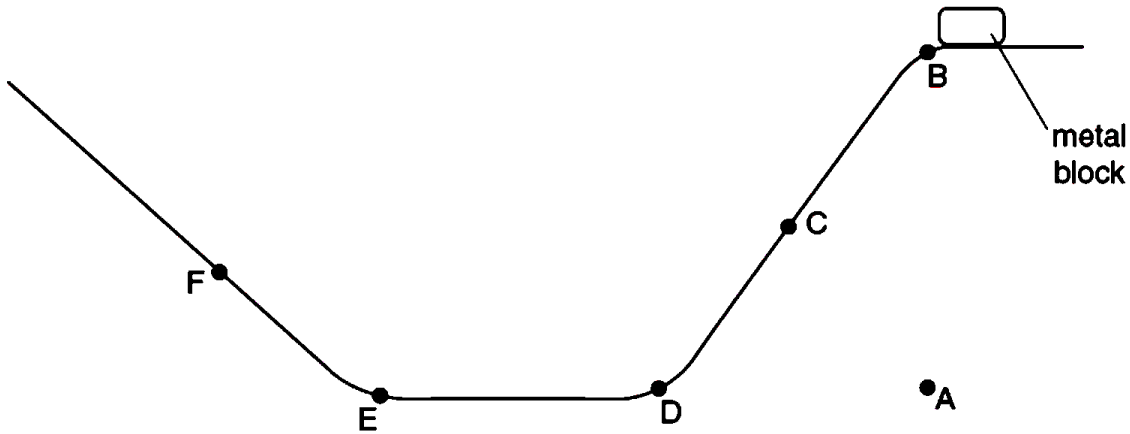

Fig. 1.1

(a) On Fig. 1.2, sketch the speed-time graph for the journey from B to F.

Label D, E and F on your graph.



Fig. 1.2

(b) The mass of the block is 0.2 kg. The vertical height of B above A is 0.6 m. The acceleration due to gravity is  $10 \text{ m/s}^2$ .

(i) Calculate the work done in lifting the block from A to B.

work done = .....

(ii) At C, the block is moving at a speed of 2.5 m/s. Calculate its kinetic energy at C.

C.

kinetic energy = .....

(c) As it passes D, the speed of the block remains almost constant but the velocity changes. Using the terms *vector* and *scalar*, explain this statement.

(d) F is the point where the kinetic energy of the block is zero. In terms of energy changes,

explain why F is lower than B.

22. A student is given the following apparatus in order to find the density of a piece of rock.

100 g mass

metre rule

suitable pivot on which the rule will balance

measuring cylinder that is big enough for the piece of rock to fit inside

cotton

water

The rock has a mass of approximately 90 g.

(a) (i) In the space below, draw a labelled diagram of apparatus from this list set up so that the student is able to find the mass of the piece of rock.

(ii) State the readings the student should take and how these would be used to find the mass of the rock.

(b) Describe how the volume of the rock could be found.

(c) The mass of the rock is 88 g and its volume is  $24 \text{ cm}^3$ .

Calculate the density of the rock.

density of rock = .....

23. Fig. 1.1 shows a cycle track.

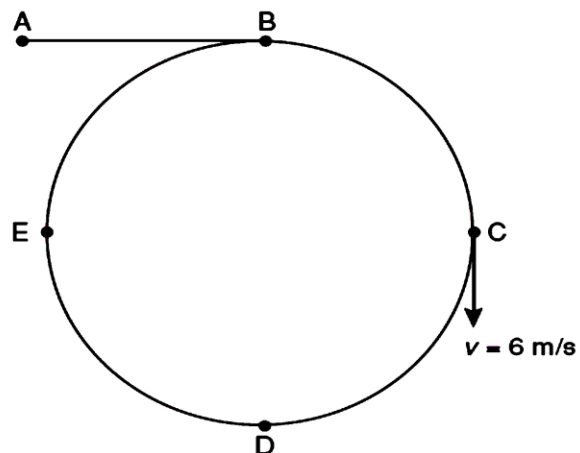

A cyclist starts at A and follows the path ABCDEB.

Fig. 1.1

The speed-time graph is shown in Fig. 1.2.

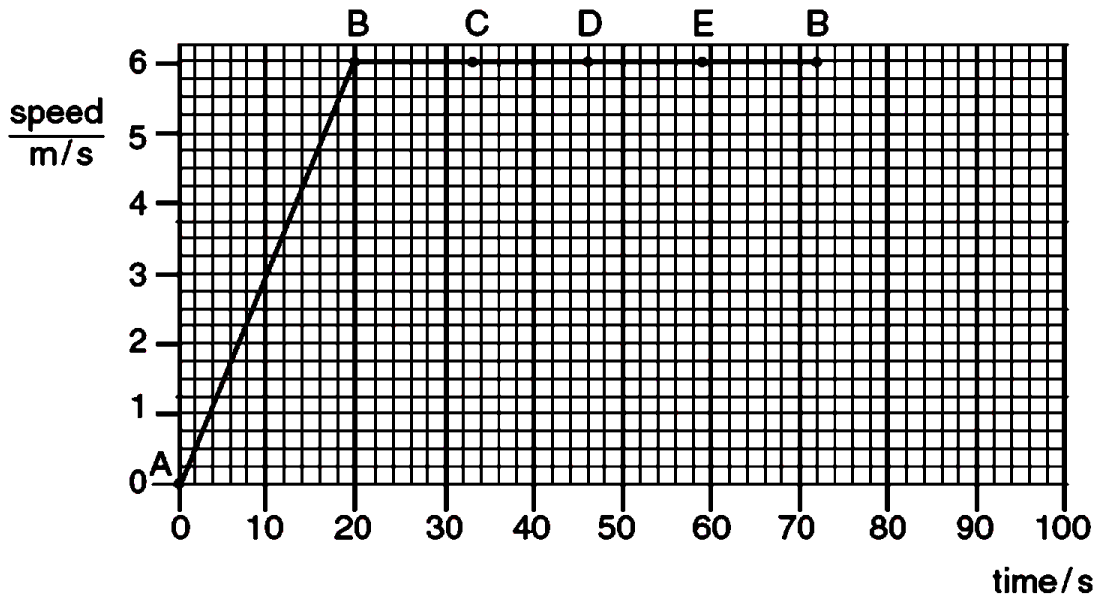

**Fig. 1.2**

**(a)** Use information from Fig. 1.1 and Fig. 1.2 to describe the motion of the cyclist

**(i)** along AB,

.....

**(ii)** along BCDEB.

.....

.....

**b)** The velocity  $v$  of the cyclist at C is shown in Fig. 1.1.

State one similarity and one difference between the velocity at C and the velocity at E.

similarity .....

difference .....

**(c)** Calculate

**(i)** the distance along the cycle track from A to B,

distance = .....

**(ii)** the circumference of the circular part of the track.

circumference = .....

24. Fig. 2.1 shows a rock that is falling from the top of a cliff into the river below.

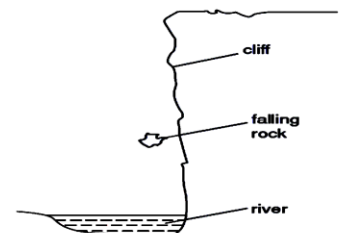

**Fig. 2.1**

**(a)** The mass of the rock is 75 kg. The acceleration of free fall is  $10 \text{ m/s}^2$ .

Calculate the weight of the rock.

weight = .....

- (b) The rock falls from rest through a distance of 15 m before it hits the water. Calculate its kinetic energy just before hitting the water. Show your working.

kinetic energy = .....

- (c) The rock hits the water. Suggest what happens to the kinetic energy of the rock during the impact.

25. A large spring is repeatedly stretched by an athlete to increase the strength of his arms. Fig. 3.1 is a table showing the force required to stretch the spring.

extension of spring/m	0.096	0.192	0.288	0.384
force exerted to produce extension/N	250	500	750	1000

**Fig. 3.1**

- (a) (i) State Hooke's law.

.....  
 .....

- (ii) Use the results in Fig. 3.1 to show that the spring obeys Hooke's law.

- (b) Another athlete using a different spring exerts an **average** force of 400N to enable her to extend the spring by 0.210 m.

- (i) Calculate the work done by this athlete in extending the spring once.

work done = .....

- (ii) She is able to extend the spring by this amount and to release it 24 times in 60 s.

Calculate the power used by this athlete while doing this exercise.

power = .....

26. The diagrams show the times on a stop clock at the beginning and at the end of an experiment.

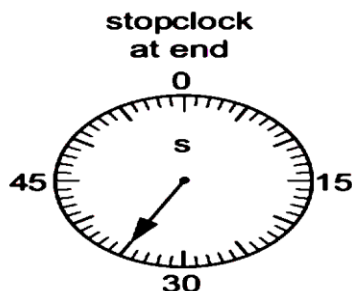

How long did the experiment take?

- A) 10 s                      B) 25 s                      C) 35 s                      D) 45 s

27. Which speed / time graph applies to an object at rest?

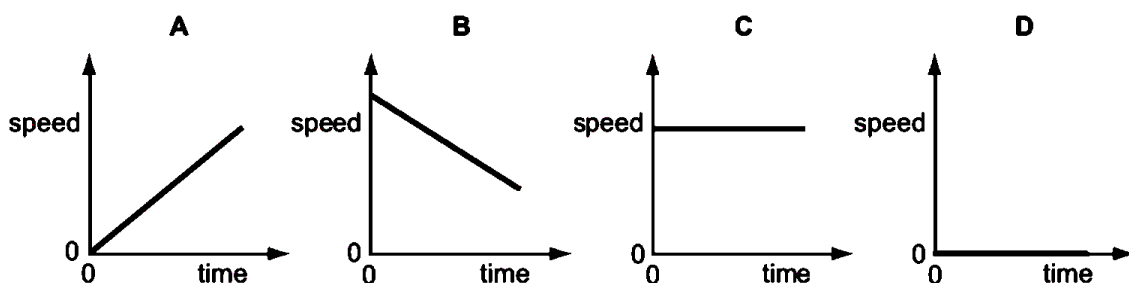

28. A spring is stretched by hanging a piece of metal from it.

What is the name given to the force that stretches the spring?

- A friction  
B mass  
C pressure  
D weight

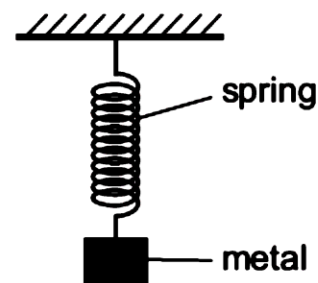

29. The diagram shows some liquid in a measuring cylinder. The mass of the liquid is 16 g.

What is the density of the liquid?

- A)  $320 \text{ g / cm}^3$                       B)  $36 \text{ g / cm}^3$                       C)  $1.25 \text{ g / cm}^3$                       D)  $0.8 \text{ g / cm}^3$

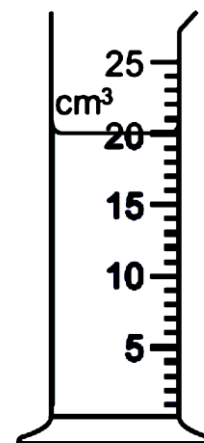

30. In an experiment, forces are applied to a spring as shown in Fig. 2.1a. The results of this experiment are shown in Fig. 2.1b.

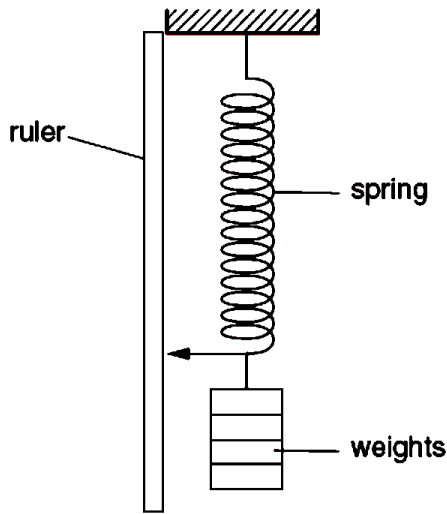

**Fig. 2.1a**

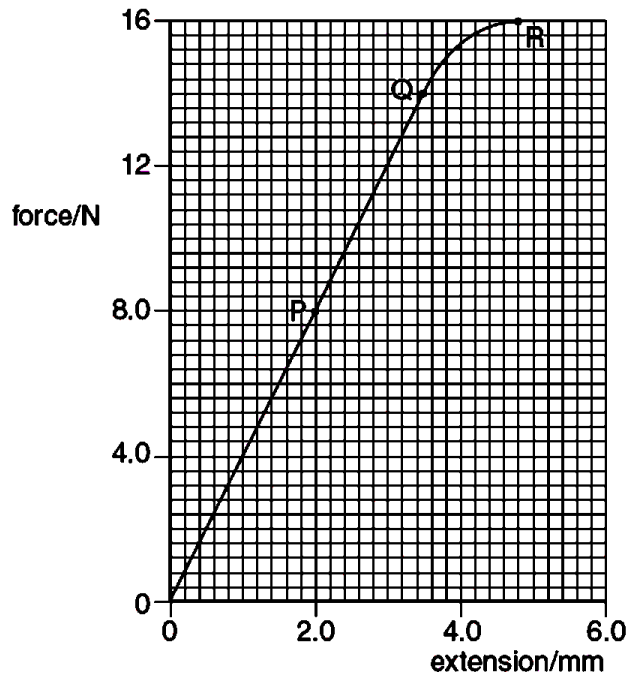

**Fig. 2.1b**

(a) What is the name given to the point marked Q on Fig. 2.1b?

(b) For the part OP of the graph, the spring obeys Hooke’s Law. State what this means.

(c) The spring is stretched until the force and extension are shown by the point R on the graph. Compare how the spring stretches, as shown by the part of the graph OQ, with that shown by QR.

(d) The part OP of the graph shows the spring stretching according to the expression

$$F = kx.$$

Use values from the graph to calculate the value of  $k$ .

$k =$  .....

31.

Which combination of forces would result in the car moving at constant speed?

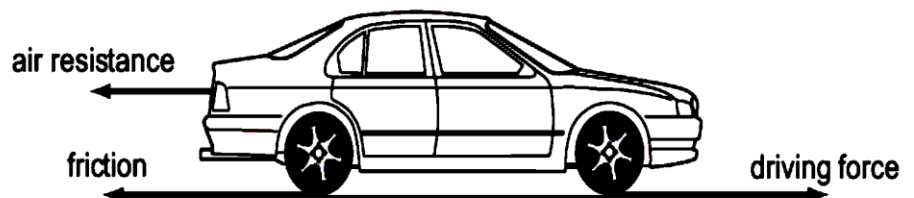

	air resistance	friction	driving force
<b>A</b>	200 N	1000 N	800 N
<b>B</b>	800 N	1000 N	200 N
<b>C</b>	800 N	200 N	1000 N
<b>D</b>	1000 N	200 N	800 N

32. A child pushes a toy car along a level floor and then lets it go.  
As the car slows down, what is the main energy change?

- A from chemical to heat
- B from chemical to kinetic
- C from kinetic to gravitational (potential)
- D from kinetic to heat

33. Fig. 1.1 represents the motion of a car along a straight road. As the car approaches a small town, it slows down. The car travels at a constant speed from the start of the town to the end of the town. After passing through the town, the car speeds up.

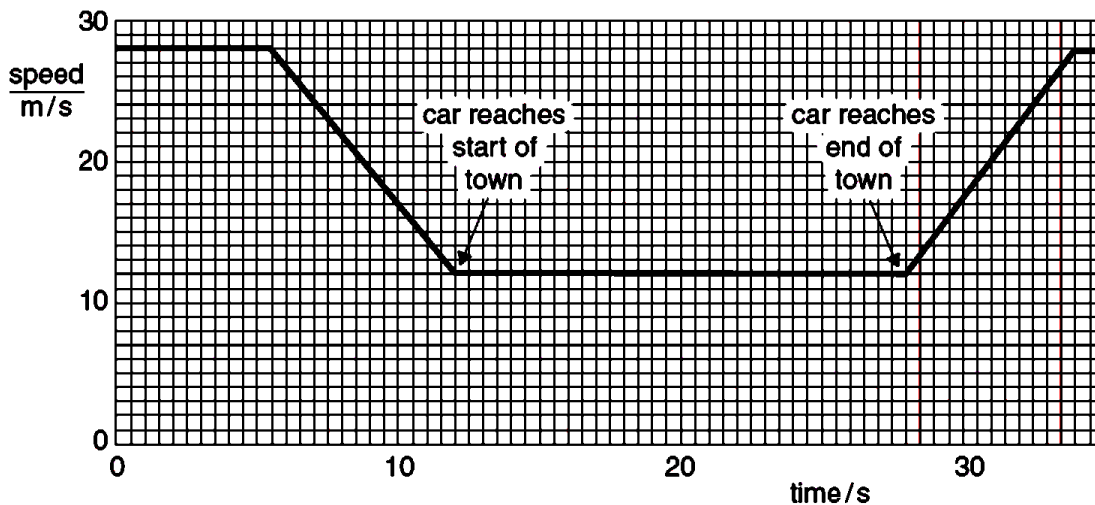

**Fig. 1.1**

(a) (i) Determine the speed of the car in the town.  
speed = .....

(ii) Determine the time taken by the car to pass through the town.  
time taken = .....

(iii) Calculate the distance travelled by the car in the town.  
distance = .....

(b) The car accelerates after passing through the town.  
 Calculate the acceleration. Give the unit of your answer.  
 acceleration = .....

34. Electricity can be obtained from different energy resources.  
 Which energy resource is used to obtain electricity without producing heat to boil water?  
 A coal  
 B geothermal  
 C hydroelectric  
 D nuclear

35. Which property of an object cannot be changed by a force?  
 A its mass  
 B its motion  
 C its shape  
 D its size

36. The diagram shows the level of liquid in a measuring cylinder.

What is the volume of the liquid?

- A) 24 cm<sup>3</sup>
- B) 28 cm<sup>3</sup>
- C) 29 cm<sup>3</sup>
- D) 32 cm<sup>3</sup>

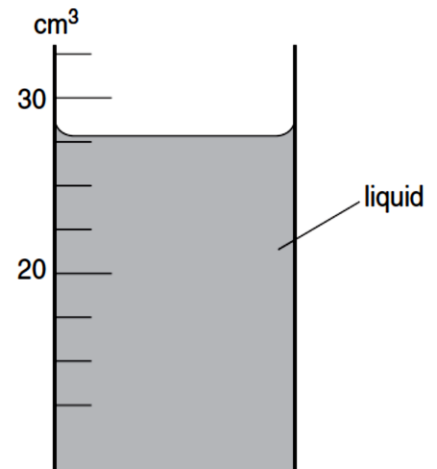

37. A cylindrical can is rolled along the ruler shown in the diagram.

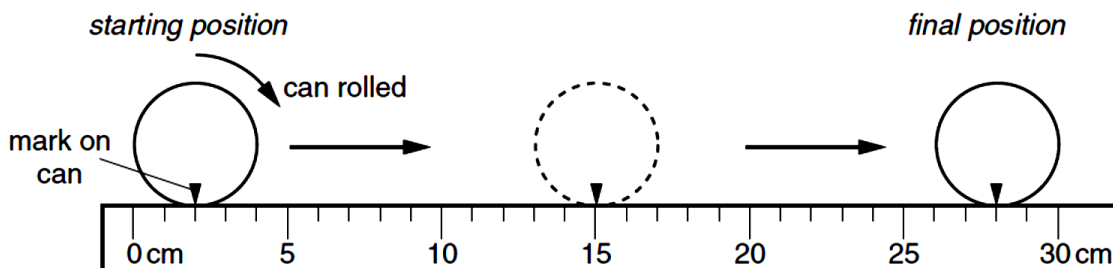

The can rolls over twice.  
 What is the circumference (distance all round) of the can?

- A) 13 cm
- B) 14 cm
- C) 26 cm
- D) 28 cm



38. Two objects X and Y are placed on a beam as shown. The beam balances on a pivot at its centre.

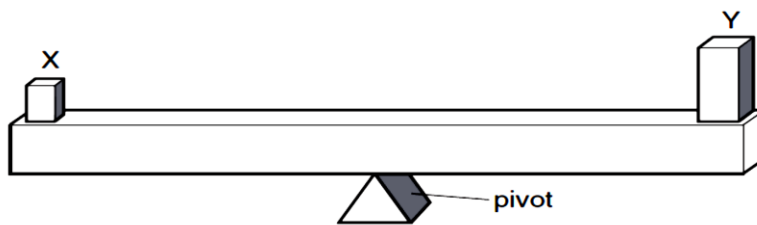

What does this show about X and Y?

- A They have the same mass and the same density.
- B They have the same mass and the same weight.
- C They have the same volume and the same density.
- D They have the same volume and the same weight.

39. A shop-keeper places two identical blocks of cheese on a set of scales and notices that their combined mass is 240 g. Each block measures 2.0 cm x 5.0 cm x 10.0 cm.

What is the density of the cheese?

- A 0.42 g / cm<sup>3</sup>
- B 0.83 g / cm<sup>3</sup>
- C 1.2 g / cm<sup>3</sup>
- D 2.4 g / cm<sup>3</sup>

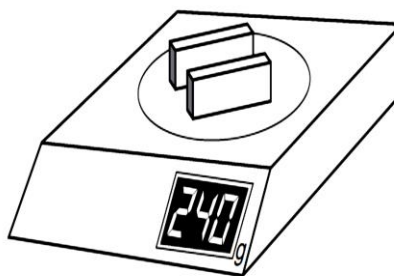

40. The diagram shows a stopwatch, originally set at 00:00.

When a car was first seen, the stop-start button was pressed. When the car passed the observer, the stopwatch showed 01:06.

How long did the car take to reach the observer?

- A 1.06 seconds
- B 6 seconds
- C 66 seconds
- D 106 seconds

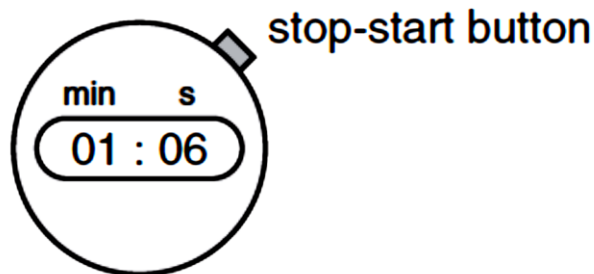

41. In an experiment, six identical bags of flour are balanced by a 9 kg mass.

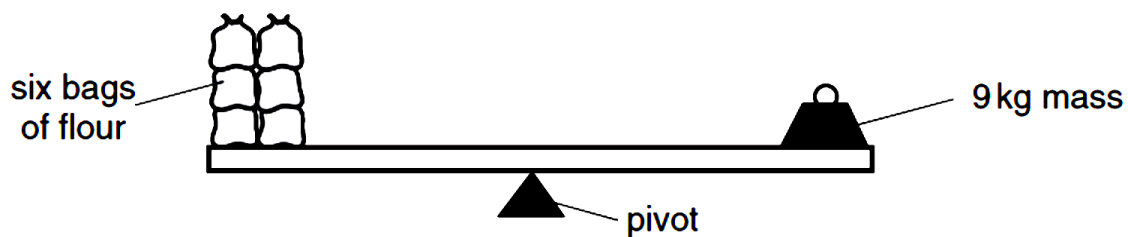

Two bags of flour are removed. What mass will balance the remaining bags?

- A) 3 kg
- B) 6 kg
- C) 7 kg
- D) 9 kg

42. Which of the following is **not** necessary when using a measuring cylinder to measure the volume of a quantity of water?

- A making sure that the measuring cylinder is vertical
- B making sure that your eye is level with the liquid surface
- C reading the bottom of the meniscus
- D using the largest measuring cylinder possible

43. A pendulum is set in motion and 20 complete swings are timed. The time measured is 30 s. What is the time for one complete swing of the pendulum?

- A) 0.67 s
- B) 0.75 s
- C) 1.5 s
- D) 3.0 s

44. A beam is pivoted at its centre. Two masses are suspended at equal distances from the pivot as shown in the diagram.

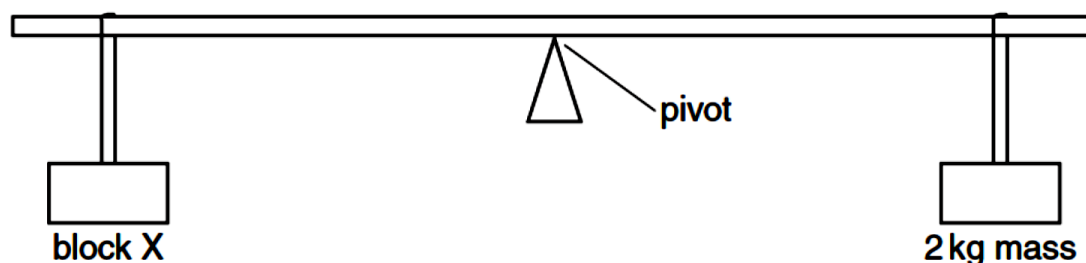

Which statement is correct?

- A If X has a mass of exactly 2 kg, it will rise.
- B If X has a mass of less than 2 kg, it will fall.
- C If X has a mass of more than 2 kg, it will fall.
- D If X has a mass of more than 2 kg, it will rise.

45. A student tries to find the density of a metal block. First he measures the weight with a forcemeter (spring balance). Next he measures the sides of the block using a rule, in order to calculate the volume of the block. Finally he divides the weight by the volume to find the density.

The student has made a mistake.

Why does his method **not** give the density?

- A Density is volume divided by weight.
- B He should have measured the surface area, not the volume.
- C He should have used the mass in his calculation, not the weight.
- D Weight is not measured with a forcemeter (spring balance).

46. Two forces act on an object.

In which situation is it **impossible** for the object to be in equilibrium?

- A The two forces act in the same direction.
- B The two forces act through the same point.
- C The two forces are of the same type.
- D The two forces are the same size.

47. A glass tank contains some water.

The length QR and the width RS of the tank are known. What other distance needs to be measured in order to be able to calculate the volume of the water?

- A) ST
- B) SV
- C) TU
- D) TV

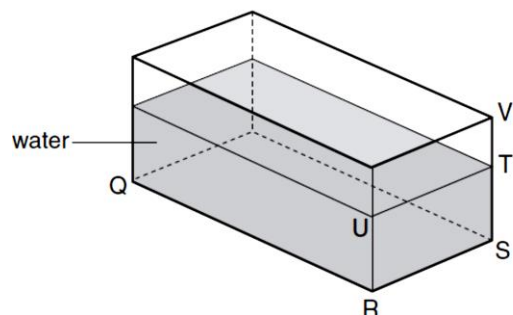

48. Three children, X, Y and Z, are using a see-saw to compare their weights.

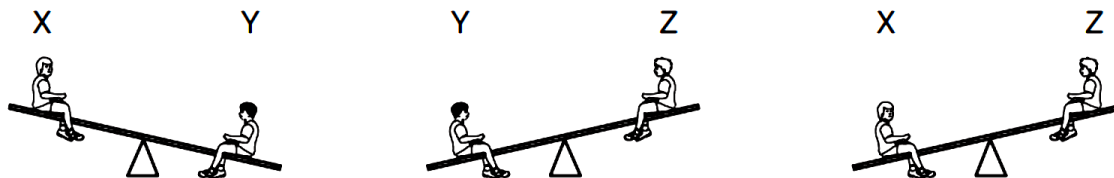

Which line in the table shows the correct order of the children's weights?

	heaviest	←————→	lightest
<b>A</b>	X	Y	Z
<b>B</b>	X	Z	Y
<b>C</b>	Y	X	Z
<b>D</b>	Y	Z	X

49. What apparatus is needed to determine the density of a regularly-shaped block?

- A** a balance and a ruler
- B** a balance and a forcemeter (spring balance)
- C** a measuring cylinder and a ruler
- D** a measuring cylinder and a beaker

50. A piece of cotton is measured between two points on a ruler.

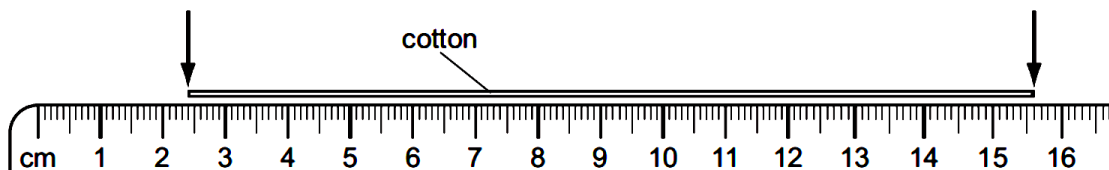

When the length of cotton is wound closely around a pen, it goes round six times.



What is the distance once round the pen?

- A) 2.2cm
- B) 2.6cm
- C) 13.2cm
- D) 15.6cm

51. The weights of four objects, 1 to 4, are compared using a balance.



Which object is the lightest?

A) object 1

B) object 2

C) object 3

D) object 4

52. A decorator wishes to calculate the area of a bathroom tile so that he can estimate the amount of adhesive that he needs to buy.

What must he use?

A a measuring cylinder only

B a ruler only

C a measuring cylinder and a clock only

D a measuring cylinder and a ruler only

53. The same mass of four different liquids is placed in some measuring cylinders.

Which measuring cylinder contains the liquid with the greatest density?

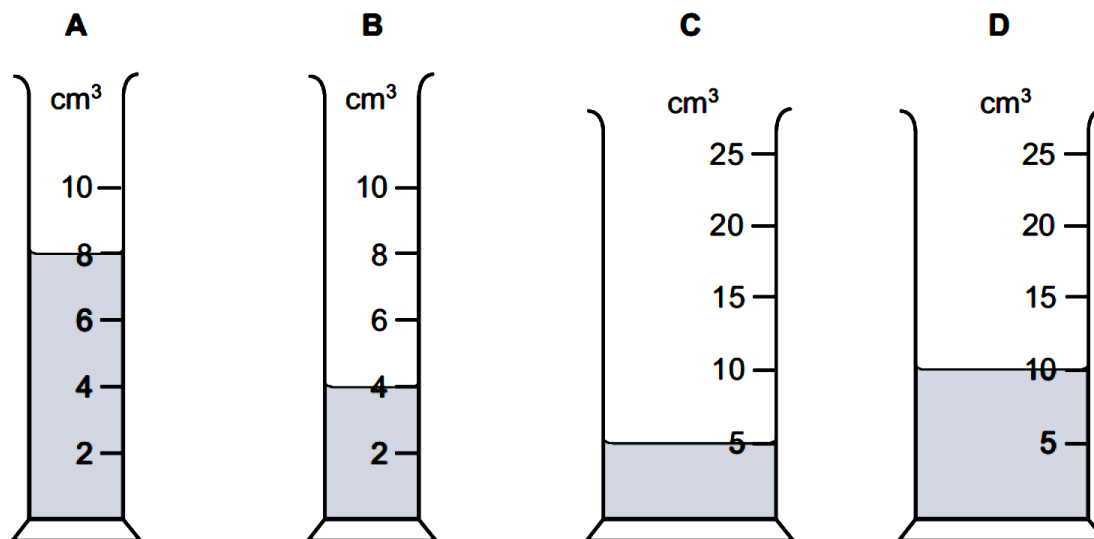

54. The diagram shows an enlarged drawing of the end of a metre rule. It is being used to measure the length of a small feather.

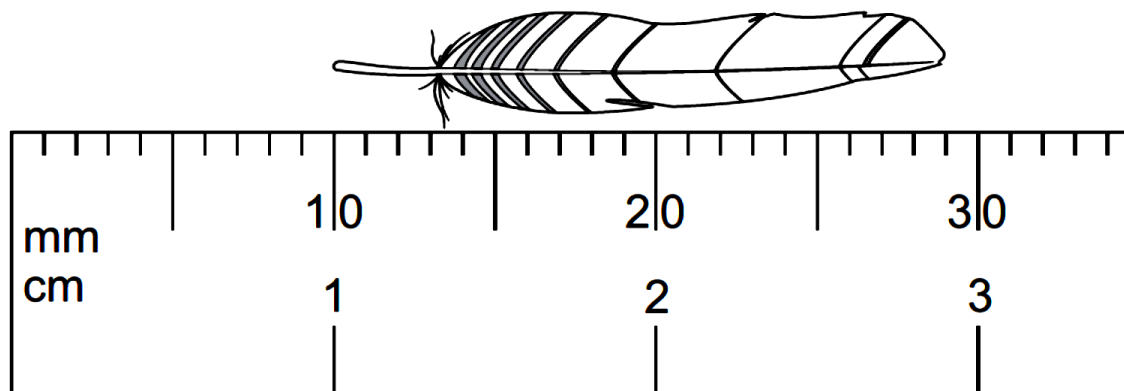

What is the length of the feather?

A 19 mm

B 29 mm

C 19 cm

D 29 cm

55. Which statement about mass and weight is correct?

A Mass and weight are both forces.

B Neither mass nor weight is a force.

C Only mass is a force.

D Only weight is a force.

56. (a) Complete the table below to identify the physical quantities as scalars or vectors.

physical quantity	scalar or vector
speed	
velocity	
distance	
force	
kinetic energy	

57. In a race, a car travels 60 times around a 3.6 km track. This takes 2.4 hours.

What is the average speed of the car?

A 1.5 km / h

B 90 km / h

C 144 km / h

D 216 km / h



62. A student is told to measure the density of a liquid and also of a large cube of metal. Which pieces of equipment are sufficient to be able to take the measurements needed?

- A balance, measuring cylinder and ruler
- B balance and thermometer
- C measuring cylinder and ruler
- D measuring cylinder, ruler and thermometer

63. Which combination of forces produces a resultant force acting towards the right?

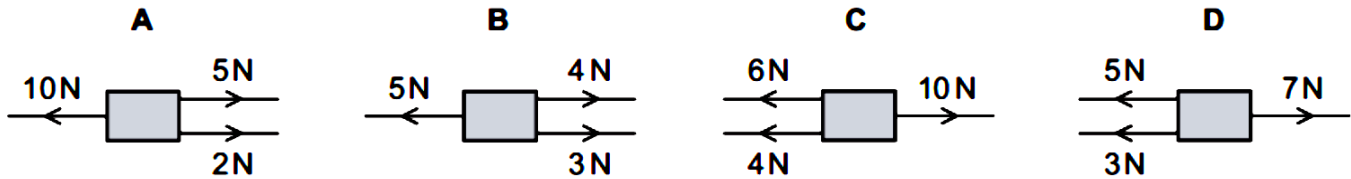

64. (a) Define *acceleration*. Explain any symbols in your definition.

.....  
 .....[1]

(b) Fig. 1.1 shows a graph of speed against time for a train. After 100 s the train stops at a station.

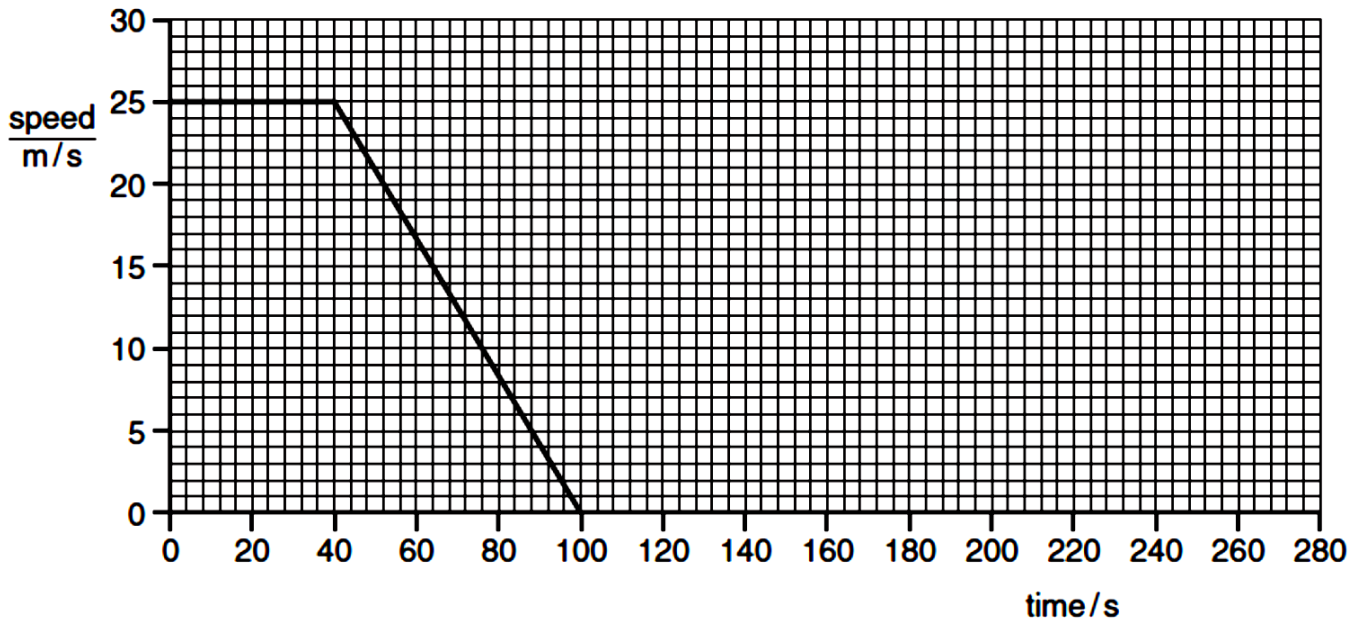

**Fig. 1.1**

(i) For the time interval between 40 s and 100 s, calculate the distance travelled by the train.

distance = .....[2]

(ii) The train stops for 80 s, then accelerates to 30 m / s with an acceleration of 0.60 m / s<sup>2</sup>. It then travels at constant speed.

Complete the graph for the interval 100 s to 280 s, showing your calculations in the space below. [5]





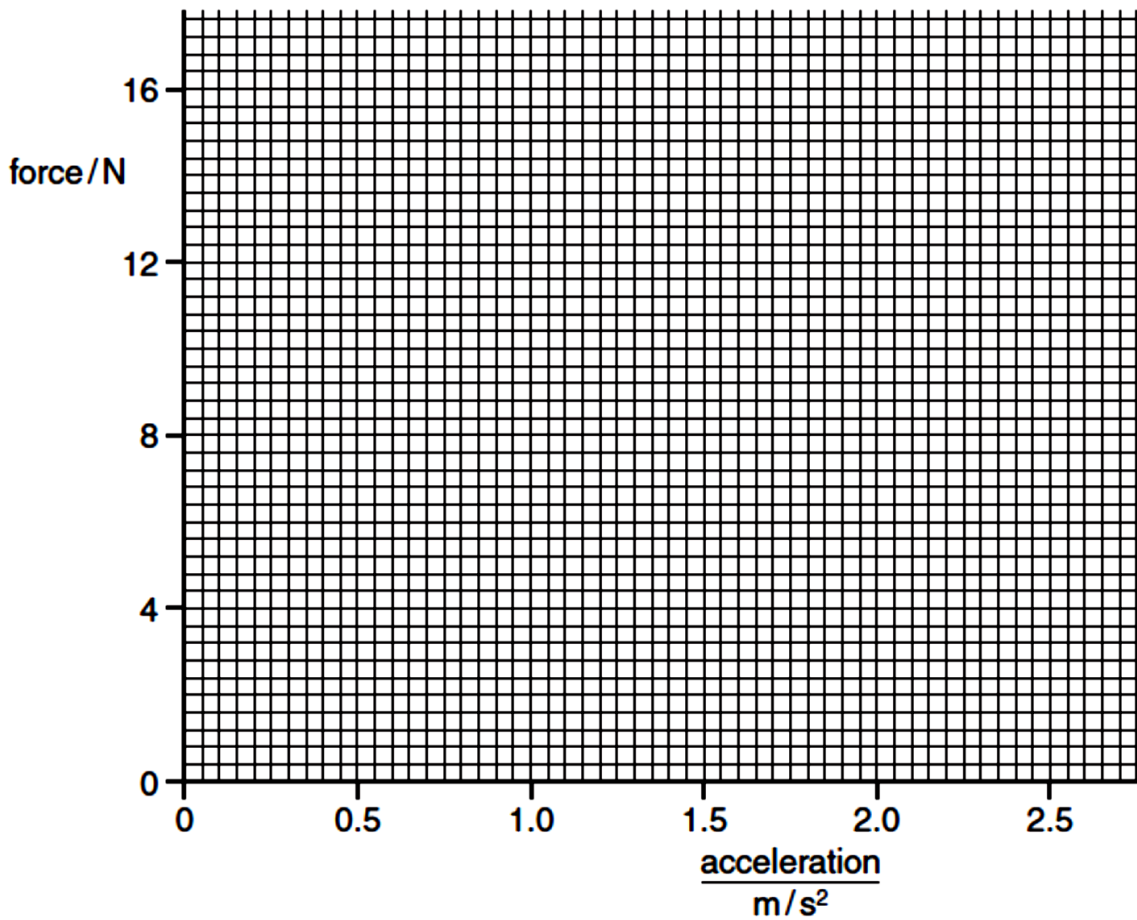

**Fig. 1.2**

**(b)** The graph shows that below a certain force there is no acceleration.

**(i)** Find the value of this force. .... [1]

**(ii)** A force smaller than that in **(b)(i)** is applied to the stationary trolley. Suggest what happens to the trolley, if anything.

.....[1]

**(c)** Show that the gradient of your graph is about 5.7.

gradient = .....[1]

**(d) (i)** State the equation that links resultant force  $F$ , mass  $m$  and acceleration  $a$ . [1]

**(ii)** Use your gradient from **(c)** to find the mass of the trolley.

mass = .....[2]

**(e)** On Fig. 1.3, sketch a speed / time graph for a trolley with constant acceleration.



**Fig. 1.3**

67. The diagram shows a balance being used to find the weight of a baby. The weight of the basket can be ignored.  
At equilibrium, the pivot is nearer to the weight  $W$  than to the baby.

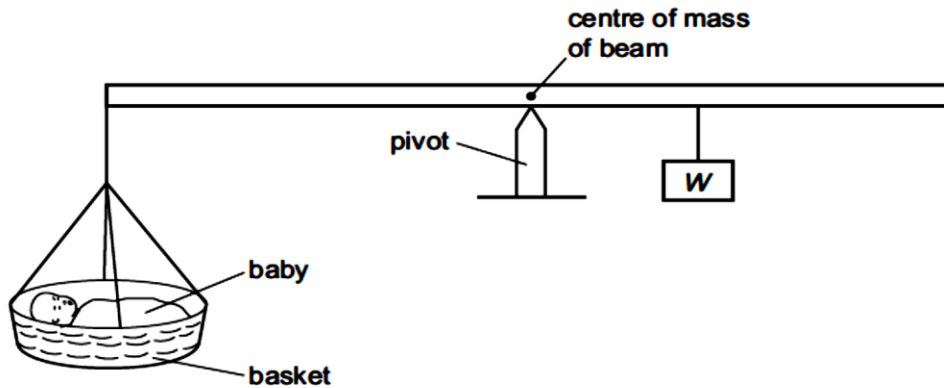

What is the weight of the baby?  
 A less than  $W$   
 B more than  $W$   
 C  $W$   
 D impossible to tell

68. A cube of side 2.0 cm is placed on a balance.

What is the density of the cube?  
 A 0.90 g / cm<sup>3</sup>  
 B 1.2 g / cm<sup>3</sup>  
 C 1.8 g / cm<sup>3</sup>  
 D 3.6 g / cm<sup>3</sup>

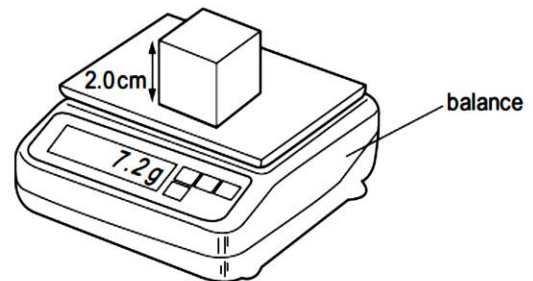

69. Which energy resource is used to generate electricity by first boiling water?  
 A hydroelectric  
 B nuclear fission  
 C tides  
 D waves

70. The period of the vertical oscillations of a mass hanging from a spring is known to be constant.  
**(a)** A student times single oscillations with a stopwatch. In 10 separate measurements, the stopwatch readings were:  
 1.8 s, 1.9 s, 1.7 s, 1.9 s, 1.8 s, 1.8 s, 1.9 s, 1.7 s, 1.8 s, 1.8 s.

What is the best value obtainable from these readings for the time of one oscillation?

Explain how you arrive at your answer.

best value = .....  
 explanation .....

..... [1]

JUNE 2012 P.31

**(b)** Describe how, using the same stopwatch, the student can find the period of oscillation more accurately.

.....  
.....  
.....  
.....  
.....  
.....  
..... [4]

71. Fig. 1.1 is a distance / time graph showing the motion of an object.

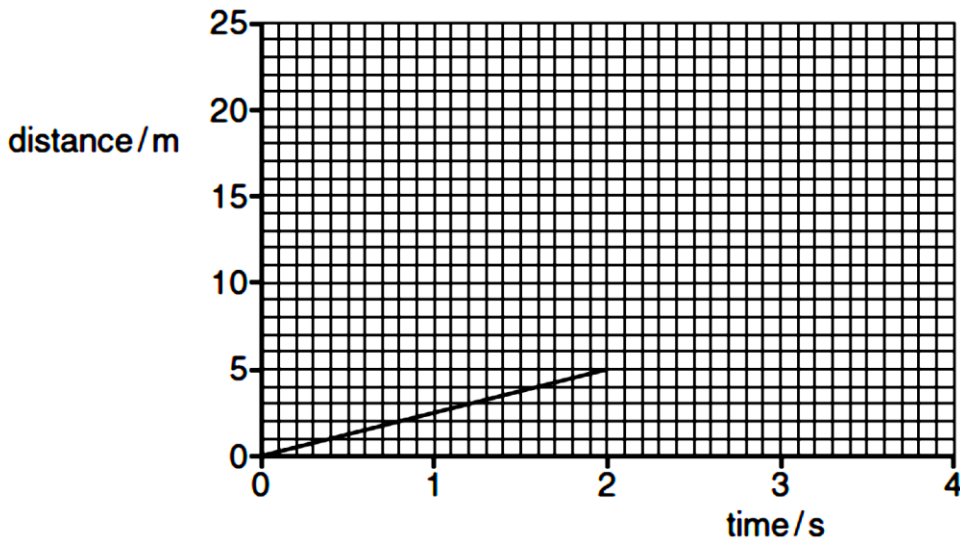

**Fig. 1.1**

**(a) (i)** Describe the motion shown for the first 2 s, calculating any relevant quantity.

.....  
..... [2]

**(ii)** After 2 s the object accelerates.

On Fig. 1.1, sketch a possible shape of the graph for the next 2 s. [1]

**(b)** Describe how a distance / time graph shows an object that is stationary.

.....  
..... [1]

72. The diagrams show the readings on a measuring cylinder before and after a small metal cube is added.

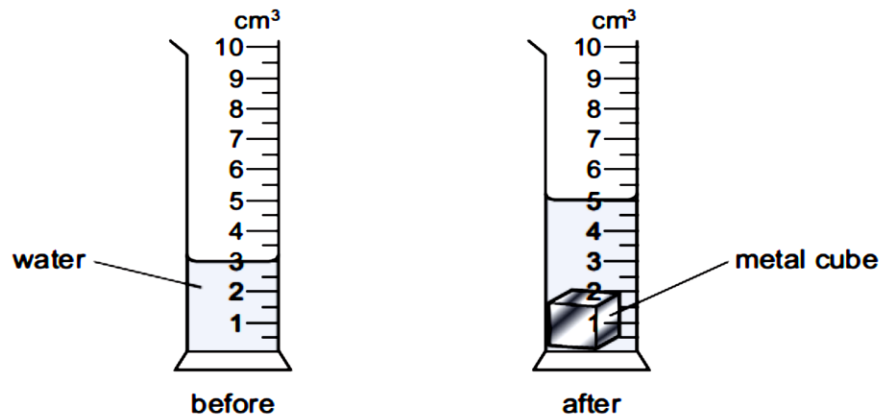

JUNE 2013 P.1

How many more identical cubes can be added to the cylinder, without causing the water to overflow? Do not include the cube already in the cylinder.

- A 1
- B 2
- C 3
- D 4

73. Which person is experiencing an acceleration?

- A a driver of a car that is braking to stop at traffic lights
- B a passenger in a train that is stationary in a railway station
- C a shopper in a large store ascending an escalator (moving stairs) at a uniform rate
- D a skydiver falling at constant speed towards the Earth

JUNE 2013 P.1

74. 1 kg sample of aluminium is stored in a laboratory. In a different laboratory, in the same town, there is a 1 kg sample of iron.

Which quantity must these two samples always have in common?

- A the same density
- B the same temperature
- C the same volume
- D the same weight

JUNE 2013 P.1

75. (a) Define *density*.

.....  
 ..... [1]

(b) The density of aluminium is  $2.70 \text{ g / cm}^3$ . The thickness of a rectangular sheet of aluminium foil varies, but is much less than 1 mm.

A student wishes to find the average thickness. She obtains the following measurements.

- mass of sheet = 60.7 g
- length of sheet = 50.0 cm
- width of sheet = 30.0 cm

JUNE 2013 P.3

Calculate the student's values for

- (i) the volume of the sheet,  
 volume = ..... [2]

(ii) the average thickness of the sheet.

thickness = ..... [2]

(c) Another student, provided with a means of cutting the sheet, decides to find its average thickness using a single measuring instrument. Assume the surfaces of the sheet are perfectly smooth.

(i) Name a measuring instrument she could use.

..... [1]

(ii) Describe the procedure she should follow to obtain an accurate value of the average thickness of the sheet.

Details of how to read the instrument are not required.

.....  
.....  
.....  
.....  
.....  
.....

[3]

76. Fig. 2.1 shows the extension-load graph for a spring.

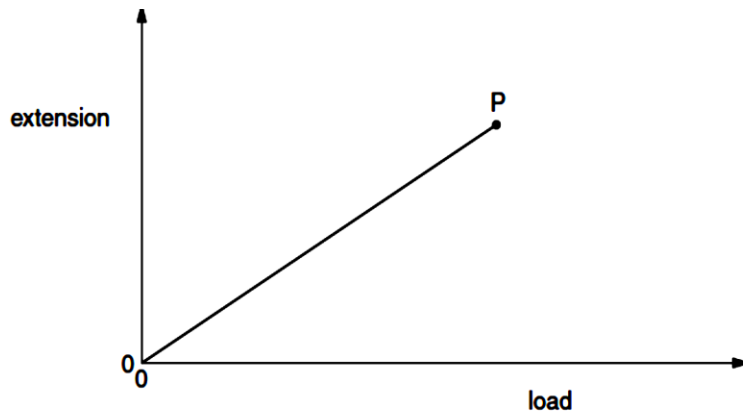

Fig. 2.1

JUNE 2013 P.32

Point P is the limit of proportionality.

(a) (i) Name the law obeyed by the spring from the origin to P.

..... [1]

(ii) Describe two features of the graph which show that the law is obeyed.

1. ....

2. .... [2]

(b) On Fig. 2.1, sketch a possible continuation of the graph when the spring is loaded beyond the limit of proportionality.

[1]

77. A train is at rest in a railway station. At time  $t = 0$ , the train starts to move forwards with an increasing speed until it reaches its maximum speed at time  $t = 48$  s.

JUNE 2013 P.33

Fig. 1.1 is the speed-time graph for the first 48 s of the journey.

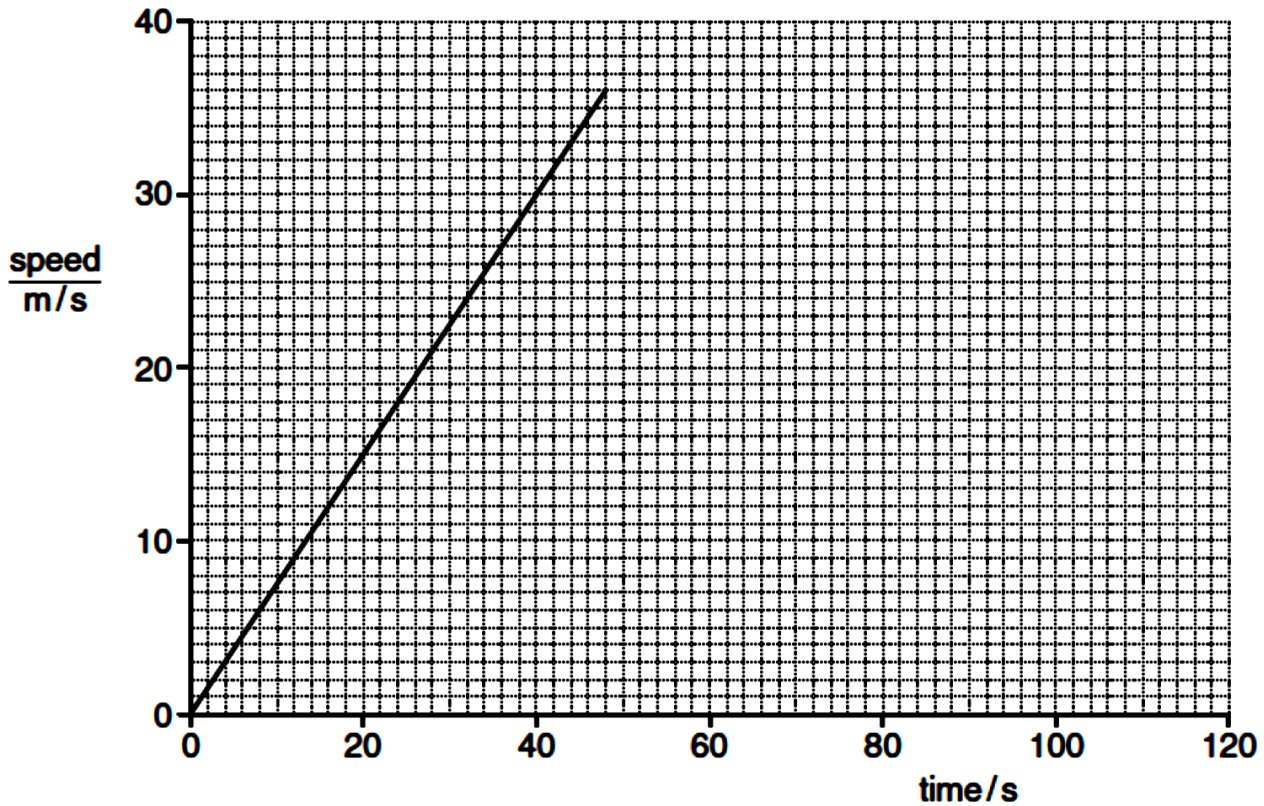

**Fig. 1.1**

**(a) (i)** State how the graph shows that, during the first 48 s of the journey, the acceleration of the train is constant.

.....

[1]

**(ii)** Calculate the acceleration of the train during the first 48 s of the journey.

acceleration = .....

[2]

**(b)** After time  $t = 48$  s, the train continues at its maximum speed for another 72 s.

**(i)** On Fig. 1.1, sketch the speed-time graph for the next 72 s of the journey.

[1]

**(ii)** Determine the total distance travelled by the train in the 120 s after it starts moving.

distance = .....

[3]

78. A bucket is full of oil. The total mass of the bucket of oil is 5.4 kg and the gravitational field strength is 10 N / kg.

NOV. 2012 P.33

(a) Calculate the total weight of the bucket of oil.

weight = .....

[1]

(b) The bucket of oil is hung from a spring of unstretched length 20 cm. The limit of proportionality of the spring is not exceeded and its length increases to 35 cm.

(i) State what is meant by the *limit of proportionality*.

.....  
 .....

[1]

(ii) The oil is poured into a measuring tank. The empty bucket stretches the spring to a length of 25 cm.

Calculate

1. the force that stretches the spring to a length of 25 cm,

force = .....

[3]

2. the mass of the oil in the measuring tank.

mass = .....

[2]

(iii) The volume of the oil in the measuring tank is 0.0045 m<sup>3</sup>. Calculate the density of the oil.

density = .....

[2]

(c) Explain, in terms of their molecules, why the density of the oil is greater than that of air.

.....  
 .....

[1]

79. A parachutist inside an aeroplane has a mass of 70 kg.

What is his mass after he has jumped from the aeroplane?

- A 0 kg
- B between 0 kg and 70 kg
- C 70 kg
- D greater than 70 kg

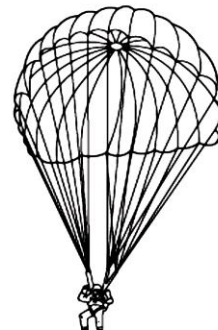

NOV. 2012 P.1

80. A person lifts boxes of equal weight on to a platform.

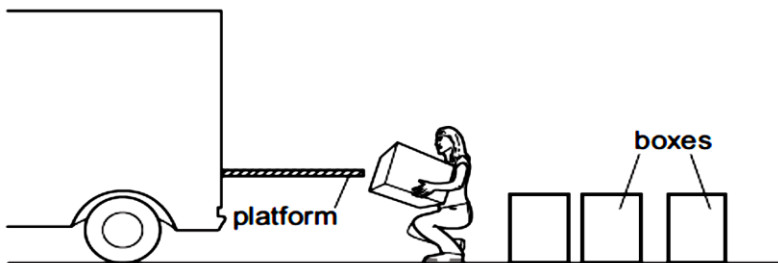

NOV. 2012 P.1

Which quantity will not affect the work done by the person?

- A the height of the platform above the ground
- B the number of boxes lifted
- C the time taken to lift the boxes
- D the weight of the boxes

81. A girl rides her bicycle along a straight level road. Fig. 2.1 shows a graph of her distance moved against time.

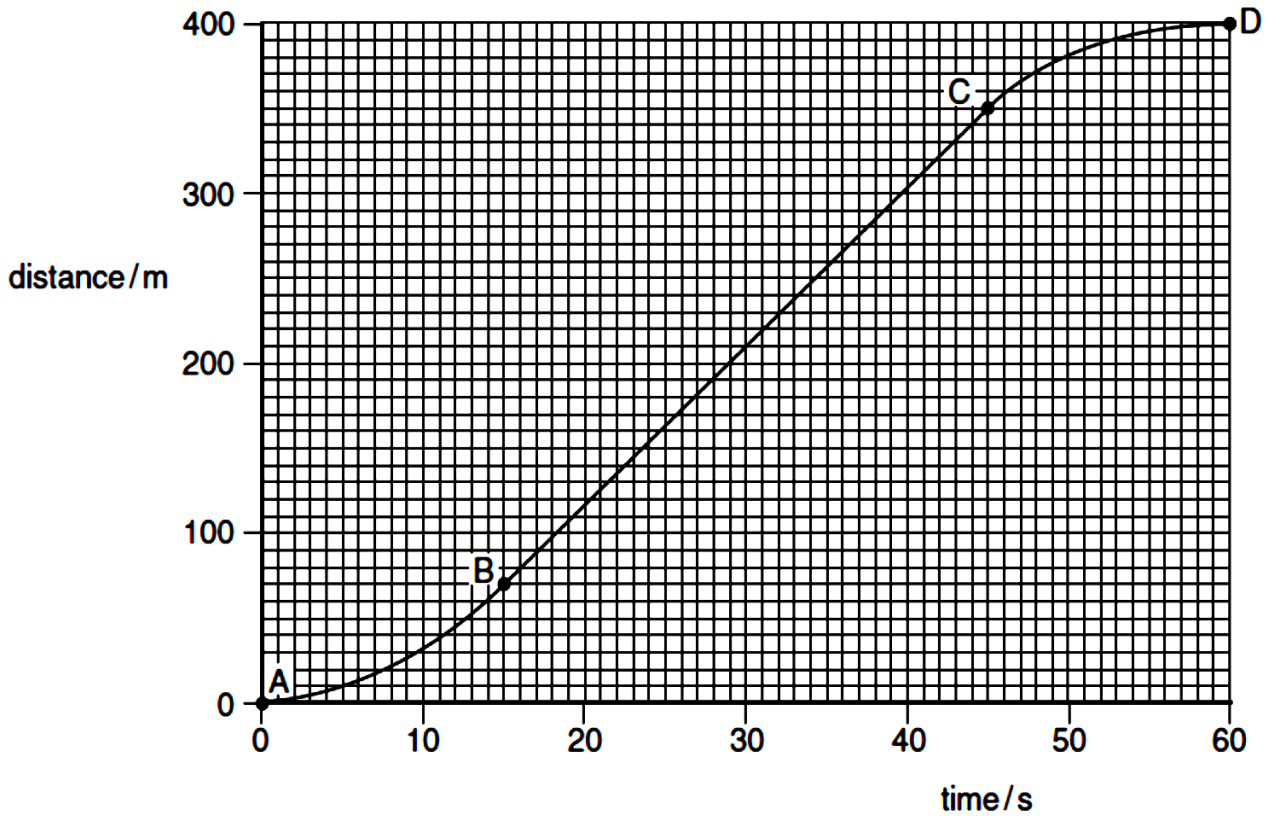

**Fig. 2.1**

**(a)** Describe her motion

**(i)** from A to B, .....

**(ii)** from B to C, .....

**(iii)** from C to D. ....

[3]

**(b)** Calculate

**(i)** her average speed from A to D,  
average speed = .....

[2]

**(ii)** her maximum speed.

maximum speed = .....

[3]

JUNE 2012 P.31



82. Fig. 2.1 shows a conveyor belt transporting a package to a raised platform. The belt is driven by a motor.

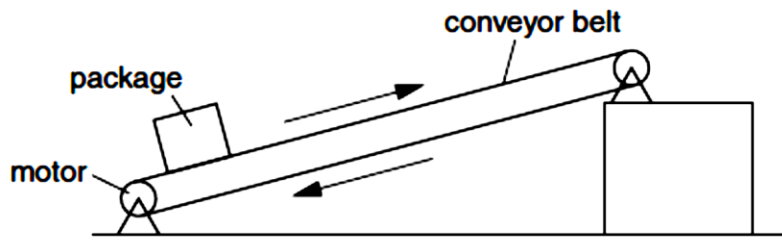

JUNE 2011 P.33

**Fig. 2.1**

(a) State **three** types of energy, other than gravitational potential energy, into which the electrical energy supplied to the motor is converted.

1. ....
2. ....
3. .... [2]

(b) The mass of the package is 36 kg. Calculate the increase in the gravitational potential energy (p.e.) of the package when it is raised through a vertical height of 2.4 m.

increase in p.e. = ..... [2]

(c) The package is raised through the vertical height of 2.4 m in 4.4 s. Calculate the power needed to raise the package.

power = ..... [2]

(d) Assume that the power available to raise packages is constant. A package of mass greater than 36 kg is raised through the same height. Suggest and explain the effect of this increase in mass on the operation of the belt.

.....  
 .....  
 .....  
 .....  
 ..... [3]

83. (a) Complete the following statement:

The moment of a force about a point is .....  
 multiplied by ..... [1]

JUNE 2011 P.33

(b) Fig. 3.1 shows a uniform iron bar B of weight 30 N and length 1.40 m. The bar is being used to lift one edge of a concrete slab S. A stone, placed 0.20 m from one end of B, acts as a pivot.

A force of 40 N pushing down at the other end of B is just enough to lift the slab and hold it as shown.

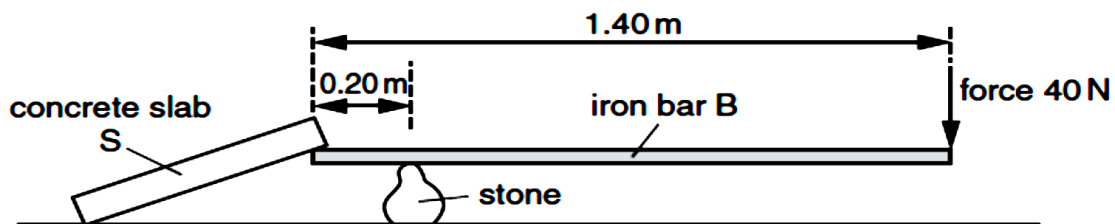

**Fig. 3.1**

(i) On Fig. 3.1, draw an arrow to show the weight of bar B acting from its centre of mass. [1]

(ii) State the distance  $d$  of the centre of mass of bar B from the pivot.  
 $d = \dots\dots\dots$  [1]

(iii) Calculate the total clockwise moment, about the pivot, of the forces acting on bar B.  
 total clockwise moment =  $\dots\dots\dots$  [3]

(iv) Calculate the downward force which the slab S exerts on the end of bar B.  
 force =  $\dots\dots\dots$  [2]

(v) Suggest a change to the arrangement in Fig. 3.1 that would reduce the force required to lift the slab.  
 $\dots\dots\dots$   
 $\dots\dots\dots$  [1]

84. The graph shows how the speed of a car changes with time.

Between which two times is the car stationary?

- A U and V  
 B V and W  
 C W and X  
 D X and Y

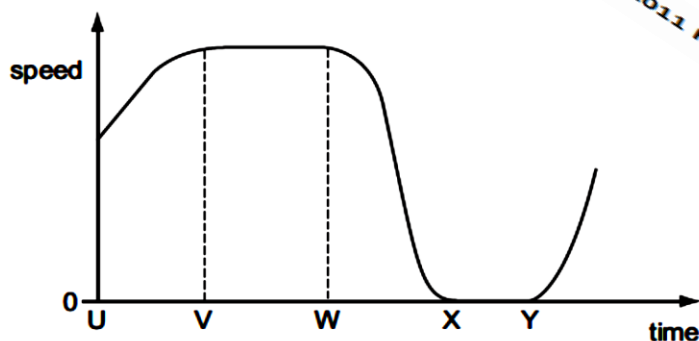

NOV. 2011 P.1

85. A measuring cylinder has a mass of 120 g when empty.

When it contains 50 cm<sup>3</sup> of a liquid, the total mass of the measuring cylinder and the liquid is 160 g.

What is the density of the liquid?

- A  $\frac{40}{50} \text{ g/cm}^3$   
 B  $\frac{50}{40} \text{ g/cm}^3$   
 C  $\frac{120}{50} \text{ g/cm}^3$   
 D  $\frac{160}{50} \text{ g/cm}^3$

JUNE 2013 P.1