



Clean Room Design Standards & Energy Optimization

Abstract	2
Clean	2
Camfil Farr Solution Systems (CFSS)	3
- CREO (Clean Room & Energy Optimization)	3
- Software Analysis Tools	3
Theory	4
- Mass Flow Balance	4
- Particulate Balance	4
- Particulate Balance Equations	5
- Different Clean Room Systems	6
Air Handling Systems	7
- Recirculation & Reduction of Velocity	7
Life Sciences Industry Standards	8
- Clean Rooms	8
- EU GGMP	10
- Outdoor Particle Concentrations	11
- Internal Particle Concentration	11
- Start-up Concentration	12
Air Filters	13
- HVAC Air Filter Standards	14
Summary	15

Copyright Camfil Farr 2012

The contents herein are not to be copied, reproduced, printed, published, posted, displayed, incorporated, stored in or scanned into a retrieval system or database, transmitted, broadcast, bartered or sold, in whole or in part without the prior express written permission of Camfil Farr. Unauthorised duplication is strictly prohibited and is an infringement of National and International Copyright laws.

Abstract

Clean rooms today are high technology solutions with high or very high demands on the air cleanliness level. Not only particulate matter but also airborne molecular contaminants (AMC) are addressed in more and more applications. Therefore it is important to estimate the level of air cleanliness in the cases of new production of, or reconstruction of a clean room.

The air cleanliness level in a clean room is dependent on the quality of the supply air, contamination sources and the design of the ventilation system. Due to this it is difficult to estimate the final cleanliness class, but it can be done either by using mathematical algorithms or by experimental mock up studies. The most cost effective and fastest approach is to use computer aided analysis. Today fluid dynamic calculations (CFD) are used to determine airflow patterns, and in certain respect also analyzing the contamination spread, this is however time consuming to do.

A faster and efficient method is to use mathematical algorithms describing the relationship between the cleanliness and the most important variables in a general model of a system.

Camfil Farr has developed several software applications to help the constructor/engineer to compare different solutions and evaluate the impact on the clean room class depending on what components and room design is used. It is easy to estimate the result of outdoor environments, room activity, different particle sizes and contamination sources. Specific software has been developed for AMC related applications and is available from Camfil Farr AC specialists.

The heart of the clean room consists of the filters which can be selected in different qualities in different locations in the clean room. This article describes the theory and the basic data for calculation of particle concentration and can be used for estimating the cleanliness class for a certain clean room design.

Clean

This software application can help the designer of a clean room to estimate the cleanliness class in clean rooms or in other spaces (offices, etc.) using different types of air filters. Depending on the number of people, the activity in the room, the ventilation system and the filter selection the clean room class is calculated. This is a very quick and accurate tool for the clean room designer to make the first estimation on what filter selection is needed. Comparison up to three different solutions can be obtained with just a few inputs.

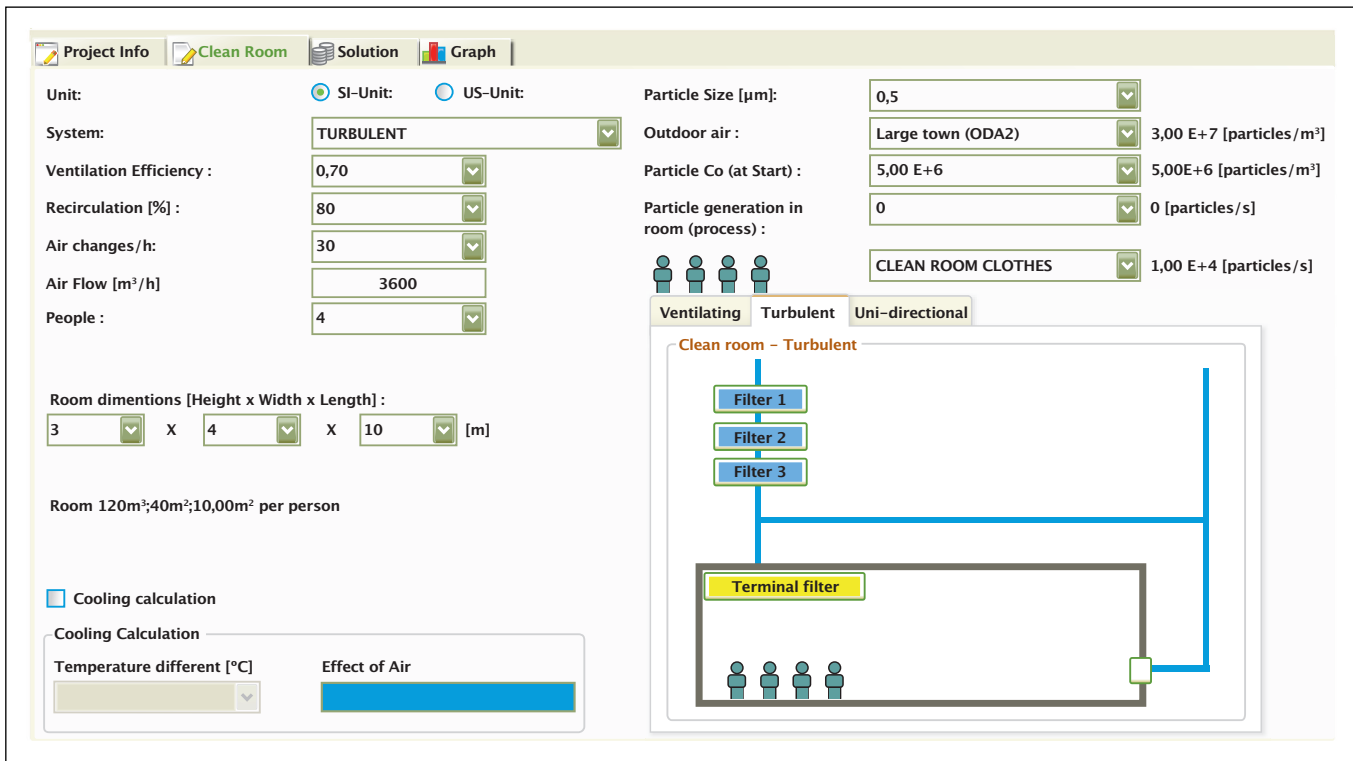

Clean room design software simplifies clean room design and air filter selection using industry standards and design criteria.

Camfil Farr Solution System (CFSS)

The Camfil Farr Solution system is a software platform for various analysis tools for Air filtration performance, Life cycle cost and other calculations. On this platform several applications for clean room applications are available:

CREO (Clean Room and Energy Optimization)

The CREO (Clean Room and Energy Optimization) application enables the user to create a customized clean room application. The application allows the user to calculate the Life Cycle Cost and cleanliness class for different Clean room designs. Different Cleanroom configurations can be analyzed ranging from ventilating to unidirectional (Laminar flow) installations. Expected operational time of filters, energy consumption and the total operating cost for the filter installation is calculated. Wide ranges of reports are available, including Cleanroom classifications as well as specifications for selected products. Additional information such as CO₂ emissions and efficiency of the filter system is also available.

Software analysis tools

It is very difficult to make an exact calculation of clean room cleanliness level for a real situation since some variables are difficult to measure and quantify. As discussed earlier the time dependency of several terms, such as the internal particle generation, can also be very difficult to verify. The accuracy modelling of the air filter performance in clean rooms depends on the complexity of the system design and the operation. However, by using software applications developed specifically with focus on air filter performance and clean room processes a higher degree of accuracy can be obtained compared to manual calculations or the use of old practices. Rather complex systems with different types of air filters can today be analyzed. Using these tools together with knowledge of important parameters such as air filter performance, system functionality etc., will lead to useful end results. A professional software application has the opportunity to serve as an aid for the engineer or the constructor of a clean room in the prospect phase of a clean room design.

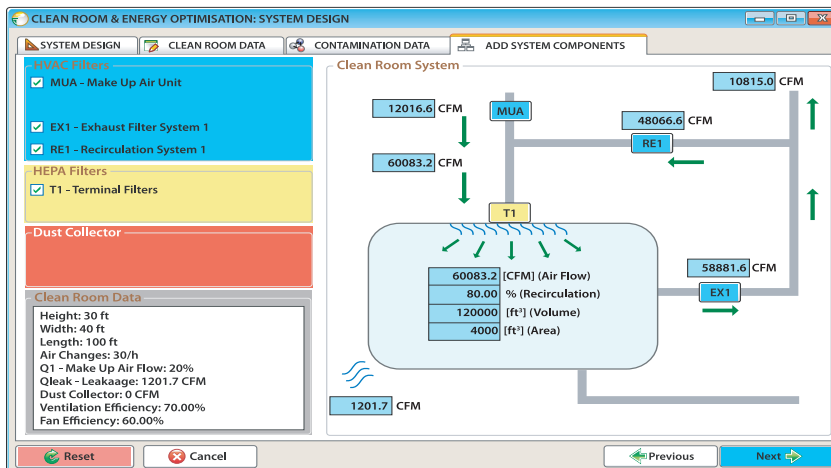

Progression screens provide graphic representation of selections. The designer can review and make adjustments to reach the desired performance level.

Camfil Farr has created CREO, Clean Room Energy Optimization, software that simplifies design, product selection and makes recommendations related to the energy use related to the air supply in the final design.

By making a first analysis on a general clean room model, the selection of appropriate clean air components is simplified and accurate based upon modern design and concepts. In addition to the room classification calculations previously reviewed, CREO has added the filtration system component pressure drop calculations to optimize the energy consumption once the desired cleanliness level is achieved.

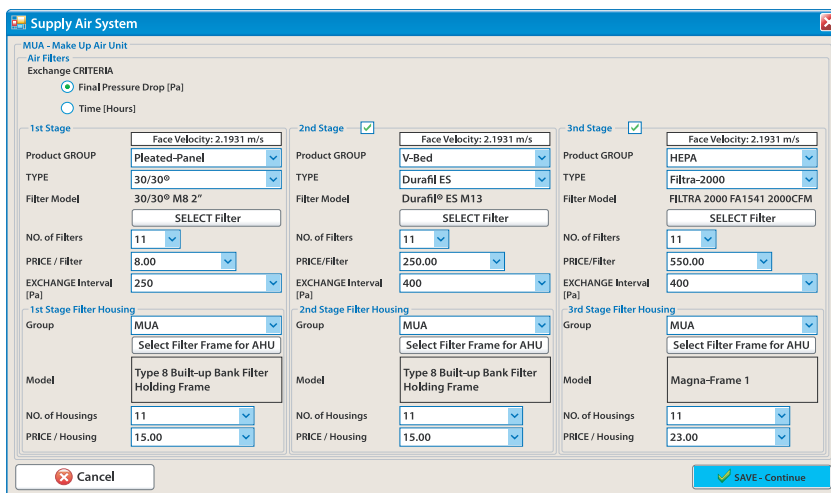

Parameter input screens are simple and straight forward taking into consideration all of the requirements detailed in this document. Product selection is simplified.

The cleanliness level in a clean room is dependent on the design of the ventilation system, and the sources of contaminants. It is possible to express the relationship with mathematical formulas but they become rather complex for larger systems. This makes it necessary to use software applications to make design evaluations for a clean room. Even without accurate data on contamination sources, the air filter performance and system functionality can be evaluated and the most important design parameters can be identified. The CFSS system provides several analysis tools to simplify and optimize air filter selection from given data.

Theory

Mass flow balance

A clean room is dependent on having a balanced airflow in order to stop contamination from entering the room as well as having an effective removal of any contamination generated inside the room (processes, accidents, human activity etc.). The mass flux law governs the airflow balance:

$$\dot{m}_{in} = \dot{m}_{out}$$

Particulate balance

The level of particle air contaminants in a room is determined by particles entering and exiting the room. However, sources inside the room especially from people and the type of garments they are wearing plays an equally if not more important role. Any particles from the process, people or other activities are contributing to the concentration inside a room. Air filters can, if correctly used, very efficiently increase the cleanliness level. Additional measures to improve the clean room class could be to use recirculation devices (air cleaners) or use a higher ratio of recirculation through filters for the complete room, install exhaust outlets close to known sources and improve the clothing on the people working in the area.

It is possible to make a mathematical model for the connection between the ventilation system design, particle sources and filter solutions and obtain results on the level of particle concentration, $C(t)$.

Figure 1 shows the mass and particulate balance in a room with the volume “V” m³. The supply air is denoted “Q” m³/s and the re-circulated air “XQ” m³/s, where “X” is the part of the supply air that is “recycled” (X is between 0 to 1). The exhaust airflow (air exiting the system) is (1-X)Q m³/s. This system model has a supply air filter (Filter “s”) with the particle efficiency “ η_s ” and a recirculating air filter (Filter “re”) with the efficiency of “ η_{re} ”. The supply air

(outdoor) particle concentration “ C_s ” [particles/m³] is the challenge aerosol concentration for filter “s”. An additional leakage into the room is denoted “q” m³/s, having the concentration “ C_{leak} ” particles/m³.

Ventilation efficiency

(contamination removal efficiency factor)

Ventilation efficiency (ϵ), or ventilation efficiency factor is the factor that describes how effective the ventilation system is in removing contaminants. This factor is also referred to as “Contamination removal

Figure 1

$$\epsilon = \frac{C_{exit} - C_s}{C(t) - C_s}$$

- “ ϵ ” : is the Ventilation efficiency (contamination removal effectiveness) factor
- “ C_{exit} ” : is the particle concentration at the exhaust (exit) air from the room
- “ C_s ” : is the particle concentration at the inlet (air supply) of the room
- “ $C(t)$ ” : is the particle concentration in the room

efficiency factor”, and can be described as:

Where:

The Ventilation efficiency is between 0 – 1, but can also be larger than 1 in certain systems, for example when exhaust system removing internal generated dust generation efficiently. Typically the factor 1 is used for efficient unidirectional systems. Typical ventilation efficiencies for different rooms can be seen in table 1.

Table 1

Ventilation Efficiency (Contamination removal effectiveness)	System	Example
$\epsilon \rightarrow \infty$	Contaminant at the outlet, the flow field does not have an influence	Efficient extraction system together with clean supply air
$\epsilon = 1$	Complete and instantaneous mixing. Contamination source does not have influence	Unidirectional clean room system
$\epsilon = 0.7$	Good removal of contaminants	Turbulent mixing clean room with good positioning of supply air and exhaust air
$\epsilon = 0.3$	Medium good removal of contaminants	Typical normal ventilating room
$\epsilon \rightarrow 0$	Contamination source in the recirculation area, bypass of supply air	Short circuited system, with very poor dilution. Supply air will not help to reduce the concentration in the clean room

The factor depends on what cleaning equipment is installed and position in the room. The spread of contaminants, how large and the position of the sources as well as the operation of the clean room are other important parameters.

As a result of turbulence or presence of non-moving air, high concentrations of contaminants can exist in certain areas of a clean room. The ventilation efficiency factor can under those circumstances be set so it would simulate these differences.

It may be difficult to accurately estimate this factor without a thorough analysis, never the less the estimation according to figure 1 may serve as a good guideline for a first evaluation.

Particle Balance Equations

The following mathematical relations can be used to describe the particle balance in a general clean room, see figure 2.

Particles are supplied to the room via:

- (1) Outdoor air (supply air): $(1-X) \cdot (1-\eta_s) \cdot Q \cdot C_s$ [particles/s]
- (2) Recycled air (return air): $X \cdot (1-\eta_{re}) \cdot Q \cdot C(t)$ [particles/s]
- (3) Leakage (into room): $q \cdot C_{leak}$ [particles/s]
- (4) Internal generation (source): S [particles/s]

Particles are removed from the room via:

- (5) Exhaust air: $(Q+q) \cdot \epsilon \cdot C(t)$ [particles/s]
- Q: airflow [m³/s]
- q: leakage into the room, airflow [m³/s]
- V: volume of room [m³]
- X: part of total airflow recirculating
- C(t): concentration in room [particles/m³]
- C₀: concentration in room at start [particles/m³]
- C_{leak}: concentration in leakage air [particles/m³]
- C_s: concentration in supply air (outdoor air) [particles/m³]
- C_∞: concentration in room equilibrium [particles/m³]
- t: time [s]
- η_s: efficiency of supply filter (outdoor air)
- η_{re}: efficiency of recirculation filter (recirculation air)
- S: particle generation inside the room [particles/s]
- ε: ventilation efficiency factor
- η: efficiency of filters (general)
- k₁, k₂: constants

Figure 2

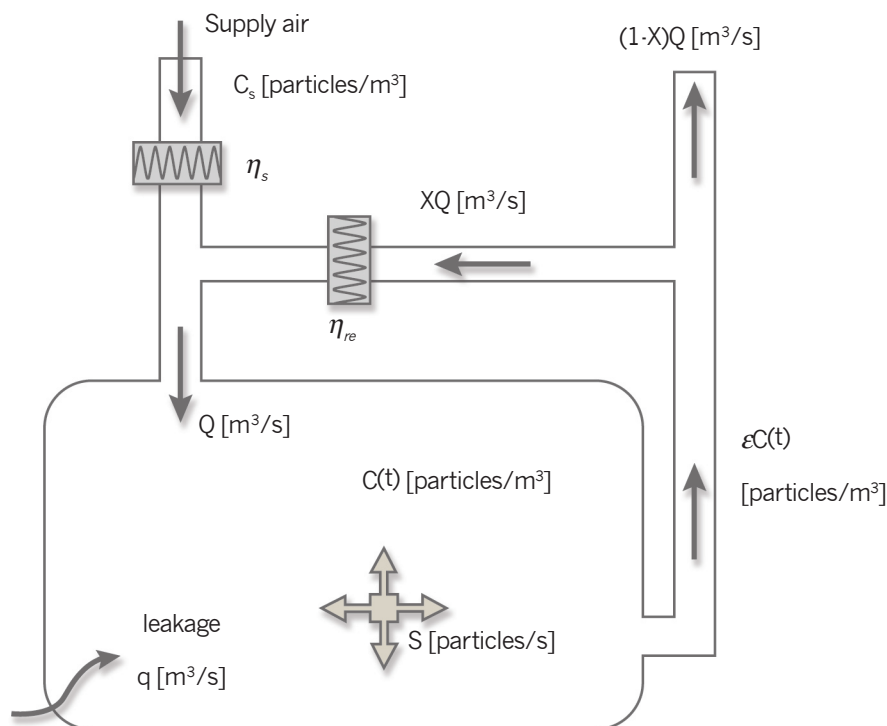

The difference between the number of particles that are removed and introduced to the room during Δt seconds will change the particle concentration by ΔC .

The change in particles in the room is then $V\Delta C$, where "V" is the volume of the room and can be expressed as:

$$(6) V\Delta C = [(1-X) \cdot (1-\eta_s) \cdot Q \cdot C_s + X(1-\eta_{re}) \cdot Q \cdot \varepsilon \cdot C(t) + q \cdot C_{leak} + S - (Q+q) \cdot \varepsilon \cdot C(t)] \Delta t$$

$$(7) k_1 = \varepsilon \cdot Q \cdot [1 + \frac{q}{Q} - X \cdot (1-\eta_{re})]$$

$$(8) k_2 = (1-X)(1-\eta_s) \cdot Q \cdot C_s + q \cdot C_{leak}$$

If $\Delta t \rightarrow 0$ equation (6), (7) and (8) becomes:

$$(9) VdC = (S - k_1 \cdot C(t) + k_2) dt$$

Integration of (9) gives:

$$(10) V \int_{C_0}^C dC = \int_{t_0}^t (S - k_1 \cdot C(t) + k_2) dt$$

$$(11) V \int_{C_0}^C \frac{dC}{(S - k_1 \cdot C(t) + k_2)} = \int_{t_0}^t dt$$

For $t_0=0$ and $C=C_0$ the following equations are obtained:

$$(12) t = \frac{V}{k_1} \ln \frac{S + k_2 - k_1 \cdot C}{S + k_2 - k_1 \cdot C_0}$$

or

$$(13) C = (C_0 - \frac{S}{k_1} - \frac{k_2}{k_1}) e^{\frac{k_1 t}{V}} + \frac{S}{k_1} + \frac{k_2}{k_1}$$

As can be seen in the equation the particle concentration is composed of two parts. One part that vary with time and another part that is independent of time. The part that has a time dependency may express a dilution process of the particle concentration and describes in that case a declination in concentration with time. When $t \rightarrow \infty$ the time dependent term will approach zero, and thus this term becomes insignificant. This case is describing a stationary clean room process which often is referred to as "the steady state of the system". However in many cases, it is necessary evaluate transient (time dependent) processes such as variance in internal particle generation or other time dependent events.

Thus, for a stationary process ($t \rightarrow \infty$) equation (12) is reduced to:

$$(14) C_{\infty} = \frac{S}{k_1} + \frac{k_2}{k_1}$$

The complexity of the equations above can be substantially simplified when one or more terms are dominating. Assumptions like constant internal particle generation, constant outdoor particle concentration (C_s) and constant concentration in leakage air (C_{leak}) are already made. In real life this is not always the case.

Different clean room systems

Clean room systems can look very different depending on the operational requirements. Air filters are used in many different places in those applications and therefore the calculation algorithms will vary from case to case.

It is possible to use equation (13) and (14) for all kinds of ventilations systems. However it is necessary to combine and group filters in a suitable manner in order to describe the filter efficiencies in the system correctly. The relation of penetrations for filters mounted in series can be described as:

$$(1-\eta) = (1-\eta_1) \cdot (1-\eta_2) \cdot (1-\eta_3) \cdot \dots \cdot (1-\eta_N)$$

Where:

N: Number of filters in series

(1- η): The total penetration of N filters

This general relationship is the key to model the filtration performance in conjunction with ventilation systems.

Air Handling Systems

There are many different types of clean room designs in the industry today. The software analysis tools developed by Camfil cover three basic designs, ventilating-, turbulent- and unidirectional (laminar) airflow systems. When selecting a system it is important to select the closest model for the real system.

The airflow (recirculation), the amount of supply air, particle composition, the room size and the ventilation efficiency (contamination removal effectiveness) are all important inputs for the modeling of the clean room.

There have been a number of studies recently published by the ISPE HVAC/Sustainability COP (Green Pharma HVAC Initiative) focused on three main areas:

- Air change rate reduction in a classified space
- Recirculation in lieu of once through (full fresh) air
- Reduction of velocity (down flow/laminar flow)

Air change rate reduction

Air change rate reduction starts with assessing cleanroom performance with ISO-14644-3, specifically classification & recovery.

- Assess risk to product & process
- Select & qualify scheme, qualify scheme by looking at the following:
 - a. Classification
 - b. Recovery

- a. Viabiles
- b. Activities & Interventions
- c. Cleaning

One study understanding the particle challenge for viable and non-viable experienced in cleanrooms has been published and is available for members of the ISPE COP.

Recirculation and reduction of velocity

The hypothesis is that 100% outside air is deemed excessive in all but the most extraordinary cases. Quantitative assessment of the air recirculation risks is possible using a combination of industrial hygiene & air filtration certification standards. An opportunity for the use of more energy efficient filters applies which can be addressed through technical assessments, significant energy saving opportunities have been identified.

Reduction of velocity in clean rooms have been applied for a number of years in the micro-electronics industry. The 'magic' 90-fpm (0.45m/s) +/- 20% from Willis Whitfield in the 1960's was a 'good guess' but today is not scientifically supported. There are specific concerns and published papers on the impracticality of measuring velocity at working height, again, energy saving opportunities as much as 20% in a Grade A space is thought possible here.

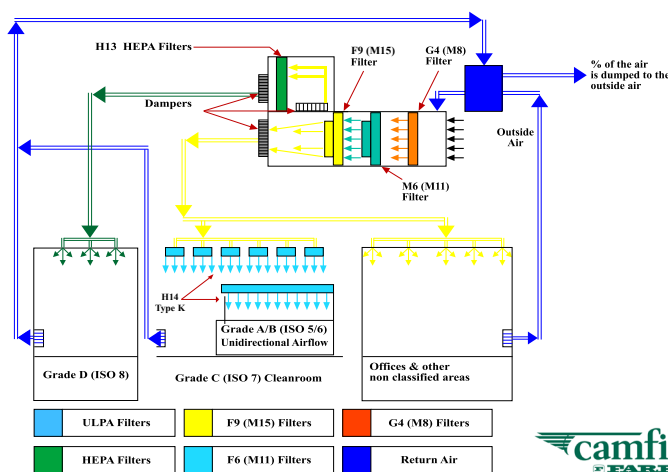
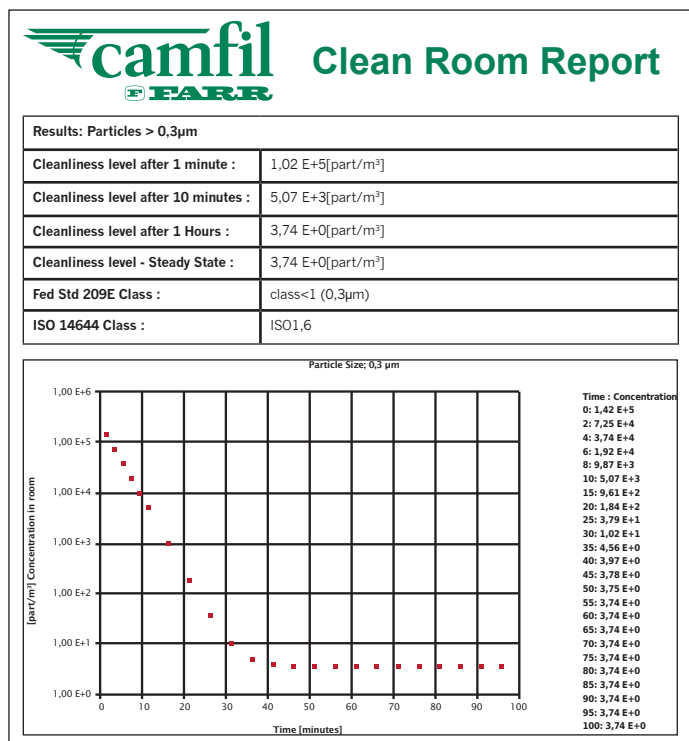

Typical air filtration design for a multi-product pharmaceutical manufacturing facility.

Life Sciences Industry Standards

Clean rooms

Today a clean room should be classified according to ISO standards or similar applicable standards. The cleanliness level is often described as a certain accumulative concentration of a specified particle size. Typically 0.1, 0.3 and 0.5 µm is used. The latest ISO DIS 14644-1 2010 was in review at the time of writing, the major proposed change is the elimination of the max concentration limit of 29 particles at 0.5 micron in an ISO 5 space.

In addition to the above proposed change, the ISO Technical Committee 209 has been working on the airborne cleanliness classification standard ISO 14644-1 1999 (TABLE 2).



Table 1: The basic classification table proposed in ISO DIS 14644-1:2010.

ISO Classification Number (N)	Maximum concentration limits (particles/m)					
	0.1 µm	0.2 µm	0.3 µm	0.5 µm	1.0 µm	5.0 µm
ISO Class 1	10					
ISO Class 2	100	24	10			
ISO Class 3	1,000	237	102	35		
ISO Class 4	10,000	2,370	1,020	352	83	
ISO Class 5	100,000	23,700	10,200	3,520	832	
ISO Class 6	1,000,000	237,000	102,000	35,200	8,320	298
ISO Class 7				352,000	83,200	2,930
ISO Class 8				3,520,000	832,000	29,300
ISO Class 9				35,200,000	8,320,000	293,000

It is expected the revised standard (s) will be published towards the end of 2012.

The intent of the revision will focus on the following:

- Simplify the classification process, and if possible remove the need to evaluate the 95% UCL (Upper Confidence Limit) for 2-9 sample locations.
- Review the classification procedure and make it more applicable to rooms in operation.
- Generally update the standards in line with current best industry practices.
- Avoid if possible any radical changes to the ISO 14644 1-9 current classification.

Proposed table for determining the number of sample locations in ISO DIS 14644-1:2012

Area (m ²) Less than or equal to	Minimum Number of Sample Locations	Area (m ²) Less than or equal to	Minimum Number of Sample Locations	Area (m ²) Less than or equal to	Minimum Number of Sample Locations
2	1	36	9	108	17
4	2	52	10	116	18
6	3	56	11	148	19
8	4	64	12	156	20
10	5	68	13	192	21
24	6	72	14	232	22
28	7	76	15	276	23
32	8	104	16	352	24
				436	25
				500	26

Some of us are still guilty of using the 'old terminology' when it comes to cleanroom standards originally developed from the US Federal standard. Below is a summary of the old standards and a quick guide to historic cleanroom air change rate calculations which to be frank in today's energy

conscious world seems grossly overestimated, CREO can help support this argument along with multiple end user case studies that can be found in more and more publications and industry guidelines, specifically ISPE COP's.

Figure 5: Historic guideline of 'typical' A/C rate recommendations used in Cleanrooms.

A/C rate reductions rightly so are being challenged today to take advantage of significant energy saving opportunities.

Basic Guide to Clean Room Design						
Classes (Fed 209 D)	1	10	100	1,000	10,000	100,000
Particles per m ³ > 0.5 micron	35.3	353	3,530	35,300	353,000	3,530,000
Air Changes Per Hour	600	500	500	40-120	20-40	10-20
Room Pressure	15 Pa	15 Pa	15 Pa	10-15 Pa	10-15 Pa	5-10 Pa
Clean air inlets Cover as % of ceiling area	100%	100%	90%	20-50%	10-20%	5-10%
Clean air inlets Locations	Ceiling					Ceiling/High Wall
Filter Location	Ceiling					Ceiling/AHU
Return Locations	Floor	Low Level or Floor		Low Sidewall	Sidewall	
Velocity at clean air inlets (m/s)	0.45			0.15-0.45		
Velocity at return air (m/s)	n/a			0.5-1	1-2.5	2.5
Airlock (required)	Yes					None
Area per occupant (m ²)	40	30	20	10	5	
Equipment in room	Minimum				30% Floor	50% Floor
Room Height	n/a		Minimum 3	Minimum 2.75	Minimum 2.25	

Comparison of Major Cleanroom Standards						
US 209 E 1992	M1.5	M2.5	M3.5	M4.5	M5.5	M6.5
ISO Class 14644-1 1999	3	4	5	6	7	8
EEC GGMP 1989	N/A		A & B	N/A	C	D
France AFNOR 1981	N/A		4000	N/A	400,000	4,000,000
Germany VDI 2083 1990	1	2	3	4	5	6
Britain BS 5295 1989	N/A		E or F	G or H	J	K
Japan JACA 1989	3	4	5	6	7	N/A

International Guideline Documents for Life Sciences		
Publisher	Description	Reference Document
ISPE	International Society Pharmaceutical Engineering	HVAC Guidelines
WHO	WHO Expert Committee for Pharmaceutical Preparations	TRS-961
ASHP	Pharmaceutical Compounding-Sterile Preparations	USP-797
US DOH	USA Department of Health	CGMP
Eurovent		4 10
IEST	Institute Environmental Sciences	IEST-RP-CC001, 007, 021, 034
ASHRAE	American Society Heating, Refrigeration, A/C Engineers	Standard 52.2 - filter testing, Guideline 26 In-Situ testing, Standard 180 HVAC Equipment Maintenance, Standard 170 Hospitals
ISO	International Standards Organization	Published: 14644, 29463 HEPA and ULPA Filtration. Coming standards underway: 16890 Filter Testing, 12249 Filtration Life Cycle Assessment, 29462 In Situ Testing
PICS	Pharmaceutical Inspection Convention	GMP Guide
EN 1822	European Norm for Classification & Testing of HEPA/ULPA Filters	EN-1822 Parts 1-5
EN779	European Norm for Pre filtration testing	EN-779 2012

There are many guideline materials we as filter manufacturers often refer to on an International basis utilized in the Life Sciences Industry. The chart to the left shows a sample of documents that can be found searching the publishers websites; a good source of information.

EU GGMP

The most recent set of standards for use in Europe came into operation on the 1st of January 1997. This is contained in a 'Revision of the Annex to the EU Guide to Good Manufacturing Practice-Manufacture of Sterile Medicinal Products'. The following is an extract of the information in the standard that is relevant to the design of clean rooms: For the manufacture of sterile medicinal products four grades are given. The airborne particulate classification for these grades is noted to the below.



Grade	Maximum Permitted Number of Particles per Cubic Meter (equal to or above)			
	At Rest ^b		In Operation	
	0.5 µm	5 µm	0.5 µm	5.0 µm
A	3,500	0	3,500	0
B ^a	3,500	0	350,000	2,000
C ^a	350,000	2,000	3,500,000	20,000
D ^a	3,500,000	20,000	Not defined ^c	Not defined ^c

(a) In order to reach the B, C and D air grades, the number of air changes should be related to the size of the room and the equipment and personnel present in the room. The air system should be provided with appropriate filters such as HEPA for grades A, B and C.

(b) The guidance given for the maximum permitted number of particles in the "at rest" condition corresponds approximately to the US Federal Standard 209E and the ISO classifications as follows: grades A and B correspond with class 100, M 3.5, ISO 5; grade C with class 10 000, M 5.5, ISO 7 and grade D with class 100 000, M 6.5, ISO 8.

(c) The requirement and limit for this area will depend on the nature of the operations carried out.

The particulate conditions given in the table for the "at rest" state should be achieved in the unmanned state after a short "clean up" period of 15-20 minutes (guidance value), after completion of operations. The particulate conditions for grade A in operation given in the table should be maintained in the zone immediately surrounding the product whenever the product or open container is exposed to the environment. It is accepted that it may not always be possible to demonstrate conformity with particulate standards at the point of fill when filling is in progress, due to the generation of particles or droplets from the product itself.

Examples of operations to be carried out in the various grades are seen below:

Grade	Examples of operations for terminally sterilized products. (see par. 11)
A	Filling of products, when unusually at risk.
C	Preparation of solutions, when unusually at risk. Filling of products.
D	Preparation of solutions and components for subsequent filling.
Grade	Examples of operations for aseptic preparations. (see par. 12)
A	Aseptic preparation and filling.
C	Preparation of solutions to be filtered..
D	Handling of components after washing.



Additional microbiological monitoring is also required outside production operations, e.g. after validation of systems, cleaning and sanitization.

Grade	Recommended limits for microbial contamination ^a			
	Air Sample (cfu/m ³)	Settle Plates (diameter 90 mm) (cfu/ 4 hours) ^b	Contact Plates (diameter 0.55 mm) (cfu/plate)	Glove Print (0.5 fingers.cfu/ glove)
A	< 1	< 1	< 1	< 1
B	10	5	5	5
C	100	50	25	--
D	200	100	50	--

Notes:

^a These are average values.

^b Individual settle plates may be exposed for less than 4 hours.

Outdoor particle concentrations (supply air)

Air conditioning systems are dependent of a supply air for keeping a room at a pressure differential with the ambient areas. This air is often supplied directly from the outdoor environment and it is important to know the contamination level of this air. In real life this concentration often varies a great deal with place and time. The table below gives estimations of particle concentrations in different environments. The values in this table can obviously vary significantly and are general estimations ranging

from very clean air (rural) to very dusty environment (industrial area). It is clear that in real life conditions an environment that could be labeled as “country town” could locally have very high concentrations depending on the activities and conditions at that site and time. The reverse may also be true, although less common. For the sake of calculation and ‘worse case’ condition, we recommend you select worst case scenario, i.e. Industrial area. The resulting calculation will mainly influence clean up time or when you reach steady state condition.

Concentration (particles per cubic meter)					
Size	Rural Area	Country Town (ODA1)	Large Town (ODA2)	Industrial Town (ODA3)	Industrial Area
≥ 0.1	5.0 • 10 ⁸	5.3• 10 ⁹	1.0• 10 ¹⁰	2.3• 10 ¹⁰	8.0• 10 ¹⁰
≥ 0.3	2.0• 10 ⁷	1.6• 10 ⁸	3.0• 10 ⁸	6.9• 10 ⁸	3.0• 10 ⁹
≥ 0.5	1.0• 10 ⁶	1.6• 10 ⁷	3.0• 10 ⁷	6.8• 10 ⁷	3.0• 10 ⁸

Internal particle generation

At the design stage of constructing a clean room one of the most difficult tasks is to estimate the internal dust generation and the influence of the cleanliness level. The human presence in clean rooms is normally one dominating factor but the process operation may also contribute significantly to particle and molecular generation.

Tests with particle counters shows that a human being wearing working clothes and engaged in extreme movement can generate up to 10⁶ particles larger than 0,1 μm per second. How much is generated in a clean room is obviously dependent on the number of people, type of clothes, the activity and the type of work conducted. To determine the exact value is difficult but by using general estimations it is possible to get a good indication of how the humans may affect the cleanliness in a room in operation compared to the “at rest” state. By selecting the suitable type of clean room garment the dust generation from humans could be reduced from 10 to 100 times.

In the CREO software the levels of human dust generation is defined according to the “Helmke Drum Test” (IEST – RP – CC003.3)^a for Class I, II and III. Table 4 shows the particle generation for each garment selection. In the analysis the particle generation of class I, II and III is determined only by the user selection of clothes^b regardless of activity. “Clean room clothes”, “normal clothes” and “heavy working” represents higher level of particles release due to clothing and some activity. However, these values are under real conditions dependent on the individual and therefore the values should be regarded only as a general guideline. When accurate data (measured) on particle generation in the clean room is available, it is suggested to use the manual input option for particle generation (“Particles from the process”). This input can then be used as a representative value of the total generation inside the clean room, including machinery, humans and operation activities.

Class	Garment	Particles ≥ 0.3 μm (particles/min.)	Particles ≥ 0,5 μm (particles/min.)
Class I	Frock	< 1,700	< 1,000
	Coverall	< 2,000	< 1,200
Class II	Frock	1,700 - 17,000	1,000 - 10,000
	Coverall	2,000 - 20,000	1,200 - 12,000
Class III	Frock	17,000 - 170,000	10,000 - 100,000
	Coverall	20,000 - 200,000	12,000 - 120,000

Particle size (μm)	Class I	Class II	Class III	Clean Room Clothes	Normal Clothes	Hard Working
≥ 0.1	83	833	8,330	50,000	100,000	1,000,000
≥ 0.3	33	333	3,330	20,000	80,000	400,000
≥ 0.5	20	200	2,000	10,000	50,000	200,000

^a IEST-RP-CC003.3 The test simulates particle shedding of clothing under movement. During the Helmke drum test, the garment is tumbled in a rotating drum to release particles from the surface of the cleanroom garment in a controlled manner. An automatic particle counter is used to sample the air within the drum to determine the average particle concentration of the air during the initial ten minutes of the test.

^b Coveralls

Startup concentration (CO)

The initial conditions for the calculation can vary depending on what activity has been taken place in the room. For instance the initial concentration (CO) may be close to zero after a night with no activities in the clean room. On the other hand it could be very high due to a stop in production or a service interval (filter replacement etc.). Typically the steady state concentrations will be achieved between 10 and 60 minutes of normal operation.

Air filters

Air filters play a very important role in clean room environments with demands on high cleanliness. Although the filter is a component in a complex system, it is essential to have the right type of filters installed to ensure that the background levels of particle and molecular contaminants are at low level. It is not only the efficiency of the filter that is important to address, but also the energy consumption (the pressure drop during the entire operation). This is essential to take in account when designing sustainable air handling system solutions. Never the less there are other significant things apart from the filter that affect the cleanliness of the system. The raw materials and its handling, the protection of the product in the process and the ventilation system design are all very important parameters. The most crucial to control is often the contaminants generated by people and machinery inside the clean room. The table below shows measured particle generation from people depending on their activity level.

Filters are used in different places in a ventilation system. Depending on the design of the system such as the amount of supply air, air intake and filter position and how the exhaust air is treated the air

Particle size (µm)	High Level of Generation	Walking With Standard Garment	Carefully Walking With Standard Garment
≥ 0.1	1•10 ⁶	5•10 ⁴	5•10 ³
≥ 0.3	4•10 ⁵	2•10 ⁴	2•10 ³
≥ 0.5	2•10 ⁵	1•10 ⁴	1•10 ³



cleanliness can be quite different. The choice of filter should be made in consideration to this. Typically the main consideration when selecting an air filter is the efficiency at different particle sizes. For 0.1 µm particles for instance, the efficiency can vary from 10% for a M6 (MERV 11) filter up to 99,99995 for a U17 (ISO 75E) filter. It is also important to realize that a filter does not have the same efficiency for all particle sizes. A particulate air filter has for each particle size a specific efficiency depending on the filter material, construction and velocity. Test aerosols generated 'hot or cold' can influence the result of the efficiency measured locally, more detailed explanations can be found on this subject by contacting Camfil.

H14 according to EN 1822 is the recommended filter grade for use in Pharmaceutical cleanrooms. ISO have recently published a new standard 24963, the equivalent to H14 would be ISO 45E, IEST grade



would be type K. For further detailed information you can source multiple technical publications published by Camfil and other organizations. ISO 29463, EN 1822 and IEST-RP-CC001 & are shown below:

ISO 29463 classifications

Filter Class (Group)	Particle Size for Testing	Global Values		Local/Leak Values		
		Collection Efficiency (%)	Penetration (%)	Collection Efficiency (%)	Penetration (%)	Multiple of Global Efficiency (%)
ISO 15 E	MPPS	≥95	≤5	-	-	-
ISO 20 E	MPPS	≥99	≤1	-	-	-
ISO 25 E	MPPS	≥99.5	≤0.5	-	-	-
ISO 30 E	MPPS	≥99.9	≤0.1	-	-	-
ISO 35 E	MPPS	≥99.95	≤0.05	≥99.75	≤0.25	5
ISO 40 E	MPPS	≥99.99	≤0.01	≥99.5	≤0.5	5
ISO 45 E	MPPS	≥99.995	≤0.005	≥99.975	≤0.025	5
ISO 50 E	MPPS	≥99.999	≤0.001	≥99.995	≤0.005	5
ISO 55 E	MPPS	≥99.9995	≤0.0005	≥99.9975	≤0.0025	5
ISO 60 E	MPPS	≥99.9999	≤0.0001	≥99.9995	≤0.0005	5
ISO 65 E	MPPS	≥99.99995	≤0.00005	≥99.99975	≤0.00025	5
ISO 70 E	MPPS	≥99.99999	≤0.00001	≥99.9999	≤0.0001	10
ISO 75 E	MPPS	≥99.999995	≤0.000005	≥99.9999	≤0.0001	20

ISO 29463-1:2011 establishes a classification of filters based on their performance, as determined in accordance with ISO 29463-3, ISO 29463-4 and ISO 29463-5. It also provides an overview of the test procedures, and specifies general requirements for assessing and marking the filters, as well as for documenting the test results. It is intended for use in conjunction with ISO 29463 2, ISO 29463 3, ISO 29463-4 and ISO 29463-5.

EN1822 Classifications

Filter Class	Particle Size for Testing	Global Values		Local Leak Values		
		Collection Efficiency (%)	Penetration (%)	Collection Efficiency (%)	Penetration (%)	Multiple of Global Efficiency (%)
E10		≥ 85	≤ 15			
E11		≥ 95	≤ 5			
E12		≥ 99.5	≤ 0.5			
H13	MPPS ^a	≥ 99.95	≤ 0.05	≥ 99.75	≤ 0.25	5
H14	MPPS ^a	≥ 99.995	≤ 0.005	≥ 99.975	≤ 0.025	5
U15	MPPS ^a	≥ 99.9995	≤ 0.0005	≥ 99.9975	≤ 0.0025	5
U16	MPPS ^a	≥ 99.99995	≤ 0.00005	≥ 99.99975	≤ 0.00025	5
U17	MPPS ^a	≥ 99.999995	≤ 0.000005	≥ 99.9999	≤ 0.0001	20

^a MPPS - Most Penetrating Particle Size

EN-1822

This European standard is based on particle counting methods that actually cover most needs for different applications. EN 1822:2009 differs from its previous edition (EN 1822:1998) by including the following:

An alternative method for leakage testing of Group H filters with shapes other than panels

An alternative test method for using a solid, instead of a liquid, test aerosol

A method for testing and classifying of filters made out of membrane-type media

A method for testing and classifying filters made out of synthetic fiber media

The main difference is related to the classification for the filter classes H10 · H12, which has now been changed to E10 · E12.

IEST-RP-CC001

Filter Type	Particle Size for Testing	Global Values		Local Leak Values		
		Collection Efficiency (%)	Penetration (%)	Collection Efficiency (%)	Penetration (%)	Multiple of Global Efficiency (%)
A	0.3 ^a	≥ 99.97	≤ 0.03			
B	0.3 ^a	≥ 99.97	≤ 0.03	Two-Flow Leak Test		
E	0.3 ^a	≥ 99.97	≤ 0.03	Two-Flow Leak Test		
H	0.1-0.2 or 0.2-0.3 ^b	≥ 99.97	≤ 0.03			
I	0.1-0.2 or 0.2-0.3 ^b	≥ 99.97	≤ 0.03	Two-Flow Leak Test		
C	0.3 ^a	≥ 99.99	≤ 0.01	≥ 99.99	≤ 0.01	1
J	0.1-0.2 or 0.2-0.3 ^b	≥ 99.99	≤ 0.01	≥ 99.99	≤ 0.01	1
K	0.1-0.2 or 0.2-0.3 ^b	≥ 99.995	≤ 0.005	≥ 99.992	≤ 0.008	1.6
D	0.3 ^a	≥ 99.999	≤ 0.001	≥ 99.99	≤ 0.005	5
F	0.1-0.2 or 0.2-0.3 ^b	≥ 99.9995	≤ 0.0005	≥ 99.995	≤ 0.0025	5
G	0.1-0.2	≥ 99.9999	≤ 0.0001	≥ 99.999	≤ 0.001	10

^a Mass median diameter particles (or with a count median diameter typically smaller than 0.2 µm as noted above).

^b Use the particle size range that yields the lowest efficiency.

IEST -RP-CC-001

This Recommended Practice (RP), IEST-RP-CC001.5, covers basic provisions for HEPA (high efficiency particulate air) and ULPA (ultra-low penetration air) filter units as a basis for agreement between customers and suppliers.

HEPA filters and ULPA filters that meet the requirements of this RP are suitable for use in clean air devices and cleanrooms that fall within the scope of ISO 14644 and for use in supply air and contaminated exhaust systems that require extremely high filter efficiency (99.97% or higher) for sub micrometer (µm) particles.

This RP describes 11 levels of filter performance and six grades of filter construction. The customer's purchase order should specify the level of performance and grade of construction required. The customer should also specify the filter efficiency required if it is not covered by the performance levels specified in this RP.

HVAC Air Filter Standards

The filtration industry is inundated with multiple filtration standards to classify, identify, and evaluate various performance characteristics of an air filter. In the USA, the organization known as ASHRAE (American Society of Heating, Refrigerating, and Air-Conditioning Engineers) was founded in 1894 and is currently an international organization of 50,000 persons.

ASHRAE has published a laboratory filtration performance standard for testing air filters since 1968 and all have been accredited by the American National Standards Institute (ANSI) to define minimum values or acceptable performance.

In Europe, the history of the filtration standards mimics the ASHRAE standard path. The European Committee for Standardization (CEN) formalized their filtration standard in 1993 with the publication of EN-779:1993. This document was very similar to ASHRAE 52.1-1992 and with only minor differences, used the same equipment and test method of the ASHRAE standard. In 2002 CEN followed the ASHRAE lead by revising EN-779 into a particle removal efficiency standard similar to ASHRAE 52.2. However, this new document EN-779:2002 had some striking differences, both good and bad.

In 2002 CEN released the 2002 version of the European EN-779 standard. As with the 1999

revision to the ASHRAE document, this new procedure converted from Dust Spot efficiency to a particle removal test method. The actual test method and equipment used is different between the two standards in a number of ways with the most important variations listed below:

Particle size range measured – Since 99% of all the particulate found in atmospheric air is below 1.0 micron it is important to know the filtration performance below that point. ASHRAE went with a higher upper limit to be able to provide particle removal efficiency for lower end pre-filters.

- ASHRAE 52.2 – 0.3 micron to 10.0 microns , EN-779 – 0.2 micron - 3.0 microns
- ASHRAE 52.2 challenges the filter with a solid phase KCl aerosol (Potassium Chloride), EN-779 challenges the filter with a liquid phase DEHS aerosol (Di-2- ethylhexyl sebacate)
- ASHRAE 52.2 uses the minimum efficiency curve at all 12 particle size ranges from each of the loading steps, EN-779 uses the average efficiency at 0.4 microns, but this value is still based on loading with ASHRAE dust.
- Conditioning vs. Discharging – Filters made with a media that has an electrostatic charge can show results, when tested per either standard, that are higher than how that filter will perform in an AHU.
- EN-779:2002 took a very positive approach in requiring the use of Annex A. This Annex required the media from the filter be subjected to a discharging method such as an Isopropanol (IPA) dip and then tested for particle removal efficiency. This data would show the user if the media was charged and if so, how far it might drop in efficiency when installed in service.

Air Filters Testing Standards Comparison											
ASHRAE Standard 52.2-2007B				ASHRAE 52.1-1992		EN 779 2002	EN 779 2012				
Minimum Efficiency Reporting Value	Composite Average Particle Size Efficiency, % in Size Range, microns			Average Arrestance	Average Dust Spot Efficiency	Class	Average Efficiency at 0.4 micron ¹	Group	Class		
	Range 1	Range 2	Range 3								
MERV	0.30 - 1.0	1.0 - 3.0	3.0 - 10.0	%	%		%				
1	n/a	n/a	E ₃ < 20	A _{avg} ≥ 65	< 20	G1	A<65	Coarse	G1		
2	n/a	n/a	E ₃ < 20	A _{avg} ≥ 65	< 20	G2	65< A ≤80		G2		
3	n/a	n/a	E ₃ < 20	A _{avg} ≥ 70	< 20				G3	80< A ≤90	G3
4	n/a	n/a	E ₃ < 20	A _{avg} ≥ 75	< 20	G4	90< A				G4
5	n/a	n/a	E ₃ ≥ 20	80	20						F5
6	n/a	n/a	E ₃ ≥ 35	85	20-25	F6	0< E ≤80		M6		
7	n/a	n/a	E ₃ ≥ 50	90	25-30					F7	F7 80< E ≤90
8	n/a	n/a	E ₃ ≥ 70	92	30-35	F8	F8 90< E ≤95	F8			
9	n/a	n/a	E ₃ ≥ 85	95	40-45				F9	F9 95< E	F9
10	n/a	E ₂ ≥ 50	E ₃ ≥ 85	96	50-55	NA	H10	NA			
11	n/a	E ₂ ≥ 65	E ₃ ≥ 85	97	60-65				NA	H10	NA
12	n/a	E ₂ ≥ 80	E ₃ ≥ 90	98	70-75	NA	H10	NA			
13	n/a	E ₂ ≥ 90	E ₃ ≥ 90	98	80-85				NA	H10	NA
14	E ₁ ≥ 75	E ₂ ≥ 90	E ₃ ≥ 90	99	90-95	NA	H10	NA			
15	E ₁ ≥ 85	E ₂ ≥ 90	E ₃ ≥ 90	99	95				NA	H10	NA
16	E ₁ ≥ 95	E ₂ ≥ 95	E ₃ ≥ 95	100	99	NA	H10	NA			

Notes:
 The final MERV value is the highest MERV where the filter data meets all requirements of that MERV.
 The characteristics of atmospheric dust vary widely in comparison with those of synthetic dust used in the tests. Because of this the test results do not provide a basis for predicting either operational performance or life. Loss of media charge or shedding of particles or fibers can also adversely affect efficiency.
¹ Minimum efficiency is the lowest efficiency among the initial efficiencies, discharged efficiency and the lowest efficiency throughout the test procedure.

Summary

As most of you know, standards sometimes change no sooner than we start to get used to them, some of us still use Fed Standard 209D (Class 100, 10,000 etc) The ISO terminology starts to be the common language on a global basis even though some countries/regions still have their local standards.

Most of us involved in the Life Science industry can all quote EU GMP Grade A/ISO 14644 Class 5/FDA cGMP1 Class 100 cleanroom has been with us long before EU GMP Annex 12 changed to mandate the 1m3 sample size.

Both EU GMP and the FDA cGMP1 set the target

levels of contamination for the different grades of cleanrooms. Both then indicate that the correct method of determining these contamination levels is to be found in ISO 14644.

As mentioned earlier, while EU GMP and FDA cGMP1 state the target cleanliness levels for cleanrooms, they both refer the reader to ISO 14644 for the methods to determine these cleanliness levels. The Standard Operating Procedures (SOP) used by pharmaceutical QC teams in their environmental monitoring to determine the cleanroom cleanliness will have been written around not only the limits defined in EU GMP and the FDA's cGMP1 documents but also around the methods laid down in ISO 14644.

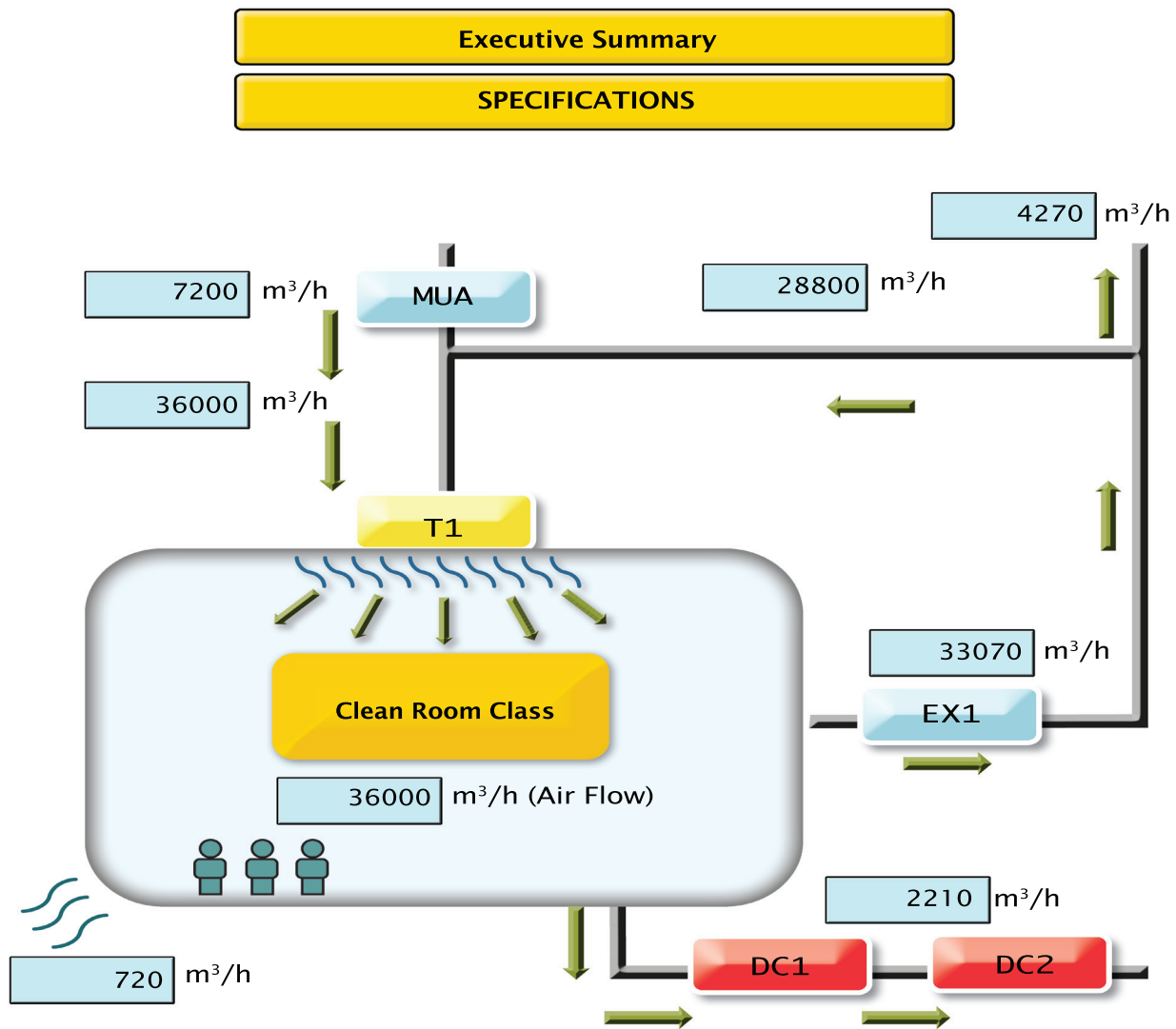

CREO Executive Summary output from software.

Clean Room Design Standards & Energy Optimization References:

1. Food and Drug Administration. Guidance for industry. Sterile drug products produced by aseptic processing—current good manufacturing practice, 2004. U.S. Department of Health and Human Services Food and Drug Administration Center for Drug Evaluation and Research (CDER) Center for Biologics Evaluation and Research (CBER) Office of Regulatory affairs (ORA) Division of Drug Information, HFD-240 Center for Drug Evaluation and Research Food and Drug Administration, 5600 Fishers Lane, Rockville, MD 20857 USA.
2. Cleanroom Filters a Guide. Published by Camfil ab.
3. European Commission. Ad Hoc GMP Inspections Services Group. EC Guide to Good Manufacturing Practice. Revision to Annex 1. Manufacture of Sterile Medicinal Products, May 30, 2003.
4. ISO 14644-1:1999(E) Cleanrooms and associated controlled environments—Part 1: Classification of air cleanliness May 1, 1999. International Organization for Standardization Case Postale 56, CH-1211 Genève 20, Switzerland.
5. Life Science Industry Insights. Published by Camfil USA Inc.

Setting the Standard for Air Quality and Filter Technology



Camfil Farr Road Show

The Camfil Farr Road Show, based in Europe, allows visitors to review the latest air quality and air filter technology. In-place testing equipment demonstrates air filter performance under local air quality conditions.

Promoted to local politicians, manufacturers and customers, it advocates clean air as a human right.



World's Most Advanced Testing Laboratory

Camfil Farr's corporate laboratory in Trosa, Sweden offers air filter evaluation beyond any level presented anywhere including universities and other filter manufacturers. Long a leader in particulate filter evaluation for commercial and HEPA grade filters, Camfil Farr has added the most extensive gaseous testing laboratory in the world.

Mobile Filter Testing Laboratories

Our mobile lab has been used at multiple pharmaceutical facilities in the USA & Europe to validate our LCC/TCO projections. The mobile lab measures filter efficiency, pressure drop, temperature, humidity and filter related energy consumption all through cell phone technology and without disrupting the site facilities, and most importantly giving a true representation of how Camfil Farr (and competitor's filters) perform in your environment!



CREO

CAMFIL FARR is the world's largest and leading manufacturer of air filters and clean air solutions

There is a good chance that, at this very moment, you are breathing clean air that has passed through an air filter manufactured by us. Our products can be found everywhere from offices to clean rooms for sensitive electronics production, mines, factories, hospitals and nuclear power stations. Camfil Farr is a global company with 29 subsidiaries, 23 production plants and an extensive network of agents in Europe, North America and Asia.

www.camfilfarr.com

For further information please contact your nearest Camfil Farr office.