

# **Clear-Com**

**Intercom Systems**

INSTRUCTION  
and  
SERVICE MANUAL

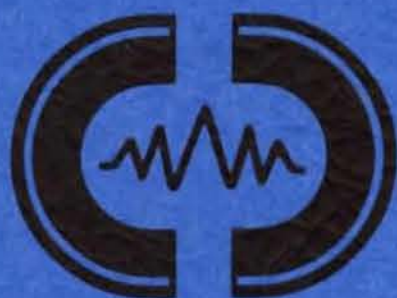

**759 Harrison Street San Francisco, Ca. 94107 • (415) 989-1130**

# CLEAR-COM INSTRUCTION MANUAL

## INTRODUCTION

### 1.1 GENERAL

The Clear-Com system is a closed circuit intercommunication system designed for clear- two-way communication in high noise environments. Low impedance lines (200 ohms) and specially designed circuitry make the system virtually immune to RF and dimmer noise. The basic system consists of a main station and from one to 40 remote stations, joined by inter-connecting cable. Main stations are available in portable cases (single channel CS-100 and dual-channel CS-200), as well as rack-mountable enclosures (CS-100K and CS-200K). There are several interchangeable remote stations: the RS-100A "belt pack", the KB-100 "King Biscuit" mic/speaker unit, the MR-102 wall-mount unit, the KB-111 wall mount unit with speaker, and the KB-111P portable remote unit with speaker. The master gain control, located on the main station rear panel, allows the operator to set the overall gain in accordance with the number of remote stations being used.

All remote stations, except the MR-102, have adjustable side tone which enables the user to vary the amount of his or her own voice in the headset, handset or speaker for maximum intelligibility with minimum chance of feedback. All remote stations have their own volume control for adjusting the level in the earpiece (s), call switches and call lights for signaling from other stations.

Clear-Com is a distributed amplifier system, with each remote station housing its own mic preamplifier and headset power amplifier (+20dBm max output). The main station supplies 28V dc necessary for operating all circuits, and power is carried to remote stations via the same interconnecting cable which carries the audio signals. The main stations also have an auxiliary, line-level input with its own volume control which allows mixing of an external program with the intercom line. This is useful for program monitoring.

A power-supply only main station is available, the model PS-3000. Standard microphone cables (XLR-3 type connectors) are used for inter-connection in most cases; the WP-1 and WP-2 wall-mount connector plates may be used in some permanent installations. Interconnect cables, and a 4-way splitter (the Quadropuss) are available from Clear-Com.

SECTION II  
INSTALLATION

2.1 EQUIPMENT SELECTION

2.1.1 FIXED SYSTEM MAIN STATIONS

For permanent intercom systems, main station equipment is usually mounted in a standard 19" rack for security and convenience. For this reason, we recommend either the CS-100K single-channel main station or the CS-200K dual-channel main station. However, if an intercom station is not needed at the area where the equipment rack is located, then the PS-3000 power supply (without intercom station) should be substituted.

2.1.2 FIXED SYSTEM REMOTE STATIONS

In permanent installations, it is usually desirable to run interconnecting cables through conduits, and to bring them to wall-mounted remote stations, or to wall plates for connection to portable remote stations. We recommend the MR-102 wall-mount remote station, or the KB-111 wall mount remote station with paging speaker. If you don't wish to have the remote station built into the wall, then use our WP-1 or WP-2 wall plates with any of our portable remote stations; the RS-100A "belt pack", the KB-100 "King Biscuit" mic/speaker station, or the KB-111P headset/handset station with paging speaker.

2.1.3 PORTABLE SYSTEM MAIN STATIONS

For portable intercom systems, main station equipment must be compact, lightweight, and easily moved for storage. The CS-100 single-channel main station and CS-200 dual-channel main station fulfill these requirements.

2.1.4 PORTABLE SYSTEM REMOTE STATIONS

The RS-100A "belt pack" is the key to our truly flexible portable intercom system. Because each RS-100A has a pair of input and extension connectors, many stations may be "daisy chained" together along one interconnect path. This saves cable and simplifies installation and break down.

The KB-100 "King Biscuit" mic/speaker remote station is ideal for use in remote trucks and in studio control rooms, as well as on stage during setup of live shows. It can be used either in push-to-talk mode, or in an optional "hands-free" mode where the speaker and microphone both function simultaneously. In the latter mode, 2-way communication is possible at distances up to three or four feet, depending on ambient noise levels.

### 2.1.5. CLEAR-COM HEADSETS AND HANDSETS

Clear-Com has three standard headsets available, all with boom-mounted, noise-cancelling microphones. The CC-240 is a double-muff headset, and the CC-75 is a single-muff headset, both with boom-activated mics. The PH-7 is a double muff headset which has wider frequency response, greater isolation from ambient noise, and sturdier physical construction than the CC-240, and no mic switch in the boom. All units have field-replaceable cords. The HS-6 telephone-style handset is interchangeable with the above headsets.

All remote stations can drive 2 headsets with only a slight reduction in level. A Y-cord can be made up using the diagram below and the specified wire. Extension cords for the headset can also be made out of this same cable or other separately shielded cable such as Belden 8734, 8416 or 9454. Extensions should be limited to approximately 15' due to the possibility of capacity coupling between the microphone signal and the headset signal which would cause a loss of high frequency response or oscillation.

CAUTION: DO NOT connect microphone ground and earphone ground together at any point.

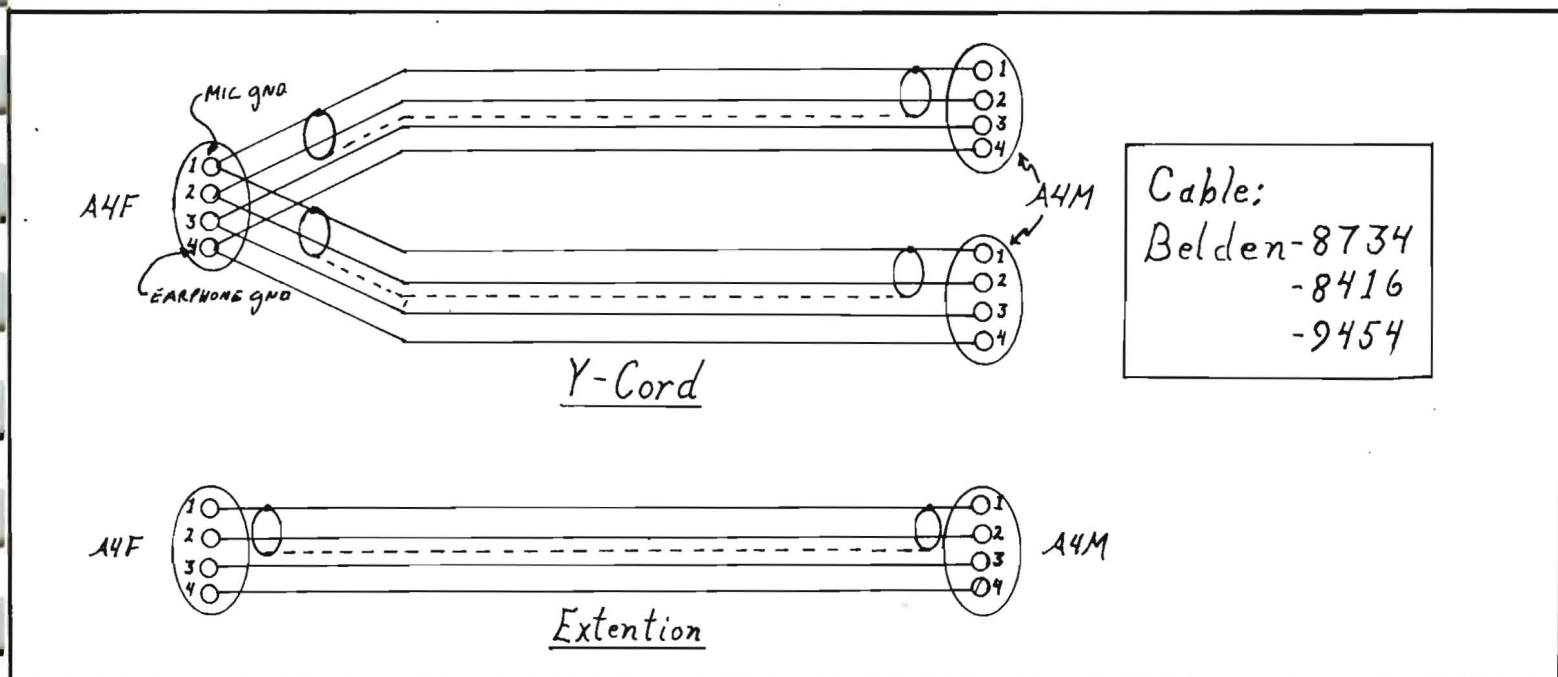

### 2.1.6. OTHER HEADSETS

Non-Clear-Com headsets are available from Clear-Com or local dealers. These are recommended for special applications:

- |              |   |
|--------------|---|
| Beyer DT-108 | Single-muff, high-fidelity earpiece with boom mic; may be used for monitoring and intercom. |
| Shure SM-12  | Miniature, lightweight type with boom mic and hearing-aid type earpiece.                    |

## 2.1.6 INTERFACE TO OTHER COMMUNICATION SYSTEMS

The AC-10 Adapt-a-Com is a universal adapter which enables Clear-Com to be interfaced with any other intercom or communications link. When existing non-Clear-Com installations are being upgraded to Clear-Com equipment, portions of the older system can be retained. Since Adapt-a-Com works in 2-, 3- and 4-wire systems, it virtually guarantees compatibility with any house intercom equipment.

Because it will simulate a carbon mic, Adapt-a-Com can be plugged into the headset jack on a TV camera, control unit, or other 2-wire systems. Adapt-a-Com operates with telephone company and competitive model 3-wire intercoms, facilitates on-line intercom via standard telephone systems, and aids in direct communication between the studio and remote locations via 2 or 4 wire dedicated TEL.CO. pairs.

## 2.1.7 AUDIO ISOLATION OF PARTS OF THE INTERCOM SYSTEM

In certain applications, it may be desirable to isolate conversations in one section of the system. In these instances, the BA-1 in-line isolator may be used to block audio while allowing power to flow to the isolated leg of the system. This inexpensive, passive device creates a quasi-dual channel system from a single channel, except that the main station cannot contact or be called by the isolated leg of the system. The BA-1 enables you to have private local conversations along a common interconnect cable without need for multiple cabling or several main stations. Any number of BA-1's may be used, so long as the power capacity of the main station is not exceeded.

## 2.2 MAXIMUM NUMBER OF STATIONS AND CABLE CONSIDERATIONS

### 2.2.1 MAIN STATION CURRENT AND IMPEDANCE LIMITS

All Clear-Com main stations, including the PS-3000 power supply, have the same maximum output current capacity, 2 amps. For dual channel main stations, the total current draw on both channels cannot exceed 2 amps.

Due to impedance considerations, regardless of the cable lengths or mix of remote stations, 40 stations are the maximum that can be driven from one main station. (In certain circumstances, it may be possible to use more than 40 stations; contact the factory for details.)

### 2.2.2 CALCULATING THE MAXIMUM NUMBER OF REMOTE STATIONS

In installations with less than 500 feet total interconnecting cable, only the remote station current requirements need be considered. One main station will support up to 40 RS-100A or MR-102 remote stations, or up to 15 KB-100 or KB-111 remote stations.

When calculating the maximum current drain, only two figures need be considered; a maximum current drain of 40 ma in the RS-100A or MR-102, and an average current drain of 130ma in the KB-100 or KB-111. Thus, an equation for maximum stations would be as follows:

$$X = \text{Number of RS-100A's} + \text{MR-102's} \leq 40.$$

$$Y = \text{Number of KB-100's} + \text{KB-111's} \leq 15.$$

Therefore,

$$0.04X + 0.13Y \leq 2.0$$

### 2.2.3 CABLES

Where cable lengths greater than 500 feet are involved, the maximum number of remote stations, depends on four factors; the current requirements of each remote station, the length of the wire, the wire gauge, and the cable capacitance. In all instances, 2-conductor, shielded interconnecting cable should be used.

A. PORTABLE INSTALLATIONS: rubber-insulated and jacketed cable should be used due to its superior strength and durability. Belden 8413 miniature cable (24 ga. stranded conductors) is usable up to 500 feet. Belden 8412 (20 ga. stranded conductors) is usable up to 5,000 feet.

B. PERMANENT INSTALLATIONS: Vinyl-insulated and jacketed cable may be used; it costs less and is easier to pull through conduit than rubber insulated types. However, low capacitance cable must be used. Belden 8762 (20 ga. stranded conductors) is usable up to 500 feet. Belden 8760 (18 ga. stranded conductors) is usable up to 5,000 feet. NOTE: In systems where conduit is not used, and where equipment may not share a common ground, it may be necessary to run an additional ground wire to tie chassis together. This may be accomplished with Belden 8770 3-conductor shielded cable.

C. 2-CHANNEL PERMANENT INSTALLATIONS: Permanent systems can be wired in one of two ways. First, Channel A and Channel B may be routed to two distinct areas, for use by different people. Second, both channels may be routed together and brought to WP-2 wall plates so the user can select either channel A or B. The second method can be wired with two 2-conductor shielded cables or one multi-pair shielded cable.

Cables equivalent to the Belden types may be used, so long as their capacitance and wire gauge are comparable. Particularly in longer runs, it is desirable to use cable which has low resistance (large diameter conductors) and low inter-conductor capacitance.

## 2.3. LAYING OUT THE SYSTEM

### 2.3.1 PORTABLE INSTALLATIONS

Having determined the number and type of remote stations you wish to use, decide on a location for the main station. It should be near a source of 115V AC (power consumption is approximately 80 watts.) There are six parallel outputs available on the rear panel of the CS-100, and two sets of 3 parallel outputs on the CS-200. Any remote stations can be connected directly to the 6 outputs. Additionally, remote stations can be added by "daisy chaining" them to one another and/or by using the QP-100 Quadrapuss splitter. Cables should be routed away from heavy AC power sources, such as lighting panels, electric motors, etc.

### 2.3.2 PERMANENT INSTALLATIONS

The same general considerations apply here as for portable systems, as described in the preceding paragraph. Additionally, cables should be installed in accordance with approved local building codes. Class II wiring may be used. Connections to wall-plates or wall-mount remote stations are shown in the diagrams.

### 2.3.3 ISOLATED CHANNELS

The BA-1 In-Line Isolator can be installed anywhere in the system. For example, plug it into one output connector on the rear panel of the main station to create an entire isolated channel. Alternately, plug it into a remote station at the end of a cable run to isolate further remote stations while using a minimum of additional interconnect cable.

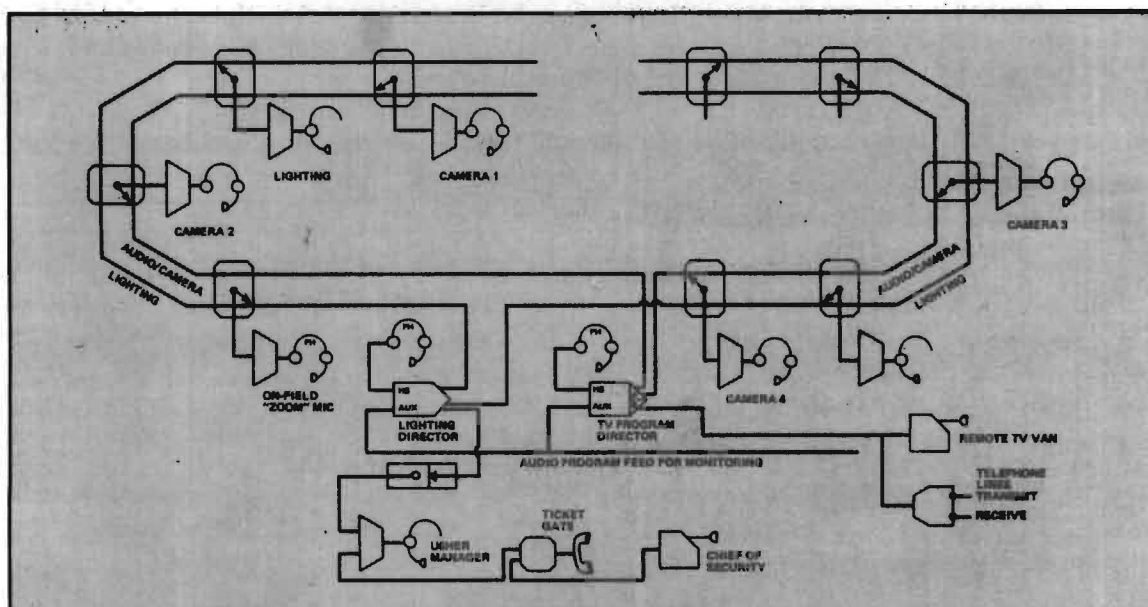

Typical Coliseum Intercom System

## OPERATION OF THE SYSTEM

OPERATION OF THE CLEAR-COM SYSTEM IS QUITE SIMPLE, AS FOLLOWS:

1. CONNECT MAIN STATION to all remote stations with interconnecting cable.  
NOTE: Before connecting rear panel interconnecting cables, shut power off and hold call button depressed until call light(s) go out.
2. PLUG IN HEADPHONES at main station and remote stations into HEADSET CONNECTORS at front panel. (To locate connectors and controls, see Figure 1.)  
Headset connectors in main station are wired in parallel. Use one or both.
3. SET MASTER GAIN SET at rear panel of main station for overall system level to compensate for number of remote stations in system. (CS-200 has one gain control for each channel.) Under high noise conditions, turn master gain DOWN and speak with microphone very close to the mouth.
4. SET HEADSET VOLUME CONTROLS at main station and remote stations for individual volume level. Volume controls are located on front panel.
5. TO SIGNAL stations where headphones may have been removed, press CALL BUTTON on front panel and CALL LIGHT will go on. Call lights light up at all stations simultaneously.
6. THE AUXILIARY INPUT CONNECTOR on front panel of the main station provides for external program feeding into the entire system. (See schematics for connecting details). The AUXILIARY VOLUME CONTROL is located directly on top of the auxiliary input connector and controls the auxiliary input volume to the system.
7. THE CS-200 MAIN STATION can communicate with two separate channels, A and B. THE CHANNEL SELECT SWITCH which is located on the front panel of the main station, can be switched to positions A, B or A + B. The A or B position enables the main station to communicate with either channel A or B, respectively, while the A + B position enables the main station to communicate with both simultaneously. Regardless of the position of the switch, remote stations on channel A can always talk to other remote stations on A, but A cannot communicate with remote stations on channel B, and vice-versa. Also, note that the call lights are always operative from main station to both channels A and B, regardless of the switch position.
8. CAUTION:
  - A) DO NOT allow belt packs to come into contact with other pieces of electrical equipment. An improper ground or short in a piece of electrical equipment touching a Clear-Com remote station can cause a hum or a buzz in the system. When connecting remote stations to electrical equipment, make sure the equipment is properly grounded.
  - B) DO NOT wear the remote stations in wet weather without ensuring that the station is properly grounded.



OPERATION OF SYSTEM  
PS-3000 INTERCOM POWER SUPPLY

DESCRIPTION

The PS-3000 is a regulated intercom power unit designed to power all Clear-Com remote stations. Typically, it can be installed in areas not requiring a headset function, i.e., isolated rack bays.

The PS-3000 supplies 30v at 2 amps and is capable of supporting a minimum of 40 Clear-Com remote stations. It is protected against shorts in the cable by current foldback in the regulator circuit and provides visual indication of such conditions on the front panel system. The unit has provisions for an auxiliary program input to the intercom system with the level adjustable from the front panel.

INSTALLATION AND OPERATION

The PS-3000 can be mounted in a standard 19" rack. Because the PS-3000 can dissipate a considerable amount of heat, it is recommended that at least an inch of space be allowed above the unit to facilitate ventilation.

All interconnections to the unit are made from the rear panel. Four parallel D3M connectors are provided for system output. As in any Clear-Com system, the lines to the remote stations may be "home-runs" or the stations may be "daisy chained." Once the system has been set up, the overall level may be adjusted with system level control.

If, at any time, short circuit conditions are encountered, the problem can usually be isolated by removing the interconnect cables from the unit, one at a time, until the short circuit indicator goes out. It may be necessary to shut the unit off for a few seconds to reset the short circuit indicator.

An internal 1-1/2 amp slow-blow fuse protects the PS-3000 in case of internal power supply failure. If the fuse repeatedly blows, it means the power transistor or a component on the p.c. board has failed. The cover is held on by "snap on" fasteners. To remove - pull cover up hard.

TROUBLE SHOOTING

<u>SYMPTOM</u>	<u>CAUSE</u>	<u>REMEDY</u>
1) System is totally dead, power switch light doesn't come on.	Circuit breaker open. A.C. power failure.	Reset circuit breaker. Check A.C. power line.
2) Circuit breaker trips repeatedly or short circuit LED remains lit (PS-3000 only)	Shorted or mis-wired inter-connect cable. Defective remote unit.	Remove cables from main station one at a time until faulty line is isolated. Check for shorts between pins 1 and 2.
3) Oscillation	Feedback caused by unused headset left with mic on and volume turned up.	Turn off mics on all unused headsets.
4) Call light doesn't work.	Bulb burned out.	Unscrew lens from lamp holder. Replace lamp with GE 327.
5) Individual Remote Station malfunction.	Faulty remote station, headset or cable.	Replace suspect unit with known good unit. Defective remote stations or headsets should be returned to factory for service. There are no user servicable parts in these units.
6) Hum or Buzz in system.	Inductive pickup caused by close proximity of main or remote station to power lines or transformers.  Ground loop caused by improper grounding of system (See installation instructions)  10-ohm chassis ground resistor (R1 CS-200) in main station open. (Note: This is caused by the system ground coming in contact with something that is "hot" with respect to main station earth ground. Should this occur, a careful check of the system ground and A.C. distribution in your location is recommended.)	Relocate offending unit.  Reverse power cord. Lift ground.  Open main station by removing 2 screws in handle and unscrewing 4 feet. Slide off cover and check 10 ohm resistor on the bridge rectifier terminal strip. If open, replace

# SYSTEM INTERCONNECTION DIAGRAM

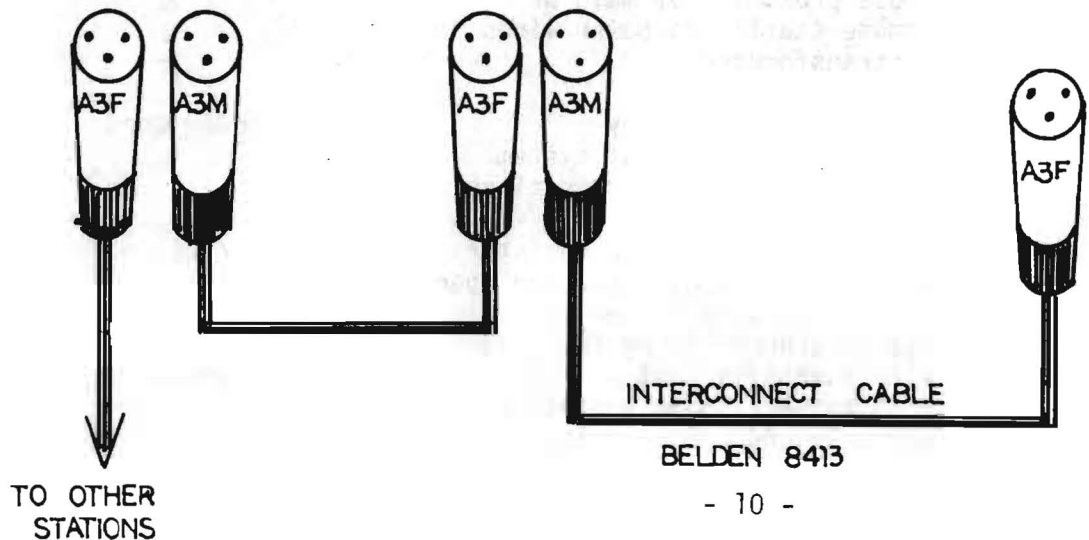
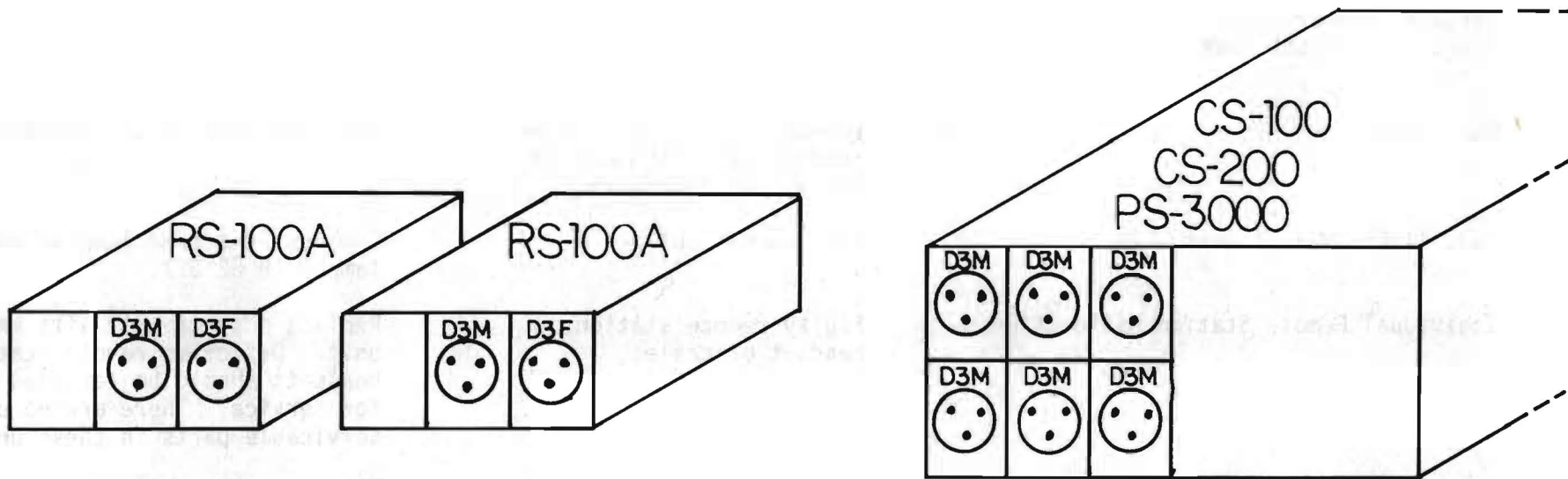

PIN CONNECTIONS  
FOR CABLE

- PIN 1 — SHIELD
- PIN 2 — +28 VOLTS
- PIN 3 — AUDIO

CS-100/CS-100K MAIN STATION (FRONT PANEL)

FIGURE 3

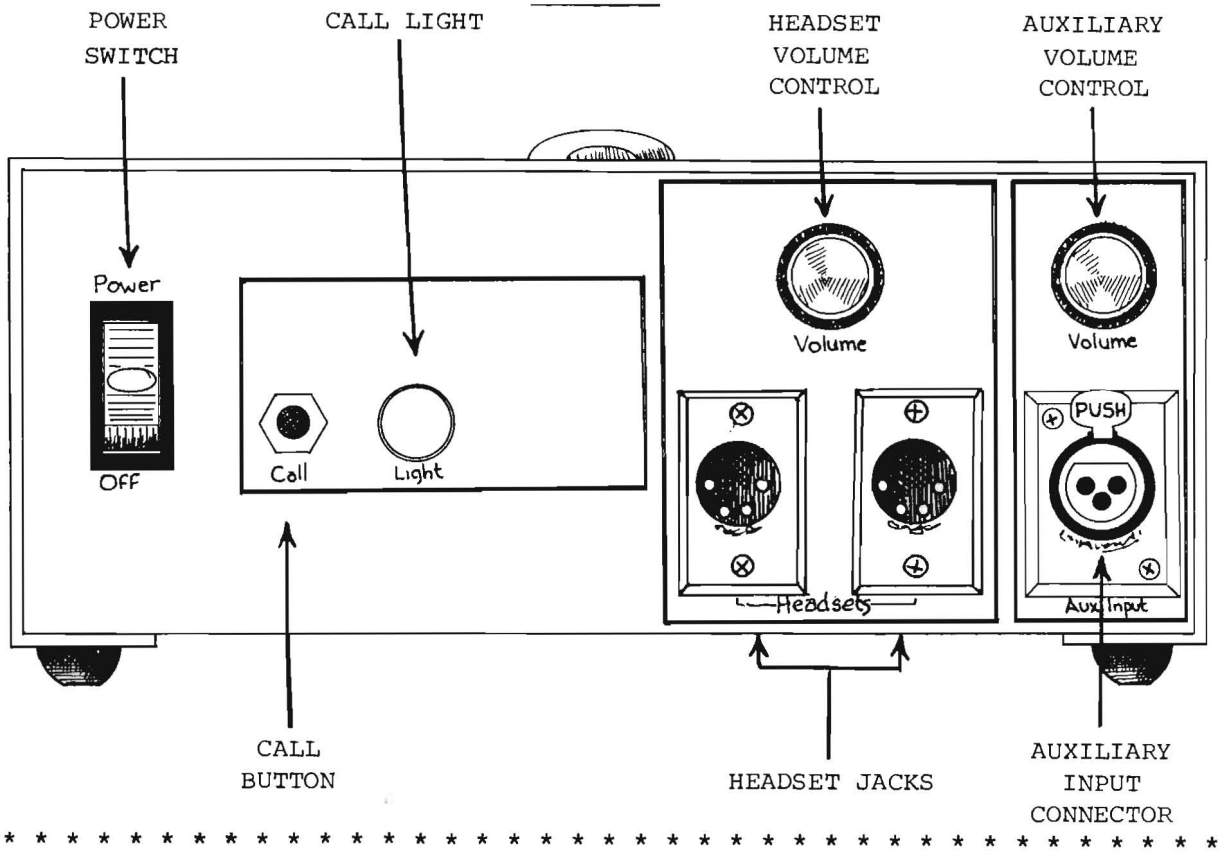

\*\*\*\*\*

CS-100/CS-100K MAIN STATION (BACK PANEL)

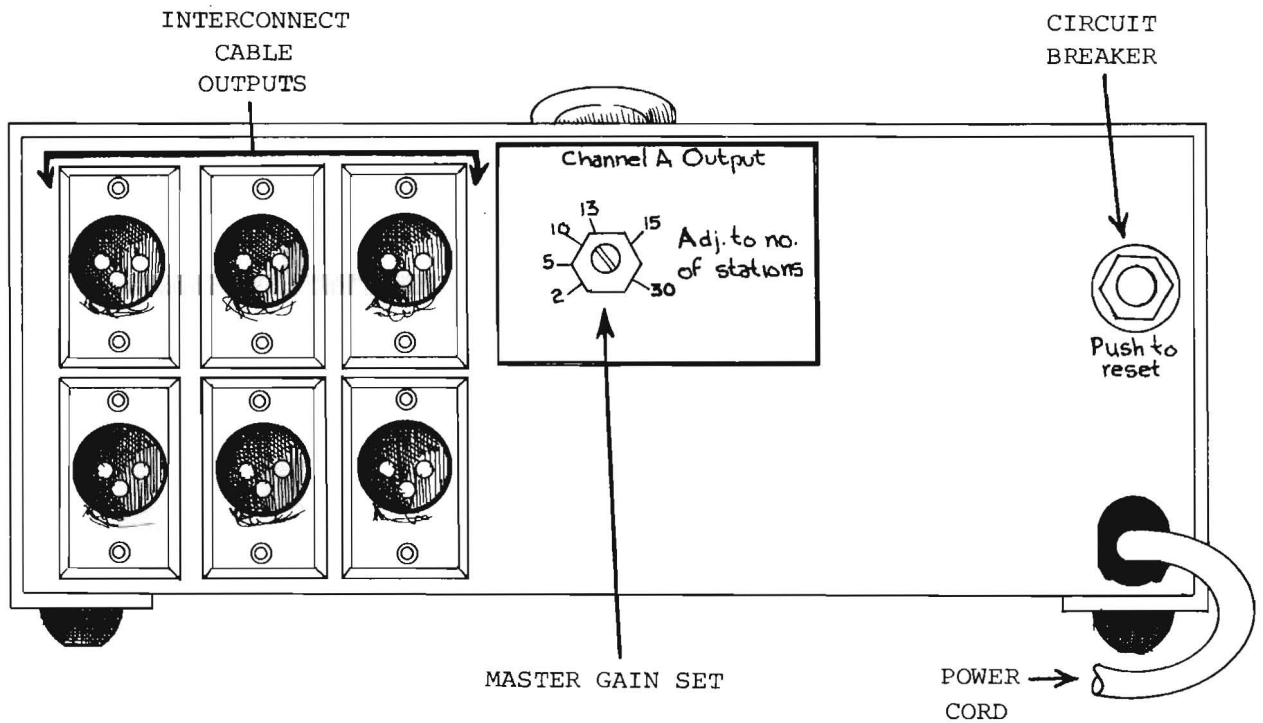
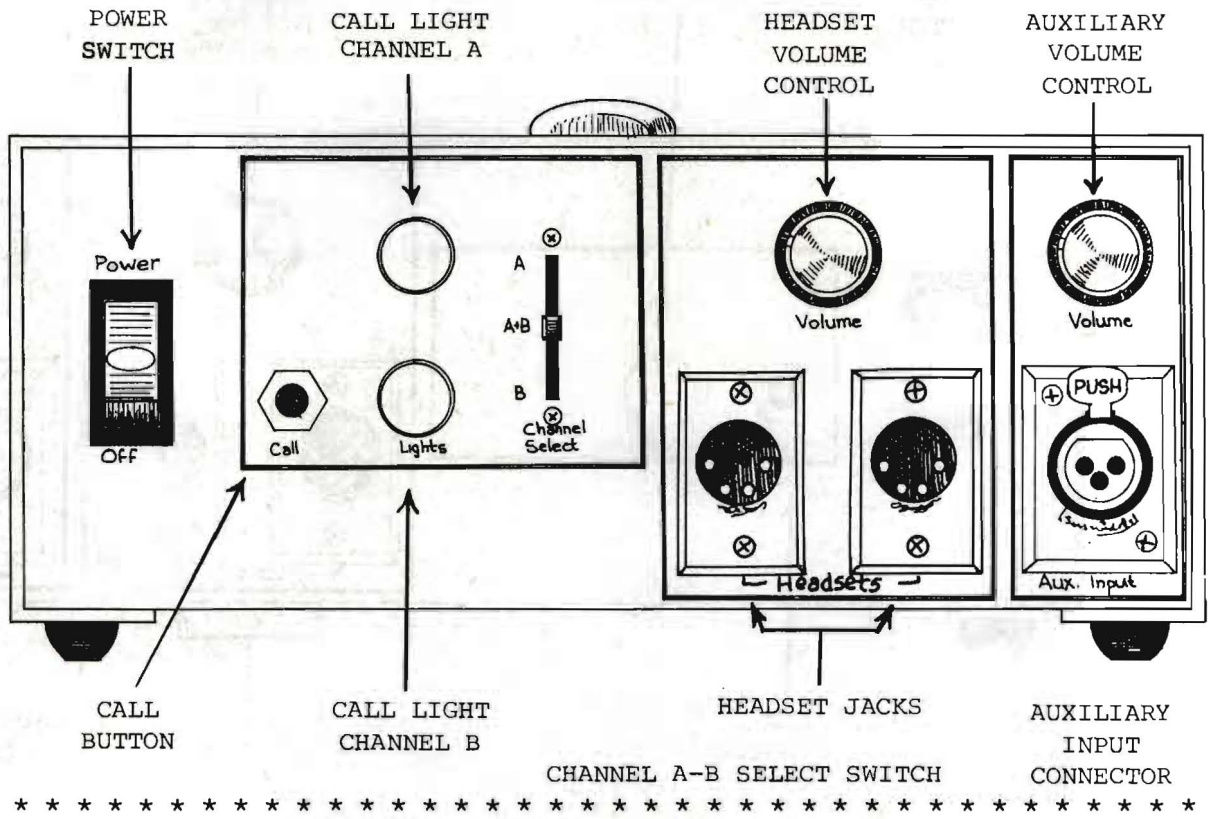

FIGURE 4

CS-200/CS-200K MAIN STATION (FRONT PANEL)

FIGURE 1



\*\*\*\*\*

CS-200/CS-200K MAIN STATION (BACK PANEL)

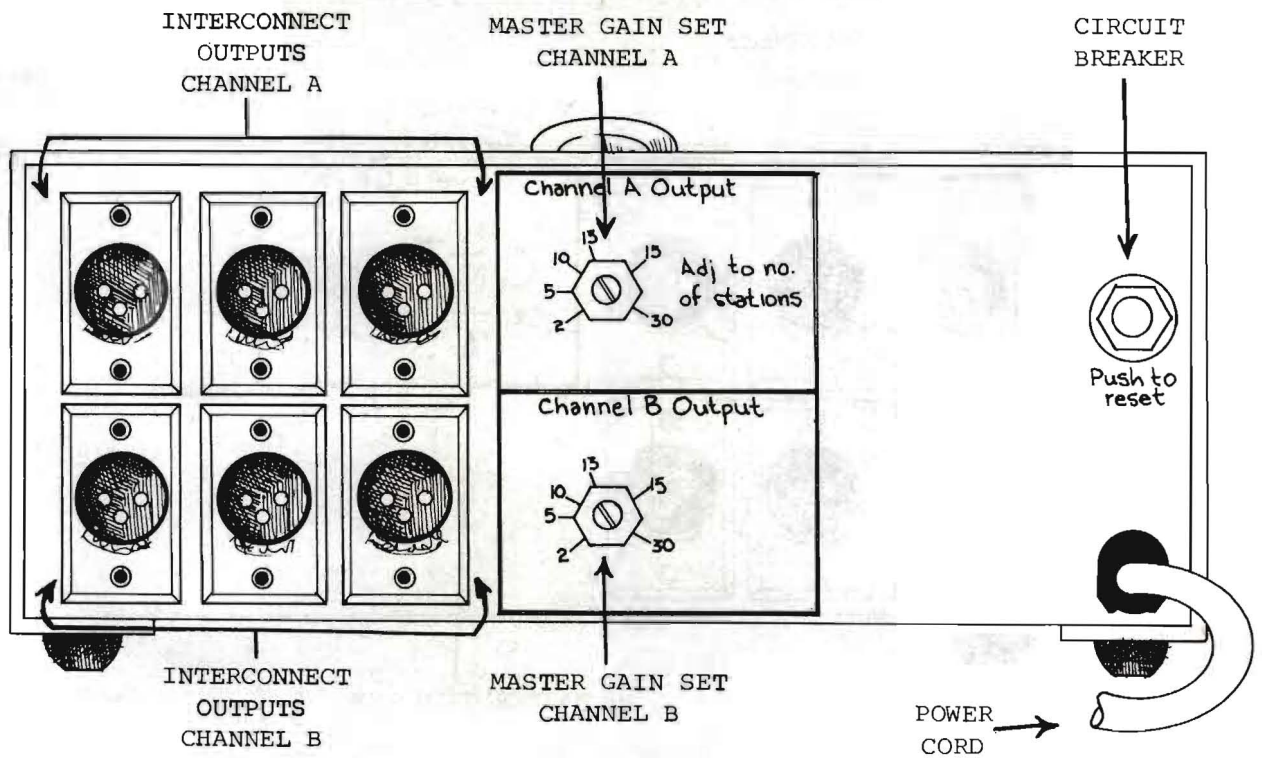
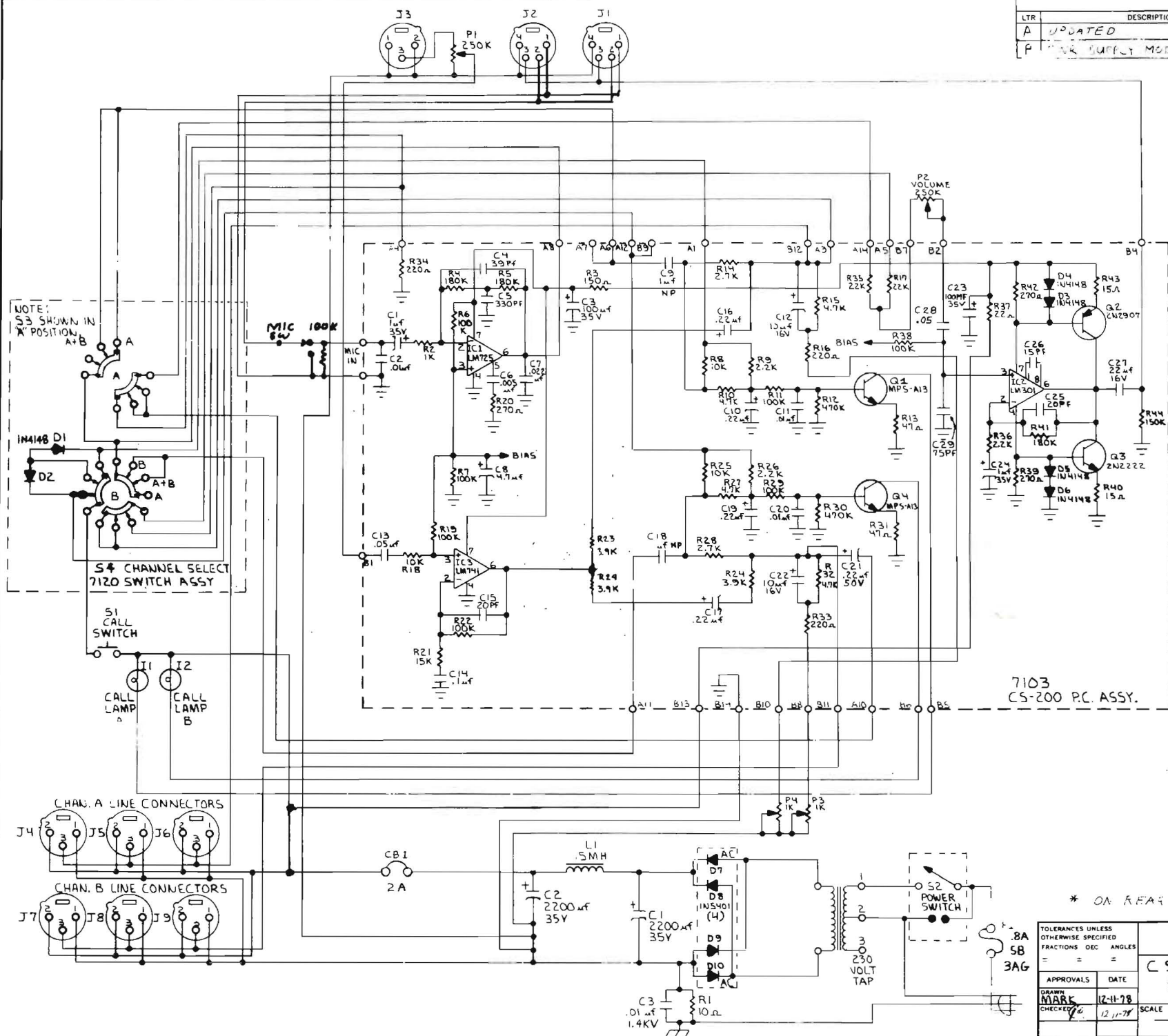

FIGURE 2

REVISIONS			
LTR	DESCRIPTION	DATE	APPROVED
A	UPDATED	5-17-78	
P	POWER SUPPLY MODS 2497	9-17-79	NIC



NOTE: S3 SHOWN IN 'X' POSITION A+B

7103 CS-200 PC. ASSY.

\* ON REAR PANEL

TOLERANCES UNLESS OTHERWISE SPECIFIED		FRACTIONS DEC ANGLES	
=		=	
APPROVALS	DATE	SCALE	SIZE
MARK	12-11-78		C
CHECKED	12-11-78		C-005
DRAWING NO.			DRAWING NO.
C-005			C-005
DO NOT SCALE DRAWING			SHEET 1 OF 1

REVISIONS			
LTR	DESCRIPTION	DATE	APPROVED
F	REVISED	6-7-79	
C	PWR. SUPPLY MODS	9-17-77	NIC

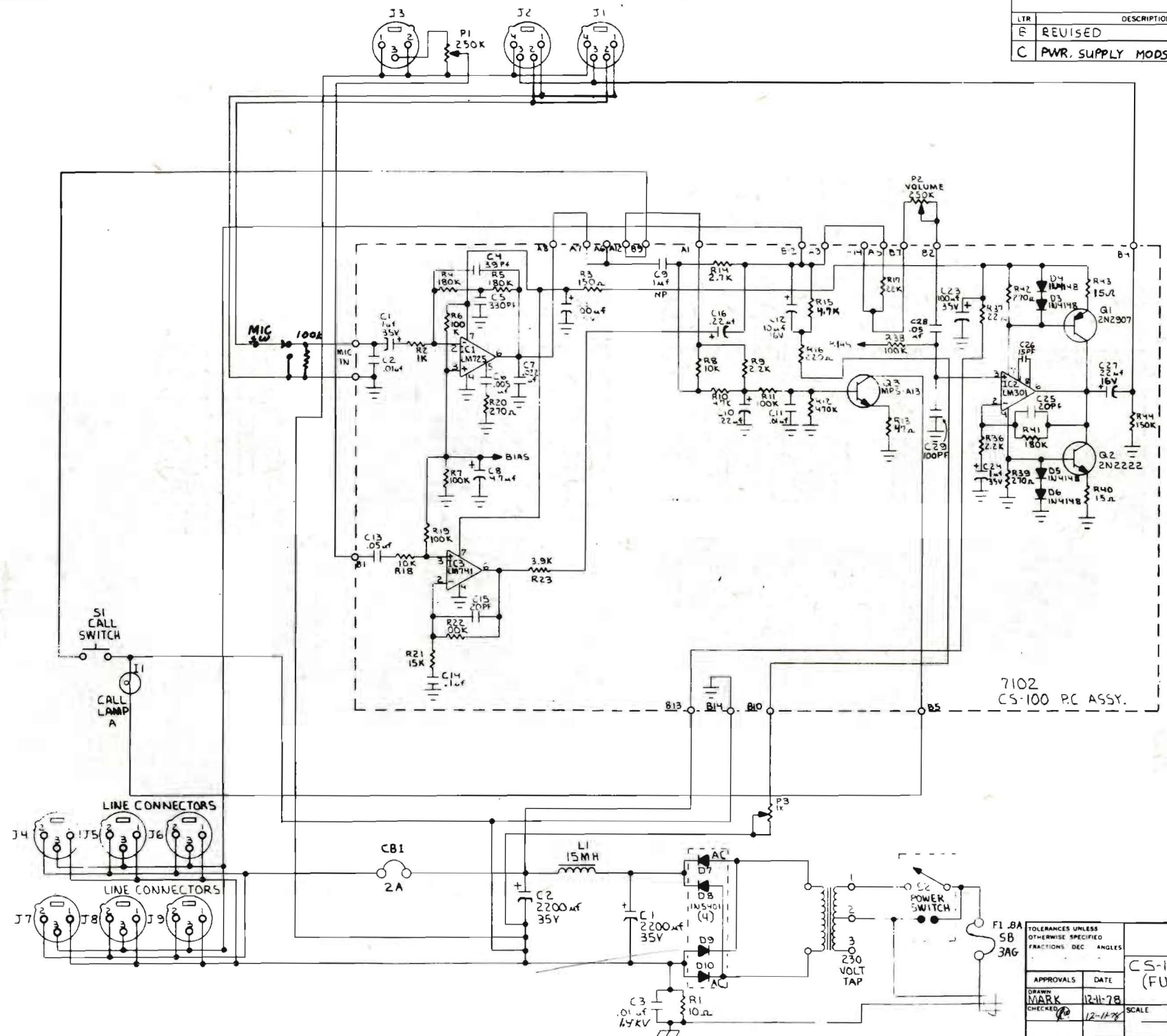

7102  
CS-100 PC ASSY.

APPROVALS		DATE	TOLERANCES UNLESS OTHERWISE SPECIFIED	
DRAWN MARK		12-11-78	FRACTIONS DEC ANGLES	
CHECKED [Signature]		12-11-78	SCALE	SIZE
			C	C-006
DO NOT SCALE DRAWING			SHEET 1 OF 1	

**Clear-Com.**  
intercom systems

CS-100 SCHEMATIC  
(FULL SYSTEM)

CS-100/CS-200 PARTS LIST

ITEM	PART #	DESCRIPTION	REF. DES.	CS-100 QTY.	CS-200 QTY.
1	1800	Choke, Filter	L1	1	1
2	4805	Diode, 3A 1N5401	D7, 8, 9, 10	4	4
3	1523	2000 mfd 35V	C1, C2	2	2
4	1529	.01 mf/1.4kV Capacitor	C3	3	3
5	5202	.5 Amp Circuit Breaker	CB1	1	1
6	3900	Call Light Assembly	I1, I2	1	2
7	3901	#327 Lamp, 28V.		1	2
8	2113	D4M Connectors	J1, J2	2	2
9	2102	D3F Connector	J3	1	1
10	2103	D3M Connectors	J4 - J9	6	6
11	4701	250K Pot 3/8" Bushing	P1, P2	2	2
12	4702	1K Pot 1/4" Bushing	P3, P4	1	2
13	7103	Amplifier Module	PC1	0	1
14	7102	Amplifier Module	PC1	1	0
15	4102	10 ohm 1/4w Resistor	R1	1	1
16	5100	Push Button	S1	1	1
17	5102	Power Switch	S2	1	1
18	5602	Power Transformer	T1	1	1
19	6000	Power Cord		1	1
20	7120	3 Position Lever Switch/ Plug Assembly	S3	0	1
21	2401	Knob		1	1
22	2402	Feet		4	4



## SPECIFICATIONS

### CS-100/CS-200 MAIN STATION

AMPLIFIER: Solid State IC plug in printed circuit amplifier module including signalling circuit. Current limited and short circuit protected.

FREQUENCY RESPONSE: 250 Hz - 10 KHz (-3 dB ref. to 1 KHz) with a rising response to enhance voice intelligibility.

HEADSET MICROPHONE INPUT LEVEL: -55 dBm.

HEADPHONE OUTPUT LEVEL: 9 volts rms into 600  $\Omega$  maximum. (-20dBm)

DISTORTION: Less than 0.5%.

SYSTEM IMPEDANCE AND LEVEL: Approximately -25 dBm into 200 (Level dependent on master gain control settings)

AUXILIARY INPUT AUDIO LEVEL: 100 mv into 600  $\Omega$  minimum.

CHANNEL SEPARATION (CS-200):  $\geq$  45 dB.

HEADSET INPUT CONNECTOR: 2 - 4 pin connectors (D4M)

INTERCONNECT OUTPUT CONNECTORS:

CS-100:	6 each in parallel, Switchcraft D3M.
CS-200: Channel A:	3 each in parallel, Switchcraft D3M.
Channel B:	3 each in parallel, Switchcraft D3M.

AUXILIARY INPUT CONNECTOR: Switchcraft D3M.

POWER SUPPLY: 28 volts circuit breaker protected.

CAPACITY: Will support up to 40 RS-100A or MR-102 remote stations or 15 KB-100 or KB-111 remote stations.

POWER REQUIREMENTS: 115/230 volts 50-60 Hz. 80 watts maximum.

DIMENSIONS:

CS-100/CS-200:	9.5"L X 4"H X 8.5"D.
CS-100K/CS-200K:	19"L X 3.5"H X 9.125"D.

WEIGHT:

CS-100/CS-200:	6 lbs. 14 oz.
CS-100K/CS-200K:	6 lbs. 15 oz.