



CLIMATE CONTROL SYSTEM OPERATION, DIAGNOSIS, AND REPAIR

Welcome to Climate Control System Operation, Diagnosis, and Repair, which is the final training course in the Electrical training sequence. When you have completed this course, you will know how to verify, diagnose, repair, and recheck problems related to the climate control systems (refrigerant loop, heater, controls, and automatic temperature control).

This course will teach you the diagnostic and repair skills you need to “fix it right the first time” so you have satisfied customers instead of unhappy ones. Just like any other automotive system, many Climate Control concerns are simple to solve, while others are tricky to diagnose or require repairs to multiple components when one component's failure damages others.

Completing this course helps prepare you for the ASE certification test for Air Conditioning. Because ASE exams use domestic car terminology, you may want to check out some ASE test preparation books from your local public library to finish studying for the exam. Besides the obvious benefit that ASE certification shows your expertise in auto repair, studying for the exams improves your skills.



WHAT IS CLIMATE CONTROL?

Climate Control refers to the systems in a vehicle that allow customers to adjust air temperature, humidity, and direction of discharged air. Although we usually think of climate control as just a comfort feature, the defroster is a safety feature. Air conditioning also improves the air quality, which may benefit people with certain health problems, by dehumidifying and cleaning the air as its cooled passing over the evaporator fins.

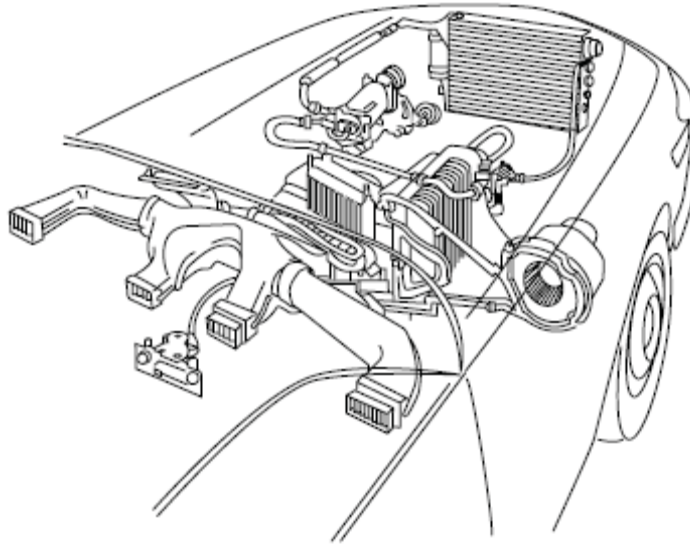

All the components of the Climate Control system work together as a complete system. Understanding the relationship between these components will help you accurately verify and diagnose complaints. For example, when a customer selects Defrost, the system opens the fresh air intake door, activates the heater core and refrigerant loop, directs air over the evaporator and the heater core, and blows this warm, dry air through the defroster ducts on the dashboard. If any one of these components isn't working properly, the customer will have concerns about poor defroster performance. Similarly, a customer may have concerns with poor air conditioner performance if the Sunload sensor has failed and the ATC is no longer accounting for the heating caused by sunlight on the vehicle.



SYSTEM OVERVIEW

All Nissan and Infiniti vehicles, except the first and second generation Nissan Quests, have the same basic refrigerant loop components, and all models except the Frontier, Xterra, Versa, Cube, and Sentra are available with ATC. Once you've learned how the basic systems work, you can apply this knowledge to any vehicle.

The five major components of the refrigerant loop are:

- Evaporator
- Compressor
- Condenser
- Liquid tank (receiver/drier)
- Expansion valve

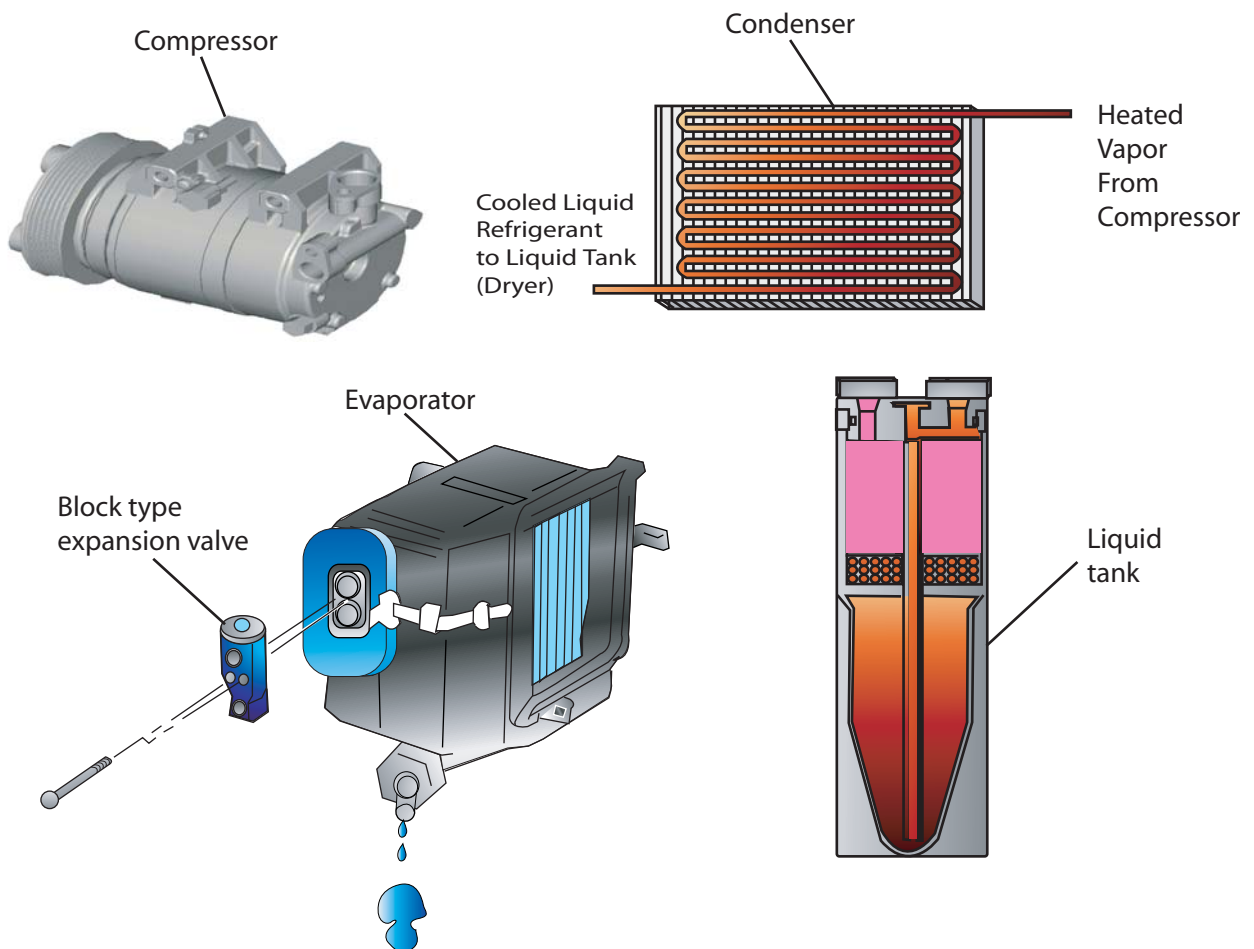

NOTE: The receiver/drier is referred to as the “liquid tank” in electronic service manuals.

The basic operation of the refrigerant loop is quite simple: it moves heat from the interior of the vehicle to the outside air.

- The compressor compresses the refrigerant and directs it through the system.
- The condenser transfers heat to the outside air and condenses the refrigerant to a liquid.
- The receiver drier (liquid tank) filters the refrigerant and stores any excess liquid.
- The thermal expansion valve (TXV) sprays a mist of refrigerant into the evaporator to start the loop again.
- The evaporator absorbs heat from inside the passenger compartment and incoming air when the intake is set to FRESH.

All these components are connected by rigid metal tubes and flexible hoses, and are sealed with various seals and O-rings.

A variation of this basic system layout is found in the first and second generation Nissan Quest, which has a fixed orifice tube (FOT) and an accumulator in the basic system and a thermal expansion valve (TXV) in the optional rear air conditioner.

The engine compartment is a harsh environment due to vibration and heat, so it's no surprise the most common A/C problem is low refrigerant charge due to gradual leakage.

System Diagram - Refrigerant Loop Components

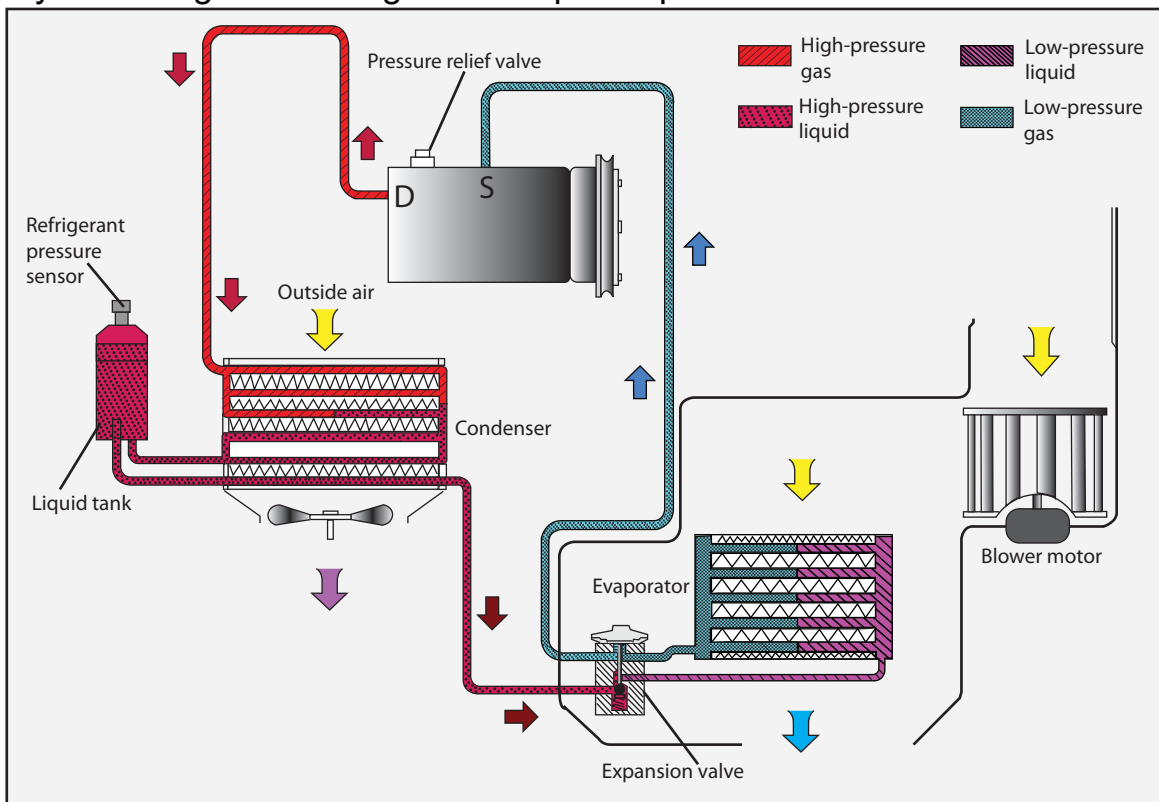



Review Questions

1. Climate Control allows customers to do which function: (Check all that apply)
 - Allow customers to adjust air temperature, control humidity, and the direction of discharged air
 - Allow customers to set the in-vehicle temperature to a comfortable setting
 - Create an environment warmer, colder, or more comfortable than the ambient (outside air)
 - All of the above
2. The compressor performs which of the following functions:
 - The compressor transfers heat to the outside air
 - The compressor filters and stores the refrigerant
 - The compressor compresses the refrigerant and directs it through the system
 - Absorbs heat from the passenger compartment

Safety

Automotive air conditioners operate under high pressures and use refrigerants that can be dangerous if improperly handled. Service and repairs should be performed only by properly trained persons who understand refrigeration systems and their operation. They must have access to specialized service tools and equipment while following approved safety precautions. Additionally, any HVAC system refrigerant recovery repairs require special licensing.

- Always wear eye protection when working on the refrigerant loop. If refrigerant contacts your eye it may freeze and cause permanent injury.



- Refrigerant can quickly cause frostbite. Avoid skin contact with refrigerant. Always wear gloves when working with refrigerant.
- Work in a well ventilated area. Since refrigerant evaporates quickly, breathing may become difficult due to lack of oxygen in poorly ventilated areas.
- Keep refrigerant away from open flame. Poisonous gas is produced when R-12 refrigerant burns.
- Never heat liquid refrigerant above 104° F. as this may cause the container to explode. Never apply direct flame to a refrigerant container.
- Keep refrigerant containers stored below 104° F.
- Never release refrigerant directly into the atmosphere. It's a federal law with fines and imprisonment for anyone releasing refrigerant into the atmosphere. Always use approved recovery, recycling, and charging equipment.



- Never mix R-134a and R-12 or their refrigerant oils. Results will range from poor A/C system performance to expensive component and equipment damage.
- There are many different Federal, state, and local ordinances controlling the use of refrigerants and their release into the atmosphere. Make sure you comply with these ordinances, including training and certification.

Refrigerant

Operation

The refrigerant in an air conditioning system absorbs, transports, and then releases heat via the condenser. A good refrigerant must have a number of specific characteristics. It must be:

- Compatible with a wide variety of materials such as brass, aluminum, copper, steel, rubber and neoprene.
- Oil soluble, which allows it to circulate through the system with the oil.
- Non-poisonous and non-flammable.

Unfortunately, no single substance found in nature has all these characteristics. Automotive refrigerants are man-made compounds developed especially for automotive air conditioning systems.

Automotive refrigerant has changed over the years from ammonia gas, to R12 (Freon), to R134a. The characteristics of each gas and the purpose in the refrigerant system have remained the same. The primary automotive refrigerant in general use today is R134a. Although the name "Freon" is sometimes used to refer to any automotive refrigerant, "Freon" is a registered trademark of DuPont.

R134a refrigerant is more environmentally friendly than R-12. Systems using R134a have slightly higher pressures than an R12 system. In addition, R134a systems use a different type of refrigerant oil which is specific to the type of compressor. R134a systems use a lower charge of refrigerant compared to R12 systems.

There is a distinct temperature-pressure relationship for R-134a refrigerant. As the pressure increases, the boiling point rises. Refer to the chart on the following page for these relationships.



R134a Temperature - Pressure Comparison

Temp °F	Pressure psig	Temp °F	Pressure psig
16	15.3	100	124
18	16.7	102	129
20	18.0	104	133
22	19.4	106	137
24	21.9	108	142
26	22.4	110	147
28	24.0	112	152
30	25.6	114	156
32	27.3	116	162
34	29.0	118	167
36	30.8	120	172
38	32.6	122	178
40	34.5	124	182
45	39.5	126	188
50	44.9	128	194
55	50.7	130	200
60	56.9	135	215
65	63.6	140	230
70	70.7	145	247
75	78.3	150	264
80	88.4	155	283
85	95.0	160	301
90	104	165	321
95	114	170	342

**E
V
A
P
O
R
A
T
O
R**

**R
A
N
G
E**

**C
O
N
D
E
N
S
E
R**

**R
A
N
G
E**

Review Question

1. Refrigerant should be compatible with which of the following materials: (Check all that apply)
 - Brass, aluminum, copper, steel, rubber, neoprene
 - Titanium, magnesium, copper, steel, rubber, neoprene
 - Steel, neoprene, synthetic oil, cosmoline
 - Brass, magnesium, copper, galvanized steel

Malfunctions

All automotive A/C systems eventually require service. A typical A/C system needs recharging every three or four years, and contamination in the system (water, incorrect oil, dirt, metal fragments, acids) can cause a wide variety of problems. Much contamination can be prevented by keeping things clean while working on the HVAC system. Make sure all valves and fittings are free of grease and dirt, and keep the protective caps on components, lines, and hoses until ready for installation. Always flush the system using equipment made for flushing AC systems after failure of the compressor, receiver/drier, or accumulator, as these components can introduce debris into the system when they fail. Always verify you are using the right type of oil for the compressor.

Diagnosis

Cooling performance will be inadequate if the refrigerant is undercharged. To rule out other causes of poor cooling performance, perform touch and feel diagnosis. If the refrigerant charge is low, the thermal expansion valve and receiver/drier (or the fixed orifice tube) will be warm or slightly cool to the touch. Both high-pressure and low-pressure readings are low if refrigerant undercharge is the cause. Always check for leaks and make any required repairs before recharging the AC system. As a rule of thumb, never increase the amount of R134a refrigerant charged into the AC system. R134a systems operate more efficiently than R12 systems and require less refrigerant.

The compressor may be noisy if the refrigerant is overcharged. If the A/C alternates between working well and not working, an excessive refrigerant charge may be causing icing. If both high-pressure and low-pressure readings are high, and particularly if splashing water on the condenser lowers the pressure, you will need to remove enough refrigerant to meet the specification in the service manual.

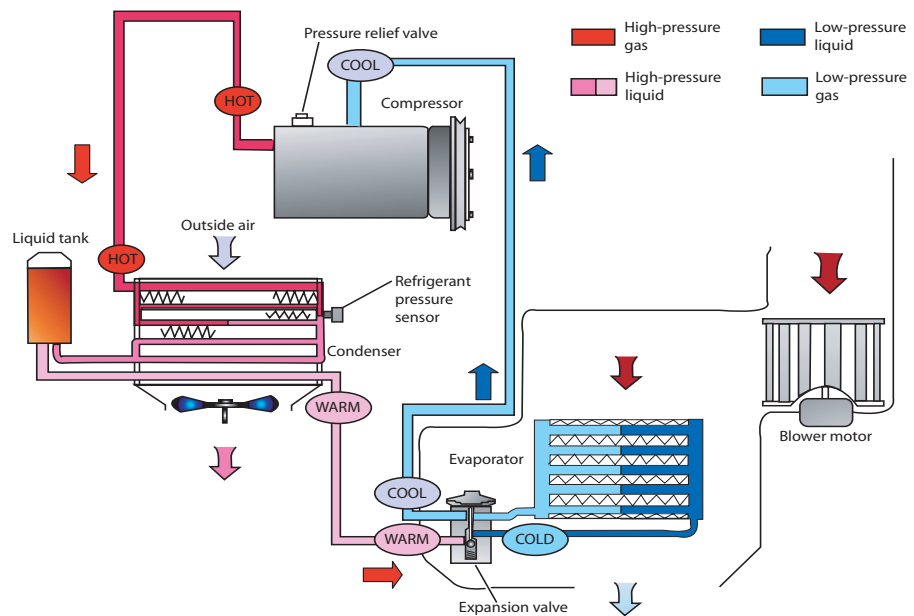



A better understanding of basic principles of refrigeration, makes diagnosing A/C problems easier. Refrigeration works by taking advantage of a few simple physical principles:

1. Heat travels from high temperature to low temperature areas.
2. Compressing a gas or vapor increases both its temperature and pressure.
3. Removing heat from a gas or vapor makes it condense into a liquid.
4. Raising the temperature of a liquid makes it evaporate into a gas or vapor.

When refrigerant enters the evaporator as a mist, it vaporizes and absorbs heat from the passenger compartment and fresh intake air until the refrigerant leaves the evaporator as a slightly superheated vapor.

The vaporized refrigerant travels through the low-pressure vapor lines to the compressor. The pistons in the compressor pressurize the refrigerant raising its temperature.

This hot, high-pressure refrigerant vapor goes through the high-pressure vapor lines to the condenser at the front of the car. Because the refrigerant is much hotter than the outside air, air passing through the condenser absorbs heat from the refrigerant. As the refrigerant loses heat, it condenses to a liquid.

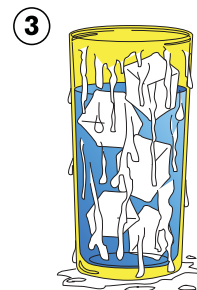
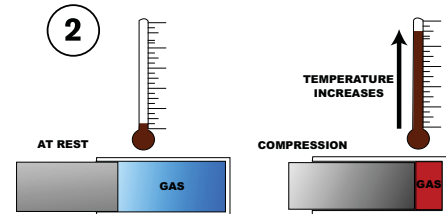

Next, the warm liquid refrigerant passes through the liquid line to the receiver/drier (liquid tank) to absorb any moisture or impurities which could damage the system.

System Diagram - Refrigerant Loop Components

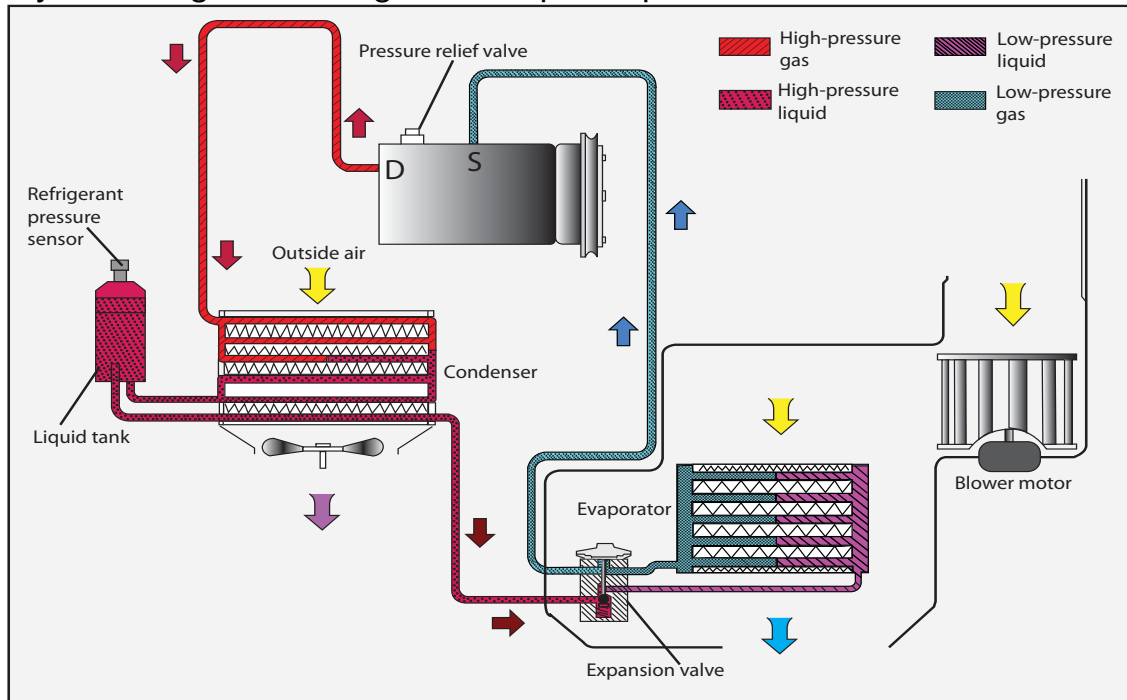

The refrigerant is still a warm liquid as it continues through the liquid line to the thermal expansion valve (TXV). When the refrigerant leaves the thermal expansion valve (TXV), the liquid refrigerant vaporizes. During normal system operation, the TXV allows enough liquid refrigerant into the evaporator to keep it partially filled with vaporizing liquid refrigerant while the system operates.

Review Questions

- R134a systems require charging a greater amount of refrigerant into the system compared to R12 systems: (Check one)
 - True
 - False
- Identify which of the following statements are correct: (Check all that apply)
 - Heat travels from high temperature to low temperature areas.
 - Compressing a gas or vapor increases both its temperature and pressure.
 - Removing heat from a gas or vapor makes it condense into a liquid.
 - Raising the temperature of a liquid makes it evaporate into a gas or vapor.
 - All of the above

Refrigerant Loop Components

The refrigerant loop consists of a group of components which are connected by rigid lines and flexible hoses which are sealed with O-rings and seals. There are also two service ports, one on the high pressure side and one on the low pressure side, to allow access to the refrigerant for diagnosis and repair.

System Diagram

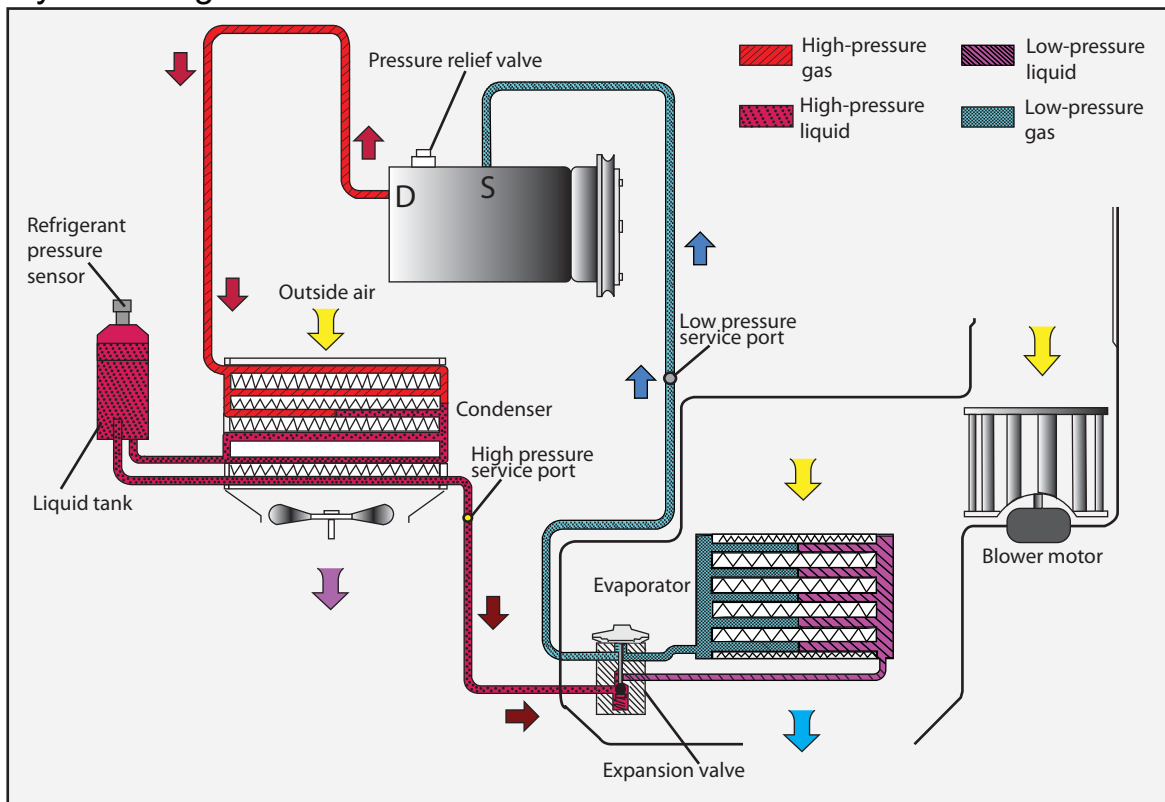

The major components in a standard thermal expansion valve (TXV) system are:

- Evaporator
- Compressor
- Compressor clutch
- Condenser
- Receiver/drier (liquid tank)
- Block type thermal expansion valve

Fixed Orifice Tube Systems (V40 and V41 Quest Only)

The front air conditioning system available on the first and second generation Quest is the only fixed orifice tube system used in a Nissan vehicle.

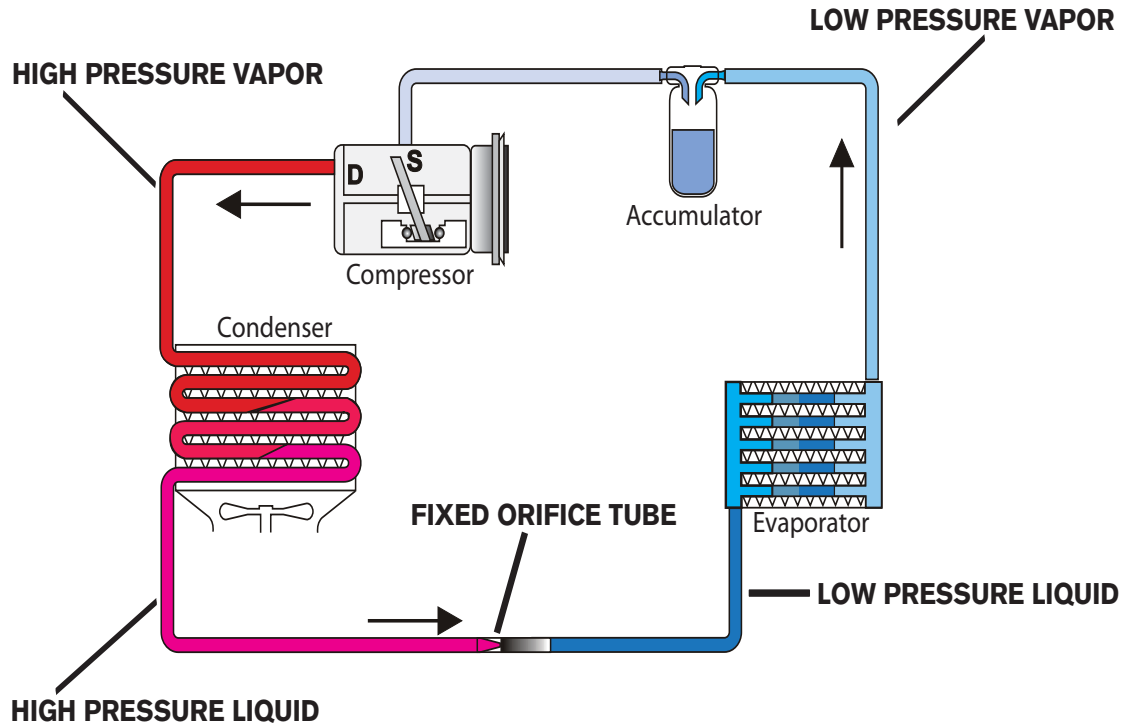

1. The compressor moves the refrigerant through the loop starting as a high pressure, high temperature vapor. Remember the temperature-pressure relationship.
2. Heat is released from the refrigerant to cooler air flowing over the condenser fins. This causes the refrigerant vapor to condense into a high pressure/high temperature liquid. The refrigerant leaves the condenser as a warm, high temperature, high pressure liquid.
3. The fixed orifice tube (FOT) uses a preset opening to reduce the pressure of the refrigerant and limit the amount of refrigerant entering the evaporator. Unlike the TXV, there is no feedback and no adjustment of refrigerant flow to increase efficiency. The refrigerant enters the fixed orifice tube as a warm, high pressure liquid and leaves as a low pressure, low temperature liquid before entering the evaporator.
4. In the evaporator, the refrigerant absorbs heat from the air circulating in the passenger compartment. This heat transfer causes the refrigerant to finish evaporating and cools the air in the passenger compartment. The refrigerant leaves the evaporator under low pressure as a low temperature vapor.



5. The refrigerant enters and leaves the accumulator as a low temperature, low pressure vapor. The accumulator stores, filters and removes moisture from the refrigerant. It also stores refrigerant oil and prevents liquid refrigerant from entering the compressor. Notice that the accumulator is located on the low pressure side of the refrigerant loop, while the receiver/drier (liquid tank) is located on the high pressure side.

NOTE: FOT systems use an accumulator to dry, filter, and store refrigerant. It is placed between the evaporator and the compressor to collect any liquid refrigerant in the low pressure lines before it reaches the compressor.

Compressor

Operation

The compressor moves the refrigerant through the refrigerant loop. It also pressurizes the refrigerant vapor until it becomes a high pressure, high temperature vapor, hot enough it can transfer heat to the outside air in the next component, the condenser.

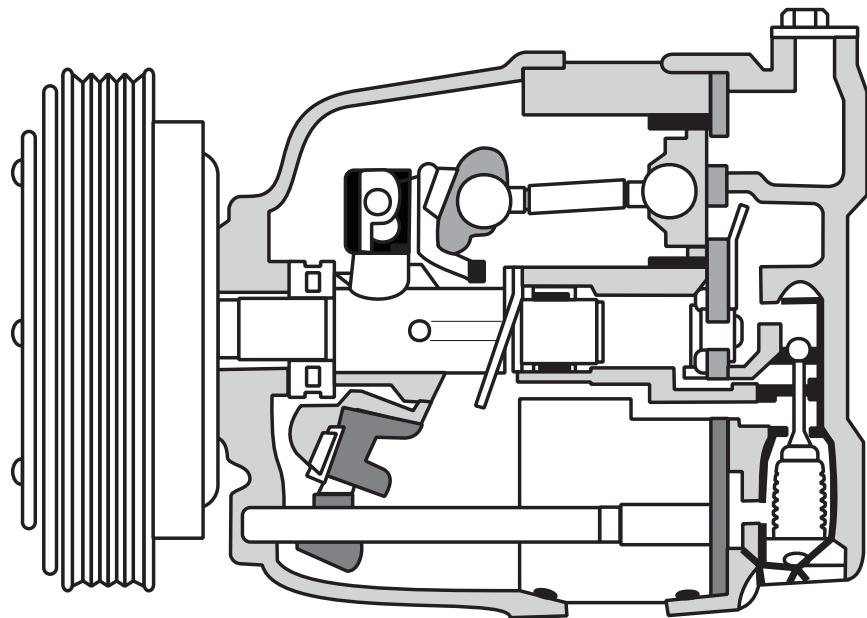

NOTE: The compressor circulates refrigerant oil throughout the system to lubricate other moving parts such as the expansion valve.

A system that uses a fixed displacement compressor, such as a fixed rotary vane type without a suction throttling valve or a swash plate type compressor will cycle the compressor ON and OFF to control evaporator (and interior) temperature.

Systems equipped with variable displacement compressors such as the V-5 and V-6 do not cycle ON and OFF. Instead of cycling during operation, the V-5 and V-6 compressors change displacement or refrigerant output to control evaporator temperature by using a pressure feedback system which controls piston stroke length.

Since the compressor circulates refrigerant oil along with the refrigerant, it is necessary to know what type of oil to use. There are different refrigerant oils based on the type of refrigerant. Poly-alkylene Glycol (PAG) oil is used for R-134a refrigerant.

V-6 Variable Displacement Compressor

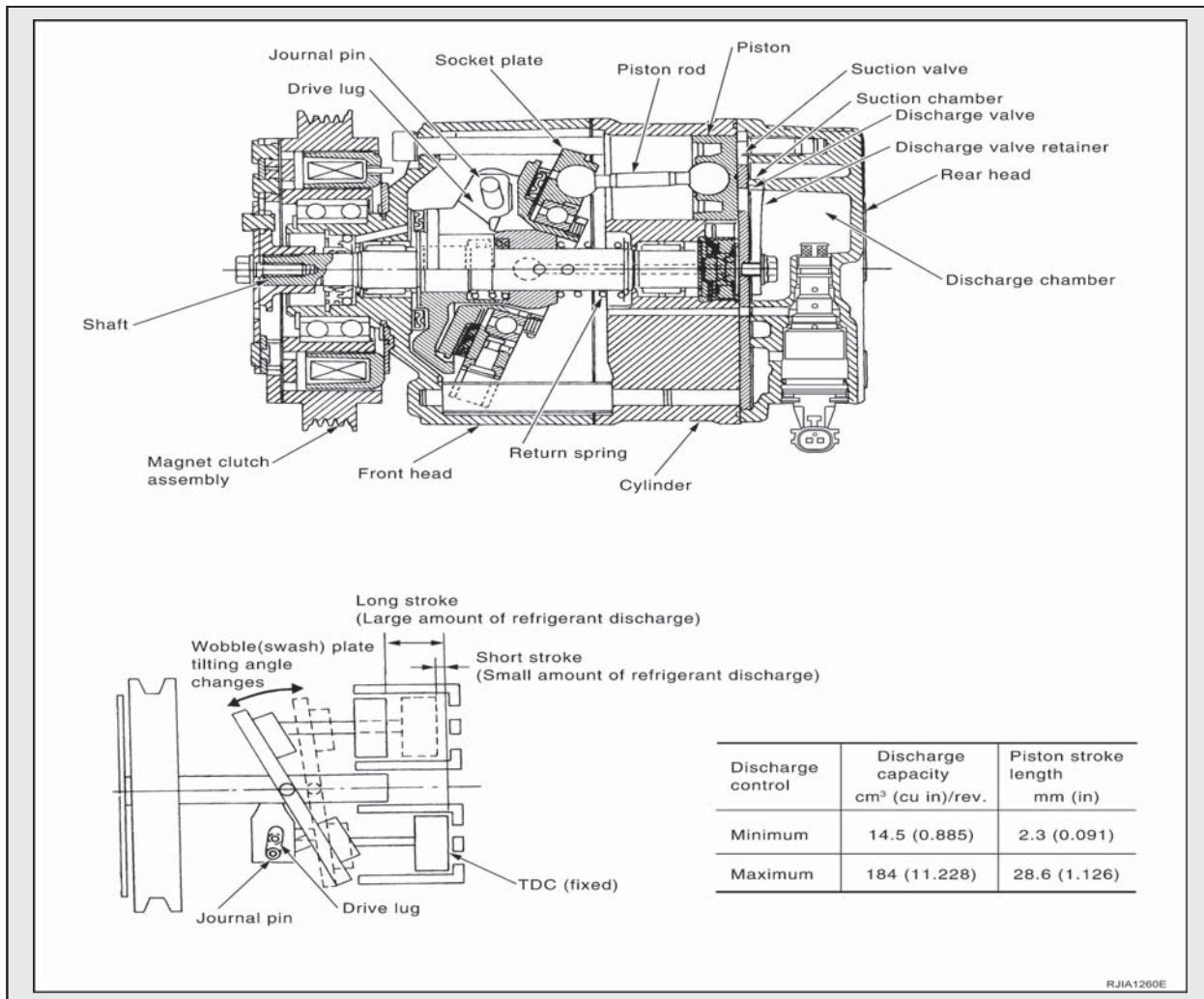

The V-6 variable displacement compressor magnet clutch remains engaged continuously rather than cycle ON and OFF as fixed displacement compressors do. The V-6 compressor provides a means of “refrigerant capacity control.” The variable displacement compressor is a swash type compressor that changes piston stroke in response to the required cooling capacity.

The tilt of the wobble (swash) plate allows the piston’s stroke to change so the refrigerant discharge can be continuously changed from 13.5 to 146 cm³ (0.824 to 8.91 cu. in.).

High interior heat load causes the compressor variable discharge to pump refrigerant at maximum capacity while low interior heat load causes the compressor variable discharge to pump refrigerant at minimum capacity. Once the interior reaches the desired temperature, the compressor minimizes the stroke which also minimizes the load on the engine.



Compressor Clutch

Operation

The compressor clutch is an electro-mechanical assembly that transfers mechanical power from the engine to the compressor via a belt. The clutch engages the compressor using an electromagnet in response to various sensor input signals. In older fixed-displacement compressors, the clutch would stop and start the compressor to control refrigerant flow. For swash-plate/variable-displacement compressors, the clutch operates continuously.

Malfunctions

Extreme operating conditions can cause the compressor clutch to fail. Compressor clutch problems are often mistaken for compressor failure, as mentioned in the discussion of the compressor.

Diagnosis

If the compressor is not operating, is operating poorly, or is operating noisily, check the compressor clutch and belt for slippage. Remove the belt and turn the compressor clutch by hand to check for noise and proper contact. (Caution: These parts may be hot.) Idler pulley bearings, when worn, also create a grinding noise that could be misdiagnosed as a compressor clutch or compressor.

The clutch should always remain engaged for variable-displacement compressors. Compressors that are fixed displacement should engage and disengage as the system cycles on and off. If the clutch does not engage, check the electrical circuit and also check the clutch to see if it engages when supplied with current.

On vehicles with an IPDM E/R, A quick test for compressor circuitry inspection is done using the AUTO ACTIVE TEST. See the appropriate ESM PG section for information on this test.

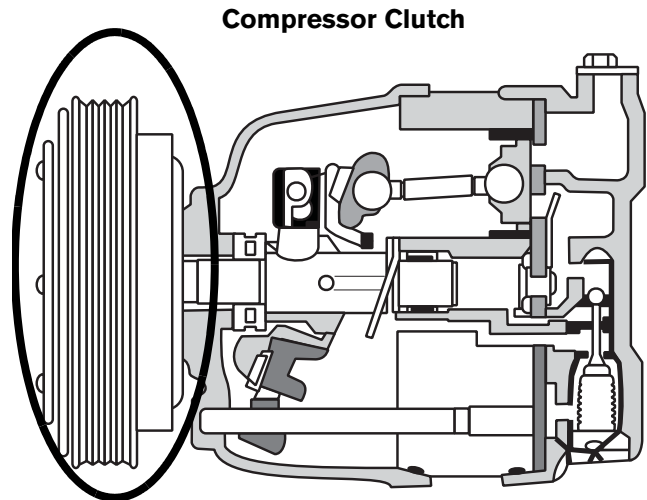

Refrigerant Lines and Hoses

Operation

Air conditioning system lines and hoses are an integral part of the system. They direct refrigerant and oil between system components and they prevent leaks under conditions ranging from low temperature and pressure to high temperature and pressure. Hose diameter and type is determined by the application: rigid tubing (lines) between the evaporator and liquid refrigerant lines (low temperature and pressure), and flexible tubing (hoses) between the condenser and the compressor (high pressure and temperature).

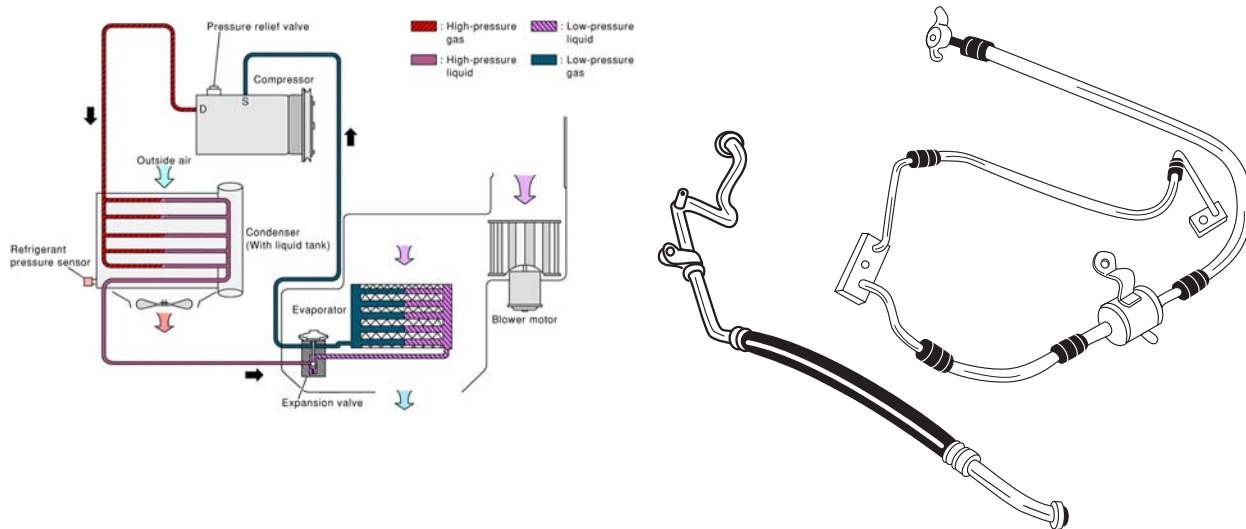

An easy way to tell which lines and hoses are high pressure and low pressure lines and hoses is the high pressure lines and hoses are smaller diameter than those for the low pressure side of the system.

In the past, lines and hoses relied on refrigerant oil to seal the hoses and prevent leakage at hose and line fittings. Newer air conditioning systems use barrier-type hoses that are self-sealing and prevent refrigerant leakage with or without refrigerant oil.



Condenser

Operation

The condenser operates very much like the radiator in a car, transferring heat to the outside air by passing hot coolant through a collection of tubes and fins. Both the condenser and the radiator are placed at the front of the vehicle and have fans to ensure air flow even when the vehicle is stopped in traffic.

After refrigerant leaves the compressor, it enters the condenser as a high temperature, high pressure vapor. As the refrigerant travels through the condenser it is cooled by outside air flowing over the condenser fins. The refrigerant in the condenser coils changes from a vapor to a liquid and leaves the condenser as a warm, high pressure liquid. Because the refrigerant temperature is so high when it enters the condenser, it is always hotter than the outside air, and can lose heat to the air even on a hot day. However, just like the radiator, the condenser transfers heat least effectively when you need it the most-when it's very hot outside.

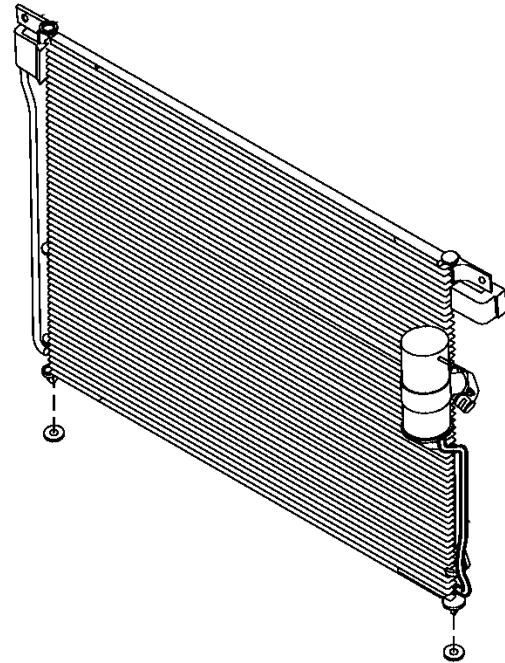

Three types of condenser are used in Nissan and Infiniti vehicles: serpentine flow, parallel flow, and sub-cooling. You can identify the parallel flow condenser by the refrigerant end tank and smaller, more closely spaced center section tubes, as illustrated above.

Sub-cooling Condenser

The sub-cooling condenser has an extra cooling pass inlet between the receiver/drier and the lower third of the condenser for extra cooling/condensing power.

Malfunctions

Condenser malfunctions are usually caused by internal collision damage, or obstructed air flow through the cooling fins. Noise or a vibration may result from the condenser fins or lines touching the body due to deteriorating rubber mounts.

Diagnosis

If the condenser has internal restrictions, the air conditioner will be less efficient. Touch and feel diagnosis will show the high side is hot and the low side is warm. High side pressures will be

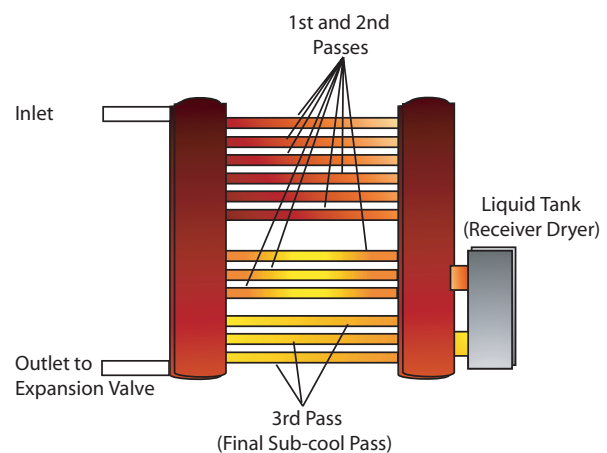

high and low side pressures will be low. Collision damage can crimp tubes without breaking them, causing a restriction rather than a leak.

Another cause of poor cooling performance is obstructed air flow, which can be diagnosed by inspection. Leaves, plastic bags, dirt, and other trash sticking to the front of the condenser block or limit air flow. Inspect for debris between the condenser and radiator while inspecting the climate control system. At low speeds an inoperative condenser fan can cause the same symptoms as obstructed air flow, so make sure the fan is operating. If an air flow problem exists, touch and feel diagnosis will show that both inlet and outlet are hot, as no heat is transferred out of the refrigerant. If you check with gauges, both high and low side pressures will be higher than normal.

The condenser tubes are often overlooked as a source of refrigerant leakage and should be checked thoroughly during a leak check procedure. Rocks or other debris on the highway may create a hole in the condenser tubes.

If the condenser seems to be making or transferring noise, check the rubber mounts for deterioration and replace if needed.

Liquid Tank (Receiver/Drier)

Operation

The receiver/drier, sometimes referred to as the liquid tank, is a container with an inlet and outlet at the top. The liquid tank contains filters and a layer of desiccant inside. Older models were cylindrical, but the new pointed base design makes it easier to recover small amounts of refrigerant at the bottom.

The receiver/drier has three functions in the refrigerant loop:

- Stores refrigerant
- Removes moisture from the refrigerant using a REFRIGERANT desiccant
- Filters contaminants and debris from the refrigerant

Malfunctions

Receiver/drier malfunctions are often caused by contaminants clogging the filter. The desiccant can only absorb a certain amount of water before it becomes saturated. In either case, the receiver/drier requires replacement.

Diagnosis

If the receiver/dryer is restricted, discharge air will be warm. Touch and feel diagnosis will show the inlet is warm and the outlet is cold. Frost may even appear on the bottom of the receiver/drier. When a restriction is present, manifold gauge readings will show the high side to be high and the low side to be low or at a vacuum depending on the degree of restriction. This occurs

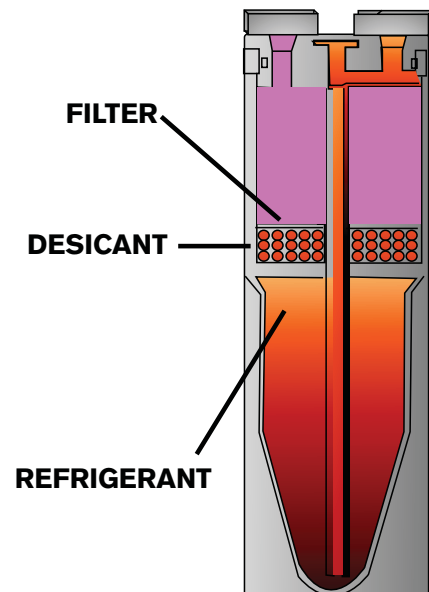



when refrigerant passes through the restriction. The refrigerant expands suddenly and loses heat, as if it were in a thermal expansion valve.

If the receiver/drier is saturated with moisture, the outlet air starts out cold but warms up in 5 to 10 minutes. Excessive moisture causes freezing in the thermal expansion valve when the refrigerant temperature drops. If this happens, touch and feel results show a warm inlet and a cold (even frosted) thermal expansion valve. Manifold gauge readings will be the same as those for a restricted receiver/drier.

NOTE: At one time, it was standard practice to replace the receiver/drier whenever the system was opened. In recent years, however, tests have shown this is no longer necessary due to improved desiccant materials. You may have already seen service bulletins directing technicians to reuse the receiver/drier in most circumstances. The receiver/drier should only be replaced if:

- The compressor is seized
- Refrigerant oil contains metallic flakes
- Diagnosis indicates a major blockage

If you can't document a specific reason to replace the receiver/drier, it will not be covered on warranty claims. If you encounter a car with a third-party extended warranty which requires receiver/drier replacement on all A/C work, discuss the situation with your Service Manager.

NOTE: This is sometimes a difficult problem to understand, when there is a restriction in the system like at the receiver/drier or at the expansion valve, the high side pressure is lower than normal. If there is less refrigerant going to the compressor from the restriction, the compressor has less to pump so the pressure is lower. If the restriction were close to the compressor then the refrigerant would hydro-lock and the pressure would be high. As long as there is room in the system to store the refrigerant between the compressor and the restriction, then the high side pressure is low.

Review Questions

1. The compressor performs which of the following operations: (Check all that apply)
 - Condenses refrigerant to a liquid
 - Moves refrigerant through the refrigerant loop
 - Reduces the pressure on the system so the refrigerant is able to vaporize in the evaporator
 - Pressurizes the refrigerant until it becomes a high pressure, high temperature vapor

2. Refrigerant enters the condenser in which of the following properties: (Check one)
 - Low pressure liquid
 - Low pressure gas
 - High pressure liquid
 - High pressure gas
3. The Liquid Tank performs which of the following tasks: (Check all that apply)
 - Stores refrigerant
 - Removes moisture from the refrigerant
 - Filters contaminants and debris from the refrigerant
 - Filters and stores excess refrigerant oil

HVAC Module and Intake Assembly

Operation

Most current HVAC systems consist of an HVAC module/unit assembly. The HVAC module assembly contains the heater core, the door system, and evaporator core. The blower housing is a separate unit. The cooling unit in the HVAC assembly contains the evaporator core, the block type thermal expansion valve, and the door system. The intake unit contains the intake door, thermo resistor or fan control amplifier, and a blower.

A control system (controlled manually or electronically) directs air over the heater core to raise the temperature, over the evaporator to lower the temperature and humidity, and through the desired vents. In vehicles with manual controls, the customer determines the airflow with a combination of settings, which directly control heating, air conditioning, vent position, and fresh air intake. With automatic temperature control (ATC), a central controller uses sensor input to control these components and determine which route air takes through the HVAC module. It also determines the most efficient fan speed.

HVAC UNIT

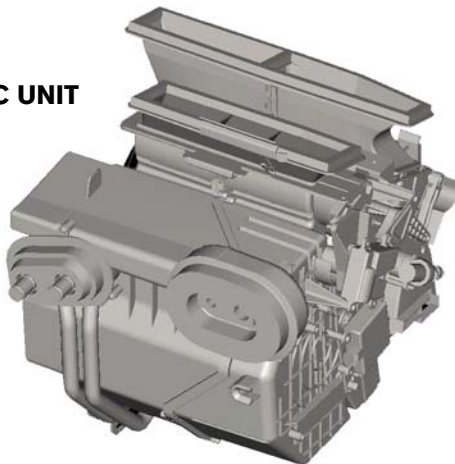

BLOWER UNIT

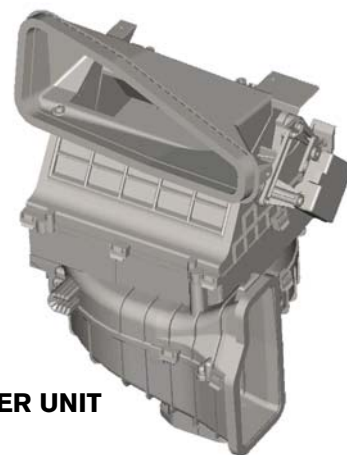

Malfunctions

Each of the A/C components is discussed separately, and the door system is discussed under ATC.



Intake Door

Operation

The intake door is automatically controlled by the unified meter and auto amplifier or the driver to help obtain the set temperature. The intake door motor positions the intake door to control either fresh outside air, recirculated air (air recirculated through the passenger compartment) or a mix of both fresh air and recirculated air into the passenger compartment. Refer to the service manual for each vehicle for the wiring diagram and physical location of the intake door motor.

Exceptions to automatic control occur in defrost mode. In defrost mode, the intake door is set in the fresh air position. In manual recirculate mode, the intake door is set in the recirculate position.

Malfunctions

The control rod to the intake door may be dislodged or mis-adjusted, or the intake door motor can fail. Also, the switch on the control panel or the connection to the auto amplifier can be damaged.

Diagnosis

If the intake door is stuck in the recirculate position, the defroster will be less effective and the air in the car may seem stuffy or musty. If the intake door is stuck in the fresh air position, this would be less noticeable except when trying to use the recirculate setting to avoid outside odors.

If the door is stuck midway, the defroster may be somewhat less effective, but otherwise this fault would not be very noticeable.

If the intake is stuck on fresh air, the air mix is stuck on hot, and the mode is stuck on defrost, check the unified meter and auto amplifier.

Using self-diagnosis, follow the directions in the service manual to find malfunctioning components and rule out other control problems.

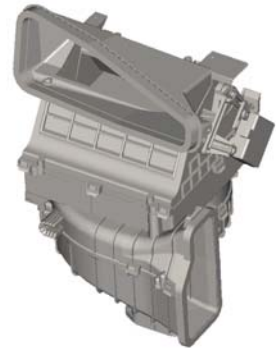

Thermal Expansion Valve

Operation

All Nissan and Infiniti vehicles (except the Quest's front air conditioner) use a thermal expansion valve (TXV) to control refrigerant flow into the evaporator. The TXV uses a controlled restriction for reducing refrigerant pressure and controlling the amount of refrigerant flow into the evaporator. Refrigerant enters the TXV as a warm, high pressure liquid. When refrigerant leaves the TXV, it is a cold, low pressure liquid just beginning to vaporize.

Refrigerant flow through the evaporator is moderated by feedback from a sensing bulb at the evaporator outlet tube. This sealed sensing bulb contains a gas that responds to the temperature of the refrigerant at the outlet of the evaporator and changes the pressure on the diaphragm in the TXV.

As the temperature of the evaporator rises, the valve opens to release more refrigerant. As the temperature falls, the valve closes to stop refrigerant flow and prevent evaporator icing.

On earlier expansion valves the sensing bulb must have good thermal contact with the evaporator's outlet tube, so it is usually wrapped with insulating foam tape.

All current Nissan and Infiniti vehicles use a Block Type Expansion Valve. This valve functions exactly the same as the standard expansion valve with one exception, the sensing bulb is contained in the valve housing.

It could be said that TX Vs use a variable valve controlled by a feedback mechanism, which allows changing the refrigerant flow volume in response to varying temperature conditions increasing efficiency.

Malfunctions

The TXV can stick open, stick closed or become restricted. The sensing bulb can also malfunction, causing the TXV to stay closed. The opening of the valve is very small. If the valve opening becomes restricted with contaminants, the TXV should be replaced along with the receiver/drier.

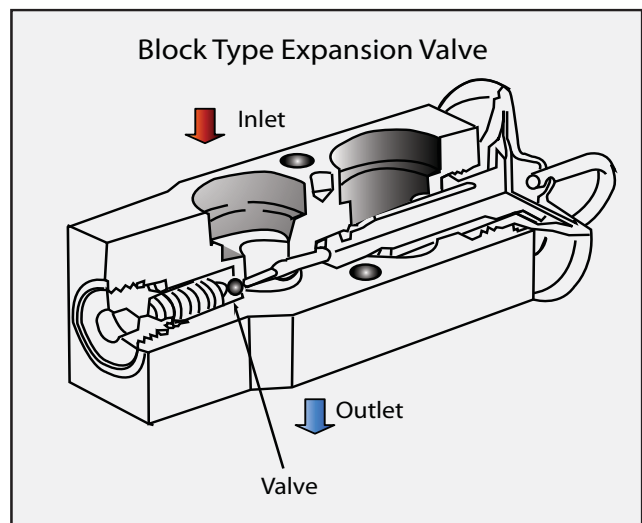
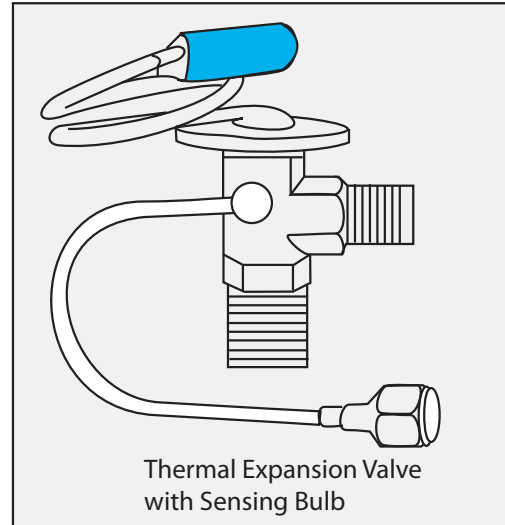



Diagnosis

A TXV that is stuck closed or partially restricted will cause the discharge air to be cool to warm. Not enough refrigerant enters the evaporator preventing efficient cooling. The high side of the system reads high and the low side of the system reads very low.

NOTE: When the TXV is closed all the way, refrigerant continues flowing through the valve. If there is debris in the valve then it could prevent the flow of refrigerant completely.

If the TXV is closed or completely restricted, you will not be able to hear the normal hissing or spraying sound. The discharge air will be warmer, the high side pressure will be higher than normal, and the low side may range from very low to a vacuum. Because no refrigerant is flowing into the evaporator, evaporator temperature remains high. A closed TXV may cause the compressor to run continually as it tries to cool the passenger compartment. Variable-displacement compressors will remain at maximum capacity. Fixed-displacement compressor systems will never cycle off. Contamination by particles typically restricts or closes the valve. Also, if the sensing bulb, its capillary tube, or the diaphragm has failed, the TXV will close. If examination of the failed TXV shows contamination, flush the system and replace the receiver/ drier.

If the TXV is stuck open and flooding the evaporator with refrigerant, outlet air will be slightly cool to warm. Touch and feel diagnosis will find the tubes leading from the TXV are quite cold, and frost or ice may be present. High side pressure will be slightly high and the low side will read high. A stuck open TXV may also cause the evaporator to freeze up. If the evaporator freezes, air flow from the outlet vents will be reduced. Ice formation can damage the evaporator, so this is a serious condition. Typically, water or wax contamination or mechanical failure will lock a TXV in the open position. If examination of the failed TXV shows contamination, flush the system and replace the TXV, tube, and receiver/ drier (Liquid Tank).

NOTE: The ACR5 AC Service Center has the capabilities of flushing an AC system. Refer to the owner's manual for the proper procedure and adapters.

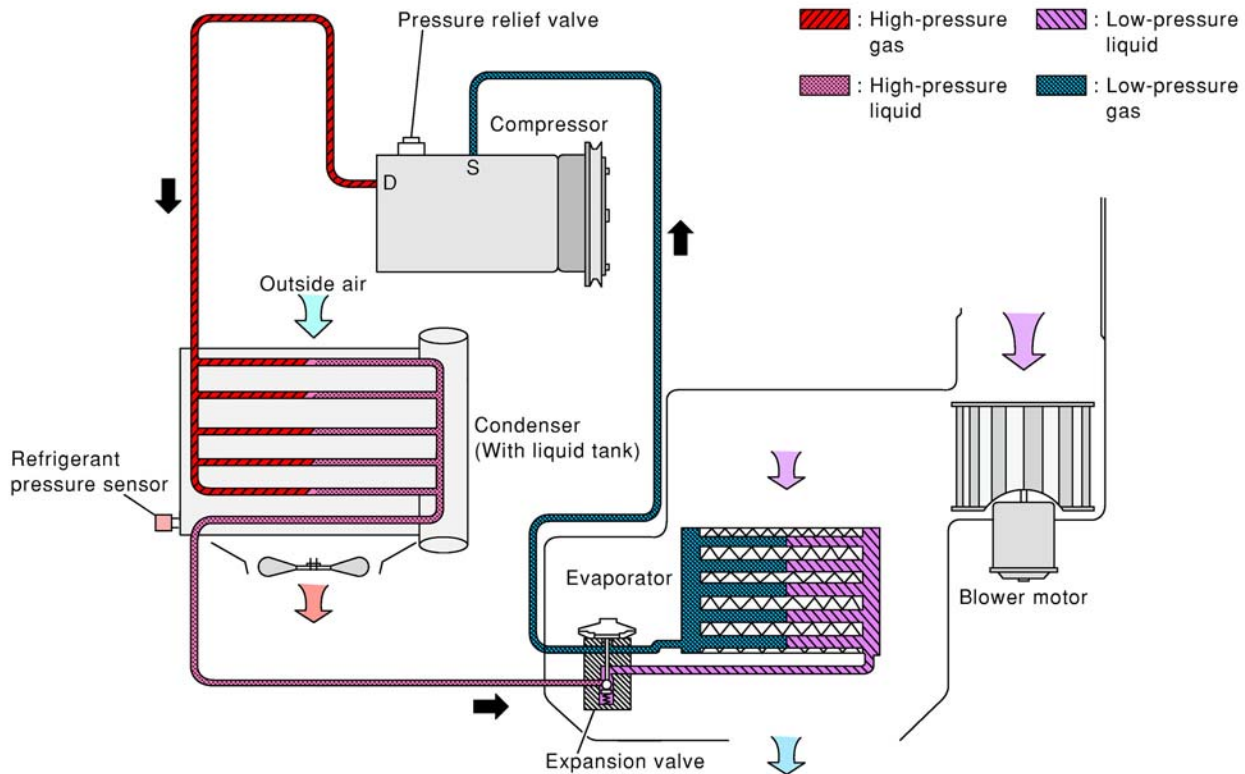

Block Type Thermal Expansion Valve (TXV) System

1. The compressor moves the refrigerant through the loop starting as a high pressure, high temperature vapor. Remember the temperature-pressure relationship.
2. Heat is released from the refrigerant to cooler air flowing over the condenser fins. This causes the refrigerant vapor to condense. The refrigerant leaves the condenser as a warm, high temperature, high pressure liquid.
3. The refrigerant enters and leaves the receiver/drier as a warm, high pressure liquid. The receiver/drier stores, filters and removes moisture from the refrigerant. Its equivalent in the fixed orifice system is the accumulator.
4. The thermal expansion valve (TXV) uses a variable restriction to reduce the pressure of the refrigerant and control the volume of refrigerant entering the evaporator. If too much refrigerant enters the evaporator, it will not completely evaporate. If too little refrigerant enters the evaporator, it will evaporate too quickly. In either case, the system will not cool efficiently.

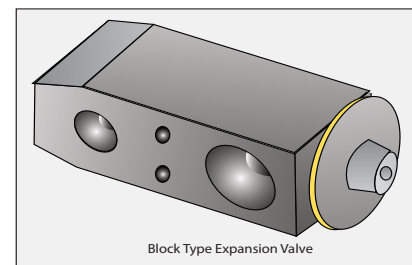

- In the evaporator, the refrigerant absorbs heat from the air circulating in the passenger compartment. This heat transfer causes the refrigerant to finish evaporating and cools the air in the passenger compartment. The refrigerant leaves the evaporator under low pressure as a low temperature vapor.

The sealed, gas-filled sensing bulb on the TXV senses the temperature of the evaporator and adjusts the TXV accordingly. Refrigerant enters the TXV as a warm, high pressure liquid and leaves as a low pressure, low temperature liquid as it enters the evaporator.

This feedback allows the thermal expansion valve system to operate more efficiently than a fixed orifice tube (FOT) system, which uses a preset opening to meter refrigerant.

Evaporator

Operation

The refrigerant entering the evaporator from the thermal expansion valve is a cold, low pressure liquid just starting to vaporize. As air flows across the evaporator fins the refrigerant continues to vaporize as it absorbs the heat transferred from the air to the evaporator.

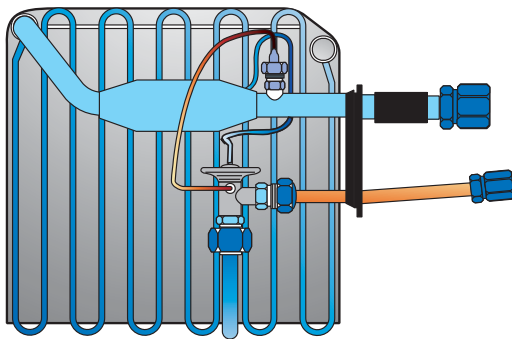

Previous Style Evaporator

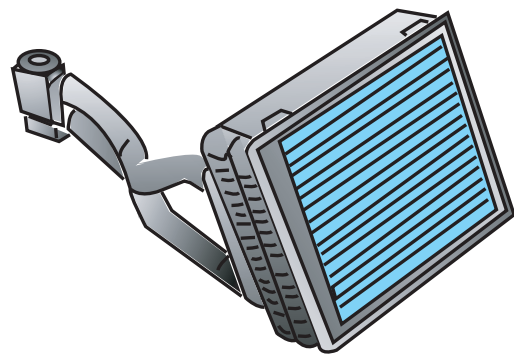

Newer Model Evaporator

The evaporator has a tube-and-vane construction similar to a radiator, and performs the same basic task: heat transfer. It is located in the HVAC module, along with a blower motor to circulate warm air past it to absorb the heat and send cooler air into the passenger compartment.

The evaporator also dehumidifies the air. As warm, humid air passes over the evaporator core, water in the air condenses on the cold evaporator, just like it does on a cold glass of your favorite beverage. Dry air feels cooler than its actual temperature and allows the body to cool itself more efficiently. Drying the air also relieves the sticky, clammy feeling of extremely humid air, and prevents humidity from building up on the

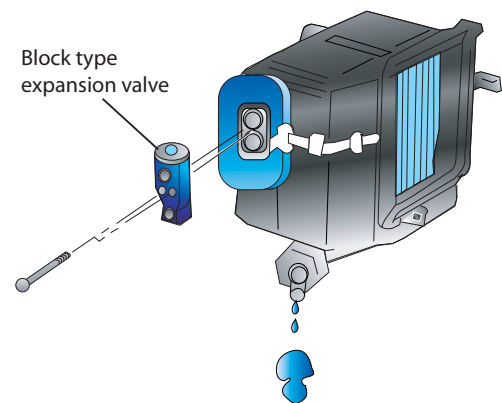

inside of the vehicle. Air being sent to the defroster vents also passes over the evaporator to remove excess moisture, which helps it clear fog from the windshield more effectively.

Malfunctions

The evaporator is a very reliable component. Evaporator malfunctions are limited to obstructed air flow or internal restrictions.

Air flow can be blocked by air flow through the In-Cabin Micro filter (if equipped) leaves, paper, or other debris falling into the HVAC module through the air intake or interior vents and being held against the evaporator by the air from the blower. Ice forming on the outside of the evaporator fins (see “Diagnosis” below), may also block air flow and reduce air conditioning performance.

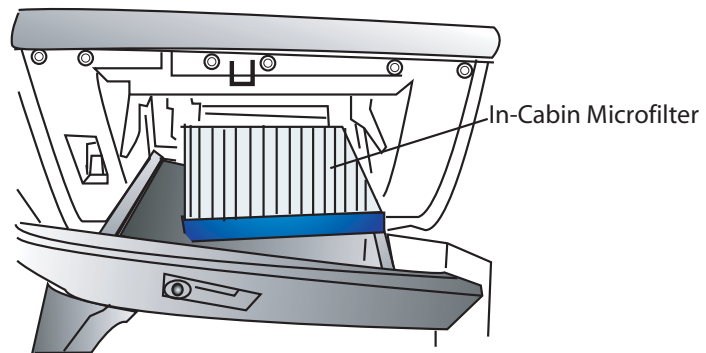

On vehicles with the In-Cabin Micro filter, the entry of airborne dust and pollen particles are filtered and restricted before they reach the evaporator coils.

If the Receiver/Drier fails, desiccant particles from the receiver/drier may lodge in the evaporator core, although they are more likely to clog the TXV. Replacing a damaged or failed receiver/drier or compressor without flushing the system may allow debris to reach the evaporator. This is why it's important to fix everything right the first time, and think ahead to the consequences of a component failure.

Moisture removed from the air collects in the evaporator housing and flows out a drain tube. Occasionally, debris will clog the drain and water will accumulate in the HVAC module. Customers typically are concerned about a stagnant odor or even water dripping on their feet when it sloshes out of the evaporator case on sharp turns. Except for this situation, musty odors from the evaporator are much less common now due to water-repelling and mildew-resistant coatings on the evaporator core and case.

To protect the mildew-resistant coating, never clean an evaporator with anything stronger than dish washing detergent or other mild soap.

Diagnosis

During touch and feel diagnosis (discussed later), the incoming line of a properly operating evaporator is cool, the evaporator is just above freezing, and the outgoing line is warm.

- Air flow through the discharge vents will decrease if air flow through the evaporator is obstructed. Check for leaves or other foreign objects inside the cooling unit.
- Evaporator icing can be a serious problem because the expansion of water as it freezes can crack the evaporator. When the humidity inside the vehicle is extremely high, water may condense on the evaporator and freeze if the surface temperature is cold enough.



- Ice buildup on the evaporator fins blocks air flow and causes symptoms noticed by the customer, such as poor or intermittent cooling. Except in conditions of excessive humidity, this is typically caused by a defective thermal expansion valve (TXV). Since it takes a while for ice to form, and it will often melt after the evaporator is blocked long enough for the temperature to rise above freezing, the customer may report that the air conditioner seems to work intermittently. However, if a variable discharge compressor fails so it is always in its maximum stroke position, this will also cause the same symptoms.
- Any water in the refrigerant may freeze inside the evaporator. The symptoms would be similar to the above, and would be cured by recycling the refrigerant to remove the water and replacing the receiver/drier or accumulator (liquid tank), as applicable.
- A restriction in the evaporator causes slightly cool air at the discharge vents. Touch and feel diagnosis shows the incoming line is cool, the evaporator is not as cold as it should be, and the outgoing line is also cool, due to poor heat transfer. High side pressures may be close to normal and low side pressures will be lower than normal. If the evaporator is completely restricted, you may get a vacuum reading on the low side manifold pressure gauge.

Lubricants

Operation

Automotive air conditioning lubricants are specially formulated because of how and where they operate. Air conditioning oils must be “dry” (having little or no water content) and mix with the system's refrigerant so they can circulate. They must lubricate system components under temperatures ranging from -30° F to 200° F. Refrigerant oil is circulated throughout the system by the compressor.

Different oils are used in automotive A/C systems, based on the type of refrigerant. Polyalkylene Glycol (PAG) oil is used for R-134a refrigerant.

The three types of PAG oil are:

- PAG-R for rotary compressors
- PAG-S for swash plate compressors
- PAG-F for the FOT system on the V40 and V41 Quest.
- ND-11 for the Hybrid Altima, Hybrid M, and the Leaf

Refer to the service manual for the correct oil for the system you are servicing.

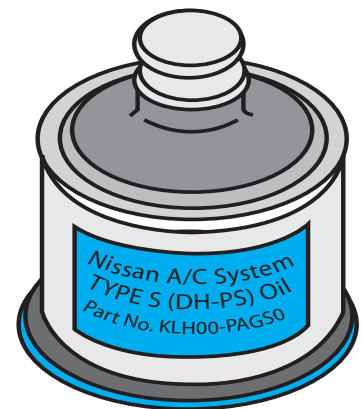

NOTE: PAG oil is very hygroscopic as it absorbs moisture from the atmosphere. PAG oil should be exposed to the atmosphere as little as possible while charging an R134a system.



Malfunctions

Oil contamination, including moisture, can cause system failures. Improper lubrication can cause abnormal wear to the compressor as well as corrosion to other system components.

Different types of refrigerant oil (even PAG oils) are not interchangeable and should never be mixed. Because vehicles with R-12 systems continue coming in for service, it is important to remember that R-12 systems use mineral oil instead of PAG oil. Adding PAG oil to an R-12 system (or vice versa) can cause seal failure and refrigerant leakage.

In old R-12 systems, lines and hoses relied on refrigerant oil to maintain seal integrity and prevent leakage at hose and line fittings. Newer R134a air conditioning systems use barrier-type hoses that are self-sealing and prevent refrigerant leakage with or without refrigerant oil.

Insufficient oil in the system causes compressor failure due to lack of lubrication, but excess oil collects in the condenser and prevent proper cooling performance. When working with the ACR5 AC Service Center or replacing components, make sure to replace the exact amount of oil required. The best way to be certain is draining all the oil from the component, then refill with the amount specified in the service manual.

Diagnosis

If the compressor sounds as though it needs lubricating, it probably does. Check the system for debris, and replace the compressor if needed.

If cooling performance is poor despite several recent repairs, the system may contain excess lubricant, especially if oil was added to the system without draining and measuring all the oil.

Review Questions

1. Fill in the missing answer for the following questions:
2. All Nissan vehicles except the first and second generation _____ front air conditioner use a thermal expansion valve.
3. Refrigerant flow through the evaporator is moderated by feedback from a _____ at the evaporator outlet tube.
4. As the temperature of the evaporator rises, the valve _____ to release more refrigerant.
5. The thermal expansion valve (TXV) uses a _____ restriction to reduce the pressure of the refrigerant and control the volume of refrigerant entering the evaporator.
6. The refrigerant entering the evaporator from the thermal expansion valve is a cold, _____ just starting to _____.

Climate Control Variations

There are two basic types of climate control: manual temperature control (MTC) and automatic temperature control (ATC). Manual controls are self-explanatory and will not be discussed in



detail; however, many of the diagnostic exercises are designed specifically for vehicles with manual climate control systems.

Over the past decade, ATC has progressed from being a luxury item offered only on high-end models to an option available on nearly all models. Understanding how ATC interacts with the other climate control systems is often the key to diagnosing problems. Understanding how HVAC functions also helps verify customer concerns, whether by clarifying the symptoms or demonstrating that the customer misunderstood the normal operation of the system.

Automatic Temperature Control (ATC) Overview

The Automatic Temperature Control (ATC) system is designed to act much like a home thermostat for central heating. It keeps the interior of the vehicle at a set temperature without the customer monitoring the controls or changing the fan speed. In addition to keeping a constant temperature, the system tries to reach the set temperature in the most comfortable manner for the vehicle occupants.

While there are different ways to accomplish these goals, the basic operation of the ATC system is the same for all vehicles. Information on specific models can be found in the Auto Air Description section of the service manual (HA section). Briefly, the unified meter and auto amplifier sends signals to the actuators to control the positions of the air distribution doors and the speed of the blowers, based on input from the temperature sensors.

The five major types of components of the ATC system are blowers, air distribution doors, temperature sensors, microprocessors, and actuators.

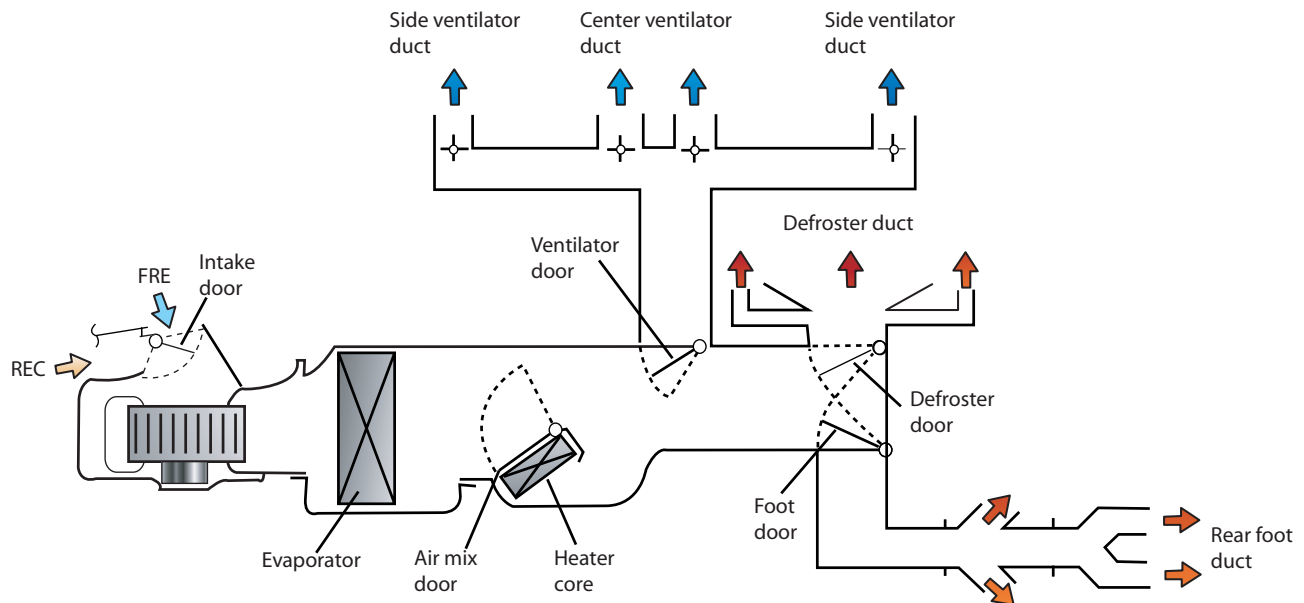

HEATING

The heating system is extremely simple. Hot engine coolant circulates through the heater core; air is blown across the heater core and into the passenger compartment. ATC systems control both the blower speed and the amount of directed through the heater core.

Heater Core

Operation

The heater core is like a small secondary radiator that transfers heat from the engine cooling system into the passenger compartment when warm air is desired. Just like a radiator, it has tubes and fins to transfer heat to the air from the hot engine coolant flowing inside.

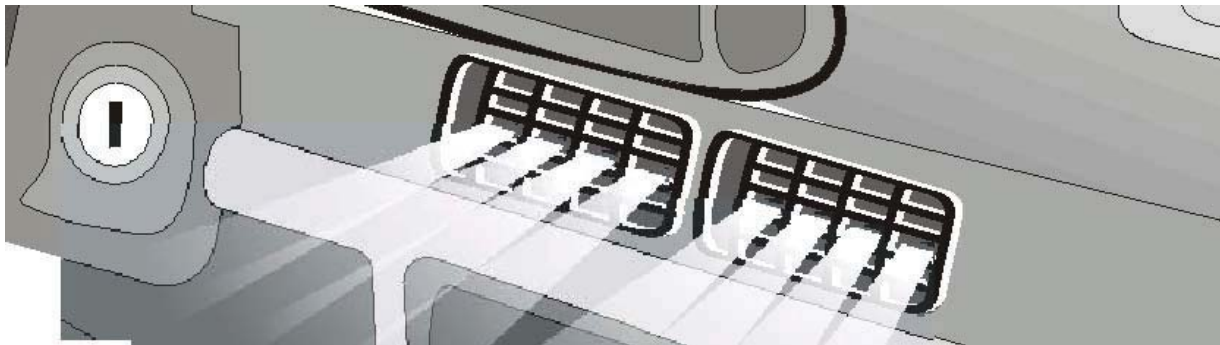

Malfunctions

Optimum heater performance depends on good cooling system performance. If any components of the cooling system are malfunctioning, the operation of the heating system will be affected as well.

Diagnosis

If the heater is slow to reach full temperature, the thermostat may be stuck open, causing the engine to warm up slowly. In addition to a thermostat, certain engines (such as the VQ30DE, VQ35DE, QR25DE, and the VK56DE) also have a water control valve, which prevents coolant flow into the heater core until the engine warms up. A slight delay in heating is normal for vehicles equipped with a water control valve.

Cooling System

Cooling Circuit

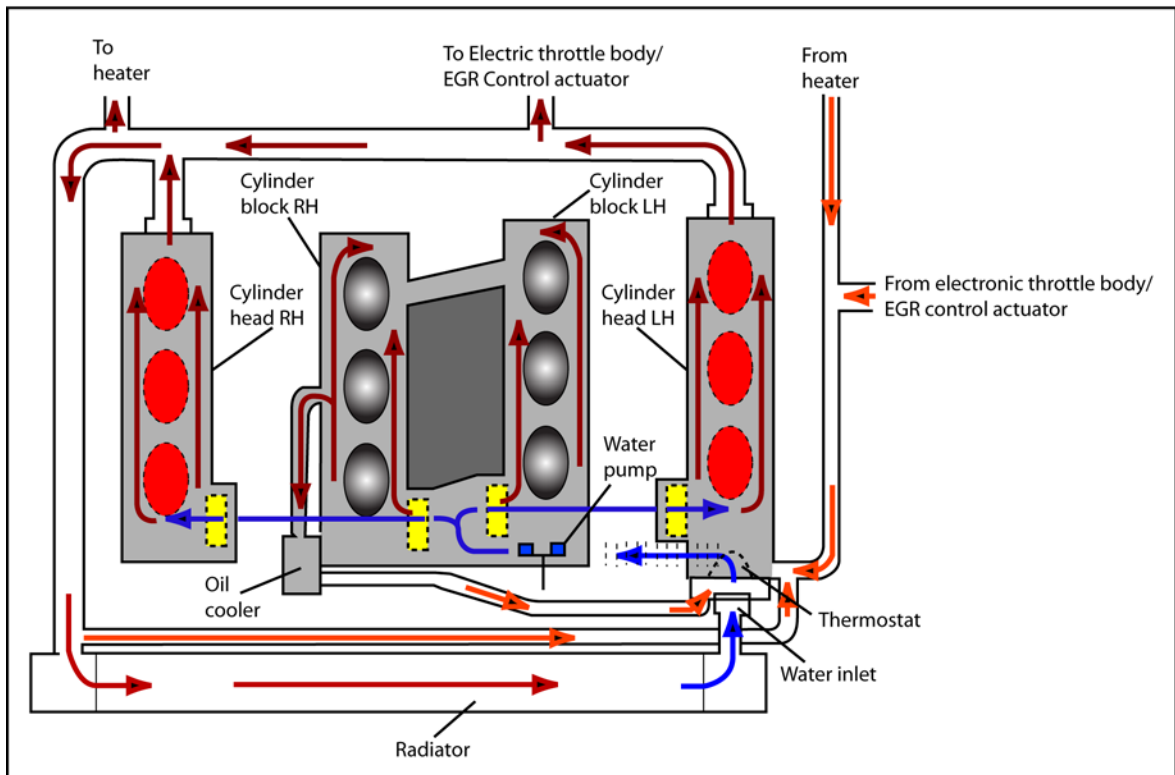

VQ35DE Cooling System

Poor heating performance can also be caused by air in the system. The air will rise to the highest point in the system, which is often the heater core. Using a coolant purging funnel or cooling system refill system is the easiest way to purge air bubbles. Otherwise, you will need to lift the vehicle's front end as much as 18" and suspend the overflow reservoir from the hood to make sure no air is trapped. Certain vehicles have air bleeding points in the cooling system, which simplify cooling system service.

Bleeding the Cooling System Without the Coolant Refill and Bleeding Tool

Refilling the cooling system requires bleeding air from the system during the refill procedure. Use the following procedure as necessary:

1. Remove the air relief plug from either the heater hose or the intake manifold.
2. Fill the radiator and reservoir tank to the specified level.
3. When engine coolant overflows the air relief hole on heater hose or intake manifold, install the air relief plug with clamp.
4. Continue filling the engine coolant.
5. Install radiator and reservoir caps (note correct position).

6. Warm up engine until thermostat opens by varying the engine speed between idle and 4,000 rpm.
7. Stop the engine and allow it to cool down to less than approximately 50° C (122° F).
8. Refill the reservoir tank to "MAX" level line with engine coolant if necessary.
9. Repeat steps 6 - 8 two or more times with reservoir tank cap installed until engine coolant level no longer drops.
10. Check cooling system for leaks.
11. Warm up the engine and check for sound of coolant flow while running the engine from idle to 3,000 rpm while also positioning the heater temperature between hot and cold. If air remains in the system a gurgling sound may be noticeable in the heater core.
12. If a gurgling sound is heard, repeat steps 6 - 11 as necessary.

Cooling System Refill Procedure

When refilling the cooling system with coolant, always use Coolant Refill Tool J-45695. Use of this tool during service or maintenance provides the following benefits:

- Ensures complete filling without trapped air bubbles in the cooling system
- Avoids air pockets in the cooling system which can cause:
 - Overheating
 - Poor heater performance
 - Gurgling noise from the heater core

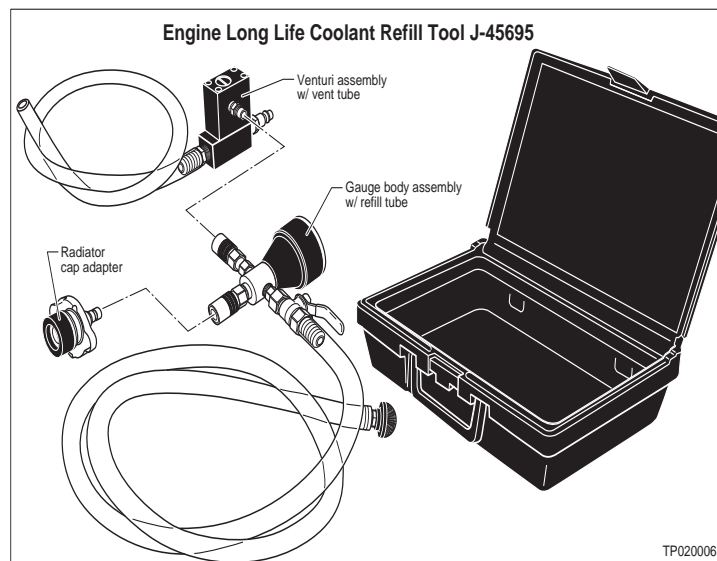

Review Questions

1. The unified meter and auto amplifier in an ATC vehicle controls which of the following components: (Check all that apply)
 - Air distribution doors
 - Blower speed
 - Fresh/Recirc door
 - Fresh/Recirc door**
 - Air mix door
 - Thermal expansion valve



2. Select the most correct answer describing heater cores: (Select one)
 - The heater core is like a small secondary radiator
 - The heater core is similar in design to a condenser
 - The heater core adds heat to the passenger compartment by thermal convection
3. The cooling system refill tool provides which of the following benefits when servicing a cooling system:
 - Ensures complete filling without trapped air bubbles
 - Avoids air pockets in the system
 - Increases the ability of the condenser to remove heat from the refrigerant
 - Improves coolant flow through the cooling system

Engine Coolant Temperature Sensor (Thermal Transmitter)

Operation

The thermal transmitter or engine coolant temperature sensor (ECT) sends coolant temperature information from the coolant passages in the engine to the unified meter and auto amplifier. Until the ECT indicates the engine has reached a specified temperature, the unified meter and auto amplifier will not send a signal for starting fan speed control. This prevents the heater from blowing cold air on the passengers, and helps the engine warm up somewhat faster. Refer to the service manual for each vehicle for wiring diagram information and physical location of the thermal transmitter.

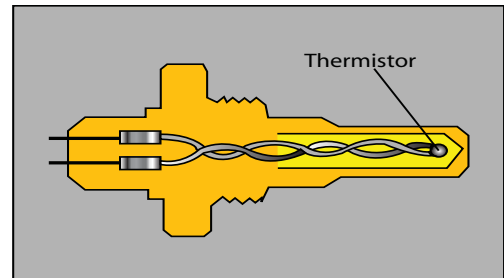

Malfunctions

Since the thermal transmitter is an electrical component, either the part itself or the wires leading to it can be damaged or disconnected. If the thermal transmitter fails, the auto amplifier will be unable to determine the temperature of the heater core and will fail to turn on the heater.

Diagnosis

If the heater fails to operate, the thermal transmitter is a possible cause as it indicates to the ECM, the engine temperature remains low.

Using self-diagnosis, follow the directions in the service manual to find malfunctioning components and rule out other control problems. If the vehicle is CONSULT-III compatible, you should be able to detect a failed ECT using Data Monitor and/or self-diagnosis results.

Heater Pump

Since 2004 on the Quest and 2005 on the Pathfinder, a heater pump for ATC vehicles is used. Located in the engine compartment near the bulkhead is the heater pump. The heater pump only operates when the heater is set to full hot (90° F) and the fan speed is set to high. The pump provides quicker heating to the larger cabin area of the Quest and Pathfinder.

Malfunctions

Anytime a customer has a concern of poor heating performance inspect the heater pump operation. The customer may complain of poor heating with the engine idling.

Diagnosis

Inspect heater pump operation with the controls set to 90° F. Battery voltage is supplied to the pump through the heater pump relay.



Heater Water Valve

Beginning with the 2004 model year, the Armada and QX56 utilize a Heater Water Valve for improving maximum cooling when using the MAX AC setting. The water valve cuts the flow of engine coolant to the front and rear heater cores. This valve is controlled by the front air control unit through the water valve relay. The relay and valve are energized cutting coolant flow anytime MAX A/C is selected. The 2011 QX56 no longer uses the heater water valve for cutting hot water flow into the passenger compartment.

Malfunctions

Insufficient cooling with all AC system pressures correct.

Diagnosis

Inspect for a stuck open Heater Water Valve or a faulty heater valve relay.

Cooling System Electrolysis

In general, cooling system failures result after neglect and/or the use of poor quality coolant. Multiple heater core failures could be the result of high acidity in the cooling system due to electrolysis. If leaks are found in the heater core and no physical damage to the heater core is present, inspect the cooling system for possible electrolysis.



Testing for Electrolysis

Check for voltage in the cooling system by touching the negative contact of a voltmeter to the battery ground or a known good engine ground and place the positive lead in the coolant. Keep the positive lead from touching any metal part of the cooling system or radiator.

1. Determine if the coolant condition is acceptable using the following procedure:
 - b. Record the radio station presets for all channels.
 - c. Remove the negative and positive battery cables from the battery.
 - d. Touch the negative lead of the DMM to an adequate engine ground.
 - e. Set the positive lead of the DMM into the coolant without touching any portion of the radiator housing.
 - f. Check the voltage in the cooling system. If the voltage is less than or equal to 0.4 volts the cooling system acidity is at an acceptable level. If the voltage is greater than 0.4 volts, the cooling system requires flushing.
 - g. Flush the cooling system and refill it with Genuine Nissan Long Life Coolant.



Review Questions

1. The Heater Pump used on the Quest and Pathfinder operate when the climate control temperature is set to what value: (Check one)
 - 75° F.
 - 80° F.
 - 85° F.
 - 90° F.
2. Cooling system electrolysis takes place when the measured voltage in the cooling system is above what voltage value: (Check one)
 - 0.2 Volts
 - 0.3 Volts
 - 0.4 Volts
 - 0.5 Volts

AUTOMATIC TEMPERATURE CONTROL

The Automatic Temperature Control (ATC) system is designed to keep the interior of the vehicle at a set temperature without the customer having to monitor the controls. In addition to keeping the set temperature constant, the system tries to reach the set temperature in the most comfortable manner for the vehicle occupants.

Because the ATC system controls the heating and air conditioning functions, it is important to verify customer complaints to make sure the customer understands how to use ATC most effectively. It is also possible for a malfunctioning ATC system to prevent the system from operating correctly, even though the refrigerant loop is in good working order. You can use self-diagnosis routines and CONSULT to help identify ATC problems.

While there are different ways to monitor the system and maintain a set temperature, the basic operation of the ATC system is the same for all vehicles. Information on specific models can be found in the Auto Air Description section of the service manual (HA section). Regardless of the vehicle, ATC systems use certain components for automatic temperature control.

All ATC systems currently installed in Nissan and Infiniti vehicles use “Dual Zone Automatic Temperature Control”.

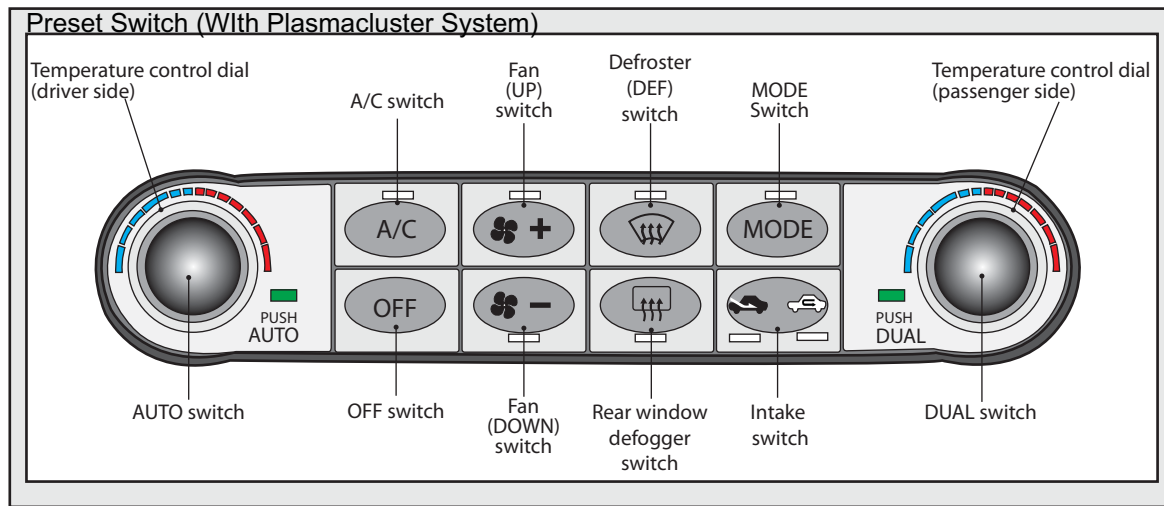

ATC Components

An ATC system needs to monitor the temperature outdoors (ambient sensor), the temperature inside the vehicle (in-vehicle sensor), the temperature of the AC evaporator core (thermal transmitter), and the heat from sunlight shining on the vehicle (sunload sensor). Most ATC systems also monitor the temperature of the air at the evaporator (intake sensor) and the in-vehicle temperature (in-vehicle sensor). The unified meter and auto amplifier translates this input into commands to the motors for the air mix door, mode door, intake door, and the blower in the HVAC module. It also controls the operation of the compressor in fixed-displacement systems and the amount of air passing through the heater core.

Unified Meter and A/C Amplifier

Operation

The unified meter and A/C amplifier regulates air temperature, direction, and air volume using inputs from various sensors and controlling the operation of components. This is similar to how the ECM monitors engine conditions and controls the fuel and exhaust systems. Consult the ser-

vice manual for each vehicle for the wiring diagram and location of the unified meter and A/C amplifier.

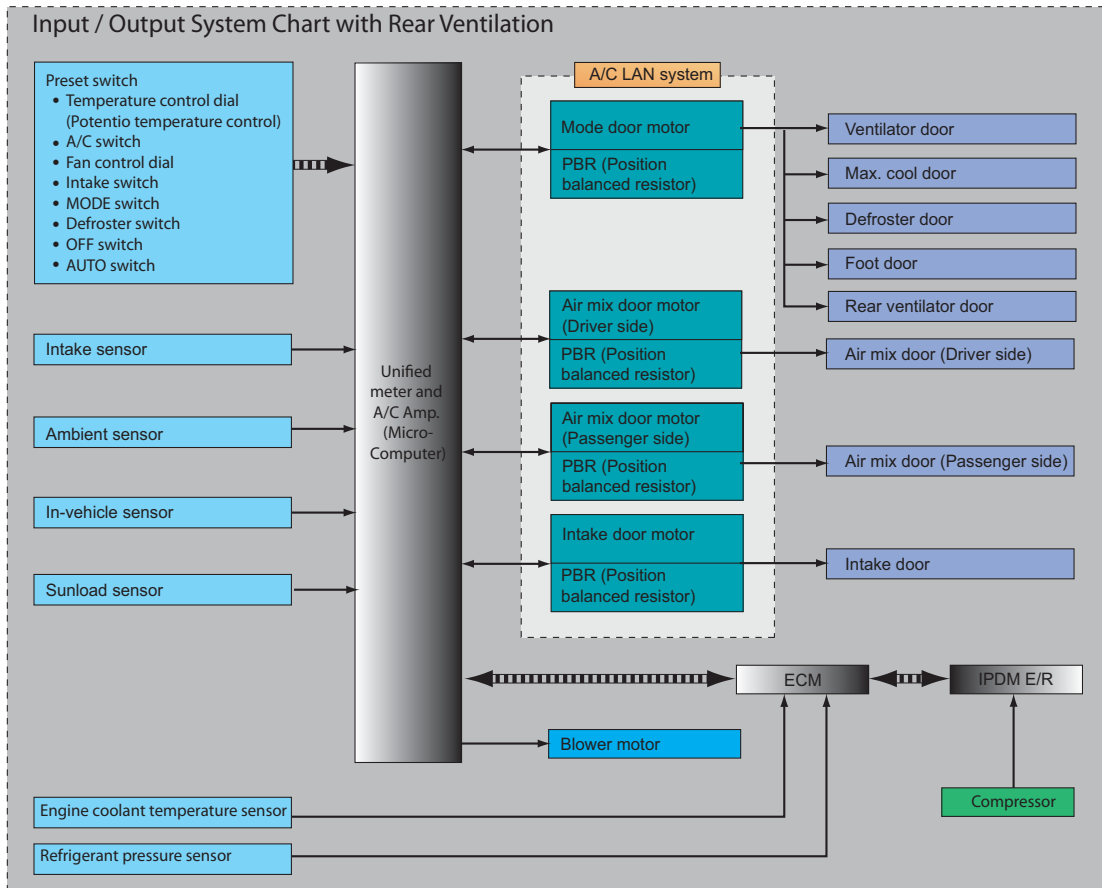

Malfunctions

Since the unified meter and A/C amplifier is a micro-computer, either the component itself or the wires leading to it can be damaged or disconnected. If the unified meter and A/C amplifier fails, the ATC system will not function properly.

Diagnosis

If the system appears to be stuck on defrost, fresh air, and heating, there is a problem with the unified meter and A/C amplifier and/or mode door motor. These are the default settings for safety reasons.

Follow the directions in the service manual for self-diagnosis to find malfunctioning components and rule out other control problems.

Dual Zone Automatic Temperature Control

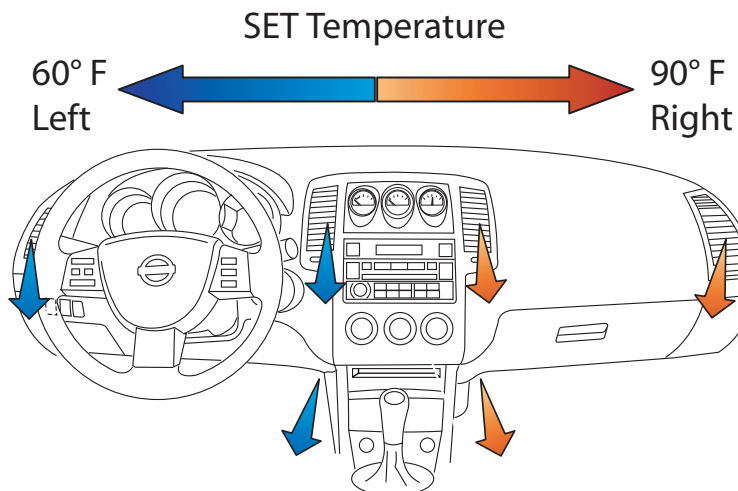
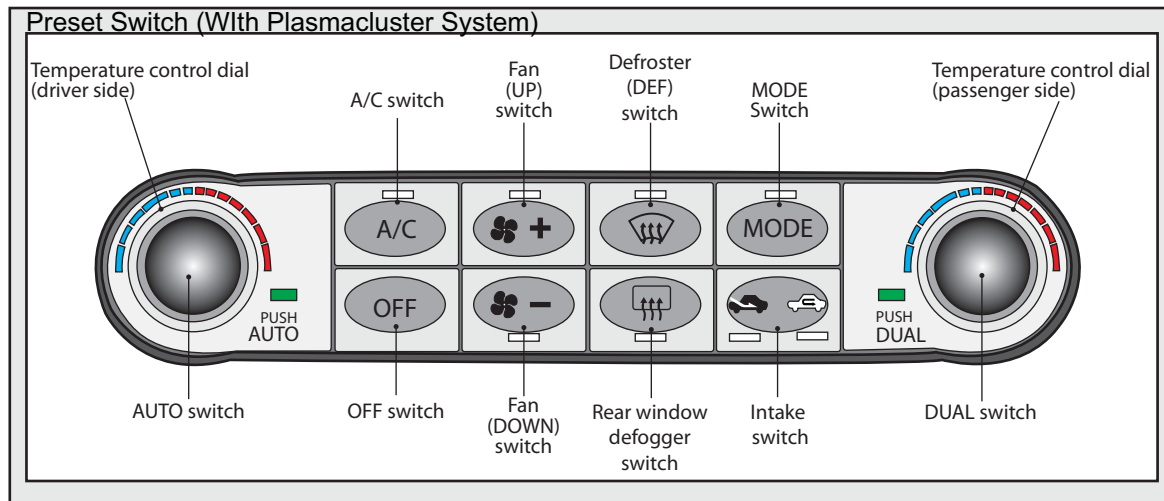

Current vehicles with ATC contain the Dual Zone climate control. This allows the driver and passenger to establish individual temperature settings.

Malfunctions

The driver or passenger temperature settings remain fixed in only one position.

Diagnosis

Inspect the air mix door operation for the faulty side. Use self-diagnosis or CONSULT-III to find malfunctioning components and ruling out other faults.



Fans and Blowers

Operation

Fans and blowers move fresh or recirculated air across the evaporator and heater cores providing cooled or heated air for the climate control system. Without blowers, the refrigerant inside the evaporator would absorb very little of the heat from the passenger compartment. Similarly, the cold air in the passenger compartment would absorb very little of the heat from the hot coolant inside the heater core.

In a vehicle with ATC, the unified meter and auto amplifier sends signals to the fan speed control to determine the speed of the blower, according to the operating conditions.

The blower motor circuit on manual A/C systems uses a fixed or stepped resistor for fan speed control. This type of resistor is commonly used to control electrical motor speeds. By changing the position of the fan switch, resistance is either increased or decreased within the fan circuit. If the current flows through a low resistance, higher current flows through the motor to ground and the blower speed increases. If the fan switch is placed in the low speed position, an additional resistance is added to the ground side of the circuit. Less current flows through the motor to ground which causes it to operate at a lower speed.

Refer to the service manual for each vehicle for the wiring diagram and physical location of the fans, resistors, and blowers.

Malfunctions

Fans and blowers rarely fail. However, there are still a few potential problems:

- Foreign objects may obstruct or damage the blades
- Wiring or controls may fail
- Bearings may wear and fail

Brushless Blower Motors

Some Nissan and Infiniti systems now utilize a brushless blower motor. Brushless motors have the permanent magnets on the rotor and the electromagnets on the stator. The magnet on the blower motor is considered a rotating magnet.

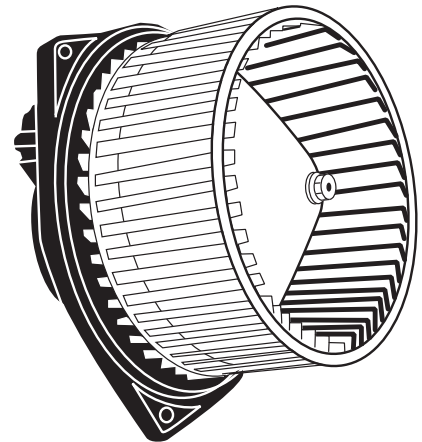
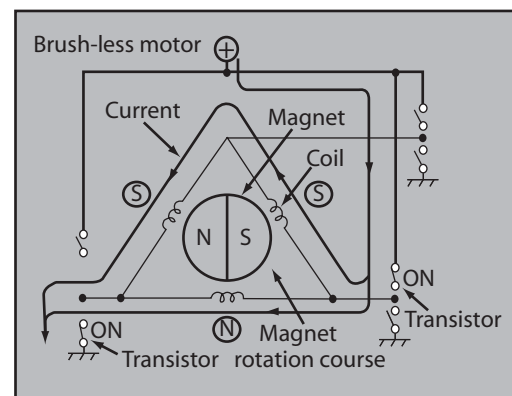

The unified meter and A/C auto amp. controls the motor speed instead of controlling voltage supplied to the mechanical brushes. The unified meter and A/C auto amp. controls the speed of the motor by controlling the duty cycle signal sent to the motor (see illustration to the right). The blower motor speed is calculated by the unified meter and A/C amp. based on input signals from the PBR (Potentio-Ballast-Resistor), in-vehicle sensor, sunload sensor, intake sensor, and ambient sensor. The chart above indicates the duty cycle percentage of ON time for various blower motor settings.

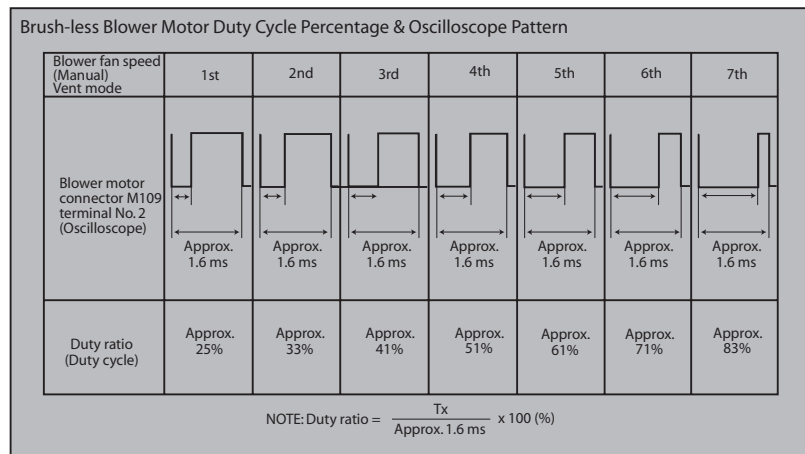

Blower System Diagnosis

A distinctive buzzing or rattling noise from the dashboard area when the fan is running usually indicates leaves, paper, or other debris have fallen inside the blower. Other noises may indicate something more substantial damaged the blades, or the bearings are worn.

If the fan will not operate at all, it is most likely a control or wiring problem. Since fan and blower operation depends on several different controls, failure of any of those components or their wiring will prevent the fan or blower from operating. The fan may also have been disconnected from its power supply or ground.

Using self-diagnosis, follow the directions in the service manual to find malfunctioning components and rule out other control problems.

Fan Speed Control

Operation

Fan speed is based on the difference between the set temperature selected by the customer and the actual temperature of the vehicle interior. If there is a big difference between set temperature and the actual interior temperature, the system switches to a high fan speed. As the interior temperature approaches set temperature the fan speed decreases.

Fan speed also varies to compensate for sunload. On some vehicles, fan speed also varies according to the ambient (outside) temperature. Fan speed can also be manually controlled.

The unified meter and auto amplifier uses the fan speed control to translate its signals into different voltage levels to control the speed of the blower motor. Refer to the service manual for each vehicle for the wiring diagram and physical location of the fan speed control.



Malfunctions

Since the fan speed control is an electrical component, either the part itself or the wires leading to it can be damaged or disconnected. If the fan speed control fails, the blower motor will not turn on.

Diagnosis

If the fan does not operate and the fan switch is good, the fan speed control is a possible cause.

Using self-diagnosis, follow the directions in the service manual to find malfunctioning components and rule out other control problems.

Starting Fan Speed Control

Operation

Automatic Mode

Fan speed is automatically controlled by the temperature setting, ambient temperature, in-vehicle temperature, intake temperature, amount of sunload and air mix door position.

When pressing the AUTO switch, the blower motor gradually increases air flow volume.

When engine coolant temperature is low, the blower motor operation is delayed preventing cool air from flowing into the passenger compartment.

Starting Fan Speed Control - Cold Soak

Start up from COLD SOAK Condition (Automatic mode)

In a cold start up condition where the engine coolant temperature is below 56° C (133° F), the blower does not operate for a short period of time (up to 150 seconds). The exact start delay time varies depending on the ambient and engine coolant temperature. In the most extreme case (very low ambient), the blower start delay is 150 seconds as described above. After this delay, the blower will operate at low speed until the engine coolant temperature rises above 56° C (133° F), and then the fan speed increases to the objective speed.

Start up from usual or HOT SOAK Condition (Automatic mode)

The blower begins operation momentarily after the AUTO switch is pressed. The fan speed increases gradually to the objective speed over a time period of 3 seconds or less (actual time depends on the objective fan speed).

Using CONSULT-III, follow the directions in the service manual to find malfunctioning components and rule out other control problems. If the vehicle is CONSULT-III compatible, you should

be able to detect a failed starting fan speed control using HVAC Data Monitor on CONSULT-III HVAC compatible vehicles and Engine Data Monitor on all models.

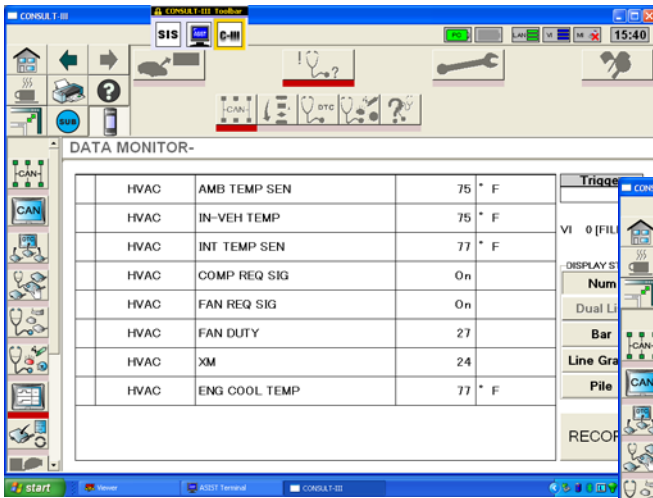

HVAC Data Monitor

Engine Data Monitor



Fan speed Compensation

Sunload

When the in-vehicle temperature and the set temperature are very close, the blower operates at low speed. The low speed varies depending on the sunload. During conditions of low or no sunload, the fan speed is at a duty ratio of 25%. During high sunload conditions, the unified meter and A/C amp. increase the fan speed duty ratio to 49%.

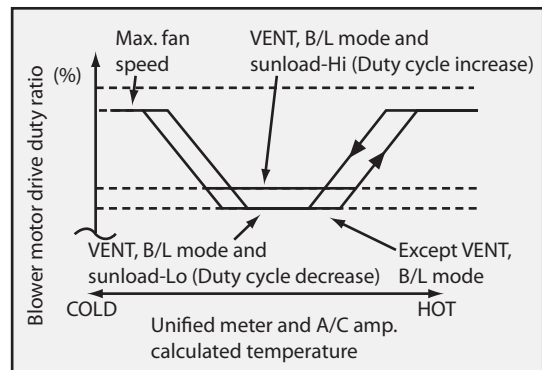

Fan Control

Operation

An ATC system typically runs the blower at a faster speed when the difference between the set temperature and the in-vehicle temperature is greater. In other words, the fan blows fastest when the ATC is trying to cool down a hot car or warm up a cold one. When the system is merely maintaining the set temperature, it slows down the blower, which also allows the system to operate more quietly. The IC circuit in the blower

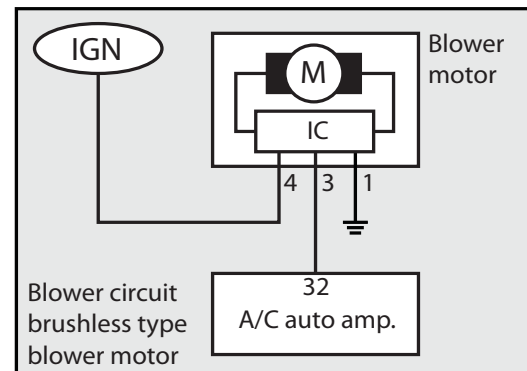

assembly or fan control amplifier controls fan speed in response to signals from the unified meter and A/C auto amplifier or front air control. Refer to the service manual for each vehicle for the wiring diagram and physical location of the fan control amplifier.

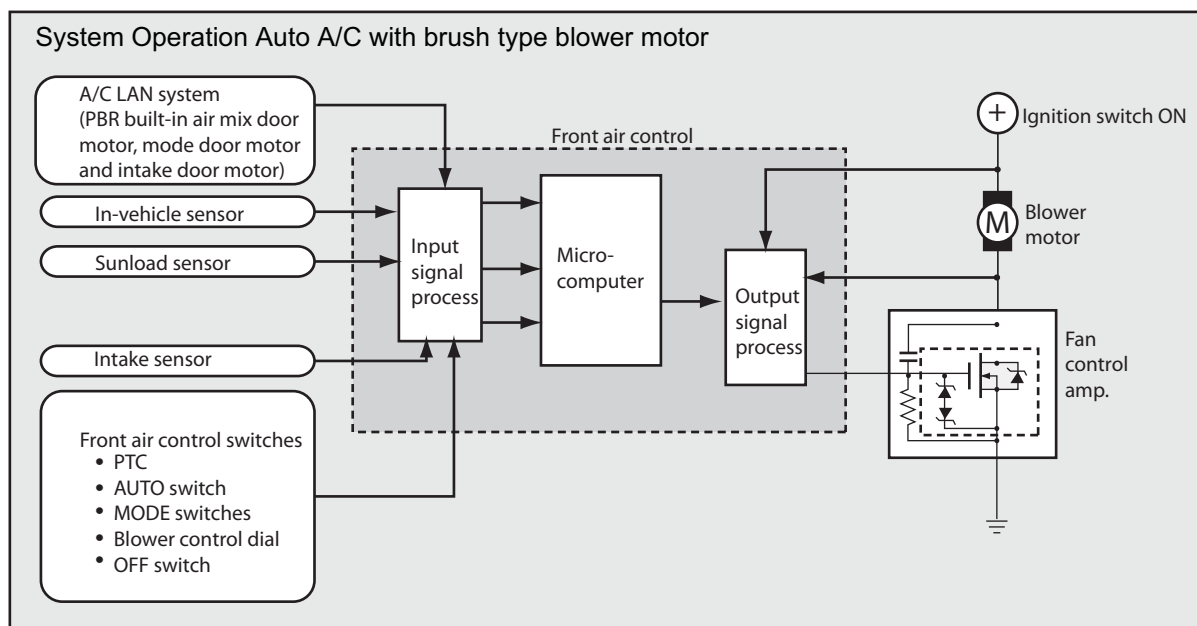

Malfunctions

Since the IC circuit in the blower motor or fan control amplifier is a microprocessor, either the component itself or the wires leading to it can be damaged or disconnected. Power surges or physical impacts can damage it. If the fan control amplifier fails, the ATC system will be unable to operate the blower and no air will flow from the ducts.

Diagnosis

If the fan does not operate, a failed fan control amplifier is one of the possible causes.

Using self-diagnosis, follow directions in the service manual to find malfunctioning components and rule out other control problems.

Review Questions

1. Which of the following statements best describes brushless blower motors: (Check all that apply)
 - Brushless motors have the permanent magnets on the stator
 - The magnet on the blower motor is considered a rotating magnet
 - The unified meter and A/C auto amp controls blower speed by controlling duty cycle
 - All of the above

2. When the engine coolant temperature is below 56° C (133° F), the blower does not operate for what period of time: (Check one)
 - Up to 120 seconds
 - Up to 130 seconds
 - Up to 140 seconds
 - Up to 150 seconds

3. Under vehicle hot soak conditions, the blower does not operate for what period of time: (Check one)
 - 1 second or less
 - 2 seconds or less
 - 3 seconds or less
 - 4 seconds or less

In-vehicle Sensor

The in-vehicle sensor sends passenger compartment temperature information to the unified meter and auto amplifier or front air control assembly. The sensor is located on the instrument panel near the drivers side. The sensor converts variations of in vehicle temperature into a resistance value which is input into the unified meter and A/C amplifier. The sensor utilizes an aspirator for drawing air across the thermistor by creating a low or negative pressure from the blower fan. The in-vehicle sensor provides in-vehicle temperature information for controlling passenger compartment temperatures to the specified value set on the AC controls. The sensor is a negative coefficient thermistor (NCT) or sometimes referred to as a Non-Linear Thermistor (NLT). For these types of sensors, when the temperature increases the resistance decreases.

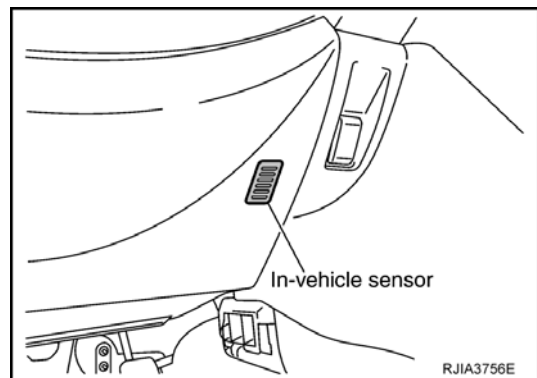

Refer to the service manual for each vehicle for the wiring diagram and physical location of the in-vehicle sensor.

Malfunctions

Since the in-vehicle sensor is an electrical component, either the part itself or the wires leading to it can be damaged or disconnected. If the in-vehicle sensor fails, the ATC system will be



unable to determine whether the in-vehicle temperature has reached the set temperature, and it will keep heating or cooling.

Diagnosis

If the ATC will not stop heating or cooling at the set temperature, the in-vehicle sensor is a possible cause.

Using self-diagnosis follow the directions in the service manual to find malfunctioning components and rule out other control problems.

Compressor Clutch Control

Operation

In vehicles without variable-displacement compressors, the compressor clutch is ON any time the ATC system is in the automatic or defrost modes unless the ambient temperature is too low (approximately 35° F). The compressor is OFF in the economy mode; however, the ATC will try obtaining the set temperature without the compressor. Refer to the service manual for each vehicle for the wiring diagram and physical location of the compressor clutch control.

Malfunctions

Since the compressor clutch control is an electrical component, either the part itself or the wires leading to it can be damaged or disconnected. If the compressor clutch control fails, the compressor will not cycle ON. This will also occur if either the auto amplifier or the ATC receives an improper signal.

Diagnosis

If the compressor does not cycle ON the compressor clutch control is a possible cause.

Using self-diagnosis, follow the directions in the service manual to find malfunctioning components and rule out other control problems.

All Nissan and Infiniti vehicles are CONSULT-III compatible. This allows technicians to view signals which indicate AC compressor operation, fan operation, AC pressure sensor, and AC ON signal operation. Information is located in both HVAC and engine for AC operation.

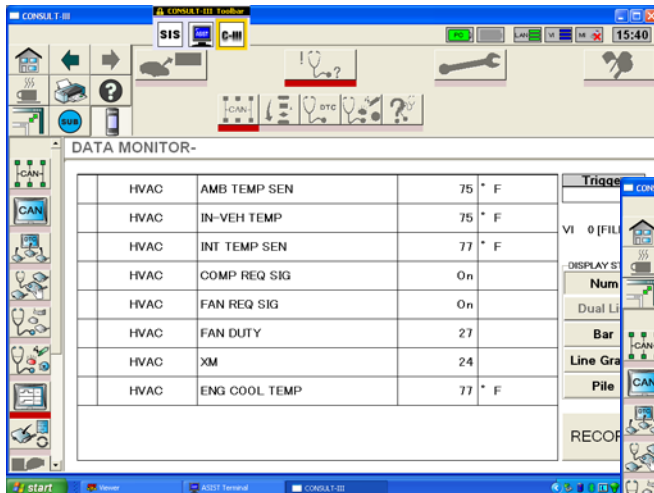

HVAC Data Monitor

Engine Data Monitor

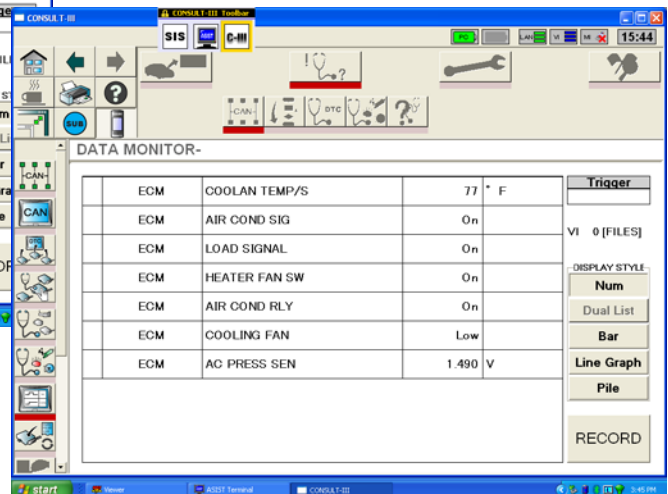

Using CONSULT-III in ENGINE rather than HVAC enables you to quickly view the AC pressure sensor values. A low or high pressure sensor voltage value will disable the AC Compressor Magnet Clutch due to it being an input to the ECM. The ECM via a signal from the A/C auto amplifier activates or disables the AC Relay in the IPDM E/R dependant upon input voltage signals.

Ambient Sensor

Operation

The ambient sensor sends outside air temperature information to the unified meter and A/C amplifier. It is located just inside the vehicle's grill, in front of the condenser. The sensor is a negative coefficient thermistor (NCT) or sometimes referred to as a Non-Linear Thermistor (NLT). For these types of sensors, when the temperature increases the resistance decreases.

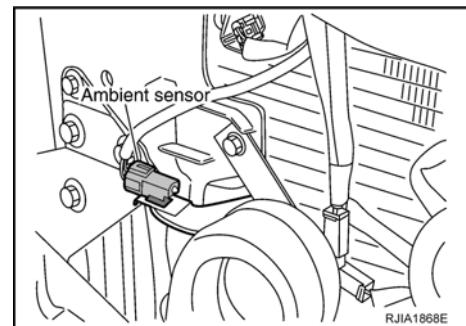

Ambient Temperature Input Process

The automatic amplifier includes a processing circuit for the ambient sensor input. However, when the temperature detected by the ambient sensor increases quickly, the processing circuit retards the front air control function. It only allows the front air control to recognize an ambient



temperature increase of 0.33° C (0.6° F) per 100 seconds. As an example, consider stopping for a cup of coffee after high speed driving. Although the actual ambient temperature has not changed, the temperature detected by the ambient sensor will increase. This is because the heat from the engine compartment can radiate to the front grille area, location of the ambient sensor.

Refer to the service manual for each vehicle for the wiring diagram and physical location of the ambient sensor.

Malfunctions

Since the ambient sensor is an electrical component, either the component itself or the wires leading to it can be damaged or disconnected. Since it is located at the front of the engine compartment, it is subject to more severe conditions than the sensors located inside the passenger compartment. If the ambient sensor fails, the ATC system will be unable to determine the outside temperature and the air conditioner may not cycle on. If the circuit is open, this signal will be interpreted as a very low temperature. The unified meter and A/C amplifier will not send a signal to turn on the compressor.

Diagnosis

If the air conditioner will not blow cold even though touch and feel diagnosis shows the refrigerant loop is functioning properly, the ambient sensor is a possible cause.

Using self-diagnosis, follow the directions in the service manual to find malfunctioning components and rule out other control problems.

Sunload Sensor

Operation

The Sunload sensor measures the amount of sunlight entering the vehicle and sends this information to the unified meter and A/C auto amplifier. The Sunload is detected by means of a UV Photo Diode or a Non-Linear Photo Resistor. The Sunload sensor converts the Sunload into a current value which is then input into the unified meter and A/C auto amplifier. The sensor is located on the dashboard near the windshield.

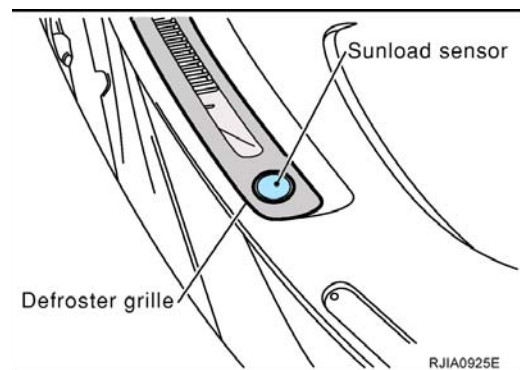

Sunload Input Process

The front air control also includes a processing circuit which averages the variations in detected sunload over a period of time. This prevents drastic swings in the automatic temperature control system operation due to small or quick variations in detected sunload. For example, consider driving along a road bordered by an occasional group of large trees. The sunload detected by the sunload sensor varies whenever trees obstruct the sunlight. The processing circuit averages the detected sunlight over a period of time, so the (insignificant) effect of the trees momentarily obstructing the sunlight does not cause any change in the automatic temperature control system operation. On the other hand, shortly after entering a long tunnel, the system recognizes the change in sunload, and the system reacts accordingly.

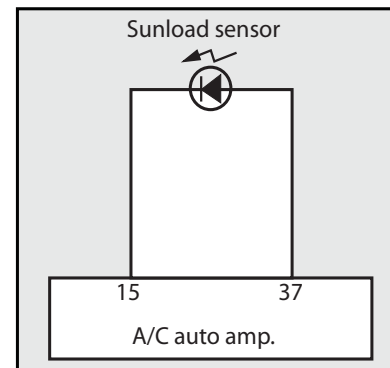

Refer to the service manual for each vehicle for the wiring diagram and physical location of the Sunload sensor.

Malfunctions

Since the Sunload sensor is an electrical component, either the part itself or the wires leading to it can be damaged or disconnected. If the Sunload sensor fails, the ATC system will be unable to determine whether or not sunlight is warming the passenger compartment, and will not cool the car sufficiently on hot, sunny days.

Diagnosis

If the air conditioner is not cold enough on hot, sunny days, the Sunload sensor is a possible cause.

Using self-diagnosis, follow directions in the service manual to find malfunctioning components and rule out other control problems.



Intake Sensor

Operation

All current Nissan and Infiniti vehicles use an intake sensor attached to the evaporator to send evaporator intake air temperature information to the A/C amp. or unified meter and A/C amplifier. The intake sensor is located on the heater and cooling unit. The sensor determines evaporator and intake air temperature. The sensor is a negative temperature coefficient (NTC) thermistor which changes resistance value depending upon temperature. The sensor converts temperature of air after it passes through the evaporator into a resistance value which is then input to the front air control or unified meter and A/C auto amplifier. The intake temperature sensor provides a means for controlling compressor stroke or operation depending upon evaporator and intake air temperature.

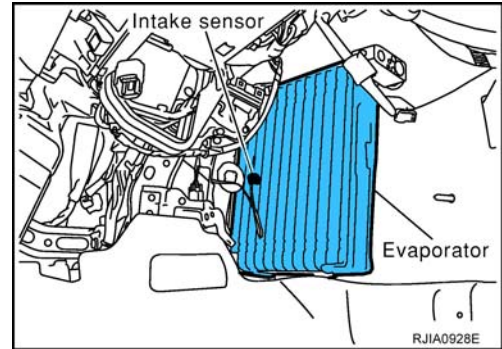

Refer to the service manual for each vehicle for the wiring diagram and physical location of the intake sensor.

High In-Vehicle Temperature Starting Control

On ATC vehicles when the evaporator fin temperature is high after a hot soak condition [intake sensor value exceeds a specified amount depending upon vehicle application], to prevent hot discharged air flow into the passenger compartment, the A/C auto amp. suspends front blower motor activation for approximately 3 seconds so the front evaporator is cooled by refrigerant.

Low Temperature Protection Control

When the intake sensor detects the front evaporator fin temperature is below a specified value (depending upon vehicle), the A/C amp. requests the ECM turn the compressor OFF.

- When the front evaporator fin temperature returns to a specified value, the compressor clutch engages from a signal provided by the ECM and A/C amp. or A/C Auto Amp.

Temperature vs. Resistance

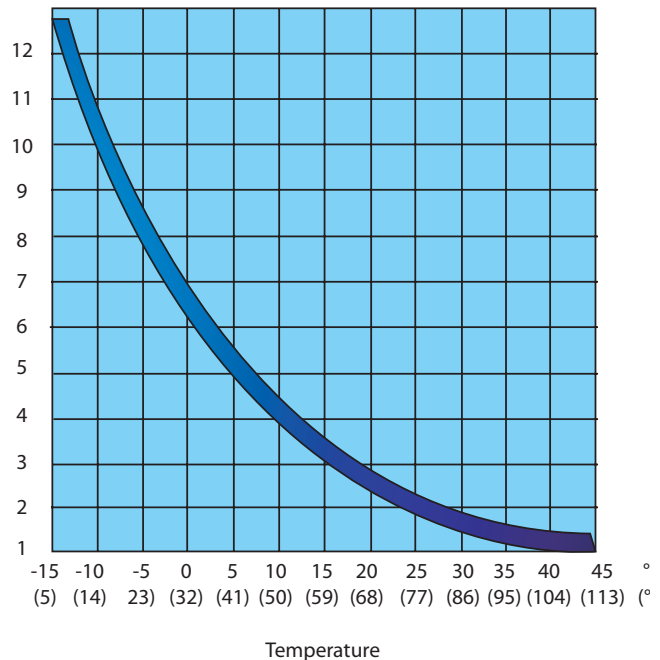

Malfunctions

Since the intake sensor is an electrical component, either the part itself or the wires leading to it can be damaged or disconnected. If the intake sensor fails, the ATC system will be unable to determine the evaporator is working and the air conditioner will not cycle on or off as expected.

Diagnosis

When the intake sensor fails, it appears to be an open circuit. This is interpreted by the system as a signal that the evaporator or intake air temperature is too cold, and the compressor is turned off. Using self-diagnosis follow directions in the service manual to find malfunctioning components and rule out other control problems.

Refrigerant Pressure Sensor

Operation

The refrigerant pressure sensor attaches to the condenser or liquid tank. The sensor protects against excessively high or low refrigerant pressures. If the pressure rises above or below specification, the refrigerant pressure sensor sends a voltage signal to the ECM indicating high or low pressure in the refrigerant system. The ECM then ceases to supply power to the A/C relay which disengages and stops the compressor when pressure on the high pressure side (as detected by refrigerant pressure sensor).

Malfunctions

The sensor could stay at a specific voltage or go above or below the specification causing the AC compressor magnet clutch to be inoperative.

Diagnosis

Voltage for the refrigerant pressure sensor can be viewed using CONSULT-III under ENGINE.

Review Questions

- The in-vehicle sensor, intake sensor, and ambient sensor are referred to as which type of thermistors: (Check one)
 - Positive coefficient thermistor
 - Negative coefficient thermistor
 - Linear thermistor
 - Upscale thermistor

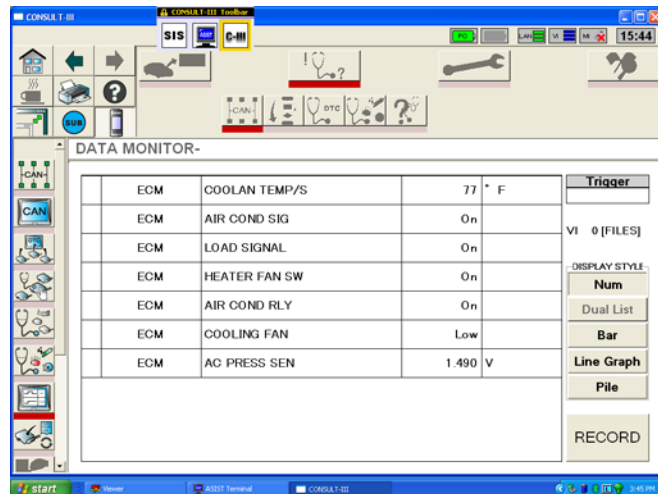

Engine Data Monitor

2. The sunload sensor is referred to as which type of resistor: (Check one)
 - UV Photo diode or Non-linear photo resistor
 - UV Photo diode or linear photo resistor
 - UVB Non-linear photo resistor
 - Photo linear resistor

3. The refrigerant pressure sensor attaches to which components: (Check one)
 - Compressor or high pressure line to condenser
 - Receiver dryer or condenser
 - Low pressure line between evaporator and compressor
 - High pressure line between condenser and receiver dryer

Air Mix Door and Motor

Operation

The air mix door position is controlled by the unified meter and auto amplifier and ATC, based on input from the various input sensors. The position of the air mix door directs cold air, hot air or a mixture of cold and hot air into the passenger compartment to bring the interior temperature to the set temperature. Refer to the service manual for each vehicle for the wiring diagram and physical location of the air mix door motor.

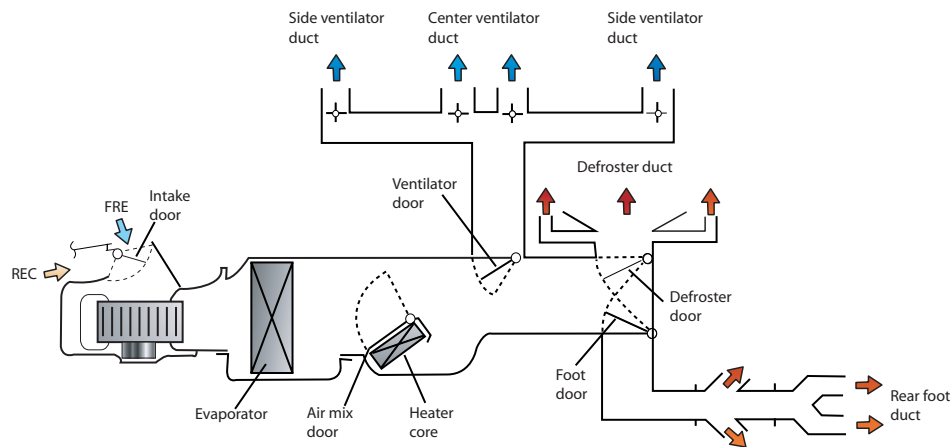

Malfunctions

The control rod to the air mix door can get dislodged or mis-adjusted, or the air mix door motor can fail. Also, the switch on the control panel or the connection to the auto amplifier can be damaged.

Diagnosis

If the air mix door is stuck in the cold air position there will be no heating and possibly cold air blowing. If the air mix door is stuck in the hot air position, there would be no cooling and most likely hot or warm air blowing instead. If the door is stuck midway, the air will always be warm rather than hot or cold as appropriate.

If the air mix is stuck on hot, the mode is stuck on defrost, and the intake is stuck on fresh air, check the unified meter and auto amplifier.

Using self-diagnosis, follow the directions in the service manual to find malfunctioning components and rule out other control problems.

Mode Door

Operation

The mode door controls the direction and distribution of discharge air according to the set temperature. If the discharge air is hot, the mode door directs air to the foot vents. If discharge air is cool, discharge air is generally directed to the face vents. Discharge air that is the same temperature as the set temperature is distributed in the bi-level (face and foot) mode. Refer to the service manual for each vehicle for the wiring diagram and physical location of the mode door motor.

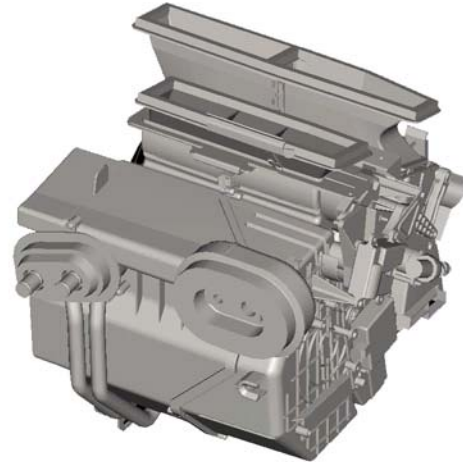

Malfunctions

The control rod to the mode door can get dislodged or mis-adjusted, or the mode door motor can fail. Also, the switch on the control panel or the connection to the auto amplifier can be damaged.

Diagnosis

If air is coming out of the wrong vents, there is a problem with the mode door, its motor, the controls or any potential adjustments.

If the mode is stuck on defrost, the air mix is stuck on hot, and the intake is stuck on fresh air, check the unified meter and auto amplifier.

Automatic Temperature Control Using self-diagnosis, follow directions in the service manual to find malfunctioning components and rule out other control problems.

Potential Balance Resistor (PBR)

Operation

Potential Balance Resistors (PBR) send door position information to the unified meter and A/C amplifier. One PBR is located in the air mix door motor and another is located in the mode door motor. Refer to the service manual for each vehicle for the wiring diagram and physical location of each PBR.

Malfunctions

Since the PBR is an electrical component, either the part itself or the wires leading to it can be damaged or disconnected. If the PBR fails, the ATC system will position the air mix doors incorrectly, and therefore the desired air mixture and temperature will be incorrect.

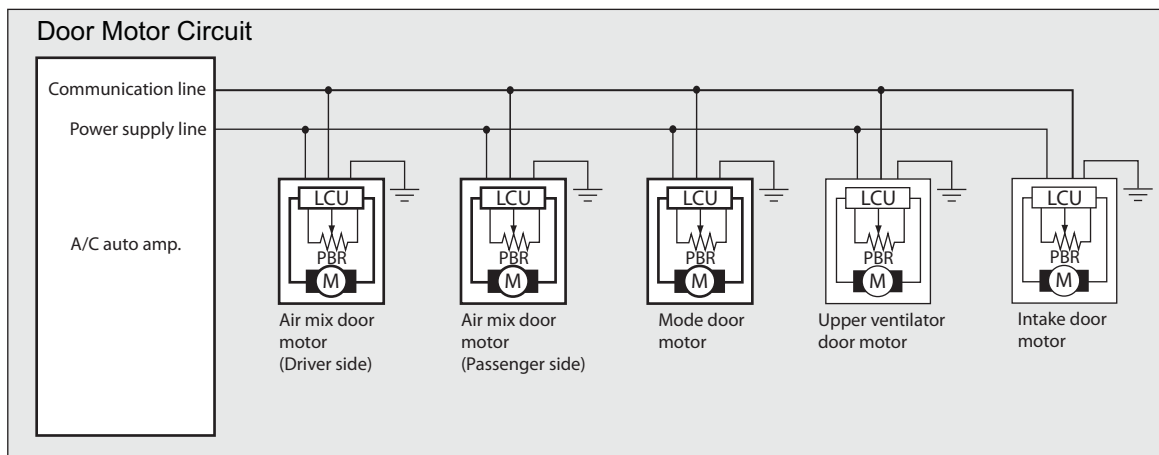
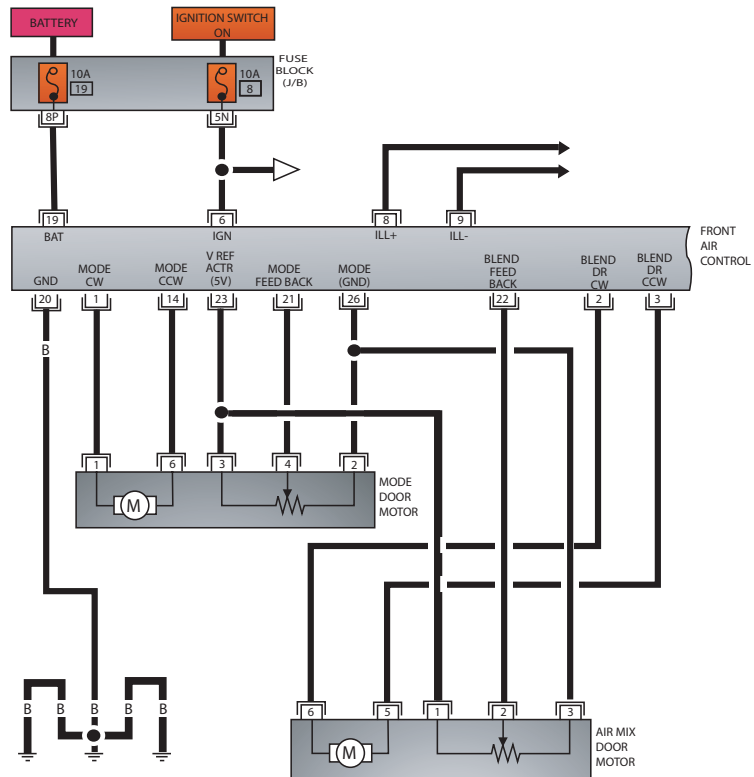



Diagnosis

If the air temperature from the vents is not the expected temperature, or the air exits the incorrect position, the PBR is a possible cause.

If the vehicle has self-diagnosis, follow the directions in the service manual to find malfunctioning components and rule out other control problems. If the vehicle is CONSULT-III compatible, you should be able to detect a failed PBR using Self-Diagnosis. Other vehicles are diagnosed using manual self-diagnosis.

Review Questions

1. The air mix door motor performs which of the following functions: (Check one)
 - Changes the outlet air passage between, feet, face, and defrost
 - Changes the intake air between fresh and recirc or a combination of fresh and recirc
 - Increase blower speed under hot or cold soak conditions
 - Directs hot or cold air into the passenger compartment

2. The Potentio Balance Resistor (PBR) provides which of the following information to the unified meter and A/C amplifier during climate control operation: (Check one)
 - Door position
 - Blower fan speed and operation
 - Engine cooling fan operation
 - Evaporator temperature

M37/56 CONSULT-III Settings

The M37/M56 has features not found on any other Nissan or Infiniti product as of this publication date. The following table provides an overview of those items and changes that can be performed using CONSULT-III.

Temperature Set Correct, REC Memory Set, and FRE Memory Set can also be adjusted on other models such as the Murano and Maxima climate control systems using CONSULT-III.

CONSULT-III Item	Notation
Temp Set Correct	If the temperature felt by the customer differs from the actual air flow temperature controlled by the temperature setting, the A/C auto amp. control temperature can be adjusted to compensate for temperature setting
REC Memory Set	Controls the memory for intake air "Recirculation". When set to "Without" the system requires manual ON/OFF control of intake air recirculation. When set to "With", the climate control system automatically controls the intake air between Fresh and Recirculate.



CONSULT-III Item	Notation
FRE Memory Set	Controls the memory for intake air "Fresh". When set to "Without" the system requires manual ON/OFF control of Fresh intake air. The default setting remains in the FRESH position. When set to "With", the climate control system automatically controls the intake air between Fresh and Recirculate.
Blow Set	Modifies the customers preference for air distribution out the defroster door/vent. System uses Mode 1 - 4. Mode 1 is the default and provides automatic air through the defrost vent or manual control regarding closing the vent.
Aroma Setting (Not currently used in U.S. Market) (Forest Air)	Provides the ability to change the Forest Air settings between Normal, Weak and Strong. Normal is the initial setting where strong releases a larger amount of Forest Air into the passenger compartment.
Fragrance Setting (Not currently used in U.S. Market) (Forest Air)	Modifies the Forest Air released into the passenger compartment by releasing either one fragrance, A Fragrant Wood or B Leaf Scent. A = Fragrant Wood; B = Leaf Scent; A + B combined.
Blower Motor Setting (Not currently used in U.S. Market) (Forest Air)	Changes the amount of air increase when interior odors are detected. Normal = No air flow increase; Increase (initial setting) = Air flow increases slightly when interior odors detected.
Aroma Diffuser Setting (Not currently used in U.S. Market)) (Forest Air)	Changes the diffuser from With and Without. With = aroma diffuser available; Without = aroma diffuser set to the off position.



QX56 CONSULT-III Settings

Like the M37/56, the QX56 incorporates features into the climate control system not found on all Nissan and Infiniti vehicles. Some features such as Temperature Set Correct, REC Memory Set, and FRE Memory Set can also be adjusted on other models such as the Murano and Maxima climate control systems using CONSULT-III. Always consult the ESM when determining if any of these features are incorporated into a Nissan or Infiniti vehicle.

Manual Diagnosis Item	Notation
Temp Set Correct	If the temperature felt by the customer differs from the actual air flow temperature controlled by the temperature setting, the A/C auto amp. control temperature can be adjusted to compensate for temperature setting
REC Memory Set	Controls the memory for intake air "Recirculation". When set to "Without" the system requires manual ON/OFF control of intake air recirculation. When set to "With", the climate control system automatically controls the intake air between Fresh and Recirculate.
FRE Memory Set	Controls the memory for intake air "Fresh". When set to "Without" the system requires manual ON/OFF control of Fresh intake air. The default setting remains in the FRESH position. When set to "With", the climate control system automatically controls the intake air between Fresh and Recirculate.
Blow Set	Modifies the customers preference for air distribution out the defroster door/vent. System uses Mode 1 - 4. Mode 1 is the default and provides automatic air through the defrost vent or manual control regarding closing the vent.
Gas Sensor Adjustment	Changes the intake fresh/recirculation sensitivity depending upon customer preference. Less sensitive ranges from +2 to most sensitive -2.
Clean SW Set	Controls the interlocking of the AC switch and the auto intake switch. The initial setting enables synchronization between the AC switch and the auto intake so the auto intake automatically is ON when the AC is ON. Setting 1 - Auto intake functions even with AC OFF Setting 2 - When the AC is OFF, the auto intake is OFF Setting 3 - Auto intake can only be turned ON when the AC is ON
Rear Temp Set Correct	If the rear AC temperature felt by the customer differs from the actual air flow temperature controlled by the temperature setting, the A/C auto amp. control temperature can be adjusted to compensate for temperature setting



Advanced Climate Control System (ACCS)

All Infiniti and some Nissan models now use the Advanced Climate Control System (ACCS). This enhances the dual zone automatic temperature control system which has been in use for a number of years. The system includes on most models standard rear console-mounted vents, rear floor heat ducts, and a cabin air micro filter. Interior air temperature can also be set manually using the instrument panel controls. Desired climate settings on some models can be linked to individual Intelligent Keys (I-Key).

Auto Recirculation Control - Exterior Odor Sensor

ACCS includes an automatic recirculation control function that automatically switches from fresh air to recirculated air when the emission gas sensor detects levels of certain gasses. The sensor is located behind the front grille. When the automatic air control is ON, and the sensor detects odors and exhaust gas, the system automatically changes from the outside air mode to the recirculation mode.

For the first 40 seconds on vehicles equipped with Forest Air™, recirculation mode is selected preventing dust, dirt, and pollen from entering the vehicle, while the system cleans the air inside with Plasmacluster™ ions emitted from the vents. After 40 seconds, the outside odor and exhaust gas sensor activates and automatically alternates between the recirculation mode and outside air circulation mode.

The outside odor and exhaust gas detection sensor detects industry odors such as pulp or chemicals, and exhaust gas such as gasoline or diesel.

Forest Air™

The M37/56 is the first Infiniti vehicle to use the Forest Air™ feature. The Forest Air™ feature provides a refreshing breeze-like flow of a natural forest setting in the cabin. The system senses pollution and unpleasant odors in outside air, and automatically opens and closes air intake ducts to reduce their concentration in the cabin. The special grape polyphenol filter and Plasmacluster™ air purifier help filter out allergens, dust, and mold.

Inside Air Quality Sensor

Forest Air™ equipped vehicles include an inside air quality sensor, located under the lower dash panel. When the sensor detects food or tobacco odors in the cabin, the system increases the fan speed automatically. When the Forest Air™ system is ON, the inside air quality sensor turns ON. The Outside/Inside Air Mix function turns OFF when the air recirculation and outside air circulation modes are changed manually. When the Outside/Inside Air Mix function is not active, and the Forest Air™ system is turned OFF and ON, the Outside/Inside Air Mix function activates again.

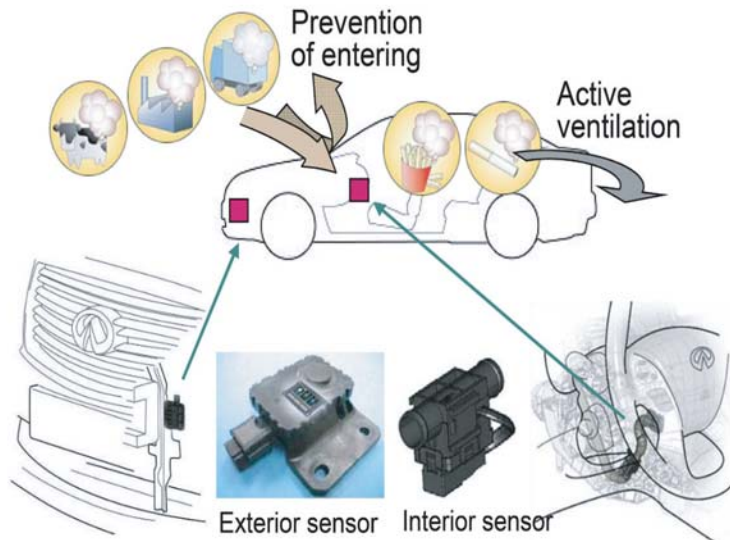

Electric Air Conditioning (A/C) System

The air conditioning system on the Altima Hybrid uses an electric compressor. Like electric power steering, the electric air conditioning compressor shaft turns only when air conditioning is requested. This eliminates the drag of belt and pulleys improving overall economy. AC controls for the hybrid are the same as those found on a conventional Altima.

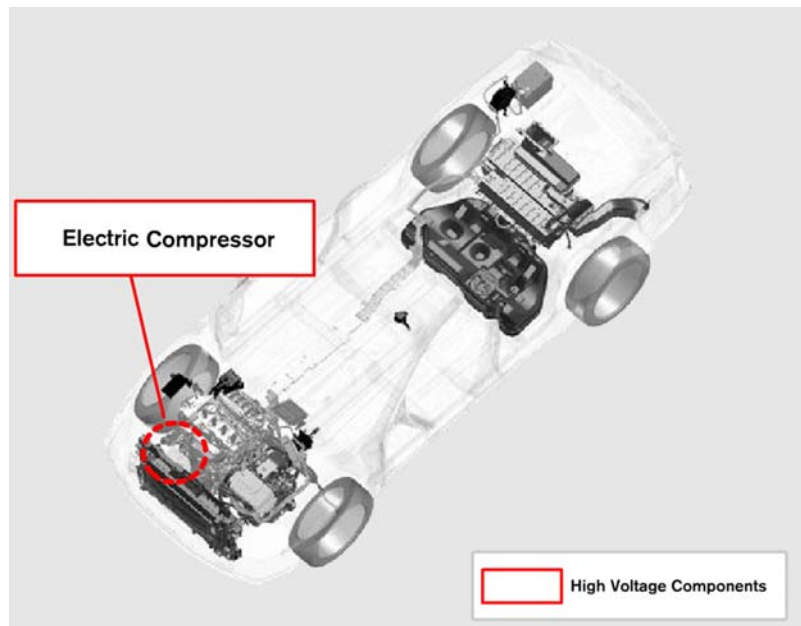



The engine cooling system radiator and air conditioning system condenser are manufactured as a one-piece assembly.

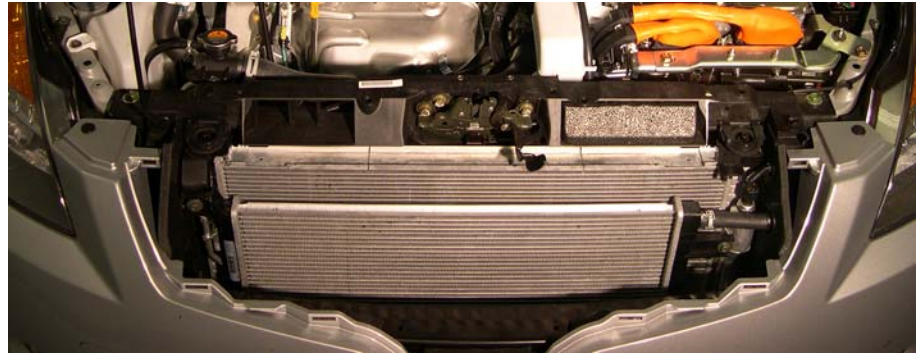

Electric Compressor

The electric compressor is a fixed-displacement scroll-type compressor mounted in a conventional location on the internal combustion engine (ICE). The compressor is not mechanically driven by the engine, but is electrically driven by an electric motor.

The inverter converts the 244.8-volt (Altima Hybrid), 360 volt (Leaf) direct current (DC) from the HV battery to three-phase alternating current (AC) to run the compressor's electric motor. The inverter is built into the compressor.

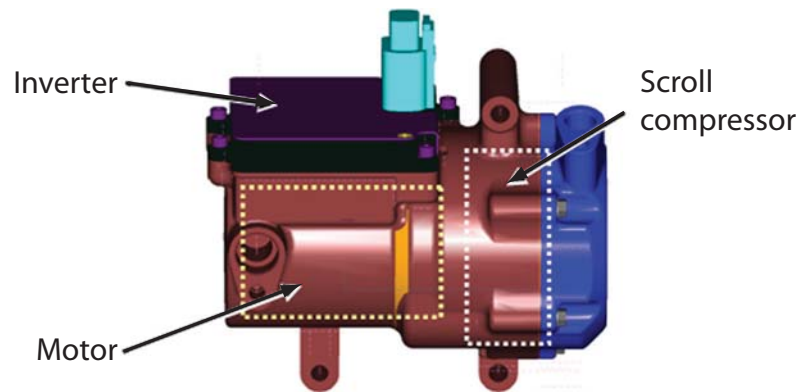

Scroll Compressor Operation

Unlike compressors with reciprocating pistons, the scroll compressor has two spiral scrolls. One scroll does not move, and the second scroll oscillates or "orbits" to pump the refrigerant between the blades of the scroll. The orbiting scroll is driven by the compressor crankshaft. The orbiting motion creates a series of moving cavities between the two scrolls. The orbiting motion creates a series of gas pockets traveling between the two

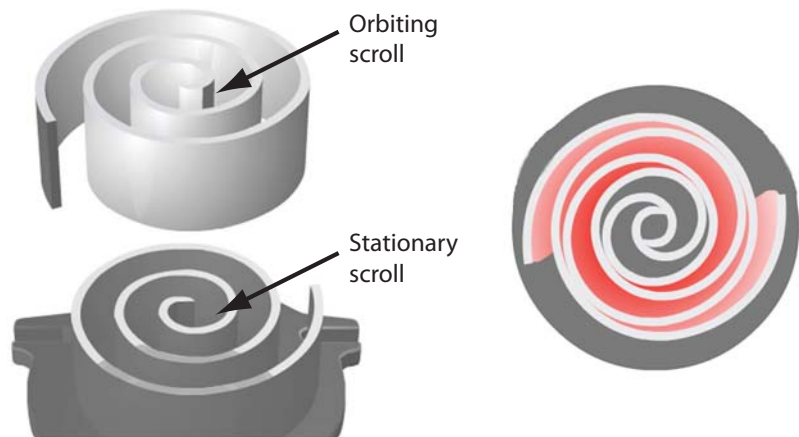

scrolls. As the gas being pumped is moved inward, gas temperature and pressure are increased. On the outer portion of the scroll the pocket draw in gas, then move it to center of the scroll where it's discharged. As the gas moves in the increasing smaller inner pocket, the temperature and pressure increase to the desired discharged pressure.

Refrigerant and Refrigerant Oil Electric Compressor

The electric compressor requires special high-dielectric (high-insulation) refrigerant oil. Always use ND-OIL 11 refrigerant oil in these systems. The air conditioning system uses the same R-134a refrigerant used in all Nissan vehicles. Refer to the ESM for specific service information.

AIR CONDITIONER NISSAN		
	REFRIGERANT	COMPRESSOR LUBRICANT
TYPE (PART NO.)	HFC 134a (R134a)	ND-OIL11
AMOUNT	0.50 ± 0.025 kg (1.10 ± 0.055 lbs)	120 ml (4.06 fl oz)
<p>CAUTION PRECAUTION</p> <ul style="list-style-type: none"> • REFRIGERANT UNDER HIGH PRESSURE. • SYSTEM TO BE SERVICED BY QUALIFIED PERSONNEL. • IMPROPER SERVICE METHODS MAY CAUSE PERSONAL INJURY. • CONSULT SERVICE MANUAL. • THIS AIR CONDITIONER SYSTEM COMPLIES WITH SAE J-639. <p>Nissan Motor Corporation in USA, Carson, CA 27090 JA800</p>		

Electric Compressor Service

Before servicing the electric compressor, remove the Service Disconnect Switch (SDSW) and disable the high voltage system. Perform the high voltage safety tests as described in the Altima Hybrid New Technology training materials and ESM for specific service information.



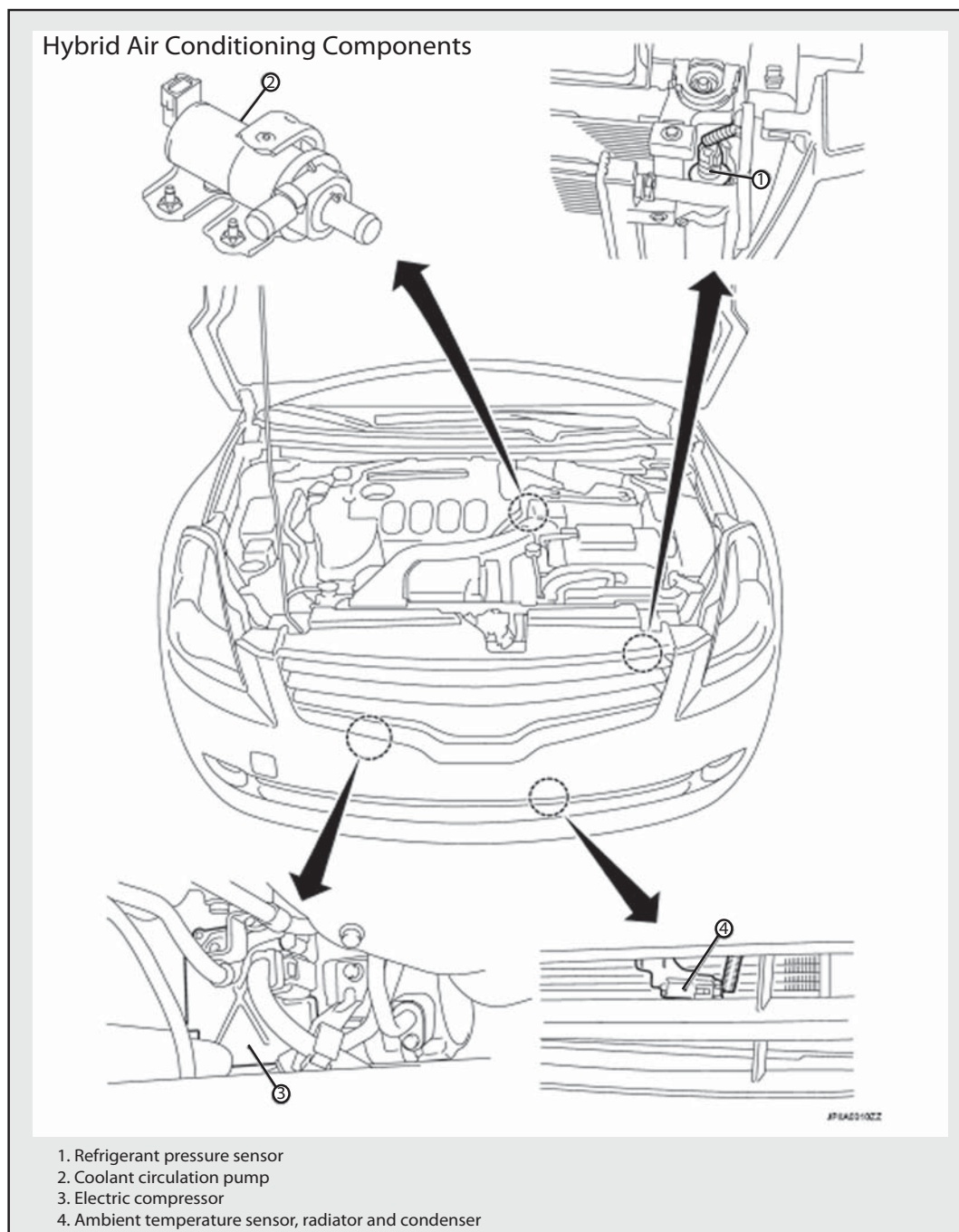

CAUTION: Leak detection dye is not present in the hybrid A/C system. Its use is not recommended for installation in the Hybrid AC system at any time. The dye reduces the dielectric properties of the refrigerant. Use other methods to check for leaks. Refer to the Altima Hybrid ESM for specific service information.

Review Questions

- The Altima Hybrid uses which type of compressor: (Check one)
 - Swash plate
 - Rotary
 - Electric scroll type
 - Piston type
- The scroll type compressor uses how many scrolls for circulating refrigerant in the AC system: (Check one)
 - One scroll
 - Two scrolls
 - Three scrolls
 - Four scrolls
- The scroll type AC compressor requires the use of which type of PAG oil: (Check one)
 - PAG-R
 - PAG-S
 - PAG-F
 - ND-OIL 11

LEAF HVAC and PTC Heater

Because the LEAF does not have an Internal Combustion Engine (ICE), there are key differences in its heating, ventilation, and cooling (HVAC) systems. The following diagram highlights key features of the LEAF HVAC system.

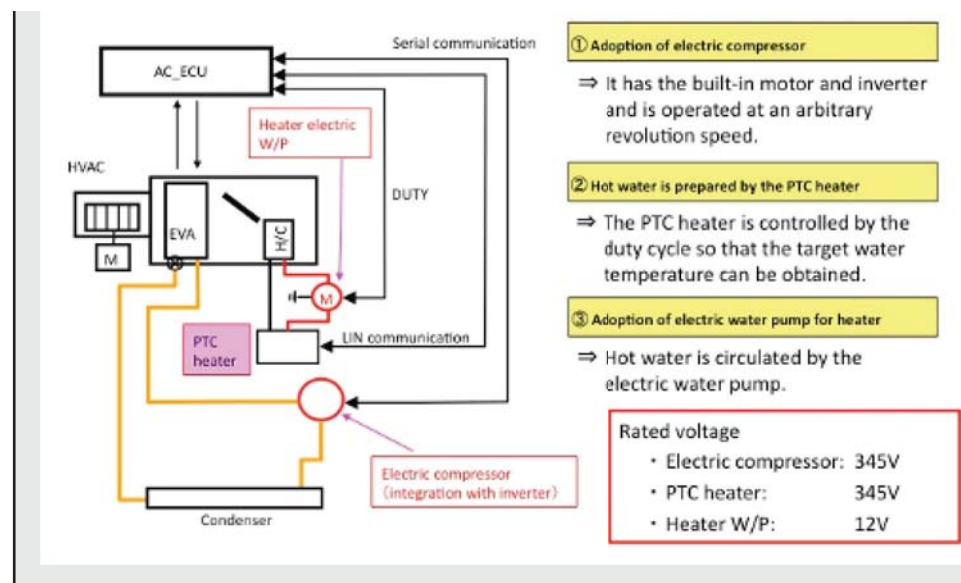

① Adoption of electric compressor
 ⇒ It has the built-in motor and inverter and is operated at an arbitrary revolution speed.

② Hot water is prepared by the PTC heater
 ⇒ The PTC heater is controlled by the duty cycle so that the target water temperature can be obtained.

③ Adoption of electric water pump for heater
 ⇒ Hot water is circulated by the electric water pump.

Electric Compressor

Without an engine driving the compressor, the LEAF doesn't need a drive belt. It uses a 4.6 kW electric compressor for the air conditioner.

- The compressor mounts to the drive motor with a bracket.
- A guard affixed to the compressor protects high-voltage.
- The compressor design is a scroll type that exerts capacity with high revolution speed.
- Capacity = 28 cc/rev, revolution speed = 1500 to 8300 rpm.
- Compressor weight is approximately 14.6 lb. (6.6 kg), similar to a conventional compressor.

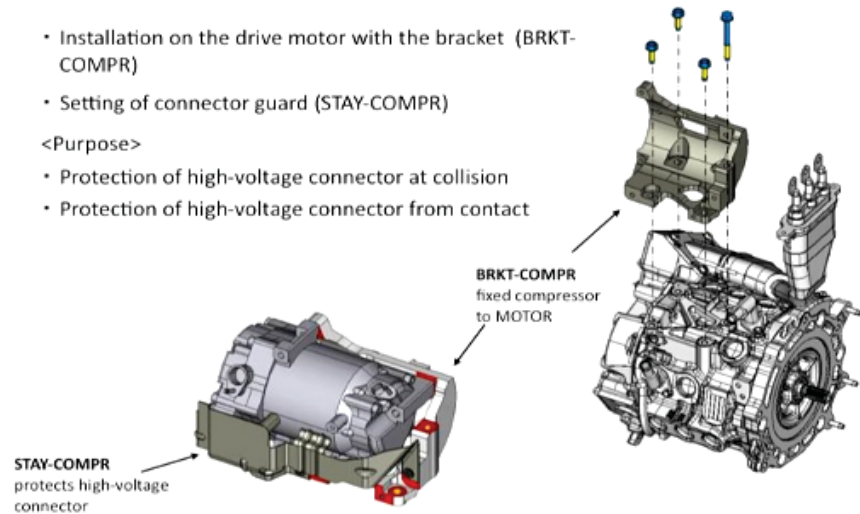

Refrigerant Loop

The refrigerant loop used in the LEAF is similar to the system used in the Altima Hybrid and other vehicles.

- The refrigerant flows through the electric compressor, then the condenser with liquid tank, through the evaporator and back to the compressor.
- The system uses R134a refrigerant, the same as conventional Nissan and Infiniti systems.
- Because of the high voltage used to operate the compressor, a special lubricant must be used in the refrigeration system; Nissan A/C System Oil ND-OIL 11.
- ND-OIL 11 cannot be mixed with other refrigerant lubricants.

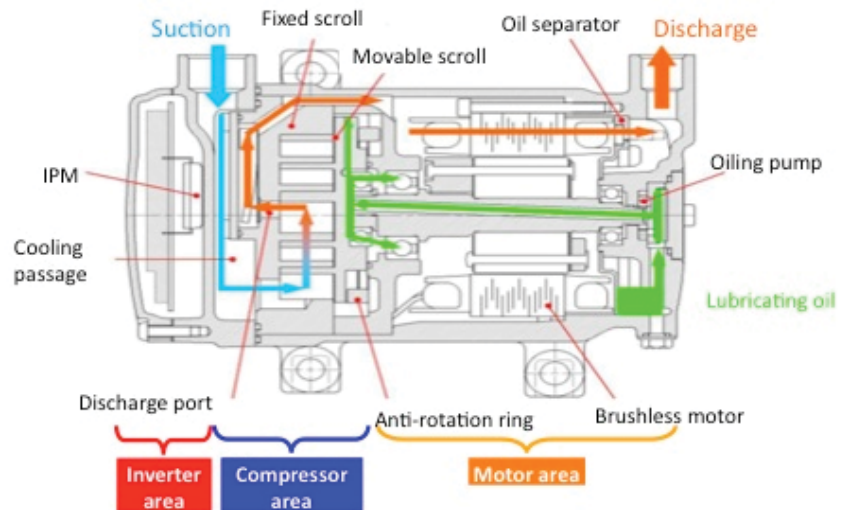

- Only service equipment dedicated for use on high voltage A/C systems should be used for recovery and recharging of the refrigerant used in the LEAF.
- DO NOT USE fluorescent leak detection dye in the refrigerant system.

LEAF High Voltage Heater System

The heating system used in the LEAF is a Positive Thermal Coefficient (PTC) system. With a PTC heating element, the resistance value increases rapidly with the ignition ON and heater operating. With this system, the heating element begins heating up and at the same time, the resistance increases. This differs from our NTC sensors where the resistance increases when the temperature decreases.

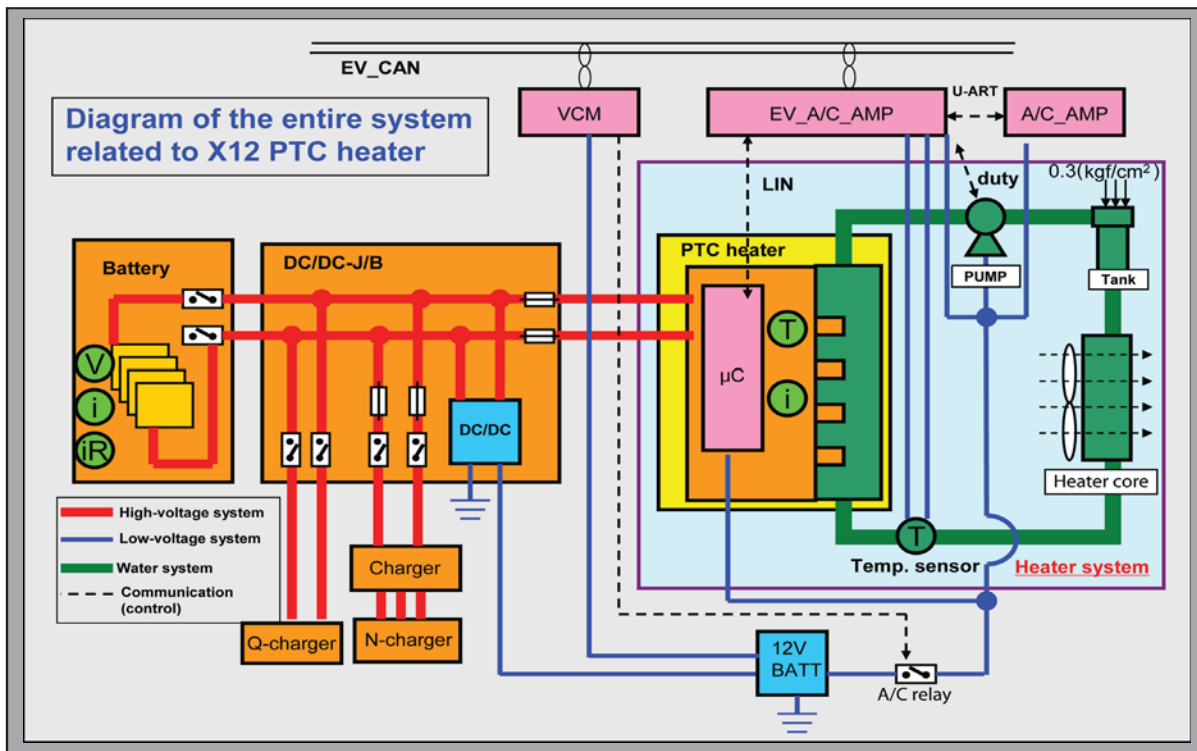

The water pump is a 12-volt duty cycle type pump. This allows increases in flow as needed by increasing the ON time of the pump or decreasing the OFF time and limiting the amount of coolant flow into the passenger compartment. The above graphic identifies the high and low voltage power lines.



Positive Thermal Coefficient (PTC) Heater

The power train in the LEAF doesn't generate as much heat energy as an internal combustion engine. This makes the system a poor source of heat energy to warm the vehicle's cabin.

- To generate heat energy, the LEAF's automatic climate control system has a second, separate fluid circuit, similar to the power train cooling system.
- The PTC heater system is filled with a 50% solution of Super Long Life Coolant (LLC) and demineralized or distilled water.
- An electric heater had been added to the climate control system, located in the motor compartment.
- It's a high performance 5 kW unit called a Positive Thermal Coefficient (PTC) heater; a set of four resistors enclosed in a housing.
- The heating system fluid passes through this housing as electric current passes through the four resistors.
- This generates heat and adds heating energy to the fluid, which is then carried into the cabin and used to heat the vehicles interior.
- The PTC heater system is fully self-contained and is not serviceable individually.
- The PTC heater is a high voltage heater system and requires caution when servicing.
- Compared to an internal combustion engine, the heat source is extremely small.
- The PTC heater activates after turning the ignition ON.
- The PTC heater is duty cycle controlled so the target water temperature is determined by the interior control setting.
- When starting the vehicle, the system is at a high duty cycle ON time for rapid water temperature increase and passenger compartment warming.
- The system is not pressurized as the coolant never increases over 158° F.
- The overflow tank allows the system to bleed any air from the system, while the coolant circulates through the heater core.

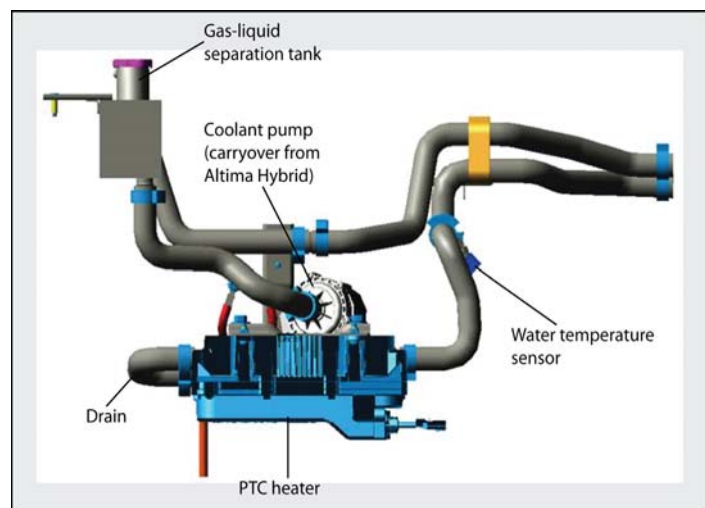
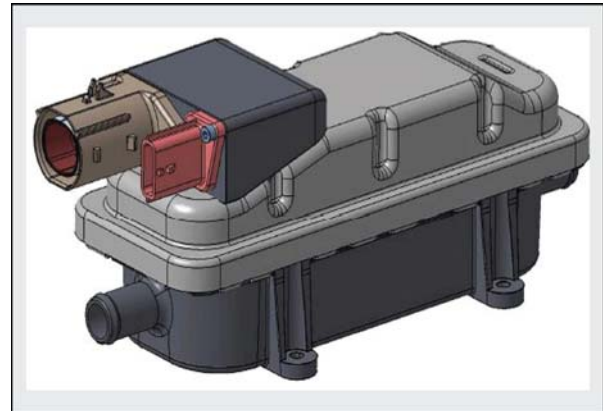

LEAF HVAC Pre-Conditioning

During driving, the climate control system is powered by the high-voltage battery. With all the electric components in the system, the drain on power can reduce the effective driving range.

- To reduce the amount of energy used when driving, the climate control system has a “pre-conditioning” function.
- The cabin can be heated or cooled, in preparation for driving, while the vehicle is connected to a charging source.
- This reserves more of the battery for driving.

The driver can set pre-conditioning with the timer or by remote activation.

- The cabin can be pre-conditioned for up to two hours if the LEAF is connected to a charger.
- It will pre-condition for up to 15-minutes if the vehicle is not connected to a charger.
- The climate control system operates similar to a standard system for automatic climate control or manual settings.



LEAF Pre-Conditioning Monitoring

The driver can monitor the charging and pre-conditioning, by computer, or with a web-enabled smart phone.

Review Questions

1. The LEAF electric vehicle heating system is which type: (Check one)
 - Negative Temperature Coefficient
 - Subzero Thermal Coefficient
 - Mid-range Thermister Coefficient
 - Positive Thermal Coefficient

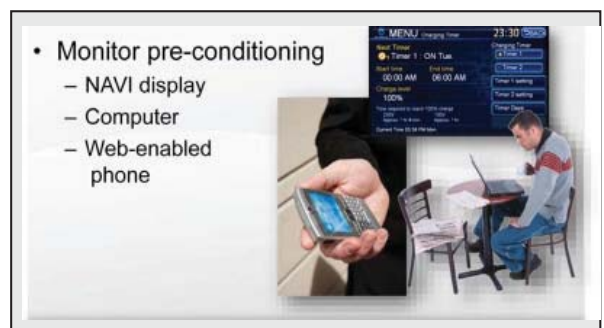



2. The driver of a LEAF can pre-condition (operate) the heating or cooling system for up to two hours when which of the following occurs: (Check one)
 - The vehicle battery has been charged for more than 8-hours
 - While the vehicle is plugged into a charging station
 - After driving the vehicle for 15 minutes
 - When the 12-volt battery is fully charged
3. The heating system requires using which type of coolant: (Check one)
 - 50% solution of Super Long Life Coolant (LLC)
 - 50% solution of Super Long Life Coolant (LLC)**
 - 60/40 solution of Long Life Coolant (LLC)
 - 70/30 solution of Long Life Coolant (LLC)
 - 50/50 ethylene glycol anti-freeze

Air Conditioning Service Ports

Operation

Service ports are pressure fittings for hose and gauge connections, and the only legal or safe openings in the air conditioning system. Each type of refrigerant, R-12 or R134a has its own type of service port to prevent accidental cross-contamination. Service ports are located in the low and high pressure refrigerant lines. You will use service ports to connect the manifold gauge set and the ACR5 AC Service Center when you are diagnosing and servicing the refrigerant loop. The service caps on a R134a system also act as the seal for the service fitting. The valve

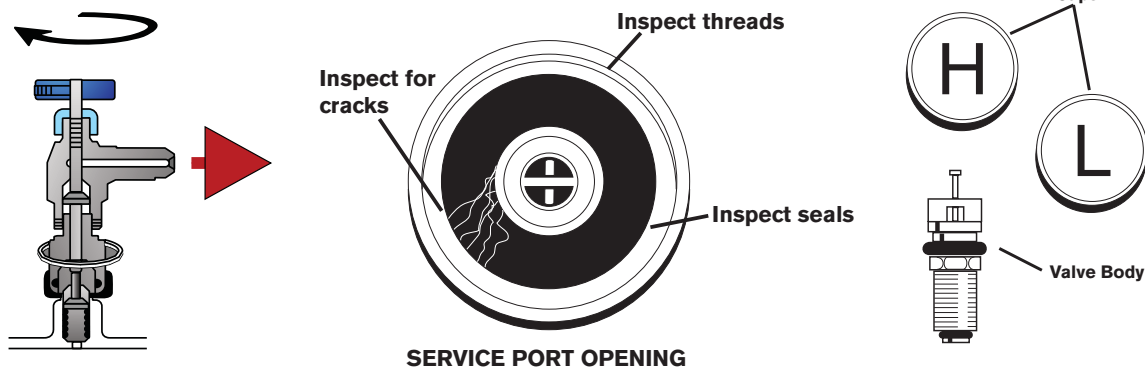

body on R134a systems is not the seal. Systems with missing caps will leak refrigerant.

Service port couplers close by rotating counter-clockwise. **Never connect quick couplers with their valves open or the engine running.**

Unlike previous systems, the valve body is not just a sealing point and the cap is not just for keeping out dust. Due to the molecular size of R134a, the sealing cap is the sealing point, not the valve body. Service ports should always have sealing caps installed to prevent leakage to the atmosphere.

Malfunctions

Service ports rarely fail, but make sure the valve stems and threads are not worn, and the sealing caps are in good condition.

Diagnosis

Always inspect the sealing caps for cracks, worn seals, or damaged threads. Check for refrigerant leaks if you see oil or fluorescent leak detection dye in or around the service port.

Seals and O-Rings

Operation

Refrigerant seals and O-rings are made of special synthetic materials that keep refrigerant and oil in and contamination out. Seals and O-rings fit between refrigerant components, fittings, and lines to form the sealing points in the system.

Nissan and Infiniti vehicles use a type of refrigerant connection improving sealing characteristics and preventing damage during installation. The O-ring has been relocated and provided with a groove in the fitting for proper installation. This eliminates the chance of the O-ring being caught in, or damaged by, the mating part. The sealing direction of the O-ring is now set vertically in relation to the contacting surface of the mating part to improve sealing characteristics.

Always consult the service manual for the correct O-ring part numbers and specifications.

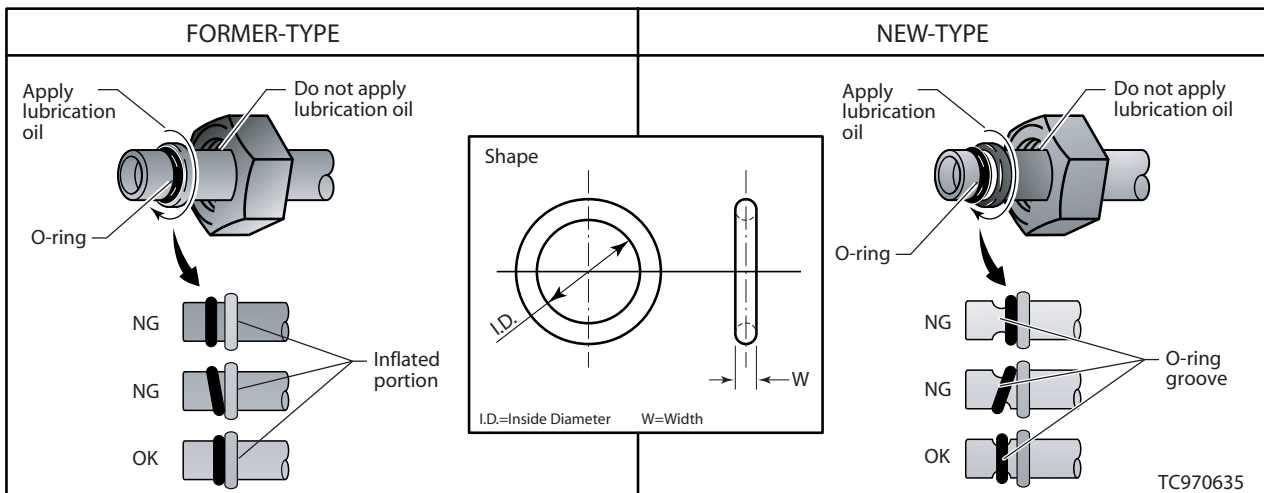



General tips for working with O-rings:

- Always replace used O-rings.
- Be careful not to damage the O-ring or tube.
- When connecting a tube, apply lubricant to circle of O-ring as shown in the illustration. Use the correct lubricant for the system, and avoid applying lubricant to the threaded portion.
- O-rings must be closely attached to the indented portion of the tube.
- Connect the tube until you hear it click, then tighten the nut or bolt by hand until snug. Make sure that the O-ring is installed correctly to the tube.
- Conduct a leak test after connecting a line to make sure the connection seals properly. If a leak is found, recover and evacuate the system, then disconnect the line and replace the O-ring. Tighten the connections of the seal seat to the specified torque.

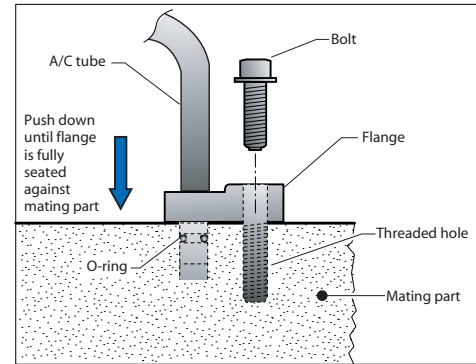

Review Questions

1. The refrigerant cap used on the R134a service port performs which of the following activities when installed: (Check all that apply)
 - Keeps out dust and dirt
 - Provides a tight seal for the charge port
 - Sealing caps should be replaced after each removal
 - Sealing caps prevent leakage from the charge port

2. When repairing or replacing a component in the AC system, the O-rings associated with the component require which of the following processes: (Check one)
 - Replacement any time a line is removed
 - Inspection and reuse if no damage is noticeable
 - Reuse if a leak test shows they made a tight seal prior to disassembly
 - O-rings from the former type lines interchange on vehicles with the new style line

DIAGNOSTIC TECHNIQUES

There is a wide range of methods and tools for helping diagnose climate control problems. Keep in mind that no instrument can tell you what's wrong with a system, it just gives you the information needed to figure out the problem. The performance test is primarily a useful method to recheck the system after you complete any refrigerant repairs, but can also be used to verify problems if an operational check fails to reveal anything.

The most common techniques we present are:

- Examination
- Operational check
- ASIST for researching TSBs, tips, and Least Complex diagnostic trees
- Performance test
- Touch and feel diagnosis
- Manifold gauge set or ACR5 AC Service Center
- Self-diagnosis
- CONSULT-III
- Leak detection dye
- Begin with the quickest, simplest tests. Use the more advanced techniques if you've already tried the simpler ones and need more information.

Least Complex



Most Complex

Plan your diagnostic strategic accordingly



Operational Check

Perform an operational check for verifying a customer complaint, or after repairs for verifying the system operates as it should.

If the vehicle does not have ATC, skip any items which only apply to ATC.

- Blower
- Mode (Discharge Air)
- Ambient Display
- Intake Air
- Defrost
- Econ
- Auto
- Temperature Decrease
- Temperature Increase
- Memory Function

The Operational Check flow chart applies to all ATC systems. Use the appropriate service manual and the owner's manual to check specific operating features. If the vehicle does not have ATC, skip any items which apply only to ATC.

Conditions:

- Engine running at normal operating temperature.



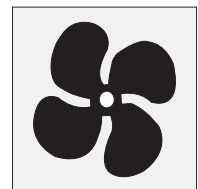

Procedures:

1. Check Blower
 - Operate the blower on all manual speeds. Verify the indicator lights work properly (if so equipped).
 - After checking all blower speeds, leave the blower on high.



2. Check Discharge Air

- Check the operation of the following discharge modes (not all vehicles have all modes):
- Leave the mode control in the foot mode after testing.

Icon	Name	Action
	Face	Verify air comes out of the face vents.
	Bi-Level	Verify air comes out of the face and foot vents.
	Foot	Verify most of the air comes out of the foot vents and a small amount comes out of the defrost vents.
	Foot/Defrost	Verify about 50% of the air comes from the foot vents and about 50% of the air comes from the defrost vents.

3. Check Ambient Display

- Press the ambient button (if present). The ambient air temperature should display for approximately 5 seconds.

4. Check Recirc

- Select the RECIRC position.
- Listen for the intake door to change position (you should hear a change in the blower sound). The RECIRC indicator should light.
- Leave the switch in the RECIRC position.

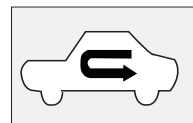

5. Check Defrost

- Press the DEFROST button.
- Verify RECIRC cancels and air exits out the defrost vents.
- Confirm the compressor clutch engages.





6. Check Econ Mode
 - Press the ECON button (if equipped). Defrost should be cancelled. The discharge air outlet depends on ambient temperature, in-vehicle temperature and set temperature.
 - Confirm the compressor clutch is not engaged.
7. Check Auto Mode
 - Select the AUTO position.
 - Confirm the compressor clutch engages.

NOTE: Step 7 does not check that all the automatic functions are working. It only verifies the system goes into the Auto mode.

8. Check Temperature Decrease (for driver and passenger on Dual Zone systems)
 - Select 65° F with the temperature select switch.
 - Check for cold air at the discharge air outlets.
9. Check Temperature Increase (for driver and passenger on Dual Zone systems)
 - Select 85° F with the temperature select switch.
 - Listen for changes in blower speed as set temperature changes.
 - Check for hot air at the discharge outlets.
10. Check the Memory Function
 - Press the OFF button.
 - Switch the ignition OFF.
 - Wait 15 seconds.
 - Switch the ignition ON.
 - Press the AUTO button.

Confirm the set temperature remains at 85° F.

“Touch and Feel” Test

This diagram shows the results from a “touch and feel” diagnosis on a properly operating refrigerant loop. Keep the following points in mind when performing this test.

- Your body is 37° C (98° F). Anything that feels hot is over 37° C (98° F); anything that feels cold is under 37° C (98° F).
- The high side to the condenser should be hot. Use caution and avoid burning yourself when checking high side lines.
- If there is a restriction in the system, the refrigerant line will be cold right after the restriction.
- The “touch and feel” diagnosis is a quick way to see if there is a malfunction in the refrigerant loop. A complete performance test should be performed before starting any repairs.

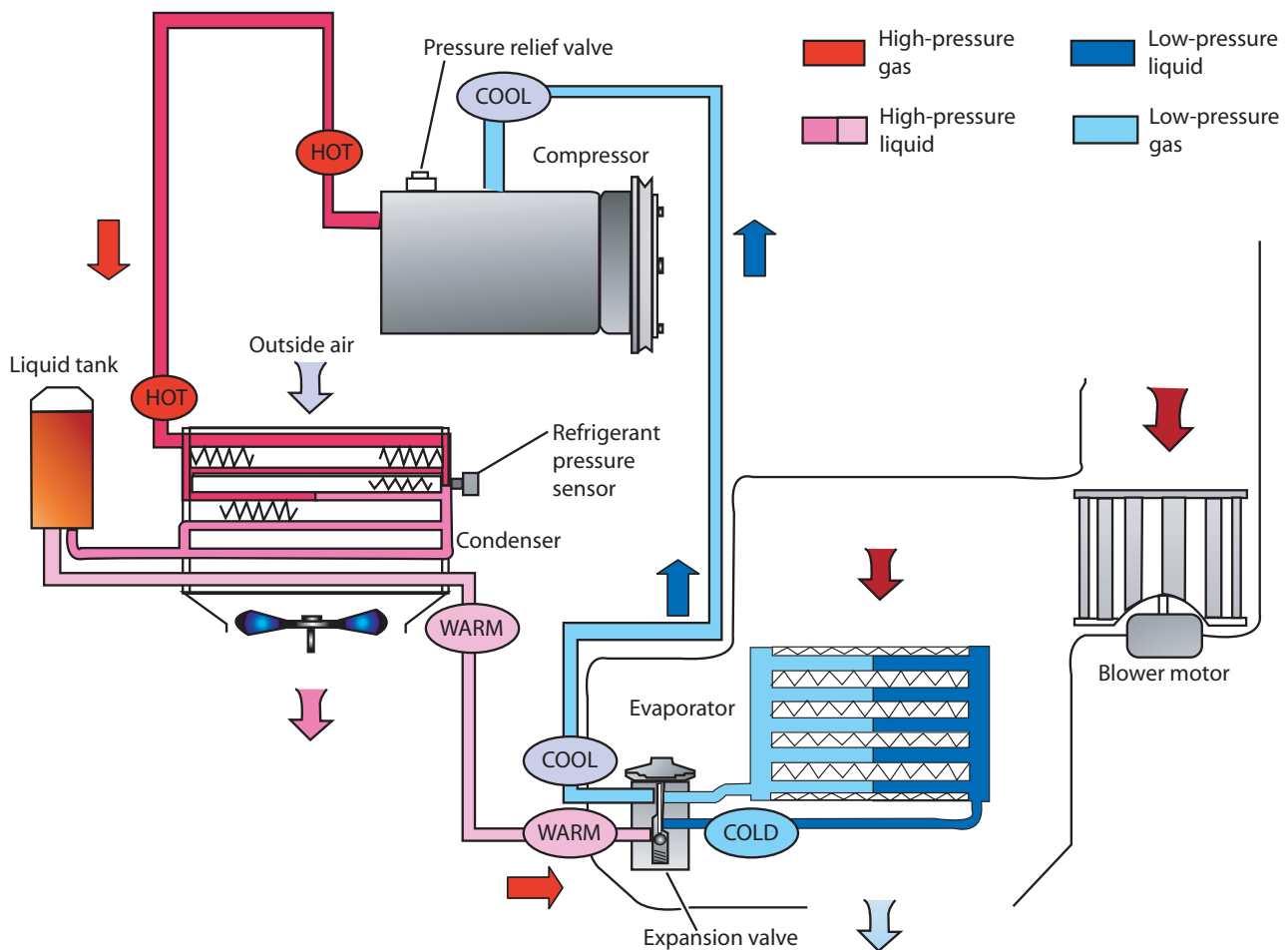

You may have noticed that in the “Refrigerant Loop” section, each section about a component included a “touch and feel” diagnosis of common problems. For example:

- If there is a blockage in the evaporator, the incoming line is cool, the evaporator is not as cold as usual, and the outgoing line is cool as well.



- If the compressor is faulty, the compressor outlet line is only warm to the touch, rather than hot.
- If there is an air flow problem with the condenser, both inlet and outlet are hot, as no heat is transferred out of the refrigerant.
- If the receiver/drier is clogged, the inlet is warm and the outlet is cold.

NOTE: Because the touch and feel method can locate problem areas so quickly, use this technique early in your diagnosis. The Touch and Feel Diagnosis Job Aid is a quick reference for typical results.

Examination

A keen eye can spot certain signs of trouble, so observe the appearance of components while conducting the touch and feel diagnosis.

- Trash and leaves can block air flow through the condenser. The air scoops on sporty models such as the 370Z are notorious for scooping up plastic grocery bags, which stick to the front of the condenser. Since the condenser is hidden by the front bumper, this problem isn't immediately visible.
- Frost may form on a restricted thermal expansion valve.
- Oil leaks on refrigerant lines and components are often a sign of a refrigerant leak. Follow up with a leak detection test.

Review Questions

1. When performing a "Touch and Feel Test", the hottest point in the AC system is at which of the following points: (Check one)
 - Discharge point of the compressor to the condenser
 - Discharge point of the condenser to the receiver dryer
 - At the refrigerant pressure sensor
 - Discharge point of the evaporator to the compressor
2. Which of the following statements accurately describe results of a "Touch and Feel Test"? (Check all that apply)
 - If there is a blockage in the evaporator, the incoming line is cool, the evaporator is not as cold as usual, and the outgoing line is cool as well.
 - If the compressor is faulty, the compressor outlet line is only warm to the touch, rather than hot.
 - If there is an air flow problem with the condenser, both inlet and outlet are hot, as no heat is transferred out of the refrigerant.
 - If the receiver/drier is clogged, the inlet is warm and the outlet is cold.
 - All of the above

Manifold Gauge Set

Part of the air conditioning performance test procedure is reading and interpreting the manifold gauge set. The performance test procedure in the service manual provides information on normal and abnormal gauge readings.

The gauge on the left side is the low side gauge. It reads the pressure on the low side of the system. The low side gauge usually has a scale which reads from 0 to 150 psi and 0 to 30 inches of vacuum.

The gauge on the right side is the high side gauge. It reads the pressure in the high side of the system.

The high side gauge usually has a scale which reads from 0 to 500 psi.

Valves control the refrigerant flow through the gauge set. With the valves closed, refrigerant will not flow through the gauge set. Pressure in the system is read with the gauges in the closed position. When the valves are open, refrigerant flows to the center hose. The valves can be used to control refrigerant charging and discharging.

Keep the following in mind when using a manifold gauge set or recovery/recycling/recharging equipment:

- Always install the gauge set with the engine OFF.
- Make sure the valves are closed when installing the gauge set.
- Never open the high side valve with the engine running.
- Use low loss couplers, quick disconnects and check valves to keep from releasing refrigerant into the atmosphere.
- Separate gauge sets must be used for R-134a and R-12 systems. R-134a systems use quick-disconnect type fittings. R-12 systems use threaded fittings.

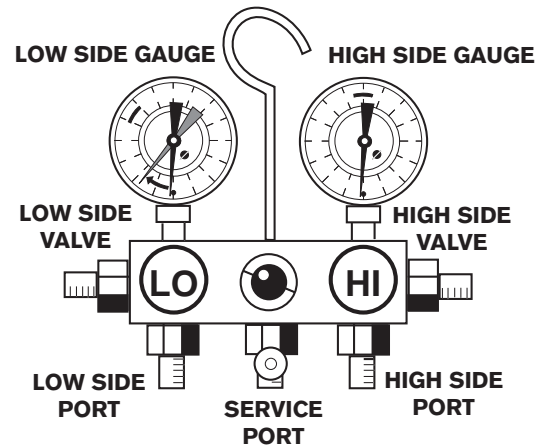

NOTE: Never use a manifold gauge set for discharging refrigerant into the atmosphere. Always use appropriate recovery/recycling equipment when discharging refrigerant.



Performance Test

The operational test verifies that all A/C system controls and modes operate correctly. The performance test checks the system's ability to change the air temperature under different ambient air conditions. If you are not sure what the problem is after completing an operational test, a performance test can give a more accurate picture of how the system is performing.

A performance test is also the most accurate way to recheck your work following repairs.

The performance test measures several factors to verify if the system is operating according to factory specifications.

The test is a series of three temperature/humidity-pressure comparisons:

1. Recirculating-to-Discharge Air Temperature Test
2. Ambient Air Temperature-to-Operating Pressure Test
3. Touch and Feel Diagnosis (see page 51)

Typical Conditions (may vary by vehicle):

- Vehicle location.....Indoors or shaded area w/ventilation
- Doors.....Closed
- Windows.....Open
- Hood.....Open
- Temperature setting.....Max. COLD
- Discharge Air.....Face Vent
- Fan Speed.....4-speed
- A/C Switch.....ON
- Engine Speed.....1,500 rpm or idle, depending on the vehicle
- Operate engine.....10 minutes before taking measurements for performance test

Always refer to the service manual of the vehicle you are working on for the exact performance test conditions.

Discharge Air Temperature Test

This is a comparison of the Relative Humidity, Air Temperature and Discharge Air Temperature of interior air. Test Reading

TEST READING RECIRCULATING-TO-DISCHARGE AIR TEMPERATURE TABLE		
Inside air (Recirculating air) at A/C unit assembly inlet		Discharge air temperature at center ventilator °C (°F)
Relative humidity %	Air temperature °C (°F)	
50 - 60	25 (77)	8.8 - 11.2 (48 - 52)
	30 (86)	12.9 - 15.9 (55 - 61)
	35 (95)	17.0 - 20.4 (63 - 69)
60 - 70	25 (77)	11.2 - 13.8 (52 - 57)
	30 (86)	15.9 - 18.9 (61 - 66)
	35 (95)	20.4 - 24.0 (69 - 75)

Ambient Air Temperature-to-Operating Pressure Test

This is a comparison of the Relative Humidity, Air Temperature and High/Low pressures in the air conditioning system.

Test Reading

Example

AMBIENT AIR TEMPERATURE-TO-OPERATING PRESSURE TABLE			
Ambient air		High-pressure (Discharge side) kPa (bar, kg/cm ² , psi)	Low-pressure (Suction side) kPa (bar, kg/cm ² , psi)
Relative humidity %	Air temperature °C (°F)		
50 - 70	25 (77)	900 - 1,105 (9.00 - 11.05, 9.18 - 11.3, 130.5 - 160.2)	175 - 220 (1.75 - 2.20, 1.8 - 2.2, 25.4 - 31.9)
	30 (86)	1,100 - 1,345 (11.00 - 13.45, 11.2 - 13.7, 159.5 - 195.0)	220 - 270 (2.20 - 2.70, 2.2 - 2.8, 31.9 - 39.2)
	35 (95)	1,310 - 1,605 (13.10 - 16.05, 13.4 - 16.4, 190.0 - 232.7)	270 - 325 (2.70 - 3.25, 2.8 - 3.3, 39.2 - 47.1)
	40 (104)	1,480 - 1,810 (14.80 - 18.10, 15.1 - 18.5, 214.6 - 262.5)	315 - 375 (3.15 - 3.75, 3.2 - 3.8, 45.7 - 54.4)



Leak Detection Equipment and Dye

Leaks in the refrigerant system can be detected with fluorescent dye and a UV light, and then pinpointed with an electronic leak detector.

Current Nissan and Infiniti vehicles already have leak detection dye installed at the factory. These vehicles are identified by a label on the underside of the hood. For earlier vehicles, you will need to inject dye using the tools and materials provided in the kit.

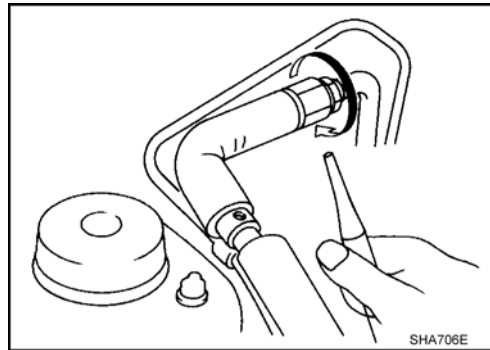

NOTE: Always follow safety precautions such as wearing UV goggles and clean gloves. Immediately clean any UV dye from any painted surfaces as the dye stains the paint.

NOTE: Other substances besides leak detection dye can glow under UV light, producing false positive results. These include the soap-like lubricant used to insert the refrigerant lines through the rubber grommets in the fire wall. If the glowing material wipes off easily, it is not leak detection dye. You can also refer to the service manual and TSB's to check whether or not the vehicle has leak detection dye already installed.

Leak Detection Dye Safety

Using leak detection dye is a convenient technique for finding leaks quickly. However, certain safety precautions are in order when using it.

- Read the manufacturer's operating instructions and precautions provided with the kit prior to starting work.
- Protect your eyes from the UV light. Always wear UV goggles when operating the UV light, and never stare directly into the beam of light.
- Do not spill the dye on painted surfaces, carpet, interior surfaces, skin, hair, or clothes. Change gloves if they become contaminated to avoid transferring the dye to other objects.
- Fluorescent dye is permanent on contact with porous or painted surfaces, and can make stains that are visible under certain types of outdoor lighting.



- NEVER add leak detection dye to the Altima Hybrid, M Hybrid or LEAF Electric vehicles. PAG oil is incompatible with the electric compressor. Use ONLY ND-11 refrigerant oil in these systems.
- Do not add more than one bottle of leak detection dye to an air conditioning system. Also, some vehicles may already have leak detection dye. Check with a UV light before adding additional dye. All current Nissan and Infiniti vehicles have had leak detection dye installed at the factory. Leak detection dye is fluorescent for three years or unless the compressor is replaced and the system is flushed.
- There are different leak detection dyes for R-134a and R-12 systems. Use only the correct type of leak detection dye for your system, or air conditioning system damage may occur.

Please note that the cleaner included in the kit only works on bare metal-not skin, hair, carpet, or auto paint. The purpose of the cleaner is to clean dye traces from metal components, such as refrigerant lines and condenser fins, to avoid false readings at the next air conditioning service.

CAUTION: Refrigerant leak detection dye stains most materials, including skin and painted surfaces, permanently and immediately! Always wear protective gloves while working with the dye. Be certain your hands or latex gloves are not contaminated with dye before touching painted surfaces (such as the vehicle's doors or hood) or interior surfaces (such as ATC controls).

NOTE: Other substances besides leak detection dye can glow under UV light, producing false positive results. These include the soap-like lubricant used to insert the refrigerant lines through the rubber grommets in the fire wall. If the glowing material wipes off easily, it is not leak detection dye. You can also refer to the service manual and TSB's to check whether or not the vehicle has leak detection dye already installed.



Self Diagnosis

You can access diagnostic trouble codes (DTC's) in the climate control system for assistance troubleshooting existing malfunctions. Depending on the vehicle, self-diagnosis checks the following items:

- Control panel display
- System sensors
- Mode and intake door position
- Actuators
- Temperature sensor accuracy

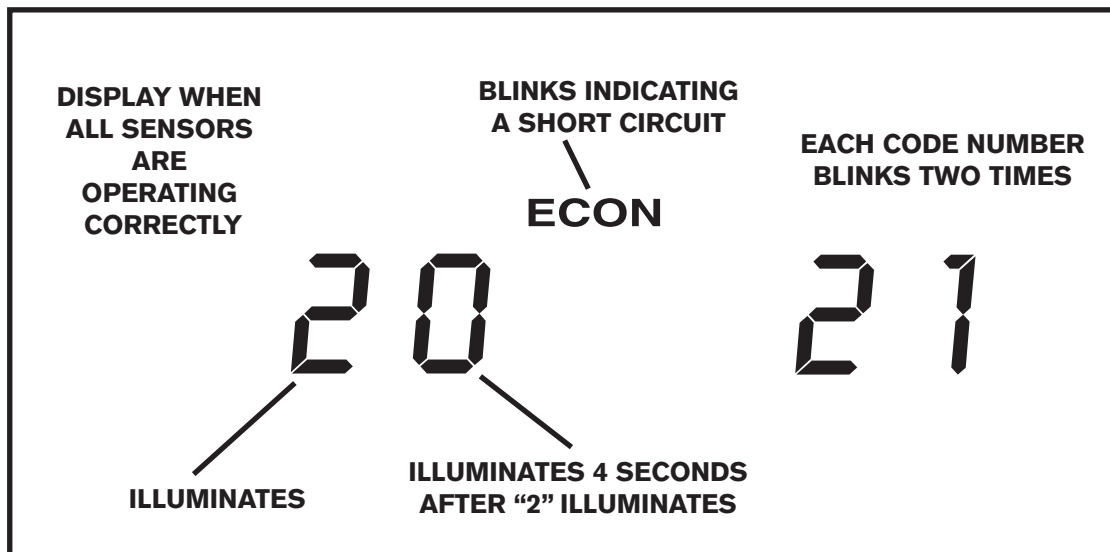

Refer to the service manual for the specific vehicle you're servicing.

CONSULT-III for Electrical Diagnosis

On some models, you can use CONSULT-III for diagnosing the climate control system. Even if CONSULT-III doesn't show all the sensor readings, sometimes you can use it as a useful short-cut to rule out some of the possible causes.

All Nissan and Infiniti vehicles are CONSULT-III compatible. This allows technicians to view signals which indicate:

- AC compressor request signals
- AC relay operation
- Fan operation
- AC pressure sensor
- AC ON signal operation
- AC sensor values

Information is located in both BCM and engine for AC operation.

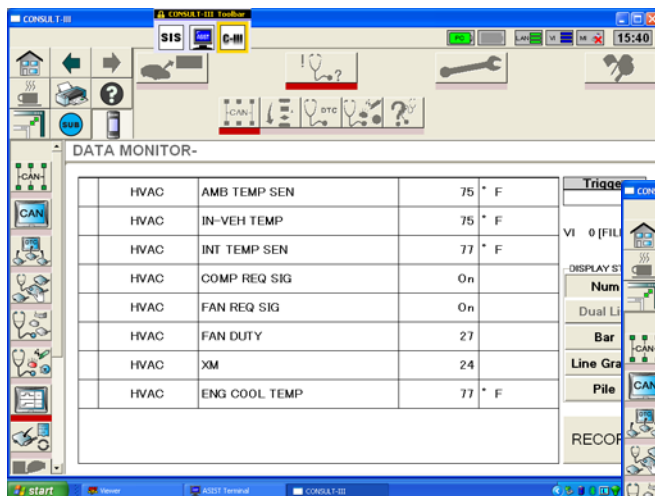

DATA MONITOR-

HVAC	AMB TEMP SEN	75	° F
HVAC	IN-VEH TEMP	75	° F
HVAC	INT TEMP SEN	77	° F
HVAC	COMP REQ SIG	0n	
HVAC	FAN REQ SIG	0n	
HVAC	FAN DUTY	27	
HVAC	XM	24	
HVAC	ENG COOL TEMP	77	° F

HVAC Data Monitor

Engine Data Monitor



DATA MONITOR-

ECM	COOLAN TEMP/S	77	° F
ECM	AIR COND SIG	0n	
ECM	LOAD SIGNAL	0n	
ECM	HEATER FAN SW	0n	
ECM	AIR COND RLY	0n	
ECM	COOLING FAN	Low	
ECM	AC PRESS SEN	1.490	V

These screens indicate the ECM is sending a ground signal to the A/C relay. The relay could be inoperative.

For example, using CONSULT-III, determine whether or not the ECM provides a signal to the A/C relay in the IPDM E/R. Read the schematic in the ESM and view the CONSULT-III screen showing which components are relevant to the problem.



Refrigerant Recovery & Recycling

Increased concerns regarding the environment as well as Federal regulations have prompted the development of equipment that prevents releasing refrigerant into the atmosphere when servicing vehicle air conditioning systems. This equipment, the ACR5 AC Service Center evacuates, filters, recycles the refrigerant, and recharges the system before and after system repairs.

Before opening the system, use the ACR5 AC Service Center to recover/remove the refrigerant. As the refrigerant is recovered it is recycled to remove any moisture or contaminants. Refrigerant oil is separated from the refrigerant, and the refrigerant is filtered, dried and stored in a container for reuse.

After repairing the air conditioning system, an evacuation pump on the recovery/recycling station removes moisture and contaminants from the system. The station then recharges the air conditioning system with clean, dry refrigerant.

The recovery/recycling station also contains high and low pressure gauges for monitoring air conditioning system operation. The gauges are also used to troubleshoot and diagnose system malfunctions.

NOTE: Separate stations are required for R-134a and R-12 systems. You cannot use an R-12 recovery/recycling station on an R-134a system. To prevent refrigerant and equipment contamination, A/C systems using R-134a refrigerant use different couplers than R-12 systems. The ACR5 AC Service Center samples the refrigerant prior to recovery.

For R-12 equipped vehicles, the ACR-3 machine can be used for recovery, recycling and recharging refrigerant.

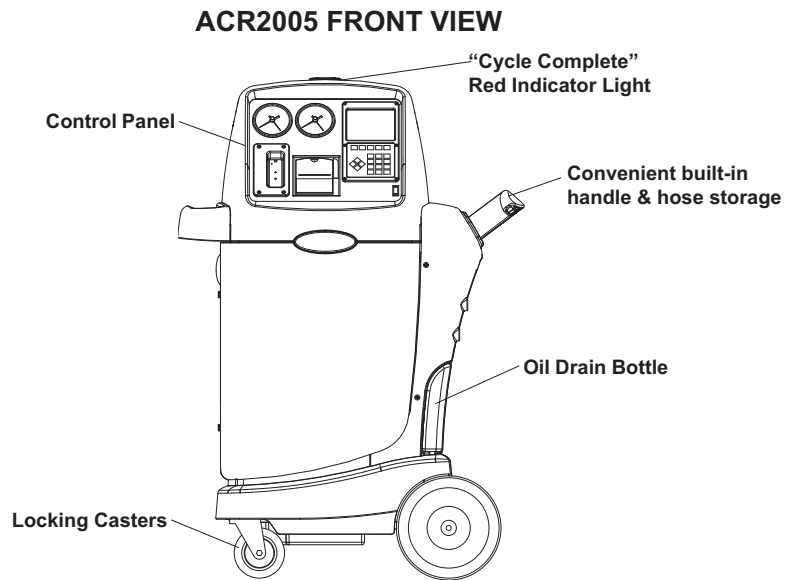

CLIMATE CONTROLLED SEATS

Certain Nissan and Infiniti models utilize climate controlled front and rear seats which provide cooling, dehumidification, and heating to seat occupants. This is accomplished through a unique active temperature management system.

The Climate-Controlled seat system receives input from the driver or front passenger and from temperature sensors located in each seat, warming or cooling ambient cabin air accordingly and then circulating air through seat surfaces using a fan mounted under the seat and in the seat back. Each seat has individual input controls allowing the seat occupant to set the system to the desired level of heating or cooling for year round personal comfort. The Climate-Controlled seats are not connected to the HVAC system.

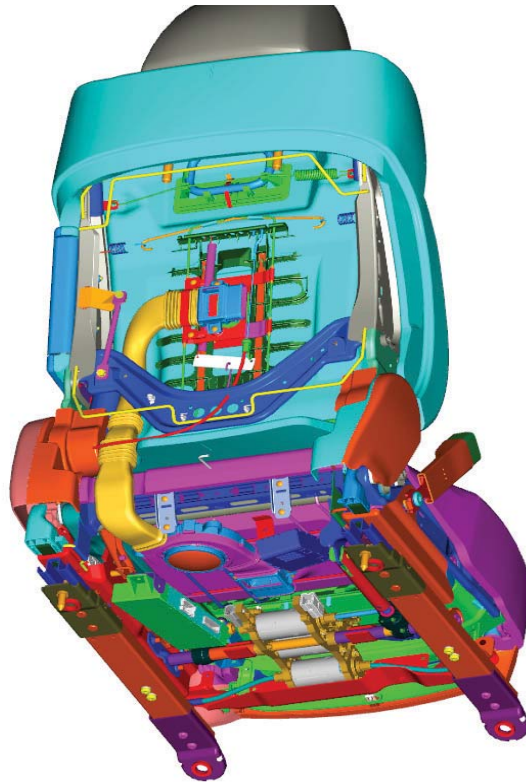

Operation

The heart of the system is a highly efficient, solid-state Thermoelectric Device (TED), which rapidly converts electric current to thermal effect, using no environmentally sensitive CFCs or other coolants. The Thermoelectric Module consists of hundreds of semi-conductor pellets, sandwiched between flexible substrate materials. Because of the configuration of these pellets, when electricity is applied, one side of the module absorbs heat, thus becoming cold, while the other side rejects heat turning hot. When the direction of the electricity is reversed the opposite sides become hot or cold.

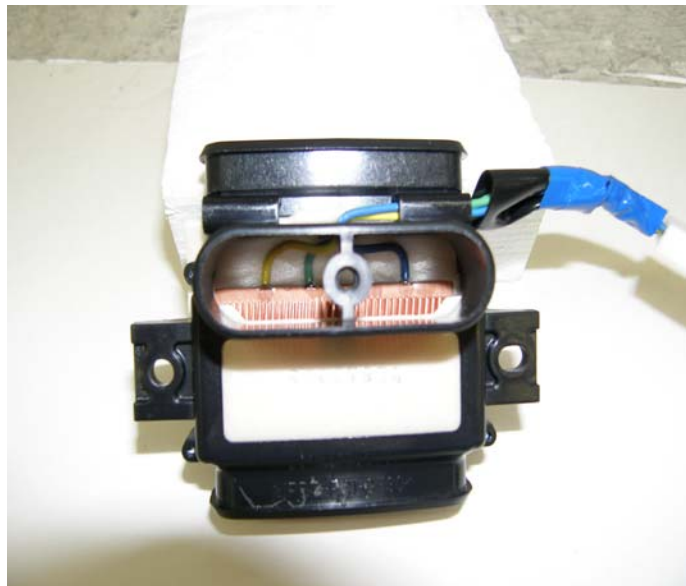

Air is circulated over the TED and through the seat using a brushless direct current (DC) fan. CCS use an electronic control module to manage the thermal outputs of the system and control algorithms designed to provide the seat occupant with maximum comfort. Thermoelectric cooling technology to heat and cool the front seats is termed the "Peltier Effect."

Peltier Effect = A phenomenon discovered by French physicist Jean Peltier in the 19th century.



NOTE: The Thermoelectric Device (TED) uses a Peltier circuit of p-type and n-type semiconductors connected in series using copper electrical conductors. The semiconductors are sandwiched between two insulating ceramic plates. When current is applied to the TED, one side releases energy as heat, while the opposite side absorbs energy and gets cold. By reversing the current flow, the hot and cold sides reverse.

The CCS system provides thermal comfort in 2-3 minutes in most normal driving conditions. Seat occupants can adjust the seat surface temperature at any time by repositioning the controls.

Malfunctions

Anytime a customer has a concern of poor seat heating or cooling inspect the TED unit and/or cooling fan.

Diagnosis

Inspect seat heating and cooling with controls set to maximum cold and maximum hot. Refer to the ESM for the applied vehicle and diagnostic procedure.

Review Questions

1. TED is an acronym for which of the following: (Circle one)
 - Thermonuclear Device
 - Thermoelectric Device
 - Thermistor Electric Device
 - Transistor Element Device
2. When applying current to the TED device, the following takes place: (Check one)
 - One side gets hot, the other side remains the same temperature
 - Both sides get hot or cold depending upon switch position
 - One side gets hot, the other side gets cold
 - One side gets hot, the other side gets cold, the air flow changes depending upon air flow through the device



FOUR-STEP REPAIR STRATEGY

You are familiar with the Four-Step Repair Strategy from your previous training courses. It will be no surprise that the same approach works for climate control. The four steps are:

Step 1 - VERIFY the customer's complaint

Step 2 - ISOLATE the problem

Step 3 - REPAIR the source of the problem

Step 4 - RECHECK the repair

Following this technique can eliminate unnecessary checks that could result in much wasted time (yours and the customer's) and possibly lead to incorrect diagnosis and repair.

Step 1 - Verify the Customer's Complaint

Verifying the customer's complaint should always be the first step towards quick and accurate diagnosis. The purpose of verification is to compare the actual vehicle condition to the description found on the repair order.

Normal operating conditions are often misinterpreted by customers as malfunctions. Sometimes, a problem that the customer is not aware of is repaired without his actual complaint being addressed. Remember that thorough verification confirms the validity of the complaint, and ensures that the problem you're repairing is the one the customer has in mind.

Elements of verification include the What and When of a symptom, as well as the opportunity for you to determine what is functioning properly. When verifying a complaint, always keep the following in mind:

- Get as much information as possible from the repair order. You may need to ask the service advisor to call the customer and clarify symptom details or gather further information.
- Make sure you know how the component is supposed to work before deciding if it works properly. The service and owner's manuals can help you determine proper operation of components. Also, inspecting a known good vehicle can save valuable time.
- Do not attempt to repair a problem you cannot verify.
- Whenever possible, perform a complete performance test and confirm the customer's concern.

Verification procedures for air conditioning problems include:

- An operational check of the system.
- A performance test of the system.

Step 2 - Isolate the Problem

After you've identified the system malfunction, your next step is determining what is causing the malfunction by isolating the problem. A good isolation process filters through the many possible causes of a problem, and allows you to logically identify the true cause.

Isolation is easier if you divide the whole system into its related parts, as in these examples:

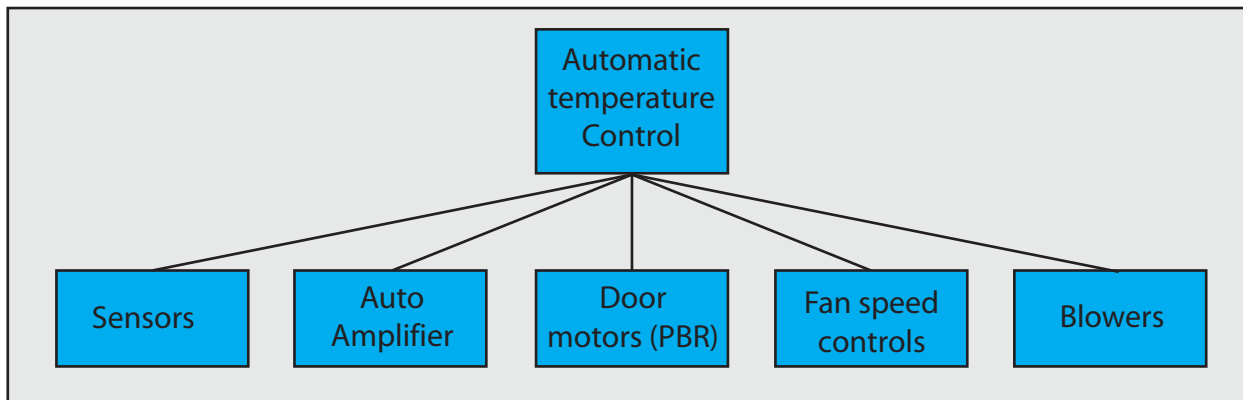
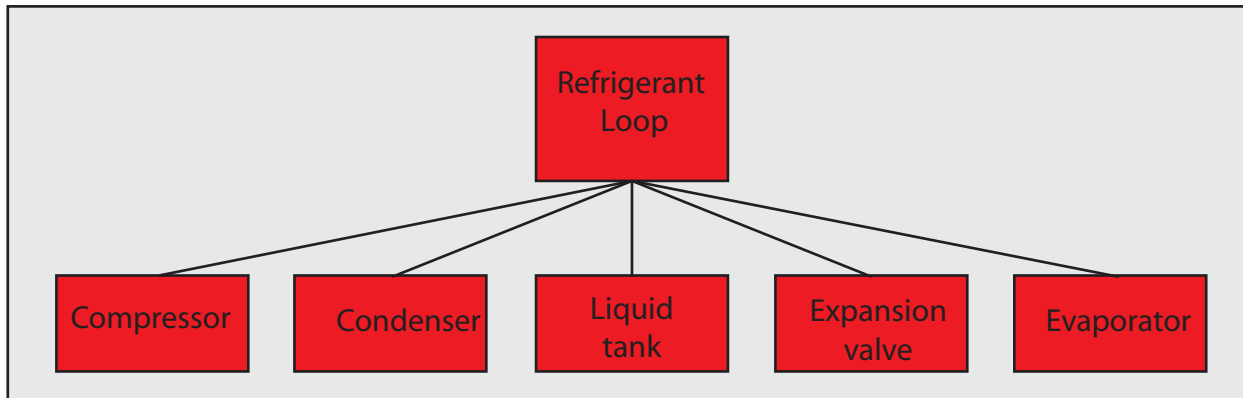

NOTE: The isolation process begins with a large system and keeps dividing it into smaller systems until the malfunction is found.

The quickest, easiest checks should always be done first, because they speed up troubleshooting in these two ways:

Problems will be found with less time and effort if they originate in the easy-to-check system component.

Eliminating the easy-to-check system or component first allows you to isolate the cause with less time and effort.

Isolating a problem requires many or all of the following:

- Verification of customer complaint
- Touch and feel diagnosis



- Performance test
- Service manual trouble diagnosis procedures to isolate control system concerns

Use self-diagnosis or CONSULT to get as much system information as possible. Self-diagnosis won't always point you directly to the problem, but it is a good way of getting a lot of information in a short period of time.

Concentrate on one section of the ATC system at a time. For example, if you discover an air mix door problem and a fan problem, isolate each problem individually. One repair will often fix both problems.

Step 3 - Repair The Source of the Problem

The repairs you perform on the climate control system, the air conditioning components, the heating components, and the ATC controls vary greatly - from replacing a fuse, to adjusting an air mix door, or replacing a compressor. Since the relationship of climate control components can be complex, it is always best to use the appropriate service manual or ASIST when performing the repairs. In addition, always check for relevant Technical Service Bulletins (TSBs). All of these resources help make the diagnosis and repair accurate and completed in a timely manner.

NOTE: Always use the service manual while making repairs. The ESM provides the most up-to-date information on current repair procedures.

While repairing malfunctions in the refrigerant loop keep the following points in mind:

- Always use proper refrigerant recovery and recycling equipment when discharging refrigerant. Never discharge refrigerant into the atmosphere.
- To prevent moisture or contaminants from entering the system keep new components sealed until installation. In addition, seal any openings in the system while making repairs.
- Always replace the O-rings and lubricate them with refrigerant oil before installation.
- Use a torque wrench and backup wrench when loosening and tightening hose and tubing fittings.
- After repairs, evacuate the system for at least 20 minutes to make sure the system is free of moisture.
- After 20 minutes, check for system leaks by shutting both valves of the recovery/recycling equipment, turning off the vacuum pump and letting the system sit for 5 to 10 minutes. If the vacuum reading increases towards positive pressure, repair the leak before you proceed.
- Before recharging, adjust the oil level in the system. Refer to the service manual for the correct procedure.
- Always charge refrigerant using an electronic scale, charging cylinder or charging station to insure proper refrigerant amount.
- Test refrigerant loop integrity with the A/C leak detector.



- Most ATC repairs are electrical in nature. In addition, there are also mechanical repairs and adjustments to parts in the system:
 - Door control rod adjustments
 - “Trimmer” adjustments
 - FRE/REC adjustments
 - Potentiometer adjustments

Step 4 - Recheck the Repair

The best way to ensure customer satisfaction is to always recheck or verify your work after completing a repair. A recheck confirms that the original problem has been repaired and that no additional problems have been caused during the repair or masked by the previous problem.

The best way to recheck a climate control repair is with a complete Operational Check and Performance Test. Always recheck your work under the same conditions used to verify the original complaint.

The 4-Step Repair Technique is a logical and effective system for troubleshooting control system complaints. Many technicians use this procedure so frequently that it becomes second nature to them. Guesswork is a poor substitute for a systematic approach to troubleshooting.

Example

A customer complains the air conditioner doesn't cool.

The air conditioning system contains many subsystems. They include:

- The refrigerant loop
- The electrical control systems for the:
 - Compressor
 - Condenser Fan
 - Blower Motor
 - Air Mix Door
 - Mode Door
 - Intake Door
- The mechanical parts of the air flow system

Verification

An operational check shows that the compressor clutch, blower motor, intake door and mode door are working properly. Next, a performance test shows that the air is not as cold as it should be, given the temperature and humidity.



Diagnosis

Touch and feel diagnosis and manifold gauge readings demonstrate that the refrigerant loop is working correctly even though the discharge air is too warm. In this scenario the refrigerant loop seems capable of cooling properly but the discharge air is still too warm. In this case, concentrate on the air flow system during further isolation. Let's look at two items that affect air temperature, the blower in the cooling module and the air mix door.

Inspection/Isolation/Repair

The operational check shows the blower in the cooling module operates correctly. However, further inspection of the air mix door system shows the mechanical linkage disconnected and the air mix door stuck in the heating position. Before repairing the linkage, determine the cause of the problem so you can get to the root of the symptom. In this case, the problem turned out to be the clip holding the air mix door linkage in place had broken.

Conclusion

Through this example you can see that by conducting a thorough visual inspection and a few tests, you can eliminate some of the sub-systems and simplify the isolation procedure.