

# VOCSN

## Clinical Quick Start Guide



VOCSN offers mechanical **V**entilation, **O**xygen, **C**ough, **S**uction, and **N**ebulizer therapies in one compact, portable, lightweight device.

This **Quick Start Guide** is intended to provide a high-level overview of VOCSN use, and does not contain all the information required to operate VOCSN safely. For detailed instructions for use, see the [Clinical and Technical Manual](#), available online at [VentecLife.com/VOCSNmanual](http://VentecLife.com/VOCSNmanual).



VENTILATION

## Critical Care Ventilator

VOCSN is one of the few portable ventilators to achieve the rigorous critical care standard<sup>1</sup> for safety and accuracy. The ventilator provides invasive, noninvasive, and mouthpiece ventilation and delivers a comprehensive set of modes and settings to meet patient needs.

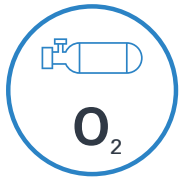

OXYGEN

## 6 L/min Equivalent Internal Oxygen Concentrator

The VOCSN internal oxygen concentrator and Oxygen Direct™ system deliver the equivalent of 6 L/min of oxygen or up to 40% FiO<sub>2</sub>. External high pressure and low pressure oxygen sources can be connected when needed.

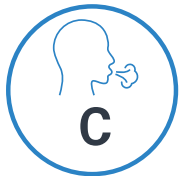

COUGH

## Touch Button Cough

Touch Button Cough™ therapy is activated in seconds rather than minutes, without changing the circuit. Breath Sync monitors patient breathing and triggers a cough at a natural point in the breathing cycle.



SUCTION

## Hospital Grade Suction

Hospital grade suction system provides consistent high flows throughout the entire suction experience. VOCSN Suction therapy is up to three times quieter than traditional portable suction machines.

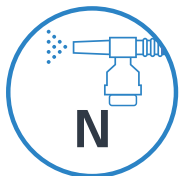

NEBULIZER

## High Performance Nebulizer

VOCSN automatically compensates for the airflow from the nebulizer drive to ensure accurate ventilation and comfortable breathing. VOCSN records each medication use and turns off the nebulizer when the therapy is complete.

Copyright: © 2020, Ventec Life Systems  
22002 26th Ave SE  
Bothell, WA 98021

Part Number: LBL-00054-000, Rev H

CAUTION: Federal law restricts this device to sale by or on the order of a physician.

<sup>1</sup> ISO 80601-2-12

<b>VOCSN Configurations and Hardware</b>	<b>4</b>
<b>Software Overview</b>	<b>5</b>
Locking and Unlocking the Touchscreen	5
Night Mode and Day Mode	6
Clinician Access	6
Permissions	7
Enable Prescribed Therapies	7
Exit Buttons	7
Multi-View	7
<b>VOCSN Placement</b>	<b>8</b>
<b>Powering VOCSN</b>	<b>8</b>
The Power Supply	8
Batteries	9
<b>Connecting Patient Circuits</b>	<b>10</b>
Connecting and Removing a Bacterial Filter	10
Mouthpiece Patient Circuits	10
Active, Passive, and Valveless Ventec One-Circuits	11
Connecting a Ventec One-Circuit O2 Tube	12
Connecting an Active Ventec One-Circuit Multilumen Tube	12
<b>The Pre-Use Test</b>	<b>12</b>
<b>Changing Ventilation, Oxygen, and Cough Controls</b>	<b>13</b>
<b>Alarms</b>	<b>14</b>
Setting Ventilation and Oxygen Alarms	14
Alarm Priorities	15
Alarm and Event Logs	15
Silencing Alarms	15
Connecting a Nurse Call System or Remote Alarm	15
<b>Ventilation Therapy</b>	<b>16</b>
<b>Oxygen Therapy</b>	<b>16</b>
Connecting External Oxygen	16
<b>Cough Therapy</b>	<b>17</b>
<b>Suction Therapy</b>	<b>17</b>
Connecting a Suction Canister	18
The Ventec Travel Suction Canister	18
The External Suction Canister Adapter (Sold Separately)	18
<b>Nebulizer Therapy</b>	<b>19</b>
External Nebulizer Compensation	19
Internal Nebulizer Therapy	19
<b>VOCSN Therapy Interactions</b>	<b>20</b>
Maintaining Oxygenation During Nebulizer or Suction	20
<b>Comparable Ventilation Modes</b>	<b>21</b>
Non-Invasive Ventilation Modes	21
Volume Ventilation Modes	22
Pressure Ventilation Modes (Including Volume-Targeted)	22
<b>VOCSN Controls Setup</b>	<b>23</b>

# VOCSN Configurations and Hardware

VOCSN may include all five therapies and all the features described in this guide, or just the set of therapies and features purchased or prescribed by the treating physician. Depending on its configuration, VOCSN will be able to provide **V**entilation, **+O**xygen Concentration, **+C**ough, **+S**uction, and/or **+N**ebulizer therapy. It may also be able to provide oxygen from an external high-pressure source and FiO2 monitoring (**+Pro** configurations) or low-pressure oxygen (all configurations). The configuration name is based on the therapies VOCSN can provide. For example, the **V+C** configuration provides **V**entilation**+C**ough therapies. The configuration name is printed on the back of the device.

Configuration (Located on Device Rear Label)	Ventilation (V)	O2 Concentration (+O)	Cough (+C)	Suction (+S)	Nebulizer (+N)	High-Pressure External Oxygen and FiO2 Monitor (+Pro)	Low-Pressure External Oxygen
<b>V+O+C+S+N+Pro</b>	Yes	Yes	Yes	Yes	Yes	Yes	Yes
<b>V+O+C+S+N</b>	Yes	Yes	Yes	Yes	Yes	No	Yes
<b>V+C+Pro</b>	Yes	No	Yes	No	No	Yes	Yes
<b>V+C</b>	Yes	No	Yes	No	No	No	Yes

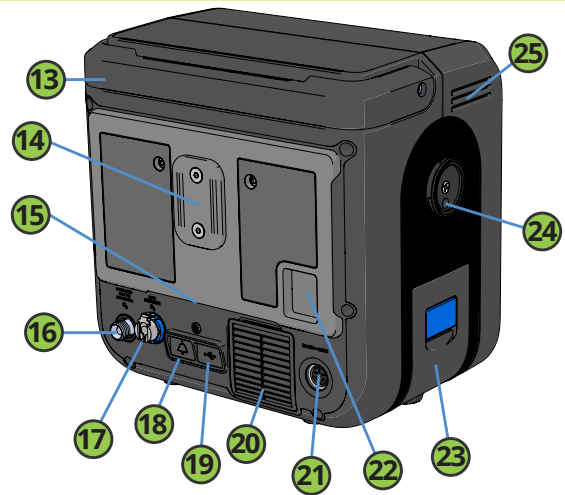
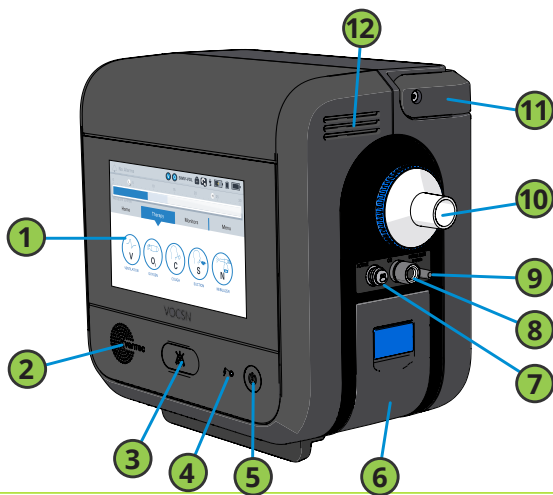

1	Touchscreen	13	Handle
2	Speaker	14	T-Slot mount
3	Alarm Silence button	15	Cooling air outlet and Cough therapy exhaust
4	External Power / Charge Status indicator light	16	High-pressure O2 input port (+Pro configurations only)
5	Power button and indicator light	17	Low-pressure O2 input port
6	Removable, rechargeable battery	18	Remote alarm or Nurse Call Cable port
7	Active exhalation valve connection port	19	USB port for use by trained personnel only. See the Clinical and Technical Manual for details.
8	Ventec One-Circuit O2 tube connection port (+O configurations only)	20	Cooling air intake and filter
9	Nebulizer drive port (+N configurations only)	21	Power connection port
10	External bacterial filter and Ventec One-Circuit connection port	22	Patient air inlet and filter
11	Handle	23	Removable, rechargeable battery
12	Cooling air outlet	24	Suction interface
		25	Cooling air outlet

## Software Overview

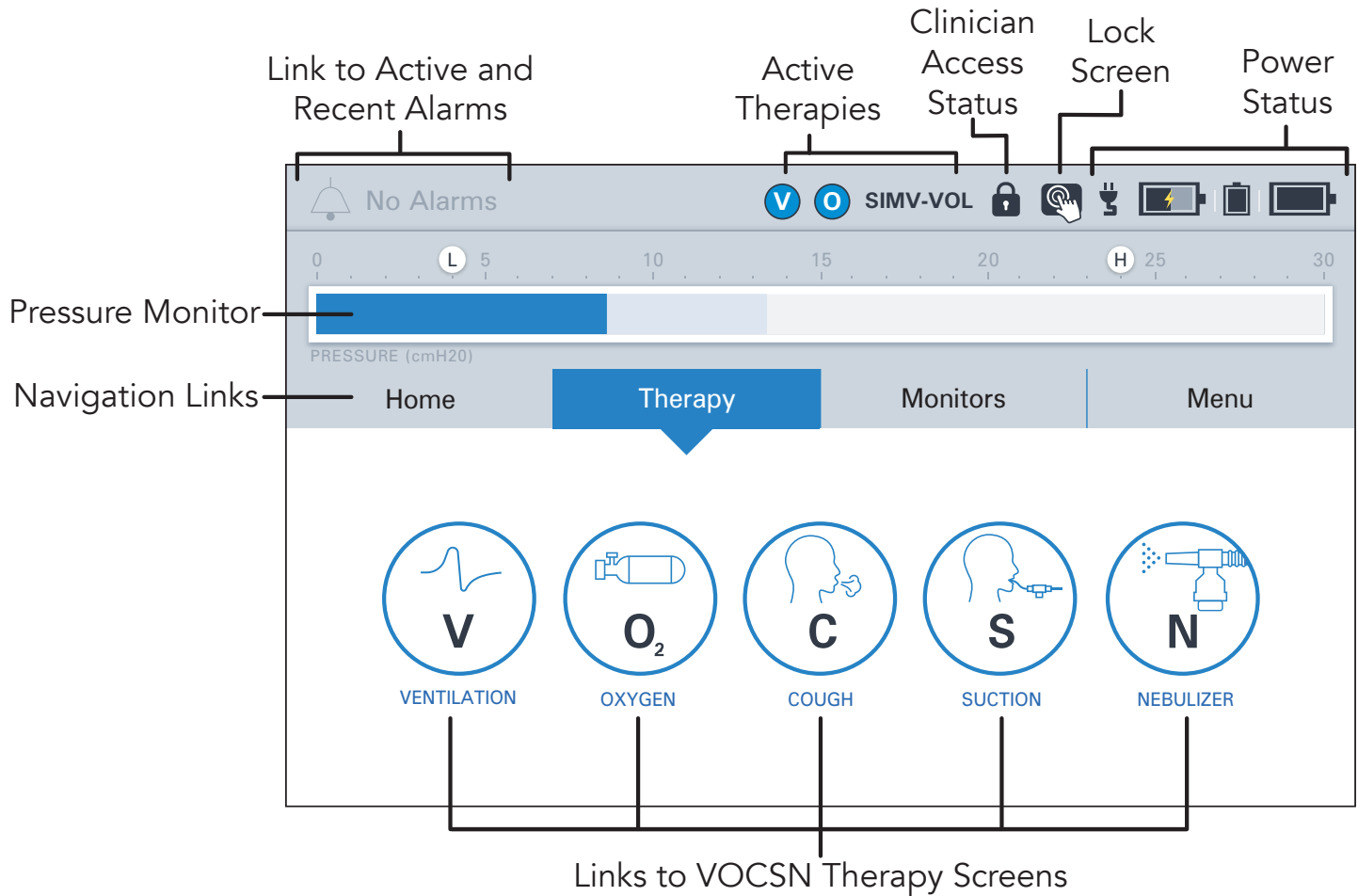

## Locking and Unlocking the Touchscreen

To lock and unlock the VOCSN touchscreen, **use the status bar** to press and hold the lock screen button for three seconds. A pop-up message will appear to confirm your action.



### Night Mode and Day Mode

Use the [Home](#) screen to change between Night Mode and Day Mode.

- 1 Press [NIGHT MODE](#) to dim the LCD display.
- 2 Press [DAY MODE](#) for full screen brightness.



DAY MODE



NIGHT MODE

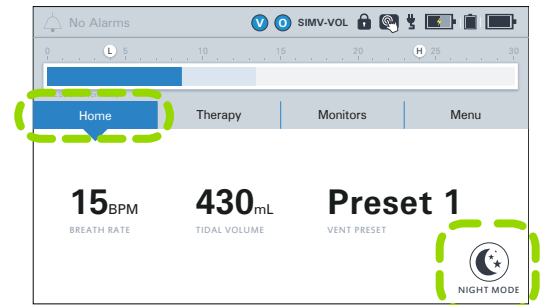

### Clinician Access

To lock or unlock VOCSN:

- 1 Press [CLINICIAN ACCESS](#) in the [Menu](#) tab.
- 2 Locate the device serial number printed on the VOCSN back label. It is also visible from the Service section of the [MY VOCSN](#) screen.
- 3 Enter the four-digit Clinician Access passcode (the last four digits of the device serial number), and then press [ACCEPT](#).

If the [UNLOCK REQUIRED?](#) control is set to [No](#), all VOCSN controls will be configurable by any VOCSN user. When set to [Yes](#), controls set to [Clinician Only](#) in the [PERMISSIONS](#) screen will be locked.

To enable or disable the Clinician Access feature:

- 1 Press [DEVICE SETTINGS](#) in the [Menu](#) tab.
- 2 Press edit, and then change the [UNLOCK REQUIRED?](#) control to [Yes](#) or [No](#).

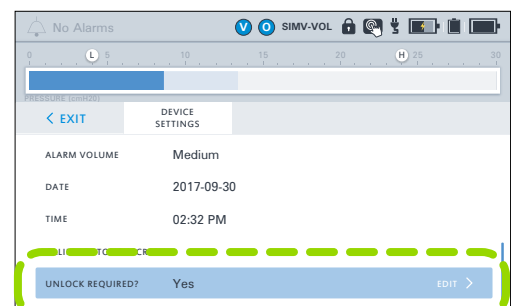
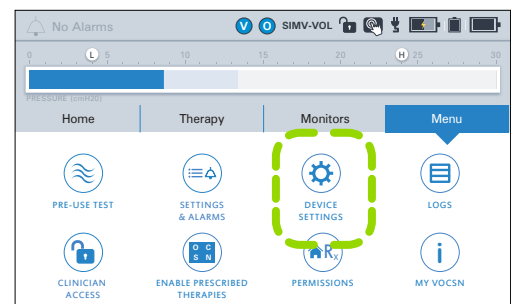
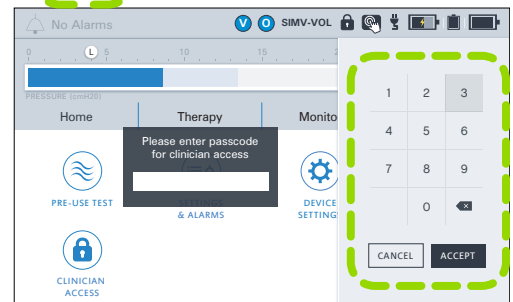
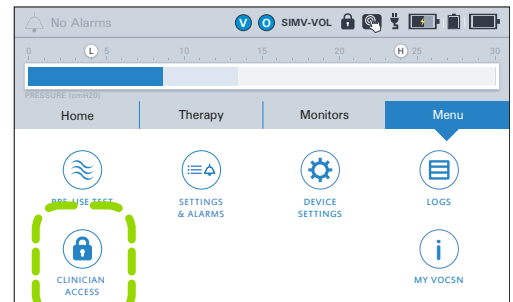

### Permissions

Using the Permissions feature, VOCSN can be locked so that a Clinician Access passcode is required to change controls. To configure which controls are locked, press **PERMISSIONS** in the **Menu** tab. Then, use the toggles to set each control.

- **User and Clinician** - Unlocked. Accessible at all times.
- **Clinician Only** - Locked. Control changes require the Clinician Access passcode.

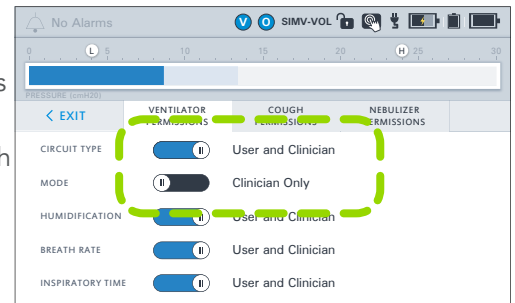

### Enable Prescribed Therapies

Press the **ENABLE PRESCRIBED THERAPIES** button to enable or disable VOCSN therapies such as the internal O2 Concentrator, Cough, Suction, Nebulizer, and/or the FiO2 Monitor.

This feature allows clinicians to enable a suite of therapies appropriate for the patient condition, and disable others.



The Enable Prescribed Therapies button is only visible when VOCSN is in Clinician Access mode.

### Exit Buttons

VOCSN software has two types of **EXIT** buttons to navigate to the previous screen:

- Inside therapy screens, the **EXIT** button appears as a back arrow on the left-hand side of the screen.
- Inside configuration screens, the **EXIT** button will appear as a tab in the upper left-hand corner.

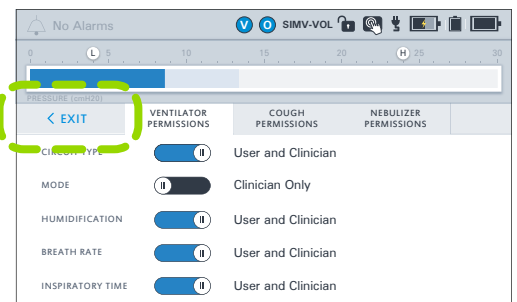
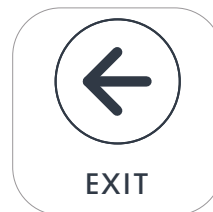

### Multi-View

VOCSN Multi-View is the first comprehensive reporting solution for ventilator-dependent patients. To obtain data from VOCSN and generate a report:

- 1 Install a USB drive into the USB port in the back of VOCSN.

Note: USB drives used with VOCSN must be USB 2.0, and formatted to FAT32. Do not plug anything else into the VOCSN USB port.

- 2 Navigate to the Event Log by pressing **Menu** and then the **LOGS** button. Press the **Events** tab. Then, press the **EXPORT** button to begin exporting Multi-View data to the connected USB drive.
- 3 When the export is complete, press **OK** and remove the USB drive.
- 4 Insert the USB drive into a computer, and open the "VOCSN" folder on the drive. Ensure you're connected to the internet and double-click the "Click to open Multi-View.html" link to open the Multi-View portal.
- 5 Follow the instructions on the Multi-View portal to upload data in the "Multi-View Exports" folder and generate reports. For detailed instructions, see the Clinical and Technical Manual at [VentecLife.com/VOCSNmanual](http://VentecLife.com/VOCSNmanual).



### VOCSN Placement

When selecting a place to operate VOCSN, keep the following in mind:

- Do not block VOCSN air inlets and vents.
- Do not operate VOCSN on its back or on compliant bedding, which may obstruct the airflow around it.
- Do not cover VOCSN with towels or other materials.
- VOCSN should be placed in a well-ventilated area, free of airborne pollutants, contaminants, and fumes.
- Always have a backup means of ventilation available, as well as a backup means of any other therapy critical to patient care.
- Do not operate VOCSN near smoke, open flame, or heat sources while Oxygen therapy is in use. This could cause fire or explosion and serious harm to the patient.
- Over time, direct sunlight may compromise the integrity of VOCSN plastic housing or the Ventec One-Circuit. Place VOCSN in a location that is not exposed to extended periods of direct sunlight.
- Ensure the environment is within the recommended operating range of temperature, altitude, and relative humidity for VOCSN. (5 to 40 °C, 700 to 1060 hPA, 15% to 90% RH)

### Powering VOCSN

Use the Power button on the front right side of VOCSN to turn it on and off. Listen for two audio tones every time you power on VOCSN. This verifies the VOCSN backup alarm, which is used in case of an Inop alarm condition or issue with the VOCSN speaker.



### The Power Supply

Whenever possible, connect VOCSN to an external source of continuous power. Verify the external power indicator appears on the touchscreen when VOCSN is plugged in.

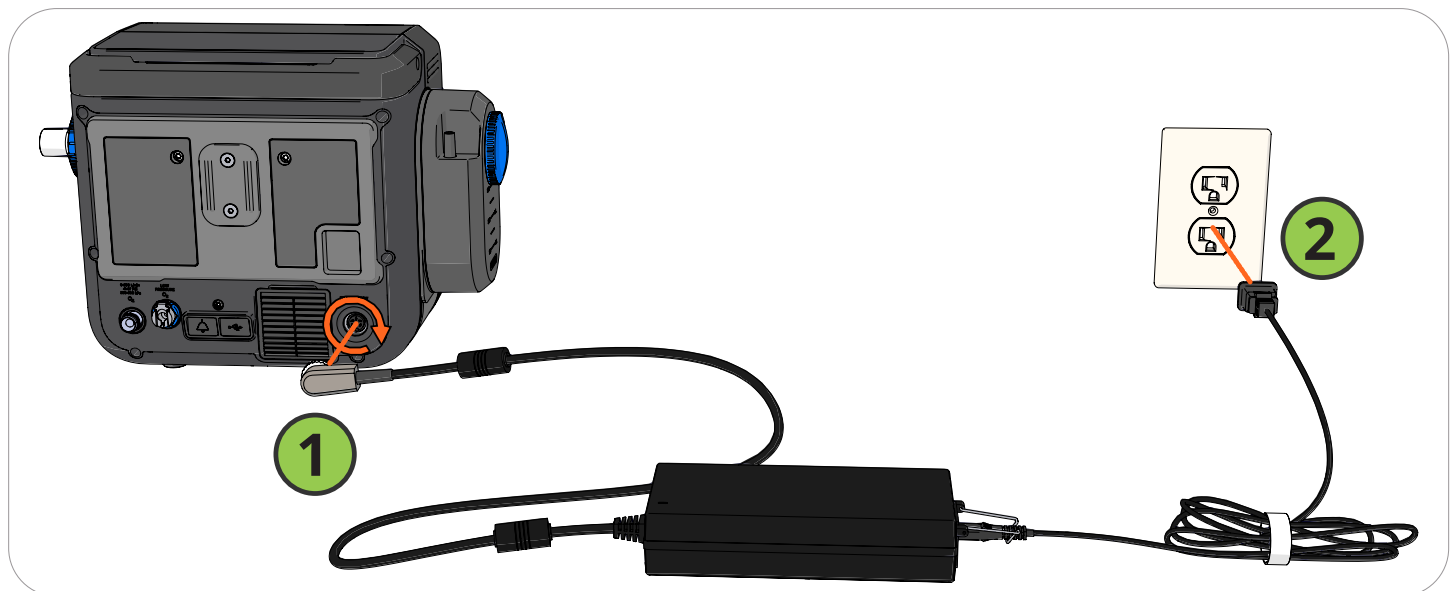



### Batteries

VOCSN comes with two removable, rechargeable batteries, and one internal battery. Depending on your settings, these three batteries together may power VOCSN for **up to nine hours**.



To remove a battery:

- 1** Lift the battery tab until it clicks.
- 2** Use the tab to remove the battery.

To connect a battery:

- 1** Lift the blue tab up, then insert the battery base-first.
- 2** Press the top of the battery into place and then press the blue tab down until it clicks and is flat against the battery.

The following VOCSN indicators provide information about battery status:

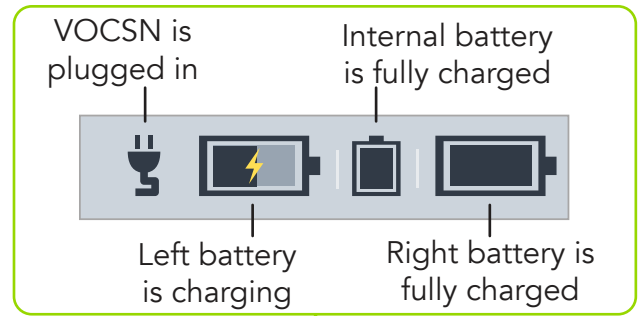

- Batteries are charging (orange)
- All batteries are fully charged (green)



## Connecting Patient Circuits

VOCSN may be connected to various circuit types available from Ventec Life Systems: Mouthpiece, or an Active, Passive, or Valveless Ventec One-Circuit.

### Connecting and Removing a Bacterial Filter

To connect a filter, fit it against VOCSN, aligning the tabs on the filter and VOCSN. Then, firmly twist the filter clockwise to lock it into place.

To remove a filter, firmly **push in on the filter** toward VOCSN and then twist it counterclockwise, aligning the tabs on the filter and VOCSN. Then, pull the filter to remove it.



### Mouthpiece Patient Circuits

Connect the Mouthpiece Circuit Kit components in the order depicted below.

- 1** Reducer cuff
- 2** 15mm circuit tubing (one piece)
- 3** Optional Mouthpiece Circuit Support Arm, available separately
- 4** Coupler
- 5** Flexible extension (optional)
- 6** Angled mouthpiece

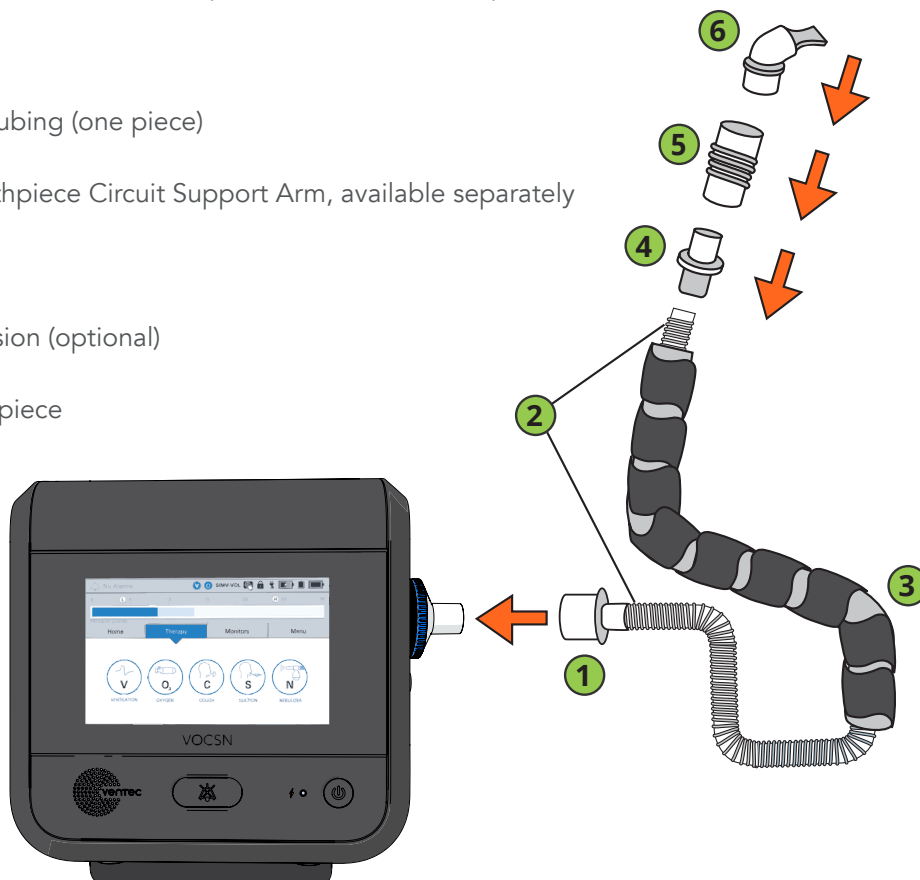

### Active, Passive, and Valveless Ventec One-Circuits

Connect patient circuit components in the order depicted below. For additional information, see the VOCSN Clinical and Technical Manual, available online at [VentecLife.com/VOCSNmanual](http://VentecLife.com/VOCSNmanual).

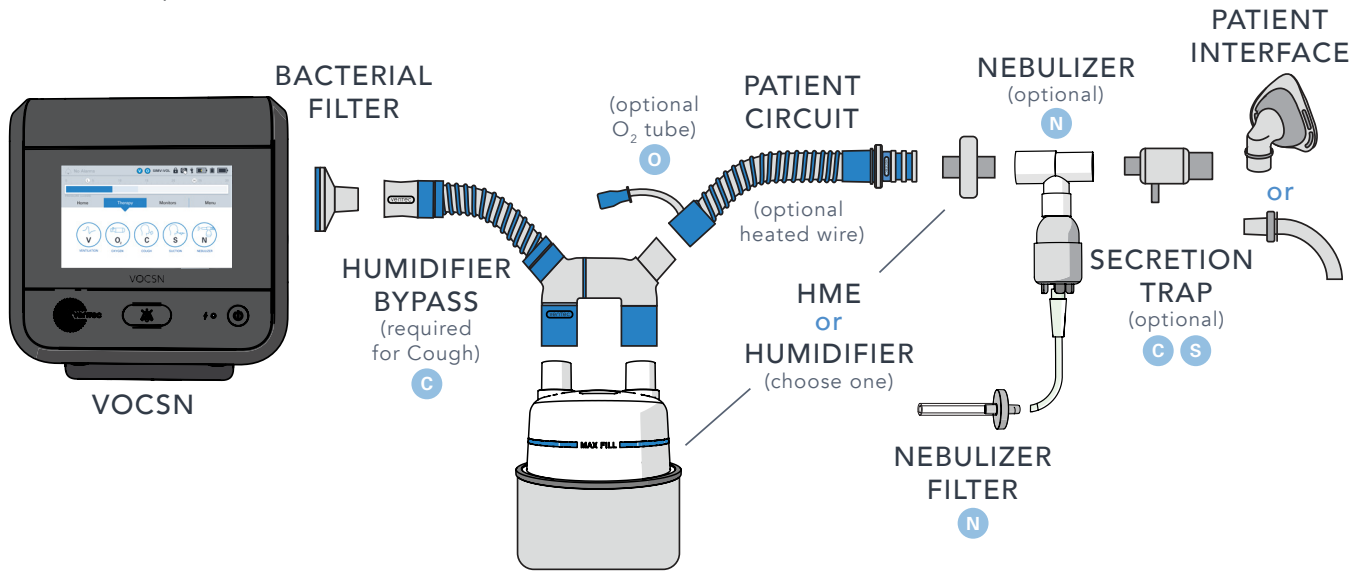

Item Name	Required?	Additional Information
VOCSN Bacterial Filter	Required	See "Connecting and Removing a Bacterial Filter" on page 10 for instructions.
Ventec Humidifier Bypass	Required for using Touch Button Cough therapy with a connected humidifier	The Ventec Humidifier Bypass prevents water damage to VOCSN during Cough therapy.
Humidifier	Optional	Include a form of humidification (either an HME or humidifier).
Active, Passive, or Valveless Ventec One-Circuit	Required	Use either an active, passive, or valveless Ventec One-Circuit. Ventec One-Circuits may include an integrated O2 tube for Oxygen Direct therapy and/or a heated wire. Active Ventec One-Circuits include flow sensor tubing.
Heat-Moisture Exchanger (HME)	Optional	Include a form of humidification (either an HME or humidifier).
Nebulizer and Nebulizer Filter	Optional	Connect a nebulizer to the nebulizer drive port.
Ventec Secretion Trap	Optional	Connect a Ventec Secretion Trap, using suction tubing, to a suction canister.
Patient Interface	Required	Examples of a patient interface include a mask or tracheal tube. Active and Passive Ventec One-Circuits include an exhalation valve and are intended for use with non-vented masks. Valveless Ventec One-Circuits are intended for use with vented masks.

### Connecting a Ventec One-Circuit O2 Tube

If your Ventec One-Circuit has an integrated O2 tube, connect the O2 tube to the oxygen output port on the right side of VOCSN. Fit the connection adapter around the port securely.

Note: To ensure proper Oxygen therapy performance, make sure the O2 tube is fully connected. The end of the blue connector should be flush against VOCSN.

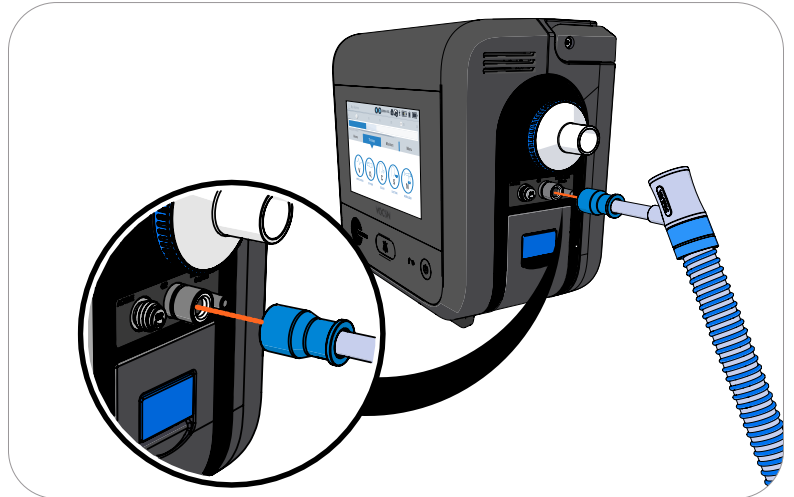

### Connecting an Active Ventec One-Circuit Multilumen Tube

- 1** Fit the oval connector tube into place in the Active connection port.
- 2** Fit the connecting screw cap over the port and twist it clockwise until it is firmly secured.

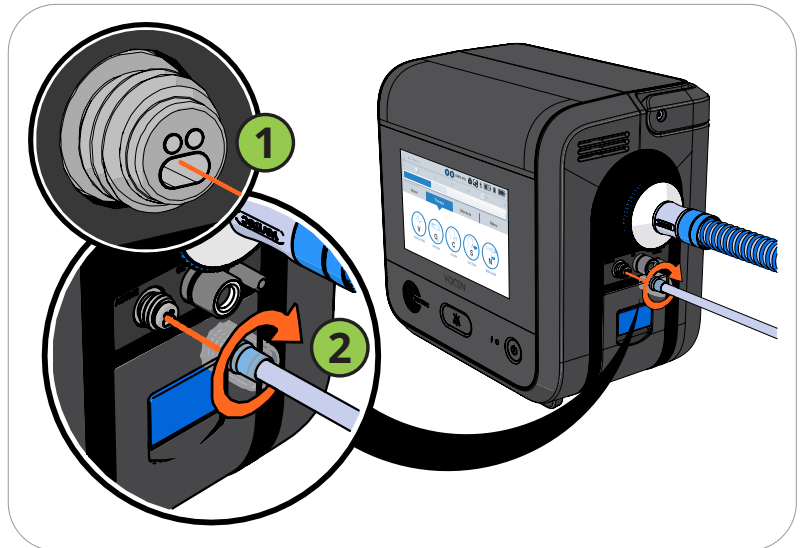

## The Pre-Use Test

To ensure therapy is delivered accurately, perform a Pre-Use Test whenever the patient circuit is changed or the device is powered on. If Ventilation therapy is critical to patient care, provide the patient with backup ventilation prior to initiating the Pre-Use Test.

Note: Though accuracy may be reduced, VOCSN may still be used to provide ventilation therapy without running the Pre-Use Test. If time constraints make running the test inadvisable, **press the EXIT button to immediately initiate Ventilation therapy.**

Some control changes cause VOCSN to prompt you to run a Pre-Use Test. You may also press the **Menu** tab and then the **PRE-USE TEST** button to begin a Pre-Use Test at any time. To run a Pre-Use Test, carefully follow the on-screen instructions. When instructed, use a clean, gloved hand to obstruct the circuit completely.

- If the test completes successfully, reconnect the Ventec One-Circuit to the patient and resume Ventilation therapy.
- If the test fails, inspect the Ventec One-Circuit configuration for leaks or improper setup. Resolve any issues with the Ventec One-Circuit, and then press **RESTART** to run the Pre-Use Test again.



# Changing Ventilation, Oxygen, and Cough Controls

Press the **Therapy** tab, and then the **Ventilation, Cough,** or **Oxygen** icon.

- 1 To configure a Preset, select it and then press the **SETTINGS** (or **SETTINGS & ALARMS**) button.

Any of the three available Presets can be configured by pressing the Preset tabs along the top of the configuration screen.

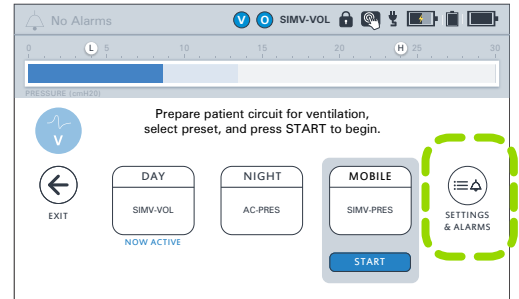

- 2 Scroll to the control you want to modify, select it and then press the **EDIT** button on the right side of the blue selection bar.

The **MODE**, and **CIRCUIT TYPE** controls cannot be modified while a Preset is active, and will appear in gray. If additional controls appear in gray, the **Clinician Access** passcode must be entered before modifying them.

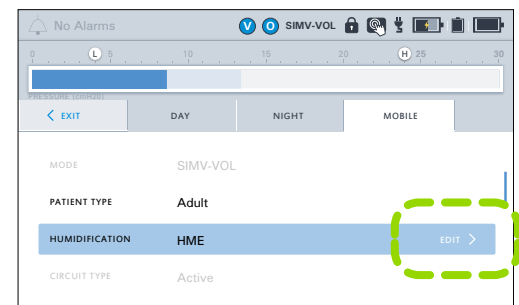

- 3 Enter the new selection and then press **ACCEPT** to confirm the change.

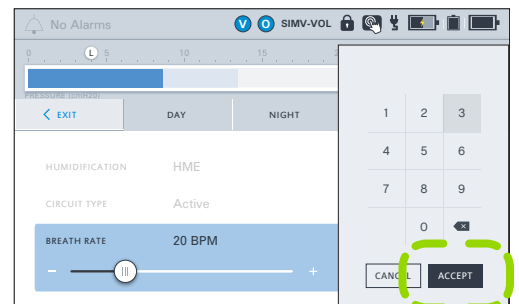

- 4 When configuration is complete, press the **EXIT** tab along the top of the screen.

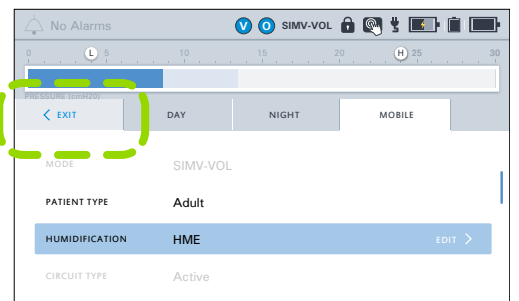

- 5 Activate or switch between configured presets at any time by selecting the appropriate Preset and then pressing **START**.

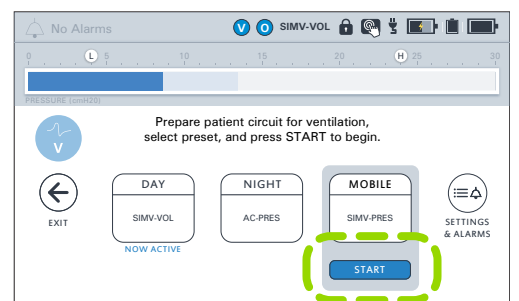

# Alarms

For a description of all available alarms and their settings, see the Clinical and Technical Manual, available online at [VentecLife.com/VOCSNmanual](http://VentecLife.com/VOCSNmanual).

## Setting Ventilation and Oxygen Alarms

Note: The High Pressure Delay and Patient Circuit Disconnect alarm settings can be used to help reduce nuisance alarms.

**1** To configure a alarms, select the Ventilation or Oxygen Preset you want to modify, and then press the **SETTINGS & ALARMS** button.

Any of the three available Presets can be configured by pressing the Preset tabs along the top of the configuration screen.

**2** Scroll past the controls to view alarms.

Find the name of the alarm you want to modify, select it and then press the **EDIT** button on the right side of the blue selection bar.

**3** If the alarm includes a Low and High setting:

- Select the **(L)** icon to adjust the Low alarm setting.
- Select the **(H)** icon to adjust the High alarm setting.

**4** If necessary, use the **OFF**  **ON** toggle to turn the alarm **ON**. Then, use the keypad to enter the desired setting.

**5** Press **ACCEPT** to confirm the new alarm setting(s).

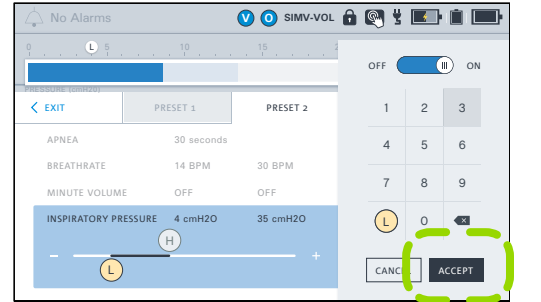
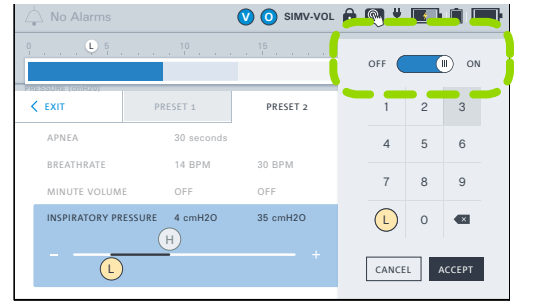
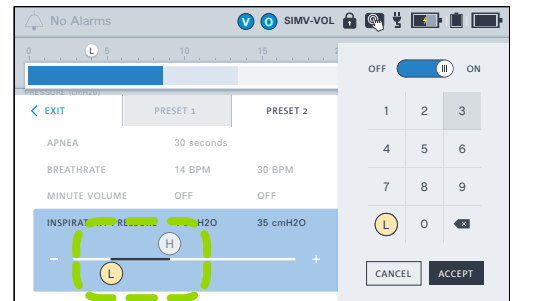
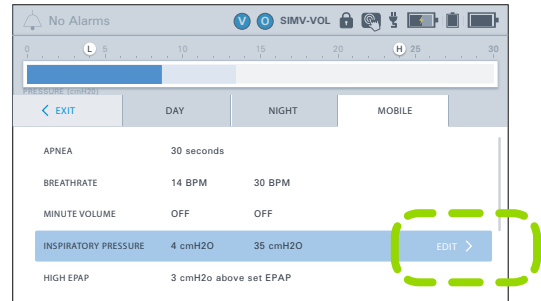
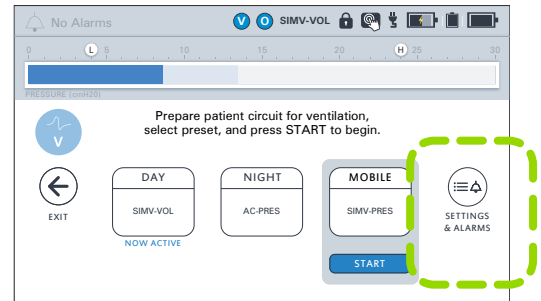

### Alarm Priorities

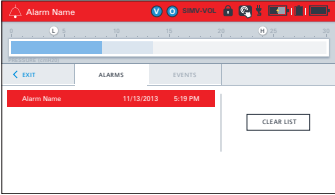
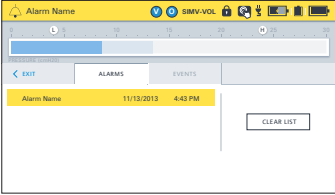
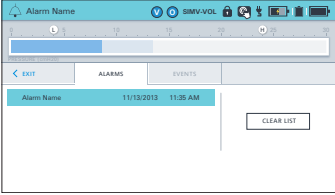
Alarm Priority	Visual Indicator	Auditory Indicator
High (red banner)		10 tones every 3 seconds
Medium (yellow banner)		3 tones every 7 seconds
Low (blue banner)		No auditory indicator

### Alarm and Event Logs

To view the VOCSN Alarm Log, press the alarm banner in the status bar, or press the **Menu** tab, and then the **LOGS** button.

To clear the list of all but the active alarm conditions, press the **CLEAR LIST** button from the Alarm Log screen.

### Silencing Alarms

To inactivate and reactivate alarm signals, use the Alarm Silence button on the front of VOCSN. The Alarm Silence button will silence the audible portion of VOCSN alarms for 60 seconds.



### Connecting a Nurse Call System or Remote Alarm

The remote alarm port is behind a protective rubber flap on the back of VOCSN. This port may be used to connect a remote alarm, a nurse call system, or other alarm systems that sense contact closure through a 1/4" phono jack, using the VOCSN Nurse Call Cable accessory (available separately from Ventec Life Systems).

Always test the alarm immediately after installation, and periodically during use to ensure it is functioning as intended.

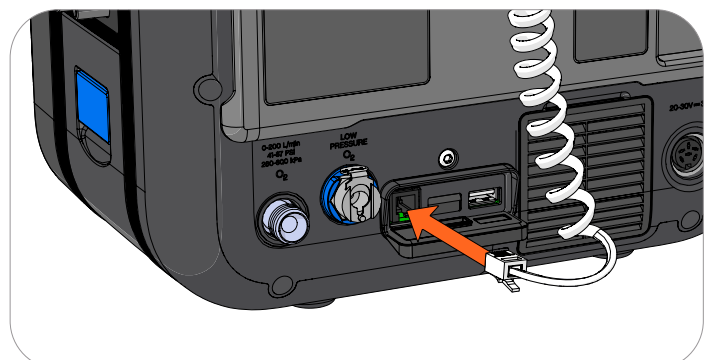

### Ventilation Therapy

To use Ventilation therapy, press the [Therapy](#) tab, and then the [Ventilation](#) icon.

Use the [Home](#) or [Monitors](#) tab to view monitored information about the delivered Ventilation therapy. The top row of Monitors displayed on the Monitors tab will also appear on the Home screen.

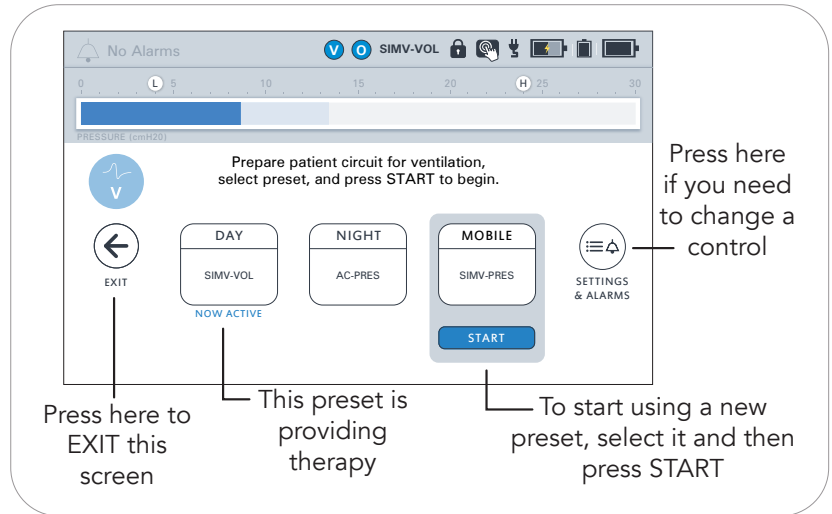

### Oxygen Therapy

Oxygen Direct therapy may be delivered from the internal O2 Concentrator in Pulse Dose mode (through an integrated oxygen tube inside the patient circuit). **The internal O2 Concentrator will deliver the equivalent of up to 6 L/min of oxygen without connecting an external oxygen source.**

With external high-pressure oxygen connected, Oxygen therapy may be delivered as either a Pulse Dose or FiO2. Additive low-pressure oxygen may also be used.

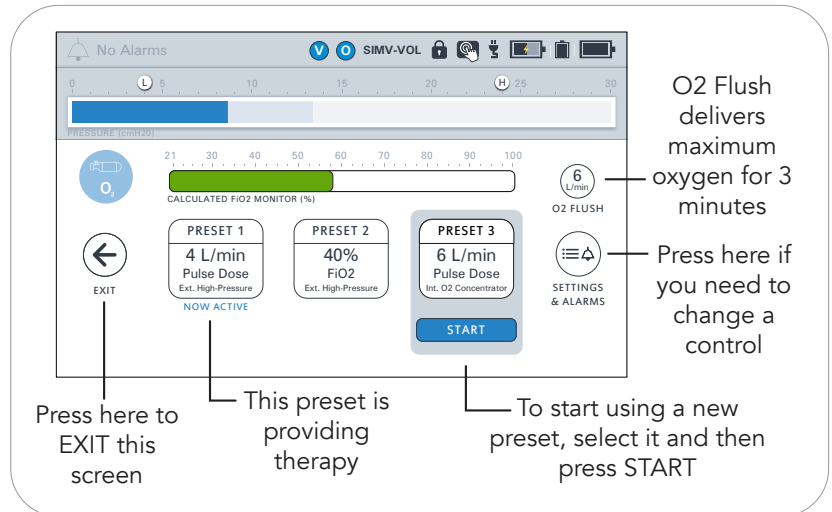

### Connecting External Oxygen

**External high-pressure oxygen** sources can be connected to VOCSN to provide Oxygen therapy in either Pulse Dose or FiO2 mode.

**External low-pressure oxygen** sources can be connected to VOCSN by using an O2 Low-Pressure Inlet Adapter (available separately from Ventec Life Systems). Oxygen from a low-pressure oxygen source is additive, and can be used in conjunction with oxygen from the internal O2 concentrator or an external high-pressure source. The flow of low-pressure oxygen is controlled by the oxygen source, not by the VOCSN oxygen controls.

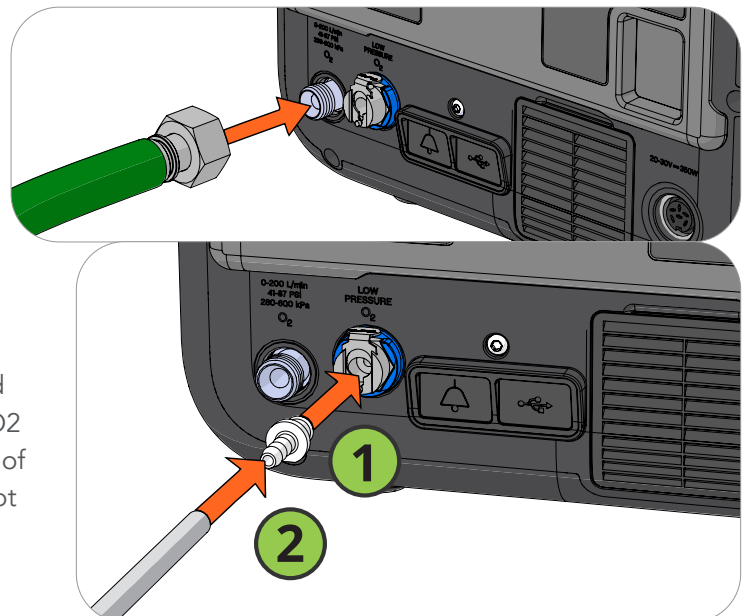



### Cough Therapy

To use Cough therapy, press the **Therapy** tab, and then the **Cough** icon.

If you are using a mask with an air leak in it for Ventilation therapy, change the mask to one without a leak for Cough therapy for the best results. When Cough therapy is complete, switch back to the vented mask.

The screenshot shows the Cough Therapy interface. At the top, it says 'No Alarms' and 'SIMV-VOL'. Below that is a pressure gauge and a bar graph. The main text reads: 'Prepare patient circuit for Cough therapy, select preset, and press START to begin.' There are three preset buttons: 'LOW -30 / +30 cmH2O Cough+Suction', 'MEDIUM -35 / +35 cmH2O', and 'HIGH -40 / +40 cmH2O'. A 'START' button is below the HIGH preset. There is also an 'EXIT' button and a 'SETTINGS' icon.

Callouts:

- Press here to EXIT this screen (points to the EXIT button)
- This preset has Cough + Suction enabled (points to the LOW and MEDIUM preset buttons)
- To start Cough therapy, select a preset and then press START (points to the START button)
- Press here to change controls (points to the SETTINGS icon)

### Suction Therapy

Oxygen therapy is paused during Suction therapy. See *"VOCSN Therapy Interactions"* on page 18 for more information.

To use Suction therapy, press the **Therapy** tab, and then the **Suction** icon.

Verify there are no leaks and that Suction therapy is functioning as intended by occluding the suction tubing or attached catheter with a clean, gloved hand. Observe the suction monitor (indicated by the solid fill inside the arc) and verify it matches the set vacuum value (displayed as a numeric value inside the arc, and a black line).

Once the **START** button is pressed, **Suction therapy may take up to 5 seconds to begin.**

The screenshot shows the Suction Therapy interface. At the top, it says 'No Alarms' and 'SIMV-VOL'. Below that is a pressure gauge and a bar graph. The main text reads: 'Prepare patient circuit for Suction therapy, select vacuum setting, and press START to begin.' There is a large gauge with a red arc and a black line. The gauge shows a value of 185 mmHg. There are '+' and '-' buttons for adjusting the vacuum, and a 'SET DEFAULT' button. A 'START' button is at the bottom.

Callouts:

- Press here to exit this screen (points to the EXIT button)
- Press here to start or stop Suction therapy (points to the START button)
- Press + and - to increase or decrease vacuum intensity (points to the '+' and '-' buttons)
- Press here to set the default Vacuum setting (It will also apply to Cough+Suction) (points to the SET DEFAULT button)

### Connecting a Suction Canister

To attach or detach the Suction Cap, Travel Canister, or External Canister Adapter twist them to the left (unlock and remove) or right (lock and suction).

### The Ventec Travel Suction Canister

The Ventec Travel Suction Canister has a **300 mL capacity**. If the canister overfills, or the knob gets wet during cleaning, a water-phobic filter will activate, suction will stop, and the canister filter will need to be replaced.

To empty the Travel Suction Canister, disconnect it, then twist the knob counterclockwise to the dot position, and pull the knob out of the canister.

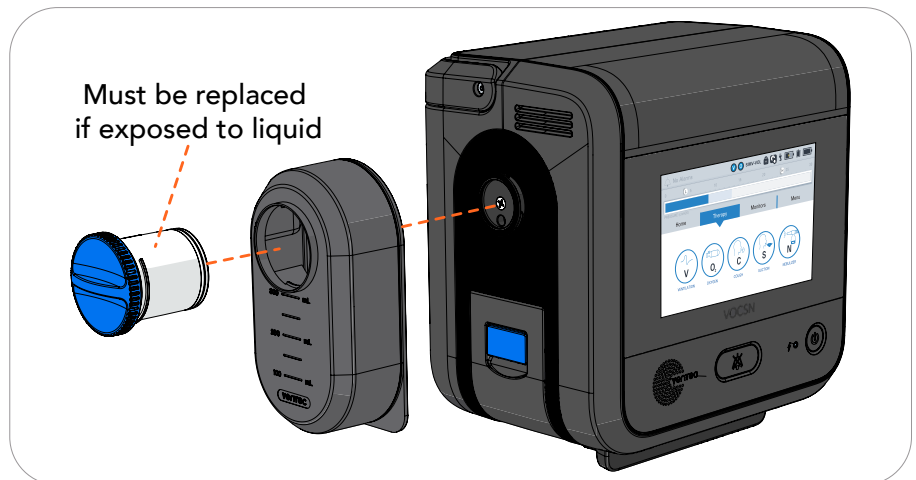
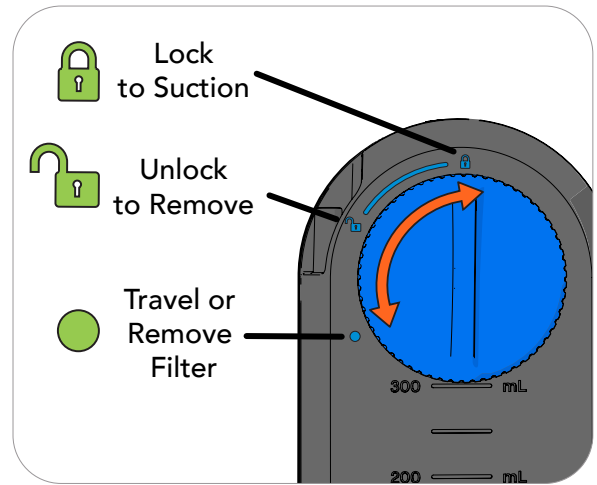

### The External Suction Canister Adapter (Sold Separately)

Use the External Suction Canister Adapter (available separately from Ventec Life Systems) to connect VOCSN to an external canister.

- 1** Attach the adapter by placing it against the suction port and twisting it to the lock position.
- 2** Connect 1/4" suction tubing to the canister
- 3** Connect suction tubing to the other port.



# Nebulizer Therapy

Note: **Oxygen therapy is paused during internal Nebulizer therapy.** See “VOCSN Therapy Interactions” on page 18 for more information.

## External Nebulizer Compensation

All VOCSN configurations can be used to compensate for the flow added to the patient circuit from an external 6 L/min. Follow instructions from the nebulizer manufacturer, and set the VOCSN Nebulizer Duration control using the plus (+) and (-) buttons. Press **START** underneath the **External Neb. Compensation** selection to begin compensation.

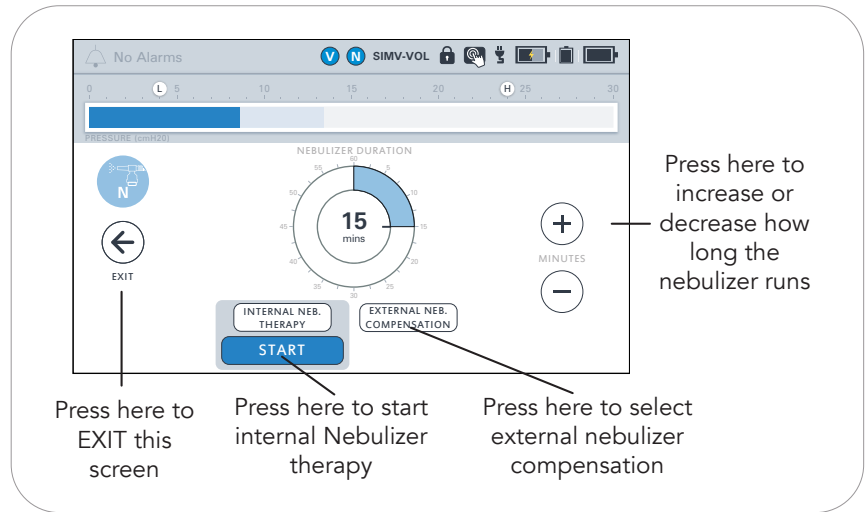

## Internal Nebulizer Therapy

VOCSN configurations that include a nebulizer may provide **Internal Neb. Therapy** from the Nebulizer port:

- 1 Connect a VOCSN Nebulizer Filter to the nebulizer port.
- 2 Connect one end of the nebulizer tubing to the VOCSN Nebulizer Filter, and the other end to the bottom of the nebulizer cup.
- 3 Add medication to the nebulizer cup by following all instructions from the nebulizer cup manufacturer.
- 4 Configure Nebulizer therapy. The Nebulizer Duration should be set to provide ample time for all medication in the cup to be delivered to the patient.
- 5 Before connecting the nebulizer cup to the patient circuit, select **Internal Neb. Therapy** and then press **START** to begin therapy. Confirm an aerosol mist is created from the nebulizer cup.
- 6 Attach the nebulizer cup and tee between the exhalation valve and the patient interface (or, if the tee is already in place, attach the nebulizer cup to it). Verify the nebulizer cup is vertical to ensure that all medication in the cup is properly nebulized.

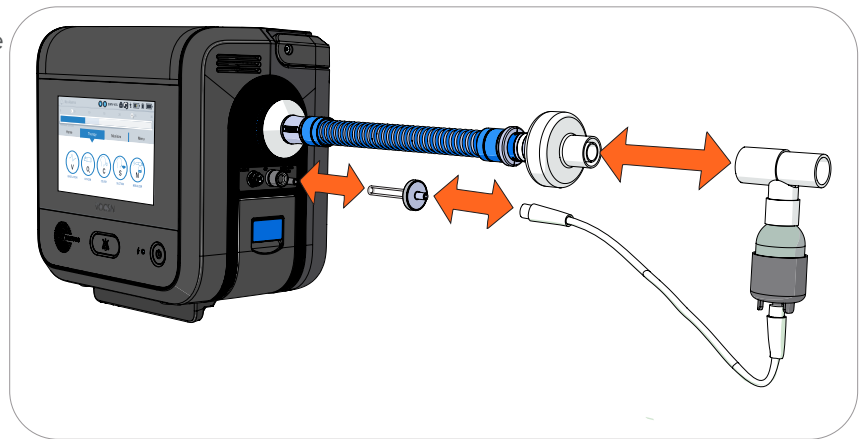

Note: If an HME is used, connect the nebulizer cup between the HME and the patient to prevent the HME from trapping nebulized medication. If a passive circuit is used, Ventec Life Systems recommends connecting a filter between the distal end of the circuit and the nebulizer tee to ensure nebulized material does not collect in the passive valve and obstruct airflow.

- 7 When nebulizer therapy is complete, disconnect the nebulizer from the Nebulizer Filter, and then from the patient circuit. Clean the nebulizer cup following all instructions from the nebulizer manufacturer.

# VOCSN Therapy Interactions

Only one of the following therapies can be delivered at a time: Oxygen, Suction, or Nebulizer. This page describes how starting a therapy affects each of the other active VOCSN therapies.

Note: It may take up to 5 seconds for a therapy to begin after pressing the **START** button.

**START**

Effect of Starting Another Therapy:

Running Therapy:		Oxygen (Pulse Dose)	Oxygen (FiO2)	Oxygen (Ext. Low-Pressure)	Cough	Suction	Nebulizer <sup>1</sup>
Ventilation	V	Therapies run simultaneously	Therapies run simultaneously	Therapies run simultaneously	Paused (automatically resumes)	Therapies run simultaneously	Therapies run simultaneously
Oxygen (Pulse Dose)	O	N/A	Ended	Therapies run simultaneously	Paused (automatically resumes)	Paused (automatically resumes)	Paused (automatically resumes)
Oxygen (FiO2)	O	Ended	N/A	Therapies run simultaneously	Therapies run simultaneously	Paused (automatically resumes)	Paused (automatically resumes)
Oxygen (Ext. Low-Pressure)	Controlled by Oxygen Source	Therapies run simultaneously	Therapies run simultaneously	N/A	Therapies run simultaneously	Therapies run simultaneously	Therapies run simultaneously
Cough	C	N/A	N/A	Therapies run simultaneously	N/A	Therapies run simultaneously with Cough + Suction feature	N/A
Suction	S	Ended	Ended	Therapies run simultaneously	Therapies run simultaneously	N/A	Ended
Nebulizer*	N	Ended	Ended	Therapies run simultaneously	Paused (automatically resumes)	Ended	N/A

## Maintaining Oxygenation During Nebulizer or Suction

If it is critical to patient care, the following approaches may be used to maintain patient oxygenation while Oxygen therapy is paused during Nebulizer and Suction therapies:

- Use the VOCSN O2 Flush feature to oxygenate the patient before providing Nebulizer or Suction therapy.
- Use an external nebulizer or suction machine to provide the therapy. When using an external nebulizer, use the External Neb. Compensation feature to minimize nuisance alarms.
- Use an external source of low-pressure oxygen during Nebulizer or Suction therapy. Low-pressure oxygen flowing through VOCSN and into the patient circuit is additive, and is not paused by Nebulizer or Suction therapy.

<sup>1</sup> This table describes the effects of internal Nebulizer therapy. External Nebulizer Compensation does not cancel or pause any other active therapy. If you are using an external nebulizer, disconnect it and stop nebulizer compensation before starting Cough therapy to prevent nebulized material from reaching VOCSN.

# Comparable Ventilation Modes

VOCSN provides a comprehensive set of ventilation modes to meet patient needs. The reference tables below illustrate how to set your preferred ventilation mode.

## Non-Invasive Ventilation Modes

Ventilation Mode or Feature	Equivalent VOCSN Mode Settings	Additional VOCSN Controls
<b>S/T</b> (Spontaneous/Timed)	<ul style="list-style-type: none"> <li>Set Mode to Bi-Level</li> <li>Set Backup Rate</li> <li>Set Flow Trigger</li> </ul>	<ul style="list-style-type: none"> <li>Inspiratory Time, EPAP, IPAP (measured from a baseline of 0 cmH<sub>2</sub>O), Flow Cycle, Time Cycle, Rise Time</li> </ul>
<b>AVAPS™</b> (Average Volume Assured Pressure Support) <b>PRVS</b> (Pressure Regulated Volume Support)	<ul style="list-style-type: none"> <li>Set Mode to Vol. Targeted-PS</li> <li>Set Backup Rate (active and passive circuits only)</li> <li>Set Pres. Minimum and Pres. Adj. Rate</li> <li>Set Flow Trigger</li> <li>Set High Pressure Alarm 5 cmH<sub>2</sub>O above desired maximum IPAP</li> </ul>	<ul style="list-style-type: none"> <li>Inspiratory Time and EPAP (active and passive circuits only), Tidal Volume, Pressure Control Flow Termination Flow Cycle, Time Cycle, Rise Time</li> </ul>
<b>T</b> (Timed)	<ul style="list-style-type: none"> <li>Set Mode to AC-Pressure</li> <li>Set Backup Rate</li> <li>Set Flow Trigger to Off</li> <li>Set Pressure Control Flow Termination to Off</li> </ul>	<ul style="list-style-type: none"> <li>Inspiratory Time, PEEP, Pressure Control (measured above the set PEEP), Rise Time</li> </ul>
<b>Pressure Support</b> <b>S</b> (Spontaneous)	<ul style="list-style-type: none"> <li>Set Mode to SIMV-Pressure or SIMV-Volume</li> <li>Set Breath Rate to 0</li> <li>Set Pressure Support</li> </ul>	<ul style="list-style-type: none"> <li>Inspiratory Time (Apnea backup), Pressure Control (Apnea backup if SIMV-Pressure), Tidal Volume (Apnea backup if SIMV-Volume), PEEP, Flow Cycle, Time Cycle, Rise Time, Apnea Rate</li> </ul>
<b>CPAP</b> (Continuous Positive Airway Pressure)	<ul style="list-style-type: none"> <li>Set Mode to SIMV-Pressure or SIMV-Volume</li> <li>Set Breath Rate to 0</li> <li>Set PEEP to desired CPAP level</li> <li>Set Pressure Support to 0</li> </ul>	<ul style="list-style-type: none"> <li>Inspiratory Time (Apnea backup), Pressure Control (Apnea backup if SIMV-Pressure), Tidal Volume (Apnea backup if SIMV-Volume), Flow Cycle, Time Cycle, Rise Time, Apnea Rate</li> </ul>

### Volume Ventilation Modes

Ventilation Mode or Feature	Equivalent VOCSN Mode Settings	Additional VOCSN Controls
<b>AC-Volume</b> (Assist/Control)	<ul style="list-style-type: none"> <li>Set Mode to AC-Volume</li> <li>Set Breath Rate</li> <li>Set Flow Trigger to On</li> </ul>	<ul style="list-style-type: none"> <li>Inspiratory time, Tidal Volume, PEEP, Sigh</li> </ul>
<b>VC</b> (Volume Control)		
<b>SIMV-Volume or SIMV</b> (Synchronized Intermittent Mandatory Ventilation)	<ul style="list-style-type: none"> <li>Set Mode to SIMV-Volume</li> <li>Set Breath Rate</li> <li>Set Flow Trigger</li> <li>Pressure Support (measured above the set PEEP)</li> </ul>	<ul style="list-style-type: none"> <li>Inspiratory Time, Tidal Volume (for mandatory breaths), PEEP, Flow Cycle, Time Cycle, Rise Time, Apnea Rate, Sigh</li> </ul>
<b>+/- Pressure Support</b>		
<b>CV-Volume</b> (Control Ventilation)	<ul style="list-style-type: none"> <li>Set Mode to AC-Volume</li> <li>Set Breath Rate</li> <li>Set Flow Trigger to Off</li> </ul>	<ul style="list-style-type: none"> <li>Inspiratory time, Tidal Volume, PEEP, Sigh</li> </ul>

### Pressure Ventilation Modes (Including Volume-Targeted)

Ventilation Mode or Feature	Equivalent VOCSN Mode Settings	Additional VOCSN Controls
<b>AC-Pressure</b> (Assist/Control)	<ul style="list-style-type: none"> <li>Set Mode to AC-Pressure</li> <li>Set Breath Rate</li> <li>Set Flow Trigger</li> </ul>	<ul style="list-style-type: none"> <li>Inspiratory Time, PEEP, Pressure Control (measured above the set PEEP), Pressure Control Flow Termination, Flow Cycle, Rise Time</li> </ul>
<b>PC</b> (Pressure Control)		
<b>PRVC</b>  (Pressure Regulated Volume Control)	<ul style="list-style-type: none"> <li>Set Mode to Vol. Targeted-PC</li> <li>Set Breath Rate</li> <li>Set Pres. Minimum and Pres. Adj. Rate</li> <li>Set Flow Trigger</li> <li>Set High Pressure Alarm 5 cmH2O above desired maximum PIP</li> </ul>	<ul style="list-style-type: none"> <li>Inspiratory Time, Target Volume, PEEP, Pressure Control Flow Termination, Flow Cycle, Rise Time</li> </ul>
<b>SIMV-Pressure or PC-SIMV</b> (Synchronized Intermittent Mandatory Ventilation)	<ul style="list-style-type: none"> <li>Set Mode to SIMV-Pressure</li> <li>Set Breath Rate</li> <li>Set Flow Trigger</li> </ul>	<ul style="list-style-type: none"> <li>Inspiratory Time, PEEP, Pressure Control Flow Termination, Flow Cycle, Time Cycle, Rise Time</li> </ul>
<b>+/- Pressure Support</b>	<ul style="list-style-type: none"> <li>Set Pressure Control</li> <li>Set Pressure Support (measured above the set PEEP)</li> </ul>	
<b>SIMV + PRVC</b> (Synchronized Intermittent Mandatory Ventilation) + (Pressure Regulated Volume Control)	<ul style="list-style-type: none"> <li>Set Mode to Vol. Targeted-SIMV</li> <li>Set Breath Rate</li> <li>Set Pres. Minimum and Pres. Adj. Rate</li> <li>Set Flow Trigger</li> <li>Set High Pressure Alarm 5 cmH2O above desired maximum PIP</li> </ul>	<ul style="list-style-type: none"> <li>PEEP, Tidal Volume, Pressure Support (measured above the set PEEP), Inspiratory Time, Pressure Control Flow Termination, Flow Cycle, Time Cycle, Rise Time</li> </ul>

# VOCSN Controls Setup

Ventilation Control	Ventilation Setting			Ventilation Alarm	Ventilation Alarm Setting		
	Preset 1	Preset 2	Preset 3		Preset 1	Preset 2	Preset 2
Preset Label				Apnea			
Mode				Low Breath Rate			
Patient Type (Adult or Pediatric Circuit)				High Breath Rate			
Humidification (Humidifier or HME)				Low Minute Volume			
Circuit Type				High Minute Volume			
Breath Rate (or Backup Rate)				Low Inspiratory Pressure			
Inspiratory Time				High Inspiratory Pressure			
High Flow							
Tidal Volume				High PEEP			
Pres. Adj. Rate				Low PEEP			
Pres. Minimum				Patient Circuit Disconnect			
Flow Trigger							
Pressure Control				High Pressure Delay			
Pressure Support							
IPAP				<b>Cough Control</b>	<b>Cough Setting</b>		
PEEP or EPAP					Preset 1	Preset 2	Preset 3
PC Flow Termination				Preset Label			
Flow Cycle				Insufflation Pressure			
Time Cycle				Exsufflation Pressure			
Rise Time				Insufflation Time			
Leak Compensation				Exsufflation Time			
Sigh				Pause Time			
Apnea Rate				Insufflation Rise Time			
<b>Oxygen Controls and Alarms</b>	<b>Oxygen Settings</b>			Cough Cycles			
	Preset 1	Preset 2	Preset 3	Breath Sync			
Preset Label				Cough + Suction			
Oxygen Source				<b>Suction and Nebulizer Controls</b>	<b>Suction and Nebulizer Settings</b>		
Oxygen therapy (in L/min or FiO2)					Suction (Vacuum in mmHg)		
Low FiO2 Alarm				Nebulizer (Duration)			
High FiO2 Alarm							



## About Ventec Life Systems

Ventec Life Systems is defining integrated respiratory care to improve patient outcomes and reduce caregiver challenges in the hospital and home. Ventec's leading product, VOCSN, seamlessly integrates five separate devices including a ventilator, oxygen concentrator, cough assist, suction, and nebulizer into one unified respiratory system. The team's history of patient-centric design brings care changing innovations to life for patients, medical professionals, and caregivers.

### For questions about VOCSN:

VentecLife.com  
info@venteclife.com  
1-844-MY-VOCSN

