



**Model SH-2012AH-QG
(V5.0-1.0)
CNC
Cutting Machine**

User's Manual

<u>Contents</u>	_____
<u>Functional Overview</u>	_____
<u>Main Menu</u>	_____
<u>AUTO</u>	_____
<u>MAN</u>	_____
<u>EDIT</u>	_____
<u>Command System</u>	_____
<u>SETUP</u>	_____
<u>LIBMINIT</u>	_____
<u>DIAGNOSE</u>	_____
<u>I/O Interface</u>	_____
Appendix	
1. <u>Pin definitions of height controller</u>	
2. <u>SH-2012AH-QG Software</u>	
<u>Upgrading Instructions</u>	
3. <u>Installation Dimensional Diagrams</u>	_____
4. <u>Troubleshooting</u>	_____
5. <u>Wiring Instructions of Extended</u>	
<u>Manual Control Box</u>	



版权所有

未经特别授权，禁止对文件进行传播或复制，禁止对其内容进行商业宣传或通讯。违反这些条例将要对此进行赔偿。所有版权归公司所有。

拒绝承担责任的声明

已经对打印文件的内容与所描述的产品之间进行了一致性检查。由于不可能完全消除不准确性，因此不能保证绝对准确。将对文件中的信息作定期检查并且在以后的修订中进行必要的修改。非常乐意接受改进建议。公司保留在技术修改或改进的基础上进行相应修改的权利。

All rights reserved

Forbidden to distribute or duplicate any file for the purpose of commercial, communication or others without particular authorization. Compensation will be incurred if any clause is violated. All rights belong to Beijing Start Microstep Control Technology Co., Ltd.

Disclaimer

We have made a consistency inspection to the contents of the printed file against the product described. However, we can't guarantee absolute accuracy due to the impossibility to eliminate inaccuracy completely. Nevertheless, we will verify the information in the file regularly and make necessary amendments in the revised version. Any suggestion for later improvement is greatly appreciated. Microstep reserves all the rights to make necessary amendments on the basis of technical improvement.

Please Read This Manual Carefully Before Operating The System.

Precautions

1. After the container is unpacked, please check the system for any damage and verify if the contents in the container are physically in conformance with the packing list.
2. This user's manual is applicable to Model SH-2012AH-QG CNC System for Cutting manufactured by Microstep Control Technology Co., Ltd.
3. Please verify the conformance of local mains voltage. Be sure to use an AC220V isolation transformer between the power supply network and the system to guarantee personal safety and operating reliability.
4. The required ambient temperature for the CNC is ranged from 0°C to +40°C and the relative humidity is from 0 to 85%.
Special protection is required in case of operating in a high temperature, high humidity or corrosive gas environment.
5. Make sure the CNC is correctly wired and securely grounded.
6. Never try to hot plug/unplug any cable on the rear panel of the CNC, for the damage incurred thereby is beyond our quality warranty.
7. No cable from the output port of the rear panel should be shorted with any power cable; otherwise, the CNC might be burned.
8. Working in a very dusty environment, the whole system should be provided with dust protection in addition to regular dust cleaning.
9. Trained operator should be specially assigned for the CNC.
10. The internal AC/DC power supply dedicated for the CNC should never share with any other electric appliance.
11. The graphic programming software installed in the system is a beta version asking for advices, which is subject to improvement in service and not taken as a requisite function and item for acceptance. Please advise us timely in case of any debug in your use.
12. Please contact the manufacturer in case of any problem. Never disassemble, assemble or modify the system the system without prior authorization and qualification.
13. Be sure to maintain the system and the cutting machine properly--routine maintenance and check per shift, secondary maintenance per month and primary maintenance half a year.
14. Set the parameters in strict accordance with this user's manual or the supplemental instructions given at placing order. The CNC might poorly function or even be damaged if the parameters are set beyond the range.
15. The LCD screen is fragile and proper care is necessary in the process of operation.
16. The technical specifications are subject to change without prior notice.
17. **Attention:**
The provided USB port is very small in power output, only good for USB disk and not recommended for any other USB device to prevent damage.
18. The system power must be cut off when alternating the internal keyboard and an extended keyboard.
19. **Special Statement:**
The quality warranty of this product is twelve months since its manufacturing date covering the faults specified by this user's manual.
Paid service is available for faults caught beyond the warranty period and outside the quality warranty coverage.
The following cases are not covered by the manufacturer's quality warranty:
A: Damage caused by misuse due to violating the operating instructions, and
B: Damage due to force majeure,
The force majeure is generally inclusive of two cases:
Natural causes such as thunderstroke, flood, drought, snowstorm, earthquake, etc.
Society causes such as war, strike, government prohibition, etc.
C: Damage caused by unauthorized actions such as disassembly, modification, repair, etc.
20. The final power of interpretation to this user's manual is subject to Beijing Start Microstep Control Technology Co., Ltd.

Contents

Chapter I. Functional Overview	1
1.1. System Functions	1
1.2. Technical specifications	1
1.3. Microstep also supplies the following auxiliary products for compact CNC cutting machine.....	2
Chapter II. Main Menu	3
2.1. Menu Features	3
2.2. Description of Main Menu	3
Chapter III. Automatic Function(AUTO)	3
Chapter III. Automatic Function(AUTO)	4
3.1. Description of Automatic Mode Window	5
3.2. Function selection in AUTO mode	6
3.3. Startup of speed mode(multiplying factor) and automatic mode	8
3.4. Control and adjustment of cutting position in automatic mode	8
3.5. Original Path Return	10
3.6. Breakpoint Restoration Process	11
3.7. SECTION(section selection)	11
3.8. MOVE HOLE for Thick Plate	12
Chapter IV. MAN(Manual Mode)	14
4.1. Description of Manual Mode Window	14
Chapter V. EDIT Mode	16
5.1. Description of EDIT Menu	16
Chapter VI. Command System	18
6.1. Description of Programing Symbols	18
6.2. Coordinate System	18
6.3. G: Basic Preparatory Commands	19
6.4. M Auxiliary Commands	23
Chapter VII. SETUP(Parameter Setting)	25
7.1. Parameter Description	25
7.2. SETUP(parameter setting)	26
7.3. Flame Cutting Parameters	28
7.4. Plasma Parameters Setting	29
7.5. Control Parameters Setting	30
7.6. Control Parameters Setting of Height Controller	31
Chapter VIII. LIBMINIT(Library of Patterns)	32
8.1. LIBMINIT Setting	32
8.2. Selection of Pattern Elements	32
8.3. Arrangement and Layout of Pattern Element	33
8.4. User Defined Module	34
Chapter IV. Diagnose	35
9.1 Check Input/output Ports	35
9.2 Output Check	35
9.3 Input Check	35
Chapter X. Connections of Input/output Ports	36
10.1. System Input Principle	36
10.2. System Output Principle	36
10.3 Definitions of Input/Output Ports	37
10.4 Definitions of 15-pin Ports for Motor	39

10.5 Typical Wiring for Flame Cutting Operation(DB15)	39
10.6 Typical Wiring for Plasma Arc Cutting Operation	40
10.8 Pin Definitions	41
Appendix I: The Wiring Diagram and Pin Definitions for Model SH-HC30 Height Controller Manufactured by Microstep	43
Appendix II: Instructions for Software Upgrading Operation of SH-2012AH	45
Appendix III: Installation Dimensional Drawing	46
Appendix IV: Troubleshooting	47
Appendix V: Wiring Instructions for Extended External Manual Control Box	50

Chapter I. Functional Overview



1.1. System Functions

- Model SH-2012AH-QG CNC System for Cutting is designed to work with torch/plasma, high-pressure water jet and laser cutting machines and extensively used in metal working, advertisement fabrication and stone machining businesses.
- High reliability as well as good resistance to plasma disturbance, lightning and surge.
- Applied torch/plasma cutting technology, able to perform corner speed control and height control automatically;
- Kerf compensation, reasonability check and report for user's option;
- Breakpoint restoration, automatic power-back recovery and automatic breakpoint memory,
- Random section and piercing point selection,
- Extended piercing for thick plate and bridging feature for thin plate,
- Optional piercing position feature in mode of RETURN, SECTION(section selection) and RESBREK(breakpoint restoration), very convenient for user control,
- Ready for transitional cutting operation at any moment,
- Special short line machining feature based on smooth travel, extensively applicable to metal blanking as well as advertisement and ironwork fabrication, etc.
- Parts library of 24-type patterns, extensible and customizable, including the common machining parts,
- Compatible with many blanking software such as IBE(Germany), FASTCAM, etc.
- Operation menu both in Chinese and English, dynamic graphic display, 8-times zoom, free point automatic tracking, USB disk program and timely software upgrade.

1.2 Technical specifications

- Processor: Industrial ARM7 CPU
- Display: 7" Color LCD
- Input/output: 13 channels of optical isolation input and 8 channels of optical isolation output
- Interlocked axles: 2 axles, extensible to 4 interlocked axles
- Maximum speed: <24m/min
- Pulse equivalency: variable, electronic gear numerator and optional denominator in the range from 1 to 65535
- Memory space: 32M-64M oversized memory capacity for user program and no restriction to machining program
- Machine case size: 298×202×95.2(mm)
- Operation temperature: 0 to +40°C; storage temperature: -40 to +60°C

1.3 Microstep also supplies the following auxiliary products for compact CNC cutting machine.



Chapter II. Main Menu

2.1. Menu Features

The design of hierarchy-based functional windows is adopted for system operating display. If a function is invoked in the main menu window, the corresponding subwindow menu will pop up. Press [F1] to [F7] to select the corresponding function according to window prompt. Press ESC to abandon the selection and return to the upper level of menu.

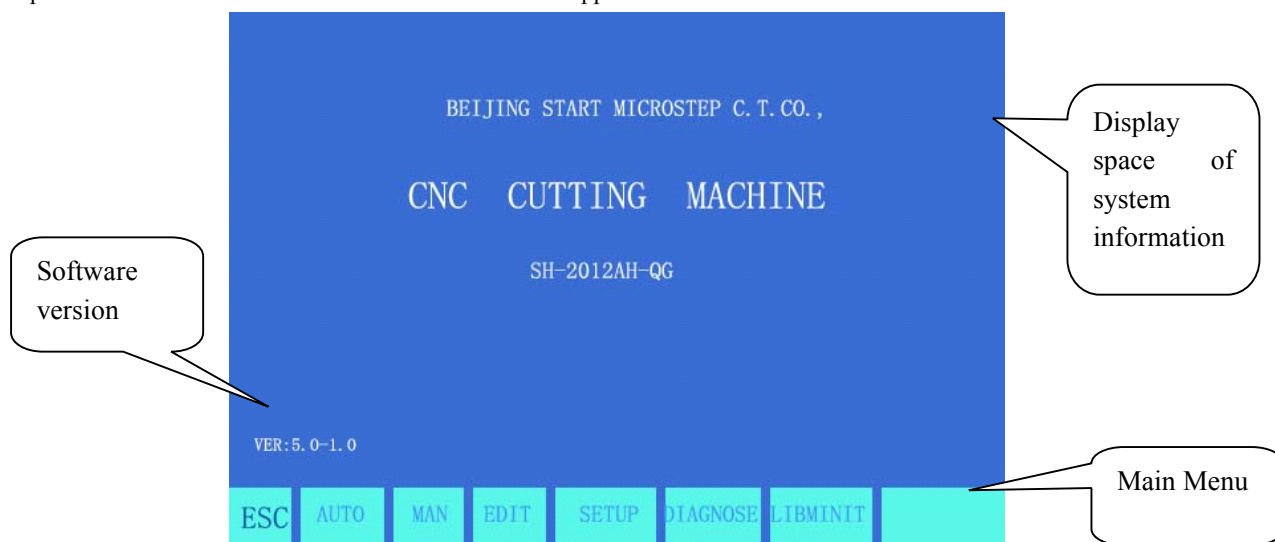

Fig. 2.1 Main menu display of system after booting

2.2. Description of Main Menu

VER : The version information of software and hardware is indicated at the bottom left corner for your information.

[F1] AUTO : Programmed control of automatic machining

[F2] MAN : To manually control the position of cutting nozzle

[F3] Edit : To edit/modify/input/output the machining program

[F4] SETUP : To set system parameters

[F5] DIAGNOSE : To check the input/output information of cutting machine

[F6] LIBMINIT : To set normal pattern and plan material

[G] [G] [3] Initial Setting : A dialog box as follows will appear:

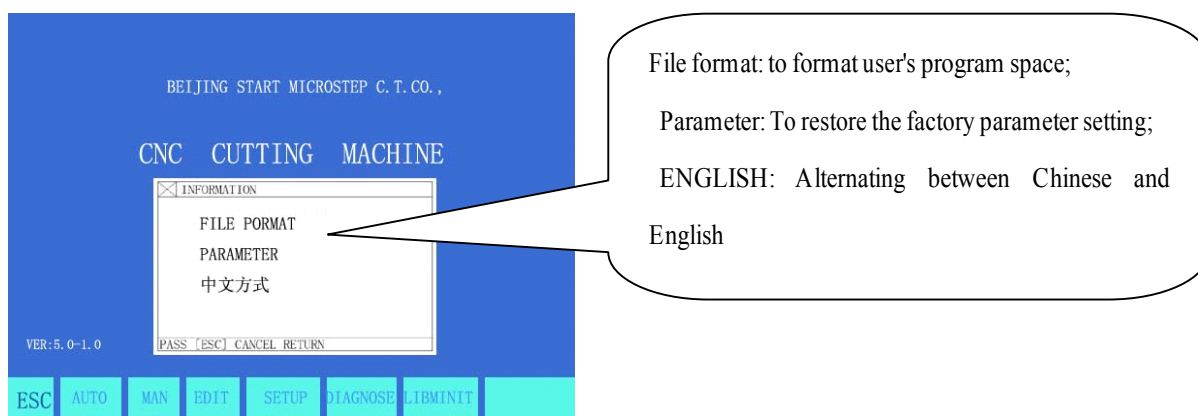

Fig. 2.2 Initial setting dialog box

Chapter III. Automatic Function(AUTO)

In the main menu, press [F1] to enter the automatic function window, as shown in the figure below.

Active speed multiplying factor

Program name

Piercing Hole No.

Kerf

Heavy-current control output

Function keys

Input/output indication

Machining parameter indication

Pattern Display Space

Coordinates

Machining program

Work mode

Plasma Mode

Flame mode

Fig. 3.1 Automatic Function (AUTO) Window

3.1. Description of Automatic Mode Window

3.1.1 SPEED

- 1) In automatic mode, at the top left corner of the screen, it shows $F \times (\text{multiplying factor of automatic machining speed}) = \text{set machining speed}$.
- 2) In manual mode, at the top left corner of the screen, it shows $F \times (\text{multiplying factor of manual speed}) = \text{manual speed}$.
- 3) SPEED indicates the actual speed while the active speed multiplying factor is adjustable with [F↑] and [F↓].
- 4) It is allowed to adjust the speed quickly by pressing [F] key in this window. A pull-down menu will appear with 8 speed multiplying factors available for selection with [↑] and/or [↓] key: 5%, 20%, 30%, 40%, 50%, 60%, 80% and 100%. And then, press ENTER key to acknowledge the selection.
- 5) **Attention:** The speed may be indicated in **Metric** or **English** system depending on the Metric/English Selection in **SETUP** (Refer to **Parameter Control**).

3.1.2 PROG, PIERCE and KERF

They are used to indicate the name of machining program, serial number of pierced hole (automatic clear in automatic machining mode) and the active compensating width of kerf respectively.

3.1.3 WORKMODE, OPERATE

WORKMODE field indicates the active operating mode such as rotation selection, breakpoint recovery, mirroring and section selection.

OPERATE field indicates such information as machining/pause, limit alarms and time delay.

3.1.4 Input and output

Below the heavy-current switches, there are 3 rows \times 8 indicators \circ .

The top indicators show the status of 13 input ports, \circ indicating no signal input and \bullet indicating signal input.

The bottom indicators show the status of 8 output ports, \circ indicating no signal output and \bullet indicating signal output.

See the description of **DIAGNOSE** function for the definitions of input/output ports.

3.1.5 Machining Parameters Indication

This zone indicates various parameter values in the current machining mode.

3.1.6 Selection of coordinate unit

The coordinates may be indicated in **Metric** (millimeter) or **English** system (inch) depending on the Metric/English Selection in SETUP (Refer to Parameter Control).

3.1.7 The **six heavy-current control keys** on the front panel are designed to exert heavy-current control of external source.

[IGN]: Refer to M20 for ignition feature.

[PREHEA]: To open the solenoid valve of preheating oxygen. Refer to M24 for details.

[GAS]: To open the solenoid valve of acetylene (gas). Refer to M10 for details.

[CUT]: To open the solenoid valve of cutting oxygen; refer to M12 for details. To turn on the arcing switch if it is **plasma**.

[PIERCE] heavy-current control key

To carry out a piercing process, the specific operation procedure is as follows:

Flame machining case: rise the cutting torch (M72), open the cutting oxygen (M12) and lower the cutting torch (M73).

Plasma machining case: execute M07 command.

Note: This is a very important feature. It will be used repeatedly in pause, return and extend piercing operations. When preheat is done, pressing [PIERCE] key will start up piercing operation directly.

[SWOFF]: To shut off all the heavy-current output.

[S ↑]: Push it down to rise the cutting torch and release to stop the torch.

[S ↓]: Push it down to lower the cutting torch and release to stop the torch. ;

3.1.8[1] BLOWUP

The pattern will be magnified one times by one keystroke and it can be magnified to eight times maximum by three keystrokes.

3.1.9 [2] RESTIT

To restore to normal pattern size.

3.1.10 [X] TEST

If [X] key is pressed, the system will run the program at top speed without executing M command. This feature is often used to position quickly or check the working size of steel plate. This operation can be paused at any moment or cancelled by pressing [X] key one more times.

3.1.11 [Y] AU-SPD

Since the manual speed and automatic speed is separate in the system, this key is used to switched between automatic mode and manual mode to adjust the speed multiplying factor.

3.2. Function selection in AUTO mode

It is allowed to invoke a machining program by means of **EDIT** feature. If a program has been invoked(as long as it is the same program name), it can be run directly. If the program is invoked from an USB disk, especially a large program, it can be run directly with USB disk connected instead of saving it into the system.

3.2.1[F1] SECTION

To assign system to start up machining operation from any section or piercing point.

It is often used when machining needs to start from a certain section or only a part needs being processed.

Refer to **SECTION** feature for details.

3.2.2[F2] MAN

To switch the system to manual mode.

3.2.3[F3] RESBREK

After this function is selected, pressing [**START**] key to fulfill breakpoint restoration. Refer to **RESBREK** feature for details.

3.2.4[F4] VIEW

It is used to test the program for any error. When this feature is selected, the pattern of machining program will be displayed with a cross cursor at the origin.

[S] key is used to magnify the pattern, one times by one keystroke and eight times maximum by three keystrokes. [Q] key is used to return the pattern to original size. The display position of pattern is moveable by pressing [↑], [↓], [←] and/or [→] key.

3.2.5[F5] KERF

This key is used to reminder input of kerf compensating width; if no necessary to compensate(usually in blanking), simply enter 0.

3.2.6[F6] ASSI

This key is used to enter the next lower level of menu, as shown in Fig. 3.2 below.



Fig. 3.2 ASSI window

3.2.7. [F3] ROTATE(steel plate correcting feature)

3.2.7.1Machining at rotation angle

This feature is used when the steel plate is not positioned perfectly or the steel plate needs to rotate an angle before machining. It is allowed to use **Rotate** function along with **BEG. PT.** and **END PT.** in **Manual** mode or input the expected angle directly. After acknowledged, the system will start the machining program at the appointed rotation angle.

Note: Counterclockwise direction is taken as positive angle.

3.2.7.2Example

The system is able to identify and calculate the rotation angle by measuring the origin point and the end point of an edge of steel plate(a straight line). The procedure is as follows:

- 1) Determine the datum line. Take one borderline of steel plate as baseline and move the cutting torch to the origin point of this baseline. Press [F2] to set the beginning point of measurement.
- 2) Control the cutting torch and let it move along the baseline to the end point. The larger distance between the beginning point and the end point, the more accurate of the measurement. Aim the cutting torch at the baseline and press [F3] to set the end point of measurement.
- 3) At this moment, the rotation angle of the datum line is calculated. After the rotate function is fulfilled, the rotation angle will appear in the OPERATE field, as shown in Fig. 3.2 below.

3.2.8[F4] MIRR

It is possible to select **X Mirror**, **Y Mirror** and **No Mirror** if press [F5] key continually. When X Mirror is selected, the machining program will run along the symmetry direction of X-axis, as appears inverted horizontally.

When Y Mirror is selected, the machining program will run along the symmetry direction of Y-axis, as appears

inverted vertically. When default No Mirror is selected, the machining program will run normally.

3.2.9 [F5] SCALE

The system will reminder user to input scale if this key is pressed. When the machining program is executed, the work size will magnify or minify as per this scale. This feature is very useful in cutting graphic character.

3.2.10 [F2] WENTAI

The system will prompt to run WENTAI-based machining program if this key is pressed. WENTAI is a word machining software for CAD/CAM, widely used in cutting graphic characters in advertisement business. This feature is required to run a WENTAI-based program.

3.3. Startup of speed mode(multiplying factor) and automatic mode

3.3.1 Manual speed and return speed

In either manual or return mode, manual multiplying factor is used to adjust speed.

Effective Speed = maximum speed limit * manual multiplying factor, where the manual multiplying factor is adjustable with [F], [F↑] and [F↓] key.

3.3.2 Machining Speed

Automatic multiplying factor is used to adjust machining speed.

Machining Speed = machining speed limit * machining multiplying factor, where the automatic multiplying factor is adjustable with [F], [F↑] and [F↓] key.

These two speed multiplying factors are permanently saved and subject to no affect from power-off operation once they are set.

3.3.3 Start of automatic mode

1) Prior to starting automatic mode,

Select correct machining program and appropriate machining speed(multiplying factor). Move the cutting torch to the cutting position. The cutting torch will be lifted automatically after a machining program is initiated(to execute M70). And now, it is ready to start the machining program in automatic mode.

2) Two starting methods in automatic mode:

- a) Press the green [START] key on the front panel.
- b) Press an external "START" key(See the definition of input/output ports).

3.4. Control and adjustment of cutting position in automatic mode

3.4.1 Only the following keys are enabled when the system starts automatic mode:

- 1)[PAUSE]: If this key is pressed, the system will slow down and stop movement, shut off cutting oxygen(shut off arcing switch in plasma machining case), turn off the height controller(M39) and remain the current display still. After the system operation is paused, it is allowed to perform the following operations:
 - (a) Return along the original path; (b)adjust position; (c)exit machining operation; (d) [START]: restore system operation; and
 - (e)Press [ESC] key to exit the machining program and return to automatic mode window.
- 2) [F↑] and [F↓] speed adjusting key: To increase or decrease the multiplying factor of feed speed.
- 3) [S ↑] and [S ↓] key: To control the vertical movement of cutting torch. By pushing and holding either key,

the cutting torch will move up or down accordingly, and the movement will stop if the key is released.

4)[Emergency Stop] key: It is an external key with signal received from the input port(refer to "External Input Ports" for details). If emergency stop is validated, all the movement will stop and no output will go on. It is used for emergency case.

3.4.2. Adjustment of cutting position

3.4.2.1 Situations necessary to adjust the position of cutting torch:

- 1) If the cutting torch is blocked or replacement is necessary, the usual practice is to move the cutting torch to somewhere safe and move it back to the starting point after the situation is resolved.
- 2) When it is required to pierce along the exterior margin and not position the piercing point at the exterior edge, the usual practice is to pinpoint an appropriate position in the exterior of workpiece for piercing and then cut the workpiece back to the starting point along a straight line before continue normal machining without stop.
- 3) In case of transitional cutting, too many workpiece or large size of workpiece, it might be necessary to relocate the cutting torch.

3.4.2.2 Situations allowed to adjust the cutting position:

(1) pause process, (2) return process, (3) piercing process, (4) section selection, (5) hole selection and (6) breakpoint restoration

If operator intends to change the position of cutting torch in the above-mentioned states, it is allowed to press [↑], [↓], [←] and/or [→] key to do so (in this case, it is manual multiplying factor, adjustable). When the expected position is reached, press [Start] key, as shown in the following dialog box:

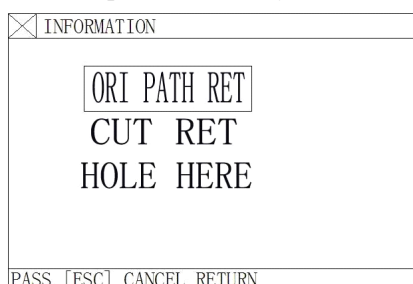

Fig. 3.3 Dialog box of position adjustment options

1) ORI PATH RET(original path return)

Return the cutting torch to the adjustment beginning point at speed G00 and wait for other operation; at this step, it is allowed to press an heavy-current function key such as IGN(ignition), PREHEA(piercing preheat), CUT(cutting oxygen), etc. **Tip: The system will continue to process from the breakpoint location if [PIERCE] key is pressed after preheating.**

2) CUT RET(cut return)

After piercing, the cutting torch returns from the current position to the adjustment beginning point along a straight line at cutting speed and continue machining along the original path without stop, which is somewhat like extended pierced, making the piercing point more smooth. ;

3) HOLE HERE(piercing here)

After piercing, set the coordinates at current point as coordinates of "adjustment beginning point", and continue machining along the original path to fulfill transitional piercing function.

4) Attention:

Be sure to have the system preheated sufficiently(for flame cutting) before taking steps 2) and 3) , for piercing

operation will start right away once the operation is selected.

It is recommended to preheat the system(for flame cutting) and then press [START] key to select appropriate operation.

3.5. Original Path Return

When it is necessary to return the cutting torch along the original path due to failure to cut through in machining operation, handle it in the following ways:

3.5.1 Return along original path

Press [PAUSE] key to suspend the running system. A "pause" mark will appear on the system display in addition to prompt as shown in the figure below.



Fig. 3.4 Machining pause display

Press [F6] key to return the cutting torch along the original path .

Press [F7] key to advance along the original path after returning. In the process of return, if the cutting torch fails to reach the required position, press [PAUSE] key again and repeat the above procedure until it reaches the right position .

3.5.2 Return at G00(when reach a piercing point)

In the process of return, the cutting torch will stop at G00 or a piercing point for operator to select going on return or advancing.

3.5.3 Operation after returned

After the cutting torch returns to the designated position, it is allowed to select position adjustment of cutting torch(refer to 3.4) or piercing directly by pressing the appropriate heavy-current function key such as PREHEA(piercing preheat) and CUT(cutting oxygen).

It is common practice to--

Press [PIERCE] key after preheating operation is done, or

For flame cutting operation, press CUT key(open the cutting oxygen) if the cutting torch lifts or continue machining if the cutting torch lowers; or

For plasma cutting operation, ignite arc and do not go on machining until the arc ignition is completed.

3.5.4 Repeat the above operation procedure until the desired effect is achieved.

3.5.5 To exit machining mode

In pause state, press [ESC] key to exit machining mode.

3.5.6 Total row number and beginning row in return process

The program segment for return allows 300 rows maximum. In case of breakpoint restoration(RESBREK) or machining section selection(SECTION), the return beginning row is the row containing the current breakpoint or the section selecting row, upon which however the cutting torch is not allowed to return along the original path for machining.

3.6. Breakpoint Restoration Process

3.6.1. Breakpoint restoration

- 1) In case of manual pause or power outage in machining operation, the system will automatically save the current position of cutting torch as a breakpoint, which will be kept permanently in the system, whether power the system off or not.
- 2) In automatic mode, press [F2] key to select RESBREK function and then [START] key to start breakpoint restoration as long as there is no change with the current program.
- 3) If the position of cutting torch does not change, the system will prompt "Breakpoint" when a breakpoint is found and wait for subsequent command. User may select piercing directly or position adjustment of cutting torch. Refer to 3.4 for details.
- 4) If the position of cutting torch does change and is off from the breakpoint, the system will provide three options when a program breakpoint is found, which is virtually **position adjustment of cutting torch**.

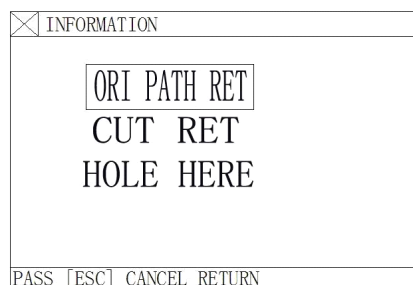

Fig.3.5 Dialog box of restart options after system pause and breakpoint restoration

ORI PATH RET: To return to the breakpoint at speed G00, which is often used for the breakpoint set for cutting torch replacement;

CUT RET: little bit off from the breakpoint after breakpoint restoration, which is somewhat like piercing along the exterior margin, making the breakpoint more smooth;

HOLE HERE: the same operation as previous, which can also be used for transitional cutting.

Now, it is allowed to press a heavy-current function key such as IGN(ignition), PREHEA(piercing preheat), CUT(cutting oxygen), etc.

Tip: The system will continue to process from the breakpoint location if [PIERCE] key is pressed after preheating.

If press [ESC] key when a breakpoint is found, the system will exit machining mode.

3.6.2 Attention:

Never try to change the machining program, rotation angle and scaling proportion whether it is breakpoint restoration or power-off restoration, which will be automatically saved by the system and free from affect by power-off operation; otherwise, the system can not find the breakpoint.

3.7. SECTION(section selection)

3.7.1. Start SECTION function

SECTION: to assign system to start up machining operation from any section or piercing point.

Press [F1] to select SECTION function and the system will show a menu as shown in the figure below:

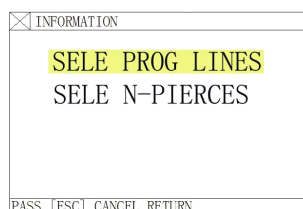

Fig. 3.5 SECTION function menu

Move the cursor with [↑] or [↓] key and make one choice from two machining options.

According to your option, the system will prompt to input the serial number of the option(program line number or the serial number of piercing point).

3.7.2. Two cases for SECTION machining option:

3.7.2.1 Transitional machining: to start machining somewhere different from the start position of the program;

3.7.2.2 Repeat the machining operation starting from a certain section of the program.

1) For the former case, a scrap work piece is often used for aiming at the piercing point and machining directly(**HERE POSITION** option);

2) For the latter case, the reference point is used for positioning(**REF POSITION** option).

3) For these two options, the system will prompt an option menu as shown below after startup:

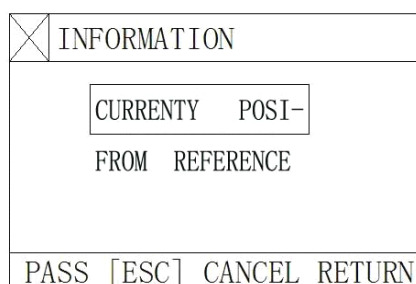

Fig. 3.6 Option dialog box prompted by the system after machining start if SECTION machining is selected

- If "**HERE POSITION**" option is selected, the system will draw the full pattern first and then draw a large cross cursor at the piercing point. Operator may press [S] key to zoom in the pattern and observe if it is the expected piercing position. If not satisfied, operator may press [ESC] to exit the machining mode and take the option again.
- If it is the expected piercing point, use heavy-current control switch for ignition and preheat before press [PIERCE] key to start operation.
- If "**REF POSITION**" option(Reference Point Positioning) is selected, operator should aim the cutting torch at the reference point. After started up, the system will control the cutting torch to reach the piercing point and then perform the operations as above.

3.8. MOVE HOLE for Thick Plate

- In automatic mode, **MOVE HOLE** option is taken for thick plate.
- For edge piercing method, it is important to **move the cutting torch to the nearest edge of steel plate before piercing operation.**
- Preheat the system and press [**START**] key at the end of preheat. The cutting torch will cut the steel plate along a straight line to the piercing point at selected cutting speed and then go on machining.
- When MOVE HOLE option is taken, it needs to change the **MOVE HOLE option** to 1 in the **parameter control** menu, thus to enables the option. In this way, whenever it is time for piercing operation, the system will prompt an option menu as shown below:

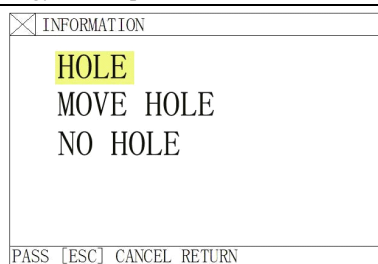

Fig. 3.7 Option dialog box prompted by the system after reach piercing point if edge piercing method is selected

3.8.1 HOLE

To pierce at the original position, which is often used for boring.

3.8.2 MOVE HOLE

- 1) Operator may press [↑], [↓], [←] and/or [→] key to move the cutting torch to the edge of steel plate; in the mean time, the speed multiplying factor is adjusted to 5% automatically. The system is preheated.
- 2) Press [START] key at the end of preheat. The cutting torch will reach the piercing point along a straight line at selected cutting speed and then go on machining.

3.8.3 NO HOLE

Instead of piercing, the system moves through the current piercing position to next, and new piercing prompt appears.

Chapter IV. MAN(Manual Mode)

In main menu, press [F2] to enter MAN (manual) window, as shown in figure below:

The screenshot shows the manual mode window for plasma cutting. The top status bar displays: SPEED: F*100%=0000, PROG: TK01.NC, PIERCE: 0000, KERF: 3.0 M. Below this, SPEED= 0 is shown. The main display area is divided into a large blue pattern display space on the left and a control panel on the right. The control panel includes function keys (X TEST, Y AU-SPL, 1 BLOWUP, 2 RESTIT, F ADSPED, G CONTIN) and input/output indicators (INPU: 00000000, OUTP: 00000000). Machining parameters are listed at the bottom right: ANGLE: 0.00, PROPORT: 1.0, BEG. ROW: 0.00, CUTLENGTH:, DISTANCE: 0.00, CRAWLTIME: 0.00. The bottom status bar shows coordinates (X 00003.022, Y 00071.104) and workmode (WORKMODE OPERATE.). A bottom menu bar contains keys: ESC, AUTO, MOVE, P-START, P-END, MDI, CLS CO, RETURN.

Callouts in the image identify the following elements:

- Active speed multiplying factor
- Program name
- Piercing No.
- Kerf
- Heavy-current control output
- Pattern Display Space
- Function keys
- Input/output indication
- Machining Parameters Indication
- Coordinates
- Workmode indicating zone
- Main menu of manual function

Manual mode window(plasma cutting operation)

The screenshot shows the manual mode window for flame cutting. The top status bar displays: SPEED: F*100%=0000, PROG: TK01.NC, PIERCE: 0000, KERF: 3.0 M. Below this, SPEED= 0 is shown. The main display area is divided into a large blue pattern display space on the left and a control panel on the right. The control panel includes function keys (X TEST, Y AU-SPL, 1 BLOWUP, 2 RESTIT, F ADSPED, G CONTIN) and input/output indicators (INPU: 00000000, OUTP: 00000000). Machining parameters are listed at the bottom right: ANGLE: 0.00, PROPORT: 1.0, BEG. ROW: 0.00, CUTLENGTH:, DISTANCE: 0.00, CRAWLTIME: 0.00. The bottom status bar shows coordinates (X 00003.022, Y 00071.104) and workmode (WORKMODE OPERATE.). The bottom menu bar contains keys: ESC, AUTO, MOVE, P-START, P-END, MDI, CLS CO, RETURN.

Manual mode window(flame cutting operation)

Fig.4.1 Manual mode window

4.1. Description of Manual Mode Window

The window display in manual mode is the same as it in automatic mode except that the multiplying factor is manually adjustable, which affects manual operation, return speed to reference point, move speed, etc.. There are some special operations in Model SH-2012AH-QG Cutting Machine (C002)

manual mode as follows:

4.1.1 [↑], [↓], [←], [→] directional control keys and [G] Continue Key

Generally, if any of the four direction keys is pressed and held, appropriate axial movement will carry on until the key is released. However, if [G] Continue key is pressed and highlighted before any direction key is pressed, the cutting torch will keep moving even if the key is released. The movement will not stop until the direction key is pressed again. If two axial movements are required, let one axial movement start first and then press the direction key for the other axial movement. Two axial movement will go on simultaneously. In this case, the axial movement of cutting torch will stop if the corresponding direction key is pressed while the other axial movement will go on until the corresponding direction key is pressed too. [PAUSE] key will stop the movement as well.

4.1.2 【F1】 AUTO

The system is switched to automatic mode.

4.1.3 【F2】 MOVE

If MOVE function(highlighted) is selected, the system will prompt to input MOVE INCREMENT: 0050.000 (previous input value by default). In MOVE mode, if direction key is pressed once, the cutting torch will move an increment at the speed of the current maximum speed limit multiplied by multiplying factor.

4.1.4 【F2】P-START, 【F3】P-END and Calibration function

This feature is used when the steel plate is not positioned perfectly or the steel plate needs to rotate an angle before machining. Let the cutting torch go along a straight edge as long as possible. Pick up two points([F2] for setting P-START and [F3] for P-END). The system will calculate automatically the rotation angle. Select the ROTATE function in automatic mode. After acknowledged, the system will start the machining program at the appointed rotation angle.

Note: Counterclockwise direction is taken as positive angle.

4.1.5 【F6】 CLS-CO

Input X/Y coordinates with any value.

4.1.6 【F5】 M D I

4.1.7 Speed

At the top left corner of the screen, it shows $F \times (\text{speed multiplying factor in manual mode}) = \text{manual speed}$.

It is allowed to adjust the speed quickly by pressing [F] key in this window. A pull-down menu will appear with 8 speed multiplying factors available for selection with [↑] and/or [↓] key: 5%, 20%, 30%, 40%, 50%, 60%, 80% and 100%. And then, press RETURN key to acknowledge the selection.

Chapter V. EDIT Mode

In the system main menu, press [F3] to enter EDIT menu as shown in the figure below:

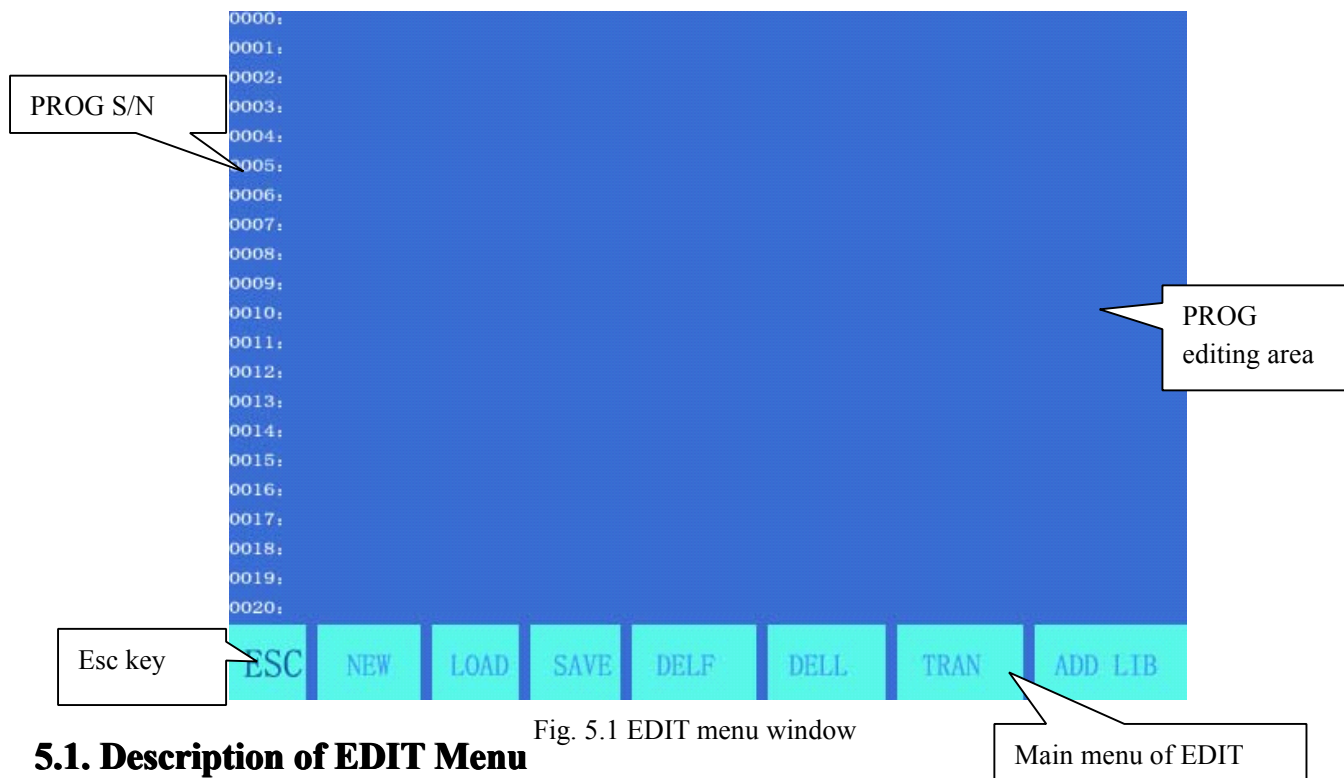

Fig. 5.1 EDIT menu window

5.1. Description of EDIT Menu

5.1.1 【F1】 NEW

To establish a new program, i.e., clear the editing area of machining program and start to edit a new machining program.

5.1.2 【F2】 LOAD

To load a program. Specifically, it is used to load a program into the user program area. The system will tabularize the available program names and highlight the current program name. Move the cursor key to select different programs. If ENTER key is pressed, the highlighted program will be loaded into program editing area; if [ESC] key is pressed, the load function will be abandoned.

5.1.3 【F3】 SAVE

To save program. After a program is edited and ready to save, the system will prompt:

Enter program name: 1234.TXT

The system will display the current program name, which is modifiable. If ENTER key is pressed, the program in the editing area will be saved into the program area under the selected name; if [ESC] key is pressed, the save function will be abandoned.

Notes:

- 1) The program name and extension name should never exceed 12 characters.
- 2) For large-sized program above 200K, it is allowed to work along with USB disk instead of saving it.

5.1.4. 【F4】 DELE

It is used to delete the program in the user program area.

5.1.5. 【F5】 DELL

To delete a full program line in editing area and improve editing efficiency.

5.1.6. 【F6】 TRAN

To transmit programs. This system supports to transmit programs with USB disk. Press [F6] key to enter the lower level of menu, as shown below. :

ESC	INPUT F1	OUTPUT F2
-----	-------------	--------------

Fig. 5.2 Transmission menu of USB disk

[F1] Input: to transmit program from USB disk to the machining program space.

[F2] output: to output the machining program to USB disk from the machining program space.

5.1.7. 【F7】 SEARCH STRING

This feature is not provided yet. It is reserved for subsequent upgrading.

Chapter VI. Command System

6.1. Description of Programing Symbols

In CNC cutting operation, each step is taken according to a program. Each machining program is composed of several command segments, each command segment is composed of several function words and each function word is required to be a letter followed by parameter value.

Definitions of Function Words:

N	Serial number of command segment
G	Preparatory function
M	Auxiliary function
T	Tool function(refer to as flame width in this system)
L	Number of cycles, time delay
X	X-axis(diameter) absolute coordinate
Y	Y-axis absolute coordinate
I	The difference between the coordinate value of circle center and X-axis original value in arc cutting operation
J	The difference between the coordinate value of circle center and Y-axis original value in arc cutting operation
R	To designate arc radius
H	To designate arc chordal height
A	Auxiliary variable
F	To designate machining speed for G01, G02 and G03

Note 1: The following rules are valid in the definitions below:

X[U]n--- It is allowed to be either X or U and n stand for a value; 同理,

Y[V]n----It is allowed to be either Y or V, and n stand for a value;

PPn----It is allowed to be a combination of any two axes or one axis at least.

Note 2: In command execution, the previous program has higher priority than the following one; for the same program, M, S and T command have higher priority than G command.

6.2. Coordinate System

This CNC system uses standard rectangular coordinate system, as shown in the figure below.

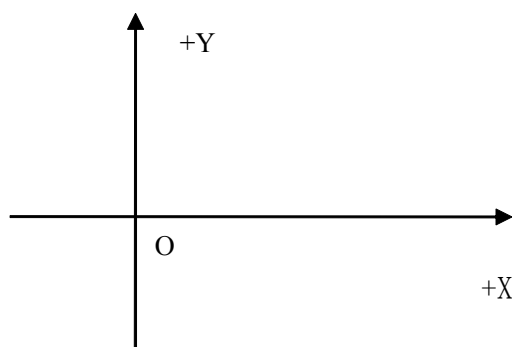

Fig. 6.1 Rectangular coordinate system

6.3. G: Basic Preparatory Commands

1) G92: Reference Point Setting Command

When developing a program, it is required to place the coordinate value(absolute coordinate) of machining origin point(reference point) at the very beginning.

Format: G92 Xn Yn

If G92 is not followed with X/Y coordinate values, then the current X/Y coordinate will be taken as reference point. Generally, when the origin point of machine is used as **reference point** for positioning purpose, G92 will not be followed with X/Z values.

2) G90/G91: Absolute/Relative Coordinate Commands

When using G90, X/Y represent coordinate values and U/V represent the values relative to the current point; when using G91, X/Y and U/V all represent the values relative to the current point.

Format: G90

Format: G91

Example 1: G92 X0 Y0

```
G91 // Relative coordinate system
G00 X100 Y100 // Quickly reach point(100, 100), equivalent to G00/U100/V100
G01 X500 Y100 // Machining to point(600,200) along a straight line, equivalent
```

G01/U500/V100

Example 2: G92 X0 Y0

```
G90 // Absolute coordinate system, by default
G00 X100 Y100 // Quickly reach point(100, 100)
G01 X600 Y200 // Machining to point(600,200) along a straight line
```

3) G20/G21: English/Metric Commands

G20 stands for English system. Following G20, the values of X, Y, I, J, R, U, V, H and F are all in English unit;

G21 stands for metric system. Following G21, the values of X, Y, I, J, R, U, V, H and F are all in metric unit;

Format: G20

Format: G21

E. g. : G92 X0 Y0

G00 X120 Y280

(or G00 U120 V280)

M02
Current Torch Position

○ Expected Torch Position

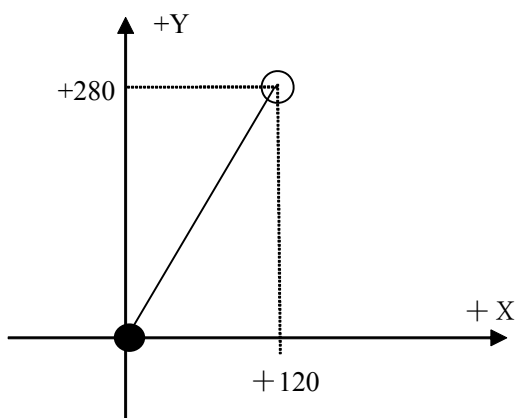

4) G00 Quick Move

This command can move the cutting torch quickly to a designated position. In the event of two axial movements, the cutting torch will move along a straight line from the origin point to the end point **at the speed of the maximum speed limit multiplied by multiplying factor**. G00 movement is subject to speed multiplying factor.

Format: G00 X[U]n Y[V]n

or G00 PPn

5) G01: Linear Cutting Command

This command makes the torch cut to a designated position along a straight line. As machining movement command, it allows uniaxial or biaxial linear interpolation movement. The feed speed is designated by F command.

Format: G01 X[U]n Z[W]n [Fn]

or G01 PPn [Fn]

例: G92 X0 Y0

G00 X200 Y95

G01 X80 Y235

Current Torch Position

○ Expected Torch Position

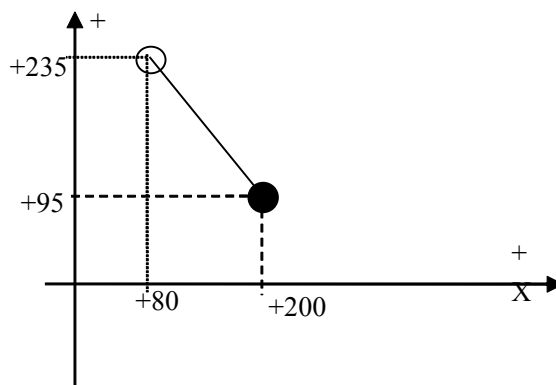

6) G02/G03: Circular Cutting Commands

This command is used for circular interpolation, including clockwise circular cutting command G02 and counterclockwise circular cutting command G03. See the figure below for the setting of directions.

Format: G02[03] X[U]n Y[V]n In Jn [Fn] or G02[03] X[U]n Y[V]n Rn [Fn]

G02[03]PPn In Kn [Fn] or G02[03] PPn Rn [Fn]

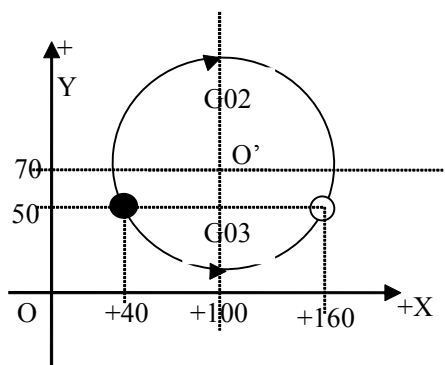

● Current Torch Position
○ Expected Torch Position

例 (G02) :

```
G92 X0 Y0
G00 X40 Y50
G02 X160 V0 I60 J20
G28
M02
```

例 (G03) :

```
G92 X0 Y0
```

Notes:

- I and J are the increased values of circle center relative to the origin point in X-axis and Y-axis respectively (distance between the circle center and the origin point).
- R is the radius of circle (R is a positive value and can be used to represent radius where circular arc $\leq 180^\circ$).
- Alternatively, if I and J are designated, R will be not necessary; if R is designated, I and J will be not necessary.

7) G04: Pause/Delay Command

This command is used for settling time delay. When this command is executed in a program, the time delay defined by command L in seconds will be given.

Format: G04 Ln

Example: G04 L2.4 (To delay 2.4 seconds)

In the execution process of G04 command, if [START] key is pressed, the time delay will be disabled and the subsequent program will be executed continually. If [Exit] key is pressed, the execution of the current program will be aborted.

8) G26/G27/G28: Return Reference Point Commands

Thess commands make the cutting torch return to the reference point automatically.

Format: G26

Return to the reference point along X axis.

G27

Return to the reference point along Y axis.

G28

Return to the reference point simultaneously along both X and Y axes.

Example: G28(simultaneously return to reference point, equivalent to execute G00 command)

G22/G80: Repetitive Commands

These commands are used for execution of program loop. G22 is used to designate the start of loop and number of cycles L. G80 is the end mark of loop. These commands may be used for nested loop not more than

5 levels. G22 and the nearest G80 form a loop.

Format: **G22 Ln_** **(L to designate number of cycles)**

Loop

G80 **(End mark of loop)**

Example: N000 G92 X100 Y100

N001 G00 X60 Y80

N002 G22 L5 - Level 1 loop starts.

N003 G00 V50 U-25

N004 G22 L5 - Level 2 loop starts.

N005 G01 U5 V-10

N006 G80 - Level 2 loop ends.

N007 G80 - Level 1 loop ends.

N008 G28

N009 M02

10) G40/G41/G42: Cutter Radius Compensation Commands

Format: G41 (or G42) Rn

.

.

Program segment to be compensated.

.

.

G40

Notes:

G41 is to compensate a half diameter of flame **leftwards** along the machining path.

G42 is to compensate a half diameter of flame **rightwards** along the machining path.

G40 represents end of offset.

Since cutter compensation is made automatically, there must be G00 Quick Move command before G41 or G42 commands so as to assure the position of cutting torch is corrected. Behind G40 the end mark of cutter compensation, a G00 command is necessary to adjust the position back.

6.4. M Auxiliary Commands

M00 **Program suspension** command. The program execution will be suspended at this command until [START] key is pressed.

M02 **Program end** command. The program will be pended at this command.

M30 The same as M02.

M10/M11 **Acetylene(GAS)** valve switch commands, M10 to open and M11 to close the valve.

M12/M13 **Cutting oxygen valve** switch commands, M12 to open and M13 to close the valve.

M14/M15 **Cutting torch lift** switch commands, M14 to turn on and M15 to turn off.

M16/M17 **Cutting torch lower** switch commands, M16 to turn on and M17 to turn off.

M24/M25 Reserved switch commands, M24 to turn on and M25 to turn off.

M20/M21 Ignition switch commands, M20 to turn on and M21 to turn off.

M07 **Fixed loop of piercing(M07 allows to relocate the cutting torch, but impossible to return)**

M08 **Fixed loop of cutting stop**

The operation sequence of M07 in flame cutting operation is as follows:

1. Open acetylene(gas) valve and ignite the torch if the valve is not open.
2. Lower the cutting torch(for time delay of torch lowering, see M71 command);
3. Open the oxygen preheating valve and count preheating time delay. If the preheating time is insufficient, it will be prolonged to 150 seconds automatically by pressing [PAUSE] key. If preheating is done in the midway, press [START] key to abort the time delay. The new preheating time will be automatically saved in the parameter of preheating time delay.
4. Lift the cutting torch(and count the time delay of lifting torch, M72);
5. Open the cutting oxygen valve(M12), count the time delay and lower the cutting torch(count the time delay of lowering torch , M73).
6. Switch on height controller(M38) and run the subsequent program.

The operation sequence of M07 in plasma cutting operation is as follows:

1. Lower the cutting torch(and count the time delay of lowering torch, see M71);
2. If hole positioning option is enabled(refer to SETUP), the cutting torch will move down until hit the lower limit switch. Then the cutting torch will move up until the hole positioning time delay is up.
3. Turn on the arc ignition switch.
4. Test the signal of "Arc Voltage Successful", which will not be tested if the arc voltage test option is taken to 0(not test). When arc ignition is successful, the piercing time delay will start to count in seconds.
5. Switch on height controller(M38) and run the subsequent program.

M08: fixed loop of cutting stop

The operation sequence of M08 in flame cutting operation is as follows:

1. Close the cutting oxygen valve(M13).
2. Turn off the height controller(M39).
3. Lift the cutting torch(M70).

The operation sequence of M08 in plasma cutting operation is as follows:

1. Turn off the arc voltage switch.
2. Turn off the height controller(M39).
3. Lift the cutting torch(M70).

M50: Piercing action

1. Lift the cutting torch(M72). There is no this step in plasma cutting operation.
2. Open the cutting oxygen valve(M12) or turn on plasma arc ignition and check for the signal of "Arc Voltage Successful".
3. Lower the cutting torch(M73). There is no this step in plasma cutting operation.
4. Switch on height controller(M38).

M52: Fixed loop of ignition

Operation sequence: open acetylene(gas) valve(M10); turn on the high voltage ignition(M20); count the ignition time delay and turn off the high voltage ignition(M21).

M70: Fixed loop of lifting torch

Used at the beginning of a program and at the end of cutting section, this command is to raise the cutting torch for possibility to move quickly to next cutting position. The operation sequence is as follows: turn on the torch lifting switch(M14); count the time delay of lifting torch(refer to 7.3 for flame parameter); turn off the torch lifting switch(M15).

M71: Fixed loop of lowering torch

This command is used before piercing operation, opposite to M70 in function and little bit smaller in value. Because of gravity, the lowering action is faster than lifting action. Operation sequence: turn on the torch lowering switch(M16), count the time delay of lowering torch(refer to 7.3 for flame parameter) and turn off the torch lowering switch(M17).

M72: Loop of lifting the piercing torch

At the end of preheating, this command is used to lift the cutting torch somewhat to prevent the torch nozzle from blocked by splashing slag. The operation sequence is as follows: turn on the torch lifting switch(M14); count the time delay of lifting the piercing torch(refer to 7.3 for flame parameter); turn off the torch lifting switch(M15).

M73: Loop of lowering the piercing torch

At the end of preheating after M72 is executed and the cutting oxygen valve is opened, this command is used to move the torch to the cutting position, opposite to M72 in function and little bit smaller in value. Because of gravity, the lowering action is faster than lifting action. Operation sequence: turn on the torch lowering switch(M16), count the time delay of lowering the piercing torch(refer to 7.3 for flame parameter) and turn off the torch lowering switch(M17).

M75: Time delay of torch positioning

When positioning the plasma gun, lower the torch(M16). It will not stop until the torch hits the lower limit switch (refer to input port 8 XXW)(M17). Turn on the torch lifting switch(M14). After count the time delay of torch positioning(refer to 7.4 for plasma parameter), the lifting torch will stop(M15).

M80: Master switch

All the output ports will be turned off if the command of M80 is executed.

Chapter VII. SETUP(Parameter Setting)

In the system main menu, press [F4] to enter parameter setting window as shown below:

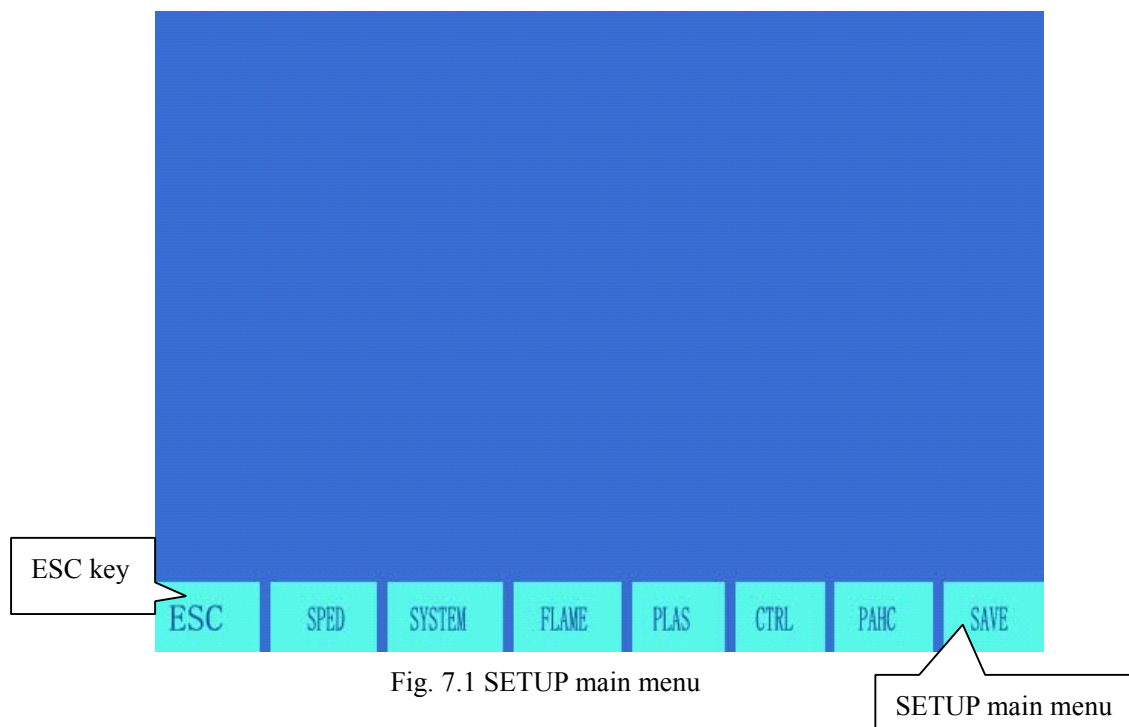

Fig. 7.1 SETUP main menu

7.1. Parameter Description

Speed parameters

Starting speeds of every axis, adjustment time and maximum speed limit.

System parameters

Gear ratio, mechanical origin, reference point, reverse backlash, line bias and soft positive/negative limit switch in every axis

Flame cutting parameters

Ignition delay, preheating delay, torch lifting/lowering delay, lifting/lowering of piercing torch, piercing delay, etc.

Plasma parameters

Torch positioning delay, M commands for arc ignition, M commands for arc breaking, arc voltage test option, positioning test option and piercing delay.

Control parameters

Flame/plasma mode selection, machining speed limit, MOVE HOLE option, metric/English selection, etc.

Height controller

Arc voltage raising option, fine tuning of control speed, sensitivity of height controller, arc voltage height control, etc.

Save

Save the modified parameters into parameters space.

Continuous pressing S key, optional external manual control key and manual enable/disable option.

Notes:

- 1) When selecting the above parameters, it is required to save the change separately by pressing [F8] key for validation.
- 2) If the password of "1928" is entered in the main window of SETUP, the saving menu of [F8] will turn to factory setting. In this mode, every modification to parameter will be saved into the factory setting parameters and the active user parameters. When initializing parameters, it is suggested to set the factory parameters as active parameters; otherwise, the modifications will be validated to the active user parameters.

7.2. SETUP(parameter setting)**7.2.1. Speed parameters**

In the SETUP submenu, press [F1] key to enter speed parameters setting window, as shown in Fig. 7.2.

Speed parameters include--

Starting speed----The starting and stop speed of system in X axis and Y axis in mm/min or inch/min. Refer to Control Parameters for more.

Adjustment time----The time required for the system to accelerate from starting speed to maximum speed limit, in seconds.

Uniform acceleration time---- In the process of acceleration/deceleration, the time needed for linear acceleration, which is usually little bit smaller than the adjustment time by one tenth approximately.

Maximum speed limit----The top speed of running system in manual control mode and in execution of G00 command, in mm/min. or inch/min.

Machining speed limit----The top machining speed in flame/plasma machining operation, in mm/min. or inch/min.

Conversion angle of corner speed ----- When the running direction changes between program segments and changing angle exceeds this angle, the system will decelerate to the starting speed around the corner. This value is normally set smaller when the system is comparatively heavier. In addition, such considerations as machining speed and machine vibration should be taken as well, smaller value for worse vibration.

Circular corner transitional option ---- If this option is enabled(value:1), the system will not decelerate through a circular transition when the running direction change of system between program segments is within the conversion angle of corner speed, as shown in the figure below.

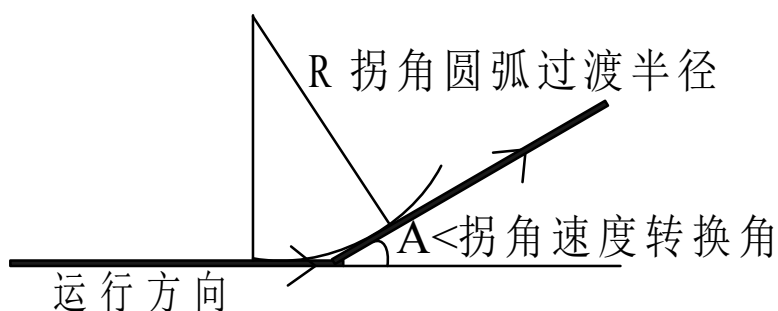

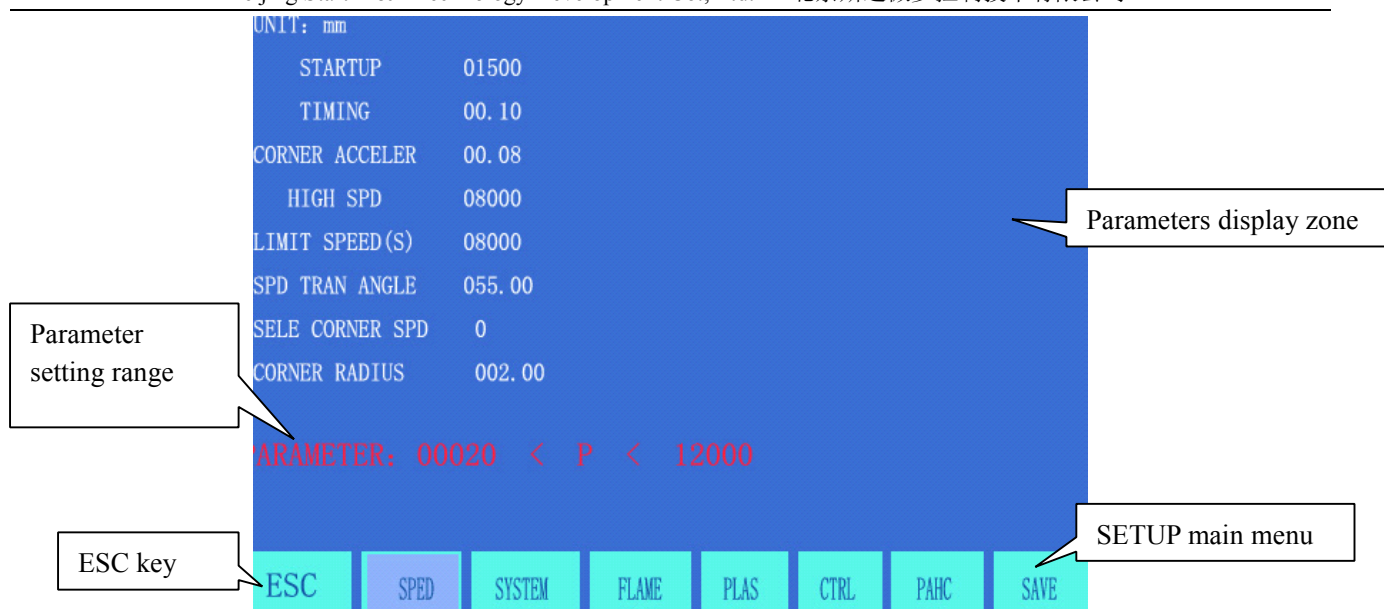

Fig. 7.2 Speed parameters setting

8) **Circular corner transitional radius** --- Refer to circular corner transitional option.

7.2.2. System parameters

In the SETUP submenu, press [F2] key to enter system parameters setting window, as shown in Fig. 7.3.

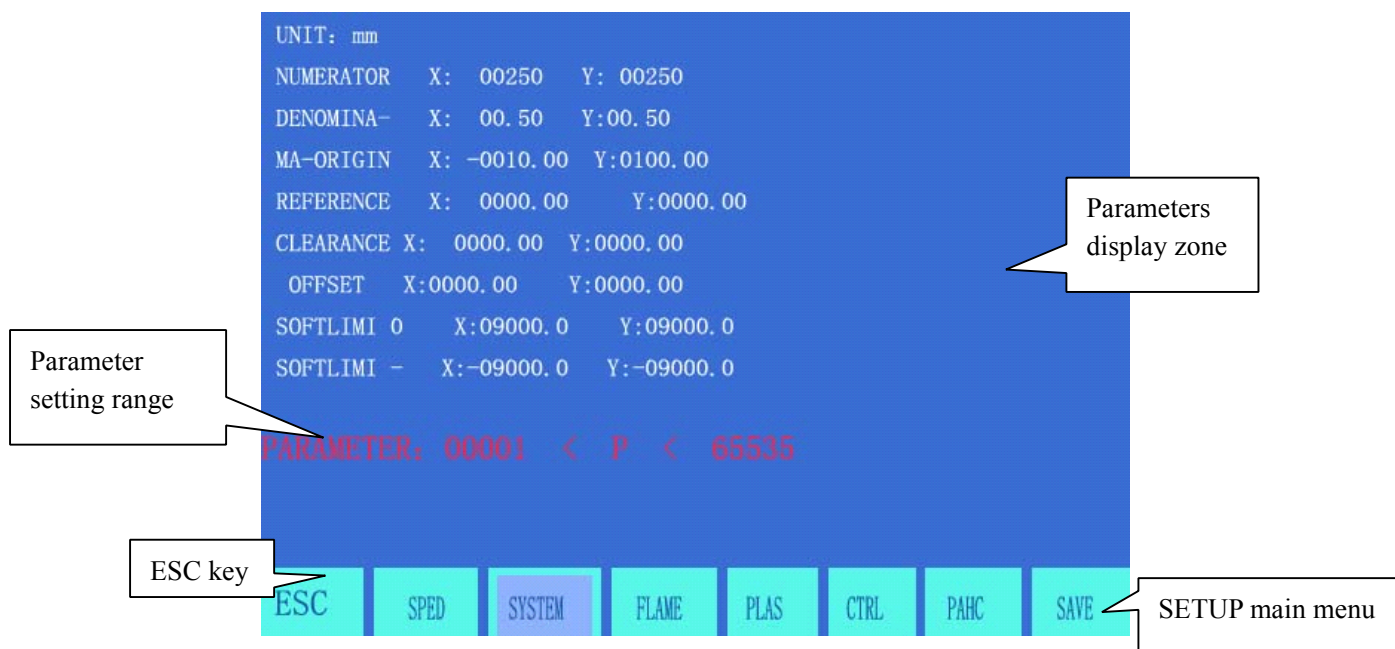

Fig. 7.3 System parameters setting

Numerator/denominator ratio of electronic gear---The numerator/denominator ratio of electronic gear is pulse equivalency in micron.

Numerator < 65535, denominator < 65535.

Example: if the pulse equivalency of system is 0.008mm, its numerator/denominator ratio of electronic gear = 8/1.

Electronic Gear Ratio = Pitch of Screw Rod × 1000(360 × Subdivision Number / Stepping Angle × Drive Ratio)

The computation method(adjustment method) of electronic gear is as follows:

- (1) Firstly, assume an electronic gear ratio, e.g., 8:1.
- (2) Control the machine to move a reference distance(the longer, the more accurate). Measure the actual travel distance and take

the measured value into the following formula:

$$\frac{\text{Numerator X Actual Travel Distance}}{\text{Denominator X Theoretical Travel Distance}}$$

Simplify the above formula to a fraction in lowest terms.

E.g., assume the electronic gear ratio is 8:1 and the theoretical travel distance is 2000mm and the actual travel distance is 2651 mm.

$$\frac{8 \times 2651}{1 \times 2000} = \frac{2651}{250}$$

Mechanical origin — A special point on the machine set with proximity switch. If mechanical origin is not to be used, set it to zero. Unit: mm(or inch)

Reference point — It is defined as the machining origin of program and established automatically when a program is run(G92). Unit: mm(or inch).

Reverse backlash—Due to reverse mechanical backlash, the system will compensate the backlash at direction change. The backlash value is obtained by actual measurement in mm or inch. **Generally, reverse backlash is not recommended.**

Line bias—Axial bias between scriber and cutting torch in mm or inch.

Soft positive/negative limit switch—The system will give an alarm when program coordinate exceeds the set soft positive/negative limit. If it will not be used, the parameter should be set higher than actual values in mm or inch.

7.3. Flame Cutting Parameters

In the SETUP submenu, press [F3] key to enter flame parameters setting window, as shown in Fig. 7.4.

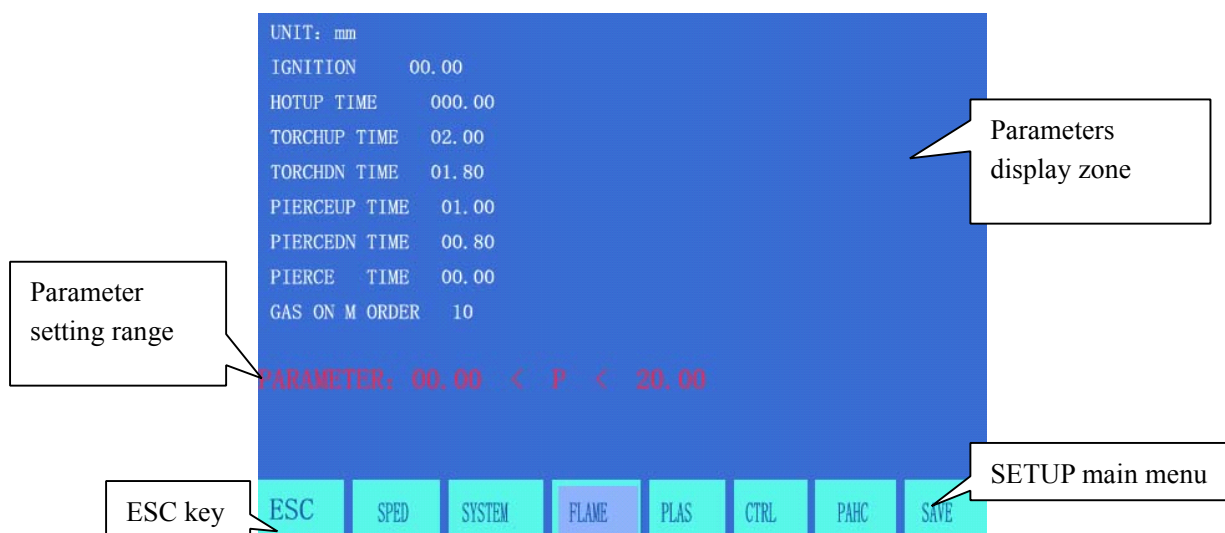

Fig. 7.4 Flame parameters setting

Ignition delay—It is the time delay when turn on the high voltage ignition switch if M20 is executed in flame cutting operation.

Preheating delay—It is the preheating time for piercing operation in second. If the preheating time is insufficient, it will be prolonged to 150 seconds automatically by pressing [PAUSE] key. If preheating is done in the midway, press [START] key to abort the time delay. The new preheating time will be automatically saved in the parameter of preheating delay.

Lifting delay of cutting torch—The time delay when M70 command is executed in second. Refer to 6.4 for M auxiliary commands.

Lowering delay of cutting torch—The time delay when M71 command is executed, in second. Refer to 6.4 for M

auxiliary commands.

Lifting delay of piercing torch——The time delay when M72 command is executed, in second. Refer to 6.4 for M auxiliary commands.

Lowering delay of piercing torch——The time delay when M73 command is executed, in second. Refer to 6.4 for M auxiliary commands.

Piercing delay——Lowering delay of cutting torch when M07 is executed in flame piercing operation after cutting oxygen valve is opened.

7.4. Plasma Parameters Setting

In the SETUP submenu, press [F4] key to enter plasma parameters setting window, as shown in Fig. 7.5.

Positioning delay of cutting torch——When positioning the plasma torch, lower the torch until it hits the lower limit switch. Turn on the torch lifting switch. After count the positioning delay of cutting torch, the lifting torch will stop(M75), in second.

M commands for arc ignition——To set the output port of arc ignition, M12 by default

M commands for arc breaking——To set the output port of arc breaking, M13 by default

Notes:

When the M command for arc breaking is next higher than the M command for arc ignition, it implies they share an output port, even number for opening and even number for closing. In this case, the system uses level control to direct arc ignition switch. When the M command for arc breaking and the M command for arc ignition are both even number but unequal to each other, it implies there are two output ports separately control the opening and closing operations. In this case, the system uses pulse control with pulse width of 0.5 second.

Arc voltage test option——It is used to determine if arc voltage is tested or not in plasma cutting operation. To enable arc voltage test, take 1 for the option. User should test arc voltage feedback at arc ignition and monitor the feedback in operation. When arc voltage feedback is off, the system will pause the operation and prompt. As a general rule, arc voltage test is enabled for thick plate machining. To disable arc voltage test, take 0 for the option. After the arc ignition switch is turned on, the machining will start when the piercing delay is up. The system will not test arc voltage feedback in the cutting process. Generally, arc voltage test is disabled for thin sheet machining.

Positioning test option——In execution of M07 command, it is used to determine torch positioning operation or not. If the option is taken 1, torch positioning operation will be enabled.

Piercing delay——If arc ignition is successful, the system will start normal cutting operation after the piercing delay.

Height control disabling distance at corner ----- At the transition or corner of two program segments, speed and arc voltage might change, causing unexpected nozzle knock; therefore, the system will automatically disable the height control in such a distance from the endpoint of program segment, in mm.

Arc voltage disabling distance near end point ----- The machining path is usually a closed curve. At the end of machining, the origin point and the end point will repeat, which often cause overburn and affect the smoothness. If this distance option is enabled, the system will automatically disable the arc voltage and the height control in such a distance from the endpoint, in mm.

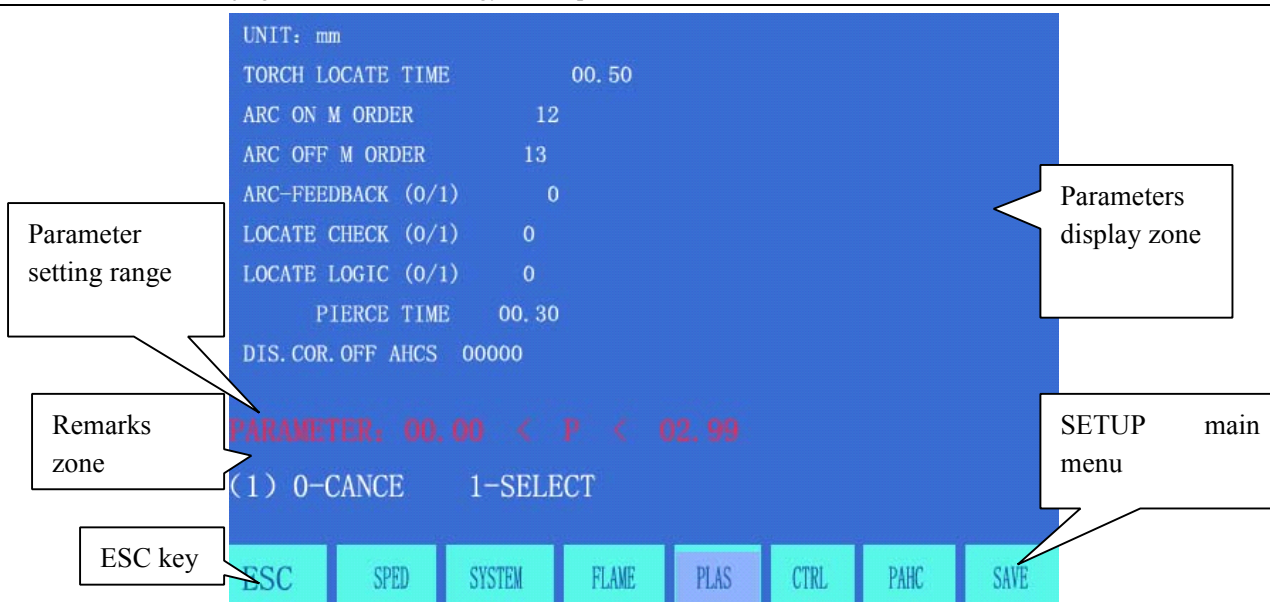

Fig.7.5 Plasma Parameters Setting

7.5. Control Parameters Setting

In the SETUP submenu, press [F5] key to enter control parameters setting window, as shown in Fig. 7.6

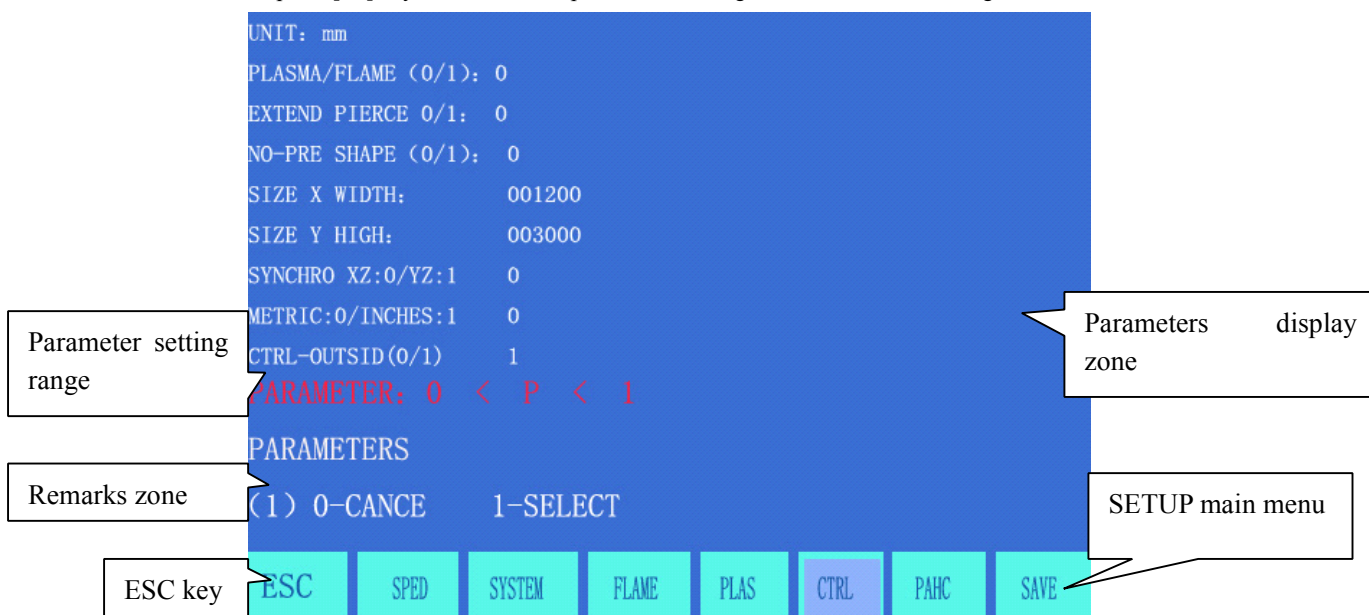

Fig. 7.6 Control parameters menu

Flame/plasma option——Take 0 for flame machining and 1 for plasma machining.

Move hole option——0 stands for disabling the option and 1 for enabling the option.

No-pretreatment pattern—— The normal machining procedure is to machining program first to calculate the maximum value and the minimum value of the pattern. However, it might take too long to handle a large program. Therefore, it is allowed to set the maximum value and the minimum value of pattern in advance without pattern pretreatment(see the parameters below). The system will machine the workpiece when drawing the pattern.

X-axis width of steel plate —— The actual width of steel plate along X axis, which is enabled only in running extra large program.

Y-axis height of steel plate —— The actual height of steel plate along Y axis, which is enabled only in running extra large program.

Common edge option——Since the system may control three kinematic axes, this option is used to determine the 3rd axis(Z

axis) shares a common edge with X axis or with Y axis for the machine requiring double-edge drive. Take 0 to have Z axis and X axis share a common edge; take 1 to have Z axis and Y axis share a common edge.

Metric/English system option ——Take 0 for metric system, which will have length parameters, speed parameters and values as well as coordinates expressed in metric unit(mm), though it supports machining program in English system(G20). Take 1 for English system, which will have parameters, display and coordinates expressed in English unit (inch), though it supports machining program in metric program(G21).

Attention: Please be cautious to make any change if no idea of the specific application of a parameter!

7.6 . Control Parameters Setting of Height Controller

In the SETUP submenu, press [F6] key to enter the control parameters setting window of height controller. This control feature is available only when plasma arc voltage control is used along with the height controller manufactured by Microstep, as shown in Fig. 7.7.



Fig. 7.7 Height control function

Arc voltage/height control option ——This option is editable only when plasma arc voltage control is used along with the height controller manufactured by Microstep. Take 1 to enable this option.

Fine tuning of control speed ——The default value is 100. If the control response is found too slow, reduce the value appropriately; otherwise, increase this value.

Height controller sensitivity(0-40) ——This value is used to adjust the sensitivity of height controller in the range of 0 to 40. If vertical vibration is detected, it implies the sensitivity is too high and reducing this value is recommended; if it is found slow in response, it implies the sensitivity is too low and increasing this value is recommended.

Arc-voltage height control(30-255V)——It is equivalent to the height knob of height controller. Larger value will make the cutting torch higher; vice versa.

Speed regulation range D ——It is often set to 100.

Positioning height B —— The height to raise the cutting torch when the torch hits steel plate in the process of initial location.

Upper/lower limit value ——To adjust the upper and lower limits of height controller

Chapter VIII. LIBMINIT(Library of Patterns)

8.1. LIBMINIT Setting

In addition to customized pattern module, the feature allows user to input the intended dimensions and get the expected workpiece.

When entering parameter, the control system will conduct general check to the physical dimensions and prompt warning message if any error is detected.

Notes:

- 1) It is impossible for the control system to find all the error parameters; therefore, please enter correct dimensions for parameters as much as possible.
- 2) When the parameters are entered, the control system will draw the pattern based on the entered parameters, which is very helpful to graphic check.

In the system main menu, press [F6] to enter the LIBMINIT(Library of Patterns).

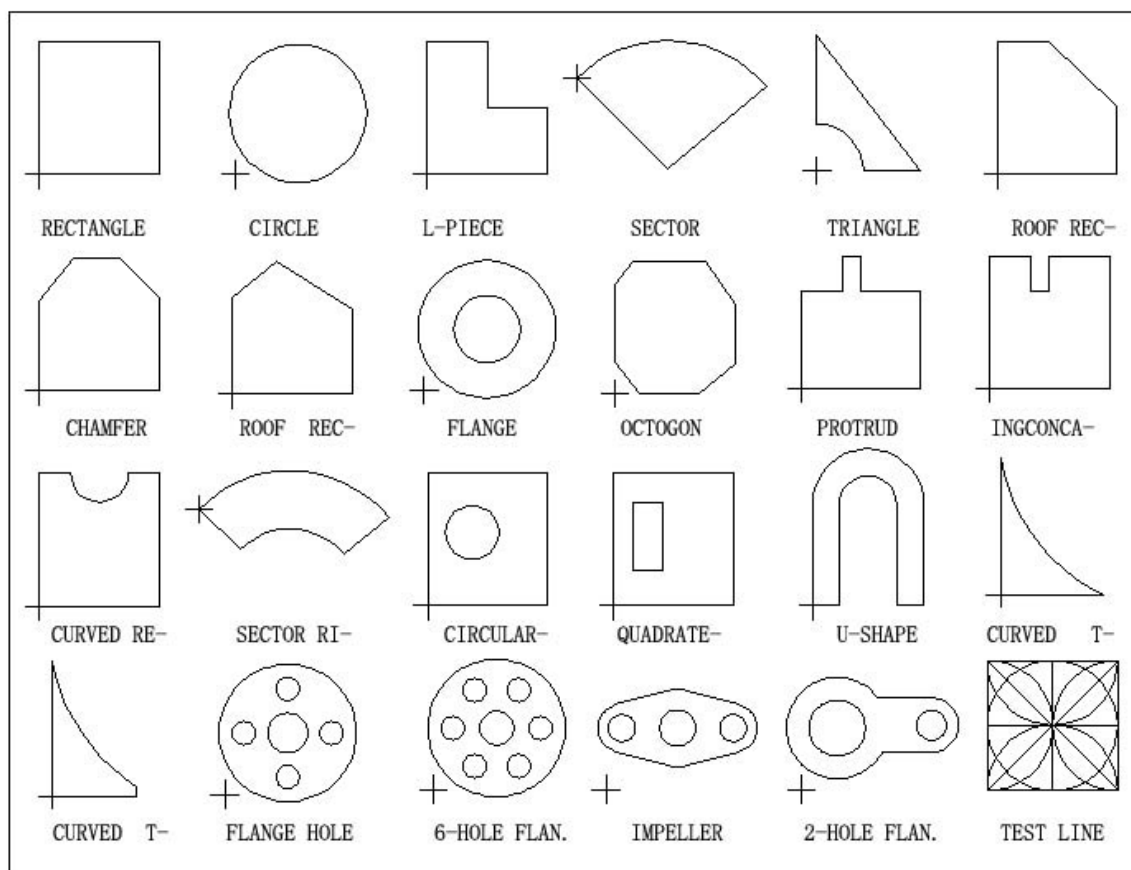

Fig. 8.1 LIBMINIT Feature(Library of Patterns)

8.2. Selection of Pattern Elements

So far, this system provides 24 pattern elements, which is expandable at any time as per client requirement. It is allowed to select the interested pattern by pressing [↑], [↓], [←] and/or [→] key to move the cursor to right position and press [ENTER] to acknowledge the selection.

Note: The 17th pattern element is customized element.

8.3. Arrangement and Layout of Pattern Element

After pattern element is selected as per the above-mentioned procedure, the system will prompt at the upper right corner to input parameters for the pattern, as show in Fig. 8.2

【F1】 Workpiece: To machine into workpiece that is solid internally.

【F2】 Hole: To machine into hole that is solid externally.

【F3】 Rotate: The system will prompt to input rotation angle and press [ENTER] or [F6] to acknowledge. The pattern rotated such an angle will appear. Counterclockwise direction is taken as positive angle.

【F4】 Layout: The system will prompt user to provide:

Row number----Row number of machined parts array

Column number----Column number of machined parts array

Row pitch----Distance between rows.

Column pitch----Horizontal distance between machined parts

Row offset----The deviation of raw misplacement, as shown in Fig. 8.3.

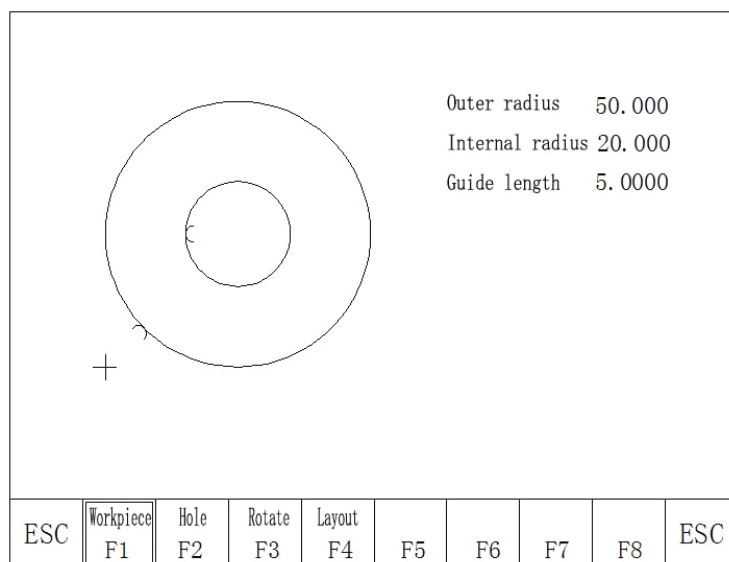

Fig. 8.2 Pattern setting menu

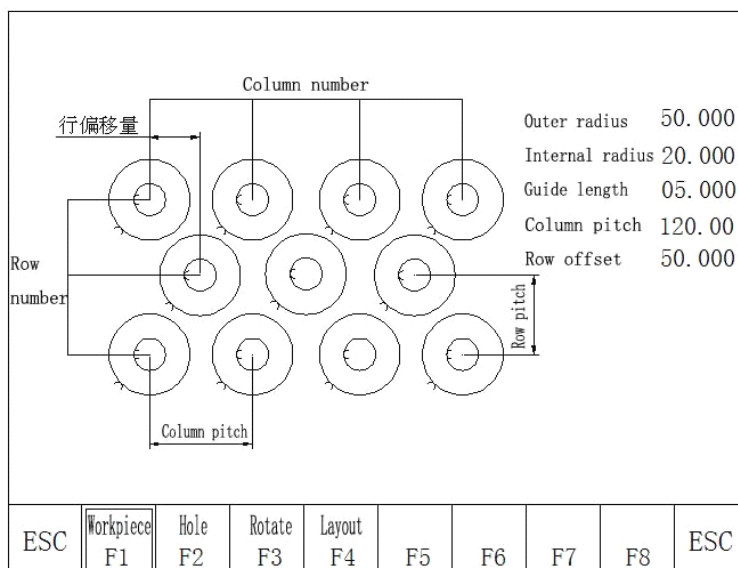

Fig. 8.3 Schematic diagram of part layout

【F8】 Submit: After parameters are set, press this key to generate machining program.

8.4 . User Defined Module

User is allowed to customize module with the following method .

- 1) Firstly, it is required to edit a standard program for the self-defined module and name it as TK17S.NC, which should have the following structure:
G92 X0 Y0 // User-defined module, Note: The original program should not have more than 59 lines.
G28 // The last line should command the torch to return to the reference point.
M02
- 2) Simply copy this program into the file system. The 17th pattern element is self-defined. If no new module is self-defined, the system will take the old module automatically.
- 3) This module is allowed to use for Layout and Rotate features, but no parameter to set .

Chapter IV. Diagnose

In the system main menu, press [F5] to enter DIAGNIZE main window, as shown in the figure below:

OUT:		M10	M12	M14	M16	M38	M20	M22	M24
Output state		0	0	0	0	0	0	0	0
INPUT:		LWP	LWN	DUP	DDN	DLZ	STO	PAS	LDW
Input state		1	1	1	1	1	1	1	1
		SXP	SXN	SYP	SYN	PRE	SPP	SPN	CHE
		0	1	0	0	0	0	0	0

In Plasma Operation

OUT:		M38	M12	M14	M16	M10	M20	M22	M24
		0	0	0	0	0	0	0	0
INPUT:		LWP	LWN	DUP	DDN	DLZ	STO	PAS	LDW
		1	1	1	1	1	1	1	1
		SXP	SXN	SYP	SYN	PRE	SPP	SPN	CHE
		0	1	0	0	0	0	0	0

In Flame Operation

9.1 Check Input/output Ports

The system diagnosis will show the hardware resources available. In DIAGNOSE window, it is allowed to check the state of input/output port.

9.2 Output Check

Move cursor to any position of the 8 optical isolation output ports and change the level state of output with "0" and "1". 1 stands for enable while 0 stands for disable. Refer to "Definitions of Input/output Port" for the definitions of output ports.

9.3 Input Check

Let the system to show the state of active optical isolation input ports. 0 stands for low potential (grounding) while 1 stands for high potential (24V or overhead). See "Definitions of Input/output Ports" for the symbol definitions of input ports.

Chapter X. Connections of Input/output Ports

The system ports include input ports(DB25 pin), output ports(DB25 pin), motor(15 pin) and RS232 serial port(15 pin) to connect the height controller manufactured by Microstep.

10.1. System Input Principle

Generally, mechanical switch is used for travel limit/start/pause. To shield the system from interference, normally-closed contact is usually used for mechanical switch, which is connected with the way described below.

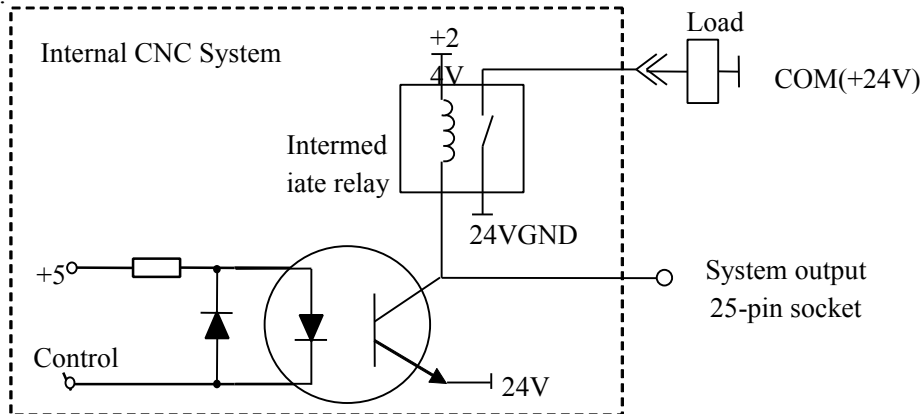

Notes:

- The logic for emergency stop, pause and travel limit of the system is the same, i.e., they are all connected to normally-opened contact(NO contact) or normally-closed contact(NC contact).
- After powered on, the system will automatically check the level of activation bit as control reference.
- Therefore, if external start switch is not connected, the corresponding activation bit should be connected to 24V ground (similar to connection to NC contact) or nothing(similar to connection to NO contact).

10.2. System Output Principle

Notes:

Control signal = 0 switch/relay on(+24V circuit on, low effect and sign transmission)

Control signal = 1: switch/relay off(+24V circuit off and no sign transmission)

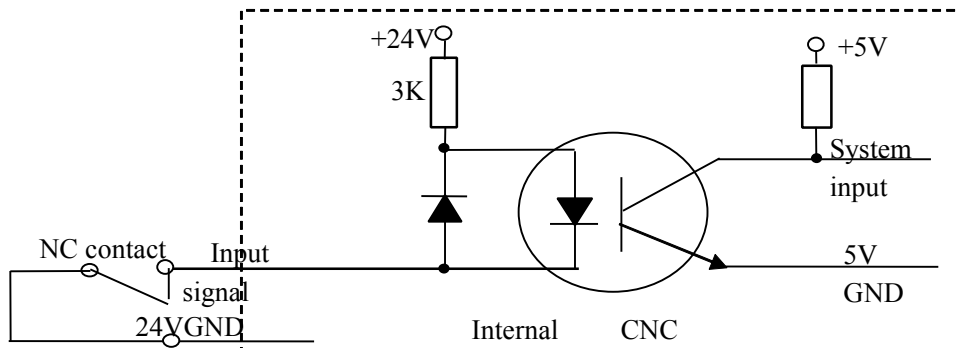

10.3 Definitions of Input/Output Ports

Signal definition	25-pin port(socket)	Description
>W+	1	X/Y+ limits, two positive axial travel limits connected in series, high priority. Please jump the signal to 24V ground if not use.
W-<	14	X/Y-limits, two negative axial travel limits connected in series, high priority. Please jump the signal to 24V ground if not use.
STA	2	External starting key, high in effect. Please jump the signal to 24V ground if not use.
RET	15	External backspace key, high priority. Please jump the signal to 24V ground if not use.
DLZ	3	Arc voltage test, normally low priority, but high priority when arc voltage is not enabled.
STO	16	External emergency stop key, high priority. Please jump it to 24V ground if not use.
PAU	4	External pause key, high priority. Please jump it to 24V ground if not use.
XXW	17	Lower limit for plasma torch positioning operation
	5	NO contact output of height-control corner signal relay(auto/manual switch for height control).
	18	NO contact output of arc ignition signal relay
	6	Common port for COM(OH1/OH2/OH3/OH4) isolation output
	19	NO contact for lowering operation(OH4) of cutting torch with height controller
	7	NO contact for lifting operation(OH3) of cutting torch with height controller
	20	NC contact for lowering operation(OH4) of cutting torch with height controller
	8	NC contact for lifting operation(OH3) of cutting torch with height controller
M10/M11 or M38/M39	21	Flame cutting: M38 height control; M38 for ON and M39 for OFF Plasma cutting: M10 reserve; M10 for ON and M11 for OFF
M20/M21	9	M20(ON) and M21(OFF). In flame mode, used for ignition switch; in plasma mode, always ON when ignition delay is 0 acting as flame/plasma selective switch.
M22/M23	22	Reserved
M24/M25	10	Reserved
	23	NC contact for corner(OH1)
	11	NC contact for cutting oxygen(OH2)
24V	24	+24V/1A power supply
24V	12	+24V/1A power supply
24V地	25	Ground for 24V power supply
24V地	13	Ground for 24V power supply

10.4 Definitions of 15-pin Ports for Motor

1. Differential Signal

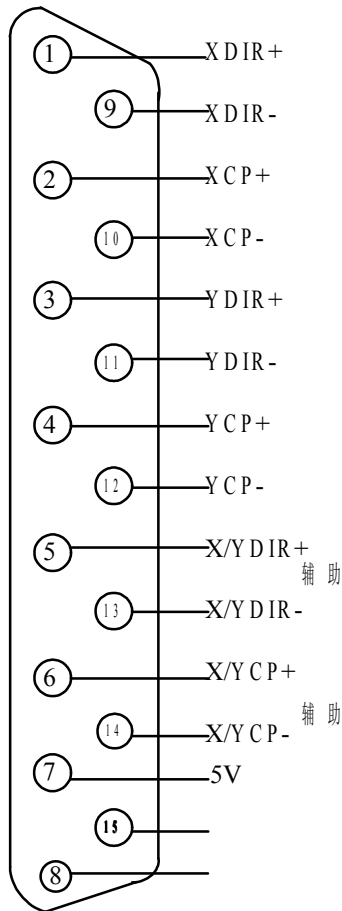

2. Common Anode Connection

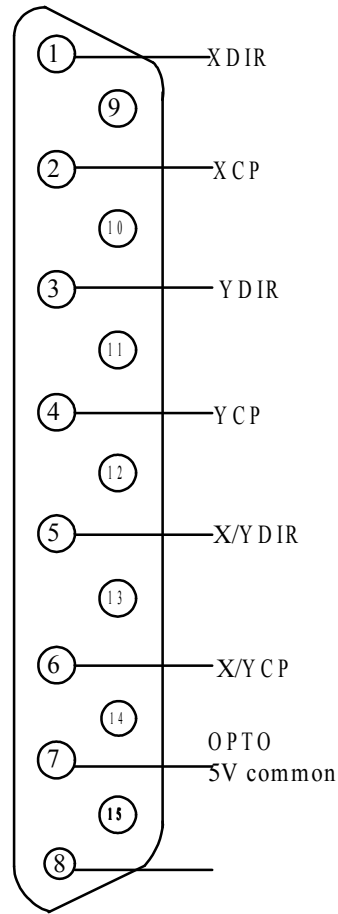

10.5 Typical Wiring for Flame Cutting Operation(DB15)

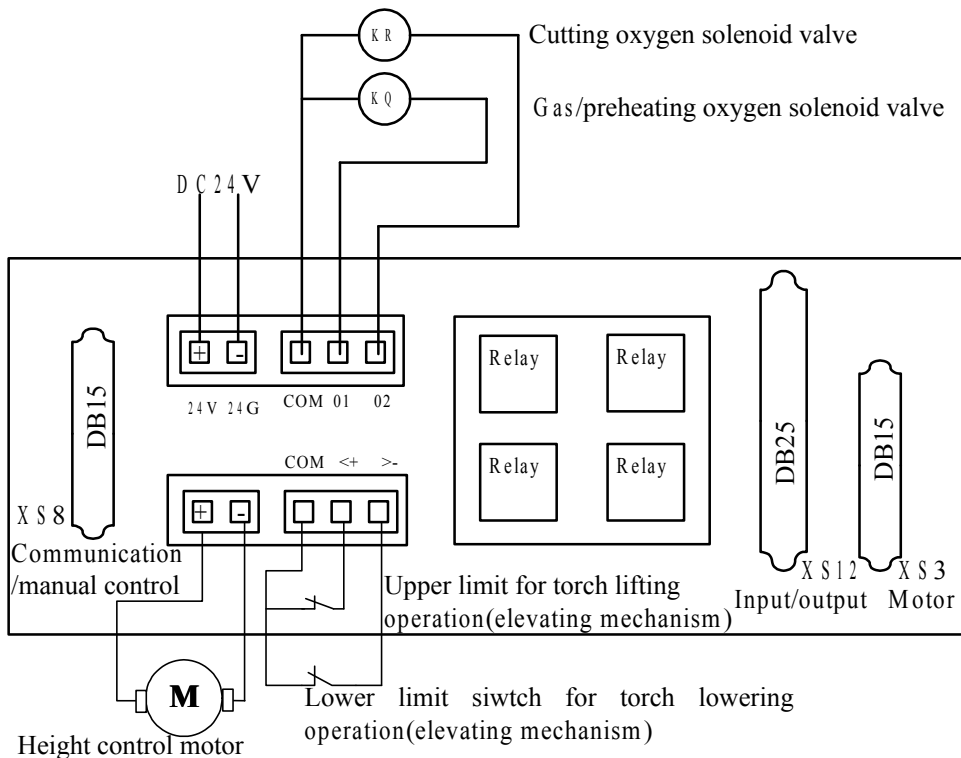

10.6 Typical Wiring for Plasma Arc Cutting Operation

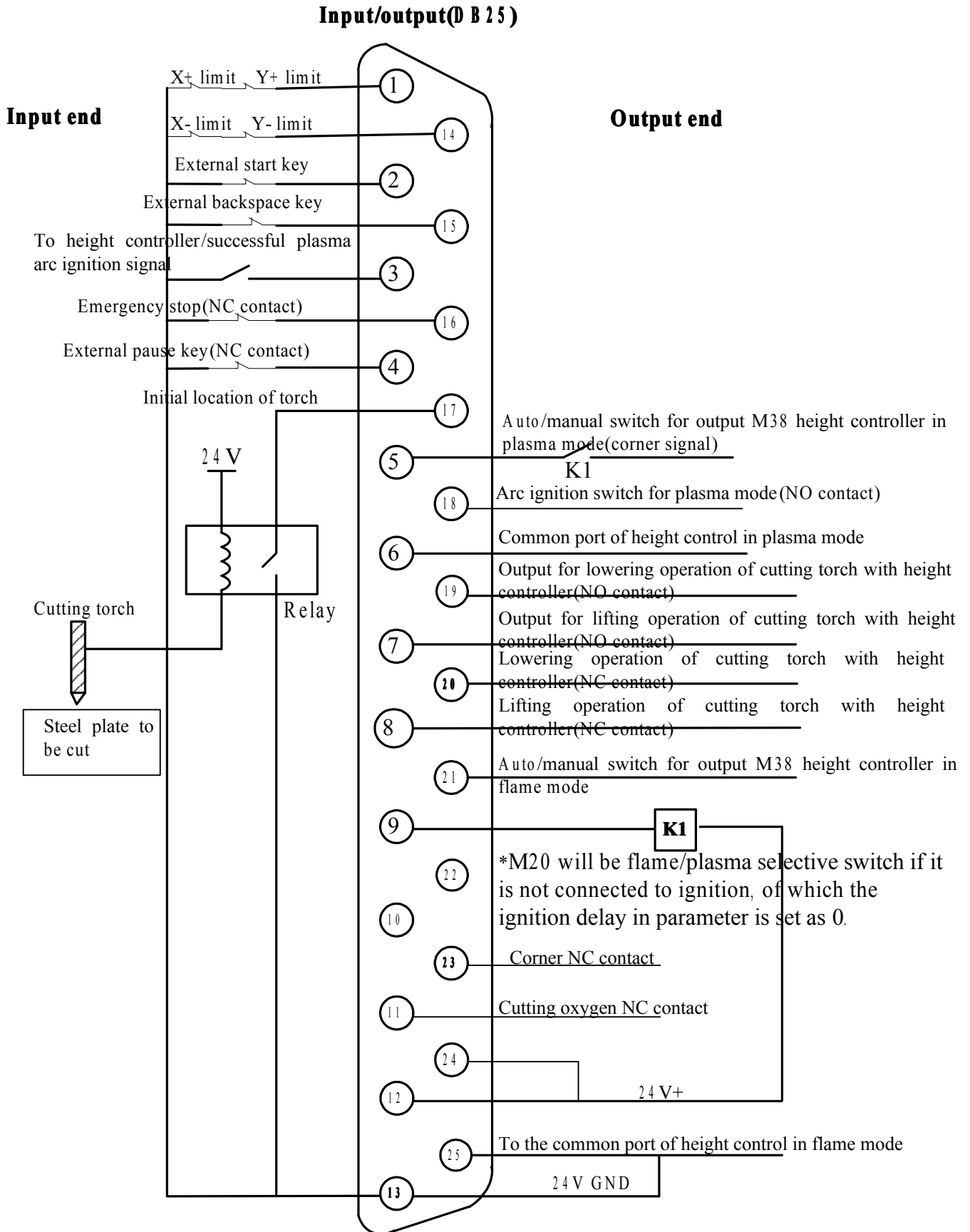

10.7 Compatible Connection for Flame/plasma Operations

When the system is required to connect both plasma and flame cutting torches, make the connections for plasma mode and flame mode respectively as described above and then provide a flame/plasma selective switch K1 with the connection method as shown in the diagram below.

- (1) KR is the solenoid valve for acetylene(gas)
- (2) KQ is the solenoid valve for cutting oxygen
- (3) If the solenoid valve for acetylene(gas) is not connected, then the gas contacts are not necessary to connect.
- (4) K1 is flame/plasma selective relay(M20)

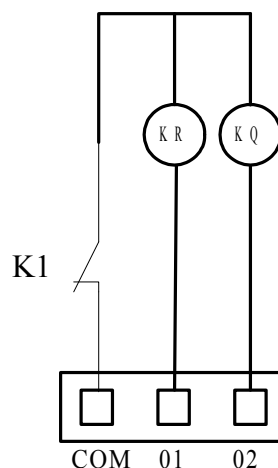

10.8 Pin Definitions

1. The pin definitions of 15-pin connector for Model SH-HC30 height controller manufactured by Microstep are as follows:

No.	Attribute	Description	Remarks
1	Serial common	232-COM	
2	Serial Rx	232-RXD	
3	Serial Tx	232-TXD	
4	Input signal	Arc voltage signal (height of cutting torch)	
5	Signal GND	Ground of arc voltage signal	
7. 14	Power supply	+ 24V power supply for height controller	
8. 15	Power supply	Ground of 24V power supply for height controller	
10	Input	Manual/auto selection signal	
12	Input	Manual lifting signal to drive the cutting torch up	
13	Input	Manual lowering signal to drive the cutting torch down	

2.Pin Definitions of XS8 for System Communication/Manual Control (DB15)

No.	Definitions	Description	Remarks
1	24V	24V power supply	
2	TXD	RS232 transmission	
3	RXD	RS232 receive	
8	24G	Ground for 24V power supply	
9	I8	Input Port 9 for External Control Box X+	
10	I9	Input Port 10 for External Control Box X-	
11	I10	Input Port 11 for External Control Box Y+	
12	I11	Input Port 12 for External Control Box Y-	
13	I12	Input Port 13 for piercing key of External Control Box	
15	24G	Ground for 24V power supply	

Appendix I: The Wiring Diagram and Pin Definitions for Model SH-HC30 Height Controller Manufactured by Microstep

1. Hybrid Wiring Diagram Compatible with Both Arc Voltage Type and Capacitance Type

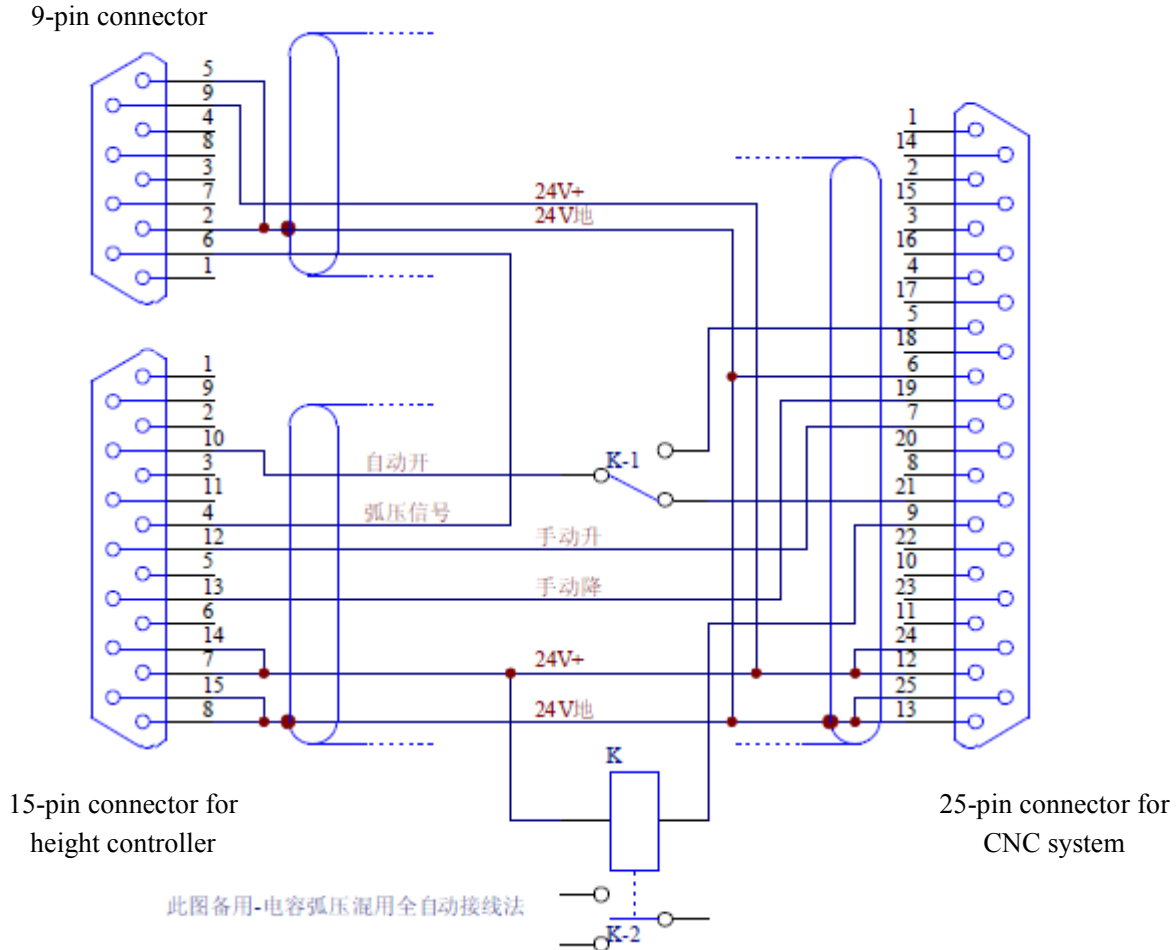

2. Pin Definitions List of 9 Pin Connector for Divider Board

No.	Attribute	Description
2	Power supply	Ground of 24V power supply for height controller
5	Power supply	Ground of 24V power supply for height controller
6	Output	Arc voltage signal for the height of plasma cutting torch
9	Power supply	+ 24V power supply for height controller

3. Wiring Diagram of Arc-voltage-type Height Controller

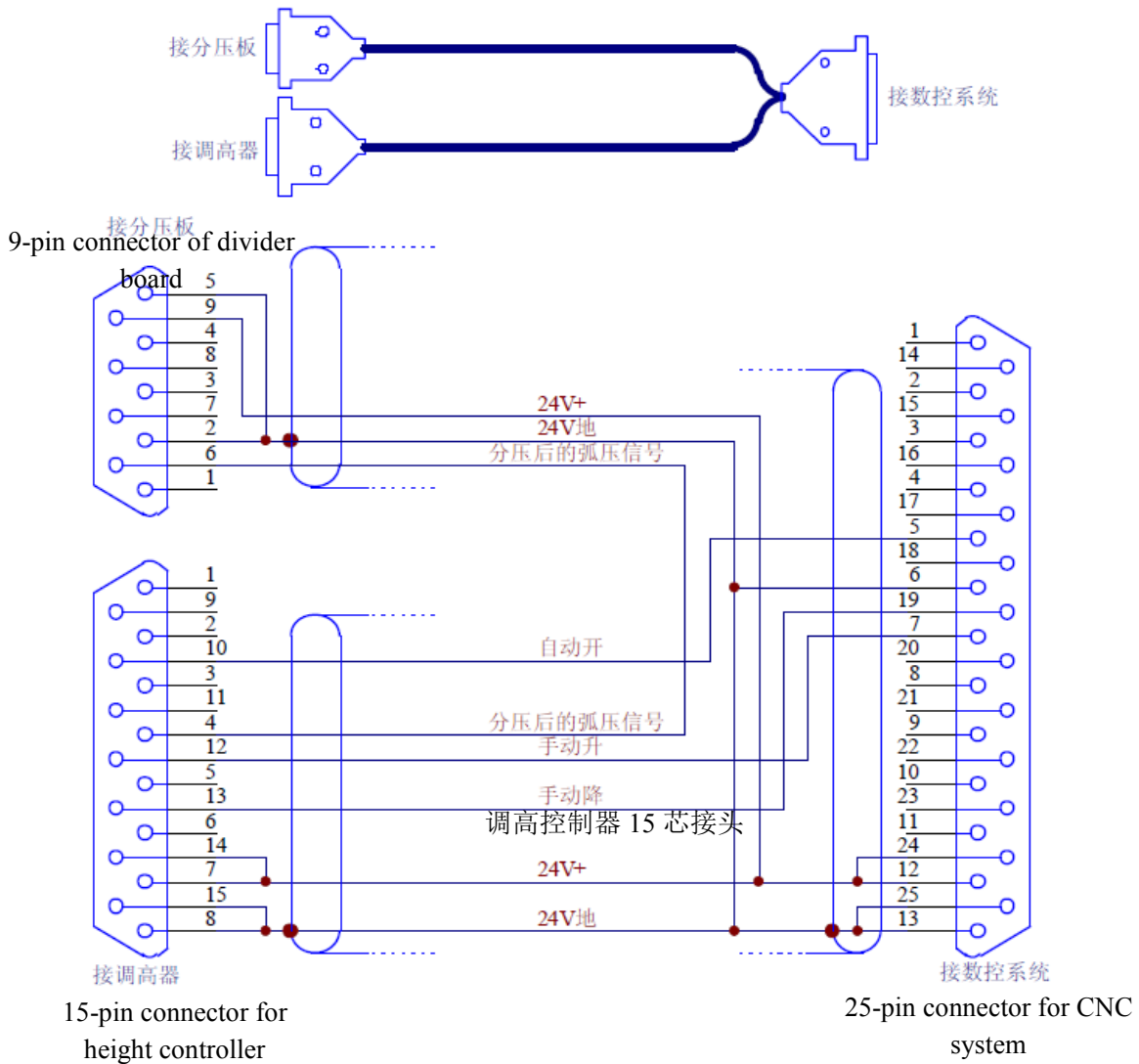

4. Wiring Diagram of Capacitance-type Height Controller

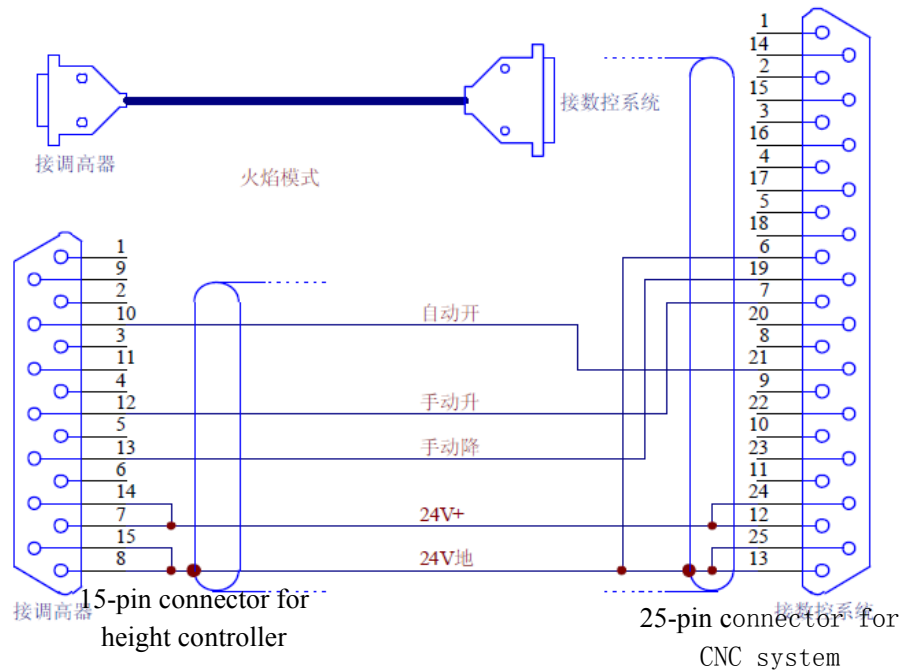

Appendix II: Instructions for Software Upgrading Operation of SH-2012AH

Functions:

The system software is allowed to upgrade through an USB disk.

The specific operation procedure is as follows:

1.File upgrading

Copy the upgrading file titled STARTCNC.EXE to an USB disk.

2.Operation procedure

Push and hold the button between the  red button 0 and the USB port.

Power the system on and release the  button when upgrading window appears on the display screen. Plug the USB disk into the port and press Key F1 under the display screen(the key corresponds to "**UPGRADE**" in the menu displayed). The system will automatically start upgrading operation.

3.Upgrading end

If program upgrading is successful, the system will prompt "Upgraded Successfully" and sound one beep. If program upgrading fails, the system will prompt "Upgrade Failure" and sound continuous beeps. ◦

4.New program startup

Power the system off and unplug the USB disk. Reboot the system to start up the upgraded program. The version number of the upgraded program will appear on the screen after booted up.

Notes:

Please make the following check if upgrading operation fails.

- 1) The USB disk must be **FAT or FAT32 format**. FAT format is preferable.
- 2) The upgrading file must be titled as **STARTCNC.EXE**.
- 3) If no prompt appears in the upgrading process and the display returns to the main upgrading window or upgrading operation fails due to any other interruption, verify first the name of upgrading file and the format of USB disk. If these two factors are assured, try to upgraded the program again following the specific operation procedure.

If program upgrading failure insists, please contact the Customer Service Department of Beijing Start M&E Technology Development Co., Ltd.

Appendix III: Installation Dimensional Drawing

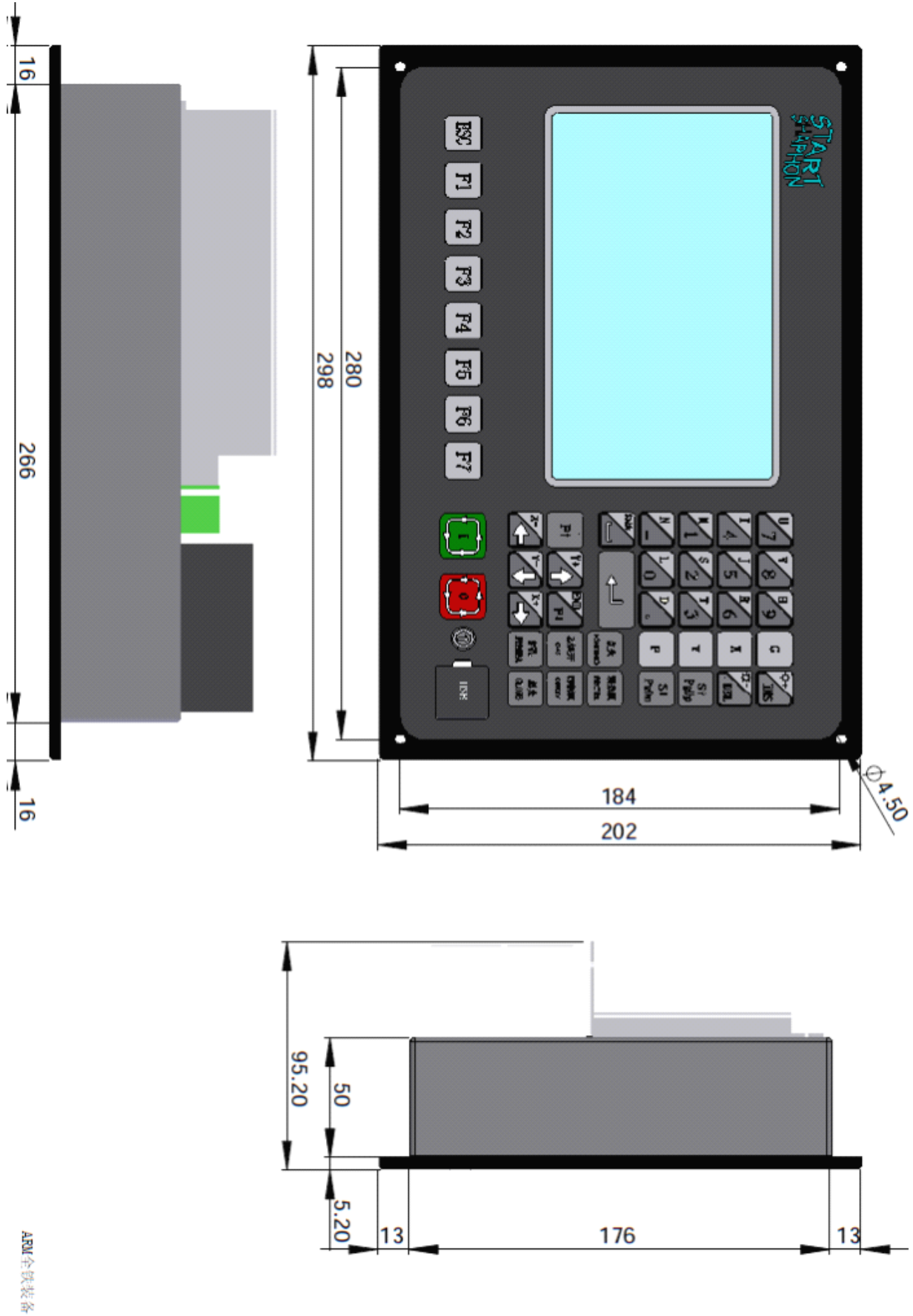

Appendix IV: Troubleshooting

Fault Symptoms	Fault Check	Fault Analysis	Recommended Solutions
Suddenly breakdown in normal operation	Always stop at the same position in every operation cycle	a. Machining program at fault b. CNC software at fault	Dispatch the software back to the manufacturer for professional troubleshooting.
	The system still runs but the cutting torch stops abnormally along all axes or one axis.	a The travel motor is locked. b The travel motor fails.	Check if the machine is frozen and level enough.
	The system still runs but the cutting torch does not move along one axis any more and gives no response to any keystroke, especially to the pause key.	The machine operation is interrupted.	a. Remove the interference and make sure the grounding wire of plasma power supply is connected to the machine. b. Check if the motor(previous model) has isolation board or not. c. If it is flame mode, check if the solenoid valve for cutting oxygen is given arc extinction.
Motor fails to run	Check the system wiring.	Loose connection or disconnection	Secure the connection.
	Check the driver.	Check for any alarm message or if the setting is correct or not.	Change the setting of driver.
	Check system setting.	Check if the start speed is zero or too high, the speed regulation time is too short and the electronic gear or pulse equivalency is appropriate to be zero.	Suggest to record the original parameters before making any modification.
	Check for axle problem and if the same model of motor is available.	Replace parts one by one to isolate the real cause to the problem.	Replace the broken part.
Slow system response	Check the power supply.	Check if the output voltage of power supply is within the allowable range.	Adjust the output voltage or replace the power supply for switch.
	Check the system parameters for any error.		Suggest to record the original parameters before making any modification.
Travel limit alarm at power-on	Check if any external limit switch is connected.	Check if limit switches are functional and if loose connection or disconnection exists.	Secure the connection.

		If no external limit switch is connected, check the system if the current coordinate values are too high and out of the travel limit set by software. Check if the travel limit set by software is too small.	Modify it to normal range.
	In DIAGNOSE window, trigger the external limit switch.	Check for any change with the corresponding input port.	
No response to keystroke or wrong key assignments	Check the cable for keyboard.	Check if the keyboard is loosely connected or disconnected.	Secure the connection.
The system is locked up in manual/automatic mode.	Incorrect parameter setting.		Record the electronic gear in system parameters and then press G, G and 3 in the system main window successively. Save the parameters in parameter setting mode. Restart the system and fill the recorded value of electronic gear into the corresponding position. Save the parameter and test the system performance.
No input/output	Check the cables for input and output.	Check if they are well connected.	Secure the connection.
	Check if 24V power supply is normal or not.	Check the voltage of 25-pin port between Pin 24 and Pin 25.	Check the switching power supply.
	Check the cables inside the system for any loose connection.		Secure the connection.
Blank screen	Adjust "+" key and "-" key at the upper right corner of keyboard for proper contrast and check for any screen display.	If yes, adjust the contrast to normal display.	Make readjustment.
		If not, check the cables for LCD for any loose connection.	Secure the connection.
USB transmission failure	USB disk is not compatible with the system.		Try the USB disk of other model or brand.
	Incorrect format of USB disk		Reformat the USB disk to FAT format.
	Check the lamp indicator of USB port for any light.	Check the cables inside the system for any loose connection; check the USB port for any foreign material and all the pins are in normal condition.	Secure the connection and remove foreign material from the port.
The system returns to the program	Replace the machining program and test running	If the problem is gone, it means that machining program	Check the program.

main window after machining program is started.	the system; initialize the system if any parametric problem.	ram has bug.	
The system can only machine straight line and fail to machine a circle.	Initialize the system if an any parametric problem		Initialize the system parameters.
	Replace the machining program and test run again.	If no more problem, check that machining program.	Check the program or return it to the manufacturer for diagnosis.
Screen blinks when a solenoid valve is opened or plasma arc ignition is going on.	<p>a. The power supply unit for plasma, CNC system and the enclosure of machine must share a ground wire that is 2mm thick at least in diameter and well connected to the ground.</p> <p>b. Shielded cables must be used for the system input/output and the exposed part at the cable end must not be longer than 30mm.</p> <p>c. The unused input end must be connected to 24V ground wire.</p> <p>d. A 0.01uF capacitor should be used between the 24V ground wire and enclosure(shielded cable).</p> <p>e. Use an isolation transformer(380V-220V) and as interference suppressor if it is possible.</p> <p>f. Separate the operational power supply for high-power welding machine/cutting machine from that for CNC system.</p>		
Failure to save the program clobber	Failure to save the program.		After replacing batteries, press G, G and 3 in the system main window successively to format the program area.
No system output	Check if 24V power supply is normal or not.	Measure the voltage between Pin 24 and Pin 25.	Check and replace the switching power supply unit.
	Check if the four relays on the rear panel are reliably connected, if the relay operation is normal and if the contact is functional.		Replug or replace the relays.

Appendix V: Wiring Instructions for Extended External Manual Control Box

The system is allowed to connect a handheld (or wireless) external control box through 8 input ports. The wiring instructions are as follows:

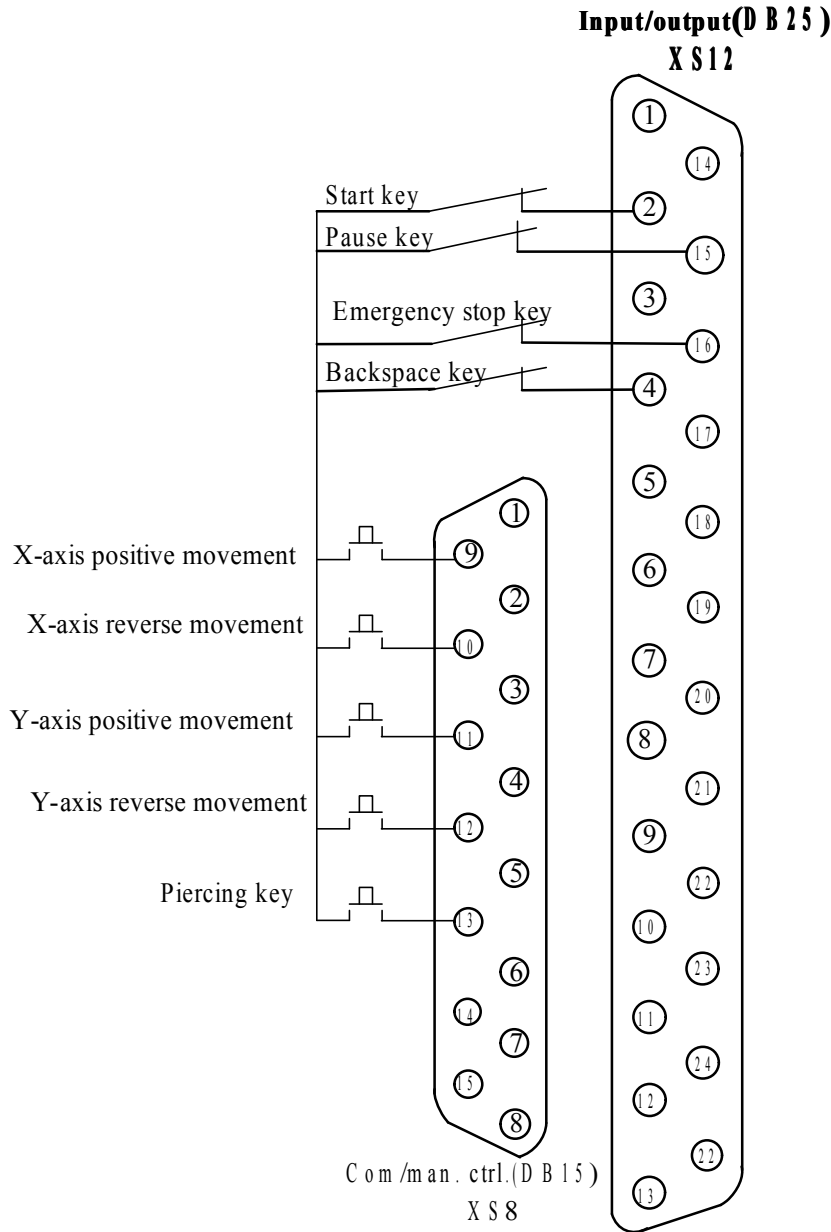

Notes:

1. The start key, pause key, emergency stop key and backspace key are required to connect to the input/output port through normally-closed contacts. These four keys are enabled at system booting and not affected by the possibility if the external manual control box is enabled or not.
2. X+, X-, Y+ and Y- piercing keys are connected to the system auxiliary connector (DB15), which are required all to use normally-closed contact or normally-opened contact. It means the logic of the 5 ports must be the same, all NO contact or all NC contact. The availability of these 5 external control keys depends on the option of external manual control box for height controller in parameter setting. When the option is enabled, they will function.