

# Coal Feed Systems For Boiler and Coal Milling Plant

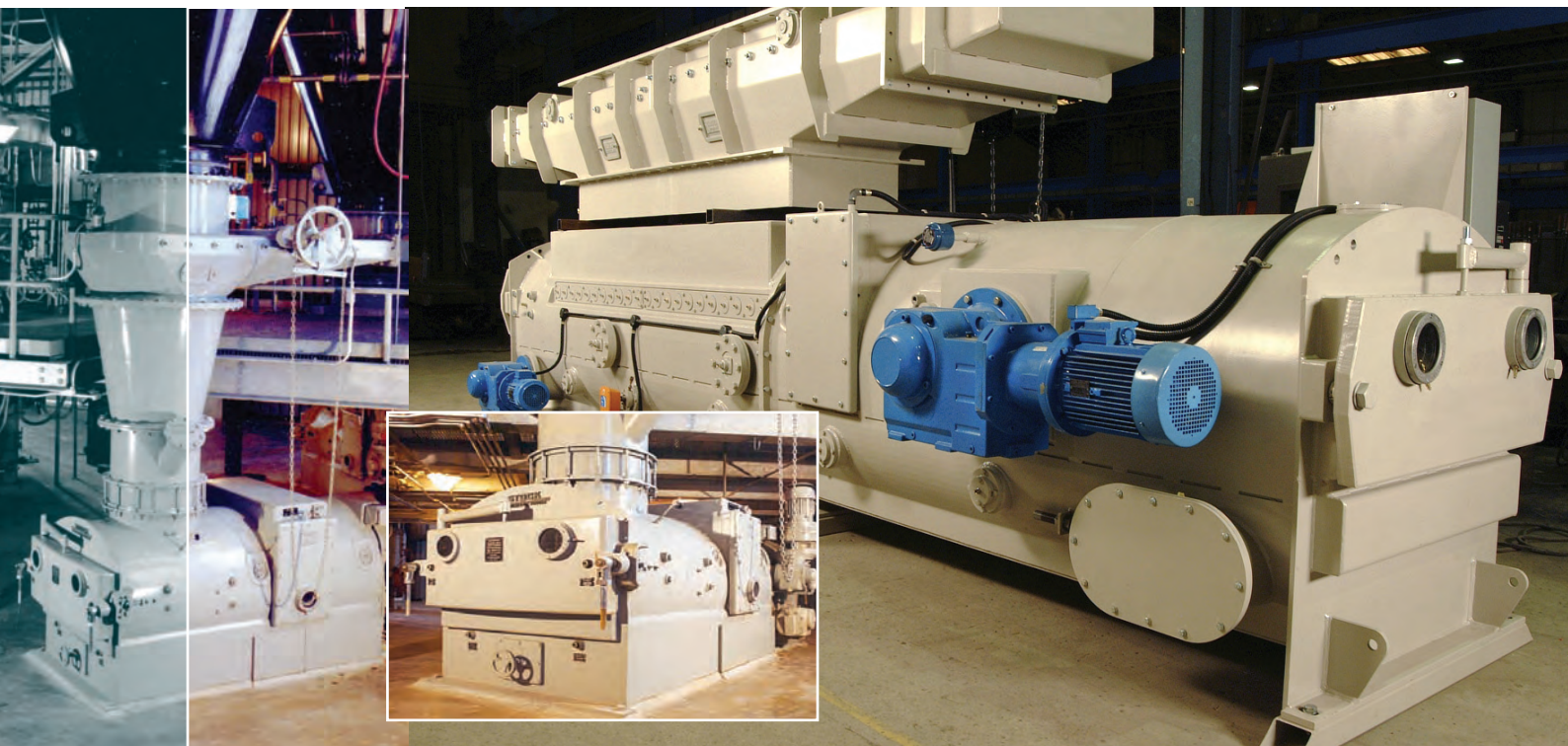

Gravimetric and Volumetric Systems Belt and Chain Type Feeders

- Stock Equipment Company established in 1929
- First Gravimetric Coal Feeder (1957) designated as ASME Historic Landmark in 1995
- More Feed System installations than all competitors combined

 <p>8,000 Feeders supplied worldwide</p>	<ul style="list-style-type: none"> <li>■ Australia</li> <li>■ Canada</li> <li>■ Chile</li> <li>■ China</li> <li>■ Columbia</li> <li>■ Costa Rica</li> <li>■ Czech Republic</li> <li>■ Dominican Republic</li> <li>■ Guatemala</li> </ul>	<ul style="list-style-type: none"> <li>■ Hong Kong</li> <li>■ India</li> <li>■ Indonesia</li> <li>■ Ireland</li> <li>■ Israel</li> <li>■ Italy</li> <li>■ Japan</li> <li>■ Korea</li> <li>■ Malaysia</li> </ul>	<ul style="list-style-type: none"> <li>■ Mexico</li> <li>■ Morocco</li> <li>■ Netherlands</li> <li>■ New Zealand</li> <li>■ Pakistan</li> <li>■ Philippines</li> <li>■ Portugal</li> <li>■ South Africa</li> <li>■ Spain</li> </ul>	<ul style="list-style-type: none"> <li>■ Taiwan</li> <li>■ Thailand</li> <li>■ Turkey</li> <li>■ United Kingdom</li> <li>■ United States</li> <li>■ Ukraine</li> <li>■ Venezuela</li> <li>■ Vietnam</li> <li>■ Zimbabwe</li> </ul>
---	--	---	---	--

- Proven reliability and long life in numerous applications
- Technically superior design
- Complete bunker to pulverizer system supply

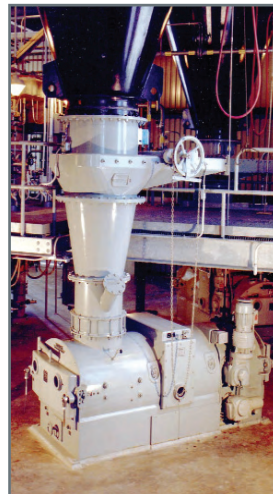
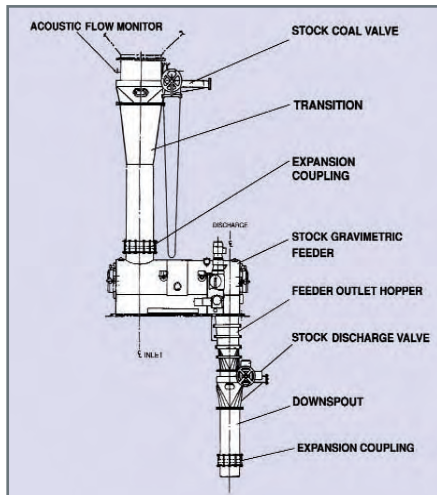

- Unparalleled customer aftermarket support
- World wide manufacturing facilities
- Factory trained and highly experienced field service personnel
- ISO 9001 Quality Certification
- Total service from parts supply to turnkey installations
- Test Tower eliminates field R&D

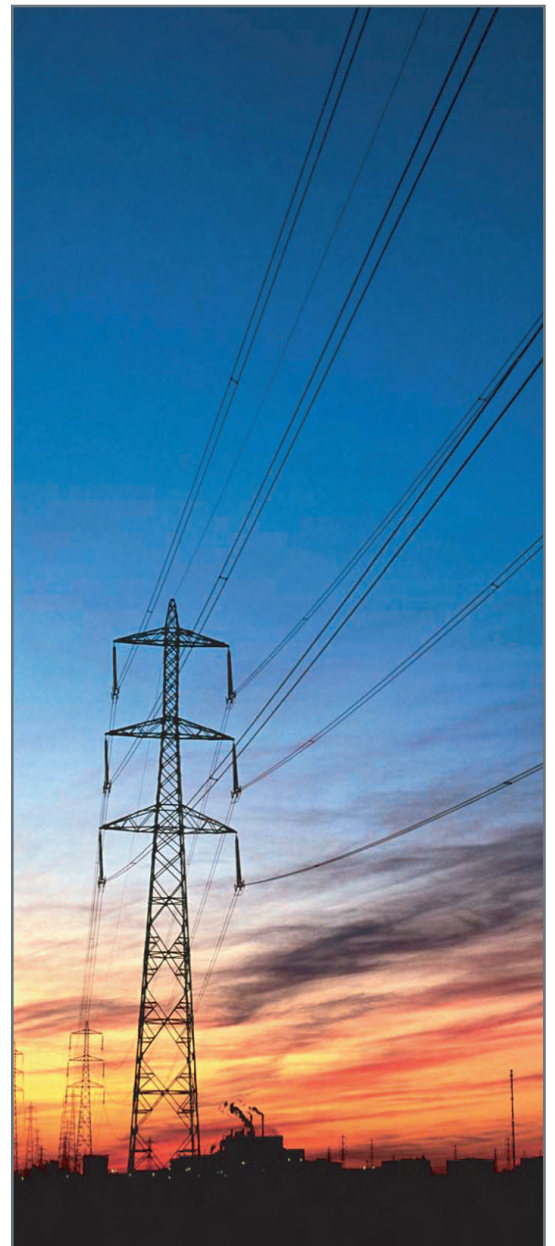

# The Composite Gravimetric Feeder

## For close centred applications

- The arrangement and geometry of the bunker/feeder/mill has implications for the design of a Gravimetric Feeder, in both new and retrofit applications
- A typical arrangement is shown, whereby the centre line of the feed to the mill is inside the line of the bunker outlet.
- Also note that an emergency discharge facility is also required. (This tends to be an important feature, especially where volatile coals are being used and the residence time of the bunker is limited).

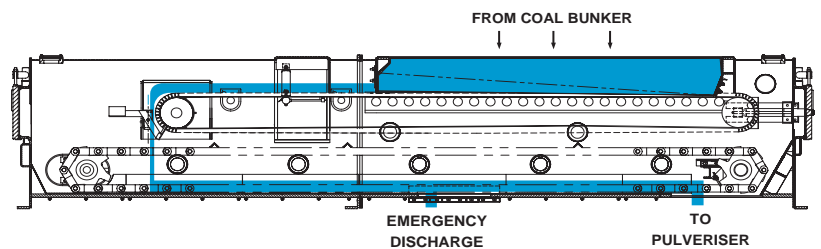
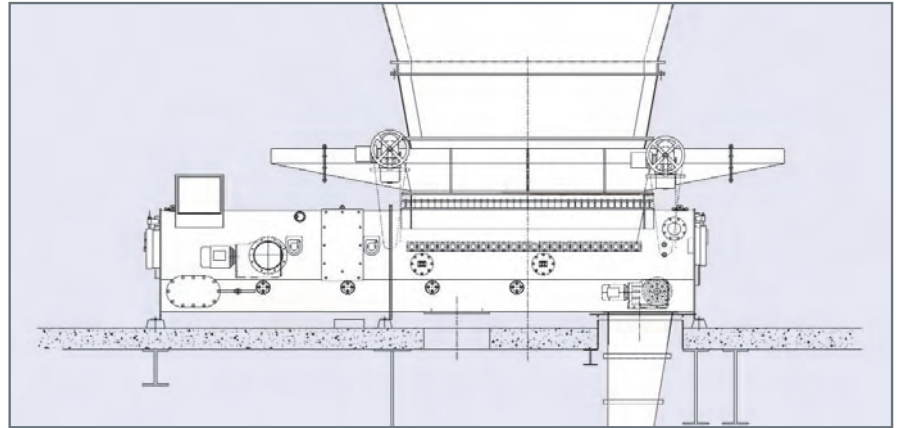

The Gravimetric Feeder can be adapted to meet these dimensional constraints by applying the REDLER knowledge of conveying coal with a chain into a STOCK Gravimetric Feeder giving a most suitable and practical design of feeder to deal with short centreline dimensions from inlet to outlet.



- Composite Gravimetric Feeder:  
To handle up to 70 tonnes/hr of coal.
- Installed in a UK Power Station to replace an existing volumetric feeder
- The Chain Conveyor in the lower part of the Feeder receives fuel from the Weigh Belt Unit and the discharge can be arranged at any point along the Feeder length. This arrangement suits applications for retrofitting that are being encountered

## Bunker Gates

- Custom designed to suit wide range of bunker sizes
- Designed to close through a standing column of coal
- Manual or Power operation



# Typical Feeder Arrangements



## The Standard Gravimetric Coal Feeder

- Designed to withstand 3.5 bar g explosion pressure per NFPA code 85
- 2.1 m minimum centres inlet to outlet
- 610 and 915mm inlet downspout sizes
- Capacities over 100 tonnes/hr
- Weighing Accuracy +/- 0.5%

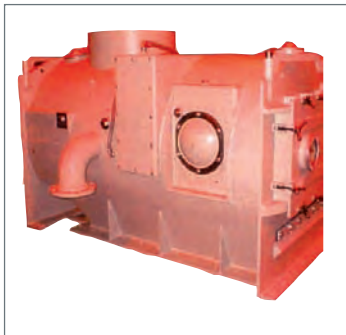

## The Compact Gravimetric Coal Feeder

- 3.5 bar g explosion pressure containment
- 1.22m centres inlet to outlet
- Weighing Accuracy +/- 1.0%
- Capacities up to 100 tonnes / hour



## The Low Pressure Gravimetric Coal Feeder

- Used on Fluid Bed Boiler Boilers to deliver coal and limestone
- Suitable for pressure up to 0.2 bar g



## Volumetric Belt Feeders

- All the major features of the Gravimetric Feeder, without the load cell weighing system
- Minimum 610mm centres of inlet to outlet



## Volumetric Chain Feeders

- Designed to withstand 3.5 bar g explosion pressure per NFPA code 85
- Fitted with Redler heavy duty chain
- Capacities over 100 tonnes/hr

# Why Gravimetric Feeding of Coal?

Because of the heterogeneity of coal, gravimetric feed systems have a number of advantages over volumetric systems when it comes to achieving optimized combustion in pulverized coal fired power plants, with lower emissions. Gravimetric systems are widely used in the USA, volumetric feeders currently predominate in Europe, but with the growing pressure to reduce emissions this is likely to change.

When firing coal, there is currently no effective way to measure kilojoule (BTU) flow, so this value must be inferred from either volume or weight flow. The volume flow measurement will be in error by the variation in both density and heating value, whereas the weight flow signal will be in error only to the extent of the variation in heating value. The gravimetric feeder is vital if an accurate flow rate is to be maintained irrespective of density changes.

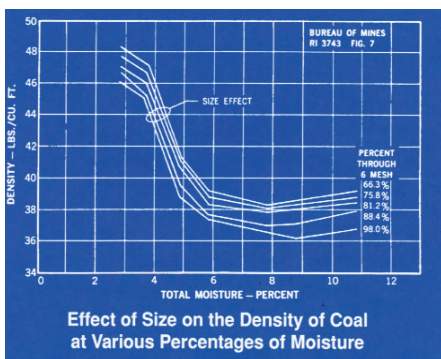

Maintaining the correct amount of coal to the pulverizer is not a simple task since the coal properties constantly vary due to sizing differences and the adverse impact of moisture on heating value, flow characteristics, and density. The effects of moisture on coal has been studied for many years with research conducted by many

institutes, who have published data illustrating how coal density decreases with increasing moisture levels within the ranges typically experienced at coal fired power plants. The effects of moisture is also dependent upon the particle sizing of coal which generally reflects a lower density level for smaller sizes.

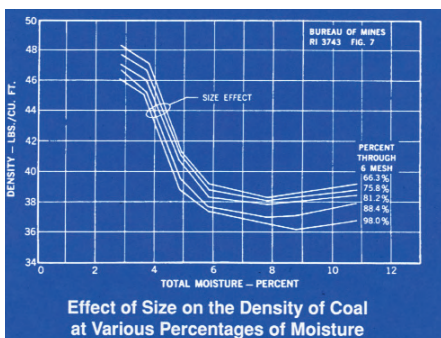

The differences in the amount of coal delivered to the pulverizer and hence the burners by a volumetric and gravimetric feeder are illustrated on this chart.

- Summary of Benefits**
- Fuel Savings through Improved Boiler Efficiency
  - Improved Combustion Efficiency/LOI
  - Improved Pressure and Superheat Control
  - Less Slagging and Pluggage
  - Less NOx through Better Control of Excess Air
  - Less Corrosion
  - Stability and Improved Response of Combustion Controls
  - Reduced O&M costs
  - Improved Coal Mill Performance
  - Safety

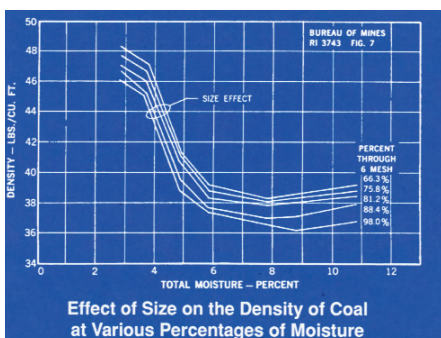

Due to the difficulties in burning coal, it is necessary for excess combustion air to be added to the furnace in order to ensure safe and complete burning of the fuel. This excess air is typically 15% to 18% depending upon the volatile content of the fuel.

Variations in the amount of fuel delivered to the burners due to density changes and the feeders accuracy also requires additional air to avoid loss of carbon and unsafe conditions within the furnace. This additional air goes up the stack and represents an efficiency loss for the plant.

## Gravimetric Feeder Principle

- The gravimetric feeder weighs material on a length of belt between two fixed rollers using a weighing roller.
- Belt speed is determined by a tachometer attached to the motor shaft. A microprocessor multiplies the speed and weight signal to arrive at the feeder output.
- The microprocessor matches the feeder output to the demanded output by adjusting the feeder motor speed.

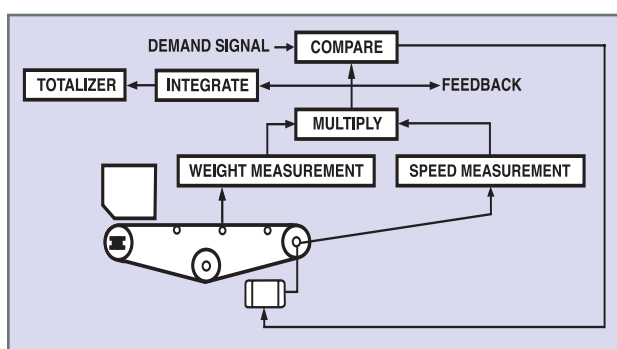

# Feeder Construction and Features

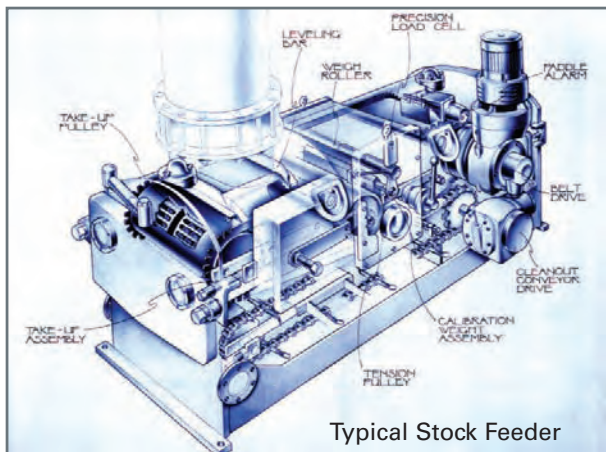

## Accuracy

Accurate fuel delivery ensures stable combustion control and rapid response to changes in boiler load. The STOCK® gravimetric feeder is designed to provide uninterrupted fuel delivery with a feed rate accuracy of  $\pm 0.5\%$ . Proven accuracy and reliability have been demonstrated over decades of practical experience.

## Dual Load Cell Weighing System

Dual load cells combine maximum accuracy with reliability. The outputs are checked against each other prior to transmission to the feed rate circuitry.

Excessive deviation or an unreasonable signal results in immediate and automatic transfer to a volumetric feed mode without interruption of flow

## ACCUFLEX® Feeder Belt

ACCUFLEX is a mechanically spliced, single-ply feeder belt that enhances long-term feeder accuracy, has the strength of a two-ply belt, and is easily installed. A molded V-guide maintains proper tracking. Molded, notched belt curbs minimize dust spillage.



## Weighted Belt Scraper

The scraper effectively cleans the outside of the belt.

## Alarms

Alarms are located downstream from the feeder inlet, and at the feeder discharge, to indicate the presence of coal on the feeder belt and to detect coal pluggage to the mill.

## Feeder Inlet

The feeder inlet is constructed of solid, type 304, stainless steel. A replaceable stainless steel levelling bar shears the coal column, forming a uniform profile of coal on the belt necessary for accurate weighing.



## Head Pulley

The pulley is machined flat to within 0.13mm T.I.R. A multiple pin and bushing coupling simplifies pulley removal.

## Take –Up Pulley

The pulley body is slotted and contains an internal helix to provide self-cleaning operation. The pulley face is also crowned to facilitate belt tracking.

## Belt Tension/Take –Up

Belt tracking and tensioning are accomplished by means of a unique take-up assembly consisting of two externally operated stainless steel, spring-loaded screws. The take-up screws have hex heads to accommodate a ratchet wrench.

## Cleanout Conveyor

Malleable iron drag chain continuously clean any dust accumulation from bottom of the feeder.

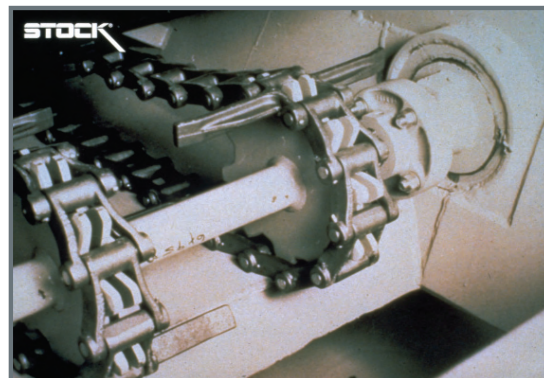

## Internal Illumination (Optional)

Work lights located at each end of the feeder provide excellent illumination of the feeder interior. Light bulbs can easily be changed from outside the feeder body without disrupting the pressure integrity of the feeder shell.

## Body shell

The 8mm thick carbon steel construction exceeds NFPA Code 85 Boiler Code requirements of 50 psi (3.5 bar g) explosion pressure containment. All parts that contact the active coal flow are fabricated of type 304 stainless steel or rubber.

## Access Doors

Large access doors are designed for easy entry and convenient feeder maintenance. Each end door is secured with heavy duty fasteners for rapid entry. Two glass ports are located in each end door for viewing belt tracking and coal flow.

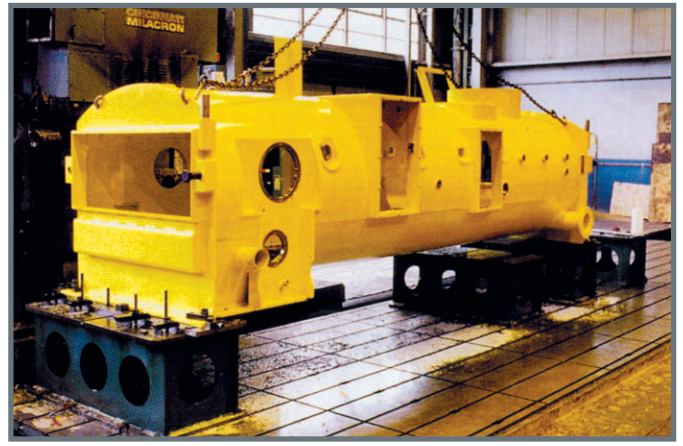

■ Shell Being Machined

# The Feeder Controller

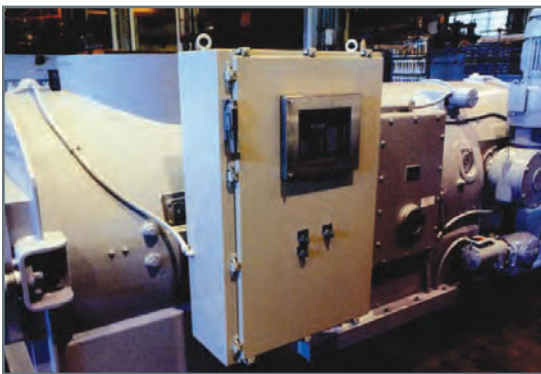

- The STOCK 196NT microprocessor system is a refinement of proven electronic controls designed to operate in power plant environments where harsh conditions and frequent power disturbance exists.
- Special circuits, software subroutines and nonvolatile memories for process data are utilised for maximum system availability and performance.
- The controls are housed in enclosures rated NEMA 4 or better.

Two-line vacuum fluorescent display with forty alphanumeric characters per line

LED indicators on MODE keys

Functional grouping of keyboard into five areas-Calibration, Mode, Programming, Operation, and Status

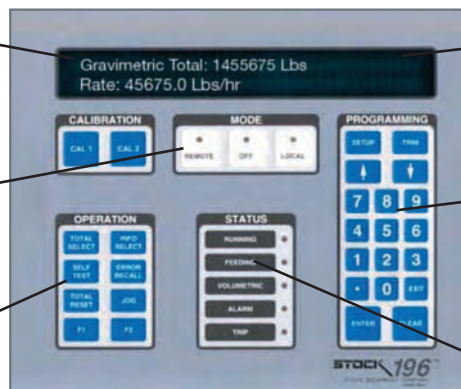

Numbers displayed with a label (Rated) and selectable engineering units (Lbs/hr)

Environmentally sealed membrane switch keyboard

Thirty-one embossed function keys with tactile feedback

LED indicators for system STATUS

## Features:

- An alphanumeric display that clearly communicates text messages to the operator, reducing the use of the operating manuals
- Highly integrated electronics which result in fewer components and improved reliability
- Hourly calibration of load cell circuitry is performed automatically and eliminates system drifts due to time and temperature
- Keyboard designed for simplified operator interface allows direct entry and recall of site-specific parameters
- All operating information and program data stored in non-volatile memory without requiring battery backup
- Built-in diagnostics to assist in system troubleshooting
- Designed for long-term accuracy without frequent calibration. Calibration is performed by the microprocessor and the procedure is fast, accurate, and automatic.

**weighing**

**feeding**

**conveying**

**automation**

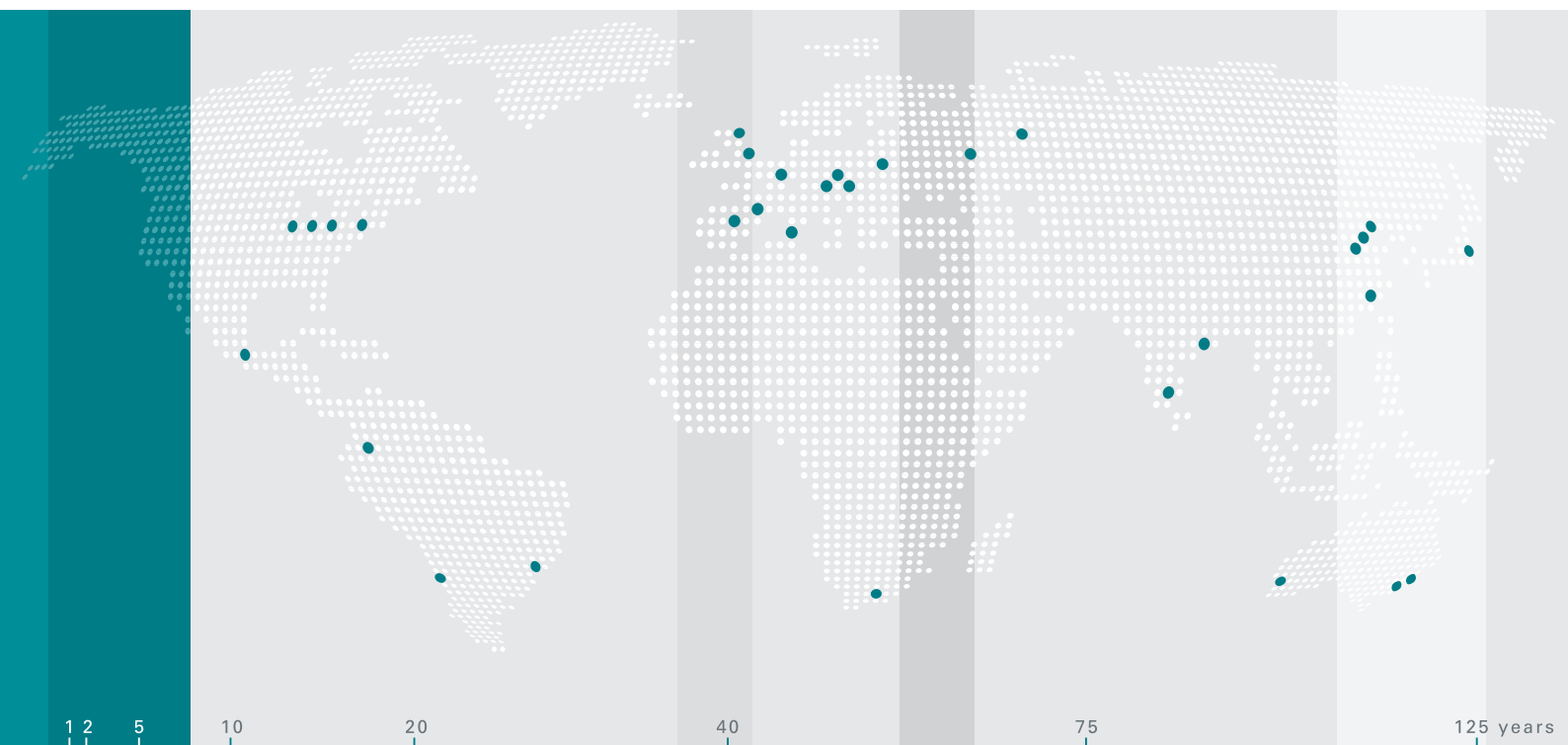

Stock Redler Limited  
Redler House  
Dudbridge, Stroud  
Gloucestershire  
GL5 3EY England  
T +44 (0) 1453 763 611  
F +44 (0) 1453 763 582  
sales@redler.com

Schenck Process GmbH  
Pallaswiesenstraße 100  
64293 Darmstadt  
Germany  
T +49 61 51-32 10 28  
F +49 61 51-32 11 72  
sales@schenckprocess.com



**we make processes work**