

Commercial CO₂ Refrigeration Systems

Guide for Subcritical and Transcritical CO₂ Applications



EMERSON[™]
Climate Technologies

Contents

Chapter 1. Introduction	4
Chapter 2. CO₂ Basics and Considerations as a Refrigerant	5
Section 1. Criteria for Refrigerant Selection.....	5
Section 2. Properties of R-744.....	6
Section 3. An Introduction to Transcritical Operation.....	8
Section 4. Behaviour in the Reference Cycle.....	9
Section 5. R-744 Hazards.....	9
Section 6. Comparison of R-744 with other Refrigerants.....	11
Section 7. Advantages and Disadvantages of R-744 as a Refrigerant.....	12
Chapter 3. Introduction to R-744 Systems	13
Section 1. Introduction to Retail Transcritical Systems.....	13
Section 2. Introduction to Retail Cascade Systems.....	16
Section 3. Secondary Systems.....	17
Section 4. Selecting the Best System – Booster vs Cascade vs Secondary.....	18
Chapter 4. R7-44 System Design	21
Section 1. Transcritical Booster Systems.....	21
Section 2. Cascade Systems.....	23
Section 3. Secondary Systems.....	25
Section 4. Design for Pressure.....	26
Section 5. Design for Ease of Service.....	27
Section 6. Fixed Leak Detection.....	27
Section 7. Cooling Capacity.....	27
Section 8. Capacity Modulation.....	28
Section 9. Pipe Work and Jointing.....	28
Section 10. Lubricants and Oil Return.....	30
Section 11. Materials.....	30
Section 12. Potential for Heat Reclaim.....	30
Chapter 5. R-744 Systems - Installation, Commissioning and Service	31
Section 1. Good Installation Practice.....	31
Section 2. Charging an R-744 System.....	33
Section 3. System Checks.....	33
Section 4. Service	34
Section 5. Putting the System Temporarily Out of Service.....	37
Section 6. Maintenance.....	37
Conclusion	38
Glossary	39
List of Figures	42
List of Tables	43
List of References	43

1 Introduction

Currently it is not an easy matter for decision makers in commercial refrigeration to make a definitive choice when it comes to refrigerants and system type. For the last decade, many refrigerant options and system architectures have appeared both on paper and in practice. The sector has been in the environmental spotlight in recent years, especially as leakage studies have revealed the true effects of HFC emissions in centralized systems. Considerable reductions in emissions are certainly possible, but they do require changes.

Emerson Climate Technologies conducted a study on this topic, comparing various options. The conclusion was clear, there is no best option for key criteria like environment and power consumption. The Life Cycle Climate Performance tool is available on the Emerson website to enable customers to make tailored comparisons. Different options are likely to develop in the next decade depending on regional trends, legislation, genuine green initiatives and green image enhancement.

R-744 (CO₂) is a leading option for environmental reasons, and it can be a winner for power consumption as developments of component technology and application methods continue to reveal potential performance gains. Good experience has been gained with different system configurations over many years, particularly in central and northern Europe. The confidence resulting from this experience ensures that CO₂ will be a long-term option in the foreseeable future.

CO₂ is termed a “Natural Refrigerant” because it exists in the natural environment. Release into the atmosphere from refrigeration systems has a negligible effect compared to other CO₂ sources that are driving the global warming debate. As a refrigerant, it is a manufactured product that conforms to strict purity specifications. Its physical properties require special handling. The system pressures are much higher than in conventional systems, and all the components are designed accordingly. Today there is no difficulty in sourcing all the necessary equipment. High investment costs were characteristic of early CO₂ projects, but these costs are now on a downward trend. The refrigerant itself is a fraction of the cost of some of the specialty HFCs.

This handbook reviews the main CO₂ properties, explores the advantages of CO₂ as a refrigerant, and provides an understanding of system types and their design. This is followed by a study of optimization, operation and maintenance topics. This information will be useful to engineers responsible for designing and maintaining commercial refrigeration systems who are now encountering CO₂ systems, perhaps for the first time.



Figure 1. Copeland™ Transcritical compressor for R-744



Figure 2. Copeland™ Scroll ZO compressor for R-744

2 CO₂ Basics and Considerations as a Refrigerant

This chapter introduces carbon dioxide as a refrigerant, describes its properties and compares it to other refrigerants, both traditional and new. It outlines the hazards of CO₂ and explains why CO₂ refrigeration systems differ from conventional systems.

Section 1. Criteria for Refrigerant Selection

Various criteria like properties, safety, environmental impact, ease of use, and availability of components and expertise should be considering when selecting a refrigerant.

The following table lists the criteria that are important when selecting a refrigerant and shows how well R-744 meets these criteria. More detail is provided later in this chapter.

R-744 meets the demand for a natural refrigerant with a low global warming impact, but presents challenges in both its application and handling.

Table 1. How R-744 meets different conditions and criteria

Criteria	How well does R-744 meet the criteria?
Cooling capacity	Significantly higher volumetric capacity than conventional refrigerants
Efficiency	Efficiency depends on system type and ambient temperature
Operating conditions	Operating and standstill pressures significantly higher than for all other common retail refrigeration refrigerants
Environmental properties	Global Warming Potential (GWP) = 1, significantly lower than for commonly used HFCs
Availability of refrigerant	Varies globally but generally available
Availability of system components	Many components are different to those used on HFC retail systems, but these are now generally available
Availability of competent engineers and technicians	Varies globally but generally low; engineers must have a good understanding of basic refrigeration and good refrigeration practice and will require further training for R-744
Cost	Refrigerant cost is lower than for HFCs, but system costs are generally higher
Safety	Low toxicity and non-flammable: high-pressures and associated hazards present additional challenges
Ease of use	High-pressure and low critical point drive the need for more complex systems
Availability of appropriate standards	Safety Standards ASHRAE 15 & 34 and CSA B52-13 include R-744 ¹
Composition	Single molecule, no temperature glide in subcritical operations
Suitability as a retrofit refrigerant	Not suitable due to higher pressures

¹ ASHRAE 15 & 34 Safety Standard for Refrigeration Systems and Designation and Classification of Refrigerants
CSA B52-13 Mechanical Refrigeration Code

Section 2. Properties of R-744

Carbon dioxide is a naturally occurring substance – the atmosphere is comprised of approximately 0.04% CO₂ (400 ppm). It is produced during respiration by most living organisms and is absorbed by plants. It is also produced during many industrial processes, in particular when fossil fuels such as coal, gas or oil are burned to generate power or drive vehicles.

The triple point of carbon dioxide is high and the critical point is low compared to other refrigerants. The chart in Figure 3 shows the triple point and the critical point on a phase diagram.

The triple point occurs at 75.1 psia and -69.8°F, below this point there is no liquid phase. At atmospheric pressure (14.7 psi), solid R-744 (dry ice) sublimates directly to a gas. Solid R-744 has a surface temperature of -109.3°F. If R-744 is at a pressure higher than the triple point and it reduces to a pressure below the triple point (for example to atmospheric pressure), it will deposit directly to solid. This can occur when charging an evacuated refrigeration system with liquid R-744 for example. Solid R-744 is also known as dry ice.

The critical point occurs at 87.8°F, which is below typical system condensing temperatures for part or all of the year, depending on the climate. Above the critical point the refrigerant is a supercritical fluid. There is no phase change

when heat is removed from a supercritical fluid while it is above the critical pressure and temperature.

In a refrigeration system supercritical R-744 will not condense until the pressure has dropped below the critical pressure. No other commonly used refrigerant has such a low critical temperature so they always condense as heat is removed on the high side of the system.

The **critical point** is the condition at which the liquid and gas densities are the same. Above this point distinct liquid and gas phases do not exist.

The **triple point** is the condition at which solid, liquid and gas co-exist. The glossary has a full explanation of the terms used in this section.

The boundaries of the supercritical fluid region are:

- The critical temperature (87.8°F) to the sub-cooled liquid region
- The critical pressure (1070 psia) to the superheated gas region

Table 2 on page 7 compares the basic properties of R-744 with different refrigerants which are commonly used in the retail sector.

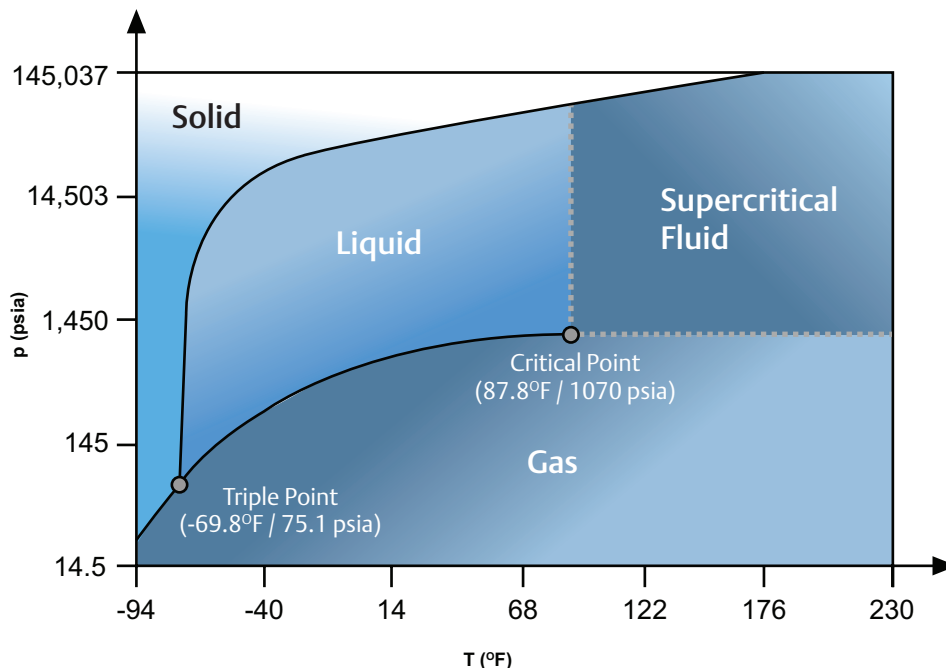

Figure 3. R-744 / CO₂ phase diagram

The pressure enthalpy chart in Figure 4 shows the critical point and the extent of the transcritical fluid region.

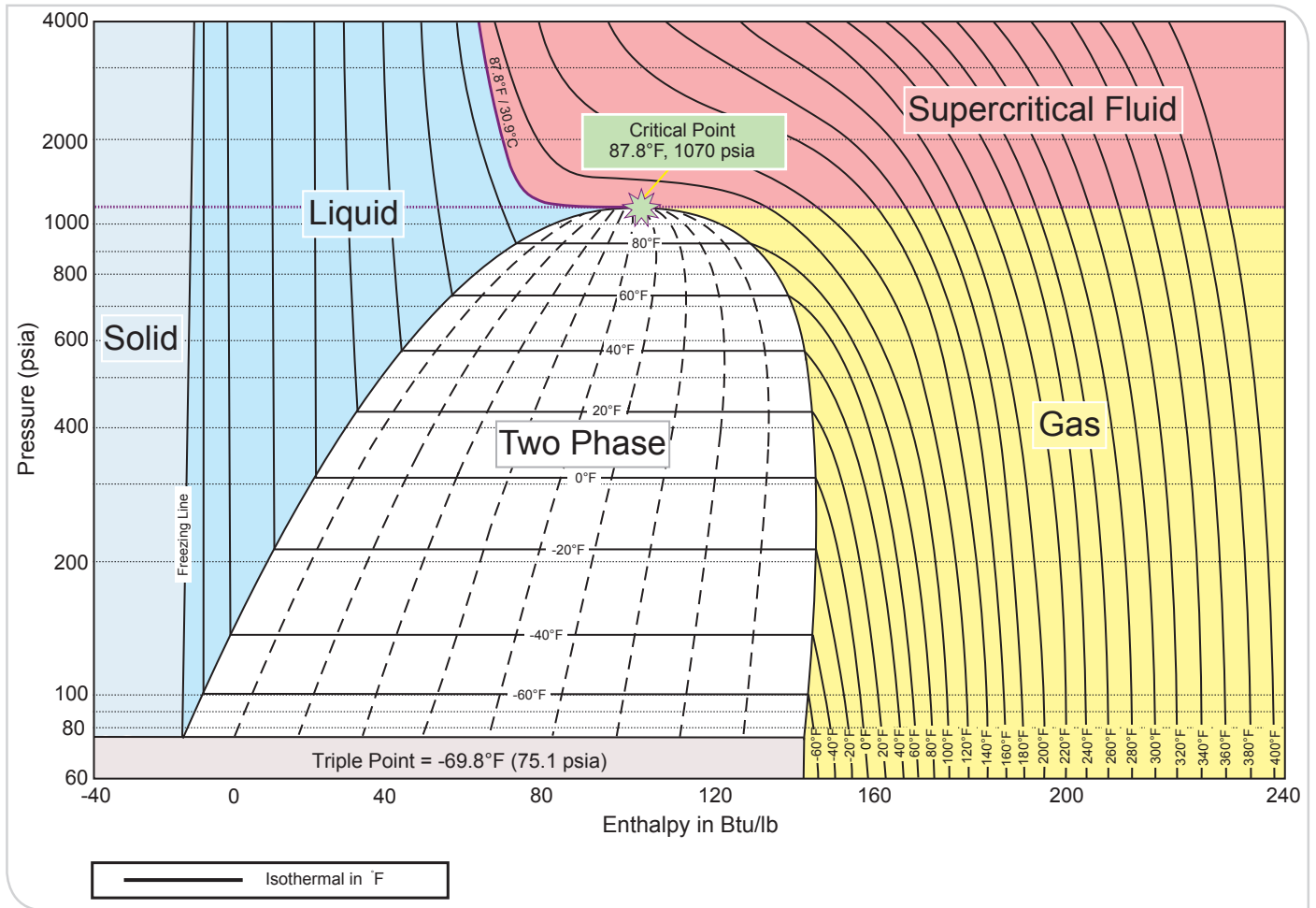

Figure 4. Pressure enthalpy chart for R-744

Table 2. Basic properties of R-744 compared with other refrigerants²

Refrigerant	Natural	HFC	HFC	HFC	HFC	HCFC	HFO
	R-744	R-404A	R-134a	R-407A	R-407F	R-22	R-1234yf
Temperature at atmospheric pressure (see information above)	-109.3°F (Temp. of the dry ice)	-50.8°F (Saturation temp.)	-14.9°F (Saturation temp.)	-41.8°F (Mid point saturation temp.)	-45.4°F (Mid point saturation temp.)	-41.8°F Saturation (temp.)	-22°C Saturation (temp.)
Critical Temperature	87.8°F	161.7°F	213.9°F	177.8°F	180.9°F	205.1°F	202.5°F
Critical Pressure	1070 psia	548 psia	588.8 psia	659 psia	688.75 psia	723.7 psia	493 psia
Triple-Point Pressure	75.1 psia	3.2 psia	0.06 psia	1.5 psia	1.5 psia	<0.073 psia	TBC
Pressure at a saturated temperature of 68°F	826.7 psia	158.1 psia	82.7 psia	136.3 psia	143.6 psia	131.9 psia	86.0 psia
Global Warming Potential	1	3922	1430	2107	1824	1790	4

²NIST REFPROP version 9.1, Manufacturer's published data

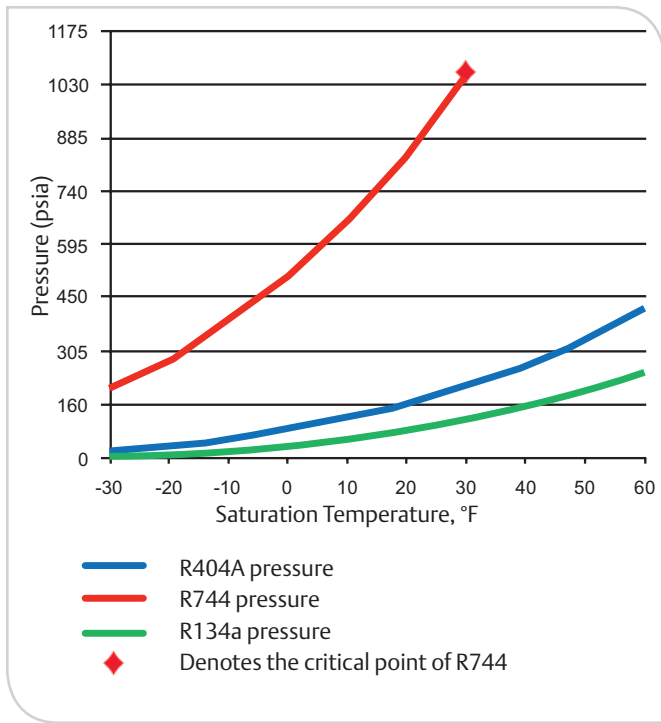

Figure 5. Pressure-temperature relationship comparison

A significant challenge with the application of CO₂ as a refrigerant is the higher operating pressures compared to other commercial refrigerants. The chart in Figure 5 compares the pressure of R-744 with R-404A and R-134a.

The saturation curve for R-744 does not extend beyond 87.8°F because this is the critical point - above this condition there is no distinction between liquid and gas. Operation above this pressure is current practice in transcritical systems.

Section 3. An Introduction to Transcritical Operation

Many R-744 systems operate above the critical point some or all of the time. This is not a problem, the system just works differently.

- R-744 systems operate subcritically when the condensing temperature is below 87.8°F
- R-744 systems operate transcritical when the “gas cooler exit temperature” is above 87.8°F and the evaporating temperature is below 87.8°F

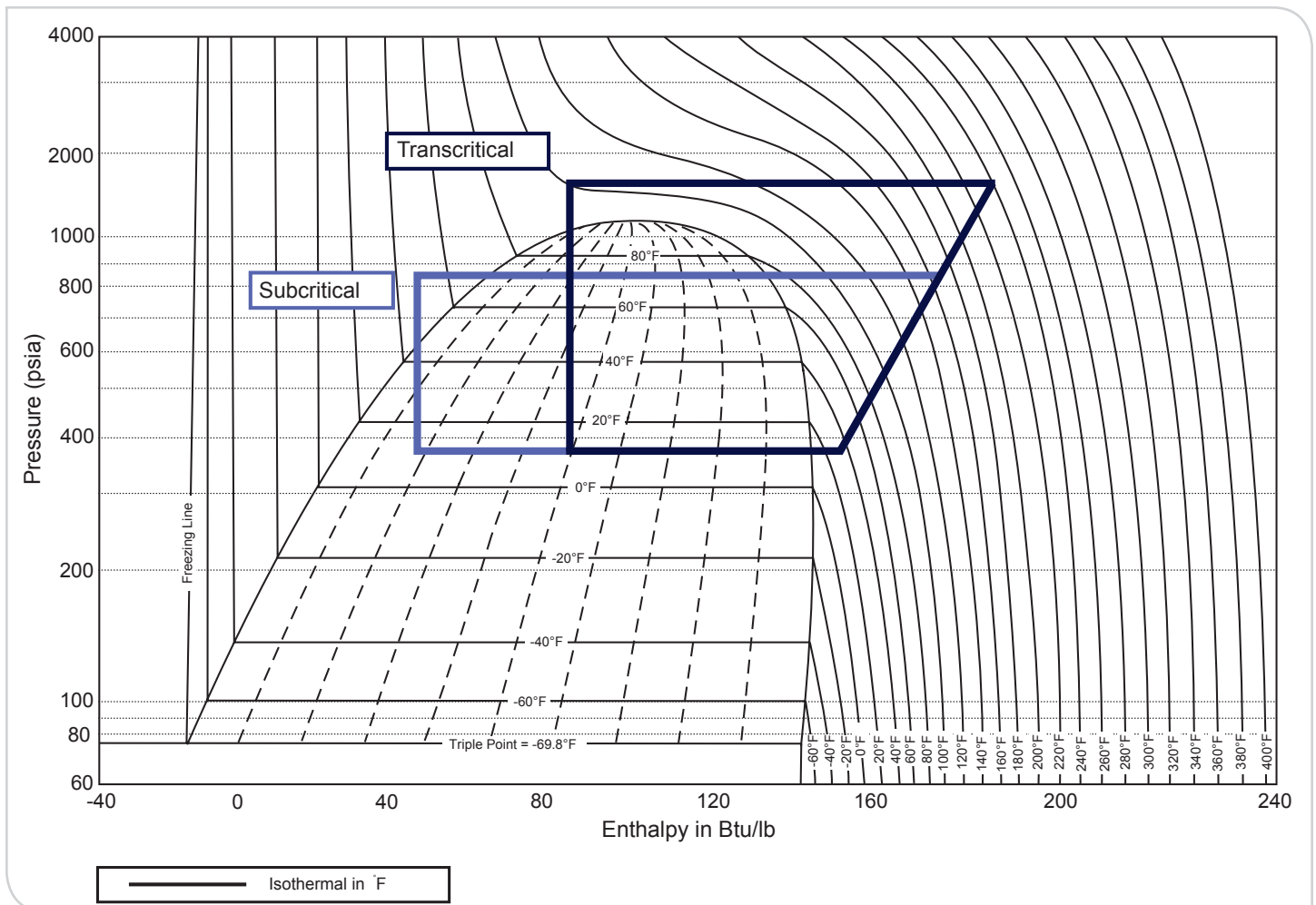

Figure 6. R-744 pressure enthalpy chart showing subcritical and transcritical systems

HFC systems always operate subcritically because the condensing temperature never exceeds the critical temperature (e.g. 214°F in the case of R-134a).

The pressure enthalpy chart in Figure 6 shows an example of a simple R-744 system operating subcritically at a low ambient temperature and transcritically at a higher ambient temperature. The chart shows that the cooling capacity at the evaporator is significantly less for transcritical operation.

A capacity drop also occurs with HFC systems when the ambient temperature increases, but the change is not as great as it is with R-744 when the change is from sub- to transcritical.

It is important that appropriate control of the high side (gas cooler) pressure is used to optimize the cooling capacity and efficiency when transcritical. For example, increasing the high side pressure will increase the cooling capacity. This is covered in more detail in Chapter 4.

Section 4. Behaviour in the Reference Cycle

Simple comparisons between R-744 and other refrigerants can be misleading because the low critical temperature of R-744 either leads to differences in system design, such as the use of cascade or transcritical systems. So like-for-like comparisons are not easy to make. A simple theoretical comparison between R-744 and common HFC refrigerants is provided below.

- R-744 compares reasonably well with HFCs when subcritical and at low condensing temperatures (e.g., the LT comparison). But at higher condensing temperatures (MT example) and when transcritical (HT example), it does not compare well.
- The high suction pressure and high gas density of R-744 results in very good evaporator performance. In like-for-like systems the evaporator temperature of an R-744 system would, in reality, be higher than for HFC systems.
- The index of compression is very high for R-744, so the discharge temperature is higher than for the HFCs. This can improve heat reclaim potential in retail systems, although the requirement for heat in the summer when the system is transcritical is limited.
- The density of R-744 results in very high volumetric capacity. This reduces the required compressor displacement (but not the motor size, which would be similar to that required for HFC refrigerants).

- The required suction pipe cross section area is in proportion to the volumetric capacity. For R-744 the diameter of the suction line is approximately half that required for R-404A.
- The compression ratio for R-744 is less than for the HFCs. This can result in higher isentropic efficiency.

Section 5. R-744 Hazards

R-744 is not flammable, but its high-pressures, toxicity at high concentration and potential for dry ice formation must be taken into account when applying and handling. This section explains some of the hazards and provides very general guidance on reducing them. More detailed information relating to the design of systems to minimize the hazards is provided later in this document.

Asphyxiation

R-744 is odourless, heavier than air and is an asphyxiate. The refrigerant concentration limit of R-744 is lower than HFCs because of its potential for high toxicity (HFCs are non toxic)³:

- Refrigerant Concentration limit of R-744: 40,000 ppm
- Refrigerant Concentration limit of R-404A: 130,000 ppm

Note – The refrigerant concentration limit is defined in ASHRAE 15 & 34 but may vary depending on regional regulations.

The table below summarises the effect of CO₂ at various concentrations in air.

Table 3. Effects of CO₂ at various concentrations in air

ppm of CO ₂	Effects
400	Concentration in atmosphere
5,000	Long-term exposure limit (8 hours)
15,000	Short-term exposure limit (10 min)
30,000	Discomfort, breathing difficulties, headache, dizziness, etc.
100,000	Loss of consciousness, death
300,000	Quick death

If a leak of R-744 could result in a concentration exceeding the practical limit in an enclosed occupied space such as a cold room, precautions must be taken to prevent asphyxiation. These include the use of permanent leak detection which activates an alarm in the event of a leak.

³ASHRAE 15 & 34 Safety Standard for Refrigeration Systems and Designation and Classification of Refrigerants

High-pressures

System components, pipe work, tools and equipment must be rated for these pressures. It should be noted that the standstill pressure on some systems (e.g. cascade systems) is higher than the maximum allowable working pressure, (MAWP), hence the pressure-relief valve setting. The pressure-relief valve will discharge in the event of a fault such as a power failure.

To ensure the pressure does not rise to the relief pressure in the event of such a fault, these systems can be fitted with a small auxiliary cooling system. This typically runs on an auxiliary (uninterruptible) power supply and will switch on when the pressure rises above a set point (this is lower than maximum allowable working pressure, but higher than the normal operating pressure). The auxiliary cooling system is sized to remove sufficient heat to keep the standstill pressure below safe low side limit when there is no load on the system (apart from heat absorbed from the ambient).

Care must be taken when charging R-744 systems. The maximum operating pressure of some systems (such as cascade systems and parts of transcritical systems) is normally below the R-744 cylinder pressure. These systems must be charged slowly and carefully to prevent pressure-relief valves discharging. Further information is given in Chapter 5.

Table 4. R-744 standstill and typical system operating pressures

Standstill at 50°F ambient	638 psig
Standstill at 86°F ambient	1031 psig
Low temp. evaporator (frozen food)	145–218 psig
High temp. evaporator (chilled food)	363–435 psig
Cascade condenser	435–508 psig
Cascade high-press. cut out (high side)	522 psig
Cascade press. -relief-valve (high side)	580 psig
Transcritical high side	1305 psig
Transcritical high-press. cut out (high side)	1566–1827 psig
Transcritical press.-relief valve (high side)	1740–2030 psig

Trapped Liquid

The coefficient of expansion for R-744 is significantly higher than for other refrigerants. The practical impact of this on liquid R-744 trapped between closed valves is shown in the graph in Figure 7:

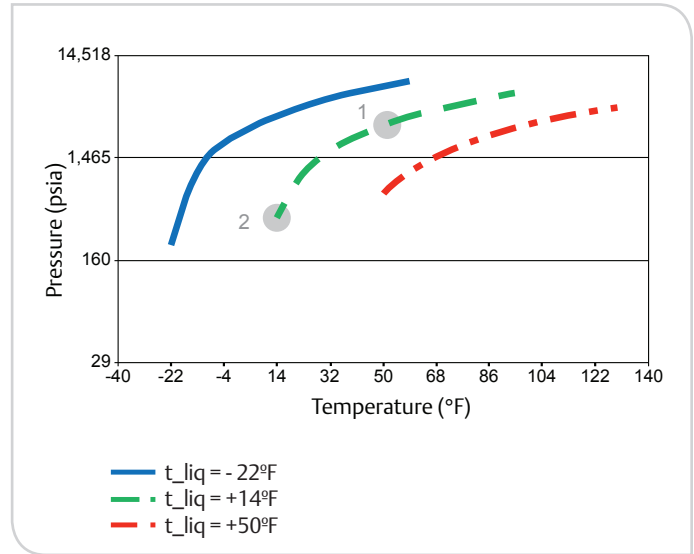

Figure 7. Relationship between temperature and pressure of trapped liquid R-744. Source: Danish Technological Institute

The example shows the effect of a 36°F temperature rise on liquid that is trapped at an initial temperature of 14°F. The pressure will increase from 638 psig to approximately 3480 psig. This condition could potentially occur in a liquid line of a cascade system, and similar situations can arise in other parts of the system and in other R-744 systems. As a rule of thumb, trapped R-744 liquid will increase in pressure by about 145 psi for every 1.8°F temperature increase.

The pressure of trapped liquid refrigerant always increases, but the pressure increase of R-744 is much greater than for other refrigerants. This is exacerbated by the potential to trap R-744 at low temperatures (LT) and hence for the liquid temperature to rise more than for other refrigerants.

Systems should be fitted with pressure-relief protection wherever liquid could be trapped, either during operation or service. Methods of providing this protection are covered in the section on design of R-744 systems.

Dry Ice

Dry ice (solid R-744) is formed when the pressure and temperature of R-744 is reduced to below the triple point (75.1 psia, -69.8°F). This will not occur within a properly working refrigeration system, but can occur when:

- A pressure-relief valve discharges if it is venting vapor R-744
- Venting R-744 during service (component change or replacement, for example)
- Charging a system which is below 75.1 psia (e.g. an evacuated system)

Dry ice does not expand when it is formed, but dry ice will become gas as it absorbs heat (e.g. from ambient). If the dry ice is trapped within the system, it will absorb heat from the surroundings and turn into gas. This will result in a significant pressure increase.

Dry ice can block vent lines, so care must be taken to ensure that this cannot occur:



- Appropriate pressure-relief valves should be used – see the section on system design for more information about these and how safety valves should be applied;
- When R-744 is vented from a system during service it should be vented as a liquid, and the pressure in the system monitored. R-744 should always be vented outside a building.

Freeze Burns

Contact with solid or liquid R-744 will cause freeze burns and should be avoided. Suitable personal protective equipment, including gloves and goggles, should always be worn when working with R-744.

Table 5. Comparison of R-744 with other refrigerants

	R-744	HFOs	HCs	R-717
Capacity	Green	Orange	Orange	Orange
Efficiency	Orange, Red	Orange	Green	Green
Pressure	Red	Orange	Orange	Orange
Environmental impact	Green	Orange	Green	Green
Flammability	Green	Red	Red	Red
Toxicity	Orange, Red	Orange	Green	Red
Availability of refrigerant	Orange, Red	Red	Green	Green
Availability of components	Orange, Red	Orange	Green	Green
Availability of expertise	Orange, Red	Red	Orange, Red	Green
Cost of refrigerant	Green	Red	Green	Green
Cost of system	Red	Orange	Orange, Red	Red

-  Refrigerant is similar to HFCs;
-  Aspect of the refrigerant is worse than HFCs;
-  Aspect of the refrigerant is better than HFCs.

HFO: Hydro Fluoro Olefin, e.g. R-1234yf

HC: Hydro Carbon, e.g. R-290

R-717: Ammonia

⁴Refrigerant Choices for Commercial Refrigeration (TGE124-0910/E) available on www.emersonclimate.eu

Section 6. Comparison of R-744 With Other Refrigerants

The table below shows a simple comparison of R-744 with other types of refrigerant, including those that are currently commonly used and those that are currently evaluated for future use. It uses a simple “traffic light” system and employs the common HFCs, such as R-404A and R-134a as a baseline.

This provides a very simple introduction to the options – the situation varies globally, especially in the availability of refrigerants, components and expertise.

For retail applications a well designed and installed R-407A/F system generally has better efficiency than R-744 systems. However, the overall environmental performance of R-744 systems is better, primarily due to the low GWP in the event of leakage. More detailed information is provided in the Emerson Climate Technologies document “Refrigerant Choices for Commercial Refrigeration”.⁴

Section 7. Advantages and Disadvantages of R-744 as a Refrigerant

R-744 has the following advantages and disadvantages as a refrigerant. The list of disadvantages appears less than the advantages, but these issues should not be overlooked as they

have a significant impact on the safety and reliability of R-744 systems. More information on the impact of the differences is highlighted below.

Table 6. Advantages and disadvantages of R-744 as a refrigerant

Advantages	Disadvantages
<p>High refrigeration capacity due to high volumetric cooling capacity (e.g., it is approximately up to 5 times that of R-404A). This has a positive impact on compressor displacement and the sizing of heat exchangers and pipe work.</p> <p>Lower pressure drops in pipe work and heat exchangers. For example, the impact of long suction and liquid lines is less.</p> <p>High heat transfer in evaporators and condensers due to the high-pressure and density. This will either allow lower temperature differences between the refrigerant and the air; therefore improving efficiency, or allow the use of smaller evaporators and condensers. Tubing wall thickness may need to be increased to handle the higher pressures, so careful design is required to take advantage of the R-744 properties.</p> <p>The pressure drop across an expansion valve is greater than with other refrigerants, so the minimum setting for head pressure control can be lower. This improves efficiency.</p> <p>Lower compression ratios leading to higher compressor isentropic efficiency.</p> <p>Non-corrosive with most materials. There are very few differences to the materials used in HFC systems.</p> <p>Good miscibility with compressor lubricants for oil return. Polyolester type lubricants can continue to be used as with HFCs.</p> <p>Low toxicity and non-flammable.</p> <p>Negligible GWP so that, in the event of a leak, the direct impact on climate change is very low.</p> <p>Inexpensive to produce and widely available, although the purity of the R-744 should be 99.99% for use in a refrigeration system with hermetic and semi-hermetic compressors, i.e., refrigerant grade.</p> <p>High discharge temperatures due to the high index of compression. This provides good potential for heat reclaim. Note – the discharge temperature is excessively high in transcritical systems with a large difference between evaporating and heat rejection temperatures.</p> <p>Stable molecule leading to a low potential for decomposition within the refrigeration system.</p> <p>There is no impending legislation phasing down or phasing out R-744 so it can be viewed as a long-term refrigerant.</p>	<p>High operating and standstill pressures are more hazardous and increase the leak potential. Specially designed components are required.</p> <p>Special compressors are required because of the higher refrigeration capacity (different motor / displacement combination).</p> <p>R-744 systems are more complex – either cascade or transcritical. This leads to higher costs in components and installation.</p> <p>Pipe working on-site potentially includes steel or stainless steel, the need for specially licensed welders, and different jointing techniques due to higher pressure and different materials.</p> <p>The greater complexity also increases the probability of poor performance and reliability, particularly if commissioning is not done well.</p> <p>For transcritical systems two stage compression is required for frozen food applications because of the high discharge temperature of R-744.</p> <p>R-744 transcritical systems are less suited for high ambient areas (e.g., Southeast Asia), where the system will always operate above the critical point, because of the inefficiency of transcritical operation.</p> <p>R-744 is not controlled by any regulation such as the European Fluorinated Gas Regulation, so its use is not as carefully monitored as HFCs and leak detection is not as rigorous. However, the high-pressures make the system leak prone, and performance will suffer if the leak rate is high.</p> <p>R-744 systems are very sensitive to water contamination and can form unusual compounds when there is a leak in a cascade heat exchanger.</p>

3 Introduction to R-744 Systems

Introduction to R-744 Systems

This chapter covers general aspects of R-744 systems. More detail about transcritical and cascade systems and components is given in Chapter 4.

The properties of R-744 effect how the refrigerant is applied (see Chapter 2 for more information):

- The high density of R-744 compared to HFCs results in the requirement for less compressor displacement. However the motor size would be similar since the work done is approximately the same. Smaller pipe diameters are also a result of the higher density, especially on the suction side of the system.
- The higher pressures of R-744 result in the need for all components to have a higher maximum pressure rating.
- The high discharge temperatures of R-744 (because of the high index of compression) result in the need for two-stage compression for LT systems that reject heat to ambient air.
- The low critical temperature of R-744 results in differences in system design and control. In the retail sector this results in R-744 being used mainly in the following types of system:

> **Transcritical systems:** Systems are called transcritical when heat rejection takes place above the critical point of the refrigerant (for CO₂ ambient temperatures from 68°F to 77°F). (See Figure 8)

> **Booster systems:** Systems with two temperature levels (e.g., -31°F and -4°F evaporating temperature) and with low-stage and medium stage compressors (see Figure 11).

> **Cascade systems:** R-744 is the low-stage refrigerant in a cascade system in which the R-744 is always subcritical. The heat rejected by the condensing R-744 is absorbed by the evaporating high-stage refrigerant. The high-stage system is usually a conventional system using HFC or HC, in which case this is **termed hybrid cascade**. In some systems R-744 is used in the high-stage as well as the low-stage. The R-744 in the low-stage is always subcritical, but in the high-stage will be transcritical at high ambient conditions.

> **Secondary systems:** R-744 is used as a secondary volatile fluid and is pumped through the heat exchangers (cooling load). The CO₂ is not completely evaporated, the gas is condensed by a chiller.

The next three sections introduce transcritical, cascade and secondary systems and explain how each system works. The advantages and disadvantages of each are summarised and compared after these two sections. There is more detail about the individual components and their selection in Chapter 4.

Section 1. Introduction to Retail Transcritical Systems

The diagram in Figure 8 is a simple, single stage transcritical system. The refrigerant discharged from the compressor flows into the gas cooler where heat is removed and the refrigerant temperature becomes cooler. The refrigerant is above the critical point, so it does not condense in this part of the system. The refrigerant then passes through

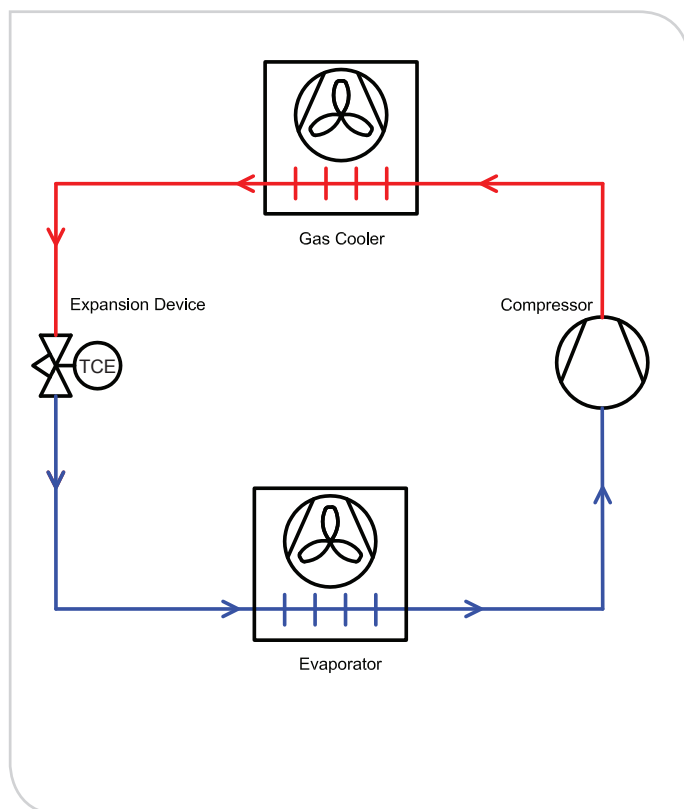

Figure 8. Simple transcritical system for medium temperature

the expansion device. The refrigerant condenses when its pressure drops below the critical point. Vapor then forms as the pressure reduces further to the evaporating pressure. The saturated refrigerant then flows into the evaporator where it evaporates and superheats as usual. The superheated gas is drawn back into the compressor.

In this simple system:

- The temperature of the refrigerant at the exit of the gas cooler depends on the size of the gas cooler
- The pressure of the refrigerant in the gas cooler depends on the quantity of refrigerant in the system and the ambient temperature

The disadvantage of this type of system is that its capacity and efficiency vary significantly with ambient (air in) temperature and with the quantity of refrigerant in the system. The simple transcritical system is shown on a pressure enthalpy chart in Figure 9.

Three example systems are shown on the pressure enthalpy chart. They each have identical evaporating conditions.

In a transcritical system the R-744 discharges from the compressor as a supercritical fluid because its pressure and temperature are above the critical point. In a subcritical system the refrigerant would de-superheat and then condense, rejecting heat at a constant temperature as it condenses. In a transcritical system the refrigerant does not condense – it rejects heat as a transcritical fluid and its temperature reduces during this process. (Even with a wide temperature-glide HFC such as R-407A, the temperature change through the condenser is small compared to that of a gas cooler in a transcritical system.)

In each example above, the R-744 exits the gas cooler at a temperature of 104°F. This exit temperature is a function of the size of the gas cooler and the ambient temperature, in the same way as condensing temperature is a function of the size of the condenser and the ambient temperature.

The cooling capacity of each system above varies significantly. For pressures below approximately 4350 psig the cooling capacity reduces as the pressure reduces. This is the opposite of what happens in a subcritical system where cooling capacity is greater at lower discharge pressures.

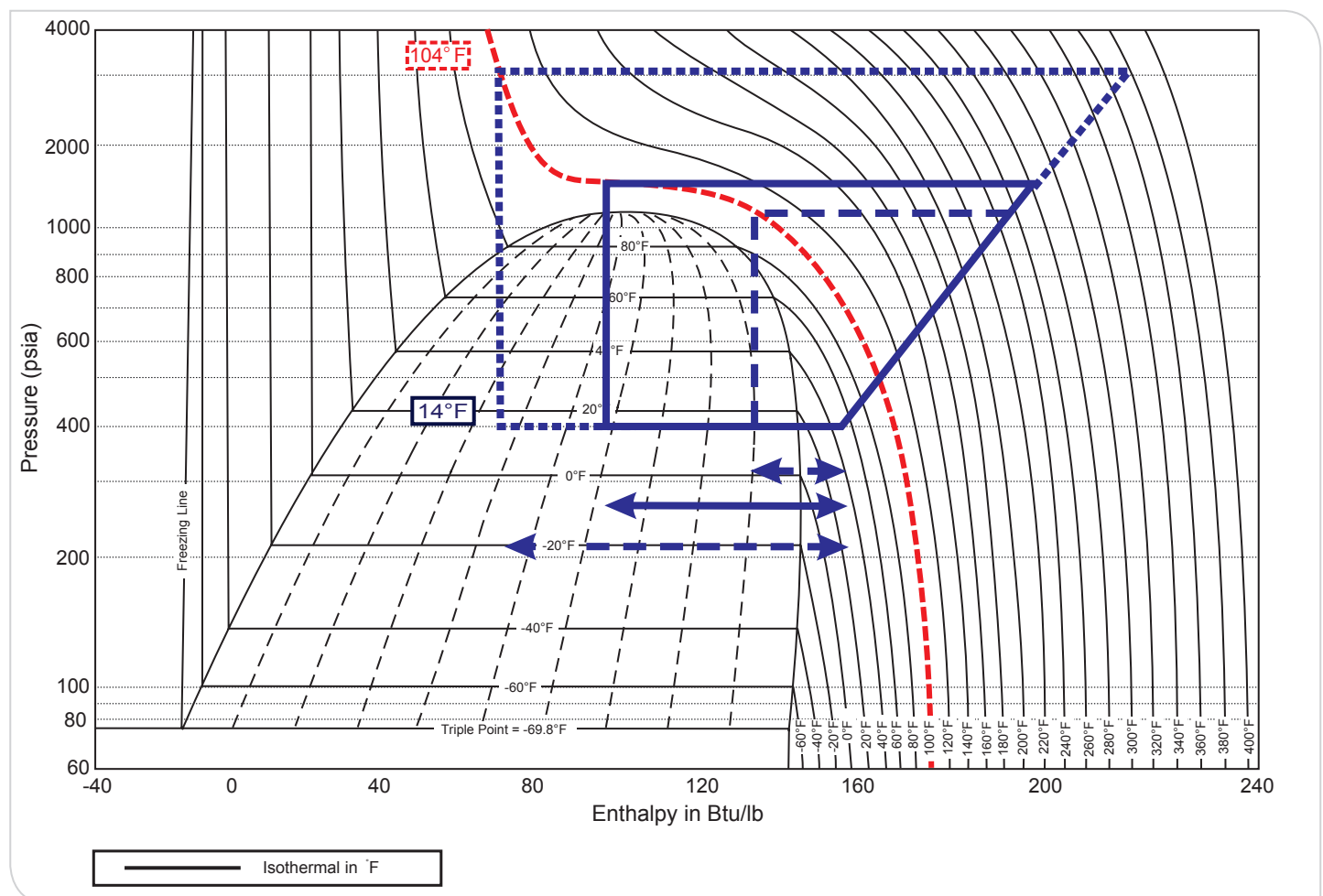

Figure 9. Pressure enthalpy chart showing transcritical operation

The compressor power input of each system also varies – the lower the pressure the lower the power input. This is the same as for a subcritical system.

The pressure enthalpy chart shows that the variation in power input is not proportional to the variation in cooling capacity. For example, increasing the head pressure from condition 1 to condition 2 provides a significant increase in cooling capacity with a very low increase in compressor power input. Increasing the pressure from condition 2 to condition 3 gives an increase in cooling capacity that is less than the increase in compressor power input.

The coefficient of performance (COP) varies widely. Unlike subcritical systems the maximum COP does not occur when the condensing pressure is at a minimum. The optimum COP depends on the evaporating conditions and gas cooler exit temperature, but is typically at a pressure between 1305 psig and 1450 psig. In general the pressure for optimum capacity is greater than that for optimum COP.

In a retail transcritical system the gas cooler pressure is controlled to provide either optimum capacity or optimum efficiency while maintaining the pressure below the maximum allowed at all times. The simple diagram in Figure 10 shows how this pressure is controlled in a typical retail system with single stage compression.

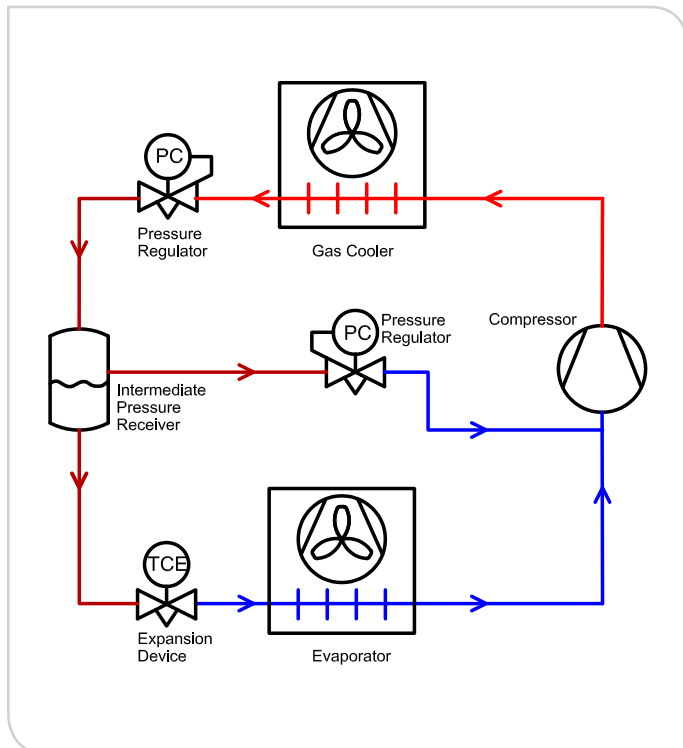

Figure 10. Typical retail system with single stage

The two additional valves in this simple system control the gas cooler and intermediate pressures:

- The gas cooler pressure valve 1 (also called the high-pressure regulating valve) controls the pressure in the gas cooler. It is a pressure-reducing valve which is controlled from the R-744 pressure in the gas cooler and its exit temperature.
- The receiver pressure valve 2 (also called the medium pressure regulating valve or the flash gas valve) controls the pressure of the refrigerant in the receiver and associated liquid distribution pipe work. It is controlled from the pressure in the receiver. Note that this receiver is also called a flash tank.

The gas cooler pressure is usually selected for optimum COP as described above, unless greater capacity is required, in which case a higher pressure would be selected to provide this while required.

Subcritical Operation

The ambient temperature profile will determine the proportion of time a system runs in transcritical mode. For many regions a proportion of the operation will be subcritical, typically when the ambient temperature is below 68°F to 77°F. In this case the gas cooler pressure valve usually controls the refrigerant in the condenser such that it exits the condenser with a specified degree of sub cooling.

Retail Booster Systems

Two-stage compression is used for transcritical low temperature applications because the discharge temperature of R-744 is high and will potentially result in lubricant break down. The diagram in Figure 11 shows a simple two stage booster or externally compounded system.

The refrigerant from the low temperature loads is drawn into the low-stage compressors. The discharge from these compressors goes into the suction of the high-stage compressors.

The refrigerant from the medium temperature (MT) loads is drawn into the suction of the high-stage compressors. The refrigerant from the receiver pressure regulating valve is also drawn into the suction of the high-stage compressors. The flash gas from the receiver pressure regulating valve, and the suction gas from the medium temperature loads provide some interstage cooling. This is usually enough

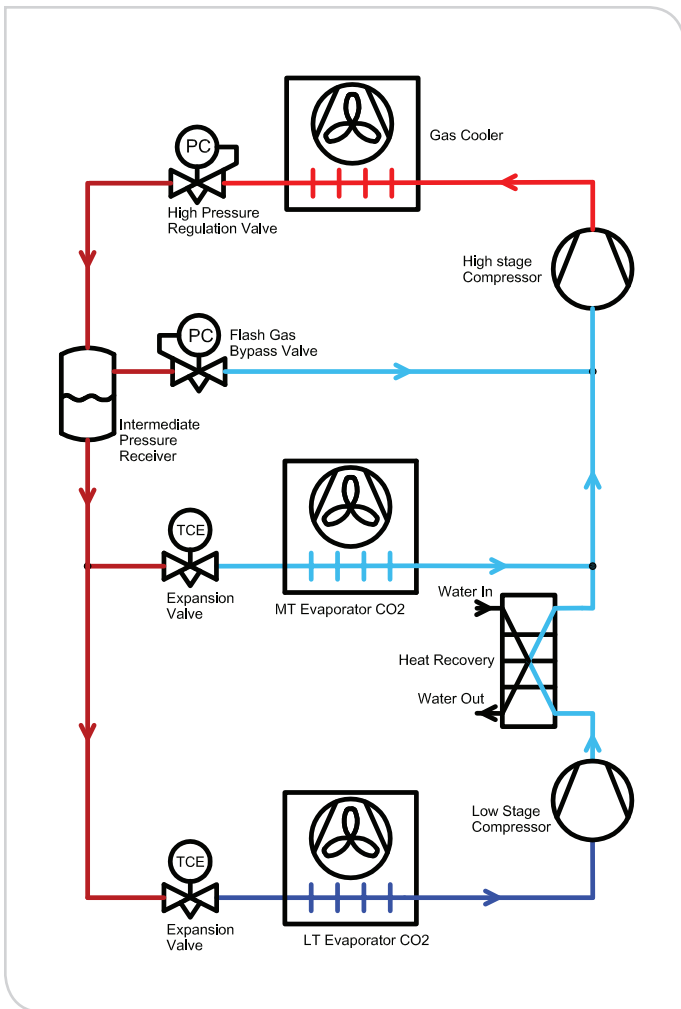

Figure 11. Simple booster system without oil management

to maintain the discharge temperature of the high-stage compressors below the level at which the lubricant will deteriorate. Additional interstage cooling can also be provided if required.

Section 2. Introduction to Retail Cascade Systems

The cascade system comprises:

- The low-stage, which provides the cooling for the load. It uses R-744 and is always subcritical
- The high-stage, which absorbs the heat from the condensing R-744 at the cascade heat exchanger

Within the cascade heat exchanger the evaporating high-stage refrigerant absorbs the heat rejected by the condensing R-744. The R-744 condensing temperature is maintained below the critical point. The high-stage is usually a simple, close coupled system. It is controlled by the pressure in the low-stage receiver.

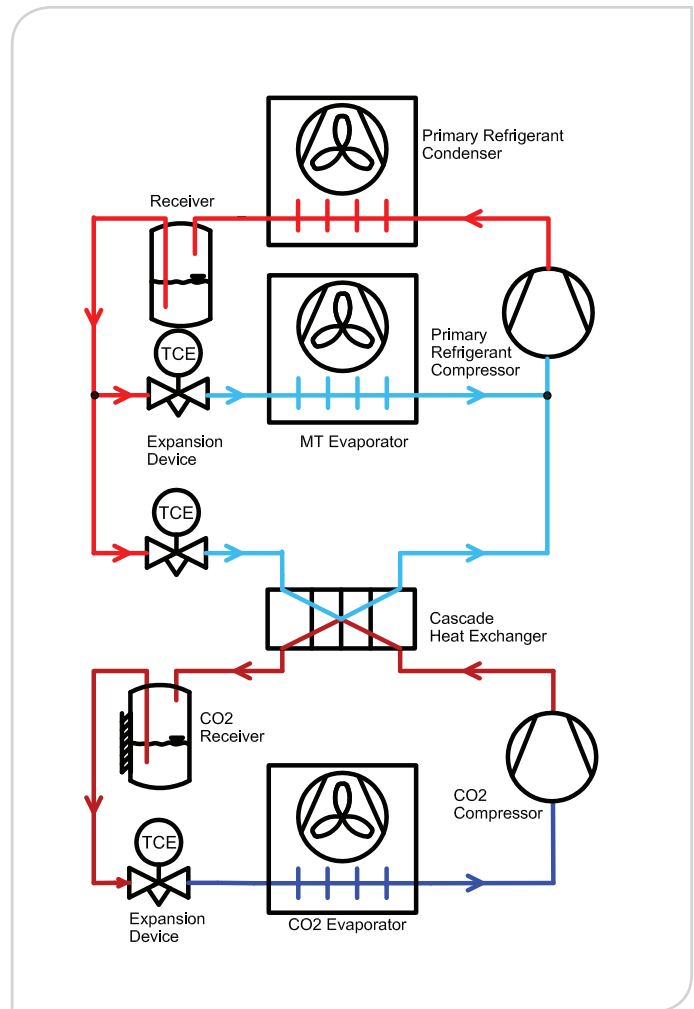

Figure 12. Simple cascade system

In this case the high-stage provides cooling for the medium temperature load as well as removing the heat from the condensing R-744 in the low-stage at the cascade heat exchanger. The high-stage refrigerant is usually an HFC or HC, in which case the cascade is a hybrid system. In some systems R-744 is used in the high-stage. It will be transcritical at ambient temperatures above 68°F to 77°F – see Section 1 for more information about this.

Section 3. Secondary Systems

The diagram in Figure 13 shows a simple secondary system. The high-stage system cools the liquid R-744 in the secondary circuit. The R-744 is pumped around the load. It is volatile, so unlike a conventional secondary fluid such as glycol it does not remain as a liquid, instead it partially evaporates. It therefore has a significantly greater cooling capacity than other secondary fluids. This reduces the pump power required and the temperature difference needed at the heat exchanger. The R-744 would typically be cooled to 26.6°F for the MT load, and to -13°F for the LT load.

The high-stage system is a simple chiller type system, typically running on an HFC or HC refrigerant.

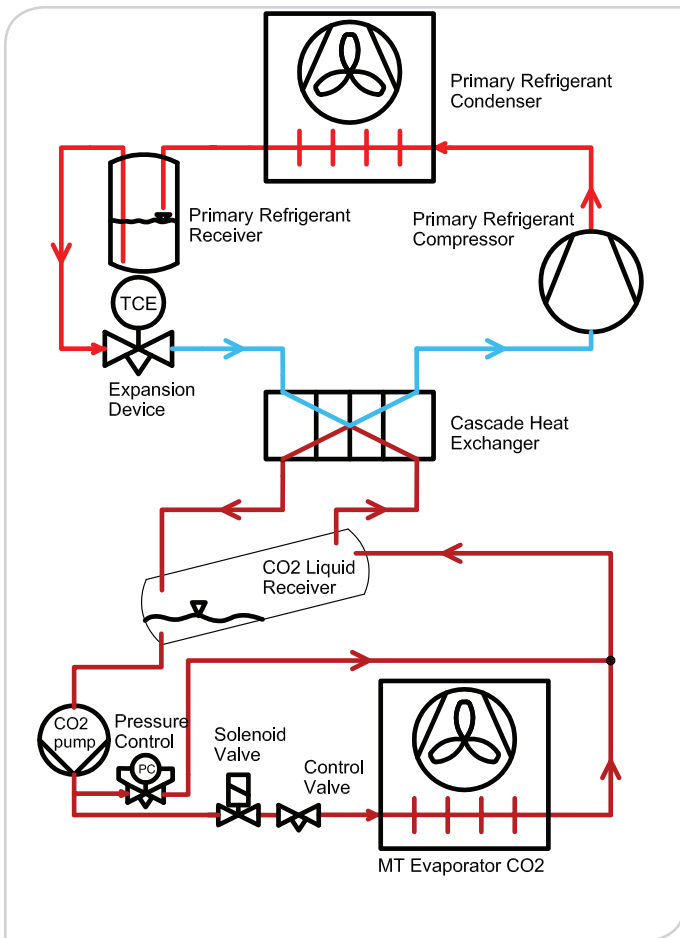

Figure 13. Simple pump system secondary

Section 4. Selecting the Best System – Booster Versus Cascade Versus Secondary

Table 7. Advantages and disadvantages of cascade and transcritical retail systems

System	Advantages	Disadvantages
Transcritical Booster	<ul style="list-style-type: none"> • One refrigerant • One system, lowest system costs • Better efficiency than HFC systems in mild climates 	<ul style="list-style-type: none"> • LT applications require two-stage compression • System faults in coupled systems affect MT and LT • High operation pressures • Lower efficiency as HFC systems in warm climates
Cascade	<ul style="list-style-type: none"> • Two simple systems • LT with low R-744, the MT with a low GWP HFC refrigerant • Standard HFC components for medium and low temperature cycles • Better efficiency in warm climates 	<ul style="list-style-type: none"> • Two refrigerants although R-744 can be used in the high stage • Temperature difference in the cascade heat exchanger reduce the efficiency slightly for the LT cycle • System faults in coupled systems affect MT and LT
Secondary	<ul style="list-style-type: none"> • Using R-744 as a secondary fluid using the latent heat, very low pump power required • Simple chiller system for the high -stage with readily available components (separate chiller for LT and MT) • System works at constant pressure without any pressure pulsation • Option to combine LT and MT, pump circulation system for the MT using R-744 combined with a LT booster system • Chiller could use low GWP HFCs or HCs 	<ul style="list-style-type: none"> • Additional heat exchange and temperature difference slightly reduce the efficiency • R-744 pumps required • Pumps in this size are not readily available and are unfamiliar to many refrigeration engineers

The information in Figures 14 and 15 are examples of comparisons between typical retail cascade, transcritical booster and secondary systems of the same cooling capacity⁵. In both examples the MT cooling load is 900,000 BTU's and the LT load is 300,000 BTU's:

- Base case is a centralized DX system that uses R-404A as the refrigerant for MT and LT

- Case 1 is a hybrid cascade system that uses R-744 as the low-stage refrigerant and R-134a as the high-stage refrigerant
- Case 2 is a transcritical booster system that uses R-744 as the MT and LT refrigerant

The system conditions and leak rates used for the analysis are provided in the tables of Figure 16.

⁵Life Cycle Climate Performance Calculator using default conditions

Life Cycle Climate Performance Analysis

Rochester, New York

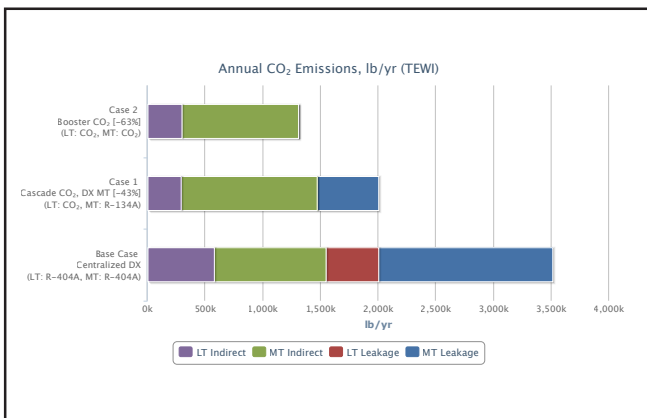
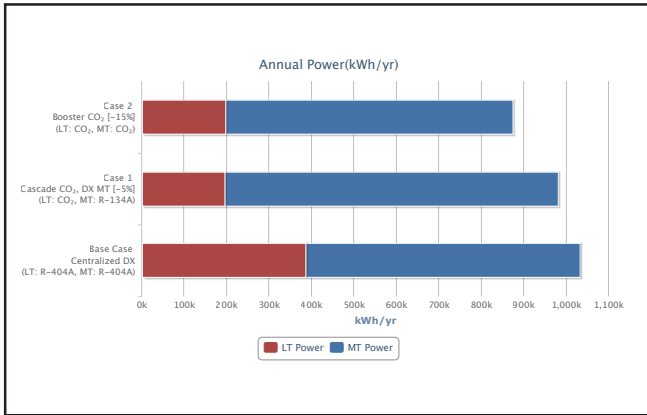

Figure 14. Comparison of system types, Rochester, NY

Atlanta, Georgia

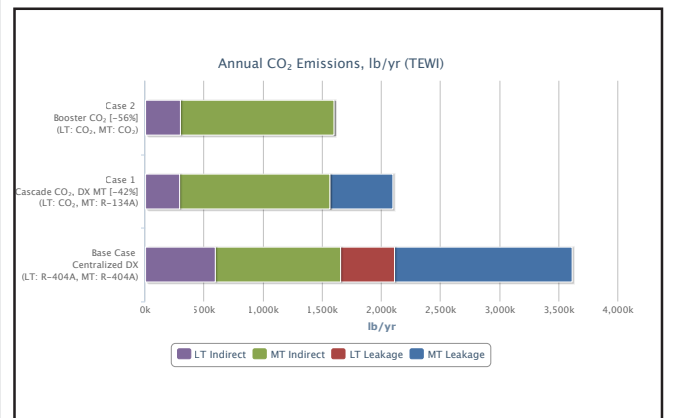
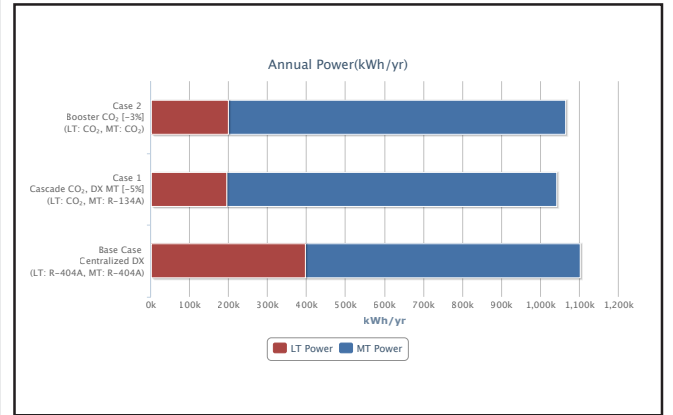

Figure 15. Comparison of system types, Atlanta, GA

ENGINEERING UNITS: I-P (ENGLISH)

CASE VARIABLES

Low Temp. Load (Btu/hr)	300,000
Medium Temp. Load (Bth/hr)	900,000
Country	USA

BASE CASE

System	Centralized DX
Low Temp. Refrigerant	R-404A
Medium Temp. Refrigerant	R-404A

CASE 1

System	Cascade CO ₂
Low Temp. Refrigerant	CO ₂
Medium Temp. Refrigerant	R-134A

CASE 2

System	Booster CO ₂
Low Temp. Refrigerant	CO ₂
Medium Temp. Refrigerant	CO ₂

Base Case (Centralized DX System)	Case 1 (Cascade CO ₂ System)	Case 2 (Booster CO ₂ System)
LT	LT	LT
-25°F SST	-25°F SST	-25°F SST
10°F Condensor ΔT	8°F Condensor ΔT	36°F Compressor Superheat
70°F Minimum Cond. Temp.	26°F Minimum Cond. Temp	0°F Subcooling
40°F Compressor Return Gas	36°F Compressor Superheat	10°F Evaporator Superheat
50°F Liquid Temp	0°F Subcooling	135 lb. Refrigerant Charge
10°F Evaporator Superheat	10°F Evaporator Superheat	15% Leak Rate
775 lb. Refrigerant Charge	400 lb. Refrigerant Charge	
15% Leak Rate	15% Leak Rate	
10% Cond. Fan Power		
MT	MT	MT
20°F SST	20°F SST	20°F SST
15°F Condensor ΔT	15°F Condensor ΔT	50°F Minimum Cond. Temp.
70°F Minimum Cond. Temp.	70°F Minimum Cond. Temp.	20°F Compressor Superheat
50°F Compressor Return Gas	50°F Compressor Return Gas	0°F Subcooling
0°F Subcooling	0°F Subcooling	10°F Evaporator Superheat
10°F Evaporator Superheat	10°F Evap. Superheat	405 lb. Refrigerant Charge
2560 lb. Refrigerant Charge	2500 lb. Refrig. Charge	15% Leak Rate
15% Leak Rate	15% Leak Rate	6% Cond. Fan Power
10% Cond. Fan Power,	10% Cond. Fan Power	1.2 Electric Generation Factor (lb/kWh),
1.2 Electric Generation Factor (lb/kWh)	1.2 Electric Generation Factor (lb/kWh)	10°F Condenser Subcritical ΔT
		5°F Condenser Transcritical ΔT
		0°F Non Useful Superheat
		100°F Gas Cooler Outlet Temp.
		580 psig Flash Tank Pressure

Figure 16. Variables used in system comparison calculations

Based on the LCCP calculations above, the Booster CO₂ system, when compared to the centralized R-404A DX system, consumes 15% less annual energy when located in Rochester, NY and 3% less in Atlanta, GA.

When analyzing the Total Equivalent Warming Impact (TEWI), the Booster CO₂ system showed a significant reduction in annual CO₂ emissions when compared to the centralized R-404A DX system. Removing the higher Global Warming Potential (GWP) HFC refrigerant from the system resulted in reduction of annual emissions by 63% in Rochester, NY and 56% in Atlanta, GA.

CO₂ system architecture is generally driven by the ambient temperature profile:

- Because the efficiency of transcritical operation is greatly affected by ambient temperature, these systems are normally used in areas where the ambient temperature is generally low (i.e., predominantly below

68°F to 77°F), such as northern Europe and Canada. Using additional technology like adiabatic gas coolers, parallel compression, ejectors and sub-cooling can bring significant improvements to efficiency, especially in warmer climates.

- In locations like Southern Europe, the U.S., much of Central and South America, Southeast Asia, Africa and Australia where the ambient temperature is higher, cascade and secondary systems (subcritical R-744) may be preferred. Because HFC refrigerant charges are reduced, both of systems offer a reduction in annual CO₂ emissions.

4 R-744 Systems Design

Introduction

This chapter includes more detailed information about the design of R-744 cascade, transcritical booster and secondary systems. For detailed application information about Emerson R-744 components refer to the Emerson document “System Product Offering”.

Section 1. Transcritical Booster Systems

The main components of a transcritical booster system are listed in Table 8 and are shown in the diagram in Figure 18. The reference column in Table 8 shows the reference to the component in Figure 18.

Intermediate Pressure

The intermediate pressure is selected based on the following (conflicting) requirements:

- The requirement for as low a pressure as feasible on the shop floor
- The requirement for the maximum allowable pressure of the pipe work to be above the pressure equivalent to maximum ambient if the plant is at standstill (see section 4 for more information on standstill-pressure)

The pressure enthalpy chart in Figure 17 show both intermediate pressures in systems with the same evaporating and gas cooler conditions.

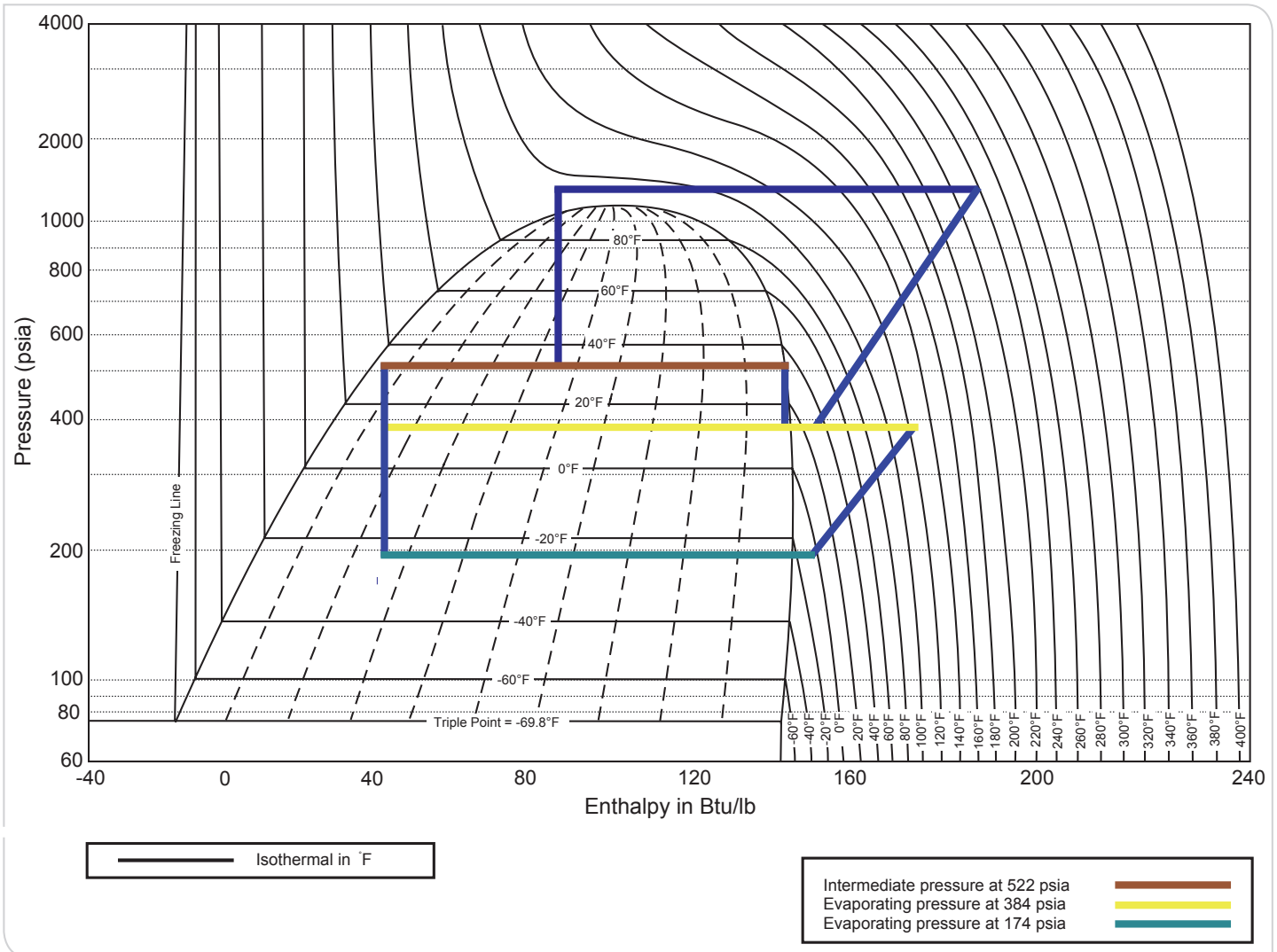

Figure 17. Pressure enthalpy chart showing two interstage conditions

Table 8. Reference table to what is shown in Figure 18:

Component	Type	Ref
Low-stage compressor	Compressors that are rated for R-744 are used	1
High-stage compressor	Compressors specifically designed for transcritical R-744 must be used. These are usually semi-hermetic reciprocating compressors	2
Oil separator and oil return system	The oil separator and reservoir work on the same principles as a conventional oil management system (e.g., coalescent type oil separation), designed for the higher operating pressures	3
Gas cooler / condenser	Typically air-cooled, multi-fan, finned-tube type	4
Gas cooler regulating valve	A pressure-modulating valve is used, controlled from the pressure and exit temperature of the gas cooler	5
Liquid receiver (flash tank)	Standard design rated for the higher pressure	6
Receiver pressure regulating valve	A pressure modulating valve is used, controlled from the pressure in the liquid receiver (flash tank)	7
Expansion device	Electronic expansion valves are used. R-410-rated valves can be used for systems with lower interstage pressure	8
Evaporator	Typically smaller diameter pipe and fewer passes are used, rated for the higher pressure	9
Others	<ul style="list-style-type: none"> Pressure-relief valve: High-lift types are used to prevent blockage with dry ice, with a discharge pressure rated for R-744 Filter drier: Molecular sieve type suitable for the pressures, R-410A-rated filter drier can be used for systems with lower intermediate pressure Switches: High-pressure and low-pressure cut-outs rated for the pressure are used 	

Table 9. Advantages & disadvantages of two typical intermediate pressures

Intermediate Pressure	Advantages	Disadvantages
507 psig (33.8°F sat temp.)	<ul style="list-style-type: none"> Lower hazard in the event of a leak Lower potential for leakage Lower cost of components and pipe work Components and pipe work are more readily available 	<ul style="list-style-type: none"> High potential for flash gas at the expansion valves due to low liquid temperature (i.e., sub-cooling does not occur naturally in the liquid line) Standstill pressure is above MAWP so PRVs will discharge in the event of a fault
870 psig (73.4°F sat temp.)	<ul style="list-style-type: none"> Standstill pressure is below MAWP for most ambients/ store temperatures. Low potential for flash gas formation because the liquid temperature should be above store temperature 	<ul style="list-style-type: none"> Higher potential for leakage Greater potential hazard in the event of a leak Higher cost of pipe work and components

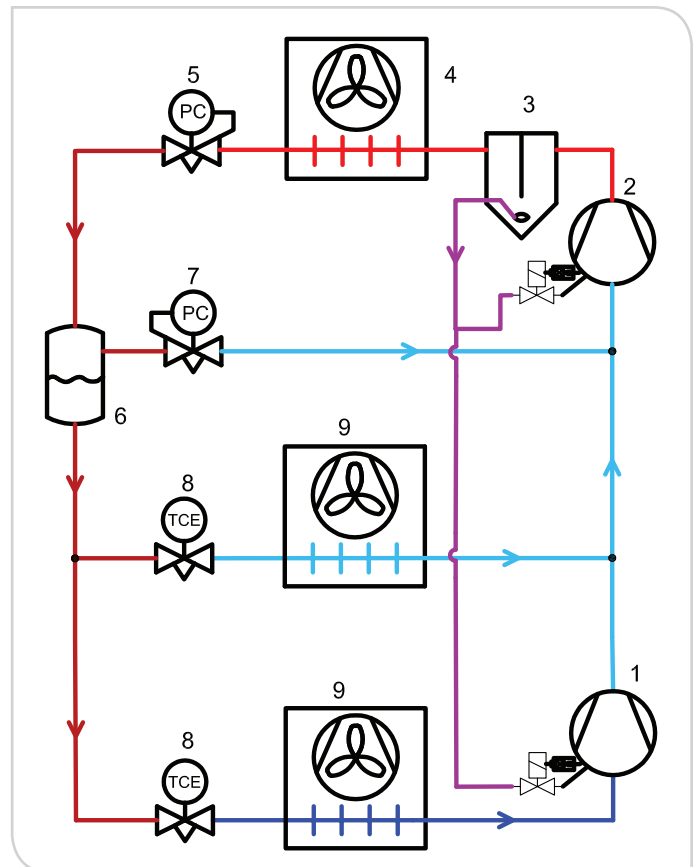

Figure 18. Typical retail transcritical booster system

There is little difference in efficiency of the two intermediate conditions because the increased enthalpy difference with the lower intermediate pressure is offset by the greater amount of flash gas produced by the increased pressure drop across the gas cooler regulating valve.

Pipe Work Temperature

It is important to consider that with the low intermediate pressure the liquid line is below ambient temperature so there is no natural liquid subcooling. Unless there is a mechanical subcooler, the refrigerant entering the expansion valve is not subcooled, but will potentially contain flash gas. To account for this the electronic expansion valve is oversized, often by as much as 30%.

If the liquid line is below ambient temperature for most of the time it should be insulated to reduce non-useful heat gain and to prevent condensation in humid climates.

Start up and Operation

The high-stage compressor(s) must be installed and running before the low-stage compressors can be started.

Section 2. Cascade Systems

The R-744 in the low-stage of a cascade system is designed to be subcritical during operation.

The main components of the low-stage of a cascade system are listed in the Table 11 and are shown in the diagram in Figure 19. The reference column in the table shows the reference to the component in Figure 19.

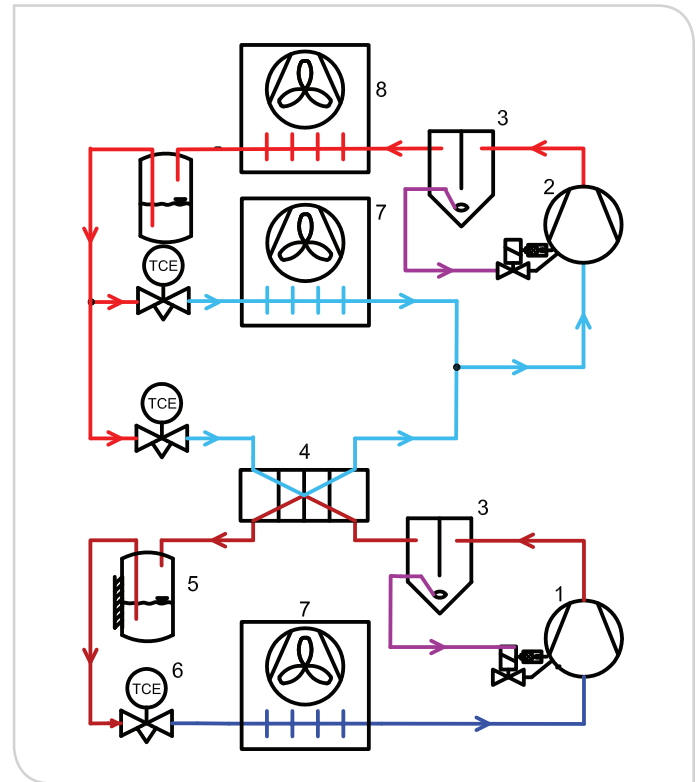

Figure 19. Typical retail cascade system

Table 10. Reference table to what is shown in Figure 19

Component	Type	Ref
Low-stage compressor	Compressors that are suitable for R-744 are used for low temperature	1
High-stage compressor	Compressors that are suitable for HFC/HC/Ammonia are used for medium temperature	2
Oil separator and oil return system	Components rated for R-410A pressures can be used*	3
Cascade heat exchanger	Typically a plate heat exchanger or shell and tube rated for R410A *	4
Liquid receiver	Receiver rated for R-410A pressures can be used *	5
Expansion device, typically EEV	Electronic Expansion Valves (EEV) are normally used, rated for R-410A pressures*	6
Evaporator	Evaporators rated for R-410A pressures can be used	7
Gas Cooler	Typically air-cooled, multi-fan, finned- tube type	8
Others	<ul style="list-style-type: none"> De-superheater: Typically a plate heat exchanger Pressure-relief valve: Valves rated for R-410A relief pressures can be used* Filter drier: Filter drier rated for R4-10A pressures can be used* Molecular sieve types are usually used Switches: High-pressure and low-pressure cut-outs rated for R-410A pressures can be used* 	

*If the high side MAWP is above 580 psig, R-410A components are not suitable, so R-744 rated components are used.

Pipe Work Temperature

Most of the R-744 pipe work is below 23°F and is therefore insulated to minimize heat gain into the refrigerant. Only the discharge line between the compressor and the cascade heat exchanger is not insulated. All the components with the exception of the R-744 compressors are also insulated to reduce heat gain into the refrigerant.

The R-744 liquid temperature is usually below the temperature of the surrounding ambient, so it does not subcool as it flows along the liquid line. Unless there is a mechanical sub-cooler, the refrigerant entering the expansion device at the LT load will be saturated, reducing the cooling capacity of the evaporator. The expansion device is sized to take account of the lack of subcooling – typically it will be 30% greater capacity than standard.

The Cascade Heat Exchanger

The cascade heat exchanger (R-744 condenser) is typically either a plate or a shell- and tube-type heat exchanger. The greater its capacity the lower the temperature difference between the condensing R-744 and the evaporating high-stage refrigerant. This will result in better efficiency of the total system.

The cascade condenser must be located above the liquid receiver to ensure the liquid R-744 flows into the receiver and does not back up in the condenser.

The R-744 discharge temperature is usually high, leading to a wide temperature difference between the superheated R-744 entering the cascade heat exchanger and the high-stage refrigerant leaving it. The high Delta T can cause thermal stress and unstable operation especially in plate heat exchangers. It is beneficial to reduce the discharge line temperature of the R-744 entering the cascade heat exchanger.

This can be achieved by using a de-superheater between the discharge of the R-744 compressor(s) and the cascade heat exchanger. The heat reclaimed can be used, for example, for heating water. This has the added advantage of reducing the amount of heat that must be rejected at the cascade heat exchanger.

Selection of Low-Stage Maximum Pressure (MAWP)

The standstill pressure of the low-stage of the cascade is usually higher than the operating pressures of both the low- and high-pressure sides of this part of the system. For example, the high side operating pressure is typically in the range 363 psig to 493 psig. In an ambient temperature of 68°F, and if the high-stage system is not operating, the

R-744 stand-still pressure will rise to 812 psig. This will not occur immediately because the insulation on the pipe work and components reduces the heat gain from ambient. If the maximum allowable working pressure (MAWP) for the R-744 system is selected to be below the potential maximum standstill pressure, the pressure-relief valves (PRVs) will discharge R-744 if the high-stage is not operating, unless the system is designed to avoid this.

PRV discharge should be avoided where possible to reduce the associated hazard and service costs and to avoid consequential loss. It will also avoid deterioration of the PRV which can lead to leakage from the valve if it does not reseat correctly after discharge. The spring can also weaken resulting in a lower relief pressure.

For cascade systems, MAWP (and hence the pressure-relief valve setting) is typically 653 psig. If the high-stage system fails or in the event of a power failure, pressure-relief valve discharge can be avoided by:

- The use of a small auxiliary condensing unit connected to an uninterruptable power supply, that removes heat from the R-744 liquid receiver. Such a system will remove the heat gain from ambient into the R-744 and will therefore be sufficient if the high-stage is inoperable due to power failure (in which case there will be no main heat load on the system from the evaporators). The auxiliary condensing unit will not be sufficient to maintain the low-stage system below MAWP if there is a load from the evaporators.
- The use of a separate pressure-relief system. This is typically a solenoid valve or ball valve that opens and relieves R-744 to atmosphere at a pressure below MAWP but above the maximum condensing pressure. This can be achieved by the use of a transducer or high-pressure switch that opens a solenoid valve or motorised ball valve to discharge R-744. The pressure does not reach MAWP and hence the pressure-relief valve(s) do not discharge. This does not prevent the discharge of R-744, but it does reduce the probability of the pressure-relief valves venting with the associated high loss of refrigerant and potential requirement to replace the relief valves. The transducer and motorised ball valve can be run from an uninterruptable power supply so they still function in the event of a main power cut.

If MAWP for the low-stage system is selected to be above the maximum standstill pressure, there is no need to take the measures described above. The disadvantage of this option is that all the components in the low-stage system must be suitable for the selected MAWP. See Section 4 for more information on standstill pressure.

Start-up and Operating Sequence

The start up and operating sequence of a cascade system is critical. The high-stage system must be available to run before starting up or operating the low-stage system. If this is not the case the low-stage system will cut out on the high-pressure protection, and ultimately the pressure-relief valves will discharge.

The High-Stage System

The high-stage system is usually a simple, close-coupled system with a low refrigerant charge. It has a wide range of refrigerant options and is often suitable for natural refrigerants such as Hydrocarbons or R-717. The high-stage can also be R-744, in which case it will be transcritical for part of the year, depending on the ambient temperature.

The high-stage system compressors are typically controlled by the pressure in the low-stage receiver (i.e., the R-744 condensing temperature).

When the load reduces, the R-744 receiver pressure also reduces, so the high-stage compressor capacity reduces. If the load on the R-744 system increases, the receiver pressure will increase causing the high-stage compressor capacity to increase (i.e., high-stage compressors will switch on or speed up).

Section 3. Secondary Systems

The main components in a typical retail secondary loop system are shown in the table below. The 'Ref' column in the table shows the reference to the components in Figure 20.

Table 11. Reference table to what is shown in Figure 20

Component	Type	Ref
Liquid pump	Typically liquid-cooled centrifugal pumps are used	1
Heat exchanger	Standard heat exchangers are used, typically plate heat exchangers	2
Receiver	A standard liquid receiver is usually used	3
Evaporator	Standard HFC evaporators are used	4
High-stage system with compressor	The high-stage system is usually a conventional chiller, operating with HFC or HC	5
Compressor	LT booster compressor	6
Other	Pressure-relief valve: Standard HFC evaporators are used	

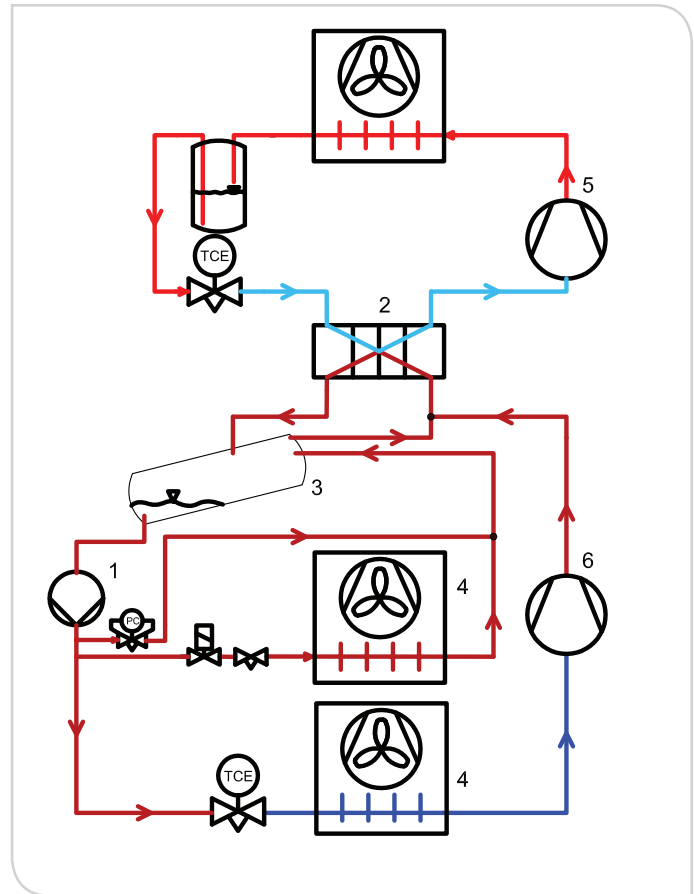

Figure 20. Combined pump circulation system for MT with LT booster system

The R-744 is volatile, so some of the liquid flashes into gas as it absorbs heat in the cabinet.

The R-744 vapor returning to the vessel from the load is then taken from the top of the vessel into the heat exchanger and is re-condensed.

Liquid Pump

The liquid pump is usually a centrifugal type. It is important that pure liquid refrigerant enters the pump to avoid cavitation - flash gas in the liquid will reduce the reliability and performance of the pump. For this reason the receiver must be above the pump. Additionally, the receiver outlet is designed to avoid the formation of flash gas, for example by the incorporation of a vortex breaker (typically a baffle in the receiver outlet). This will stop vortices forming that can entrain vapor in liquid, causing cavitation at the pump.

Pipe Work Temperature

The R-744 liquid will be below ambient so the liquid pipe work must be insulated.

Section 4. Design for Pressure

The operating and standstill pressure of the R-744 systems described above are higher than for other retail refrigeration systems, although many cascade and secondary systems have similar operating pressures to the R-410A systems used in the air conditioning sector. The higher pressures affect the design and specification of all system components and pipe work. The table below shows pressures on the high side of

the system for a “standard” system and a “high MAWP” system. High MAWP systems are specified to avoid the relief valve venting on standstill, when the pressure will exceed the standard pressure-relief-valve rating at ambient temperatures above 42.8°F (the saturation temperature equivalent to 580 psig, see section 2 of Chapter 3 for more information).

Components that are readily available for R-410A systems can generally be used for subcritical systems with a MAWP of 652 psig on the high side. Components that are subject to a higher MAWP are specifically designed for R-744. More detailed information is given in the next chapter and in the Emerson document “*Valves, Controls and System Protectors for R744*”⁶.

The standstill pressure is the internal pressure of the system when it is not operating. The equalized pressure depends on:

- Ambient temperature when below the critical point (for example in an ambient of 68°F the standstill pressure will be approximately 812 psig)
- System volume and refrigerant charge when above the critical point. In this case the standstill pressure depends on the ratio refrigerant charge / system volume and is typically 1740 psig

Table 12. Typical R-744 pressures in retail systems

	Typical Operating Pressure	MAWP	HP Cut-Out Setting
Transcritical Booster Systems			
Low Side, LT	189 psig	435 psig	392 psig
Low Side, MT / interstage Pressure	363 psig	653 psig	580 psig
Intermediate	508 psig	653 psig	580 psig
	870 psig	1015 psig	914 psig
High Side	1305 psig when transcritical	1740 psig	1566 psig
Cascade Systems			
Low Side, Standard MAWP	189 psig (LT evaporator)	435 psig	392 psig
Low Side, High MAWP	189 psig (LT evaporator)	1015 psig	914 psig
High Side, Standard MAWP	392 psig	653 psig	580 psig
High Side, High MAWP	392 psig	1015 psig	914 psig
Secondary Systems			
LT	232 psig	435 psig	
MT	435 psig	653 psig	

⁶Valves, Controls and System Protectors for R744 (2013FC-68 R1) available on www.emersonclimate.com

For many R-744 systems the standstill pressure is greater than the maximum operating pressures. When this is the case systems are either:

- Designed with MAWP based on the maximum operating pressure, in which case the pressure-relief valves will vent when on standstill unless there is some means of reducing the pressure or
- Designed with MAWP based on the maximum standstill pressure

All components and assemblies must be rated for the MAWP of that part of the system.

Pressure-relief valves must discharge to a safe place, ideally outside a building to an unoccupied area.

When evaporators are defrosted the evaporator must be open to the suction of the system and the pack, it must not be isolated.

Section 5. Design for Ease of Service

Systems should be designed with sufficient isolation valves to ensure access can be safely made to components and parts of the system that will require service, including:

- Liquid and suction filters, where a bypass should be fitted so the system can remain in service during replacement
- Oil separators
- Pressure-relief valves

If liquid can be trapped between valves, these sections of the system should include high-pressure protection. This can be achieved either by fitting a pressure-relief valve in that section of the system, or by installing a branch non-return valve and piping it to a section of the system which is protected by a PRV.

Gauges should be provided on the system to give an indication of each of the system pressures (see glossary for an explanation of these pressures):

- Low side: medium- and low temperature
- Intermediate on transcritical systems
- Interstage on booster systems
- High side

These are especially important on R-744 systems:

- To reduce the need for technicians to access the system to fit gauges (specialist R-744 gauges should be used where necessary)
- To avoid the risk associated with technicians fitting

gauges that are not rated for the R-744 pressure

- They give an indication of actual system pressure if vent lines block with dry ice

To make charging easier and safer it is advisable to install a permanent charging point in an area that is easily accessible. This avoids the need to move heavy R-744 cylinders to the plant area.

If R-744 cylinders are stored on site, they should be located in a gas cage, upright and secure, ideally outside a building.

Section 6. Fixed Leak Detection

Fixed leak detection should be used if a leak of R-744 can result in a dangerous concentration in the air. For example, ASHRAE 15 & 34 requires leak detection to be fitted if the concentration can exceed the practical limit of 0.006 lb/ft³. Typically an infrared sensor system is used, with sensors located wherever a leak can accumulate, for example in plant rooms and cold rooms. Typical alarm levels are:

- 5,000 ppm for an initial alarm
- 15,000 ppm for a main alarm

Section 7. Cooling Capacity

The higher gas density of R-744 results in a high volumetric refrigeration effect compared to all other common refrigerants. This has an effect on compressor displacement and the sizing of pipe work, evaporators and condensers.

The chart in Figure 21 compares the cooling capacity of R-744 with R-134a and R-404A for compressors with similar displacements (i.e., similar volume flow rates) in single stage systems:

- 14/86: 14°F evaporating temperature, 11°F suction superheat, 86°F condensing temperature; no liquid subcooling
- 14/104: 14°F evaporating temperature, 11°F suction superheat, 104°F condensing temperature for R-134a and R-404A, 104°F gas cooler outlet temperature and 1305 psig gas cooler pressure for R-744; no liquid subcooling

The compressor power consumption for a given capacity is similar to that for HFCs, so the compressor motor/ displacement combination is different for R-744.

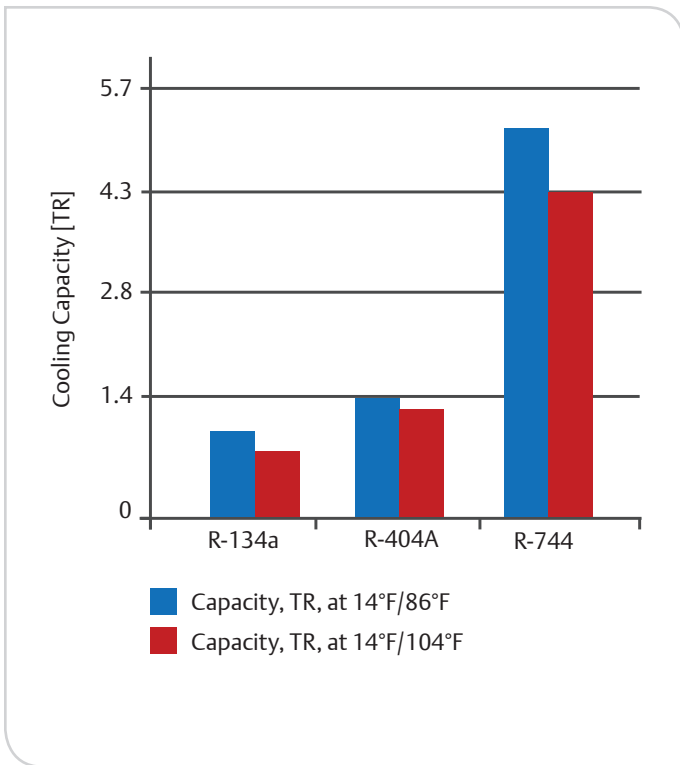

Figure 21. Comparison of HFC and R-744 capacities in typical systems

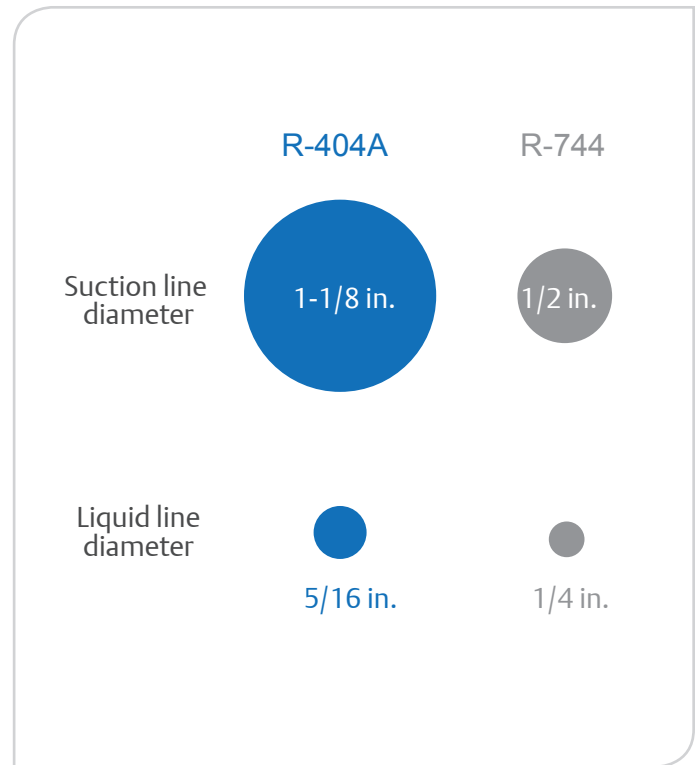

Figure 22. Comparison of pipe sizes for typical systems

Section 8. Capacity Modulation

An R-744 retail system will typically use fewer compressors than an HFC system of the same cooling capacity. This is because the higher capacity of R-744 reduces the total compressor displacement required. Heat exchangers are often smaller, leading to more rapid changes in operating conditions when the load changes. Both these factors increase the need for effective capacity control to meet a varying load.

Section 9. Pipe Work and Jointing

The refrigerant properties which reduce the required compressor displacement also allow smaller diameter pipe work to be used. This is especially true in the suction line carrying superheated gas. The effect on liquid line size is lower because the liquid volume flow is similar to HFCs. The chart in Figure 22 shows one example of the difference in pipe sizing.

The heat transfer coefficient of boiling R-744 is greater than for HFC refrigerants. This will improve the performance of evaporators and condensers, which will allow either:

- The same sized evaporators and condensers to be used compared to HFCs, with greater heat transfer capability and hence lower TDs. This will improve energy efficiency
- Smaller evaporators and condensers to be used (e.g., smaller diameter pipe and fewer passes). This will reduce the component cost and space required

The pressure drop in R-744 pipe work and components is generally lower than with HFCs (especially in suction lines), and the system performance is less sensitive to pressure drop. The system designer can therefore allow for a greater pressure drop. In general refrigerant velocities are similar to those for HFC refrigerants.

The general rules of good pipe design should also be followed with R-744 systems. Pipe thickness will usually be greater because of the higher pressures, and in some cases steel will be used in place of copper. As explained above, smaller diameter pipe is used in some parts of the system. This will inherently withstand higher pressures than larger diameter pipe of the same wall thickness. Table 13 shows the maximum pressure of a range of copper tube.

Table 13. Maximum pressure of a range of copper tube⁶

Nominal Size (inches)	Outside Diameter (inches)	Wall Thickness (inches)	Working Pressure (psi) @ 250°F	
			Annealed	Drawn
¼	0.375	0.035	866	1511
⅜	0.500	0.049	909	1691
½	0.625	0.049	730	1356
⅝	0.750	0.049	611	1132
¾	0.875	0.065	682	1285
1	1.125	0.065	542	1003
1 ¼	1.375	0.065	446	823
1 ½	1.625	0.072	419	773

The most reliable method of jointing copper tube is brazing. The greater thickness reduces the opportunity to swage the pipe and therefore increases the use of fittings. In addition, the heat required for a brazed joint is greater to get the required degree of penetration.

Copper tubing products are now available specifically for use on R-744 systems with a MAWP of 1740 psig (K65, Streamline XHP). The material comprises copper with 2.4% ferrous plus

very small amounts of zinc and phosphorous. It cannot be bent or swaged, so is joined using proprietary brazed fittings.

Steel pipe will withstand a greater pressure than copper tube, as shown in Table 14 for Schedule 40 pipe.

Table 14. Steel pipe withstands a greater pressure than copper tube (psi)

¼"	⅜"	½"	¾"	1"	1 ¼"	1 ½"	2"	2 ½"	3"
6438	5177	4959	4017	3756	3089	2770	2335	2567	2219

Piping should be adequately supported and clamped. Pipe supports should be closer than for other refrigerants due to the higher density of R-744 and therefore weight of refrigerant in pipes. The following tables provide guidance on this.

Table 15a. Copper pipe sizes and their maximum spacing of supports

Copper pipe sizes O.D.		Maximum spacing of supports	
(in)	(mm)	(ft)	(m)
⅜ - ¾	10 - 19	3.28	1
⅞ - 2 ⅞	22 - 54	6.56	2
2 ⅝ - 3 ⅞	67 - 80	9.84	3

Table 15b. Steel pipe sizes and their maximum spacing of supports

Steel pipe sizes nominal bore		Maximum spacing of supports	
(in)	(mm)	(ft)	(m)
½ - 1	15 - 25	3.28	1
1 ¼ - 2	32 - 50	9.84	3
2 ⅓ - 3	65 - 80	11.48	3.5
4 - 7	100 - 175	13.12	4
8 - 14	200 - 350	19.69	6
16 - 18	400 - 450	24.60	7.5

⁶ Publication A4015-14/16: Copper Tube Handbook Copper - Development Association; UL 207 Standard for Safety for Refrigerant-Containing Components and Accessories, Nonelectrical ASTM A53 B Standard for continuous weld (CW) pipe.

Section 10. Lubricants and Oil Return

Polyolester (POE) lubricants have good miscibility with R-744 and are predominantly used as compressor lubricants in retail R-744 systems. Because of the high solubility, higher viscosity lubricants are used when compared to those used with HFCs. This reduces the effect of oil dilution by refrigerant and therefore maintains the lubricant properties.

POE oils are very hygroscopic (i.e., they readily absorb moisture), so care must be taken to ensure moisture does not enter the system:

- The lubricant must not be exposed to air, and oil containers must be sealed except when the oil is being dispensed
- Components such as the compressor must also be sealed, except when work is actually being performed
- The evacuation process must be effective
- Replacement drier cores must be fitted whenever the system is open and exposed to air

R-744 liquid is heavier than oil, as is the case with HFC refrigerants. Effective oil separation and return to the compressor is necessary on retail systems. Typically this is best achieved by the use of coalescent-type oil separators and, for multiple compressors, a conventional oil-return system.

Section 11. Materials

R-744 is compatible with most material used in retail refrigeration systems. Elastomers must be carefully selected as R-744 penetrates the material more than other

refrigerants would. When seals made of these materials are depressurised, the absorbed R-744 rapidly evaporates causing explosive decompression and damage to the seal. Some seal materials swell and soften with R-744.

Steel pipe work is often used in R-744 systems because of the high pressures, especially in discharge lines and headers. Steel can become brittle at low temperatures. In the event of a leak the temperature can reduce to near -108.4°F , so low temperature steel must be used.

Section 12. Potential for Heat Reclaim

The discharge temperature of an R-744 system is higher than for HFC systems running at similar evaporating and ambient temperatures. This provides more potential for the reclaim of heat at a useful temperature.

Additionally, when the refrigerant is transcritical its temperature in the gas cooler reduces throughout the heat exchange process – all heat rejection occurs at a changing temperature. This is an advantage over a subcritical condenser where the refrigerant temperature reduces only as it de-superheats, and this is for a small part of the process. It then remains at a constant temperature (the condensing temperature) as it condenses. The majority of the heat rejection occurs at constant temperature.

The charts in Figure 23 illustrate this point and compare an R-134a system to an R-744 transcritical system. It can be seen that the final media temperature can be significantly higher for the R-744 system.

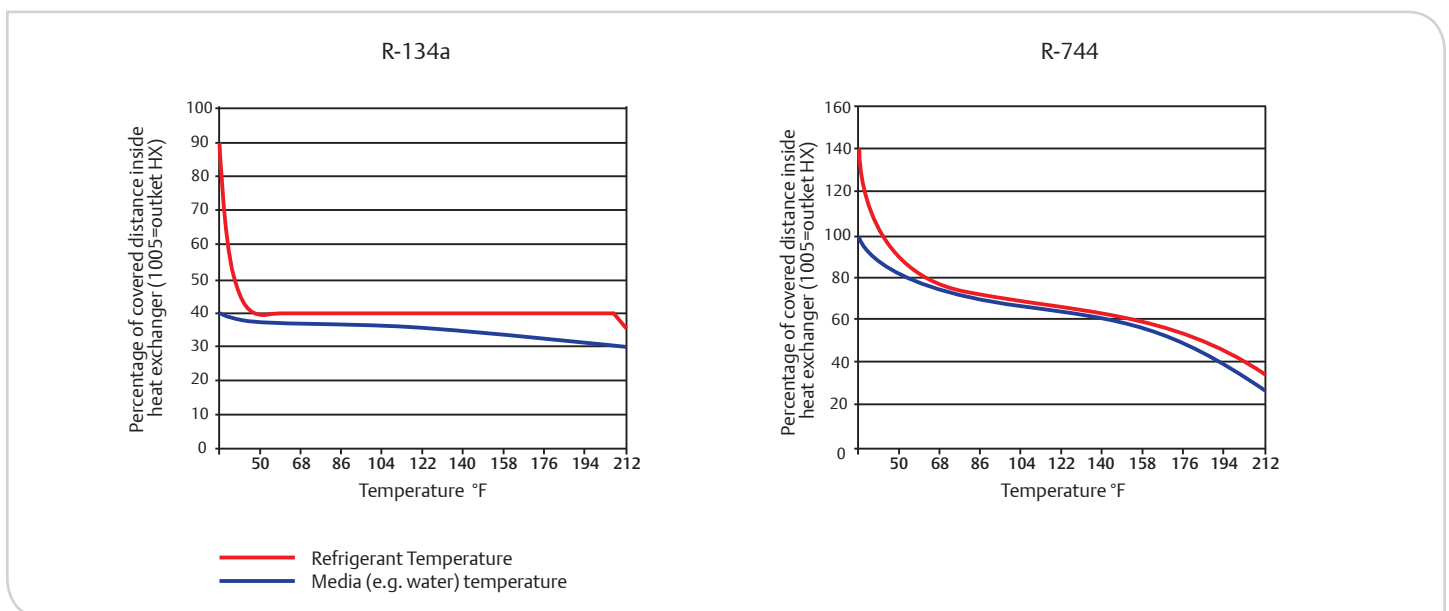

Figure 23. Heat Reclaim comparison of R-134a system to R-744 transcritical system

5 R-744 Systems: Installation, Commissioning and Services

Introduction

This chapter covers some of the key points when systems are commissioned and operating, and important service and maintenance issues. This chapter is not a complete guide to commissioning and service.

Technicians installing, commissioning, servicing and maintaining R-744 systems must be trained in the safe handling of this refrigerant before working on these systems. Key points about the hazards of R-744 must be taken into account when working on these systems:

- System and cylinder pressures are high, e.g. approximately 725 psig at 59°F
- R-744 is an asphyxiate (the practical limit in ASHRAE 15 & 34 is 40,000 ppm)
- There is a high risk of freeze burns from liquid or solid R-744
- There is a high risk of excessive pressure with trapped liquid or gas; 1.8°F increase in temperature produces 145 psi increase in pressure
- There is a risk of solid R-744 formation when venting liquid or charging liquid into an evacuated system
- R-744 (refrigerant-grade CO₂) must be used to ensure low levels of moisture
- Appropriate personal protective equipment, including gloves and goggles, must be worn
- R-744 cylinders are heavy, so care is needed. They must be secured when handling. Unsecured they can move when opened
- The correct cylinder adaptors must be used – connections must not be bodged
- R-744 rated equipment for charging and venting must be used. Standard gauge manifold hoses must not be used

- The correct case and plant isolation procedures must be followed to avoid trapping liquid in service lines, pipe work or components
- Systems must not be brazed or welded with R-744 still in the system / part of system

Section 1. Good Installation Practice

Sufficient time should be provided so that systems can be fully pressure tested for strength and leak tightness prior to being put into service. This avoids future issues associated with reliability.

Pipe Work

Pipe work should be routed in accordance with good refrigeration practice, to minimise pressure drop and allow oil return to the compressor. It is important that pipe work is correctly supported and fixed as outlined in Chapter 3.

A pipe which is not correctly fixed will whip at high speed if the pipe or joint ruptures, potentially causing injury or fatality.

Vent lines from pressure-relief valves should discharge refrigerant to a safe place. This is typically to an unoccupied area outside a building or plant enclosure, to where the refrigerant will disperse without risk of asphyxiation. The PRV vent lines should be of sufficient diameter to prevent R-744 solidifying and blocking the vent line itself.

The most reliable method of jointing pipe work is to braze or weld. It is advised for all joints that welders and brazers are approved to a nationally recognised standard. Special attention should be made to the hazard category of the joint and the required levels of competency and certification to carry out the brazing or welding. Mechanical joints should be avoided where possible. If they are used the fittings must be rated for the pressure and the jointing procedure specified by the manufacturer must be followed.

Table 16. Maximum Support Spacing for copper and steel pipes

Copper Pipe OD (in)	Maximum Support Spacing (ft)	Steel Pipe Nominal Bore (in)	Maximum Support Spacing (ft)
3/8 to 3/4	3.28	1/2 - 1	3.28
7/8 to 1 1/8	6.56	1 1/4 - 2	9.84
5/8 to 1 1/8	9.84	2 1/2 - 3	11.48
		4 - 7	13.12

Pressure Testing

The completed installation should be pressure tested for strength and leak tightness in accordance with local standards. This is typically:

- Minimum Pressure Test = 1.10 x MAWP
- Maximum Pressure Test = 1.30 x MAWP
- Leak tightness test at 1.0 x MAWP.

The relevant standard must be referred to for specific pressure testing requirements⁷. Components and assemblies such as compressors and packs do not usually need to be pressure tested onsite as they have already been tested by the manufacturer.

Pressure-relief-valves should be isolated during pressure testing. Good practice should be followed when pressure testing:

- Equipment, including the nitrogen regulator, should be rated for the pressure, an example is shown in Figure 24
- The area must be evacuated of anyone not directly involved in the pressure testing
- Oxygen free nitrogen should be charged slowly into the system and an initial check carried out at approximately 25 psig
- The strength test pressure should be held for a minimum of 15 minutes
- The nitrogen used for leak testing should be vented to a well-ventilated area, ideally outside
- The pressure should be reduced to the tightness test pressure and each joint checked with leak detection spray, or the pressure held and monitored over at least 24 hours

Evacuation

Systems must be thoroughly evacuated to remove non-condensable gases and moisture – both will have an adverse impact on R-744 systems.

Non-condensable gases such as air and nitrogen tend to accumulate in the condenser or gas cooler, where they cause an increase in pressure. This leads to a reduction in capacity, efficiency and reliability of the system. The effect of non-condensable gases in an R-744 system is greater compared to HFC systems, especially transcritical systems.

High moisture content will result in system failures, for example, water and carbon dioxide produce carbonic acid.

Table 17. Maximum solubility of moisture in R-744

R-744 State	Temperature	Maximum Moisture ppm
Liquid	-40°F	130
	14°F	405
Vapor	-40°F	7
	14°F	33



Figure 24. Example of regulator suitable for pressure testing transcritical R-744 systems

⁷ ASME Boiler and Pressure Vessel Code (BPVC); ASME B31.5 - Refrigeration Piping and Heat Transfer Components; UL 207 - Refrigerant Containing Components and Accessories, Nonelectrical; CSA B51 - Boiler, Pressure Vessel and Pressure Piping Code; CSA B52 Mechanical Refrigeration Code

If the moisture content is above the maximum ppm as shown in Table 18, there will be free moisture that can freeze. This is most likely in the superheated vapor between the exit of the evaporator and compressor suction, especially with LT evaporators. If moisture is allowed to accumulate in a static part of the system it can freeze and expand, causing pipe failure.

Great care should be taken during any service procedures to minimise the ingress of air and moisture to avoid the problems highlighted above.

Section 2. Charging R-744

R-744 is available in cylinders with either a liquid take-off- or a gas take-off-valve and is also available in bulk. The cylinders are heavier than other refrigerant cylinders, so care is needed when handling them – for example, they should be moved on a trolley. They are generally less stable than other refrigerant cylinders because of their diameter to height ratio, so they should be secured when in use and when they are stored or transported.

The equipment used to connect the cylinder to the system must be rated for the pressure. Typically hydraulic hose or braided steel hose is used.



Figure 25. Example of R-744 charging equipment

The connection to the cylinder must be the correct fitting for the cylinder valve – a standard adaptor for an HFC cylinder must not be used.

All charging lines should be evacuated or purged prior to charging to reduce the ingress of air and moisture into the system.

To prevent dry ice formation, the evacuated system should be charged with R-744 vapor to a pressure above the triple point (75.1 psia). The whole system must be above the triple point – this is likely to be the case if all the gauges show a pressure of 145 psig. When this is achieved the system can then be charged with liquid.

Care must be taken when charging R-744 systems to ensure pressure-relief valves do not discharge. The R-744 cylinder pressure will be greater than some or all of the PRV relief pressures, especially those on the low-stage of cascade systems and the low and intermediate sides of transcritical booster systems. To avoid PRV discharge the refrigerant should be charged slowly to allow system pressure to equalise, especially during initial bulk charging (“bomb” charging) of the system.

Charging the Low-Stage of Cascade Systems

Before the low-stage of a cascade system is charged, the high-stage must be available to run. So the high-stage must be charged and commissioned before the low-stage is charged.

Charging a Transcritical Booster System

It is unlikely that all of the refrigerant will be able to be charged without running the system. The system should not be topped up by charging into the suction. Systems with an intermediate pressure that is higher than the cylinder pressure should be pumped down or the intermediate pressure reduced to enable refrigerant to be charged. Alternatively, the cylinder pressure can be increased by heating the cylinder with a thermostatically controlled heater.

The high-stage compressors must be available to operate before the low-stage compressors can be started.

Section 3. System Checks

Before the system is operated for the first time, the following should be checked:

All Systems:

- Visual inspection
- Documentation for the system and its marking, especially with regard to pressure equipment
- Installation of the safety devices
- Control tests to ensure all controls function correctly, including high, low and oil-pressure cut-outs, interlocks, transducers and control devices. This should include any manual back up system
- Set pressure of all safety devices and other pressure cut-outs
- Set pressure of the gas cooler pressure regulating valve
- Compressor and oil reservoir oil levels
- Cores are fitted in the filter driers
- The pressure test records
- All valves are open / closed as required to operate the system

During initial operation the following should also be checked:

- Phase rotation of scroll compressors
- Fan rotation; check before starting compressors – turn fans on manually
- Refrigerant level
- Oil level in compressors and oil reservoir
- Expansion valve superheat
- Pressure and temperature of the cascade heat exchanger
- Regulating valve in both subcritical and transcritical mode
- Operating pressure of the receiver pressure regulating valve
- Operation of any auxiliary cooling unit

Section 4. Service

General

Work should be carried out in a well-ventilated area. If there is no operational permanent leak detection, the technician should use a personal R-744 detector to ensure the area is safe to work in. Appropriate personal protective equipment, including gloves, safety glasses and ear protectors should be used. Tools and equipment such as hoses should be rated for the pressure of the system, R-744 cylinder and nitrogen cylinder where used.

Care should be taken when accessing the system – the technician should be familiar with the system and should understand how sections of the system are safely isolated. This includes the effect on the system of closing valves and the potential for trapping liquid R-744 between closed valves.

Leak Detection

R-744 systems can have a high leak potential because of the higher pressures and smaller molecule size. Retail R-744 central plant systems have a high number of joints which further increases leak potential. Leakage is hazardous and increases the energy consumption of the system. So although R-744 has a very low global warming potential, leak detection is critical.

Leaks can be detected using the following methods:

- Visual inspection – many leaks result in oil stains on and around the system
- Leak detection spray, although this is difficult on insulated joints and sections of the installation below 32°F
- Hand held electronic leak detector suitable for R-744, typically using infrared technology, an example is shown in Figure 26
- Ultrasonic leak detector



Figure 26. Example of an electronic leak detector suitable for R-744

Leak detection should be methodical and the whole system checked. Leaks should be repaired as soon as possible after detection. To maintain energy efficiency it is recommended that retail R-744 systems are checked for leaks following, at a minimum, the same regimen as specified in the European Fluorinated Gas Regulation⁸ for HFC refrigerants , as shown in Table 18

Table 18. US/Canadian Leak Detection Frequency

US EPA (Section 608 - Refrigerant Management Regulations)	
Stationary Leak Detection Equipment or	
Annual Inspection (>=50 lbs Refrigerant Charge)	Quarterly Inspection (>=500lbs Refrigerant Charge)
Environment and Climate Change Canada (Federal Halocarbon Regulation)	
Annually (System Capacity >= 5.4 TR)	

⁸Federal Halocarbon Regulations, 2003 (SOR/2003-289)
US EPA - Section 608 - Refrigerant Management Regulations

Disposal of R-744

R-744 is usually vented from systems rather than being recovered. It is important it is safely vented to a well-ventilated area, ideally to outside a building. It is an asphyxiate with low toxicity.

Dry ice can form in the vent line or in the system as the pressure drops through the triple-point pressure (75.1 psia) to atmospheric pressure. This can give a false indication that the system is devoid of refrigerant – if dry ice forms the refrigerant pressure will drop to 0 psig. When the dry ice sublimates the pressure will increase, for example to 812 psig if the temperature is 68°F.

If R-744 is recovered, the recovery machine, cylinder and any associated equipment must be rated for the maximum pressure. This would be 1015 psig in an ambient of 86°F for example, but could be significantly higher if the ambient is greater. Most recovery machines and cylinders are not rated for the required pressure.

Isolation of Components for Service

When isolating components for service care must be taken to ensure R-744 liquid is not trapped between closed valves in an unprotected part of the system. Control valves should not be used as isolation valves. Welding or brazing should not be

carried out on the system until the R-744 has been removed. Care should be taken when removing flanges to ensure all the R-744 has been removed and the pressure is as low as possible:

- All bolts should be slacked
- The flange should be loosened with at least two bolts still in place

There are various methods of removing the R-744:

- It can be vented as described above
- It can be transferred to another part of the system
- It can be evaporated as described below

The procedure below is an example for isolating the evaporator in a cabinet and is from *The British Refrigeration Association's Code of Practice for Isolation of a Display Cabinet Evaporator from a Carbon Dioxide (R7-44) System*. The example in Figure 27 shows a typical arrangement of isolation valves.

1. Mount a gauge to the access port on the ball valve (B)
2. Isolate the inlet ball valve (A) while the control valve (C) is open. Ensure the control valve is open using a permanent magnet
3. Allow the coil to pump out for 15 minutes
4. Isolate the evaporator coil outlet ball valve (B)
5. Immediately proceed to vent refrigerant from the access port A while the pressure is being observed on the gauge

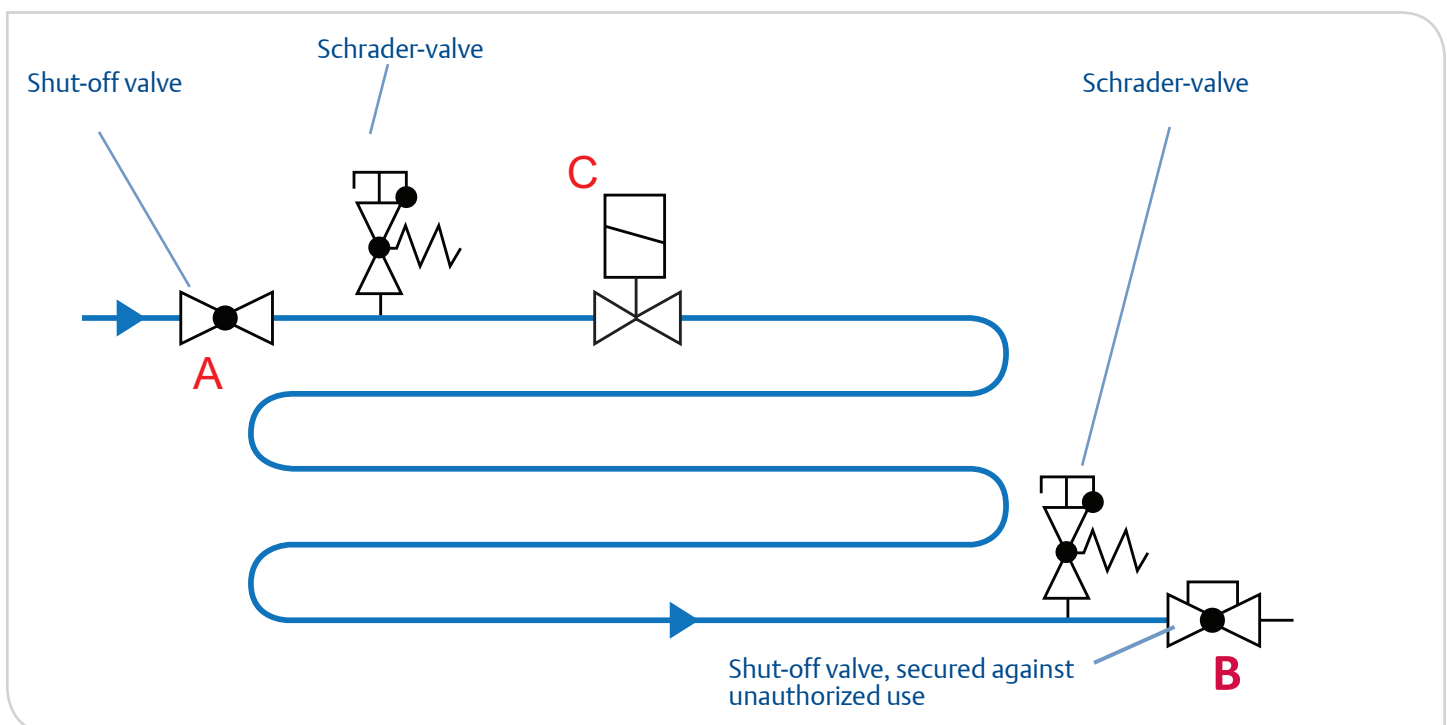

Figure 27. Isolation of components for service

6. Monitor the pressure in the coil at the coil outlet through service valve B. This is essential to be sure the refrigerant has been fully removed and that the service valve ahead of the liquid control valve C hasn't become blocked with solid carbon dioxide (R-744)

Note: With reference to the above step 3, an estimated time of fifteen minutes would be enough time to ensure a reasonably frost free coil with the fan running. When all frosting on the coil has stopped, the liquid has evaporated.

Isolation of Filter dryer for service

The procedure below is an example for isolating the filter dryer in the liquid line of a cascade system. The example in Figure 27 shows a typical arrangement of isolation and bypass valves.

Explanation of the below circuit:

1. Valve 1 is closed
2. After approximately 15 minutes valve 2 is closed and valve 3 opened
3. A suitable gauge manifold set is fitted to the drier core housing
4. The remaining R-744 is carefully vented via the gauge manifold

It is probable that dry ice will have formed in the drier housing as it is usually not possible to remove all the liquid from the housing, as shown in the example in Figure 29. It will deposit to solid when the pressure is reduced during venting. It will have a surface temperature of approximately -109.3°F so it should be carefully handled. Because of the low temperature, moisture will condense on the inside of the housing (see Figure 30) – it is essential this is removed to avoid the moisture related problems outlined earlier.

Before putting the drier back into service it should be evacuated. Gas should be charged into the drier housing to above the triple-point pressure before opening it up to the liquid line to avoid dry ice formation. The gas can be taken from an R-744 gas off-take cylinder or from the suction of the system.

Charging Compressor Oil

If oil needs to be added into the system it must be the correct type – oils of a different make or viscosity should not be mixed. Copeland R-744 compressors use lubricant RL68HB.

Care should be taken when oil is added to avoid moisture and air ingress to the system. The oil should be pumped and not poured into the system. Oil should not be charged into a system if the container has been opened previously.

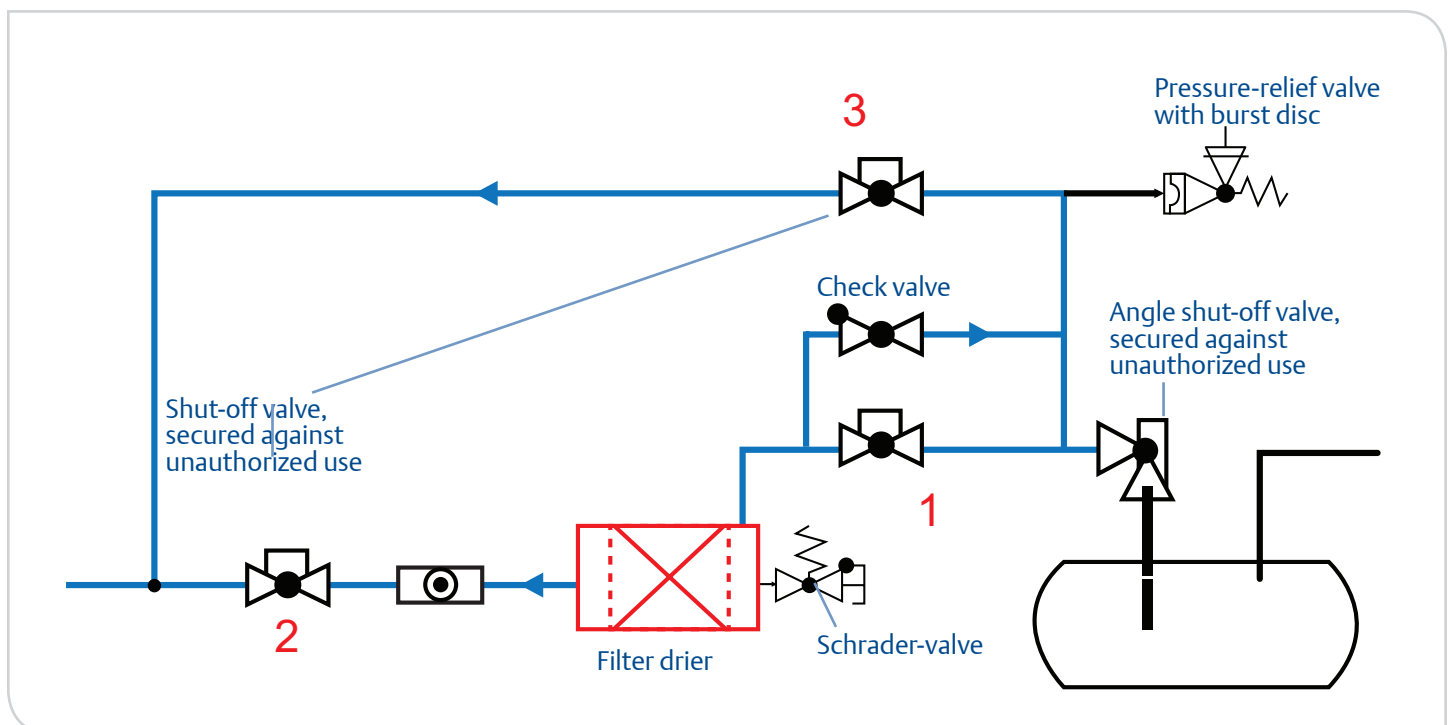

Figure 28. Isolation of filter dryer for service



Figure 29. Example of dry ice formation in a drier

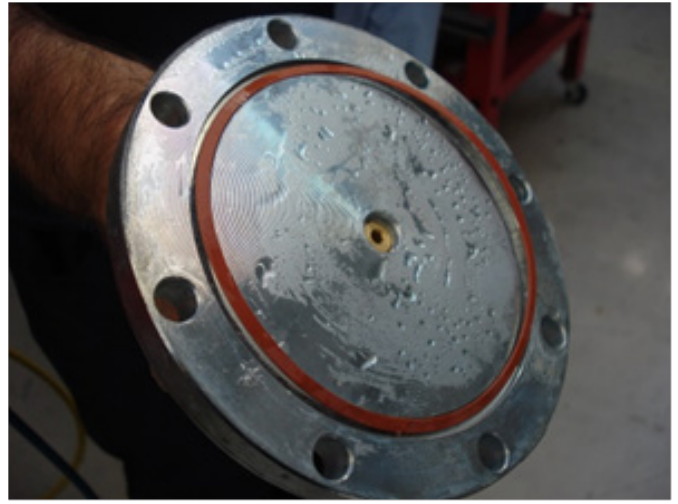

Figure 30. Example of moisture on the flange of a drier

Section 5. Taking the System Temporarily Out of Service

If a system is to be switched off, it is possible that the standstill pressure will be above the discharge pressure of some or all of the pressure-relief valves. If there is an auxiliary cooling system it is possible that this can be used to keep the pressure below the PRV discharge pressures for short periods of time if there is no load on the system. Otherwise the refrigerant should either be:

- Vented from the system, or
- Pumped down into the high side of the system of the receiver if large enough and if the pressure will not cause the high side PRVs to discharge. For transcritical systems, as well as the receiver-outlet valve or liquid-line solenoid valve, the receiver pressure-regulating valve should be closed to achieve a pump down.

Section 6. Maintenance

R-744 systems should be maintained in accordance with good refrigeration practice. This would include:

- A general check of the system condition
- Check oil level
- Check refrigerant level
- Inspect and test safety cut-outs, transducers and sensors
- Change oil filters and filter driers as required
- Carry out an acid test on a sample of oil
- Check R-744 detectors and alarms
- Check control valve operation in line with manufacturers, guidance
- Check plant room ventilation

Conclusion

High pressure CO₂ systems were already developed end of the 19th century and used in many refrigeration applications. In the last 15 years this technology was identified as an environmental friendly solution in commercial refrigeration based on the low Global Warming Potential (GWP) of CO₂ and resulting in lower Total Equivalent Warming Impact (TEWI) compared with HFC Refrigerants. The applications are mainly cold stores and supermarket retail systems.

Different system concepts for cold and warm climates like indirect secondary systems, cascade or booster systems were developed. Especially in cold climates the CO₂ systems can show better energy efficiency compared with HFC systems, because the temperature profile allow the subcritical operation with very high coefficient of performance. In warm climates cascade systems using CO₂ in the low temperature stage and a low GWP refrigerant for the medium temperature could be a high efficient solution. Furthermore, CO₂ is ideal for heat recovery and combine heating and cooling at the same time which results in a significant reduction of the CO₂ emissions of the building. Tools like the “Right Balance

Calculator” can help to identify the best solution for the environment impact (TEWI), investment and energy cost.

CO₂ provides is a viable option to deal with today’s and future environmental challenges.

Temperatures of both load and ambient may be unchanged, but the physical properties of CO₂ cause it to behave in a different way under the conditions needed to deal with the medium and low temperature refrigeration requirements. In particular, the pressure, and phase change behaviour are very different to fluids previously chosen for vapor compression systems. These properties can offer significant advantages over traditional technologies, but in order to take advantage of this it is necessary to come to terms with those properties.











There is a real advantage in developing a CO₂ competent team giving a competitive edge, driving up industry standards, and leading to more end user respect. This can only benefit the industry as a whole, and Emerson is dedicated to supporting clients working to achieve these objectives.

Glossary

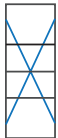
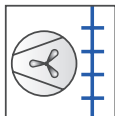
The table below provides definitions of terms relating to CO₂. Other refrigeration terms are defined in ASHRAE 15 & 34, CSA B52 and various other publications and text books.

Booster	A two-stage system where the low-stage compressor(s) discharge into the suction of the high-stage compressor(s).
Cascade	A two-stage system where the heat rejected by the low-stage system is absorbed by the evaporating refrigerant in the high-stage system.
Cascade heat exchanger	The evaporator of the high-stage system and the condenser of the low-stage system in a cascade. The evaporating high-stage refrigerant absorbs the heat rejected by the condensing low-stage refrigerant.
Cascade low-stage	The part of the cascade system that provides the cooling. In retail systems this will run often on R-744. The pressure will usually be higher than the high-stage (see below).
Cascade high-stage	The part of the cascade system that absorbs the heat from the condensing low-stage refrigerant and rejects it, usually to ambient air.
Critical point	Condition above which distinct liquid and gas phases do not exist.
Deposition	Process of gas transforming to solid.
Dry ice	Solid form of carbon dioxide.
Gas	State when temperature is above the critical temperature but pressure is below critical pressure.
Gas cooler pressure-regulating valve	The valve that regulates the pressure in the gas cooler and associated pipe work. It is controlled from the pressure and temperature at the outlet of the gas cooler. It is also called the high-pressure regulating valve.
Interstage	The section of a booster system between the discharge of the low-stage compressor(s) and the suction of the high-stage compressor(s).
Intermediate	The section of a transcritical system between the outlet of the gas cooler pressure-regulating valve and the inlet of the receiver pressure-regulating valves and the inlet of the expansion devices.
MAWP	The maximum allowable working pressure a system is rated for.
Receiver pressure regulating valve	The valve that regulates the pressure in the liquid receiver and associated pipe work. It is also called the medium pressure regulating valve or the flash-gas bypass valve.
Subcritical system	A system that operates below the critical point.
Sublimation	Transition from solid to gas without passing through the liquid phase.
Supercritical fluid	State when both the temperature and the pressure are above the critical point. The substance is not a gas, vapor or liquid.
Transcritical system	A system which operates above the critical point. Many transcritical systems are subcritical for a proportion of the year.
Triple point	Condition at which solid, liquid and gas coexist.
Vapor	State where temperature and pressure are below critical conditions.
Volatile	A volatile substance is one that evaporates readily at normal temperatures.

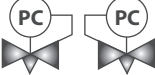
The table below provides information about the symbols that are shown in the circuits in Chapters 3 and 4.

	Compressor		Liquid Receiver (flash tank)
	Piston Compressor		Liquid Receiver
	Gas Cooler/ Condenser		Cascade Heat Exchanger/ Heat Recovery Heat Exchanger
	Evaporator		Liquid Pump
	Expansion Device		Oil Separator and Oil Return System
	Gas Cooler Regulating Valve		

List of Figures

Figure 1. Copeland™ Transcritical compressor for R-744	4
Figure 2. Copeland™ Scroll ZO compressor for R-744	4
Figure 3. R-744 / CO ₂ phase diagram.....	6
Figure 4. Pressure enthalpy chart for R-744	7
Figure 5. Pressure temperature relationship comparison	8
Figure 6. R-744 pressure enthalpy chart showing subcritical and transcritical systems	8
Figure 7. Relationship between temperature and pressure of trapped liquid R-744. Source: Danish Technological Institute	10
Figure 8. Simple transcritical system for medium temperature	13
Figure 9. Pressure enthalpy chart showing transcritical operation	14
Figure 10. Typical retail system with single stage	15
Figure 11. Simple booster system without oil management.....	16
Figure 12. Simple cascade system.....	16
Figure 13. Retail cascade system.....	17
Figure 14. Comparison of system types, Rochester, NY.....	19
Figure 15. Comparison of system types, Atlanta, GA.....	19
Figure 16. Variables used in comparison calculations	20
Figure 17. Pressure enthalpy chart showing two interstage conditions	21
Figure 18. Typical retail transcritical booster system	22
Figure 19. Typical retail cascade system.....	23
Figure 20. Combined pump circulation system for MT with LT booster system.....	25
Figure 21. Comparison of HFC and R-744 capacities in typical systems	28
Figure 22. Comparison of pipe sizes for typical systems	28
Figure 23. Heat Reclaim comparison of R-134a system to R-744 transcritical system	30
Figure 24. Example of regulator suitable for pressure testing transcritical R-744 systems.....	32
Figure 25. Example of R-744 charging equipment.....	33
Figure 26. Example of an electronic leak detector suitable for R-744.....	34
Figure 27. Isolation of components for service	35
Figure 28. Isolation of filter dryer for service	36
Figure 29. Example of dry ice formation in a drier	37
Figure 30. Example of moisture on the flange of a drier	37

List of Tables

Table 1.	How R-744 meets different conditions and criterias.....	5
Table 2.	Basic properties of R-744 compared with other refrigerants	7
Table 3.	Effects of CO ₂ at various concentrations in air	9
Table 4.	R-744 standstill and typical system operating pressures.....	10
Table 5.	Comparison of R-744 with other refrigerants.....	11
Table 6.	Advantages and disadvantages of R-744 as a refrigerant	12
Table 7.	Advantages and disadvantages of cascade and transcritical retail systems	18
Table 8.	Advantages and disadvantages of two typical intermediate pressures.....	22
Table 9.	Reference table	22
Table 10.	Reference table	23
Table 11.	Reference table	25
Table 12.	Typical R-744 pressures in retail systems	26
Table 13.	Maximum pressure of a range of copper tube.....	29
Table 14.	Steel pipe withstands a greater pressure than copper tube.....	29
Table 15a.	Copper pipe sizes and their maximum spacing of supports.....	29
Table 15b.	Steel pipe sizes and their maximum spacing of supports	29
Table 16.	Maxium Support Spacing for copper and steel pipes.....	31
Table 17.	Maximum solubility of moisture in R-744	32
Table 18.	US/Canadian Leak Detection Frequency	34

List of References

2013 ASHRAE Handbook - Fundamentals

ASHRAE 15 & 34 Safety Standard for Refrigeration Systems and Designation and Classification of Refrigerants

ASME Boiler and Pressure Vessel Code (BPVC)

ASME B31.5 - Refrigeration Piping and Heat Transfer Components

ASTM A53 B Standard for continuous weld (CW) pipe.

CSA B51 - Boiler, Pressure Vessel and Pressure Piping Code

CSA B52 - Mechanical Refrigeration Code

Federal Halocarbon Regulations, 2003 (SOR/2003-289)

International Institute of Refrigeration 2011, *CO₂ as a Refrigerant*. Editor: Dr A. B. Pearson. First Edition, Paris, France.

Life Cycle Climate Performance Energy Tool. Emerson Climate Technologies, www.emersonclimate.com.

Manufacturer published data

NIST REFPROP version 9.1

Publication A4015-14/16: Copper Tube Handbook Copper - Development Association

Refrigerant Choices for Commercial Refrigeration (TGE124-0910/E)

UL 207 - Refrigerant Containing Components and Accessories, Nonelectricla

US EPA - Section 608 - Refrigerant Management Regulations

Valves, Controls and System Protectors for R744 (2013FC-68 R1) available on www.emersonclimate.com



Emerson Climate Technologies at a Glance

Emerson Climate Technologies is the world's leading provider of heating, ventilation, air conditioning, and refrigeration solutions for residential, industrial and commercial applications. We combine technically superior products and services from our industry leading divisions and brands with

our global engineering, design and distribution capabilities to create reliable, energy efficient climate systems that improve human comfort, safeguard food, and protect the environment.

For more details, see:

www.EmersonClimate.com/CO2

www.EmersonClimate.com/CO2Tool

The Emerson Climate Technologies logo is a trademark and service mark of Emerson Electric Co. Emerson Climate Technologies Inc. is a subsidiary of Emerson Electric Co. Copeland is a registered trademark and Copeland Scroll is a trademark of Emerson Climate Technologies Inc.. All other trademarks are property of their respective owners. Emerson Climate Technologies shall not be liable for errors in the stated capacities, dimensions, etc., as well as typographic errors. Products, specifications, designs and technical data contained in this document are subject to modification by us without prior notice. Illustrations are not binding.

© 2016 Emerson Climate Technologies, Inc.

EMERSON. CONSIDER IT SOLVED.™