



Leduc Overhead Door Inc.

#104, 6051-47 Street, Leduc, AB T9E 7A5

Phone: 780-986-1295

Email: service@leducoverheaddoor.com

Commercial Overhead Door Safety Compliance **A Reference Guide for Safety Professionals**



This guide is written for safety professionals with safety and OHS compliance responsibility in organizations with commercial overhead door systems.

Summary

Even though overhead door systems are very common, they are almost always overlooked as safety hazards, even in organizations with excellent safety programs.

But this oversight can have catastrophic consequences as commercial overhead doors are heavy, hang high in the air, are dynamic, and often operate in building openings where there is pedestrian traffic.

Each year, there are far too many examples of “struck by” and “crushing” incidents^{1,2,3} involving overhead doors that are avoidable given regular door maintenance / inspections, and the inclusion of recommended safety entrapment devices.

OHS Compliance

Overhead doors systems are subject to OHS compliance requirements. In Alberta, the applicable standards are **Part 3(12)(d) of the Code⁴**, which requires equipment to be installed and maintained in accordance with manufacturer’s specifications; and, **Section 2(1) of the Act⁵**, the “general duty of care” provision.

Main types of commercial overhead doors:

Sectional doors	Rubber doors
Rolling steel service doors	Fabric doors
Rolling steel fire doors	Rolling grilles
High speed doors	



Sectional overhead door

How to Properly Include Overhead Doors in Your Safety Program

To comply with OHS regulations, and minimize safety risk, a planned maintenance and safety compliance program must be implemented for your overhead doors that meets the criteria below. Inspection, maintenance and repair work is typically performed by a qualified overhead door service company.

1. Maintenance Practices, Standards & Intervals

All door systems must be **installed, inspected & maintained in accordance with the manufacturers’ specifications**. This **includes maintenance intervals**, which can vary depending on daily cyclage and operating environment. If manufacturer’s specifications are not available, then the PM program should adhere to established industry standards/best practices.

2. Documentation & Reporting

Thorough, secure documentation should be maintained that details:

- ✓ The practices and standards used to inspect and maintain doors (eg. manufacturer’s operating/maintenance manuals, or similar documentation)
- ✓ Any problems or deficiencies found, preferably with photographs

- ✓ Corrective work required, and/or opportunities to improve safety
- ✓ Corrective work performed

3. Entrapment Devices

All motorized door systems must be equipped with **entrapment devices to manufacturer's standards, such as photo-eyes or sensing edges**. If there are door systems equipped with older devices not current with newer, improved safety standards, modernizing should be considered where reasonably practicable; for example, upgrading to monitored entrapment devices.

Occupational Health & Safety Legislation in Alberta

Overhead doors are subject to the standards of **Part 3(12)(d)** of the Alberta Health and Safety Code⁴ and **Section 2(1)** of the *Act*⁵.

12 An employer must ensure that ...

(d) equipment and supplies are erected, installed, assembled, started, operated, handled, stored, serviced, tested, adjusted, calibrated, maintained, repaired and dismantled in accordance with the manufacturer's specifications or the specifications certified by a professional engineer.

Obligations of employers, workers, etc.

2(1) Every employer shall ensure, as far as it is reasonably practicable for the employer to do so,

- (a) the health and safety of
 - (i) workers engaged in the work of that employer, and
 - (ii) those workers not engaged in the work of that employer but present at the work site at which that work is being carried out, and ...

Part 3(12)(d) of the Code is specific in its requirement that equipment, which includes overhead doors, be installed and maintained to manufacturer's specifications (or otherwise certified by a professional engineer). Most overhead door and operator manufacturers publish installation and/or operations manuals that can be used as reference materials; however, these can be difficult to locate, or may not be available at all.

Section 2(1) of the *Act* requires employers do what is "reasonably practicable" to ensure a safe work environment. "Reasonably practicable" has been described by the Canadian Labour Program as taking precautions that are not only possible, but that are also suitable or rational, given the particular situation.

Safety professionals also use the term “due diligence” to describe the standards of Section 2(1). Due diligence is the level of judgement, care, prudence, and activity that would be reasonably expected under the particular circumstances. To exercise due diligence, an employer must implement a plan to identify possible workplace hazards and carry out the appropriate corrective action to prevent accidents or injuries arising from these hazards (eg. ensure motorized overhead doors are equipped with appropriate entrapment devices).

"Due diligence" is important as a legal defense for a person charged under occupational health and safety legislation. If charged, a defendant may be found not guilty if he or she can prove that due diligence was exercised. In other words, the defendant must be able to prove that all precautions, reasonable under the circumstances, were taken to protect the health and safety of workers. Manufacturer’s standards and recommendations can be used as determinants of what is “reasonable”, “prudent”, or “diligent”.

Sectional Overhead Doors

How They Work

Sectional doors are constructed of door “sections”, usually 24“ high, which are stacked one on top of the other, and fastened together with hinges. The door articulates as it opens and closes, with its path guided by rollers that travel in steel tracks secured to the building.

Sectional doors utilize a simple counterbalance system where the weight of the door is offset by the potential stored energy of a pre-wound torsion spring. The torsion spring helps rotate the torsion shaft and drums, which in turn spool the lifting cables (also attached to the door’s bottom brackets) to lift the door. The torsion assembly and related components are under extreme tension.

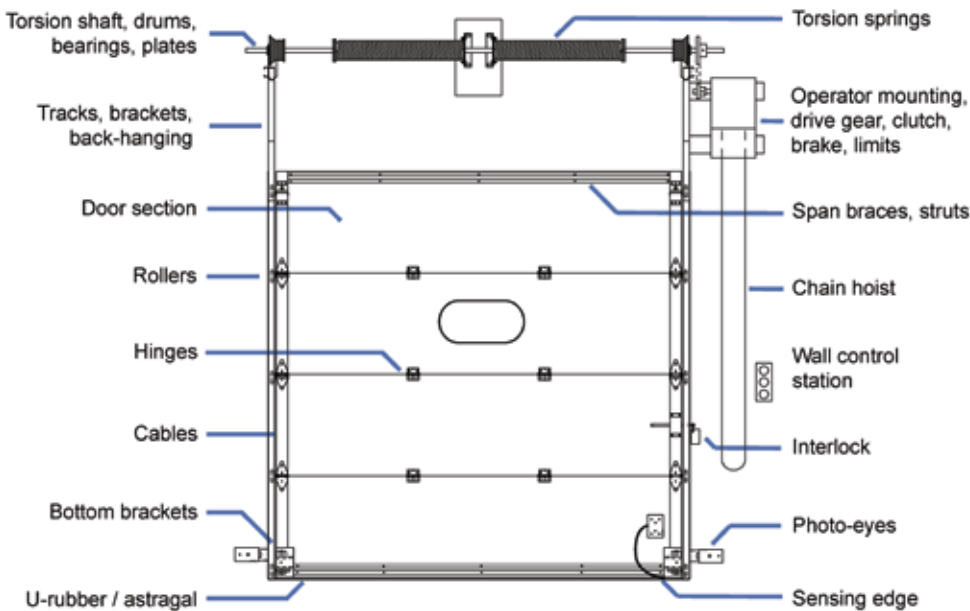

What You Need to Know

1. Many door components, such as hinges, bearings, cables and rollers, wear and fatigue with use, and require routine replacement. Left uncorrected, problems with smaller components can escalate into larger problems that affect the overall performance and safety of the door.
2. Sectional doors can become dangerous if the counterbalance system is compromised (eg. lifting cables break, become unspooled from the drums, or detach from the bottom brackets). If this occurs when the door is in an open position, the door can be at risk to fall.
3. There are several accessories available for sectional doors to improve safety: safety bottom brackets, spring failure safety devices, cable tension springs. Talk to your door dealer to learn more.

Components

Bottom brackets anchor the lifting cables to the door. They're under significant tension from the counterweight forces of the torsion springs, and it's important they be securely fastened to the door.

Cables support the entire weight of the door and are under tension from the torsion springs. Undersized or frayed cables can break, leaving one or potentially both sides of the door unsupported. It is common for cables to need replacing several times over a door's life.

Rollers guide the door in the tracks. It is common for rollers to wear and need replacing. Failed rollers can potentially impede the free movement of the door and cause it to jam in its tracks.

Tracks, brackets, back-hanging position and support the door to the building structure. Ceiling support of the tracks, called “back-hanging” is especially important as it supports the door in the fully open position.

Hinges connect the sections of the door and allow articulation. Poorly secured or aligned hinges can cause improper door movement and damage to sections or other parts of the door system.

Span braces and struts attach across the width of the door to provide lateral stiffness. Without proper span brace support, a door can be vulnerable to “bowing” or high wind conditions, both of which can cause a door to dislodge from its tracks.

Torsion springs provide the counterbalance force to the weight of the door and possess a large amount of stored mechanical energy. Broken torsion springs cause abnormal loading on door and electric operator components. Most torsion springs are rated for 10,000 cycles-to-failure and will likely need to be replaced at least once during a door's life. It is generally not possible to determine how many cycles are left in a torsion spring by visual inspection.

Torsion shaft, drums, bearings are the mechanical and structural components of the torsion assembly. Potential problems include: failed bearings, worn shafts, misalignments, loose couplers, improperly secured brackets, and cracked drums.

Pusher springs, bumper springs and stops prevent the door from running off the end of the tracks. Pusher springs are installed to maintain cable tension on certain door configurations.

Interlocks should be installed on doors with locks and motorized operators to prevent the operator from attempting to open the door when it is locked.

Rolling Steel Service Doors

How They Work

Rolling steel doors are constructed of many individual steel slats, usually 2-3" high, which attach to each other and create a continuous vertical "curtain." The curtain/slat assembly travels in channels in the door guides located on either side of the door, and "rolls" up into the head assembly, where it wraps around a barrel.

The weight of the curtain is counterbalanced by a torsion spring located inside the barrel. The balance of the door is adjusted using the tension wheel located at the end of the barrel assembly, which increases or decreases the tension on the spring.

Rolling steel service doors are often used in applications requiring greater security, where insulation value is not critical, or where there are space constraints.

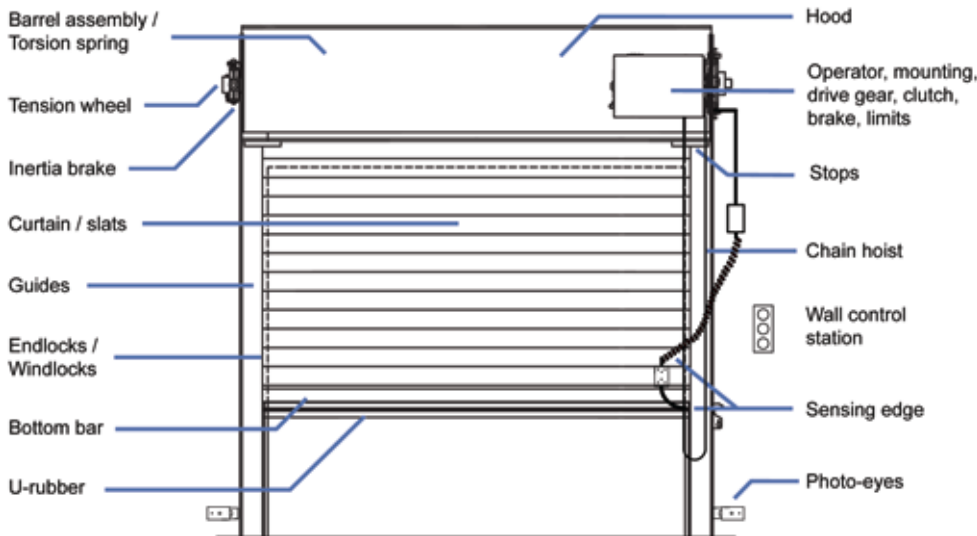

What You Need to Know

1. Torsion springs are a critical component of the door, and special care should be taken to ensure they are tensioned properly and replaced before they fail. Most torsion springs are designed with a lifespan 10,000 or 20,000 cycles, after which they become prone to failure. Implementing a program of proactive spring replacement can reduce operational disruptions related to "emergency" spring failures.
2. Safety inertia brakes can prevent the door from suddenly falling in the event of a torsion spring failure.

Components

Barrel assembly/torsion spring provide the counterbalance force to the weight of the door, lessening the force needed to open and close the door. The torsion spring is located inside the barrel assembly, limiting access and making visual inspections impractical. Torsion springs are typically rated 10,000 or 20,000 cycles-to-fail, making it important to track door usage to replace the spring before it fails.

Tension wheel is the component used to adjust the torsion springs balance. Adjusting the wheel will either increase or decrease tension on the door's torsion spring. The tension wheel is a direct connection to the torsion spring and possess a large amount of mechanical energy. If the tension wheel becomes loose or the mechanical connection to the spring is lost the operator will be subject to abnormal loading.

Inertia brake prevents the door from free falling by stopping the door's movement if a maximum RPM threshold is reached. Some inertia brakes work by communicating with the operator and some physically lock the shaft in place. Inertia brakes that physically stop the shaft can only be triggered so many times before needing replacement.

Endlocks/windlocks lock individual slats into the guides. Broken or loose endlocks can interfere with door movement by catching in the guides.

Stops physically prevent the door from running beyond the upper or lower limits. Stops are used along with limit switches to ensure the door does not overrun the guides.

Hood protects the curtain as well as shields moving components of the door from the elements. A damaged hood can interfere with the curtain and potentially damage it.

Guides are the channels in which the curtain moves. It is important the gap between guides is correct and the curtain is able to move freely. Obstructed movement due to damaged guides can exert an abnormal load on the operator.

Motorized Door Operators

How They Work

Because of their size and weight, many commercial overhead doors are equipped with motorized, electric operators. The most common type are “hoist” (or “jackshaft”) operators which mount near the torsion assembly, and open/close the door by rotating the torsion shaft.

Operators can be controlled by a variety of devices in a variety of ways: push button wall stations, remote control transmitters, timers, ground loops, etc. For convenience, many operators are programmed to close automatically (eg. timers), semi-automatically (eg. momentary pressure to close on a push button station), or by radio controls (eg. hand-held remotes). Doors operating in these modes create entrapment risk, and should be equipped with entrapment devices that reverse the door’s direction should it encounter an obstruction while it is closing.

Entrapment Devices

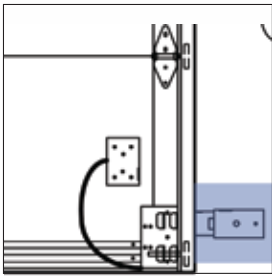
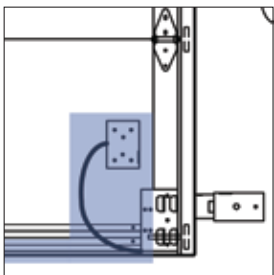

Photo-eyes emit a small light beam from a transmitter to a receiver across the width of the door opening at a height of 6” from the floor. If the light beam is interrupted when the door is closing, the operator reverses the door and holds it in a fully open position.

Photo-eyes can be “monitored” or “non-monitored” depending on their own capabilities and the capabilities of the operator. “Monitored” means the proper functioning of photo-eyes is frequently checked by the operator’s electronics, and should a problem be detected, the operator reverts to a “safe” mode restricting how the door can be closed. “Non-monitored” photo-eyes are not self-checking, and therefore offer a reduced level of safety.



Sensing edges are positioned on the bottom, leading edge of the door, and can detect physical contact with an object. If the sensing edge comes into contact with an object while the door is closing, a signal is sent to the operator to reverse the door to the fully open position.

Like photo-eyes, sensing edges can be “monitored” or “non-monitored” depending on their capabilities and those of the operator.

What You Need to Know

1. Entrapment devices are a critical safety component of motorized door systems. Their proper specification, installation and function are a core safety and compliance concern. Wherever reasonably practicable, doors should be equipped with “monitored” entrapment devices.
2. Modes of control affect entrapment device standards. The more “hands-off” the door’s operation (eg. automatic timer control), the higher the standard for entrapment devices.
3. All operator manufacturers call for (at a minimum) monthly checks of entrapment devices. These checks should be a routine part of your safety program.



About the Author

Garth Thomas is the President of Safedoor Planned Maintenance Ltd., a software company which provides planned maintenance and safety compliance software, called SafedoorPM, to the overhead door industry. SafedoorPM is used by door dealers and large organizations (eg. municipalities) to better perform, manage and record commercial maintenance and safety compliance work. www.safedoorpm.com

Footnotes

- ¹ Garage door crushed worker at Vancouver works yard not properly maintained - The Province, Oct 2012
- ² Jury awards \$21.3 million to man injured in garage door incident - IndyStar, Oct 2014.
- ³ Man pinned under garage door asphyxiated - Star Tribune, Mar 2012
- ⁴ Alberta Occupational Health and Safety Code, 2009, Part 3(12)(d)
- ⁵ *Occupational Health and Safety Act, Revised Statutes of Alberta 2000, Chapter O-2, Section 2(1)*

Disclaimer

The information in this publication does not take the place of professional occupational health and safety advice and is not guaranteed to meet the requirements of applicable laws, regulations, and rules. Safedoor Planned Maintenance Ltd., and their respective employees, officers, directors or agents (collectively "Safedoor") assumes no liability for or responsibility for any loss or damage suffered or incurred by any person arising from or in any way connected with the use of or reliance upon the information contained in this publication including, without limitation, any liability for loss or damage arising from the negligence or negligent misrepresentation of Safedoor in any way connected with the information contained herein. The information provided in this publication is on an "as is" basis. Safedoor does not guarantee, warrant, or make any representation as to the quality, accuracy, completeness, timeliness, appropriateness, or suitability of any of the information provided, and disclaims all statutory or other warranties, terms, or obligations of any kind arising from the use of or reliance upon the information provided, and assumes no obligation to update the information provided or advise on future developments concerning the topics mentioned.