



Jaipur Vidyut Vitran Nigam Limited
Office of the Superintending Engineer (Regulation)
Room No. 149, Old Power House Premises, Banipark, Jaipur-302016
प्रभास्मि शशिसूर्याय: Email- sermdf@jvvnI.org, Website: www.energy.rajasthan.gov.in/jvvnI
CIN: U40109RJ2000SGC016486

No: JVVNL/KUSUM-C/GRID-SPV/TN-04/2020 (Lot 1 to 10) /D. 1263

dated: 28/02/2020

Corrigendum/Revised Bid Document TN-04/2020 (Lot 1 to 10)

To,
All intending bidders

Subject: Corrigendum/Revised RFP of TN-04/2020 (Lot 1 to 10).

The Corrigendum/ Revised RFP is hereby issued in the already uploaded bidding documents of TN-04/2020 (Lot 1 to 10) regarding "**Design, Survey, Supply, Installation, Testing, Commissioning & 5 years Comprehensive Maintenance of distributed grid connected solar PV systems for solarization of grid connected agriculture consumers under "KUSUM Scheme – Component C" in JVVNL**". All intending bidders are requested to go through the Revised RFP and act accordingly while participating in the aforesaid bids. The revised RFP bidding document is being uploaded.

This is issued without prejudice to any other terms & conditions of subject bidding documents.

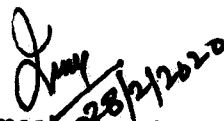
28/02/2020

(Umesh Gupta)
Superintending Engineer (Regulation)
Jaipur Vidyut Vitran Nigam Limited, Jaipur

Copy submitted / forwarded to the following for information & necessary action:

1. The Chief / Zonal Chief Engineer (PPM/KZ/BTPZ), Jaipur Discom, Jaipur / Kota / Bharatpur.
2. The Superintending Engineer (IT), Jaipur Discom, Jaipur with the request to host the procurement tender notice at Nigam's Website.
3. The TA / PA to Director (Technical / Finance), Jaipur Discom, Jaipur
4. The AO (Cash), Jaipur Discom, Jaipur.



(Umesh Gupta)
Superintending Engineer (Regulation)
Jaipur Vidyut Vitran Nigam Limited, Jaipur

REVISED TENDER DOCUMENT

**DESIGN, SURVEY, SUPPLY, INSTALLATION, TESTING,
COMMISSIONING & 5 YEARS COMPREHENSIVE
MAINTENANCE OF DISTRIBUTED GRID CONNECTED
SOLAR PV SYSTEMS**

FOR

**SOLARIZATION OF GRID CONNECTED AGRICULTURE
CONSUMERS**

UNDER

“KUSUM SCHEME – COMPONENT C”

IN



JAIPUR VIDYUT VITRAN NIGAM LIMITED

Corporate Identification Number (CIN): U40109RJ2000SGC016486

Office of the Superintending Engineer (Regulation)

Room No. 149, Old Power House Premises, Banipark, Jaipur-302016

TELEFAX: 0141-2209533, Email - sermdf@jvvn.org

Website: www.energy.rajasthan.gov.in/jvvn

NIT No: JVVNL/KUSUM-C/GRID-SPV/TN-04/2020 (Lot 1 to 10)

DISCLAIMER

The information contained in this tender document or subsequently provided to bidder(s), written or, verbal, by or on behalf of Jaipur Vidyut Vitran Nigam Limited (JVVNL) or any of its employees, is provided to bidder(s) on the terms and conditions of this tender document and its subsequent amendment(s).

This tender document is non-transferable and is neither an agreement nor an offer by JVVNL to the prospective bidders or any other person. The purpose of this document is to provide interested parties/bidders with information that may be required by them in the preparation of their bid for stated scope of work.

Although adequate care has been taken while preparing the Tender document, however, the bidders shall satisfy themselves that document is complete in all respects. If noticed, bidders shall intimate any discrepancy in the Tender document to office of the undersigned within 3 days from the date of issuance of the Tender document. If no intimation is received from the Bidders within the stipulated period, it shall be assumed that the Tender document is complete in all respects and fulfils the expectations of the Bidders.

JVVNL, its officers, employees and consultants have made best efforts to provide as accurate and reliable information as possible. However, before submitting their bids, the Bidders are expected to independently assess, verify and validate the information/data provided in the Tender Document.

JVVNL reserves the right to annul the bid process and/or reject any or all of the Bids submitted in response to this Tender Document at any stage without assigning any reasons whatsoever. In such cases JVVNL will refund the Bid Security and cannot be subjected to any liability whatsoever due to such rejection/cancellation.

JVVNL, its officers, employees and consultants have no responsibility for authenticity of the information/data hence shall not be held liable for any possible omission, misrepresentation, mistake or error in the information/data provided in the Tender Document and consequences thereof.

The Company also accepts no liability of any nature whether resulting from negligence or otherwise howsoever caused arising from reliance of any applicant upon the statements contained in this document.

JVVNL may modify, amend or supplement any aspect of this Tender document, including selection process and evaluation criteria, if deemed necessary by it or the same is required under Law. Further, JVVNL or its authorized officers reserve the right, without prior notice, to change the selection procedure and the delivery of information at any time before submission of bids without assigning any reasons thereof. However, such change shall be posted on Bidding Portal.

The bidder, regardless of the conduct or outcome of the Bidding Process, shall bear all its costs associated with or relating to the preparation and submission of its bid including but not limited to preparation, copying, postage, delivery fees, expenses associated with any demonstrations or presentations which may be required by JVVNL or any other costs incurred in connection with or relating to its bid.

LIST OF ABBREVIATIONS

1.	+	Plus (Addition)
2.	AC	Alternating Current
3.	ACP	Aluminium Composite Panel
4.	Ag.	Agriculture
5.	AM	Air Mass
6.	ASTM	American Society for Testing and Materials
7.	BOQ	Bill of Quantity
8.	BOS	Balance-of-System
9.	CEA	Central Electricity Authority
10.	CEIG	Chief Electrical Inspector of Rajasthan
11.	CERC	Central Electricity Regulatory Commission
12.	CMC	Comprehensive maintenance Contract
13.	DC	Direct Current
14.	DCR certificate	Domestic Content Requirement certificate
15.	DTR	Distribution Transformer
16.	DWC	Double Walled corrugated
17.	FF	Fill Factor
18.	HFL	High Flood Level
19.	HP	Horse Power
20.	IEC	International Electrotechnical Commission
21.	IEEE	Institute of Electrical and Electronics Engineers
22.	IoT	Internet of Things
23.	IP	Internet Protocol /Ingress Protection
24.	IPR	Intellectual Property Right
25.	IS	Indian Standard
26.	Isc	Short Circuit Current
27.	IST	Indian Standard Time
28.	kV	Kilo Volt
29.	kW	Kilo Watts
30.	kWp	Kilo Watt peak
31.	LoI	Letter of Intent
32.	LT	Low Tension
33.	MCB	Miniature Circuit Breaker
34.	MDAS	Meter Data Acquisition System
35.	MIS	Management Information System
36.	MMS	Module Mounting Structure
37.	MNRE	Ministry of New & Renewable Energy, Government of India
38.	MPPT	Maximum Power Point Tracker
39.	MW	Mega Watt
40.	NEC	National Electric Code
41.	NIT	Notice Inviting EOI Document
42.	NOCT	Normal Operating Cell Temperature
43.	OS	Operating System for Computer/server
44.	OEM	Original Equipment Manufacturer
45.	PAN	Permanent Account Number

Revised Tender document for solarization of grid connected agriculture consumers

46.	PCU	Power Conditioning Unit
47.	PID	Potential-induced degradation
48.	POC	Proof of Concept
49.	PSD	Performance Security Deposit
50.	PV	Photovoltaic
51.	PVC	Poly vinyl chloride
52.	RCCB	Residual Current Circuit Breaker
53.	RDBMS	Relational Data Base Management System
54.	REC Ltd.	Rural Electrification Corporation, Govt. of India
55.	RERC	Rajasthan Electricity Regulatory Commission
56.	RFID	Radio Frequency Identification
57.	RRECL	Rajasthan Renewable Energy Corporation Ltd.
58.	RTC	Real Time Clock
59.	RTPP Act 2012	Rajasthan Transparency in Public Procurement Act 2012 including any amendments issued thereto;
60.	RTPP Rules 2013	Rajasthan Transparency in Public Procurement Rules 2013 including any amendments issued thereto;
61.	SCADA	Supervisory Control And Data Acquisition
62.	SECI	Solar Energy Corporation of India
63.	SMB	Sub Miniature version B
64.	SNA	State Nodal Agency for Renewable Energy
65.	SPD	Surge Protection Device
66.	SPV	Solar Photo Voltaic
67.	STADD-Pro	Structural Analysis And Design Computer Program
68.	STC	Standard Testing Condition (“STC” shall mean Standard Testing Condition for solar cells and PV modules with air mass AM1.5, irradiance 1000W/ m2, and cell temperature of 25°C.)
69.	THD	Total Harmonic Distortion
70.	ToU	Time of Use
71.	TPI	Third-party inspection
72.	TPIA	Third-Party Inspection Agency’ appointed by Discom and / or MNRE as may be applicable
73.	UAT	User Acceptance Test
74.	UV	Ultra Violet
75.	-ve	Negative
76.	Vmp	Voltage at Maximum Power
77.	Voc	Voltage at Open Circuit
78.	W	Watt
79.	WO	Work Order
80.	Wp	Watt peak
81.	XLPE	Cross-linked Polyethylene

CONTENTS

SECTION - A: Introduction	1
SECTION - B: Key Definitions.....	3
SECTION - B: Key Bid Data	5
SECTION - C: Scope of Work.....	10
SECTION - D: Eligibility & Qualification	16
SECTION - E: Submission of Bids.....	21
SECTION - F: Bid Opening & Evaluation	28
SECTION - G: Award of Contract.....	37
SECTION - H: General Terms & Conditions	40
SECTION - I: Detailed Scope of Work and Technical Specifications.....	57
SECTION - J: Bid Submission Formats	84
SECTION - K: Formats Applicable	143
SECTION - L: Other Annexures	169

SECTION - A: INTRODUCTION

A.1. Background

- 1.1.1. Jaipur Vidyut Vitran Nigam Limited (JVVNL) is a public utility company under the Department of Energy, Govt. of Rajasthan and is holder of the distribution and retail supply business licenses in the State of Rajasthan (hereafter referred as “DISCOM”). The Distribution Company came in to existence on 19th July 2000 pursuant to the “Rajasthan Power Sector Reforms Transfer Scheme, 2000” and restructuring undertaken in the State under which the vertically integrated Electricity Board (Rajasthan State Electricity Board or RSEB) was unbundled and the power generation, transmission and distribution business was segregated to form 5 successor companies viz.
- a) Rajasthan Rajya Vidyut Utpadan Nigam Limited (RVUN) to manage the electricity generation business of erstwhile RSEB
 - b) Rajasthan Rajya Vidyut Prasaran Nigam Limited (RVPN) to manage the electricity transmission and bulk supply business of erstwhile RSEB.
 - c) Ajmer Vidyut Vitran Nigam Limited (JVVNL) to manage the electricity distribution and retail supply business of erstwhile RSEB in Ajmer City Circle, Ajmer District Circle, Bhilwara, Nagaur, Jhunjhunu, Sikar, Udaipur, Chittorgarh, Rajsamand, Banswara, Pratapgarh and Dungarpur Circles.
 - d) **Jaipur Vidyut Vitran Nigam Limited (JVVNL)** to manage the electricity distribution and retail supply business of erstwhile RSEB in Alwar, Bharatpur, Jaipur City, Jaipur District, Dausa, Kota, Jhalawar, Sawai Madhopur, Bundi, Baran, Tonk, Karauli and Dholpur Circles.
 - e) Jodhpur Vidyut Vitran Nigam Limited (JDVVNL) to manage the electricity distribution and retail supply business of erstwhile RSEB in Sriganganagar, Hanumangarh, Churu, Bikaner District, Bikaner City, Jaisalmer, Jalore, Barmer, Jodhpur City, Jodhpur District, Sirohi, Jalore, and Pali Circles.
- 1.1.2. In February 2019, Government of India launched Pradhan Mantri Kisan Urja Suraksha evam Utthaan Mahabhiyan (KUSUM scheme) with the objective of financial and water security to farmers.
- 1.1.3. Individual farmers having grid connected agriculture pump will be supported to solarise pumps. The farmer will be able to use the generated solar power to meet the irrigation needs and the excess solar power will be sold to DISCOM.
- 1.1.4. It will help DISCOMS to reduce the subsidy burden as well as meet their RPO targets
- 1.1.5. The Ministry of New & Renewable Energy, Government of India vide OM F. No. 32/645/2017-SPV Division dated 22.07.2019 issued operational guidelines for implementation of Pradhan Mantri Kisan Urja Suraksha Evam Uttan Mahabhiyan Scheme (KUSUM). Under Component C, solarisation of 10 lakh grid connected agriculture pumps of individual pump capacity up to 7.5 HP is targeted across India.
- 1.1.6. Modality to be adopted for KUSUM Component C implementation in **Rajasthan DISCOMs**, shall be based on Net-metering arrangement, where the agriculture pump will continue to run at rated capacity taking power from solar panels and balance power from grid, if required, and in case solar power generation is higher than required by pump, the additional solar power would be fed to the grid. **In case of non-**

availability of power from grid, the pump should be able to run taking power from solar panels while avoiding any power supply to the grid (suitable arrangement is to be made by the contractor in this regard).

1.1.7. Key benefits of KUSUM scheme:

- a) DISCOM will save on recurring deficit by low agriculture tariff.
- b) Farmers will receive reliable day time power.
- c) Farmers can sell excess power to Grid and increase their income
- d) Farmers will be incentivised to conserve energy as well as ground water.
- e) No additional Electric load on the grid for Agriculture Pumps.

A.2. Objective

- 2.1.1. JVVNL intends to select competent, experienced and eligible bidders for the work of design, survey, supply, installation, testing, commissioning & 5 years comprehensive maintenance of distributed grid connected solar PV systems for solarization of grid connected agriculture consumers under “KUSUM Scheme – Component C” in Jaipur Discom on selected agriculture feeders (as per technical specifications as prescribed).
- 2.1.2. The list of agriculture consumers where such solar systems are to be installed will be made available to the bidders before award of work.

A.3. Mode of Execution of Programme

- 3.1.1. The basis of evaluation of the bids shall be the cost/rate quoted in the Price Schedule. To further clarify, all the costs including applicable taxes, duties, etc. pertaining to design, survey, supply, installation, testing, commissioning & 5 (five) years comprehensive maintenance of the said complete SPV systems shall be inclusive in the Price Bid quoted by Bidders for the purpose of comparison and evaluation. Bidders are required to quote rate / cost on firm basis and no price variation on any account shall be considered.
- 3.1.2. The work is to be carried out on a ‘Turn Key Basis’. **The estimated quantity of solar systems covered under this Tender will be around 6,367 Nos distributed on 121 selected feeders of Jaipur Discom. This quantity may further increase up to 50% and decrease as required by Discom.**
- 3.1.3. The contractor shall be provided the list of agriculture connections/ beneficiaries covered under the scope of work under this tender.
- 3.1.4. The contractor shall also be required to set up their repair and maintenance centres for providing effective repair/maintenance services to the beneficiaries and meet conditions detailed in SECTION - I:

SECTION - B: KEY DEFINITIONS

B.1. Definitions

1.	“JVVNL” / “Jaipur Discom”	Jaipur Vidyut Vitran Nigam Limited, Jaipur
2.	Rajasthan Discoms	All 3 Discoms in Rajasthan namely: JVVNL, AVVNL & JdVVNL
3.	Manufacturers:	Manufacturers of SPV Systems (meeting technical specification as per guidelines of MNRE).
4.	NIT / Tender Document	Notice Inviting Tender / “Tender Document” / shall mean this “Notice Inviting Tender for the work of design, survey, supply, installation, testing, commissioning & 5 years comprehensive maintenance of distributed grid connected solar PV systems for solarization of grid connected agriculture consumers under “KUSUM Scheme – Component C” in Jaipur Discom Basis in response to NIT No. JVVNL/KUSUM-C/GRID-SPV/TN-04/2020 (Lot 1 to 10).
5.	SPV System:	“SPV System” shall mean the grid-connected Solar PV system as per Tender Document that shall be supplied, installed, commissioned and maintained with all other ancillary required by the Contractor for satisfactory operation of the SPV System. It shall mean the Grid-tie Solar Photo-Voltaic (PV) system including the PV modules, grid-tie inverter(s), SPV controller, module mounting structure(s), cables and connectors, safety and earthing equipment, interconnection equipment, and inverter with remote monitoring with other components for Solarization of Agriculture pump sets of Agriculture Consumers that shall be supplied, installed, commissioned and maintained by the Contractor.
6.	Bid:	shall mean the “Proposal” / “Quotation” submitted by eligible bidders for the work of design, survey, supply, installation, testing, commissioning & 5 years comprehensive maintenance of distributed grid connected solar PV systems for solarization of grid connected agriculture consumers under “KUSUM Scheme – Component C” in Jaipur Discom in response to NIT No. JVVNL/KUSUM-C/GRID-SPV/TN-04/2020 (Lot 1 to 10).
7.	Bidder:	Shall mean an entity submitting the Bid. Any reference to the Bidder includes an entity including its successors, executors and permitted assigns severally, as the context may require
8.	CMC:	Comprehensive Maintenance Contract
9.	Beneficiary:	“Agriculture Consumer” / Owner of Agriculture Connection which is going to be solarized under this tender.

Revised Tender document for solarization of grid connected agriculture consumers

10.	Contractor:	shall mean the successful Bidder whose Bid to perform the Contract as per this Tender Document has been accepted by JVVNL, Project is awarded by the Jaipur Discom and is named as such in the Contract Agreement, and includes the legal successors or permitted assigns of the Contractor; At multiple places terms such as “Seller”/ “Supplier” are used shall be meaning Contractor/ Bidder as applicable.
11.	Scheme:	KUSUM Scheme – Component C launched by MNRE, GoI
12.	Contract/ Agreement	Contract shall mean the contract signed between the Discom and the Contractor to execute the entire Scope of Work as given in this Tender Document;
13.	Discom	Shall mean Jaipur Vidyut Vitran Nigam Limited (JVVNL), unless specifically name of Discom is mentioned. At multiple places terms such as “Purchaser”/ “Employer”/ “Procuring Entity” are used to refer to Jaipur Discom.
14.	Project:	Work of design, survey, supply, installation, testing, commissioning & 5 years comprehensive maintenance of distributed grid connected solar PV systems for solarization of grid connected agriculture consumers under “KUSUM Scheme – Component C” in Jaipur Discom in response to NIT No. JVVNL/KUSUM-C/GRID-SPV/TN-04/2020 (Lot 1 to 10).
15.	“Solarization”	“Solarization” shall mean to connect the existing grid-connected Agriculture Consumer pump-sets of farmer to the distributed, renewable energy source of Solar by installing Grid connected SPV system of the required capacity in the farmer’s premises (i.e. farm) as per the Tender Document terms and condition.
16.	“Successful Bidder”	The Bidder who has been issued LOI by JVVNL.
17.	Guaranteed CUF	Shall be 15% calculated with respect to the AC capacity of the PV plant. CUF in a Year shall mean the ratio of the output of the SPV Power Plant in a Year versus installed Project capacity x 365 x 24. (CUF = Cumulative Project output in kWh / (installed Project capacity in kWp x 24 x 365))
18.	Engineer In-charge	As designated by Discom
19.	Nodal Officer	Senior Engineer as designated by Discom
20.	Payment Officer	Officer from Accounts Wing designated by Discom
21.	Authorized Officer	Officer Designated by Discom for specific task
22.	Electrical Inspectorate	Electrical Inspectorate Department Rajasthan

SECTION - B: KEY BID DATA

i.	NIT No:	JVVNL/KUSUM-C/GRID-SPV/TN-04/2020 (Lot 1 to 10)
i.	NIT Issue Date	30.01.2020
ii.	Programme & detail of work / “Project”	Design, survey, supply, installation, testing, commissioning & 5 years comprehensive maintenance of distributed grid connected solar PV systems for solarization of grid connected agriculture consumers under “KUSUM Scheme – Component C” in Jaipur Discom
iii.	Work Area: / “Site”	121 No. Feeders of Jaipur Discom, as provided in SECTION - C:(1.1.4).
ii.	Estimated Nos. of Solar Systems to be installed	6,367 Nos. (Tentative - Quantity may increase/decrease) distributed in 121 Feeders
iii.	Total Estimated Project Cost:	Rs. 245.65 Crores
iv.	Bid Security:	2% of Estimated cost of the lot (lot wise value mentioned in table given below) In case a bidder is quoting for more than one Lot, bid security shall be sum of Lot wise bid security of all quoted Lots. (in case of SSI units please see SECTION - B:(1.1.3)
v.	Date of downloading	30.01.2020 from 06:00 PM {The tender can be downloaded from Bidding Portal}
vi.	Last Date of online submission of Bid (Cover-1, Cover-2 & Cover-3)	18.3.2020, 01:00 PM
vii.	Date of Opening of online Technical bid (Cover-1 & Cover-2)	19.3.2020, 03:00 PM
viii.	Date of opening of Financial bid of eligible & qualified bidders (Cover-3)	Shall be intimated after evaluation of Technical bid.
ix.	Date of Completion of work.	Within 9 months from date of issue of LOA and thereafter 5 years of AMC (Refer SECTION - C:(1.1.6) of tender document for details)
x.	Cost of Tender Document:	As mentioned in table given below (Rs. 2,950 per lot inclusive of GST) Cost of tender document should be in favour of payable at A.O. (MM), JVVNL, Jaipur. In case a bidder is quoting for more than one Lot, cost of tender document shall be sum of Lot wise cost of tender document of all quoted Lots.
xi.	E-procurement processing Fees:	As mentioned in table given below (Rs 1,180 per lot inclusive of GST). Cost of e-procurement processing fees should be in favour of MD RISL, payable at Jaipur. In case a bidder is quoting for more than one Lot, e-procurement processing fees shall be sum of Lot wise e-

Revised Tender document for solarization of grid connected agriculture consumers

		procurement processing fee of all quoted Lots.
xii.	Bid Validity	6 months from the date of opening of online Technical bid.
xiii.	Bidding Portal	www.eproc.rajasthan.gov.in
xiv.	Pre-bid meeting	07.2.2020, 05:00 PM

S. No.	Lot	Lot Name	Estimated Cost	EMD / Bid Security	Cost of tender document (inclusive of GST)	e-procurement processing fees (inclusive of GST)
			INR Crores	INR Lakhs	INR	INR
1	TN-04/2020 (Lot 1)	Jhalawar - 1	22.24	44.48	2,950	1,180
2	TN-04/2020 (Lot 2)	Jhalawar - 2	23.95	47.90	2,950	1,180
3	TN-04/2020 (Lot 3)	Jhalawar - 3	23.99	47.98	2,950	1,180
4	TN-04/2020 (Lot 4)	Tonk – 1	29.93	59.87	2,950	1,180
5	TN-04/2020 (Lot 5)	Tonk – 2	28.92	57.85	2,950	1,180
6	TN-04/2020 (Lot 6)	Tonk – 3	25.44	50.88	2,950	1,180
7	TN-04/2020 (Lot 7)	SWM – 1	19.44	38.88	2,950	1,180
8	TN-04/2020 (Lot 8)	SWM – 2	23.79	47.59	2,950	1,180
9	TN-04/2020 (Lot 9)	Kota, Baran	16.59	33.19	2,950	1,180
10	TN-04/2020 (Lot 10)	Alwar, JPDC	31.36	62.73	2,950	1,180

NOTE: Bids are to be submitted online in electronic format on Bidding Portal with scanned copies of all required documents. Documents regarding Bid Security, Cost of Tender Document and RISL E-procurement processing Fees to be submitted in physical form as detailed in subsequent clauses. One hard copy of technical bid also to be submitted before the scheduled date & time.

1.1.1. The bidders are requested to submit their bids prior to scheduled date & time to avoid event of non-submission of their bids due to non-availability / hanging of Bidding portal, at either ends, at last moment or any reason whatsoever. The last date of submission of bids will not be extended in such circumstances.

1.1.2. The Bid Security, Cost of Tender Document and RISL E-procurement processing Fees, is to be deposited in Envelope-1(in Physical/ Hard Form) at Office of Superintending Engineer (Regulation) JVVNL, Jaipur prior to scheduled date & time as mentioned in SECTION - B: Point (vi) and the scanned copy of proof of deposit/ receipt of these documents be uploaded on Bidding Portal in Cover-1 as mentioned in SECTION - B: Point (vi). Both hard copy submission and online submission of

scanned copies as prescribed is essential otherwise the bid (Technical Bid (Cover-2 & Financial Bid (Cover-3)) in electronic form will not be opened of that bidder.

1.1.3. The bidder shall have to submit the desired documents in the following manner:

a) **Envelope-1:** i.e.:

- i. The DD/Banker's Cheque only of prescribed cost of Tender document as mentioned in SECTION - B: Point (x) in favour of **A.O. (MM), JVVNL, Jaipur payable at Jaipur;**
- ii. The DD/Banker's Cheque only of prescribed processing fee of RISL as mentioned in SECTION - B: Point (xi) in favour of **MD RISL, payable at Jaipur;** and
- iii. Bid security of prescribed value as mentioned in SECTION - B: Point (iv) by way of
 1. DD/Banker's Cheque/ in favour of **A.O. (MM), JVVNL, Jaipur payable at Jaipur**

OR

2. Bank Guarantee ("BG") in favour of Superintending Engineer (Regulation) JVVNL, Jaipur. The BG shall be from Any Government bank and in case of private bank as enlisted below:

Sl. No.	Name of Banks
1.	HDFC Bank Ltd.
2.	Axis Bank Ltd.
3.	Kotak Mahindra Bank Ltd.
4.	Federal Bank Ltd.
5.	Indusind Bank Ltd.
6.	Development Credit Bank Ltd.
7.	ING Vysya Bank Ltd.
8.	Karnataka Bank Ltd.
9.	Karur Vysya Bank Ltd.
10.	Ratnakar Bank Ltd.
11.	South Indian Bank Ltd.
12.	Yes Bank Ltd.
13.	ICICI Bank
14.	IDFC Bank

- iv. A Certificate of Registration under DIC's in Rajasthan shall require to be submitted in proof of SSI unit of Rajasthan for getting benefit of exemption in submission of Bid Security.

Government undertakings PSUs are exempted from submission of Bid Security on producing certificate issued by competent authority. As per RTPP Act 2013, Rule 42 (2) in case of open competitive bidding, two-stage bidding, rate contract, electronic reverse auction, bid security shall be 2% or as specified by the State Government of the estimated value of subject matter of procurement put to bid. **In case of small-scale industries of Rajasthan it shall be 0.5%** of the quantity offered for supply and in case of sick industries, other than small scale industries, whose cases are pending with Board of Industrial and Financial Reconstruction,

it shall be 1% of the Estimated cost of the lot(s). Concessional bid security may be taken from registered bidders as specified by the State Government. Every bidder, if not exempted participating in the procurement process shall be required to furnish the bid security as specified in the tender document.

For claiming the above benefit an affidavit on Rajasthan Non-Judicial Stamp Paper of Rs. 100/- (as per SECTION - J: Format J.2) and SSI Certificate from Govt. of Rajasthan need to be submitted in the envelope no. 1.

- v. Bid security shall remain valid for a period of thirty (30) days beyond the original bid validity period, and beyond any extension subsequently requested. In case of submission of the Bid Security in form of Bank Guarantee (BG), bid security shall be submitted in standard format as per **SECTION - J: Format J.1**
- 1.1.4. Cutting / overwriting if any in the figures of the tendered documents is required to be clarified / indicated in words, duly signed, failing which the tender may be rejected.
- 1.1.5. Deviation of any kind is “not” to be quoted in the bid. Such deviations shall not prevail.
- 1.1.6. The bidders shall provide complete information at the time of submission of bid. If the bidders are asked to furnish some more clarification/confirmation/document, they shall be required to furnish the same within specified time, failing which the case shall be finalized /decided on the basis of available information/documents. The responsibility of ignorance of their bid on account of delay in furnishing of desired information/documents shall be of the bidder. However, if there are any shortcomings in the submission of the information which not materially affects the qualification criterion, then JVVNL shall have the power to consider the facts on the merit of the case and decide the bid evaluation accordingly.
- 1.1.7. **All tender documents shall essentially be signed digitally and submitted / uploaded on Bidding Portal in time specified SECTION - B:.**
- 1.1.8. The Bidder shall submit the Techno Bid in hard copy also marked as Bid Envelope (Technical Part) containing the documents. These envelopes shall then be sealed in an outer envelope.
- 1.1.9. Bidders who wish to participate in this tender, will have to register on Bidding Portal (bidders registered earlier on the Bidding Portal need not to get registered again). To participate in online tenders, Bidders will have to procure Digital Signature Certificate (Class II & Class III) as per requirement under Information Technology Act-2000 using which they can sign their electronic bids. Bidders can procure the same from any CCA approved certifying agency or they may contact e-Procurement Cell, Department of IT & C, Government of Rajasthan on the address **e-Procurement Cell, RISL, Yojana Bhawan, Tilak Marg, C-Scheme, Jaipur, e-mail: eproc@rajasthan.gov.in**
- 1.1.10. Bidders are also advised to refer “Bidders Manual” available under “Downloads” section on Bidding Portal for further details about the e-tendering process.
- 1.1.11. All the required information shall be furnished strictly in the prescribed Formats only. Any information indicated other than the prescribed Formats shall not be entertained. The bid shall be evaluated on the basis of information furnished in the prescribed Formats only.

1.1.12. Clarifications regarding this tender document for any type of typographical Errors or misunderstanding of document, the version/decision of JVVNL shall be final.

1.1.13. Pre-bid Meeting

- a) Pre-bid Meeting shall be conducted on 07.02.2020 at 5 PM in Conference hall at Corporate Office of JVVNL at Jaipur, Rajasthan on the scheduled date and time as mentioned in SECTION - B: Point (xiv) at the following address:

Conference hall, Vidyut Bhawan, Near Vidhan Sabha, Jaipur.

1.1.14. Correspondence for enquiries and clarifications

All correspondence in respect of this tender and submission of the Tender shall be addressed to:

The Superintending Engineer (Regulation)
Jaipur Vidyut Vitran Nigam Limited (JVVNL)
Room No. 149, Old Power House Premises, Banipark, Jaipur-302016
TELEFAX: 0141-2209533
Email- sermdf@jvvn.org

SECTION - C: SCOPE OF WORK

- 1.1.1. Scope of work under this tender covers design, survey, supply, installation, testing, commissioning & 5 years comprehensive maintenance of distributed grid connected solar PV systems for solarization of Agriculture Pumps, with individual pump capacity up to 7.5 HP, under “KUSUM Scheme – Component C” in Jaipur Discom.
- 1.1.2. The scope shall be limited to selected agriculture feeders under the jurisdiction area of Jaipur Discom, conforming to detailed scope & technical specifications enumerated in SECTION - I: of this Tender document.
- 1.1.3. Summary scope of work is provided hereunder:

a) Work of installation of SPV System shall involve:

- 1.1. Entering into Contract agreements with Discom and Agreements with the concerned Agriculture Consumer.
- 1.2. Completion of work of design, survey, supply, installation, commissioning and testing as per time schedule. Survey shall include assessing the works/approvals required on the Sites/ location of the list of agriculture consumers which will be provided by Discom.
- 1.3. For effective management of the project, **feeder-wise implementation** is to be carried out for solarisation of grid connected agricultural pumps. Feeders may be selected based on load, technical and commercial losses, number of consumers, etc. Contractor shall ensure that all identified sites of agriculture pumps (as per the work area / site locations listed in this tender) in a feeder are solarized before proceeding the work on to the next feeder.
- 1.4. Contractor will essentially provide the verified documents (from Discom after physical verification of installations) along-with location coordinates (Longitude and Latitude of agriculture connection where system installed) on Discom website as per directions before submission the claims for payment. Verified copies of statements of GPS coordinates shall be submitted to Nodal Officer of Discom every fortnightly-basis.
- 1.5. The Contractor shall be allowed to install the systems conforming to the technical specifications (as per specifications detailed at SECTION - I:) with submission of type test certificates (not older than five years) of SPV system issued from “MNRE approved test house” / “any Government recognized lab” / “**international labs**” after authorisation by Discom.

b) Work of ongoing maintenance of SPV System shall involve:

- 1.1. Jaipur Discom gives great importance to comprehensive maintenance of the systems & it is felt that without proper maintenance after installation of system, consumers may be deprived of the benefits of this Scheme. To achieve this objective, contractor shall proceed to first establish office-cum-service centre in each operational district for installation of systems with a helpline in local language.
- 1.2. Contractor shall be bound to provide after sales service to the beneficiaries in the vicinity of the area of the installed systems or at least at tehsil level /at district to facilitate CMC services.

- 1.3. The beneficiaries must be well informed about the CMC centre of the Contractor, call centre/toll free numbers. This may consist of office-cum-service centre at a convenient place to be reached by a beneficiary. Such office-cum-service centres shall have spares for the system and repair facility.
- 1.4. The Concerned Nodal officer of Discom shall verify this fact and only then Contractor shall be allowed to install the systems.
- 1.5. The Contractor will educate the Beneficiaries on the process for registering the complaints on Call Center/toll free nos. The details of office-cum-service centers along with telephone numbers & contact persons of firm & details of Discom offices, address and telephone numbers must be provided to each beneficiary. Beneficiaries shall also be educated through brochures about do's & don'ts on the system.
- 1.6. The contractor will update the status of fault rectification on Discom website /call centre for online monitoring of the complaints registered and services being provided by the Contractor.
- 1.7. Cleaning of dust from SPV Panel shall be in scope of the contractor.

1.1.4. Tentative Quantity

The tentative estimated quantity of each SPV System to be executed under this tender are as provided below:

Lot	Lot name	No. of 11kV feeders	No. of agricultural consumers with sanctioned load of			
			3 hp	5 hp	7.5 hp	Total
1	Jhalawar - 1	15	104	562	23	689
2	Jhalawar - 2	14	1	367	228	596
3	Jhalawar - 3	5	33	628	42	703
4	Tonk - 1	16	14	829	33	876
5	Tonk - 2	18	5	770	56	831
6	Tonk - 3	9	3	263	326	592
7	Sawai Madhopur - 1	5	-	-	384	384
8	Sawai Madhopur - 2	11	-	-	470	470
9	Kota, Baran	11	97	222	141	460
10	Alwar, JPDC	17	13	416	337	766
TOTAL		121	270	4,057	2,040	6,367

Note: (1) This quantity may further increase up to 50% or decrease as required by Discom.

(2) Farmers may be given option to declare his actual connected load or alternatively the contractor may carry out survey to get details on actually connected load so that solar PV panels of required capacity is provided to the participating farmers.

1.1.5. Site Details

The Project Sites shall be the agriculture farm lands of the Agriculture Consumers of Discom where the grid-connected Agriculture connection is issued by Discom for grid-connected pump-set. The list of such consumers where grid-connected SPV systems are to be installed & commissioned to solarize such connections shall be

Revised Tender document for solarization of grid connected agriculture consumers

provided by Discom. Such agriculture consumers are located on the following feeders in JVVNL:

Lot	Circle Name	Name of 33/11kV substation	Name of 11kV Feeder	No. of pumps with capacity of			
				3 hp	5 hp	7.5 hp	Total
Lot 1	Jhalawar	CHANDIPUR	PACHHETA-R	4	57	2	63
		CHHAN	GHARAWALI-R		44	1	45
			JAWARI-R	4	30		34
		GHATOLI	SARDA R	15		14	29
		KAMKHERA	KAMKHERA-R	3	26	1	30
			SULIYA-R	5	50		55
		KATFALLA	AMETHA -II	7	66		73
			THANAWAD	7	30		37
		KHATAKHERI	KHATAKHERI		21	1	22
		KHAZOORI	KHAZOORI-R		37	1	38
		M. THANA	GARBOLIYA	2	20		22
		MAITHOON	METHOON	13	49	2	64
			THAROL	24	49	1	74
Manoharthana	MAHARAJPURA OLD-R	2	54		56		
RANIPURIYA	MAHUWAKHEDA	18	29		47		
TOTAL				104	562	23	689
Lot 2	Jhalawar	BHILWARI	BHILWARI-II (BUS STAND) U		23	68	91
		BOOD MANDAWAR	MANDAWAR R	1	13	34	48
		DUG	DHUDHALIYA		83	1	84
		DURGPURA	DURGPURA R		5	14	19
		J. ROAD	PACHYAKHEDI R		9	28	37
		KHARPA KALAN	GELANI_KHARPA		43	1	44
		KYASARA	GUNAI		23		23
		PAGARIYA	DEVGARH_PAGARIYA		59	2	61
			PYARA		57		57
		PIPALIYA KHURD	BHESAJAR		32		32
		RALAYATA	Undal		6	30	36
		ROOPARAIL	MANDAWAR R		1		1
		SALOTIYA JWR	SAHIPUR R		4	28	32
		SAMRAI	SINGHANIYA R		9	22	31
TOTAL				1	367	228	596
Lot 3	Jhalawar	DEEWALKHEDA	SEMALI BHAWANI R	2	68		70
		DOONGERGAON	MALATOTA R	9	38	1	48
		RAIPUR	DAWAL R	13	311	9	333
		SALRI SEMLI	NAYAPURA_1032951	2	59	30	91
			SALRI SEMLI	7	152	2	161
TOTAL				33	628	42	703
Lot 4	Tonk	Aanwa	SITAPURA	4	56		60
		Banthali	SANTHALI	1	81		82
		BAWDI	PANDRAHEDA		20	4	24

Revised Tender document for solarization of grid connected agriculture consumers

Lot	Circle Name	Name of 33/11kV substation	Name of 11kV Feeder	No. of pumps with capacity of			
				3 hp	5 hp	7.5 hp	Total
		Bhansu	THADOLI	4	116	1	121
		DEWADAWAS	DEWADAWAS		108	1	109
		Dhua kala	GEROLI		25	2	27
		Ganwadi	GANWADI		24		24
			GANWDI 2	3	19		22
		Gurai	GURAI-2	1	108	6	115
		JUNIYA	JUNIYA	1	58		59
		NAGARFORT	GURAI-1		53	7	60
			NAGARFORT		21		21
			RAMSAGAR		26	1	27
			SAKRAMPURA		67	10	77
		NASIRADA	MALEDA		17		17
		Todaraisingh	BASSI		30	1	31
		TOTAL				14	829
Lot 5	Tonk	Arniyamal	SONVA		30		30
		BANWADA	JAIKISHANPURA		17		17
		Chainpura	BAORI		26	1	27
		CHHAN	CHHAN_1006540		46	1	47
		Deoli banchi	NATWADA		29	6	35
		Dodwadi	GAHLOD		15	2	17
		Ghas	LAWADAR		24	2	26
		Jhirana	SANDHEDA		53	3	56
		Mehndwaas	AMINPURA		92	12	104
			MEHANDWAS NADI		25		25
		Mohammadpura	HARCHADEDA		56	8	64
		NOHATA	NOHATA	2	88	8	98
		PACHEWAR	MALIKPUR		17	1	18
		Railway station Niwai	ROOPWAS		83	6	89
		RANOLI	CHOGAI		41	5	46
		Sohela	HADI KALAN		20	1	21
			KAKRAJ KALAN		21		21
		SURYA	SURYA	3	87		90
TOTAL				5	770	56	831
Lot 6	Tonk	Choru	MOLVI NAGAR		5	28	33
		Khijuri	PANCHOLAM		5	28	33
		Phuleta	Kakod		4	13	17
		Pilai	BOSARIYA		26	55	81
			RAIPURA		22	30	52
		STATE TENNERIES TONK	SORAN	3	74	17	94
		Sureli	SURELI-2		95	21	116
		UNIARA	NAHARA		9	55	64
			UNIARA CITY -I		23	79	102
TOTAL				3	263	326	592
Lot 7	Sawai Madhopur	BARNALA	TIGARIYA			22	22
		CHHARODA	JAMULKHEDA			72	72
		KUNDERA	ULIYANA			81	81
		NINARDADA	SYAMOTA			46	46
		SYAMPURA	GANGI			163	163

Lot	Circle Name	Name of 33/11kV substation	Name of 11kV Feeder	No. of pumps with capacity of				
				3 hp	5 hp	7.5 hp	Total	
		TOTAL		-	-	384	384	
Lot 8	Sawai Madhopur	BHADOTI	RASULPURA			31	31	
			SHESHA			59	59	
		BONLI	GALAD			21	21	
			PIPALDA-RURAL			37	37	
		BOREKHEDA	BAPUI			33	33	
		GOTOD	PILUKHEDA			64	64	
		KODIYAE	KODIYAE			23	23	
		KOLADA	THADOLI			61	61	
		KUSALIPURA	KUAGEOV			61	61	
		MITRAPURA	MITRAPURA			31	31	
		PEEPLALWADA	BAGDOLI			49	49	
		TOTAL		-	-	470	470	
Lot 9	Baran	GEHUKHEDI	BAPCHA	2	22	19	43	
		KADIYACHOR	FALIYA		13	9	22	
		MAJARAWATA	MAJARAWATA			49	49	
		MUNDALA	MAL BAMORI		9	10	19	
		PALI	DHIGARADI	11	10	11	32	
	Kota	BHUDADHEET	BANETHIYA		33	7	40	
		KOTRADEEPSINGH	KOTRA DEEPSINGH		2	2	4	
			KOTRADEEPSINGH		18	15	33	
		RAWALI	BHAVPURA	84	95	1	180	
		SANMANPURA	HATHOLI		11	9	20	
			NEEMSARA		9	9	18	
			TOTAL		97	222	141	460
	Lot 10	Alwar	Tehla	Tehla City		2	80	82
JPDC		12 MILE	12 MIEL		22	19	41	
			BASDI	1	22	5	28	
			BEELVA	3	34	3	40	
		33 KV SHIVDASPURA	TITARIYA	6	101	42	149	
		Ajrajpura	Ajrajpura			24	24	
			Hasampura		15	11	26	
		Dyodi	Mundwara		5	47	52	
		JHAG	GANGATI	1	49	7	57	
			SAWLI	1	34	24	59	
		MOHABBATPURA	MOHABBATPURA		26	14	40	
		Ramjipura	Salhadi pura		12	4	16	
		RENWAL	HARSULIYA		41	6	47	
			KALI KOTI		22	5	27	
		SHYAMPURA	CHANDAWAS	1	16	18	35	
		SINODIYA	PANIHARI		12	26	38	
WATIKA	BASDI		3	2	5			
		TOTAL		13	416	337	766	
GRAND TOTAL				270	4,057	2,040	6,367	

1.1.6. Completion Period

- a) The design, survey, supply, installation, testing, commissioning of distributed grid connected SPV systems for solarization of grid connected agriculture consumers as

per terms & conditions of this Tender Document is to be completed within 9 (nine) months from date of Letter of Award. The following completion schedule shall be followed:

- i. Commencement Period: One month from date of award of work (LoA) which will include material & labour mobilization with survey, design & approvals and submission of feeder-wise consumer list with their consent for solarization of water pumps.
 - ii. In next 8 months, completion of all the required scope of work pertaining to design, survey, supply, installation, testing, commissioning of distributed grid connected SPV systems for solarization of grid connected agriculture consumers as per terms & conditions of this Tender Document.
 - iii. Further, the Contractor has to start and operationalize the Office-cum-service center for ongoing maintenance and registration & rectification of faults, within 2 months from the date of issue of LOI.
- b) Discom may extend the completion period at its discretion. However, in any case, the total extension to the completion period will not be more than six months.
- c) The time specified for work in the contract is important essence of the contract and the contractor shall arrange to complete the work within the stipulated period. For effective management of the project, feeder-wise implementation of solarisation work is to be carried out. The work progress of the contractor will be reviewed on fortnight basis by Discom.
- d) In addition to above, the contractor shall provide CMC for a period of 5 years **from the date of commissioning of the last system of total awarded work or, 9 months from the date of award of work (LoA), whichever is later**, including insurance coverage for the installed systems against natural calamities and theft.

1.1.7. Project milestones and timeline

S. No.	Milestone	Timeline (T is date of award of work)
1	Team mobilization, site survey and submission of feeder-wise consumer list with their consent for solarization of water pumps	T + 1 month
2	Completion of design, supply, installation, commissioning and testing of grid interactive solar PV systems at all identified locations	T + 9 months
5	Completed Comprehensive annual maintenance of all installed systems for 5 years	T + 69 months

SECTION - D: ELIGIBILITY & QUALIFICATION

D.1. Eligibility Requirement

1.1.1. The detail of eligibility requirements is provided in the table below. The bidders are required to furnish the required supporting documents along with the Technical Bid.

S. No.	Criteria	Documents Required
1.1.	Bidder can be sole/ single bidder OR, Joint Venture (JV) of up to 2 (two) members, with one of the members as a Lead Member	In case of JV, Deed of Undertaking
1.2.	The Bidder should have any of the following legal status: a) Body incorporated in India under the Companies Act, 2013 including any amendment thereto; OR b) Body incorporated in India under the Limited Liability Partnership (LLP) Act, 2008 including any amendment thereto; OR c) Firm registered under Partnership Act, 1932 in India; OR d) Sole Proprietor In case of JV, all the members must fulfill this requirement and submit the documents as per the Tender Document.	a) In case of Company – Copy of Registration/ Incorporation Certificate b) In case of LLP – Copy of Deed of Partnership c) In case of Partnership – Copy of Deed of Partnership d) In case of Sole Proprietor – Duly notarized Undertaking from Sole proprietor
1.3.	The Bidder must have the required GST Registration In case of JV, all the members must fulfill this requirement.	Copy of GST registration certificate with legible GSTIN.
1.4.	The Bidder must have valid PAN Number In case of JV, all the members must fulfill this requirement.	Copy of Pan Card
1.5.	The Bidder should have Electrical contractor license of class "A"/"B" for Electrical works in Rajasthan. In case of non-availability of the same at the time of bid submission, the contractor should submit a valid electrical contractor license of Class "A"/"B" issued by Govt. of Rajasthan within 1 month of award of contract. The bidder should submit an undertaking in this regard along with the bid. In case of JV, any one of the members must fulfill this requirement and submit the documents as per the Tender Document.	Copy of Registration Certificate issued by Government of Rajasthan
1.6.	The Bidder shall be a manufacturer of solar panels or, solar water pump. In case of JV, any member must fulfill this requirement and the other partner should be engaged in the business of electrical works. The JV must submit the documents as per the Tender	Statutory Documents substantiating this requirement along with Documents submitted in Clause 1.2 of this Section above.

S. No.	Criteria	Documents Required
	document.	
1.7.	The bidder should be having unblemished record and must not be blacklisted or declared ineligible for corrupt & fraudulent practices by “any state/ central government” department/ company / entity” as on date of bid opening. In case of JV, all the members must fulfill this requirement.	The bidder shall provide an Undertaking as per the format provided in SECTION - J: Format J.22. In case of JV, all the members must submit the undertaking as per the format provided in SECTION - J: Format J.22.
1.8.	The bidder must submit a Power of Attorney (POA) authorizing a person to sign the documents on behalf of the Bidder, submit technical, commercial information and attend meetings on behalf of the Bidder.	Sole Bidder to provide POA as per the applicable Law as provided in SECTION - J: Format J.3-A In case of JV, Undertaking by JV as per the format provided in SECTION - J: Format J.5 and POA as per the format provided in SECTION - J: Format J.4
1.9.	The bidder should have “No Conflict of Interest” as defined in SECTION - F: clause F.11 of this tender document. Bidders have an obligation to disclose any situation of actual or potential conflict of interest. Failure to disclose said situations may lead to the disqualification of the Bidder or the termination of its Contract. In case of JV, all the members must fulfill this requirement.	The bidder shall provide an undertaking as per the format provided in as per the format provided in SECTION - J: Format J.14 In case of JV, all the members shall submit the undertaking as per the format provided in SECTION - J: Format J.14

1.1.2. Qualification Requirement

The details of qualification requirements is provided in the table below. The bidders are required to furnish the required supporting documents along with the Technical Bid.

S. No.	Criteria	Documents Required
1.1.	Technical Criteria	
1.1.1.	Bidder shall have experience of execution of supply, installation and maintenance of grid connected / off-grid Solar Photovoltaic Systems (SPV) (SPV Pumps / Rooftop SPV / Ground mounted SPV / Mini-grid / SPV home lighting) during last Five years [i.e. 2014-15 to 2018-19] OR, during 2015-	1. The details of projects executed during the mentioned period should be listed in as per the format provided in SECTION - J: Format J.10 & J.11 Notarized Copy of work orders and a certificate issued by the SNA/ Govt. Organization/SECI/PSUs

S. No.	Criteria	Documents Required
	<p>16 to 31st Dec 2019. The works shall have been executed under SNA/ Govt. Organization/SECI/PSUs only with total cumulative order value of not less than 50% of the estimated cost of the lot(s).</p> <p>In case of JV, both the partners should collectively meet the total work experience requirement i.e. total cumulative order value of works executed should not be less than 50% of the estimated cost of the lot(s).</p> <p>In case a bidder is quoting for more than one Lot, qualification requirement shall be sum of Lot wise requirements of all quoted Lots.</p>	<p>towards the satisfactory work completion to be furnished by the bidder. The certificate shall not be issued by the officer below the equivalent rank of Executive Engineer of Concerned Entity. In absence of any one, it will not be considered for qualifying in technical bid.</p> <p>2. Work experience Certificate having value of completed work in the name of Bidder duly certified by Practicing Chartered Accountant as per the format provided in SECTION - J: Format J.10-Amentioning UDIN</p>
1.2.	Financial Criteria	
1.2.1.	<p>The Bidder should have positive net worth for each of the last three Financial Years (FY16-17, FY17-18, and FY18-19).</p> <p>In case of JV, all the partners of JV shall meet individually this qualification.</p>	<p>1. Certificate fulfilling required financial criteria in the name of Bidder duly certified by Practicing Chartered Accountant as per the format provided in SECTION - J: Format J.12, duly mentioning UDIN</p>
1.2.2.	<p>Minimum Average Annual Turnover (MAAT) during any 3 best out of last five financial years (FY14-15, FY15-16, FY16-17, FY17-18, and FY18-19) of the bidder shall not be less than 50% of estimated cost of the lot.</p> <p>In case a bidder is quoting for more than one Lot, qualification requirement shall be sum of Lot wise requirements of all quoted Lots.</p> <p>In case of JV, all the partners of the JV shall meet, collectively the qualification requirement. The figures for each of the partner of the joint venture shall be added together to determine the bidder's compliance with this qualifying criteria; however in order for a joint venture to qualify, the partner(s) of joint venture must meet the following minimum criteria:</p>	<p>2. Firm's Annual Audit Report, Balance sheet, Profit & Loss and Income Tax Returns / CA certificate for last Five years i.e. F.Y: 2014-15, 2015-16, 2016-17, 2017-18 & 2018-19.</p>

S. No.	Criteria	Documents Required
	<p>“The Lead partner shall meet not less than 40% AND the other partner shall meet not less than 30% of MAAT requirement. Collectively, JV shall meet the 100% requirement as in this MAAT qualification i.e. bidder’s MAAT should not be less than 50% of estimated cost of the lot.”</p>	
1.2.3.	Certificate from Banker	<p>A certificate from banker (as per the format provided in SECTION - J: Format J.13) indicating various fund based/non fund based limits sanctioned to the bidder and the extent of utilization as on date Such certificate shall have been issued not earlier than three months prior to the date of bid opening. Wherever necessary, JVVNL may make queries with the Bidders’ bankers.</p> <p>In case of Bid Submitted in JV, the certificate from Bank for all the JV partners be furnished.</p>

1.1.3. Key Information regarding Documentary proofs

- a) The bidder must fill up above information clearly in enclosed sheet and attach all required documents in support as at a glance in Technical bid.
- b) If supporting documents are not attached for each eligible criterion above, the bid may be rejected without further reference.
- c) **It will be mandatory to use indigenously manufactured solar panels with indigenous solar cells and modules. To ensure the same, submission of authorization or DCR certificates from Indian cell supplier(s) will be mandatory. Domestic manufacturing of solar cells and panels will also be ensured through inspection and verification at module manufacturing unit of the respective OEM. Further, inverters/controllers and the balance of system should also be manufactured indigenously. If required, MNRE may conduct its independent inspection or verification to ensure domestic manufacturing requirement. The contractor has to declare the list of imported components used in the solarisation system.**

D.2. Joint Venture Participation

2.1.1. Unless otherwise mentioned in Key Bid Data in SECTION - B:, bids submitted by a joint venture having not more than two partners with one partner as lead partner, if allowed as per stipulated Qualification Requirements, shall comply with the following requirements:

- i. The bid shall include all the information required as described above for each joint venture partner.

- ii. The bid shall be signed so as to be legally binding on both the partners.
- iii. One of the partners responsible for performing a key component of the contract shall be designated as leader; this authorization shall be evidenced by submitting with the bid a power of attorney signed by legally authorized signatories as per Format J.4.
- iv. The leader shall be authorized to incur liabilities and receive instructions for and on behalf of any and both the partners of the joint venture, and the entire execution of the contract, including payment, shall be done exclusively with the leader.
- v. All partners of the joint venture shall be liable jointly and severally for the execution of the contract in accordance with the contract terms.
- vi. A copy of the agreement entered into by the joint venture partners shall be submitted with the bid as per Format J.5, including interalia delineation of responsibilities and obligations of each partners appended thereto, not withstanding the joint and several liability.
- vii. The joint venture agreement should indicate precisely the responsibility of all members of JV in respect of planning, design, survey, manufacturing, supply, installation and commissioning.
- viii. All members of JV should have active participation in execution of the contract. This should not be varied/modified subsequently without prior approval of the Employer.
- ix. In order for a joint venture to qualify, both the partners must meet the minimum criteria listed in the Qualification Requirement for the Bidder for an individual Bidder for the component of the contract they are designated to perform. Failure to comply with this requirement will result in rejection of the joint venture bid.
- x. A firm can be a partner in only one joint venture; bids submitted by joint ventures including the same firm as partner will be rejected.

SECTION - E: SUBMISSION OF BIDS

E.1. Sale of Tender Document

The sale/ download of Tender Document shall commence as per the date specified in SECTION - B: Point (v). The complete Tender Document is also placed on the Bidding Portal specified in SECTION - B: Point (xiii). The prospective Bidders are permitted to download the Tender Document from any of the specified websites/ Bidding Portal but must pay the cost of Tender Document, E-procurement processing fees & Bid Security while submitting the Bid to the Discom in the manner prescribed in the Tender Document.

E.2. Local Conditions

It will be imperative on each Bidder to fully acquaint himself of all local conditions and factors which may have any effect / bearing on the execution of the works covered under this Tender Document. JVVNL, as applicable, shall not entertain any request for clarifications from the Bidder, regarding such local conditions, post award of contract. It must be understood and agreed that such factors have properly been investigated and considered while submitting the Bid. No claim for financial adjustment to the contract awarded under this Tender Document will be entertained by the JVVNL as applicable. Neither any change in the time schedule of the contract nor any financial adjustments arising thereof shall be permitted by the JVVNL as applicable, which are based on the lack of such clear information or its effect on the cost of the works to the Contractor. The Contractor can take few visits of locations of different area to get acquainted with local conditions, if required.

E.3. Clarification and Amendment of Bidding Document

3.1.1. Clarifications to the Tender Document

- a) A prospective bidder requiring any clarification on the Tender documents may notify JVVNL through email as specified in the SECTION - L: Format L.1 and shall reach before the specified Date and Time of Pre-Bid meeting as per the information provided in SECTION - B:.
- b) JVVNL will only accept Bidder queries sent through email, as per the specified Format, on or before the date and time specified in SECTION - B: of Tender Document.
- c) JVVNL would prepare and upload the corrigendum and final Tender Document based on modifications (if any).

E.4. Amendment of Bidding Document

- 4.1.1. At any time prior to the deadline for submission of the Bids, JVVNL may amend the Tender document by issuing Corrigendum/ Addenda.
- 4.1.2. Any Corrigendum/ Addendum issued shall be a part of the Tender document and shall be communicated on the Bidding Portal.
- 4.1.3. To give prospective Bidders reasonable time in which to take a Corrigendum/Addendum into account in preparing their Bids, JVVNL may, at its discretion, extend the deadline for the submission of the Bids.
- 4.1.4. Any change in date of submission and opening of bids would be published on Bidding Portal.

E.5. Submission of Bid Security

- 5.1.1. Bidder shall have to deposit Bid Security of amount as detailed in SECTION - B: Point (iv) in the form of Demand Draft / Bankers cheque / Bank Guarantee (BG) of scheduled bank (valid for 30 days beyond the Bid Validity i.e. 6 months + (plus) additional 30 days grace period), without which Bid will not be considered and shall be summarily rejected.
- 5.1.2. The Bank Guarantee for bid security shall be executed on Rajasthan Non-Judicial Stamp (NJS) Paper worth 0.25% of BG value (Maximum Stamp Duty of Rs. 25,000). If the BG is furnished from bank of other state with different Stamp Worth, then the difference value will be submitted on Rajasthan NJS Paper.
- 5.1.3. Government undertakings PSUs are exempted for Bid Security deposition on producing certificate issued by competent authority in Hard Copy in envelope-1 and also online in cover-I.
- 5.1.4. The Bid Security will be refunded to all the Bidders within 30 days after execution/signing of the contracts with successful bidder and performance security deposit is obtained from successful bidder.
- 5.1.5. Forfeiture of Bid Security: The Bid Security taken from the Bidder shall be forfeited in the following cases:-
 - a) If the Bidder modifies/ withdraws its Bid except as per the provisions specified in this Tender Document;
 - b) If the Bidder withdraws its Bid before the expiry of the Bid validity period;
 - c) If the successful bidder fails to provide the Performance Security to Discom and execute the Contract within the stipulated time or any extension thereof provided by Discom;
 - d) If any information or document furnished by the Bidder turns out to be misleading or untrue in any material respect.
 - e) If the successful Bidder does not accept the Letter of Intent unconditionally within Three (3) days of issue of Letter of Intent or the period as extended by JVVNL.
 - f) If the Bidder breaches any provision of code of integrity prescribed for the Bidders specified by JVVNL.
 - g) In the event of a bidder not responding to further negotiations as required for selection of Contractor, JVVNL reserves the right to forfeit the Bid Security Deposit amount furnished by such Bidders.
- 5.1.6. Bid Security of a bidder lying with the JVVNL in respect of other bids awaiting decision will not be adjusted towards bid security for the fresh bids. The bid security money originally deposited may, however, would be taken into consideration in case bids are re-invited.
- 5.1.7. No interest shall be paid by JVVNL on the Bid Security.

E.6. Submission of Bids

- 6.1.1. A Two Part-Three Cover system shall be followed for the bid. The Bid shall be submitted on Bidding Portal in electronic format in the following manner. E-procurement system shall be followed for the Bid as per the RTPP Act 2012 and RTPP Rules 2013

6.1.2. The Bidder would ensure that all the required documents, as mentioned in this Tender Document, are submitted along with the Bid and in the prescribed format and manner only. Non-submission of the required documents or submission of the documents in different format/contents & different manner may lead to the rejections of the Bid submitted by the Bidder.

E.7. Language of Bids

7.1.1. Bidders are required to furnish all information and documents as called for in this tender document in English Language. Any printed literature furnished by the bidder may be in another language, provided that this literature is accompanied by an English translation, in such case, for the purpose of interpretation of the document, the English version will govern.

E.8. Submission of Technical Bid

8.1.1. The technical bid comprises of Online (Cover-1 & Cover-2) duly digitally signed by Authorized Signatory and Physical Hard Copy duly signed by Authorized Signatory (Envelope-1 for hard copy of Cover-1 documents (Bid Security, Cost of Tender Document and E-procurement processing Fees & Envelope 2 Single Hard Copy of Cover 2 – Technical Bid)

8.1.2. Cover – 1 & Envelope - 1: The Cover-1 & Envelope - 1 Consists of

S. No.	Document Type	Cover – 1 Online	Envelope-1 Physical Hard Copy
1	Cost of Tender Document	Scanned copy of the receipt by JVVNL of submission of Cost of Tender Document	Original DD/Pay Order
2	E-Procurement Processing Fees	Scanned copy of the receipt by JVVNL of submission of E-procurement processing Fees.	Original DD/Pay Order
3	Bid Security	Scanned copy of the receipt by JVVNL of submission of banker's cheque / demand draft/Bank Guarantee/ valid exemption certificate along with Affidavit	Original banker's cheque / demand draft/ Bank Guarantee/ valid exemption certificate and Affidavit

8.1.3. Cover – 2: Online Cover - 2 consists of following documents (To be uploaded in the format prescribed on the Bidding Portal).

S. No.	Document Type	Cover – 1 Online
1	Eligibility Criteria Documents	As per SECTION - J: Format J.9 and supporting documents as per Section F (1).
2	Qualification Criteria Documents	As per SECTION - J: Format J.10 supporting documents as per Section F (2).
3	Work Experience Certificate & Documents	As per SECTION - J: Format J.11 supporting documents as per Section F (2).
4	Financial Qualification Certificate & Documents	As per SECTION - J: Format J.12 supporting documents as per Section F (2).
5	Bidder's Banker Certificate	As per SECTION - J: Format J.13 supporting documents as per Section F (2).
6	No-blacklisting Undertaking	As per SECTION - J: Format J.22

S. No.	Document Type	Cover – 1 Online
7	No-Conflict of Interest Undertaking	As per SECTION - J: Format J.14
8	Power of Attorney	Power of Attorney in favour of Authorized Signatory by Sole Bidder SECTION - J: Format J.3 and in case of JV, POA as per Format in As per SECTION - J: Format 0 for Authorized Signatory and Undertaking by JV for Bid submission as per As per SECTION - J: Format J.5
9	Declaration as per RTPP Act 2012 & RTPP Rules 2013	As per SECTION - J: Format J.14,J.15,J.16,J.17
Other Bid Documents		
10	Bid Submission Letter/ Undertaking	As per SECTION - J: Format J.6
11	Summary Details of Bidder	As per SECTION - J: Format J.7
12	Declaration of Material Offered	As per SECTION - J: Format J.8
13	Integrity Pact	SECTION - J: Format J.20
14	Declaration by the Bidder regarding Omissions/ Inconsistencies/ Reservations	SECTION - J: Format J.19
15	Declaration by the Bidder regarding Deviations	SECTION - J: Format J.18
16	Bank Guarantee Verification Checklist	SECTION - J:Format J.21
17	Signed/ Initialled & Seal	The Complete Tender Document shall have to be signed/ Initialled sealed as token of acceptance of all terms & conditions of Tender Document while submitted bid.

8.1.4. The technical bid (all the information required in the tender document pursuant to the desired formats except Price Bid) is to be submitted online in Cover – 2 before the prescribed time on the Bidding Portal. Also, one hard copy of technical bid is to be submitted at the Office of Superintending Engineer (Regulation), JVVNL. Further, all the documents which are executed on Stamp Papers are to be submitted with due care. All such submissions shall have to be made by Bidders before the scheduled time and place as per the details mentioned in SECTION - B: Point (vi).

8.1.5. In case of any discrepancy between the hard copy submitted and online submission of technical bid on Bidding Portal, the details as provided in the online technical bid shall supersede the hard copy submission.

E.9. Submission of Price Bid:

9.1.1. Bidders shall quote their lowest rates / costs for the work of design, survey, supply, installation, commissioning, testing and five years free comprehensive maintenance of SPV as per terms & condition of this tender including all applicable taxes, duties etc. pursuant to SECTION - J: Format J.23 in MS Excel file on Bidding Portal.

- 9.1.2. The rates quoted by Bidders for the work of design, survey, supply, installation, commissioning, testing and 5 (five) years free comprehensive maintenance of SPV systems must be firm and fixed, FOR site(s) as per prescribed format.
- 9.1.3. Financial/ Price Bid consist the details of prices as per Price Schedule in MS Excel File (.xls file of price Bid) published with NIT and this tender document on Bidding Portal.
- 9.1.4. Price bid in form of price schedule shall be uploaded by the bidder on Bidding Portal before scheduled due date and time for submission of bids as mentioned in SECTION - B: Point (vi). The locked price bid shall be opened on notified date and time. Due intimation shall be given to technically and commercially cleared bidders about date and time of opening of prices bids on bidding portal.
- 9.1.5. In case a bidder is submitting bid for more than one lot, then separate price bids are to be uploaded / submitted for each lot on the bidding portal.
- 9.1.6. Important Note: Bidders are directed that price offer shall be furnished online only in cover-3 pursuant to the format provided separately in MS Excel file on Bidding Portal. If price offer submitted in technical bid (i.e. in cover-1 and cover-2), such bids will be rejected in technical bid evaluation stage and will not be considered for further process to conclude the bid.
- 9.1.7. Unless otherwise indicated in the Tender document, prices quoted by Bidder shall correspond to 100% cost & risk of the scope of work to be delivered.
- 9.1.8. The Joint venture Bids shall be acceptable as per following conditions :
- a) The JV member has procured the tender document in its own name.
 - b) The lead member shall submit Joint Venture Undertaking along with the Bid.
 - c) All requirements as per SECTION - D: of the tender document can be furnished by both Joint Venture members jointly or individually as required in relevant clauses of SECTION - D:.
 - d) The lead member shall undertake the responsibility for all obligations and liabilities relating to the project in accordance with the terms of this tender.
 - e) The work would be awarded to the lead member and Discom would acknowledge other Joint Venture member in the work award letter and other communications.
 - f) All payments from Discom will be made in informed joint bank account of Joint Venture firms only, the details of such bank account shall be provided by the Bidder.
 - g) Only one agreement with only one party will be accepted under Joint Venture agreement.
 - h) A firm/entity can be a partner in only one Joint Venture; bids submitted by joint ventures including the same firm/ entity as partner shall be rejected.

E.10. Cost of Bidding:

- 10.1.1. The Bidder shall bear all costs associated with the preparation and submission of its Bid, and JVVNL shall not be responsible or liable for those costs, regardless of the conduct or outcome of the bidding process.

E.11. Alternative Bids:

11.1.1. Alternative bids shall not be considered at all.

E.12. Period of Validity of Bids:

- 12.1.1. Bids shall remain valid for 6 months from the date of opening of Technical Bid as prescribed by JVVNL. A Bid valid for a shorter period shall be rejected and treated as non-responsive.
- 12.1.2. In exceptional circumstances, JVVNL may solicit the Bidder's consent to an extension of the period of validity. The request and the responses thereto shall be made in writing.

E.13. Format and Signing of Bid

- 13.1.1. The bid forms/templates/annexure etc., wherever applicable, shall be typed or written in indelible ink and shall be signed (all the pages) by a person duly authorized by Bidder to sign, in token of acceptance of all the terms and conditions of the Tender Document. This authorization shall consist of a written confirmation in the form of Power of Attorney as specified in the bidding document and shall be attached to the bid.
- 13.1.2. Any amendments such as interlineations, erasures, or overwriting shall be valid only if they are signed or initialed by the authorized person signing the bid.
- 13.1.3. The bid documents shall be properly checked before uploading for submission of Bids.
- 13.1.4. The bid, duly signed (digitally) by Auth. Signatory, shall be uploaded on the Bidding portal in respective file/ format.
- 13.1.5. Bidders must submit their bids online at Bidding Portal. Bids received by another other means except as desired in this Tender Document shall not be accepted.
- 13.1.6. If bids are not submitted as per the details mentioned in this Tender document and Bidding Portal, the tendering authority shall reject the bid.
- 13.1.7. Bidders are required to carefully go through the instructions included in the Tender Document and furnish complete information, necessary documents and schedules.
- 13.1.8. The Bidder shall sign the bid on each page and also at the specified location. Each and every paper enclosed must be given a page no. like 1,2,3,.....etc. & a bid summary must be enclosed along with covering letter on the Letter Head of the firm in the following format:

S.No.	Particulars/brief of information/ schedule/ Annexure	Page No:
1.		
2.		
3		
.....		
	Total Page	

Signature of Authorized Signatory, Seal of Entity, Date and Place

E.14. Deadline for Submission of Bids

- 14.1.1. Bids must be submitted on the Bidding Portal no later than the date and time indicated in SECTION - B: Point (vi).
- 14.1.2. Normally, the date of submission and opening of bids would not be extended. However, in exceptional circumstances or when the Tender Document is required to be substantially modified as a result of discussions in pre-bid meeting and the time with the prospective bidders for preparation of bids appears insufficient, the date may be extended by the Discoms, which shall be informed on the Bidding Portal. In such cases, it would be ensured that after issue of corrigendum, reasonable time is available to the Bidders to prepare and submit their bids. Any change in date of submission and opening of bids would also be placed on the Bidding Portal. However, if the modifications in Tender document, specifications of goods and service are substantial, fresh publication of original Tender Document may also be issued.
- 14.1.3. JVVNL may, at its discretion, extend the deadline for the submission of bids by amending the Tender document, in which case all rights and obligations of the JVVNL and bidders previously subject to the deadline shall thereafter be subject to the deadline as extended.

E.15. Withdrawal, Substitution, and Modification of Bids

- 15.1.1. A Bidder may withdraw its bid or re-submit its bid (technical and/ or financial cover) as per the instructions/ procedure mentioned at Bidding Portal under the section “Bidder’s Manual Kit”, but not after bid submission end date and time.
- 15.1.2. Bids withdrawn shall not be opened and processed further.

SECTION - F: BID OPENING & EVALUATION

F.1. Bid Opening

- 1.1.1. JVVNL will first perform the technical bid opening, which is a critical event in the bidding process. This shall be done online on the stipulated time.
- 1.1.2. After opening of Bids and till final selection of successful Bidder(s), no correspondence of any type will be entertained, unless called for by JVVNL. Any type of uncalled for clarifications on prices and or rebates shall not be accepted.

F.2. Confidentiality

- 2.1.1. Information relating to the examination, evaluation, comparison, and post qualification of bids, and recommendation of contract award, shall not be disclosed to bidders or any other persons not officially concerned with such process until publication of the Contract award.
- 2.1.2. Any attempt by a bidder to influence JVVNL or other officials in the examination, evaluation, comparison, and post qualification of the bids or Contract award decisions may result in the rejection of his bid.

F.3. Code of Integrity

- 3.1.1. All the officers or employees of the Discom shall:
 - a) maintain an unimpeachable standard of integrity both inside and outside their office
 - b) act in accordance with the provisions of the Act, these rules, guidelines issued under the Act and instructions
 - c) not allow any bidders to have access to information on a particular procurement, before such information is available to the public at large
 - d) not intentionally use unnecessarily restrictive or “tailored” specifications, terms of reference or statements of work that can discourage competition
 - e) not solicit or accept any bribe, reward or gift or any material benefit of any directly or indirectly promise of future employment from anyone, who has sought or is seeking procurement from Discom
 - f) not have a financial interest in any bidder(s) responding to JVVNL’s bidding process and any person having financial interest in any bidder shall not participate in this tender process
 - g) not disclose proprietary and source selection information, directly or indirectly, to any person other than a person authorised to receive such information
 - h) treat all bidders in a fair and equitable manner in line with the principle of fairness, integrity and transparency in the procurement process
 - i) provide all bidders identical information at the same time, during the bidding process;
 - j) apply the same criteria of evaluation as specified in the bidding documents, bidder registration documents or pre-qualification documents and under no circumstances new evaluation criteria shall be introduced during the evaluation process

- k) not entertain any favour, recreation, presents, services, etc. from the bidders or prospective bidders
- l) protect the interests of the Discom under all circumstances while dealing with information and information sources
- m) maintain confidentiality of all bids
- n) ensure that the selection of bidder is as per the Tender Document and is not influenced by personal reasons attributable to concerned officials in any manner
- o) Disclose conflict of interest, if any.

3.1.2. Any Bidder participating in Tender process shall:

- a) not offer any bribe, reward or gift or any material benefit either directly or indirectly in exchange for an unfair advantage in procurement process or to otherwise influence the procurement process
- b) not misrepresent or omit information that misleads or attempts to mislead so as to obtain a financial or other benefit or avoid an obligation
- c) not indulge in any collusion, bid rigging or anticompetitive behaviour to impair the transparency, fairness and progress of the Tender process
- d) not misuse any information shared between Discom and the bidders with an intent to gain unfair advantage in the Tender process
- e) not indulge in any coercion including impairing or harming or threatening to do the same, directly or indirectly, to any party or to its property to influence the Tender process;
- f) not obstruct any investigation or audit of a Tender process
- g) disclose conflict of interest, if any; and
- h) disclose any previous transgressions with any entity in India or any other country during the last three years or any debarment by any other procuring entity.

F.4. Breach of code of integrity by the bidder

- 4.1.1. Without prejudice to the provisions of Chapter IV of the RTPP Act 2013, in case of breach of any provision of the code of integrity by a bidder or prospective bidder, as the case may be, JVVNL may take appropriate action in accordance with the provisions of subsection (3) of section 11 and section 46 of the RTPP Act 2013.

F.5. Vexatious Appeals & Complaints

- 5.1.1. Whoever intentionally files any vexatious, frivolous or malicious appeal or complaint under the “The Rajasthan Transparency Public Procurement Act 2012 / Rules 2013”, with the intention of delaying or defeating any procurement or causing Loss to the Discom or any other bidder, shall be punished with fine which may extend to Twenty Lakh Rupees or five per cent of the value of procurement, whichever is less.

F.6. Offences by Firms/ Companies

- 6.1.1. Where an offence under “The Rajasthan Transparency Public Procurement Act 2012 / Rules 2013” has been committed by an entity, every person who at the time the offence was committed was in charge of and was responsible to the entity for the conduct of the business of the entity, as well as the entity, shall be deemed to be guilty

of having committed the offence and shall be Liable to be proceeded against and punished accordingly:

Provided that nothing contained in this sub-section shall render any such person Liable for any punishment if he proves that the offence was committed without his knowledge or that he had exercised all due diligence to prevent the commission of such offence.

- 6.1.2. Notwithstanding anything contained in (a) above, where an offence under this Act has been committed by an entity and it is proved that the offence has been committed with the consent or connivance of or is attributable to any neglect on the part of any director, manager, secretary or other officer of the entity, such director, manager, secretary or other officer shall also be deemed to be guilty of having committed such offence and shall be Liable to be proceeded against and punished accordingly.
- 6.1.3. For the purpose of this clause-
- a) "Entity" means a body corporate and includes a Limited Liability partnership, firm, registered society or co- operative society, trust or other association of individuals; and
 - b) "Director" in relation to a Limited Liability partnership or firm, means a partner in the firm.
- 6.1.4. Abetment of certain offences: Whoever abets an offence punishable under this Act, whether or not that offence is committed in consequence of that abetment, shall be punished with the punishment provided for the offence.

F.7. Debarment from Bidding

- 7.1.1. A bidder shall be debarred by the Discoms if he has been convicted of an offence
- a) under the Prevention of Corruption Act, 1988 (Central Act No. 49 of 1988); or
 - b) Under the Indian Penal Code, 1860 (Central Act No. 45 of 1860) or any other Law for the time being in force, for causing any Loss of Life or property or causing a threat to public health as part of execution of a public procurement contract.
- 7.1.2. A bidder debarred under sub-clause 7.1.1 (a) above shall not be eligible to participate in a bidding process of any of the three Rajasthan Discoms for a period not exceeding three years commencing from the date on which he was debarred.
- 7.1.3. If the Discoms find that a bidder has breached the code of integrity prescribed in terms of "Code of Integrity for bidders" above, it may debar the bidder for a period not exceeding three years.
- 7.1.4. Where the entire Bid Security or the entire Performance Security or any substitute thereof, as the case may be, of a bidder has been forfeited by the Purchaser in respect of any bidding process or contract, the bidder may be debarred from participating in any bidding process undertaken by the Discoms for a period not exceeding three years.
- 7.1.5. The Discoms shall not debar a bidder under this section unless such bidder has been given a reasonable opportunity of being heard

F.8. Clarification of Bids

- 8.1.1. To assist in the examination, evaluation, comparison and qualification of the bids, the JVVNL may, at its discretion, ask any bidder for a clarification regarding its bid. The JVVNL's request for clarification and the response of the bidder shall be in writing.
- 8.1.2. Any clarification submitted by a bidder with regard to its bid that is not in response to a request by JVVNL shall not be considered.
- 8.1.3. No change in the prices or substance of the bid shall be sought, offered, or permitted, except to confirm the correction of arithmetic errors discovered by the committee in the evaluation of the financial bids.
- 8.1.4. No substantive change to qualification information or to a submission, including changes aimed at making an unqualified bidder, qualified or an unresponsive submission, responsive shall be sought, offered or permitted.
- 8.1.5. All communications generated under this rule shall be included in the record of the procurement proceedings.

F.9. Technical Bid Opening:

- 9.1.1. First of all Envelope-1 in hard copy (in physical form) furnished by bidder shall be opened as per the prescribed mentioned in the SECTION - B: and documents submitted against Tender Cost, RISL charges & Bid Security shall be examined as per the requirement of tender conditions. If found as per requirements, the Cover-1(online) containing scanned copies of documents submitted for Tender Cost, RISL e-proc charges and Bid Security shall be opened and examined pursuant to the tender conditions as per the date & time specified in SECTION - B:. All the documents as furnished in envelope-1 shall be available in cover-1.
- 9.1.2. Cover-2 (i.e. Technical Bid) shall be opened for only those bidders shall be opened, whose documents as provided in Clause 9.1.1 above in this Section are found responsive as per the tender conditions. If the documents mentioned, are found non-responsive pursuant to the tender conditions, the Cover-2 of such bidders shall not be opened and such bidders shall be disqualified.

F.10. Technical Bid Evaluation:

10.1.1. Guiding Principle for Evaluation of Bids

- a) JVVNL shall strictly apply only and all of the evaluation and qualification criteria specified in this Tender Document.
- b) The determination shall be based upon an examination of the documentary evidence of the bidder's qualifications and proposed solution submitted by the Bidder.
- c) Lot wise evaluation of technical bid shall be done by JVVNL.

10.1.2. Determination of eligibility and responsiveness

- a) A Bidder shall be considered to be eligible if it meets the eligibility criteria mentioned in the Tender Document.

10.1.3. A responsive Bid is one that meets the requirements of the Tender document without any material deviation, reservation, or omission where:

- a) “deviation” is a departure from the requirements specified in the Tender document;
- b) “reservation” is the setting of limiting conditions or withholding from complete acceptance of the requirements specified in the Tender Document; and
- c) “Omission” is the failure to submit part or all of the information or documentation required in the Tender document.

10.1.4. A material deviation, reservation, or omission is one that,

- a) If accepted, shall affect in any substantial way the scope, quality, or performance of the subject matter of procurement specified in the Tender documents; or
- b) Limits in any substantial way, inconsistent with the Tender documents, JVVNL’s rights or the Bidder’s obligations under the proposed contract; or
- c) If rectified, shall unfairly affect the competitive position of other Bidders presenting responsive Bids.

10.1.5. Non-material Non-conformities in Bids

- a) JVVNL may waive any non conformities in the Bid that do not constitute a material deviation, reservation or omission, the Bid shall be deemed to be substantially responsive.
- b) JVVNL may request the Bidder to submit the necessary information or document Like audited statement of accounts/ CA Certificate, Registration Certificate, VAT/ CST clearance certificate, ISO/ CMMi Certificates, etc. within a reasonable period of time. Failure of the Bidder to comply with the request may result in the rejection of its Bid. During technical bid evaluation, JVVNL may, at its discretion, ask the Bidder for a clarification of its bid. The request for clarification and the response shall be in writing, and no change in the price or substance of the bid shall be sought, offered or permitted.
- c) JVVNL may rectify non-material nonconformities or omissions on the basis of the information or documentation received from the Bidder under clause 10.1.5 (b) of this Section. To this effect, the bid price shall be adjusted, for comparison purposes only, to reflect the price of the missing or nonconforming item or component. The adjustment shall be made using the method indicated in pre-qualification and Evaluation Criteria of this bidding document.

10.1.6. JVVNL shall examine the technical aspects of the Bid in particular, to confirm that all requirements of bidding document have been met without any material deviation, reservation or omission.

10.1.7. JVVNL shall regard a Bid as responsive if it conforms to all requirements set out in the Tender Document, or it contains minor deviations that do not materially alter or depart from the characteristics, terms, conditions and other requirements set out in the Tender Document, or if it contains errors or oversights that can be corrected without touching on the substance of the Bid.

10.1.8. JVVNL shall take up detailed evaluation of the responsive bids only.

F.11. Conflict of Interest

11.1.1. The Discoms considers a conflict of interest to be a situation in which a party has interests that could improperly influence that party’s performance of official duties or

responsibilities, contractual obligations, or compliance with applicable laws and regulations. In pursuance of Discoms' procurement ethics, the bidders, suppliers, and contractors under contracts, observe the highest standard of ethics, the Discoms will take appropriate actions against the Bidder, if it determines that a conflict of interest has flawed the integrity of any procurement process. Consequently, all Bidders found to have a conflict of interest shall be disqualified.

- 11.1.2. Conflict of interest will be determined in accordance with clause 81 of the Rajasthan Transparency in Public Procurement Rules (RTPP) 2013.
- 11.1.3. Further, it may be considered to be in a conflict of interest with one or more parties in the bidding process if
- a) they have controlling shareholders in common; or
 - b) it receives or have received any direct or indirect subsidy from any of them; or
 - c) they have the same legal representative for purposes of the Bid; or
 - d) they have a relationship with each other, directly or through common third parties, that puts them in a position to have access to information about or influence on the Bid of another Bidder, or influence the decisions of JVVNL regarding this bidding process.
- 11.1.4. Bids considered non-responsive are liable for disqualification/ rejection for the following reasons:
- a) Bid is not received by the due date & time and Bids is not accompanied with the required documents & schedules.
 - b) Bid not submitted in accordance with Tender Document.
 - c) Bid do not meet the minimum eligibility criteria as mentioned in the bidding document.
 - d) Bids is not accompanied by Bid Security /Cost of Tender Document / RISL E-procurement processing Fees.
 - e) Conditional Bid shall be rejected.
 - f) Proposal is not valid for at least six (6) months from the date of opening of online Technical Bid.
 - g) During validity of the Bid or its extended period, if any, Bidder increases his quoted prices.
 - h) Desired certificates in the required in the Tender Document not attached by the bidder.
 - i) Prices not quoted in prescribed Performa /schedule.
 - j) Bidder has made misleading or false representations in the forms, statements and attachments submitted in proof of the eligibility requirements.
 - k) Bidder is found to have a record of poor performance such as abandoning work, not properly completing the contract, inordinately delaying completion, being involved in major litigation or financial failures, etc.
 - l) Bidder failed to provide clarifications related thereto, when sought.

- m) Bidder has submitted more than one bid. This will cause disqualification of all Bids submitted by such Bidders including forfeiture of the Bid Security.
- n) Bidder who is found to canvass, influence or attempt to influence in any manner for the qualification or selection process, including without limitation, by offering bribes or other illegal gratification shall be disqualified from the process at any stage.
- o) Bid is not meeting any other pre-requisite as spelt out elsewhere in this document.

11.1.5. JVVNL shall refer the evaluation report to the Competent Authority of JVVNL, which reserves the right to reject any Bid which is nonresponsive and no request for alteration, modification, substitution or withdrawal shall be entertained by JVVNL in respect of such Bids.

11.1.6. The Cover -3 – Price Bid shall be kept unopened and shall be opened later on the date and time intimated to the bidders who qualify in the evaluation of technical bids.

11.1.7. The eligible Bidders whose bid is determined to be substantially responsive shall be considered to be qualified in the technical evaluation, unless disqualified pursuant to clause 11.1.4 above in this Section, and shall be informed in writing about the date, time and place of opening of their financial bids.

11.1.8. The Bidders which could not qualify in technical evaluation will be informed about this fact. Their financial bid will be remain unopened for such Bidders and Bid Security refunded after completion of the bid process as mentioned in tender document.

F.12. Financial Bid Opening:

12.1.1. Price bids (i.e. Cover-3) of only those bidders will be opened whose Bids are found responsive for respective lot and Bidders are technically eligible and qualified for the lot under evaluation.

F.13. Financial Evaluation:

13.1.1. To evaluate a bid, JVVNL shall consider the following: -

- a) The bid price as quoted in accordance with Tender document.
- b) Price adjustment for correction of arithmetic errors in accordance with Tender document.
- c) Lot wise evaluation of financial bids.

13.1.2. JVVNL's evaluation of a bid will exclude and not take into account any allowance for price adjustment during the period of performance of the Contract, if provided in the Bid.

13.1.3. The evaluation shall include all costs and all taxes and duties applicable to the bidder as per law of the Central/ State Government/ Local Authorities.

13.1.4. Correction of Arithmetic Errors

Provided that the bid is substantially responsive, the competent Procurement Committee shall correct arithmetical errors on the following basis:

- a) if there is a discrepancy between the unit price and the total price that is obtained by multiplying the unit price and quantity (months, number of consultants, etc.), the unit price shall prevail and the total price shall be corrected, unless in the

opinion of the tendering authority there is an obvious misplacement of the decimal point in the unit price, in which case the total price as quoted shall govern and the unit price shall be corrected;

- b) if there is an error in a total corresponding to the addition or subtraction of subtotals, the subtotals shall prevail and the total shall be corrected; and
- c) if there is a discrepancy between words and figures, the amount in words shall prevail, unless the amount expressed in words is related to an arithmetic error, in which case the amount in figures shall prevail subject to 13.1.4 (a) and (b) above.

13.1.5. Financial offers will be arranged in the ascending order for each lot, of their all-inclusive total quoted rates in the respective price bid i.e. L-1, L-2, L-3, L-4, L-5,Ln.

F.14. Negotiations

14.1.1. Except in case of procurement by method of single source procurement or procurement by competitive negotiations, to the extent possible, no negotiations shall be conducted after the pre-bid stage. All clarifications needed to be sought shall be sought in the pre-bid stage itself.

14.1.2. Negotiations may, however, be undertaken only with the lowest or most advantageous bidder under the following circumstances.

- a) when ring prices have been quoted by the bidders for the subject matter of procurement; or
- b) when the rates quoted vary considerably and considered much higher than the prevailing market rates.

14.1.3. The Competent Committee appointed by JVVNL shall have full powers to undertake negotiations. Detailed reasons and results of negotiations shall be recorded in the proceedings.

14.1.4. The lowest or most advantageous bidder shall be informed in writing either through messenger or by registered letter and email (if available). In case of urgency the Competent Committee, after recording reasons, may reduce the time, provided the lowest or most advantageous bidder has received the intimation and consented to regarding holding of negotiations.

14.1.5. Negotiations shall not make the original offer made by the bidder inoperative. The Competent Committee shall have option to consider the original offer in case the bidder decides to increase rates originally quoted or imposes any new terms or conditions.

14.1.6. In case of non-satisfactory achievement of rates from lowest or most advantageous bidder, the Competent Committee may choose to make a written counter offer to the lowest or most advantageous bidder and if this is not accepted by him, the committee may decide to reject and re-invite bids or to make the same counter-offer first to the second lowest or most advantageous bidder, then to the third lowest or most advantageous bidder and so on in the order of their initial standing and work / supply order be awarded to the bidder who accepts the counter-offer. This procedure can be used in exceptional cases only.

14.1.7. In case the rates even after the negotiations are considered very high, fresh bids shall be invited.

14.1.8. In the event of a bidder not responding to further negotiations as required for selection of suppliers, JVVNL reserves the right to forfeit the Bid Security Deposit amount furnished by such bidders.

F.15. Right to Reject by JVVNL

15.1.1. JVVNL reserves the right to accept or reject any bid, and to annul the bidding process and reject all bids at any time prior to award of contract, without thereby incurring any liability to the affected Bidder or bidders or any obligation to inform the affected Bidder or bidders of the grounds for JVVNL's action.

SECTION - G: AWARD OF CONTRACT

G.1. Award of contract

- 1.1.1. Based on the results of the financial evaluation, JVVNL shall identify the L1 Bidder i.e. bidder whose bid has been determined to be substantially responsive and to be the lowest evaluated bid for the lot, further provided that the Bidder is determined to be qualified, as per the Qualification Requirement specified in tender document for the lot to perform the contract satisfactorily.
- 1.1.2. Further, JVVNL shall award the Contract and issue LOI to L1 bidder for the lot. **A bidder can participate in maximum 2 lots and shall be awarded a maximum of 2 lots only. No splitting of lot quantity into multiple bidders. Each lot will be awarded to single bidder only.**
- 1.1.3. The following order shall be followed after selection of successful bidder(s) in the financial evaluation.
 - a) Issuance of Letter of Intent (LoI) by JVVNL and its unconditional acceptance by the Bidder(s) within 3 days from date of issuance of LoI.
 - b) Mutual agreement on PERT chart / Project Execution Plan duly signed and accepted by Contractor(s) and Discom within three days from date of acceptance of LoI.
 - c) Issue of Work Order by JVVNL and its unconditional acceptance by the Bidder within 3 (Three) days from date of issue of Work Order. The Successful Bidder shall also submit SECTION - K: Format K.6 along with acceptance of Work Order.
 - d) Submission of Performance Security, within 15 (fifteen) days from date of issue of LoA.

G.2. Performance Security

- 2.1.1. The successful bidder shall be required to furnish Performance Security @ 10% of the Contract Price (award value) within 15 (fifteen) days from date of issue of LoA, except the departments of the State Government and undertakings, corporations, autonomous bodies, registered societies, co-operative societies which are owned or controlled or managed by the State Government and undertakings of the Central Government. However, a declaration shall be taken such government owned departments which are exempted from submission of Performance Security. The Performance Security shall be returned after 63 (Sixty Three) months from the date of successful installation of the last system. The same shall be extended by the Contractor time to time till ninety (90) days beyond 63 (Sixty Three) months from the date of successful installation of the last system, as may be required under the Contract.
- 2.1.2. The Performance Security shall be in the Form of unconditional Bank Guarantee as per the SECTION - K: Format K.1
- 2.1.3. In case of award of the contract to a Joint Venture, the Bank Guarantees for performance security shall be submitted in the name of all the partner(s) of the Joint Venture "OR" in the name of Lead/other Partner in the Joint Venture submitting the bid.

- 2.1.4. The BG shall be from Any Government bank and in case of private bank as list provided in SECTION - B: (1.1.3).
- 2.1.5. The BG for performance security shall be executed on Rajasthan Non-Judicial Stamp Paper worth 0.25% of BG value or Rs. 25,000/- whichever is lower.
- 2.1.6. The BG shall be furnished in favour of Superintending Engineer (Regulation), JVVNL, Jaipur.

G.3. Forfeiture of Performance Security:

- 3.1.1. Apart from cases mentioned in the Tender Document regarding forfeiture of Performance Security, the Performance Security amount in full or part may also be forfeited in the following cases:
 - a) Failure in executing the Contract Agreement with the Discom
 - b) When the terms and conditions of contract is breached / infringed by the Successful Bidder/ Contractor
 - c) If the Successful Bidder/ Contractor fails to carry out the work satisfactorily
 - d) When contract is being terminated due to non-performance by the Successful Bidder/ Contractor
 - e) Notice of reasonable time will be given in case of forfeiture of Performance Security deposit. The decision of the JVVNL, as applicable, in this regard shall be final.
- 3.1.2. No interest will be paid by the Discoms on the amount of Performance Security.

G.4. Signing of Contract:

- 4.1.1. A procurement contract shall come into force from the date on which the Letter of Intent is dispatched to the successful bidder.
- 4.1.2. Contract Agreement (as per SECTION - K: Format K.14) shall be signed, (after unconditional acceptance of Work Order by Contractor) within 15 (fifteen) days from date of issue of Work Order and submission and acceptance of contract Performance Security.
- 4.1.3. If the bidder, whose bid has been accepted, fails to sign a written Contract or fails to furnish the required Performance Security within specified period, the JVVNL on instruction from the respective Discom shall take action against the successful bidder as per the provisions of the Act and these rules. The JVVNL may, in such case, cancel the tender process or if it deems fit, offer for acceptance the rates of lowest or most advantageous bidder to the next lowest or most advantageous bidder, in accordance with the criteria and procedures set out in the Tender Documents.
- 4.1.4. The bidder shall be asked to execute the agreement on a non-judicial stamp of Rajasthan State of value worth 0.25% of the contract value and submitted the same to the office of Superintending Engineer (Regulation), JVVNL, Jaipur

G.5. Reservation of Rights

- 5.1.1. To take care of unexpected circumstances, JVVNL / Discoms (as applicable) shall reserve the rights for the following:
 - a) Extend the closing date for submission of the bids.

- b) Amend the bidding requirements at any time prior to the closing date, with the amendment being notified to prospective bidders.
- c) Seek information from or negotiate with one or more of the bidders on any issue at any time and to continue to negotiate with one or more of the bidders.
- d) Discontinue negotiations at any time with any bidder.
- e) Allow a bidder to change its Technical proposal if the same opportunity is given to all bidders.
- f) To accept any bid not necessarily the lowest, reject any bid without assigning any reasons and accept bid for all or anyone or more of the articles for which bid has been invited or distribute items of stores to more than one bidder.
- g) Terminate or abandon the Tender procedure or the entire Project whether before or after the receipt of Bids.
- h) Seek the advice of external consultants to assist JVVNL in the evaluation or review of Bids.
- i) Make enquiries of any person, company or organization to ascertain information regarding the bidder and its Bid.
- j) Reproduce for the purposes of the procedure the whole or any portion of the Bid despite any copyright or other intellectual property right that may subsist in the Bid.

SECTION - H: GENERAL TERMS & CONDITIONS

H.1. Handing Over Asset:

- 1.1.1. After successful installation, commissioning, testing with User Acceptance Testing (UAT) of complete SPV system, the asset is to be jointly handed over to the beneficiary and concerned engineer in-charge of the Discom. The Handing over note covering the details of all the materials used and total work executed must be signed jointly by the beneficiary, Contractor & the Discom's Engineer In-charge. The copy of Installation Certificate along with beneficiary's certificate (SECTION - K: Format K.4 & K.7) to final bill is required to be submitted by Contractor for release of payment.
- 1.1.2. **User Acceptance Test (UAT) shall comprise of measurement and reporting of all technical parameters of system with jointly signed by contractor, engineer-in-charge and beneficiary. All BIS/MNRE technical standards shall be applicable for such UAT including inspection of support structures, modules, mounting, cabling, equipment labels, markings, placards, manufacturer identification, and specifications and ratings. Relevant IEC / BIS / MNRE standards shall be guiding standard for such tests or inspections.**
- 1.1.3. The Taking over Certificate (Format K.11) & Operational Acceptance Certificate (Format K.10) as well as completion certificate (K.9) shall be issued according on completion of requisite works and completion of Contract Period, if the complete scope of work is completed.

H.2. Payment Conditions

- 2.1.1. The contractor shall claim **feeder-wise** payment by submitting complete list of beneficiaries connected on the same feeder along with K. No., full addresses, date of installation, models and makes and serial numbers of systems & PV modules supplied along with the photographs of installed system duly verified by Engineer In-charge. **However, in case of special circumstances acceptable to DISCOM, if solarization of all consumers for the feeder cannot be done, DISCOM reserves the right to release payment for such feeder(s) to the contractor.**
- 2.1.2. Contractor shall submit their bills for SPV Systems installation completed to respective Engineer In-charge of Discom along with required documents/papers and obtain receipt of the same from Engineer In-charge of Discom. Nodal Officer will be informed about this along with receipt of Engineer In-charge & list of beneficiaries & details of installations within next 10 days.
- 2.1.3. The Final bill must be submitted to Engineer In-charge not later than 30 days after expiry of the scheduled time period & Nodal Officer shall be informed within the following 30 days along with receipt of Engineer In-charge along with list of beneficiaries & details of installations.
- 2.1.4. The payment of billed amount (Design, Survey, Supply, Installation, Testing and Commissioning and CMC) of SPV systems shall be released as per following terms:
 - (I) **Supply value of the total contract**
 - a) Mobilization advance equivalent to 10% of the supply value (inclusive of taxes) for total contract shall be released after receipt of claim from the Contractor with following documents to the Superintending Engineer (Regulation):

- i. Unconditional acceptance of the Letter of Award and signing of contract agreement by the Contractor.
 - ii. Contractor's detailed invoice.
 - iii. Submission and acceptance of unconditional & irrevocable part Bank Guarantees with value equivalent to the mobilization advance amount in favor of Superintending Engineer (Regulation), JVVNL as per proforma attached with SECTION - K: Format K.2. The said Bank Guarantees shall be initially valid upto end of ninety (90) days after the scheduled month of supply of materials and shall be extended from time to time till ninety (90) days beyond revised scheduled month of supply of materials, as may be required under the Contract. Also, the same shall be adjusted in the 1st instalment of supply value as mentioned below.
- b) 1st instalment of 40% of the supply value (inclusive of taxes) (including 10% mobilization advance) after delivery of material at site by the contractor for the feeders as per the instruction of nodal officer/ Engineer In-charge of Discom (to be claimed feeder-wise by the contractor) after receipt of claim (Supply) from the Contractor with following documents duly verified by Discom's concerned Nodal Officer/Engineer In-charge, will be made by Designated Payment Officer of Discom within 21 days from the date of submission of invoice along with relevant documents.
- i. Invoice issued by the Contractor
 - ii. Material Dispatch Clearance Certificate (MDCC) / Dispatch Instructions (DI) for dispatch of materials from the manufacturer's works. MDCC/DI shall be issued by Assistant Controller of Stores (ACOS) or, AEN of the concerned subdivision.
 - iii. Submission of certificate by Nodal Officer (Engineer-in-charge) that materials have been supplied as per technical specification, scope of work & approved drawings enclosing certified copy of inspection reports and dispatch clearances. (Material is to be delivered at the stores of contractor; however, the contractor shall update the concerned Nodal officer with the daily stock status)
 - iv. Copy of signed Contract Agreement with Discom.
- Note: [Two sets of above listed documents must be prepared & one copy be submitted to Payment Officer of Discom & second copy, duly verified from Engineer Incharge, to Nodal Officer along with bill of Payment claim as per SECTION - K: Format K.8].
- c) 2nd instalment of 50% of the supply value (inclusive of taxes) (for feeder completed) after receipt of claim (Installation, commissioning and testing) from the Contractor with following documents duly verified by Discom's concerned Nodal Officer/Engineer Incharge of Discom, will be made by Designated Payment Officer of Discom within 21 days from the date of submission of invoice along with relevant documents.
- i. Invoice issued by the Contractor & Duly Signed Installation Certificate as per SECTION - K: Format K.7
 - ii. Date of commissioning along with K.No. of Agriculture Consumer.

- iii. Model
- iv. Make
- v. Serial Nos. of PV modules, and Balance of systems.
- vi. Address proof of beneficiary like Ration Card, Aadhar card, Voters Identification Card number etc.
- vii. Two Photographs of beneficiary with installed system (The Photograph must match with the photograph in the ID proof). As far as possible, photograph of installed system shall be taken with person whose ID proof is being taken but in case at the time of taking Photograph the ID proof person is not available at his /her residence, spouse's photograph may be taken with installed system. The Contractor shall not display the photograph of the work and shall not take advantage through publicity of the work without written permission of Discom.
- viii. Copy of Agreement with beneficiary for maintenance (As per SECTION - K: Format K.3)
- ix. Copy of installation certificate duly signed (with seal) by the beneficiary and Engineer-Incharge designated by Discom. {As per SECTION - K: Format K.7 & K.4}.
- x. Signed Contract Agreement with Discom.

Note: [Two sets of above listed documents must be prepared & one copy be submitted to Payment Officer of Discom & second copy, duly verified from Engineer Incharge, to Nodal Officer along with bill of Payment claim as per SECTION - K: Format K.8 and these beneficiaries details should also be uploaded on Discom website].

- d) Balance 10% of the supply value (inclusive of taxes) for total contract will be released to the Contractor after 60 months of handing over the system after successful completion, commissioning and charging in all respect and also subject to clearance/ verification of 3rd party inspection.

(II) Erection value of the total contract

- a) 1st instalment of 90% of the erection value (inclusive of taxes) (for the feeder completed) after receipt of claim (Installation, commissioning and testing) from the Contractor with following documents duly verified by Discom's concerned Nodal Officer/Engineer In-charge of Discom, will be made by Designated Payment Officer of Discom within 21 days from the date of submission of invoice along with relevant documents.
 - i. Invoice issued by the Contractor & Duly Signed Installation Certificate as per SECTION - K: Format K.7
 - ii. Date of commissioning along with K.No. of Agriculture Consumer.
 - iii. Model
 - iv. Make
 - v. Serial Nos. of PV modules, and Balance of systems.
 - vi. Address proof of beneficiary like Ration Card, Aadhar card, Voters Identification Card number etc.

- vii. Two Photographs of beneficiary with installed system (The Photograph must match with the photograph in the ID proof). As far as possible, photograph of installed system shall be taken with person whose ID proof is being taken but in case at the time of taking Photograph the ID proof person is not available at his /her residence, spouse's photograph may be taken with installed system. The Contractor shall not display the photograph of the work and shall not take advantage through publicity of the work without written permission of Discom.
- viii. Copy of Agreement with beneficiary for maintenance (As per SECTION - K: Format K.3)
- ix. Copy of installation certificate duly signed (with seal) by the beneficiary and Engineer-Incharge designated by Discom. {As per SECTION - K: Format K.7 & K.4}.
- x. Signed Contract Agreement with Discom.

Note: [Two sets of above listed documents must be prepared & one copy be submitted to Payment Officer of Discom & second copy, duly verified from Engineer Incharge, to Nodal Officer along with bill of Payment claim as per SECTION - K: Format K.8 and these beneficiaries details should also be uploaded on Discom website].

- b) Balance 10% of the erection value (inclusive of taxes) for total contract will be released to the Contractor after 60 months of handing over the system after successful completion, commissioning and charging in all respect and also subject to clearance/ verification of 3rd party inspection.

2.1.5. Invoicing Pattern: The Contractor will directly supply and install the system to beneficiary through an invoice through the name of Contractor's (In case of JV, in name of any member of JV). The invoice shall clearly mention the full value of the system and tax components. Feeder wise payment claim by contractor with complete list of beneficiaries (with all details) connected on the same feeder shall be done. Contractor will submit claims enclosing one copy of sale invoice and Handing Over Note.

2.1.6. Delay in submission of bills to Payment Officer with the receipt of Discom's Engineer In-charge & list of beneficiaries after 30 days from scheduled date for completion of work as per schedule will attract Liquidated damages as mentioned in Clause H.10 of this Section.

H.3. The Contractor shall provide comprehensive maintenance services as under:

3.1.1. The Contractor shall develop office-cum-service centre at tehsil headquarters/ at local block level as asked by Discom in each operation district essentially and every beneficiary shall be well informed about the concerned office-cum-service centre for lodging their complaint.

3.1.2. The Contractor shall ensure half yearly routine maintenance of system. Contractor has to undertake to perform regular visit of his technician with necessary spare parts from the office-cum-Service centre established at various headquarters of the division to the beneficiary Sites selected for attending complaints and for doing regular maintenance of the system installed.

- 3.1.3. The office-cum-Service Centre shall have adequately trained staff available for repair and maintenance of Solar PV Systems, Inverters supplied and installed.
- 3.1.4. The office-cum-service centre shall be open for atleast 8 hours per day and 6 days a week excluding bank holidays.
- 3.1.5. Contractor shall ensure that necessary spares are always available with the office cum service centres to provide necessary after sales service to the beneficiary during the guarantee period.
- 3.1.6. **In line with maintenance and servicing report requirement (Format K.13), cleaning of dust from SPV panel shall be in scope of the contractor.**
- 3.1.7. Contractor need to have a dedicated mobile number which shall be readily available during its office hours and an e-mail ID for correspondence.

H.4. Resolving Complaints related to defects/ non-working / poor performance of the System:

- 4.1.1. In any case of breakdown/ any problem/defect in SPV system or whenever a complaint is lodged by the beneficiary, the contractor shall have to replace/repair the defect of the SPV system, resolve it and make the SPV system operative at site as per the Technical specifications, **within 72 hours** of the receipt of the complaint. In case of theft, the complaint is to be resolved within 15 calendar days provided theft is duly certified by the nodal officer.
- 4.1.2. **Logging of Complaint:**
 - a) The concern beneficiary may lodge their complaint for SPV system. The record of each and every complaint received and resolved, with down time and up time shall have to be maintained by the Contractor in register as well as computer based software and in mobile application.
 - b) These records shall have to be submitted to Discom Office weekly (for complaints received and resolved during the week) and monthly (comprising of all complaints received and resolved during the month). Such register shall be verified by Concerned Nodal Officers or TPIA.
- 4.1.3. While doing repairing or rectification work, the Contractor's technician or any person is not authorized to work on Discom's electric line of 11 KV and LT having potential danger of electricity.
- 4.1.4. If the down time period for any beneficiary complaint exceeds 72 hours (15 calendar days in case for theft cases) and the contractor fails to make the plant operational, a penalty for the time period exceeding 72 hours (15 calendar days in case for theft cases), as per the below mentioned schedule shall be deposited by the contractor to the concerned AO of circle / as decided by DISCOM.

Water pump capacity (in HP)	Penalty applicable (in INR per day)
3	140
5	235
7.5	355

- H.5. The loss in generation shall be decided on daily basis.

- H.6. For any system / consumer complaint, the maximum applicable amount as penalty against loss of generation shall not be more than 10% of the respective cost of the SPV system installed at the consumer premises.
- H.7. The Contractor shall be issued a notice to pay the applicable penalty within 7 days to the concerned AO of circle / as decided by DISCOM. If the Contractor fails to pay the penalty within notice period, the Discom shall encash the Performance Security immediately.
- H.8. Unless specified otherwise, In the event of breach of any of the conditions of the contract at any time on the part of Contractor, the contract may be terminated summarily by Discom without compensation to the Contractor and Performance Security will be forfeited and Discom will take action for debarring & blacklisting the firm.
- H.9. The price quoted for the systems must be including installation charges and comprehensive maintenance for 5 years charges and shall remain fixed and firm during the period of contract.

H.10. Liquidated Damages (LD)

10.1.1. The Works & required completion period under this clause of LD shall pertain to the works required as per the Completion Period as mentioned in SECTION - C:(1.1.6).

- a) If the Contractor fail to complete the works in the period specified in Contract, the Discom may at its discretion to allow an extension in time of completion, if the Contractor has applied in writing for extension not after the stipulated date of completion of work, subject to recovery of LD from the Contractor an agreed liquidated damages and not by way of penalty a sum equal to the following percentage from the amount payable by Discom [i.e. the amount of LD shall be calculated on the total payment payable by Discom] for quantity of systems which the Contractor has failed to supply for period of delay as stated below:-
- i. If the Contractor fails to comply with the mentioned Completion Period and in accordance with the norms for the whole of the SPV System, (or a part for which a separate time for completion is agreed) then the Contractor shall pay to the Discom a sum equivalent to a quarter of a percent (0.25%) of the Contract Price for the whole of the facilities, (or a part for which a separate time for completion is agreed) as liquidated damages for such default and not as a penalty, without prejudice to the Discom's other remedies under the Contract, for each week or part thereof which shall elapse between the relevant Time for Completion and the date stated in Handing Over Note of the whole of the work (or a part for which a separate time for completion is agreed) subject to the limit of ten percent (10%) of Contract Price for the whole of the facilities, (or a part for which a separate time for completion is agreed).
 - ii. However, if the Contractor completes the work for whole of the facilities within the contracted time period, the Discom may then refund back the LD which was deducted on account of delay in completion of a part of a work for which a separate time for completion is agreed.
 - iii. The Discom may, without prejudice to any other method of recovery, deduct the amount of such damages from any amount due or to become due to the Contractor. The payment or deduction of such damages shall not relieve the

Contractor from his obligation to complete the Scope of Work, or from any other of his obligations and liabilities under the Contract.

- 10.1.2. Nodal Officer, Discom may at its discretion to allow extension of time to complete the work after reviewing the causes of delay without LD as above.
- 10.1.3. LD excludes delay in the completion of the work due to unforeseen reasons beyond the control and without fault and negligence of the Contractor including (but not restricted to) act of God or public anomie action of Government in its sovereign capacity, floods, epidemics, strikes, lockouts, fires and accidents. In the event of any of the aforesaid contingencies Discom may be promptly kept informed by the Contractor by e-mail / followed by confirmation in writing with documentary proof within fifteen days of commencement and cessation of Force Majeure circumstances. Under such circumstances reasonable extension of time shall be granted by Discom. Application for such extension must be made after completion of work as per agreement.
- H.11. While making the purchases as envisaged in this Tender Document, the Discom may exercise its own discretion and if possible resort to limited tender system issuing short term notices irrespective of the value of tender. In all cases where orders are cancelled due to non-supply of stores, it will be treated as breach of contract and Discom shall take action accordingly. It is clarified that the Discom may resort to risk purchase without granting any extension.
- H.12. The bidders are required to study carefully the conditions of the tender document, the enclosed specifications and the relevant provision of the relevant BIS/MNRE specifications wherever necessary before submitting the proposal. Technical particulars of the material offered must comply with the enclosed specifications and the relevant provisions of the BIS/MNRE.
- H.13. Any changes in the constitution of the Bidder/ Contractor (In case of JV, change in constitution of JV or any of the JV Member) shall be notified forth with by the Bidder/ Contractor in writing to the JVVNL, as applicable and such change shall not relieve Bidder/ Contractor from any liability under the contract.
- H.14. The authorisation for installing SPV system can be repudiated at any time by the Discom if the systems are not supplied and installed to its satisfaction. The reasons for repudiation shall be recorded by Discom. In case of non-performance in any form and shape of the terms & conditions of the agreement, Discom has the sole discretion to cancel the authorisation pertaining to the supply and installation of systems.
- H.15. If a bidder imposes conditions, which are in addition to/or in contravention with the conditions mentioned herein, his tender is liable to be summarily rejected. In any case none of such conditions will be deemed to have been accepted unless specifically mentioned in the letter of authorisation issued by Discom.
- H.16. If any dispute arises out of the contract with regard to the interpretation / meaning and the breach of the terms of the contract, the matter shall be referred to by the parties to Managing Director, Discom whose decision shall be final and binding.

H.17. Inspection of Material

- 17.1.1. Prior to dispatch, the materials may be inspected and tested by respective Discom or TPIA, at the works of OEM (Original Equipment Manufacturer), where SPV (Solar Photovoltaic) panels, Grid tie Inverters, Module mounting structure, other components of the project are manufactured. The Contractor shall inform Discom for

such inspection at least 10 (ten) days in advance before the probable date of dispatch. Materials dispatched without Discom's approval shall not be accepted and the Discom shall have right to reject it and recover the cost so incurred from the contractor.

- 17.1.2. Cost of inspection: All the expenses related to inspection team like lodging, boarding, travelling, and air tickets to be borne by the Contractor. The Contractor will provide necessary inspection & testing facility at his cost.
- 17.1.3. However, if the material is not kept ready for inspection after intimation of the offered quantity on the scheduled date for inspection then all consequences will be to Contractor account and Discom will recover the re-inspection charges @ Rs. 15,000/- for outside Rajasthan State inspection and within Rajasthan State @ Rs. 7,500/-.
- 17.1.4. The Contractor will offer Solar PV Panels, BOS and components of system for inspection at the OEM works to Discom and inspection can also be offered at one place in Rajasthan (main distributor's place), where requisite inspection facilities are available. DISCOM reserves the right to inspect any number of SPV systems at OEM works at their discretion.
- 17.1.5. Systems installed under the allocated work in this tender shall meet technical specification and construction standards as specified by BIS and MNRE from time to time. Non-compliance will be taken seriously to the extent of blacklisting of the vendor, in the same manner as specified, apart from taking action under any other law in force. Evaluation of implementation of Component-C will be carried out through third party selected for this purpose. In order to ensure, the scheme meets expected outcomes continues evaluation of scheme would be undertaken and mid-course correction, as required, shall be implemented.
- 17.1.6. On Commissioning quality monitor as appointed under KUSUM Scheme, as applicable shall inspect the SPV system. Contractor shall provide all requisite details built drawings (in line with MNRE specifications in Annexure L.3 and Joint measurement sheet to the inspector to conduct. Contractor shall rectify defects/deficiencies and submit compliance to the observations with supporting photographs in digital form within one month from receipt of observations.
- 17.1.7. The inspection of materials and components of the project carried out by Discom's / MNRE / TPIA representative shall not relieve the Contractor from full responsibility of completing the project confirming to the requirement of the Contract.

H.18. Guarantee

- 18.1.1. The Grid connected SPV System for the Project supplied, installed and commissioned shall be guaranteed by the Contractor for a minimum period of 5-five years from the date of successfully commissioning of the last system, in regard to quality of design, survey, material, workmanship, quality of process/ manufacturing, performance, efficiency, installation, etc.
- 18.1.2. In the event any defect is found or developed in the system within guarantee period, shall be rectified/replaced by the Contractor at his own expense promptly.
- 18.1.3. In case the defects are not rectified within 72 Hours of the receipt of the complaint by the Contractor, Discom shall have full liberty to rectify such defect or undertake such repairs as may be necessary to restore the system in working condition at the risk and cost of the Contractor.

18.1.4. The expenditure so incurred by Discom shall be deducted from Contractor's pending claims, security, etc. and if necessary may be recovered in other mode provided under the law. In the event of failure of the complete SPV system, if necessary, the whole SPV system shall be replaced by the Contractor.

H.19. The Contractor will submit the manufacturer Warranty on NJS of Rs 500/- after LoA.

H.20. Any other item not specifically mentioned in the specifications but which are required for Supply, Installation, Testing and Commissioning of Distributed Grid connected SPV Systems for the project are deemed to be included in the scope of the specification as per relevant and latest IS, IEC, MNRE guidelines, standards of Rural Electrification Corporation (REC) and specified by Discom unless specifically excluded.

H.21. Specification of all the items covered under this Tender Document is given separately. However, if any item is left out, standard specification of relevant and latest IS, IEC, MNRE, Rural Electrification Corporation (REC) and specified by Discom will be applicable for the same.

H.22. System approval from the Nodal Officer

22.1.1. The concerned Nodal officer for the lot shall issue approval of all the distributed Grid connected SPV Systems for the purpose of energization of the SPV system.

H.23. On submission of Bid by bidder it will be deemed that Bidders have carefully read and understood the above terms & conditions of the tender document and agree to abide by them.

H.24. Original/attested photocopies of the latest Type test certificate(s) not older than 5 (five) years from MNRE approved / any recognized Government Laboratory, for all type tests wherever prescribed in the relevant latest edition of MNRE/BIS (as applicable) as mentioned in technical specification shall be furnished by the Contractor to Discom before commencement of work (supply of SPV systems). However the bidder shall have to furnish declaration to this effect with the Bid that in the event of Award of Work "they shall submit type test reports for approval". However, the Discom reserves the right to get type tests conducted afresh by the Contractor.

24.1.1. Discom may visit and inspect the manufacturing unit of every part /item of the SPV systems after issuance of Work Order or during implementation of the programme to ensure the status and infrastructure and process of quality control of product.

24.1.2. The Contractor shall be required to furnish the routine/manufacturer(s) factory test certificate(s) for the tests carried out during manufacture in accordance with the relevant standard specifications.

H.25. Protection of property

25.1.1. The Contractor shall be solely responsible for any damage resulting from his operations up to commissioning and handing over of the system. He shall also be responsible for protection of all persons including members of public and employees of the respective Discom and the employees of other Contractor and sub-Contractor and all public and private property including structures, building, other plants and equipment and utility either above or below the ground up to commissioning and handing over of the system.

- 25.1.2. The Contractor will ensure provision of necessary safety equipment such as barriers, signboards, warning lights and alarms, etc. to provide adequate protections to persons and property. The Contractor shall be responsible to give reasonable notice to the Engineer and the Discom of public or private property and utilities when such property and utilities are likely to get damaged or injured during the performance of his works and shall make all necessary arrangements with such employers, related to removal and / or replacement or protection of such property and utilities.
- 25.1.3. The contractor shall adopt and implement all required measures to ensure non tampering with any equipment or theft of electricity. This shall include but not limited to, installation of both the energy meters (solar meter and net meter) at adequate height with the metering console and proper sealing.

H.26. Work & Safety Regulations

- 26.1.1. The Contractor shall ensure proper safety of all the workmen, materials, plants and equipment belonging to him or to the Discom or to others, working at the site. The Contractor shall also be responsible for provision of all safety notices and safety equipment required both by the relevant legislations and the engineer, as they may deem necessary.
- 26.1.2. All equipment used in construction and erection by Contractor shall meet Indian/International standards and where such standards do not exist, the Contractor shall ensure these to be absolutely safe. All equipment shall be strictly operated and maintained by the Contractor in accordance with manufacturer's operation manual and safety instructions and as per guidelines / rules of the Discom in this regard.
- 26.1.3. The Contractor shall provide suitable safety equipment of prescribed standard to all employees and workmen according to the need.
- 26.1.4. The Contractor shall not interfere or disturb electric fuses, wiring and other electrical equipment belonging to the Discom under any circumstances, whatsoever, unless expressly permitted in writing by the Discom to handle such fuses, wiring or electrical equipment.
- 26.1.5. In case any accident occurs during the construction / erection or during guarantee period of 05 years for the activities undertaken by the Contractor thereby causing any minor or major or fatal injury to his employees / labourer due to any reason, whatsoever, it shall be the responsibility of the Contractor to promptly inform the same to the Engineer in charge of concerned Sub Division of Discom in prescribed form and also to all the authorities envisaged under the applicable laws. For any fatal / nonfatal accident to human or animal or any mishap within area of installation due to mishandling or reason whatsoever attributable to Contractor at the time of commissioning of SPV system, Contractor has to pay compensation as provided under the relevant applicable Act.
- 26.1.6. The Contractor shall follow and comply with the Discom's safety rules relevant provisions of applicable laws pertaining to the safety of workmen, employees, plant and equipment as may be applicable from time to time without any demur, protest or contest or reservations. In case of any discrepancy between statutory requirement and Discom's safety rules referred above, the latter shall be binding on the Contractor unless the statutory provisions are more stringent.
- 26.1.7. It will be the Contractor's sole responsibility to take the materials up to the installation site.

H.27. Repeat/ Additional Orders

27.1.1. JVVNL, as applicable, reserves the right to place repeat orders / additional orders on the Successful Bidder/ Contractor Agency up to 50% of the original quantity of the order at the same prices, terms and conditions stipulated in the original contract during contractual period.

H.28. Security

28.1.1. The Contractor shall have total responsibility for security of all equipment and materials in his custody/stores, loose, semi-assembled and/or erected by him at site. The Contractor shall make suitable security arrangements including employment of security personnel to ensure the protection of all materials, equipment and works from theft, fire, pilferage and any other damages and loss up to commissioning of the system.

H.29. Indemnity

29.1.1. The Contractor agrees to defend, indemnify and hold harmless the Discom, its officers, Directors, consultant, agents, employees and affiliates (and their respective officers, directors, agents and employees) from and against any and all claims, liabilities, actions, demands, judgments, losses, costs, expenses, suits, actions and damages arising by reason of bodily injury, death or damage to property sustained by third parties that are caused by an act of negligence or the willful misconduct of the Contractor, or by an officer, Director, agent or employee of the Contractor. Indemnity Bond, if applicable & required shall be submitted by Contractor.

29.1.2. Discom / beneficiaries will bear the cost of shifting of the system. In such cases, the guarantee will be continued as per Tender conditions.

H.30. Termination of Contract

30.1.1. In case, the Contractor fails to deliver the stores / materials / equipment or any consignment thereof within contractual period of delivery or in case the stores are found not in accordance with prescribed specification, Discom's reserves the right to terminate the contract OR Discom shall exercise its discretionary power either:

a. In case material is not found as per specification, Discom has right to seek replacement of the same material without any incremental cost to Discom's.

OR

b. To purchase from elsewhere after giving due notice to the Contractor on account and at the risk & cost of the supplier such stores not so delivered or other similar description without cancelling the contract in respect of the consignment not yet due for delivery

OR

c. to cancel the contract.

30.1.2. In the event of the risk purchase of stores of similar description, the opinion of Discom's shall be final. In the event of action taken under clause 30.1.1 (b) & (c) above, the Contractor shall liable to pay for any loss which Discom may sustain on that account but the Contractor shall not be entitled to any saving on such purchases made against default.

- 30.1.3. If the Contractor neglects to execute the work with due diligence and expedition or refuses or neglect to comply with any reasonable orders within two days of notice given in writing to the Contractor and if he fails to comply with the notice, then in such a case Discom shall be at liberty to get the work or any part of it as per 25.6 of this Section.
- 30.1.4. The decision of Discom's shall be final as regards the acceptability of stores supplied by the Contractor and Discom shall not be required to give any reason in writing or otherwise at any time for rejection of the stores.
- 30.1.5. Further, "Discom's reserves the right to terminate the Contract (i.e. Work order) at any time, without assigning any reasons, whatsoever, by giving a notice period of ONE month from the date of Notice of termination of the Contract. Contractors will not be entitled for any compensations / damages / losses, whatsoever, on account of such termination of the Contract.
- 30.1.6. In the event of termination of the agreement, Discom shall be at liberty to get the remaining part of the work done through any other agency at the risk and cost of the Contractor and in the manner and on the terms it thinks proper. If the cost of executing the work as aforesaid shall exceed the balance due to the Contractor, and Contractor fails to make good the deficiency, Discom may recover it from the Contractor in any lawful manner.
- H.31. The Contractor shall have to comply with all rules, regulations, laws and bylaws enforced by local, State Govt., Central Government and also the organization in whose premises the work has to be done.
- H.32. The Contractor shall not, without consent in writing of Discom, transfer, assign or sublet the work under this contract or any substantial part thereof to any other party.
- H.33. Discom shall have at all reasonable time access to the works being carried out by the Contractor under this contract. All the works shall be carried out by the Contractor to the satisfaction of Discom.

H.34. Discom's/ JVVNL Rights

- 34.1.1. Discom reserves the right to terminate the contract or part thereof at any time giving 01 (One) months' notice of Termination or the reasons thereof. Contractor/s will not be entitled for any compensation / damages / losses, whatsoever, on account of such termination of the Contract.
- 34.1.2. Discom will be entitled to deduct directly, from the bills to be paid to the Contractor, any sum or sums payable by him and which sum/sums due to the Contractor or the Discom is required to pay as a principal employer on account of Contractor's default in respect of all liabilities referred to.
- 34.1.3. The Contractor shall specifically note that any overwriting or corrections or manuscript in the offer shall be ignored and will not be considered authentic unless same are signed and Contractor's Stamp / Seal is affixed.
- 34.1.4. Discom/ JVVNL, as applicable, reserves the right to split the contract into two or more Agency per feeder. In such cases, the term for completion period will be negotiated and reduced proportionate to the offered quantity / value.
- 34.1.5. In case of any doubt or interpretation of the terms and condition, the decision of the JVVNL as applicable will be final and binding upon the Contractor and no dispute in this regard will be entertained.

34.1.6. JVVNL reserves the right to accept any offer or reject any or all Bids or cancel / withdraw or re invitation to offer without assigning any reason. Such decision of the JVVNL shall not be subject to question by any Bidder and the JVVNL shall bear no liability whatsoever for such decision.

34.1.7. JVVNL has right to make minor changes / modifications in the Technical & Site condition matter. In such matter, decision of JVVNL as applicable shall be final and binding to the Contractor to carry out work accordingly.

H.35. Completion of Contract

35.1.1. Unless otherwise terminated under the provisions of any other relevant clause, this Contract shall be deemed to have been completed on the expiry of the Comprehensive Maintenance during guarantee period.

H.36. Packing and forwarding charges

36.1.1. The quoted prices by Bidders shall be inclusive of packing & forwarding charges. The stores shall be strongly and adequately packed to ensure safe arrival at destination. The materials dispatched from overseas by Air / Shipping shall be packed in such a way that it can withstand rough handling and possible corrosion due to exposure to salt laden atmosphere, salt spray or open storage. All packing must be clearly marked with order Number and consignee's name and address.

H.37. Insurance

37.1.1. Transit Insurance

All the materials under the Solarization part will be required to be supplied up to farmer's site and shall have transit insurance against all transit risks, such as damage, loss, theft, fire, etc. The transit insurance period shall cover 60 days after the date of receipt of materials at destination to enable Discom to check the stores fully. The cost of damaged, defective stores materials will however be deducted from the bills of the suppliers and will be refunded only after replacement thereof. It will be the responsibility of the supplier to lodge claim against the insurance on receiving necessary advice from the consignee. Transit Insurance of the material shall remain the responsibility of the Contractor till the time of Commissioning.

37.1.2. Insurance for Five Years:

- a) The Contractor has to take the insurance for the whole Solar PV systems with inverter supplied and installed by them as per the Solarization part well as the metering system supplied by third party for the risk covering, theft, damage, fire and damage or loss due to natural calamities for five years from the date of commissioning of the last system of the project.
- b) The Contractor shall file insurance claim and shall be responsible to bring an insurance claim to a final settlement. And in such cases the Contractor has to restore the whole Solar PV system with inverter in working condition within 15 (fifteen) calendar days without waiting for settlement of insurance claim. Insurance coverage for 5(five) years is compulsory.
- c) The Contractor shall get the solar system insured and submit the Insurance Policy jointly in the name of the contractor and beneficiary, covering risks as mentioned above for the period of five years to Discom immediately after commissioning of

the project, failing which, the payment towards installation and commissioning part will not be released until production of the insurance.

H.38. Acceptance of Stores

38.1.1. All or any stores and materials to be supplied at F.O.R. Destination (Farmer's site), against this contract will be subject to their acceptance by the consignee or any Authorized Officer deputed by Discom for this purpose. Discom will be at liberty to reject whole lot without assigning any reasons and the decision of the Officer concerned will be considered as final.

H.39. Taxation

39.1.1. Goods and Service Tax (GST):

- a) The F.O.R. Destination prices are excluding GST and Cess as applicable which will be paid extra on a given taxable goods and/or services. The amount and % of GST and Cess as applicable shall clearly be indicated separately. (GST/Cess means all applicable Tax/Cess under GST Laws. GST Laws means IGST Act, GST (Compensation to the State for Loss of Revenue) Act, CGST Act, UTGST Act and SGST Act, 2017 and all related ancillary legislations).
- b) Contractor shall have to submit a C.A Certificate (to be submitted on CA letterhead) & duly authorized Signatory of Contractor, certifying that you have not claimed Refund of any applicable GST and Cess, charged to Discom or shall not claim any such Refund, on a future date, from the concerned Authorities and if, any Refund, in respect of such GST and Cess, is claimed by you, it will be immediately passed on to the Discom, without Discom making any specific Claim, for the same, either from the GST Department or from you.
- c) The Price Bids having price INCLUSIVE OF GST and Cess is likely to be rejected if the rate of GST and Cess is not mentioned clearly unless the Contractor has opted for Composition Scheme under GST Act, which shall be clearly indicated in the price Bid. Discom may at its discretion consider such offer with presumption of highest applicable rate of GST/Cess prevailing when the price quoted is inclusive of GST and Cess.
- d) If the Contractor has opted for the Composition scheme of GST, the same must be clearly specified with valid Declaration & Certificate from Department. In the event of withdrawal/cessation of the Contractor from Composition scheme during the tenure of the contract, the rate mentioned in the price bids shall be final and any additional GST will have to be borne by the Contractor. In no case additional amount towards tax or otherwise will be paid / reimbursed to Contractor. Further Statutory Variation clause will not be applicable in case of Contractor has opted for Composition Scheme under GST.
- e) Contractor shall charge GST in Invoice at the rate as agreed to / mentioned in acceptance of Tender Document only and any deviation in the same shall not be accepted. Further, any additional liability of GST (later on due to wrong mentioning of GST rate, mis-interpretation of HSN/SAC Code, etc.) over and above as charged in the invoice shall be borne by the Contractor.
- f) However, any refund received by the Contractor on account of GST charged from the Discom; such refund shall have to be passed on to the Discom, along with

interest if any. Such refund along with interest needs to be passed on suo-moto by the Contractor.

- g) Further, the Discom has a right to recover the amount of GST along with penal interest at the rate of 15% per annum if GST charged is not paid / short paid to the Government or fail to upload the details or uploads inaccurate particulars on GSTIN portal by the Contractor within the stipulated time limit. In case, Govt. revises the rate of GST rate / Code during the tenure of the contract, the provision of Discom's statutory variation clause shall apply.

39.1.2. Input Tax Credit Benefit

- a) In the event of any statutory increase in the rate of Input Tax Credit and / or due to inclusion of any other additional item of their inputs / input services under the ambit of the Input Tax Credit provisions under the GST Act, subsequent to the date of submission of the Price Bids, the same shall be passed on to Discom by Contractor and Contractor shall inform such changes to Discom from time to time.

39.1.3. Statutory Deduction

- a) Statutory deduction will be made as per applicable rules & rates for TDS, Worker welfare cess, or any other taxes applicable time to time etc. All other statutory liabilities towards this contract will be on the part of Contractor.

H.40. Unloading

40.1.1. Unloading of the materials at farmer's site shall be arranged by the Empanelled Agency.

H.41. Statutory variation

41.1.1. Any statutory increase or decrease in the taxes and duties including GST and Cess as applicable or in the event of introduction of new tax/cess or cessation of existing tax/cess subsequent to submission Price Bids by Bidders if it takes place within the original contractual delivery date will be to Discom's account subject to the claim being supported by documentary evidence. However, if any decrease takes place after the contractual delivery date, the advantage will have to be passed on to Discom. Statutory Variation clause will not be applicable in case of Contractor has opted for Composition Scheme under GST.

H.42. Random Checking of Material at Site

42.1.1. From the lots inspected by the Discom Inspector, the Inspector of designated Wing, Discom if required, may pick up samples from the lots supplied & Installed at beneficiaries' site at random for quality check only. The samples picked up will be tested for acceptance test as decided by Discom at MNRE/ Government approved laboratory in presence of representatives of Contractor and Discom as per relevant IEC/ISS/BIS/ Discom specifications. The test results will be binding on the Contractor and Discom, in general will not allow re-sampling. If the material fails in any of the acceptance tests carried out, the full lot of materials will be considered as rejected. The decision in this regard for acceptance as above of Discom shall be final and this will be binding on the supplier.

H.43. Jurisdiction of Contract

43.1.1. The laws applicable to the Contract shall be the Laws in force in India. The court at respective District of Corporate Office of respective Discom shall have exclusive jurisdiction in all matters arising under this contract.

H.44. The Bidder shall sign these conditions on each page at the end in token of acceptance of all the terms and it would be attached /uploaded with the proposal along with the declaration. He shall also sign with seal at the bottom of each of the pages of his tender.

H.45. Contract Documents

45.1.1. Subject to the order of precedence set forth in the Agreement, all documents forming the Contract (and all parts thereof) are intended to be correlative, complementary, and mutually explanatory.

H.46. Interpretation

46.1.1. If the context so requires it, singular means plural and vice versa.

46.1.2. Commercial Terms: The meaning of any trade term and the rights and obligations of parties there under shall be as prescribed by commercial terms. All the terms shall be governed by the rules prescribed in the current edition of commercial terms, published by the Indian Chamber of Commerce at the date of the Invitation for Bids or as specified in the bidding document.

46.1.3. Entire Agreement: The Contract constitutes the entire agreement between the Purchaser and the Supplier and supersedes all communications, negotiations and agreements (whether written or oral) of parties with respect thereto made prior to the date of Contract.

46.1.4. Amendment: No amendment or other variation of the Contract shall be valid unless it is in writing, is dated, expressly refers to the Contract, and is signed by a duly authorized representative of each party thereto.

46.1.5. Non-waiver: Subject to the condition vi below, no relaxation, forbearance, delay, or indulgence by either party in enforcing any of the terms and conditions of the Contract or the granting of time by either party to the other shall prejudice, affect, or restrict the rights of that party under the Contract, neither shall any waiver by either party of any breach of Contract operate as waiver of any subsequent or continuing breach of Contract.

46.1.6. Any waiver of a party's rights, powers, or remedies under the Contract must be in writing, dated, and signed by an authorized representative of the party granting such waiver, and must specify the right and the extent to which it is being waived.

46.1.7. Severability: If any provision or condition of the Contract is prohibited or rendered invalid or unenforceable, such prohibition, invalidity or unenforceability shall not affect the validity or enforceability of any other provisions and conditions of the Contract.

46.1.8. In case of any ambiguity in the interpretation of provision mentioned in the tender document than decision of MNRE/ Discom shall be final. Further, the provision contained in RTPP Act 2012 and RTPP Rules 2013 shall prevail wherever applicable.

H.47. Change in Laws & Regulations

- 47.1.1. Unless otherwise specified in the Contract, if after the date of the submission of bids, any law, regulation, ordinance, order or bylaw having the force of law is enacted, promulgated, abrogated, or changed in Rajasthan/ India, where the Site is located (which shall be deemed to include any change in interpretation or application by the competent authorities) that subsequently affects the Deployment Date and/ or the Contract Price, then such Deployment Date and/ or Contract Price shall be correspondingly increased or decreased, to the extent that the Contractor has thereby been affected in the performance of any of its obligations under the Contract.
- 47.1.2. Notwithstanding the foregoing, such additional or reduced cost shall not be separately paid or credited if the same has already been accounted for in the price adjustment provisions where applicable, in accordance with clause “Contract Price”.

SECTION - I: DETAILED SCOPE OF WORK AND TECHNICAL SPECIFICATIONS

I.1. Detailed Scope of Work

I.1.1. Overall Scope

- a) Jaipur Vidyut Vitran Nigam Limited (JVVNL) hereby invites through short-term NIT, bids from eligible bidders for the work of design, survey, supply, installation, testing, commissioning & 5 years comprehensive maintenance of distributed grid connected solar PV systems for solarization of grid connected agriculture consumers under “KUSUM Scheme – Component C” in Jaipur DISCOM.
- b) The Bidder shall be responsible for acquainting oneself with all terms and conditions of this Tender document, site location(s) and conditions prior to quoting. In case of any safety or compliance issues foreseen by the Bidder, the same shall be immediately reported by the Bidder to JVVNL.
- c) For effective management of the project, **feeder-wise implementation** is to be carried out for solarisation of grid connected agricultural pumps. Feeders may be selected based on load, technical and commercial losses, number of consumers, etc. Contractor shall ensure that all identified sites of agriculture pumps (as per the work area / site locations listed in this tender) in a feeder are solarized before proceeding the work on to the next feeder.
- d) The solar PV plants shall consist of complete system including PV modules, grid-tie inverters, SPV controller, module mounting structures (MMS), AC and DC junction boxes, solar meter, net-meter, cables, earthing, lightning protection, associated civil works, and accessories as described in this section.
- e) The capacities of the solar PV plants shall have three SPV system unit sets 4.5 kWp, 7.5 kWp & 11.25 kWp. The capacity of the PV plant shall be based on the existing sanctioned load of the Agriculture Consumer as described in this section.
- f) All components and works shall adhere to relevant Indian Standards, State and Central policies and regulations, and all statutory provisions under the Indian law.
- g) Contractor shall adhere to all Boundary Conditions described in this section including but not limited to outreach and handholding of Agriculture Consumers on the given feeder; integrating the Contractor’s own Scope of Work with the supplier of the metering and communicating equipment; obtaining insurance on the PV system including metering set; and so on.
- h) The Contractor shall be entirely responsible for the execution of the Scope of Work in accordance to this Tender Document including but not limited to its specification, schedules, and annexure. The Contractor shall further provide guarantee and be responsible for the quality and workmanship of all materials and completed works, survey, correct designs and drawings (in line with MNRE specifications in Annexure L.3, correct delivery of material, erection, testing, commissioning and comprehensive maintenance
- i) The Contractor shall be responsible for undertaking all applications and obtaining all approvals, permissions, etc. in order to successfully complete the Scope of Work. In cases where Discom’s certifications are required, the Contractor shall inform the Discom and provide the requisite formats for such certificates well in advance.

- j) The Contractor shall provide a generation guarantee and maintain an active local office cum service center in each operation district where work is carried on under this tender, to rectify faults within the stipulated timeframe described in this section.
- k) The Contractor shall adhere to best practices in terms of safety, quality and performance while undertaking the Scope of Work, and the same shall be included within the Contractor's contract price.
- l) The Contractor shall repair at its own cost any damage caused to the Discom's premises due to implementation of the Scope of Work.
- m) Submission of brochures, technical specifications, designs, data sheets, etc. at the time of Bidding do not imply approval of the same. All such approvals shall be taken up separately at the time of project execution by the Contractor from the Discom.
- n) All final specifications, designs, drawings (in line with MNRE specifications in Annexure L.3), bill of material, quality assurance plan, etc. shall be inspected, vetted and approved by the Discom or the TPIA.
- o) It is mandatory for Contractor to provide for Comprehensive Maintenance Contract (CMC) for five years from the date of commissioning of the last system of total awarded work or, 9 month from the date of award of work (LoA), whichever is later, helpline, district level office cum service center and comply standards of performance in dealing with complaints.
- p) It will be mandatory for Contractor to create remote monitoring system to monitor performance of the system post-installation. Detailed specifications of Remote Monitoring System (RMS) enclosed as **Section L.2**. It will be mandatory to submit quarterly maintenance report along with performance data of solar power plant online to MNRE and/ or Discom in a manner and format prescribed by MNRE and/ or Discom.
- q) It will be mandatory to use indigenously manufactured solar panels with indigenous solar cells and modules. To ensure the same, submission of authorization or DCR certificates from Indian cell supplier(s) will be mandatory. Domestic manufacturing of solar cells and panels will also be ensured through inspection and verification at module manufacturing unit of the respective OEM. Further, inverters/controllers and the balance of system should also be manufactured indigenously. If required, MNRE may conduct its independent inspection or verification to ensure domestic manufacturing requirement. The contractor has to declare the list of imported components used in the solarisation system.
- r) Systems installed under this Scheme shall meet technical specification and construction standards as specified by BIS and MNRE from time to time. Non-compliance will be taken seriously to the extent of blacklisting of the Contractor, in the same manner as specified, apart from taking action under any other law in force.
- s) Survey shall include assessing the works/approvals required on the Sites/ location of the list of agriculture consumers which will be provided by Discom and getting consent from agricultural consumers for solarization of water pumps.
- t) Format of Guarantee card is attached at SECTION - K: (Format K.12).
- u) The contractor shall adopt and implement all required measures to ensure non tampering with any equipment or theft of electricity. This shall include but not limited

to, installation of both the energy meters (solar meter and net meter) at adequate height with the metering console and proper sealing.

- v) In line with maintenance and servicing report requirement (Format K.13), cleaning of dust from SPV panel shall be in scope of the contractor.

1.1.2. Obligation towards Agriculture Consumers

- a) It shall be the prime responsibility of the Contractor to manage all Agriculture Consumers connected to the Agriculture Feeder assigned to the Contractor.
- b) The Contractor shall directly deal with the Agriculture Consumers on a regular basis to:
- i. Educate, create awareness and market the Scheme to the Agriculture Consumers,
 - ii. Obtain all necessary approvals, permissions, etc. towards installation and commissioning of the PV system on behalf of the Agriculture Consumer,
 - iii. Obtain the necessary insurance on the PV system on behalf of the Agriculture Consumer to comply with loan guidelines,
 - iv. Coordinate successful operation and maintenance of the PV system.
- c) The Contractor shall identify a suitable location for the installation of the PV system within the premises of the Agriculture Consumer. This location shall be identified in close coordination with Discom Official and agreement of the Agriculture Consumer in writing. The cable routing of the PV system shall also be mutually agreed upon by the Contractor, Discom Official and the Agriculture Consumer in writing. The Scope of Work includes AC cabling for a distance between the inverter and interconnection point.
- d) The Contractor shall provide prompt service to the Agriculture Consumer in times of fault of breakdown of the PV system. Any complaint received from the Agriculture Consumer/ Discom shall be rectified by the Contractor within 72 (seventy two) hours of such complaint. In case of theft, the complaint is to be resolved within 15 calendar days provided theft is duly certified by the nodal officer. If the down time period for any beneficiary complaint exceeds 72 hours (15 calendar days in case for theft cases) and the contractor fails to make the plant operational, a penalty for the time period exceeding 72 hours (15 calendar days in case for theft cases), as per the below mentioned schedule shall be deposited by the contractor to the concerned AO of circle / as decided by DISCOM.

Water pump capacity (in HP)	Penalty applicable (in INR per day)
3	140
5	235
7.5	355

- I.2. The loss in generation shall be decided on daily basis.
- I.3. For any system / consumer complaint, the maximum applicable amount as penalty against loss of generation shall not be more than 10% of the respective cost of the SPV system installed at the consumer premises.
- I.4. The Contractor shall be issued a notice to pay the applicable penalty within 7 days to the concerned AO of circle / as decided by DISCOM. If the Contractor fails to pay the

penalty within notice period, the Discom shall encash the Performance Security immediately.

4.1.1. Interfacing with Metering and Communication Solution Provider

- a) The Contractor shall work in close coordination with the M&P Wing of Discom / IT Wing of Discom/ Billing agency of Discom/ or any other agency assigned by the Discom.
- a) Detailed specifications of Remote Monitoring System (RMS) of MNRE enclosed as **Section L.2** and any further amendment(s) issued by MNRE shall be used by bidder for the purpose of metering and communication.
- b) The Contractor shall install the hardware including but not limited to energy meters and communication gateway (data logger, modem and antenna) provided in an enclosure to be provided by the Contractor. The GPRS sim shall be provided by the Contractor and maintain the sim for complete 5 year maintenance period at its own cost.
- c) The Contractor shall mount this hardware as per Discom's standards, make appropriate connections to this hardware with respect to power cables and communication cables.
- d) The Contractor shall connect all its inverters to the appropriate interconnection point within the hardware via a shielded RS-485 communication cable. The Contractor shall ensure appropriate cable laying standards for both power cable(s) and RS-485 cable(s). The Contractor shall ensure avoidance of signal attenuation within the RS-485 cable and install repeaters if required.
- e) The Contractor shall only utilize grid-tie inverters with Modbus communication capability via RS-485 serial port, and share the details of the protocol with the M&P Wing of Discom / IT Wing of Discom/ Billing agency of Discom/ or any other agency assigned by the Discom. Further, the Contractor shall assist the M&P Wing of Discom / IT Wing of Discom/ Billing agency of Discom/ or any other agency assigned by the Discom to ensure successful communication of the inverter data to the designated server by the Discom.
- f) The Contractor shall assist the M&P Wing of Discom / IT Wing of Discom/ Billing agency of Discom/ or any other agency assigned by the Discom in case any hardware adjustments are required by the M&P Wing of Discom / IT Wing of Discom/ Billing agency of Discom/ or any other agency assigned by the Discom or if any support is required during configuration of the inverter communication or commissioning of the metering and communication hardware.
- g) Net-Meter: The bi-directional Smart energy meter shall be installed for the measurement of import/Export of energy, as per relevant specifications by MNRE/ CEA/Discom. Detailed indicative specifications shall be shared with successful bidder.
- h) Solar Meter: Uni-directional Smart energy meter shall be installed to log the actual value of Energy generated by the PV system be provided, as per relevant specifications by MNRE/ CEA/Discom. Detailed indicative specifications shall be shared with successful bidder.

- i) All parameters of the meter shall be transferred online to the M&P Wing of Discom / IT Wing of Discom/ Billing agency of Discom/ or any other agency assigned by the Discom.

4.1.2. Insurance during Construction of PV system

- a) During the construction period, i.e. before the commissioning of the PV system, all insurance-related expenses shall be borne by the Contractor. The goods supplied by the Contractor shall be fully insured against the loss or damage incidental to manufacture or acquisition, transportation, storage, delivery, theft, natural or other disaster/calamity, etc.
- b) In case of any loss or damage or pilferage or theft or fire accident or natural calamity or combination of the said incidents under the coverage of insurance, the Contractor shall lodge the claim as per rules of insurance. Any FIR required to be lodged at the local Police Station shall be the responsibility of the Contractor.
- c) The Contractor shall arrange to supply/ rectify/ recover the materials even if the claim is unsettled for timely completion of the Project. The final financial settlement with the insurance company shall be rested upon the Contractor.

4.1.3. Insurance during Operation of PV system

- a) Upon commissioning of the PV system, the Contractor shall undertake insurance on the PV system against theft and vandalism and natural calamities for a minimum period of 5 (five) years and include the same within the quoted cost.
- b) The insurance shall comply with terms and conditions of the loan obtained from the financial institution.
- c) The metering and communication hardware supplied by Contractor shall also be covered under the insurance by the Contractor at the Contractor's cost.
- d) The Contractor shall assist the Agriculture Consumer for insurance claims during the 5 (five)-year comprehensive maintenance period.
- e) At least 2 months before the end of the term of insurance undertaken by the Contractor, the Contractor shall ensure to provide all the necessary documents & guidance to the satisfaction of the Agriculture Consumer in order to enable the Agriculture Consumer, in case he wants to renew or to take up the insurance of the PV system at the end of the term of Insurance.

I.5. Technical Specifications

5.1.1. PV System Capacity

- a) The AC and DC Capacity of the grid-connected PV system shall be based on the sanctioned load of the Agriculture Consumer's pump connection. In case the Agriculture Consumer is applying addition/ alteration in sanctioned load, prior to installation of the PV system, then the Contractor shall size the PV system based on the revised capacity of the connection as confirmed by the Discom.
- b) The AC and DC Capacity of the PV system shall be based on the pump connection capacity as follows (i.e. as per MNRE guideline):

S.No.	Sanctioned Load	Minimum AC (Invertor) Capacity	Minimum DC (PV Module) Capacity
	(HP)	(kW)	(kW @STC)
1.	3	4.5	4.5
2.	5	7.5	7.5
3.	7.5	11.25	11.25

I.6. Applicable Standards

6.1.1. Table of Applicable Standard with description

Sr. No.	Applicable Standard	Description
1.	Solar PV Modules	
(a)	IEC 61215/IS 14286	Design qualification and type of approval for crystalline silicon Terrestrials photovoltaic Modules
(b)	IEC 61853-1/IS 16170-1	Photovoltaic (PV) module performance testing and energy rating-Irradiance and temperature performance measurements and power rating
(c)	IEC 61730-1,2	Photovoltaic (PV) Module safety Qualifications
(d)	IEC 62759-1	Photovoltaic (PV) modules - Transportation testing
(e)	IEC 61701:	Salt Mist Corrosion Testing of Photovoltaic (PV) Modules
(f)	IEC 62716:	Photovoltaic (PV) Modules – Ammonia (NH ₃) Corrosion Testing (As per the site condition like dairies, toilets)
2.	Solar PV Grid-tie Inverters	
(a)	IEC 62109-1,2	Safety of power converters for use in photovoltaic power systems
(b)	BS EN 50530:2010 + A1:2013 /IEC 62891	Overall efficiency of grid connected photovoltaic inverters
(c)	IEC 61683	Photovoltaic Systems –Power conditioners: Procedure for Measuring Efficiency (10%, 25%, 50%, 75% & 90-100% Loading Conditions)

Sr. No.	Applicable Standard	Description
(d)	IEC 62116/UL 1741/IEEE 1547	Utility-interconnected inverters - Test procedure of islanding prevention measures
(e)	VDE V 0126-1-1	Automatic disconnection device between a generator and the public low-voltage grid
(f)	IEC 60255-27:2013	Measuring relays and protection equipment - Part 27: Product safety requirements
(g)	IEC 60068-2(1,2,14,27,30,64)	Environmental testing of PV system –Power Conditioners and inverters
(h)	IEC 62093	Balance-of-system components for photovoltaic systems - Design qualification natural environments
3.	Fuses and switches	
(a)	IS/IEC 60947(1,2,3), EN 50521	General Requirements for connectors, switches, circuit breakers(AC/DC)
(b)	IEC 60269-6	Supplementary requirements for fuse-links for the protection of solar photovoltaic energy systems
4.	Cables	
(a)	IEC 60227/IS694, IEC 60502/IS 1554 (1,2)	General Test and measuring method for PVC insulated cables
(b)	IS 7098-1	Cross linked polyethylene insulated PVC sheathed cables up to 1000 V
(c)	BS EN 50618	Electric cables for photovoltaic systems, mainly for DC cables
5.	Surge Arrestors	
(a)	IEC 61643-11/IS 15086-5	Low voltage surge and protection devices, requirements and test methods
(b)	BFC 17-102:2011	Lightening Protection Standard
6.	Earthing/ Lightning	
(a)	IEC 62561 (1,2,7)	Lightning protection system components
(b)	IS 2309	Protection of Buildings and Allied Structures Against Lightning
7.	Junction Boxes	
(a)	IEC 60529	Degree of protection provided by the enclosure
8.	Smart Solar Meter	As per relevant specifications by MNRE/ CEA/Discom. Detailed indicative specifications shall be shared with successful bidder.
9.	Smart Net Meter	As per relevant specifications by MNRE/ CEA/Discom. Detailed indicative specifications shall be shared with successful bidder.
10.	PV Mounting structure	
(a)	IS 2062/IS 4759	Material for the structure mounting

6.1.2. If the equipment offered by the Contractor conform to other standards, salient points of difference between the standards adopted and the specific standards shall be clearly

brought out in relevant schedule. In case of any difference between provisions of these standards and provisions of this specification, the provisions contained in this specification shall prevail. One hard copy of such standards with authentic English Translations shall be furnished for consideration of such approvals.

I.7. PV Modules

- 7.1.1. The Contractor shall employ solar PV module of mono/ poly-crystalline silicon solar technology only. The Contractor shall provide detail Technical Data Sheets, Certifications of Standard Testing Conditions (STC: defined as Standard Testing Condition with air mass AM1.5, irradiance 1000W/m², and cell temperature 25°C) as per the latest edition of IEC 61215 and IEC 61730 and as tested by MNRE/IEC-recognized test laboratory.
- 7.1.2. The PV modules to be employed shall be indigenously manufactured and shall fulfil MNRE's criteria of domestic content requirement to avail its capital subsidy as per Scheme. The manufacturer of the PV module shall have supplied net PV modules of a capacity more than 5 MW in other projects, and the same shall be successfully performing for over 1 year prior to the date of submission of the Bid.
- 7.1.3. PV modules shall consist of 60 or 72 numbers of solar cells, each with a dimension of 156 mm x 156 mm. PV modules with 60 cell configuration shall have a minimum capacity of 250 W at STC, while PV modules with 72 cell configuration shall have a minimum capacity of 300 W at STC.
- 7.1.4. The rated power of solar PV module shall have maximum tolerance upto +3%. No negative tolerance in the rated capacity of solar PV module is allowed.
- 7.1.5. All PV modules shall be certified IEC 61215 2nd Ed. (Design qualification and type approval for Crystalline Si modules), IEC 61730 (PV module safety qualification testing @ 1000 V DC or higher).
- 7.1.6. Minimum certified PV module efficiency shall be 15% for crystalline. The temperature co-efficient power of the PV module shall not be less than -0.50% / °C.
- 7.1.7. All PV modules shall carry a performance warranty of >90% during the first 10 years, and >80% during the next 15 years. Further, module shall have performance warranty of >97% during the first year of installation. Degradation of module shall not be more than 0.7% per annum.
- 7.1.8. All PV modules shall be PID-free, and documents for the same shall be submitted with conditions of the PID test for a humidity of 85 % and a cell temperature of 850 C at 1000VDC.
- 7.1.9. The warranty on the workmanship of the PV modules including its electrical connections and mechanical construction shall be at least for 5 (five) years.
- 7.1.10. The mismatch losses for PV modules connected to an inverter shall be less than 1%.
- 7.1.11. PV module shall have module safety class-II and shall be highly reliable, light weight and must have a service life of more than 25 years.
- 7.1.12. The PV modules shall be equipped with IP67 or higher protection level junction box with a minimum of 3 (three) numbers of bypass diodes of appropriate rating

and appropriately sized output power cable of symmetric length with MC4 or equivalent solar connectors.

- 7.1.13. The SPV module shall be made up of high transmissivity glass and front surface shall give high encapsulation gain and the module shall consist of impact resistance, low iron and high transmission toughened glass. The module frame shall be made of corrosion resistant anodized aluminium, which shall be electrically compatible with the structural material used for mounting the modules.
- 7.1.14. The PV modules shall have suitable encapsulation and sealing arrangements to protect the silicon cells from environment. The encapsulation arrangement shall ensure complete moisture proofing for the entire life of PV modules.
- 7.1.15. The PV module frame shall be made of aluminium or corrosion resistant material, which shall be electrolytically compatible with the structural material used for mounting the PV modules.
- 7.1.16. All materials used for manufacturing solar PV module shall have a proven history of reliability and stable operation in external applications. It shall perform satisfactorily in temperature between -40°C to $+85^{\circ}\text{C}$ and shall withstand adverse climatic conditions, such as high speed wind, blow with dust, sand particles, saline climatic/ soil conditions.
- 7.1.17. Modules only with the same rating and manufacturer shall be connected to any single inverter.
- 7.1.18. The Bidder shall provide in the Bid power performance test data sheets of all modules. The exact power of the module shall be indicated if the data sheet consists of a range of modules with varying output power.
- 7.1.19. Discom or the TPIA reserves the right to inspect the PV modules at the manufacturer's site prior to dispatch.
- 7.1.20. The Contractor would be required to maintain accessibility to the list of module IDs/ serial numbers along with the parametric data for each module.
- 7.1.21. Modules deployed must use a RF identification tag. The following information must be mentioned in the RFID used on each module (This should be inside the laminate only and must be able to withstand harsh environmental conditions).
 - a) Name of the manufacturer of the PV module
 - b) Name of the manufacturer of Solar Cells.
 - c) Month & year of the manufacture (separate for solar cells and modules)
 - d) Country of origin (separately for solar cells and module)
 - e) I-V curve for the module Wattage, I_m , V_m and FF for the module
 - f) Unique Serial No and Model No of the module
 - g) Date and year of obtaining IEC PV module qualification certificate.
 - h) Name of the test lab issuing IEC certificate.
 - i) Other relevant information on traceability of solar cells and module as per ISO 9001 and ISO 14001

I.8. Grid-tie Inverter

- 8.1.1. Specifications for SPV water pumping systems of MNRE vide Circular No. F. No. 41/3/2018-SPV Division dated 17.7.2019 enclosed as **Section L.3** and any further amendment(s) issued by MNRE, shall be applicable under this tender.
- 8.1.2. Make of only those Grid-tie Inverters which are commissioned for more than 1 MW capacity in other solar PV projects in India and operational for more than 1 (year) shall be considered.
- 8.1.3. The Contractor shall provide sufficient information for the satisfaction of Discom prior placing the order for the inverters.
- 8.1.4. All inverters shall consist of associated control, protection and data logging devices and remote monitoring hardware, software for string level monitoring.
- 8.1.5. Capacity of single unit of inverter shall be at least 4.5 kW.
- 8.1.6. Inverter shall conform to the following details:

S. No.	Particulars	Details
1	Nominal AC Output Voltage	As per the manufacturer's guidelines
2	Type of solar charge controller	415 VAC \pm 15%, 3 phase, 50 Hz
3	Switching Devices	MPPT-based Solar Charge Controller
4	Maximum Input Voltage	MOSFET/ IGBT-based
5	Output Waveform	Not more than 1000 VDC
6	DC voltage range, MPPT	Pure Sine wave
7	Peak Efficiency	As per design
8	Euro Efficiency	At least 97%, measure as per IEC 61683
9	Output frequency	At least 96%, measure as per IEC 61683
10	Power Factor	50 Hz +3% to - 5% Hz
11	Maximum THD at rated power	0.8 lag- 0.8 lead
12	Ambient dry bulb temperature range	\leq 3 % 0 to 50° deg C
13	Humidity	15% to 95 % non- condensing
14	Enclosure	At least IP21 for indoor installation, At least IP65 for outdoor installation, as per IEC-60068-2 (environmental)
15	Protection rating (as per IEC-60721-3-3)	Classification of chemically active substances: 3C2 Classification of chemically active substances: 3S2
16	Grid Specifications	IEC 61727, VDE 0126
17	Nominal Voltage & Frequency	415 Volts, 3-phase & 50 Hz
18	Grid Voltage Tolerance	\pm 15% and -10%
19	Communication protocol and interface	Modbus protocol over RS-485 interface

- 8.1.7. The inverters shall comply with applicable IEC/ equivalent BIS standard for environmental tests as per standard codes IEC 60068- 2 (1,2,14,30)/ Equivalent BIS Standard.

- 8.1.8. All inverters shall be IEC 61000 compliant for electromagnetic compatibility, harmonics, etc.
- 8.1.9. All inverters shall be safety rated as per IEC 62109 (1 &2), EN 50178 or equivalent DIN or UL standard.
- 8.1.10. All inverters shall be compliant with IEEE standard 929-200 or equivalent. The Contractor shall select the inverter as per its own system design so as to optimize the power output.
- 8.1.11. Display: The inverter shall have local LCD (Liquid crystal display) and keypad for monitoring instantaneous parameters, event logs and data logs. Display should be simple and self-explanatory, and should indicate:
- (a) Instantaneous DC power input
 - (b) DC input voltage
 - (c) DC Current
 - (d) Instantaneous active AC power output
 - (e) Instantaneous reactive AC power output
 - (f) AC voltage (all the 3 phases and line)
 - (g) AC current (all the 3 phases and line)
 - (h) kWh Produced during entire day
 - (i) Total kWh produced during its life time
 - (j) PCU must be provided with display
- 8.1.12. DC input terminals must be in enough numbers so as each terminal is connected to dedicated single input from the PV string. Two DC inputs cannot be connected to a single input DC terminal of the inverter. If adequate number of inputs are not available in the selected inverter by the Contractor then a DC junction box shall be incorporated into the design.
- 8.1.13. The inverter shall be tropicalized and design shall be compatible with conditions prevailing at site. Provision of exhaust fan with proper ducting for cooling of inverter's internal circuitry shall be incorporated in the inverter, keeping in mind the extreme climatic condition of the site.
- 8.1.14. The Contractor shall completely adhere to the installation guidelines of the inverter manufacturer including but not limited to protection from exposure to sun, rain and other weather condition.
- 8.1.15. Nuts and bolts and the PCU enclosure shall have to be adequately protected taking into consideration the atmosphere and weather prevailing in the area.
- 8.1.16. (Grid Connectivity) CERC/ RERC regulations and grid code as amended and revised from time to time shall be complied with.
- 8.1.17. All three phases shall be supervised with respect to rise/fall in programmable threshold values of frequency.
- 8.1.18. The inverter output shall always follow the grid in terms of voltage and frequency. This shall be achieved by sensing the grid voltage and phase and feeding this information to the feedback loop of the inverter. Thus, control variable then shall

control the output voltage and frequency of the inverter, so that inverter is always synchronized with the grid.

- 8.1.19. The inverter shall be capable of synchronizing with the grid in less than 1 (one) minute.
- 8.1.20. The inverter shall automatically “wake up” in the morning and begin to export power provided there is sufficient solar energy and the grid voltage and frequency is in range.
- 8.1.21. Sleep Mode: Automatic sleep mode shall be provided so that unnecessary losses are minimized at night. The power conditioner must also automatically re-enter standby mode when threshold of standby mode reached.
- 8.1.22. Stand-by Mode: The control system shall continuously monitor the output of the solar power plant until pre-set value is exceeded & that value to be indicated.
- 8.1.23. Basic System Operation (Full Auto Mode): The control system shall continuously monitor the output of the solar power plant until pre-set value is exceeded and that value to be indicated.
- 8.1.24. The inverter shall include appropriate self-protective and self-diagnostic features to protect itself and the PV array from damage in the event of inverter component failure or from parameters beyond the inverter’s safe operating range due to internal or external causes. The self-protective features shall not allow signals from the inverter front panel to cause the inverter to be operated in a manner which may be unsafe or damaging. Faults due to malfunctioning within the inverter, including commutation failure, shall be cleared by the inverter’s protective devices. In addition, the inverter shall have following minimum protection against various possible faults:
- (a) Ground fault monitoring
 - (b) Grid monitoring
 - (c) DC surge protection, Type II (if the inverter does not have integrated DC surge arrestors, then the surge arrestors shall be separately installed in the DC junction box on the positive and negative DC inputs)
 - (d) DC reverse polarity
 - (e) AC short-circuit capability
 - (f) Over-voltage and over-current
 - (g) Anti-islanding (as per IEEE 1547/UL 1741/ equivalent BIS standard)
 - (h) Balancing of unequal phases
 - (i) Negative earthing
 - (j) Manual DC isolator
- 8.1.25. Reactive Power: The output power factor of the inverter shall be of suitable range to supply or sink reactive power. The inverter shall have internal protection arrangement against any sustained fault in the feeder line and against lightning in the feeder line.
- 8.1.26. Inverter shall meet the reactive Power requirement of the induction motor pump set installed in Agriculture connections. Appropriate arrangements, if required, such as installing VFD mechanism can be considered for the same.

- 8.1.27. DC inputs of the inverters shall have suitably rated isolators on both positive and negative DC inputs to allow safe start up and shut down of the system. Circuit breakers used in the DC lines must be rated suitably.
- 8.1.28. No load loss < 1% of rated power and maximum loss in sleep mode shall be less than 0.05%.
- 8.1.29. The inverter shall have the facility of unit wise and integrated data logging.
- 8.1.30. The inverter shall be entirely self-managing and stable in operation. A self-diagnostic system check shall occur on start-up. Functions shall include a test of key parameters on start up.
- 8.1.31. The inverters shall be tested from the MNRE approved test centres/ NABL/BIS/IEC- accredited testing/ calibration laboratories.
- 8.1.32. Maximum power point tracker (MPPT) shall be integrated in the inverter to maximize energy drawn from the Solar PV array. The MPPT shall be microprocessor- based to minimize power losses. The MPPT unit shall conform to IEC 62093 for design qualification and efficiency of MPPT shall be greater than 99%.
- 8.1.33. Inverter shall be capable to convert the DC using its MPPT feature to produce AC power as per following:
- (a) The AC output voltage and frequency of the inverter must synchronize automatically to the exact AC voltage and frequency of the grid. Grid voltage shall be continuously monitored and in the event of voltage dip or rise above a pre-set value, the solar system shall be disconnected from the grid within the set time.
 - (b) In the case of inverters connected on different phases in the plant shall be capable of communicating with other and in the event of the fault even on a single phase all the inverters must be disconnected from the grid.
 - (c) Inverters shall have adjustable voltage setting and time settings. The output power factor shall be of suitable range to supply or sink reactive power.
- 8.1.34. The inverter shall have an RS-485 interface and support communication of its operational parameters and logs over Modbus protocol. The register mapping/ memory mapping of the inverter data shall be made available by the Contractor from the inverter supplier and the Contractor/ inverter supplier shall provide full support for integration of inverter's communication data with third- party software and hardware as directed by the Discom.
- 8.1.35. Discom or the TPIA reserves the right to inspect the inverters at the manufacturer's site prior to dispatch.

I.8 (a) SPV Controller

- 8(a).1. Maximum Power Point Tracker (MPPT) shall be included to optimally use the power available from the SPV array and maximize the water discharge.
- 8(a).2. The SPV Controller must have IP (65) protection or shall be housed in a cabinet having at least IP (65) protection.
- 8(a).3. Adequate protections shall be provided in the SPV Controller to protect the solar powered pump set against the following:

- a) Dry running;
- b) Open circuit;
- c) Accidental output short circuit;
- d) Under voltage;
- e) Reverse polarity;
- f) SPD to arrest high current surge; and
- g) Lightning arrestor.

8(a).4. A good reliable DC Circuit Breaker as per IS/IEC 60947-2 suitable for switching DC power ON and OFF shall be provided in the SPV Controller.

8(a).5. All cables used shall be as per IS 694. Suitable size of cable shall be used in sufficient length for inter-connection between the SPV array to SPV Controller and the SPV Controller to solar powered pump set. Selection of the cable shall be as per IS 14536.

8(a).6. Controller shall be integrated with GSM/GPRS Gateway with Geo tagging. GSM/GPRS Charges to be included in the Costing till the end of Warranty period of the Pump set.

I.9. Module Mounting Structure

9.1.1. Specification of module mounting structure shall be in line with specifications for SPV water pumping systems of MNRE vide Circular No. F. No. 41/3/2018-SPV Division dated 17.7.2019 enclosed as **Section L.3** and any further amendment(s) issued by MNRE.

9.1.2. Supply, installation, erection and acceptance of module mounting structure (MMS) with all necessary accessories, auxiliaries and spare part shall be in the scope of the Contractor.

9.1.3. Design of the MMS shall take into consideration site conditions, soil report, loading data, wind data and design standards as per latest applicable IS standard.

9.1.4. The structure shall be designed for simple mechanical and electrical installation. It shall support SPV modules at a given orientation and tilt, absorb and transfer the mechanical loads to the ground properly.

9.1.5. The Contractor shall be fully responsible for any damages caused by high wind velocity within guarantee period. The parameters of prevailing wind speed, soil conditions, load, and upward lift shall be taken care of while preparing the design and the same is required to be mentioned on design.

9.1.6. MMS shall be designed and positioned such that the PV modules are completely shadow-free solar during generation hours.

9.1.7. All solar panels shall be easily accessible for cleaning and the Agriculture Consumer shall not be inclined to climb on the MMS or PV modules for cleaning the PV modules.

9.1.8. Junction boxes shall be mounted on the MMS such that they are easily accessible and are protected from direct sunlight and harsh weather.

9.1.9. All the cables shall be aesthetically tied to module mounting structure.

- 9.1.10. Cutting, Welding, drilling etc. at site is not allowed for MMS. Contractor shall carry out all correction in structure (if required) at his works. If any cutting, welding, drilling is required to be done after material arrived at site then material shall be again sent for hot dip galvanization. No zinc spray shall be allowed on the MMS.
- 9.1.11. Contractor shall submit the all the quality test documents and test certificates complying with the requirement of the structure.
- 9.1.12. Contractor shall submit detailed drawings of the MMS and its civil foundations in line with MNRE specifications placed in Annexure L.3, results of design computations and stability calculations for foundations, and structural fitness of PV module mounting structures as per STADD Pro analysis.

I.10. DC Junction Box

- 10.1.1. The Contractor shall provide sufficient numbers of array junction boxes/ PV combiner boxes/ DC distribution boxes to comply with design requirements of the PV system.
- 10.1.2. All switch boards shall be provided with adequately rated bus-bar, incoming control, outgoing control etc. as a separate compartment inside the panel to meet the requirements of the Chief Electrical Inspector of Government (CEIG). All live terminals and bus bars shall be shrouded. The outgoing terminals shall be suitable to receive suitable runs and size of cables required for the inverter/ transformer rating.
- 10.1.3. The degree of protection for junction boxes shall be:
- (a) Indoor Junction box: IP 21(Minimum)
 - (b) Outdoor Junction Box: IP 65 (Minimum)
- 10.1.4. Junction boxes including the module junction box, string junction box, shall be equipped with appropriate functionality, safety (including fuses, grounding, etc.), and protection (surge, etc.) if not provided on the DC-side of the inverter.
- 10.1.5. The terminals shall be connected to bus bar arrangement of proper sizes to be provided. The junction boxes shall have suitable cable entry points fitted with cable glands of appropriate sizes for both incoming and outgoing cables. Suitable markings shall be provided on the bus bars for easy identification and cable ferrules will be fitted at the cable termination points for identification.
- 10.1.6. For array junction box/ PV combiner box, Contractor may also provide polyamide glands and MC4 Connectors. The rating of the junction box shall be suitable with adequate safety factor to interconnect the Solar PV array.
- 10.1.7. The junction boxes shall be dust, vermin, and waterproof and made of thermoplastic/ metallic in compliance with IEC 62208, which shall be sunlight/ UV- resistive as well as fire retardant and Protection Class II or higher.
- 10.1.8. The current carrying rating of the Junction Boxes shall be rated with standard safety factor to interconnect the Solar PV array.
- 10.1.9. Suitable markings shall be provided on the bus-bars for easy identification and cable ferrules will be fitted at the cable termination points for identification.
- 10.1.10. Detailed junction box specifications, certifications and data sheet shall be provided by the Contractor for approval during project execution.
- 10.1.11. Discom or the TPIA reserves the right to inspect the junction box at the manufacturer's site prior to dispatch.

10.1.12. It is recommended that the interim, the cables of 1000 Volts DC for outdoor installations shall comply with the draft EN 50618 for service life expectancy of 25 years.

I.11. AC Distribution Board

11.1.1. The inverter output shall have the necessary rated AC surge arrestors and MCB/MCCB. MCB shall be used for currents up to 63 Amperes, and MCCB shall be used for currents greater than 63 Amperes. RCCB shall be used by the Agency if required for successful operation of the PV system.

11.1.2. AC Distribution Board (ACDB) shall house all the equipment described above.

11.1.3. All switches and the circuit breakers, connectors shall conform to IEC 60947, part I, II and III/ IS60947 part I, II and III.

11.1.4. All the 415 VAC devices/ equipment like bus support insulators, circuit breakers, SPDs, VTs etc., mounted inside the switchgear shall be suitable for continuous operation and satisfactory performance under the following supply conditions:

(a) Variation in supply voltage: +/- 15 %

(b) Variation in supply frequency: +/- 3 Hz

I.12. Cables and Wires

12.1.1. All cables and connectors for use for installation of solar field must be of solar grade which can withstand harsh environment conditions for 25 years and voltages as per latest IEC standards. (Note: IEC standards for DC cables for PV systems is under development, the cables of 1000 volts DC for outdoor installations shall comply with the draft EN 50618 for service life expectancy of 25 years.)

12.1.2. Wires with sufficient ampacity and parameters shall be designed and used so that average voltage-drop at full power from the PV modules to inverter shall not be more than 2% (including diode voltage drop). PV Modules shall be connected with USE-2/ RHW-2 cables array to junction box conductors and junction box to photovoltaic disconnect with the sunlight resistant insulation cable. Due consideration shall be made for the de-rating of the cables with respect to the laying pattern in buried trenches/ on cable trays, while sizing the cables. The Contractor shall provide voltage drop calculations in excel sheet during the design approvals.

12.1.3. All cables shall be supplied in the single largest length to restrict the straight-through joints to the minimum number. Only terminal cable joints shall be accepted. No cable joint to join two cable ends shall be accepted. All wires used on the LT side shall conform to IS and shall be of appropriate voltage grade. Only copper conductor wires of reputed make shall be used for DC connections, while copper or aluminium conductor wires may be used for AC connections.

12.1.4. Insulation shall be LT PVC Type-C conforming to the requirements given in Table-I of IS: 5831/1984 with latest amendments. The thickness of inner sheath shall be as given in Table-4 of IS:1554(Pt.-I)/1988. The outer sheath shall consist of type ST-2 PVC Compound conforming to the requirements of IS:5831/1984. The thickness and tolerance on thickness of insulation shall be as per Clause No.9.2 of IS:1554(Pt.-I)/1988.

- 12.1.5. Cable routing/ marking: All cable/ wires are to be suitably tagged and marked with proper manner by good quality ferule or by other means so that the cable easily identified.
- 12.1.6. The cables shall be adequately insulated for the voltage required and shall be suitably colour coded for the required service. Bending radius for cables shall be as per manufacturer's recommendations and IS: 1255.
- 12.1.7. All the cables required for the installation provided by the Contractor. All cable schedules/ layout drawings shall be submitted by the Contractor for approval of the Discom or TPIA prior to installation.
- 12.1.8. Multi-strand, annealed high conductivity copper conductor PVC type 'A' pressure extruded insulation. Overall PVC insulation for UV protection Armoured cable shall be used for underground laying (if required). All cable trays including covers to be provided. All cables conform to latest edition of IEC/ equivalent BIS Standards as specified below: BoS item / component Standard Description Standard Number Cables General Test and Measuring Methods, PVC insulated cables for working Voltage up to and including 1100 V ,UV resistant for outdoor installation IS/IEC 69947.
- 12.1.9. Technical Specification of LT PVC Cables: General Constructional Features
- (a) The medium voltage cables shall be supplied, laid, connected, tested and commissioned in accordance with the drawings, specifications, relevant Indian Standards specifications, manufacturer's instructions. The cables shall be delivered at site in original drums with manufacturer's name, size, and type, clearly written on the drums.
 - (b) Material: The conductor shall be composed of plain aluminium or copper wires complying with IS:8130/1984 with latest amendments.
 - (c) Conductor: Uncoated, annealed aluminium, of high conductivity upto 4 mm² size, the conductor shall be solid and above 4 mm², conductors shall be concentrically stranded as per IEC: 228.
 - (d) Insulation: Insulation shall be LT PVC Type-C conforming to the requirements given in Table-I of IS: 5831/1984 with latest amendments.
 - (e) Core Identification:
 - Two core : Red and Black
 - Three core : Red, Yellow and Blue
 - Four core : Red, Yellow, Blue and Black
 - Single core : Green cable with Yellow strips for earthingBlack shall always be used for neutral. Solar DC cable shall be black with red strip for positive and black for negative in colour.
- 12.1.10. Armour: All cables laid underground shall be armoured. And laid in ground at a minimum depth of 0.5 meter. Armour shall be of galvanised steel flat strip/ round wires applied helically in single layers complete with covering the assembly of cores.
- (a) For cable size up to 25 Sq. mm. Armour of 1.4 mm dia G.I. round wire

(b) For cable size above 25 Sq. mm. Armour of 4 mm wide 0.8 mm thick G.I strip.

- 12.1.11. Sheath: The cable shall be rated extruded for PVC 90°C. Inner sheath shall be extruded type and shall be compatible with the insulation provided for the cables. Outer sheath shall be of an extruded type layer of suitable PVC material compatible with the specified ambient temp 50°C and operating temperature of cables. The sheath shall be resistant to water, ultraviolet radiation, fungus, termite and rodent attacks. The colour of outer sheath shall be black. Sequential length marking required at every 1.0 meter interval on outer sheath shall be available. The Contractor shall furnish resistance/ reactance/ capacitances of the cable in the technical datasheet. Packing and marking shall be as per Clause No. 18 of IS 7098 (part I)/1988 amended up to date.
- 12.1.12. Cable terminations shall be made with suitable cable lugs and sockets, crimped properly and passed through brass compression type cable glands at the entry and exit point of the cubicles.
- 12.1.13. All cable/wires shall be provided with Punched Aluminium tags only. The marking on tags shall be done with good quality letter and number ferrules of proper sizes so that the cables can be identified easily.
- 12.1.14. The wiring for modules interconnection shall be in the GI/ HDPE/DWC Pipe of reputed make.
- 12.1.15. The RS-485 cable from inverter to the metering box shall be armoured and may be laid along with the AC power cables only if there is no mutual interference. In case any interference is found between the power cables and the RS-485 cable, the RS-485 cable shall be separated by the contractor from AC power cable with a clearance of 300mm.

I.13. Lightning Protection for PV Array

- 13.1.1. All PV systems shall have lightning protection.
- 13.1.2. The source of over voltage can be lightning or other atmospheric disturbance. Main aim of over voltage protection is to reduce the over voltage to a tolerable level before it reaches the PV or other sub-system components as per IS: 2309 – 1989 (Reaffirmed-2005), Edition 3.1 (2006-01).
- 13.1.3. Necessary foundation/ anchoring for holding the lightning conductor in position to be made after giving due consideration to shadow on PV array, maximum wind speed and maintenance requirement at site in future.
- 13.1.4. The lightning conductor shall be earthed through flats and connected to the earth mats as per applicable Indian Standards with earth pits. Two earth pits shall be provided for each lightning arrestor. Each lightning conductor shall be fitted with individual earth pit as per required Standards including accessories, and providing masonry enclosure with cast iron cover plate having locking arrangement, watering pipe using charcoal or coke and salt as required as per provisions of IS & Earth Resistance of Lightning System must be less than one (1) Ohm.
- 13.1.5. If necessary more numbers of lightning conductors may be provided. The Contractor is also free to provide franklin rod/ early streamer type of lightning arrestors on the MMS structure designed in such a way not to cast shadow on the next raw of solar PV modules.

- 13.1.6. The Contractor shall submit the drawings and detailed specifications of the PV array lightning protection equipment to the Discom or TPIA for approval before installation of system.
- 13.1.7. Contractor shall provide dedicated earth pits for Lightning Arrestor as per relevant IS standard.

I.14. Power evacuation

- 14.1.1. Individual plant shall be connected to grid as per guidelines of CEA, RERC and Chief Electrical Inspector.
- 14.1.2. The output power from PV array would be fed to the inverters which converts DC produced by PV array to AC and feeds it into the main electricity grid after synchronization. In case of grid failure, or low or high voltage, solar PV system shall be out of synchronization and shall be disconnected from the grid.
- 14.1.3. Contractor shall follow the maximum capacity for interconnection with the grid at a specific voltage level shall be as specified in the Distribution Code/Supply Code of the State and amended from time to time.
- 14.1.4. Interconnection Voltage level: All solar plant interconnection voltage level shall be at LT 415VAC, 3-phase, 50 Hz.

I.15. Earthing

- 15.1.1. Each array structure of the PV yard, LT power system, earthing grid for switchyard, all electrical equipment, inverter, all junction boxes, etc. shall be grounded properly as per IS 3043-1987. All metal casing/ shielding of the plant shall be thoroughly grounded in accordance with Indian Electricity Act/ Rules.
- 15.1.2. Each string/ array and MMS of the plant shall be grounded properly. The array structures are to be connected to earth pits as per IS standards. Necessary provision shall be made for bolted isolating joints of each earthing pit for periodic checking of earth resistance.
- 15.1.3. The complete earthing system shall be mechanically and electrically connected to provide independent return to earth.
- 15.1.4. Earthing bus bar shall be terminated at both ends of the switchgear to suit the connections to outside earthing conductor. All components and the module are required to be earthed individually and are to be looped and connected to the earthing grid.
- 15.1.5. There will be three separate earthings viz. one for Lightning Arrestor, another for all mounting structure and third earthing for inverter and all electrical circuit.
- 15.1.6. Earthing system shall consist of earth grids and electrodes buried in soil in the plant area, embedded in concrete inside the buildings/rooms to which all the electrical equipment, metallic structures are connected to have earth continuity for safety reasons.
- 15.1.7. All the bolts of earthing system shall be of Stainless steel (SS) type.
- 15.1.8. Minimum earthing conductor size shall be 25 x 6 Sq. mm for aluminium strips.

- 15.1.9. The earthing system shall be designed with consideration of the earth resistivity of the project area. The earth resistivity values shall be measured prior to designing the earthing system. Unless otherwise specified, earthing system shall be in accordance with IS: 3043 and IEEE 80-2000, Indian Electricity Rules, Codes of practice and regulations existing in the location where the system is being installed.
- 15.1.10. The earthing shall be maintenance free Gel with Pipe in pipe/pipe in strip technology filled with anti corrosive conductive compound (CPRI Tested) below the ground in 150-200 mm dia.
- a) Gel earthing & Chemical compound should be type tested from Govt. approved / Govt. recognized / NABL Accredited laboratory / ILAC i.e. International Laboratory Accredited Laboratory (in case of foreign laboratory).
 - b) 50 mm dia GI pipe should be B class and strip of 25x6mm should be inserted top to bottom with no joint.
 - c) GI strip should be top to bottom inserted & welded on bottom part of electrode.
 - d) GI strip should be hot dip galvanized as per IS-3043 standard 80-100 micron zinc coating.
 - e) CCM (crystalline conductive mixture) should be anticorrosive & to be filled top to bottom in electrode.
 - f) Chemical compound PH value should not be less than 8.
 - g) With 3/6 mtr electrode 2 bags (25kg each)/4 bags chemical compound has to be filled in bore.
 - h) For semi rocky & rocky area 8 bags (25 kg each) chemical compound has to be filled in open bore.
 - i) Chemical compound has to mixed with water to make it in paste form and pour surrounding area of electrode.
 - j) For 50mm dia electrode bore size should be 6 inch x 3.5/6.5 mtr depth.
 - k) Earth resistance for single earth should be less than 2 ohms
 - l) All body connections should be connected with gi earthing
 - m) Supply & Erection of Maintenance free Gel earthing with strip in pipe technology filled with anti corrosive conductive compound (CPRI Tested) below the ground in 150-200 mm dia. Earth pit & surrounding filled with required mineral filling compound (MFC should have hygroscopic property to retain the moisture for long time to create low resistance zone) and C.C. finished chamber covered with hinged type with locking arrangement C.I. Cover, C.I. Frame of size 300mm X 300mm complete testing of earth resistance as required G.I Pipe (IS : 1239 marks) GI pipe 3000/6000 mm long, 50 mm Dia, GI/Cu Strip. Earthing as per IS:3043-1987 and its latest amendments.

I.16. Low voltage (LV) Switchgears

- 16.1.1. LV switchboard shall be IP 21 for indoor and IP 65 for outdoor application made with heavy duty PVC/ metal enclosure.
- 16.1.2. LV switchboard with metal enclosure shall be minimum 2mm thick and with properly coated.

- 16.1.3. MCB/MCCB/ RCCB and cables shall be rated as per rated current of the circuit, application voltage class, short circuit capacity.
- 16.1.4. All switchboards shall be supplied completely wired internally upto the terminals, ready to receive external cables.
- 16.1.5. No extra holes shall be allowed in the gland plate. Proper vermin proofing of the panel is required.
- 16.1.6. Suitable cable entry shall be provided considering bending radius of the incoming and outgoing cable.
- 16.1.7. All cables, MCB, MCCB, RCCB shall be of reputed make.

I.17. Solar Meter

- 17.1.1. Uni-directional Smart Energy Meters to log the actual value of Energy generated by the PV system be provided, as per relevant specifications by MNRE/ CEA/Discom. Detailed indicative specifications shall be shared with successful bidder.

I.18. Net-Meter

- I.19. The bi-directional Smart energy meter shall be installed for the measurement of import/Export of energy, as per relevant specifications by MNRE/ CEA/Discom. Detailed indicative specifications shall be shared with successful bidder.
 - 19.1.1. Old meter of the existing Agriculture consumer shall be replaced by the Contractor after issue of Meter Change Order by concerned AEN (O&M) of Discom on the same day of installation of net-meter. The old meter is to be deposited by the Contractor in the concerned Office of AEN (O&M) of Discom.
 - 19.1.2. Net-meter shall be installed in the presence of the Contractor, the Agriculture Consumer, concerned AEN (O&M), AEN (M&P) and Nodal Officer jointly with preparation of “Joint Inspection Report” (JIR) in prescribed format.

I.20. Civil Work

- 20.1.1. Specification of civil work shall be in line with specifications for SPV water pumping systems of MNRE vide Circular No. F. No. 41/3/2018-SPV Division dated 17.7.2019 enclosed as **Section L.3** and any further amendment(s) issued by MNRE.
- 20.1.2. The scope works shall cover for all services required for completion of civil works in all respect for PV plant. All machineries, tools and designs to be arranged by Contractor.
- 20.1.3. Contractor shall carry out geotechnical survey prior to design and installation of the PV system.
- 20.1.4. The work shall be executed according to the specifications and good standard practice necessary to fulfil the objective of the survey work, strictly in accordance with the instructions and satisfaction of the Discom.
- 20.1.5. Foundations:
 - (a) The Contractor is responsible for the detailed soil investigation and subsequent foundation design of the structures in the plant. Minimum 5 (five) numbers of soil exploration is to be carried out for each feeder. The foundation of the module mounting structures foundation and other important equipment foundation must be approved through Discom or TPIA prior to

construction. The Contractor shall provide the detailed design report with calculations of the proposed foundation. Pedestals over the MMS foundation shall be projected minimum 150 mm above the finished ground level.

- (b) The foundations shall be designed considering the weight and distribution of the load of structure and its assembly. The foundation shall be design in accordance to recommendation and results of soil investigation reports and mounting structure shall be designed for maximum wind speed as per the wind zone of the location and relevant IS. Seismic effect relevant to the seismic zone of the area and highest water logging level has to be considered while making the design of the foundation.
- (c) The MMS foundation shall be constructed using RCC concrete pile foundation of required diameter and depth based on approved design.
- (d) The elevated structure has to be securely anchored to the supporting surface, also bolted with anchor bolts of appropriate strength for elevated structures mounted on RCC surfaces.

I.21. Caution Signs

21.1.1. In addition to the standard caution and danger boards or labels as per Indian Electricity Rules, the AC distribution box near the solar grid inverter and the distribution board to which the AC output of the solar PV system is connected shall be provided with a noncorrosive caution label with the following text:

WARNING – DUAL POWER SOURCE
SECOND SOURCE IS SOLAR SYSTEM

21.1.2. The size of the caution label shall be 105mm (width) x 20mm (height) with white letters on a red background.

I.22. Sign Boards

22.1.1. The sign board containing brief description of various components of the power plant as well as the complete power plant in general shall be installed at appropriate location near the PV system.

22.1.2. The Signboard shall be made of MS angle or pipe for vertical post with ACP (Aluminium Composite Panel) sheet of not less than 3 mm. The Contractor shall provide detailed specifications of the sign boards as per requirement of the Discom.

22.1.3. Name Plate: Name Plate in Hindi language of size 600 mm x 600 mm x 2 mm on iron plate is required to be prepared as provided in SECTION - K: (Format K.5) separately and required to be fixed on the system for every installation.

I.23. Drawings & Manuals

23.1.1. Two sets of engineering, electrical drawings and Installation and O&M manuals are to be supplied. Bidder shall provide complete technical data sheets for each equipment giving details of the specifications along with make/makes in their bid along with basic design of the PV Installation setup and power evacuation, synchronization along with protection equipment.

23.1.2. The Contractor shall furnish the following drawings (in line with MNRE specifications placed in Annexure L.3) after Letter of Award/ Letter of Intent and obtain approval:

- (a) General arrangement and dimensioned layout.
- (b) Schematic drawing showing the requirement of PV panel, Power conditioning Unit(s)/ inverter, Junction Boxes, AC and DC Distribution Boards, meters etc.
- (c) Routing diagram of cables and wires.
- (d) Data sheets and user manuals of the solar PV panels and the solar grid inverter.
- (e) Structural drawing along with foundation details for the structure.
- (f) Itemized bill of material for complete SV plant covering all the components and associated accessories.
- (g) Layout of solar Power Array
- (h) Shadow analysis of the site
- (i) Maintenance register.

23.1.3. Approved ISI and reputed makes for equipment be used.

23.1.4. For complete electromechanical works, Contractor shall supply complete design, details and drawings for approval to Discom and TPIA before progressing with the installation work.

I.24. Planning & Designing

24.1.1. The Discom reserves the right to modify the layout and specification of sub- systems and components at any stage as per local site conditions/requirements.

24.1.2. The Contractor shall submit preliminary drawing for approval and based on any modification or recommendation, if any. The Contractor shall submit three sets and soft copy in CD of final drawing for formal approval to proceed with construction work.

I.25. Safety Measures

25.1.1. The Contractor shall take entire responsibility for electrical safety of the installation(s) including connectivity with the grid and follow all the safety rules & regulations applicable as per Electricity Act, 2003 and CEA guidelines, as well as applicable rules & regulations of Rajasthan State, etc.

I.26. Maintenance & Generation Guarantee

26.1.1. Comprehensive Maintenance (CMC)

- a) The Contractor shall undertake comprehensive maintenance of the PV system including all its equipment and subsystems for a period of 5 (five) years from the date of commissioning of the last system of total awarded work or, 9 month from the date of award of work (LoA), whichever is later.
- b) This shall also include free replacement warranty on spare parts against manufacturing defects for five years from the date installation.
- c) The Contractor shall attend to any complaint from the Agriculture Consumer and rectify any faults or breakdown within a timeframe of 72 (seventy two) hours from such complaint. In case of theft, the complaint is to be resolved within 15 calendar days provided theft is duly certified by the nodal officer.

- d) If the down time period for any beneficiary complaint exceeds 72 hours (15 calendar days in case for theft cases) and the contractor fails to make the plant operational, a penalty for the time period exceeding 72 hours (15 calendar days in case for theft cases), as per the below mentioned schedule shall be deposited by the contractor to the concerned AO of circle / as decided by DISCOM.

Water pump capacity (in HP)	Penalty applicable (in INR per day)
3	140
5	235
7.5	355

- e) The loss in generation shall be decided on daily basis.
- f) For any system / consumer complaint, the maximum applicable amount as penalty against loss of generation shall not be more than 10% of the respective cost of the SPV system installed at the consumer premises.
- g) The Contractor shall be issued a notice to pay the applicable penalty within 7 days to the concerned AO of circle / as decided by DISCOM. If the Contractor fails to pay the penalty within notice period, the Discom shall encash the Performance Security immediately.
- h) CMC will include submission of monthly /quarterly inspection report of the installation as per prescribed format of Discom. As per the SECTION - K: (Format K.13) quarterly report shall be prepared and submitted to DISCOM after providing necessary services.
- i) To ensure timely maintenance of the systems the vendor shall have one Office-cum-service centre in each operational district and a helpline in local language in each operational State.
- j) Rajasthan Discom gives great importance to maintenance of the systems & it is felt that without proper maintenance after installation of system, consumers may be deprived of the benefits of this Scheme. To achieve this objective, Contractor shall proceed to first establish office-cum-service centre in each operational district for installation of systems. Contractor shall be bound to provide after sales service to the beneficiaries in the vicinity of the area of the installed systems or at least at tehsil level /at district to facilitate CMC services. The beneficiaries shall be well informed about the CMC centre of the Contractor, call centre/toll free numbers. This may consist of office cum service centre at a convenient place to be reached by a beneficiary. Such office cum service centres shall have spares for the system and repair facility. The Concerned Nodal officer of Discom shall verify this fact and only then Contractor shall be allowed to install the systems.
- k) The Contractor will educate the Beneficiaries on the process for registering the complaints on Call Center/toll free nos. The details of office cum after sales service centers along with telephone numbers & contact persons of firm & details of Discom offices, address and telephone numbers must be provided to each beneficiary. Beneficiaries shall also be educated through brochures about dos & don'ts on the system. Contractor will update the status of fault rectification on Discom website /call centre for online monitoring of the complaints registered and services being provided by the Contractor.
- l) It may be carefully noted that maintenance of SPV Systems includes maintenance of all items including all accessories.

26.1.2. Generation Guarantee

- a) The Contractor shall provide a minimum generation guarantee corresponding to a capacity utilization factor (CUF) of 15% (the “Guaranteed CUF”) with respect to the AC capacity of the PV system.
- b) This Guaranteed CUF shall be calculated on an annual-basis and shall be verified by the Discom at the end of each year during the 5 (five) year guarantee period.
- c) There shall be no year-on-year reduction on the Guaranteed CUF during the 5 (five) year guarantee period.
- d) In case of energy generation corresponding to the average of surrounding 10 such locations is less or less than the Guaranteed CUF, whichever is higher, the Discom shall recover an amount at the rate of Rs. 7.00 per kWh from the Contractor for such shortfall at the end of the contract year to compensate the same to the Agriculture Consumer.
- e) In case of theft (duly certified by the nodal officer) or, non-availability of grid due to fault in feeder, the DISCOM reserves the right to consider appropriate adjustment in CUF for the corresponding period.
- f) In case of energy generation corresponding to less than the Guaranteed CUF, it is clarified that the penalty for loss in generation shall not be duplicated with the penalty for delay in rectification of fault beyond 72 hours of complaint.

I.27. Project Management

27.1.1. Testing and Third-Party Inspection

- a) The Contractor shall provide all relevant plant and equipment specifications, data sheets, certificates, designs, drawings, etc. to the Discom and TPIA for approval prior to commencement of installation. Structural designs shall be provided to the TPIA in STAAD Pro format for verification and approval.
- b) The Discom and the TPIA shall have, at all times, access to the Contractor’s premises and also shall have the power to inspect and examine the materials and workmanship of project work during its manufacturing, shop assembly and testing. If part of the equipment is required to be manufactured in the premises other than the Contractor’s, the necessary permission for inspection shall be obtained by the Contractor on behalf of the Discom and the TPIA.
- c) The Discom and the TPIA shall have the right to serve notice in writing to the Contractor on any grounds of objections, which they may have in respect of the work. The Contractor shall have to satisfy the objection, otherwise, the Discom at its liberty may reject any or all components of equipment or workmanship connected with such work.
- d) The Contractor shall issue request letter to Discom for testing of any component of the plant, which is ready for testing at least 15 (fifteen) days in advance from the date of actual date of testing at the premises of the Contractor or elsewhere. When the inspection and the tests have been satisfactorily completed at the Contractor’s works, Discom or the TPIA shall issue a certificate to that effect. However, Discom at its own discretion may waive the inspection and testing in writing. In such case, the Contractor may proceed with the tests which shall be deemed to have been made in the Discom or the TPIA’s presence, and it shall forthwith forward 6 (Six) sets of duly certified copies of test results and certificates to the Discom and the TPIA for

approval of Discom. The Contractor, on receipt of written acceptance from Discom or the TPIA, may dispatch the equipment for erection and installation.

- e) For all tests to be carried out, whether in the premises of the Contractor or any subcontractor or the supplier, the Contractor shall provide labour, materials, electricity, fuel, water, stores, apparatus and instruments etc. free of charge as may reasonably be demanded to carry out such tests of the equipment. The Contractor shall provide all facilities to Discom and the TPIA to accomplish such testing.
- f) The Discom or the TPIA shall have the right to carry out inward inspection of the items on delivery at the Site and if the items have been found to be not in line with the approved specifications, shall have the liberty to reject the same.
- g) Neither the waiving of inspection nor acceptance after inspection by the Discom or the TPIA shall, in anyway, absolve the Contractor of the responsibility of supplying the equipment strictly in accordance with requisite standards and specifications.
- h) Discom and/ or the TPIA shall undertake final commissioning test of the PV system including its design, specification, safety and performance.

I.28. Other Key Responsibilities

28.1.1. MNRE/ Discom Inspection & Reporting

- a) The Ministry officials or designated agency may inspect the ongoing installation or installed plants. In case the installed systems are not as per standards, non-functional on account of poor quality of installation, or non-compliance of AMC, the Ministry reserves the right to blacklist the Contractor. Blacklisting may inter-alia include the following:
 - (a) The Contractor will not be eligible to participate in tenders for Government supported projects.
 - (b) In case, the concerned Director(s) of the Contractor joins another existing or starts/ joins a new firm/company, the company will automatically be blacklisted.
- b) The Contractor shall be responsible for providing daily / weekly / monthly or customized information regarding progress of projects required by Discom / MNRE, online or in hard copy. For which the Contractor is also responsible for maintaining online & off-line records.
- c) Assist Discom with a real-time monitoring dedicated web-portal.
- d) Providing training to the locals.

28.1.2. Net-Metering of Power

- a) Net metering is the concept which records difference between export of generated energy and import of energy from Discom grid during billing cycle.
- b) Rajasthan Electricity Regulatory Commission (RERC) has issued “Regulation for net metering and grid connectivity” on 26th February, 2015. The Agriculture Consumers / Contractor going for installation of SPV Power units under this scheme will also be governed by the rules & regulations of Net Metering scheme as notified by RERC and amended time to time.
- c) The Contractor shall bear the entire cost of metering arrangement (including meter testing fee) and its accessories. The fee and other charges, if applicable, such as

security deposit payable to office of Discom & Electrical inspector will be payable by the beneficiary separately prior to the system installation.

- d) The installation of meters including CTs & PTs, wherever applicable, shall be carried out by the supplier as per the procedures in line with Discom(s) guidelines and with their permission.

SECTION - J: BID SUBMISSION FORMATS

J.1. Bid Security

{To be executed on Non-judicial Stamp paper of worth 0.25% of Bank Guarantee Value (maximum stamp duty of Rs25000/-) If the BG is furnished from bank of other state with different Stamp Worth, then the difference value will be submitted on Rajasthan NJS Paper}

Bid Security

Bank Guarantee No.:

Date:

To

Superintending Engineer (Regulation)

Room No. 149, Old Power House Premises,

Banipark, Jaipur-302016

WHEREAS M/s. (insert name of Bidder)..... having its Registered/Head Office at (insert address of the Bidder) (Hereinafter called "the Bidder") has submitted its Bid for the performance of the Contract for the work of design, survey, supply, installation, testing, commissioning & 5 years comprehensive maintenance of distributed grid connected solar PV systems for solarization of grid connected agriculture consumers under "KUSUM Scheme – Component C" in Jaipur Discom under NIT No: JVVNL/KUSUM-C/GRID-SPV/TN-04/2020 (Lot 1 to 10) (Hereinafter called "the Bid")

KNOW ALL PERSONS by these present that WE (*Insert name & address of the issuing bank*) having its Registered/Head Office at (*Insert address of registered office of the bank*)..... (Hereinafter called "the Bank"), are bound unto Jaipur Vidyut Vitran Nigam Limited (hereinafter called "the Employer") in the sum of..... (*Insert amount of Bid Security in figures & words*)..... for which payment well and truly to be made to the said Employer, the Bank binds itself, its successors and assigns by these presents.

Sealed with the Common Seal of the said Bank this day of 20....

The "Conditions" of this obligation are:

1. If the Bidder withdraws its bid during the period of bid validity specified in the "Tender Document" issued vide NIT No: JVVNL/KUSUM-C/GRID-SPV/TN-04/2020 (Lot 1 to 10); or

2. In case the Bidder does not withdraw the deviations proposed by him, if any, at the cost of withdrawal stated by him in the bid and/or accept the withdrawals/rectifications pursuant to the declaration/confirmation made by him in Format – Declaration on Deviation in the Bid; or
3. If the Bidder does not accept the corrections to arithmetical errors identified during preliminary evaluation of his bid pursuant to SECTION - F:(13.1.4) of Tender Document; or
4. In the case of a successful Bidder, if the Bidder fails within the specified time limit
 - a. to sign the Contract Agreement, in accordance with SECTION - G:(G.4) of Tender Document; or
 - b. to furnish the required Performance Security, in accordance with SECTION - G:(G.2) of Tender Document; or
5. In any other case, specifically provided for in Tender Document.
6. All disputes arising under this said Guarantee between the Bank and the Employer or between the Contractor and the Employer pertaining to this said Guarantee shall be subject to the jurisdiction of Courts only at Jaipur, Rajasthan alone.

We undertake to pay to the Employer up to the above amount upon receipt of its first written demand, without the Employer having to substantiate its demand, provided that in its demand the Employer will note that the amount claimed by it is due to it, owing to the occurrence of any of the above-named Conditions or their combination, and specifying the occurred Condition or Conditions.

This guarantee will remain in full force up to and including (Valid for 30 days beyond the Bid Validity i.e. 6 months + (plus) additional 30 days grace period)..... and any demand in respect thereof must reach the Bank not later than the above date.

For and on behalf of the Bank

[Signature of the authorised signatory (ies)]

Signature_____

Name_____

Designation_____

POA Number_____

Contact Number(s): Tel._____ Mobile_____

Fax Number_____

email _____

Common Seal of the Bank_____

Witness:

Signature_____

Name_____

Address_____

Contact Number(s): Tel._____ Mobile_____

email _____

Note:

- 1. In case the bid is submitted by a Joint Venture, the Bid Security of a JV must be in the name of all the partners, lead or other partner in the joint venture submitting the bid.**
2. The Bank Guarantee shall be in accordance with the proforma as provided. However, in case the issuing bank insists for additional paragraph for limitation of liability, the following may be added at the end of the proforma of the Bank Guarantee [*i.e., end paragraph of the Bank Guarantee preceding the signature(s) of the issuing authority(ies) of the Bank Guarantee*]:

Quote

“Notwithstanding anything contained herein:

- 1. Our liability under this Bank Guarantee shall not exceed _____ (value in figures)_____ [_____ (value in words)_____].*
- 2. This Bank Guarantee shall be valid upto _____(validity date)_____.*
- 3. We are liable to pay the guaranteed amount or any part thereof under this Bank Guarantee only & only if we receive a written claim or demand on or before _____ (validity date) _____.”*

Unquote

J.2. Format of Affidavit for MSME Unit

{On Non-Judicial Stamp Paper of Rs. 100/- attested by Notary Public/ First Class Magistrate}

Affidavit for MSME Unit

IS/oAge Yrs. Residing at
..... Proprietor/Partner/ Director of M/s
("Enterprise") do hereby solemnly affirm and declare that:

- (a) My/Our above noted Enterprise M/s has been issued acknowledgement of Entrepreneurial Memorandum Part - II by the District Industries Centre The acknowledgement No. is dated and has been issued for manufacture of following items:

S. No.	Name of Item	Production Capacity (Yearly)
1		
2		
3		
4		
5		

- (b) My/Our above noted acknowledgement of Entrepreneurial Memorandum Part - II has not been cancelled or withdrawn by the Industries Department and that the Enterprise is regularly manufacturing the above items.
- (c) My/Our Enterprise is having all the requisite plant and machinery and is fully equipped to manufacture the above noted items.
- (d) The present status of the firm is as per acknowledgment of Entrepreneurial Memorandum Part-II issued on the date of District Industries Centre.

Place

Signature of Proprietor/ Director/
Authorized Signatory with Stamp and Date

VERIFICATION

I, _____ S/o _____ Aged____ Years
residing at _____ Proprietor/ Partner/ Director of
Enterprise M/s _____ verify and confirm
that the contents at (a), (b), (c) & (d) above are true and correct to the best of my knowledge
and nothing has been concealed therein. So, help me God.

DEPONENT

J.3. Power of Attorney in favour of Authorized Signatory (In Case of Bidder is Single Entity)

{On Non-Judicial Stamp Paper of Rs. 500/- attested by Notary Public/ First Class Magistrate}

The Bidder is required to submit the Power of Attorney in the Format as per the applicable Law.

J.4. Power of Attorney in favour of Authorized Signatory (In Case Bidder is Joint Venture)

{On Non-Judicial Stamp Paper of Rs. 500/- attested by Notary Public/ First Class Magistrate}

Power of Attorney in favour of Authorized Signatory

KNOW ALL MEN BY THESE PRESENTS THAT WE, the Partners whose details are given hereunder have formed a Joint Venture under the laws of and having our Registered Office(s)/Head Office(s) at (hereinafter called the 'Joint Venture' which expression shall unless repugnant to the context or meaning thereof, include its successors, administrators and assigns) acting through M/s being the Partner in-charge do hereby constitute, nominate and appoint M/s..... a Company incorporated under the laws of and having its Registered/Head Office at as our duly constituted lawful Attorney (hereinafter called "Attorney" or "Authorised Representative" or "Partner In-charge") to exercise all or any of the powers for and on behalf of the Joint Venture in regard to "Bid Specification" for the work of design, survey, supply, installation, testing, commissioning & 5 years comprehensive maintenance of distributed grid connected solar PV systems for solarization of grid connected agriculture consumers under "KUSUM Scheme – Component C" in Jaipur Discom, under NIT No: JVVNL/KUSUM-C/GRID-SPV/TN-04/2020 (Lot 1 to 10), for which bids have been invited by Jaipur Vidyut Vitran Nigam Limited ("JVVNL" / "Jaipur Discom") undertake the following acts:

- i. To submit proposal and participate in the aforesaid Bid Specification of JVVNL on behalf of the "Joint Venture".
- ii. To negotiate with Discom the terms and conditions for award of the Contract pursuant to the aforesaid Bid and to sign the Contract with the Discom for and on behalf of the "Joint Venture".
- iii. To do any other act or submit any document related to the above.
- iv. To receive, accept and execute the Contract for and on behalf of the "Joint Venture".

It is clearly understood that the Partner In-charge (Lead Partner) shall ensure performance of the Contract(s) and if one or more Partner fail to perform their respective portions of the Contract(s), the same shall be deemed to be a default by all the Partners.

It is expressly understood that this Power of Attorney shall remain valid binding and irrevocable till completion of the period to complete all the Scope of Work awarded under the terms of Bid Specification/ Contract.

The Joint Venture hereby agrees and undertakes to ratify and confirm all the whatsoever the said Attorney/Authorised Representatives/Partner in-charge quotes in the bid and negotiates with JVVNL and signs the Contract with Discom and/or

proposes to act on behalf of the Joint Venture by virtue of this Power of Attorney and the same shall bind the Joint Venture as if done by itself.

IN WITNESS THEREOF the Partners Constituting the Joint Venture as aforesaid have executed these presents on this day of under the Common Seal(s) of their Companies.

For and on behalf of the
Partners of Joint Venture

.....
.....
.....

The Common Seal of the above Partners of the Joint Venture:

The Common Seal has been affixed there unto in the presence of:

WITNESS

1. Signature.....
 Name
 Designation
 Occupation

2. Signature.....
 Name
 Designation
 Occupation

Note:

1. For the purpose of executing the Agreement, the non-judicial stamp papers of appropriate value shall be purchased in the name of Joint Venture.

2. The Agreement shall be signed on all the pages by the authorised representatives of each of the partners and shall invariably be witnessed.

J.5. Undertaking by the Joint Venture Partners (In Case Bidder is Joint Venture)

{On Non-Judicial Stamp Paper of Rs. 500/- attested by Notary Public/ First Class Magistrate}

Undertaking by Joint Venture

THIS JOINT DEED OF UNDERTAKING executed on this..... day of..... Two Thousand and..... by a company incorporated under the laws of and having its Registered Office at(hereinafter called the "Party No.1" which expression shall include its successors, executors and permitted assigns) and M/s.....a company incorporated under the laws of and having its Registered Office at (hereinafter called the "Party No.2" which expression shall include its successors, executors and permitted assigns) for the purpose of making a bid and entering into a contract [hereinafter called the "Contract" {in case of award}] against the “Bid Specification” for the work of design, survey, supply, installation, testing, commissioning & 5 years comprehensive maintenance of distributed grid connected solar PV systems for solarization of grid connected agriculture consumers under “KUSUM Scheme – Component C” in Jaipur Discoms under NIT No: JVVNL/KUSUM-C/GRID-SPV/TN-04/2020 (Lot 1 to 10), the bids for which have been invited by Jaipur Vidyut Vitran Nigam Limited (“JVVNL” / “Jaipur Discom”)

WHEREAS the Party No.1 and Party No.2 have entered into an Agreement dated.....

AND WHEREAS JVVNL has invited bids as per the above mentioned Bid Specification for the work of design, survey, supply, installation, testing, commissioning & 5 years comprehensive maintenance of distributed grid connected solar PV systems for solarization of grid connected agriculture consumers under “KUSUM Scheme – Component C” in Jaipur Discom, under NIT No: JVVNL/KUSUM-C/GRID-SPV/TN-04/2020 (Lot 1 to 10), details stipulated in the Tender Document issued vide: NIT No: JVVNL/KUSUM-C/GRID-SPV/TN-04/2020 (Lot 1 to 10).

AND WHEREAS SECTION - D:(1.1.1) forming part of the Tender Document, inter-alia stipulates that an Undertaking of two or more qualified entities as partners in a Joint Venture, meeting the requirements of Eligibility & Qualification Criteria SECTION - D:, as applicable may bid, provided, the Joint Venture fulfills all other requirements under SECTION - D: and in such a case, the Bid Formats shall be signed wherever applicable and as required by Tender Document either by the Authorized Signatory (appointed by a Power of Attorney executed by all partners of Joint Venture) and/or all the partners so as to legally bind all the Partners of the Joint Venture, who will be jointly and severally liable to perform the Contract and all obligations hereunder.

The above clause further states that this Undertaking shall be attached to the bid and the Performance Security will be as per the format enclosed with the Tender Document without any restrictions or liability for either party.

AND WHEREAS the bid is being submitted to JVVNL vide Bid No.....(Reference No: of Bid submitted by Bidder) dated by Party No.1 based on this Undertaking between all the parties; under these presents and the bid in accordance with the requirements of Tender Document, has been signed by all the parties.

NOW THIS UNDERTAKING WITNESSETH AS UNDER:

In consideration of the above premises and agreements all the parties of this Deed of Undertaking do hereby declare and undertake:

1. In requirement of the award of the Contract by JVVNL to the Joint Venture Partners, we, the Parties do hereby undertake that M/s..... the **Party No.1**, shall act as Lead Partner and further declare and confirm that we the parties to the Joint Venture shall jointly and severally be bound unto Discom for the successful performance of the Contract and shall be fully responsible for successful completion and performance of Scope of Work as provided in Contract in accordance with the terms and conditions specified in the Contract.
2. In case of any breach or default of the said Contract by any of the parties to the Joint Venture, the party(s) do hereby undertake to be fully responsible for the successful performance of the Contract and to carry out all the obligations and responsibilities under the Contract in accordance with the requirements of the Contract.
3. Further, if the Discom suffers any loss or damage on account of any breach in the Contract or any shortfall in the performance of the equipment in meeting the performances guaranteed as per the specification in terms of the Contract, the Party(s) of these presents undertake to promptly make good such loss or damages caused to the Discom, on its demand without any demur. It shall not be necessary or obligatory for the Discom to proceed against Lead Partner to these presents before proceeding against or dealing with the other Party(s), the Discom can proceed against any of the parties who shall be jointly and severally liable for the performance and all other liabilities/obligations under the Contract to the Discom.
4. The financial liability of the Parties of this Deed of Undertaking to the JVVNL, as applicable, with respect to any of the claims arising out of the performance or non-performance of the obligations set forth in this Deed of Undertaking, read in conjunction with the relevant conditions of the Contract shall, however not be limited in any way so as to restrict or limit the liabilities or obligations of any of the Parties of this Deed of Undertaking.
5. It is expressly understood and agreed between the Parties to this Undertaking that the responsibilities and obligations of each of the Parties shall be as delineated in Appendix – *(to be suitably appended by the JV Partners alongwith this Undertaking in its bid)* to this Deed of Undertaking. It is further undertaken by the

parties that the above sharing of responsibilities and obligations shall not in any way be a limitation of joint and several responsibilities of the Parties under the Contract.

6. It is also understood that this Undertaking is provided for the purposes of undertaking joint and several liabilities of the partners to the Joint Venture for submission of the bid and performance of the Contract and that this Undertaking shall not be deemed to give rise to any additional liabilities or obligations, in any manner or any law, on any of the Parties to this Undertaking or on the Joint Venture, other than the express provisions of the Contract.
7. This Undertaking shall be construed and interpreted in accordance with the provisions of the Contract.
8. In case of an award of a Contract, we the parties to this Deed of Undertaking do hereby agree that we shall be jointly and severally responsible for furnishing a Contract Performance Security from a bank in favour of Discom in the currency/currencies of the Contract.
9. It is further agreed that this Deed of Undertaking shall be irrevocable and shall form an integral part of the bid and shall continue to be enforceable till the Discom discharges the same or upon the completion of the Contract in accordance with its provisions, whichever is earlier. It shall be effective from the date first mentioned above for all purposes and intents.

IN WITNESS WHEREOF, the Parties to this Deed of Undertaking have through their authorised representatives executed these presents and affixed Common Seals of their companies, on the day, month and year first mentioned above.

Common Seal of
has been affixed in my/ our
presence pursuant to Board of
Director's Resolution dated

For Lead Partner (Party No.-1)
For and on behalf of M/s
.....

Name
Designation

Signature

(Signature of the authorized
representative)

WITNESS :

I.
II.

Common Seal of

For Party No.-2

Revised Tender document for solarization of grid connected agriculture consumers

has been affixed in my/ our
presence pursuant to Board of
Director's Resolution dated

For and on behalf of
M/s.....

Name

(Signature of the authorized
representative)

Designation

Signature

WITNESS :

I.

II.

Note:

1. For the purpose of executing the Joint Deed of Undertaking, the non-judicial stamp papers of appropriate value shall be purchased in the name of Joint Venture.
2. The Undertaking shall be signed on all the pages by the authorised representatives of each of the partners and shall invariably be witnessed.
3. Attach the Appendix.....as mentioned in the Clause 5 of this Deed of Undertaking.

J.6. Bid Submission Letter/Undertaking

(On Letterhead of Bidder/ Lead Member of JV)

Bid Submission Letter

In Response to NIT No:	JVVNL/KUSUM-C/GRID-SPV/TN- 04/2020 (Lot 1 to 7)
------------------------	-------------------------------------------------

From:- (Full name of Bidder / Lead Member of JV)

Address of the Organisation.....

Name of Authorized Signatory:.....

Designation:.....

Email ID:.....

PHONE /MOBILE NO.:.....

To

Superintending Engineer (Regulation)

Room No. 149, Old Power House Premises,

Banipark, Jaipur-302016

Sub: Bid for Tender for Work of Design, survey, supply, installation, testing, commissioning & 5 years comprehensive maintenance of distributed grid connected solar PV systems for solarization of grid connected agriculture consumers under “KUSUM Scheme – Component C” in Jaipur Discom under TN-04/2020 (Lot 1 to 10).

Ref: NIT NO: JVVNL/KUSUM-C/GRID-SPV/TN-04/2020 (Lot 1 to 10) dated;

Dear Sir,

In connection with the above subject, I / We confirm the following:

1. I/We, the undersigned.....[insert name of the ‘Bidder’] having read, examined and understood in detail the Tender document issued vide above referenced NIT, hereby submit our “Bid” in full compliance with terms & conditions of Tender Document. A copy of the Tender Document, duly signed on each page is also submitted as a proof of our acceptance of all specifications as well as terms/ Conditions. I/ We have submitted the Bid in electronic form on ON-LINE mode at the Bidding Portal mentioned in the Tender Document.

2. (Insert this clause in case JV) I/We are submitted our Bid in form of Joint Venture, whereby M/s..... is the Lead Member and Partner, M/s..... is the other JV Partner. We have enclosed the Joint Deed of Undertaking executed by us in our Bid as per the requirement mentioned in the Tender Document.
3. I/We have selected Mr....., as our Authorized Signatory in our Bid. We have enclosed the Power of Attorney (POA) executed in favour of Authorized Signatory in our Bid as per the requirement mentioned in the Tender Document.
4. I/We have paid the requisite amount of EMD. I/we understand that without payment of the EMD by us, our offer shall out rightly be rejected.
5. If, I/we are selected and shortlisted for as successful Bidder, we agree pay the required Performance Security as per the terms & conditions mentioned in the Tender Document. I/We understand that I/we shall not be awarded the Contract if we fail to pay the Performance Security in stipulated time.
6. I/We agree to treat the Tender document and other records connected with the Scope of Work as secret and confidential documents and shall not communicate information described therein to any person other than the person authorized by you or use the information in any manner prejudicial to the safety requirement.
7. I/We understand that you are not bound to accept the lowest or any bid you may receive.
8. I/ We are participating, as Bidders, in not more than one Bid in this Bidding process.
9. I / We declare that our Bid is strictly in line with Tender Document Specification and there is no deviation. Further, I/We also agree that additional conditions / deviations, if any, found in our Bid, the Bid shall be out rightly rejected without assigning any reason thereof. We shall ensure that we execute such Bid documents as per the provisions of the NIT and provisions of such Tender Document shall be binding on us. I/We confirm that we have not taken any deviation so as to be deemed non-responsive.
10. I/We hereby unconditionally and irrevocably agree and accept that the decision made by JVVNL in respect of any matter regarding or arising out of the Bid submitted by us/ Tender Document issued by JVVNL shall be binding on us. We hereby expressly waive any and all claims in respect of Bid process.

11. I/ We confirm that there are no litigations or disputes against us, which materially affect our ability to fulfil our obligations with regard to execution of Project mentioned in the Tender Document.

12. I / We hereby submit our Bid and undertake to keep our Bid valid for a period of 6 months from the date of opening of Technical Bid. I / We hereby further undertake that during the said period, I / We shall not vary/alter or revoke my/ our Bid.

13. I/We also agree to abide by and fulfil all the terms, conditions and provisions of the above mentioned Tender documents.

Enclosed:

- 1. Summary Details of Bidder/ JV Partners**
- 2. Details of Material offered, Solar PV Modules, Configuration & Work execution capacity, existing & proposed after sales service centres in Rajasthan**

(Signature & Seal of Authorized Signatory for which POA attached)

Name of Authorized Signatory:

Designation:

Date:

Place:

J.7. Summary Details of Bidder

(On Letterhead of Bidder for which the said details are provided. In Case of JV the following format is to be provided by Each Member of the Joint Venture)

Summary Detail of Bidder

In Response to NIT No:	JVVNL/KUSUM-C/GRID-SPV/TN-04/2020 (Lot 1 to 10)
------------------------	----------------------------------------------------

S.No.	INFORMATION:	DETAILS:
1.	Name of Sole Bidder / Lead Member/ JV Partner:	
2.	Bidding Status	(JV / Sole Bidder)
3.	Status in JV: (Not applicable for Sole Bidder)	(Lead Member/ Other Partner)
4.	Registration status :	(Company/ LLP/ Partnership/ Sole Proprietor)
5.	Registration Number :	
6.	GST Registration Number:	
7.	PAN No:	
8.	Name of Key Contact Person: Email ID & Mobile No:	
9.	Registered office address of the Firm & Phone Number and E mail Ids :	
10.	Other Branch offices in India :	
11.	(i)	
12.	(ii)	
13.	(iii)	
14.	(iv)	
15.	Name of Directors of the Firm with Mobile Number and mail Ids :	
	Name :	Designation, Address, Mobile Number and Email ID :
	(i)	Designation, Address, Mobile Number and Email ID :
	(ii)	Designation, Address, Mobile Number and Email ID :
	(iii)	Designation, Address, Mobile Number and Email ID :
	(iv)	Designation, Address, Mobile

Revised Tender document for solarization of grid connected agriculture consumers

S.No.	INFORMATION:	DETAILS:
		Number and Email ID :
16.	Details of JV/Joint Venture Partner with Declaration of Lead Member	
17.	If Manufacturer of any item, the Name of products being manufactured :	
18.	Address of Manufacturing unit :	
19.	Brief details of firm's work experiences :	

(Signature & Seal of Authorized Signatory for which POA attached)

Name of Authorized Signatory:

Designation:

Date:

Place:

J.8. Details of Material to be Offered

(On Letterhead of Bidder/ Lead Member of JV)

In Response to NIT No:	JVVNL/KUSUM-C/GRID-SPV/TN-04/2020 (Lot 1 to 10)
------------------------	-------------------------------------------------

A. Details of All Materials

S.No.	Detail of material proposed for supply for different models as required in the Tender Document	Name of Manufacturer with whom Bidder has made MoU o supply material under this project	Manufacturing Country	Production Capacity of the material (per annum)	Tested from..... {Enclose the test certificate}
1.	SPV Modules				
2.	Invertors				
3.	SPV Controller				
4.	Module Mounting Structures				
5.	Other Material.....				
6.	Other Material.....				
7.	Other Material.....				
8.	Other Material.....				

Note:

- 1. Also power performance test data sheets of all modules. The exact power of the module shall be indicated if the data sheet consists of a range of modules with varying output power.**
2. Also provide complete technical data sheets for each equipment giving details of the specifications along with make/makes along with basic design of the PV Installation setup and power evacuation, synchronization along with protection equipment.

B. Details of Solar PV Modules

For Manufacturing of Solar PV Panels:

Name and Address of the Bidder's Supplier of SPV Modules:

.....

Sr. No.	Name of Equipment	Date of Purchase	Date of Calibration	Utility

C. Solar PV System Configuration of Respective Capacity (4.5 kWp, 7.5 kWp, 11.25 kWp)

<p>General Arrangement Drawing of Grid connected SPV Plant for solarization of Grid-connected Agriculture pump sets of Agriculture Consumers:</p>
<p>Brief description of configuration:</p>

D. Work execution Capacity per month for Supply, Installation, testing and commissioning of Grid connected PV System at Site on Agriculture Consumer premises where Agriculture Connection is located.

S. No.	SPV System Capacity	Per month Execution (Nos.)
1	4.5 kWp	
2	7.5 kWp	
3	11.25 kWp	
	Total	

E. Details of after sales service centres in Rajasthan

a. Existing

S. No.	Name of Dealer/centre	Village	Tehsil	District	Name of contact Person & Phone Number

b. Proposed

S. No.	Name of Dealer/centre	Village	Tehsil	District	Name of contact Person & Phone Number

(Signature & Seal of Authorized Signatory for which POA attached)

Name of Authorized Signatory:

Designation:

Date:

Place:

J.9. Details of Bidder’s Eligibility Requirements

(On Letterhead of Bidder/ Lead Member of JV)

Bidder’s Eligibility

In Response to NIT No:	JVVNL/KUSUM-C/GRID-SPV/TN-04/2020 (Lot 1 to 10)
------------------------	----------------------------------------------------

To

Superintending Engineer (Regulation)

Room No. 149, Old Power House Premises,
Banipark, Jaipur-302016

Sub: Bid for Tender for Work of Design, survey, supply, installation, testing, commissioning & 5 years comprehensive maintenance of distributed grid connected solar PV systems for solarization of grid connected agriculture consumers under “KUSUM Scheme – Component C” in Jaipur Discoms under TN-04/2020 (Lot 1 to 10).

Ref: NIT NO: JVJNL/KUSUM-C/GRID-SPV/TN-04/2020 (Lot 1 to 10) dated.....

We hereby declare that we are eligible for bidding in reference to “Eligibility Requirements” of the Tender Document vide above referenced NIT No. and submit the following certificate(s) /documents in support:

S. No.	Criteria	Documents Required	Status & Supporting Documents Attached
1.	Bidder Status – Bidder can be sole/ single bidder OR JV of up to 2 (two) members, with one of the members as a Lead Member	In case of JV, Deed of Undertaking	Status: Documents Attached: Yes/No (Attached at Annexure...to this letter)

Revised Tender document for solarization of grid connected agriculture consumers

S. No.	Criteria	Documents Required	Status & Supporting Documents Attached
2.	<p>The Bidder shall have any of the following legal status:</p> <p>a) Body incorporated in India under the Companies Act, 2013 including any amendment thereto; OR</p> <p>b) Body incorporated in India under the Limited Liability Partnership (LLP) Act, 2008 including any amendment thereto; OR</p> <p>c) Firm registered under Partnership Act, 1932 in India; OR</p> <p>d) Sole Proprietor</p> <p>In case of JV, all the members must fulfill this requirement and submit the documents as per the Tender Document.</p>	<p>a) In case of Company – Copy of Registration/ Incorporation Certificate</p> <p>b) In case of LLP – Copy of Deed of Partnership</p> <p>c) In case of Partnership – Copy of Deed of Partnership</p> <p>d) In case of Sole Proprietor – Duly notarized Undertaking from Sole proprietor</p>	<p>Status:</p> <p>Documents Attached: Yes/No</p> <p>(Attached at Annexure...to this letter)</p>
3.	<p>The Bidder shall have the required GST Registration</p> <p>In case of JV, all the members must fulfill this requirement.</p>	<p>Copy of GST registration certificate with legible GSTIN.</p>	<p>Status:</p> <p>Documents Attached: Yes/No</p> <p>(Attached at Annexure...to this letter)</p>
4.	<p>The Bidder must have valid PAN Number</p> <p>In case of JV, all the members must fulfill this requirement.</p>	<p>Copy of Pan Card</p>	<p>Status:</p> <p>Documents Attached: Yes/No</p> <p>(Attached at Annexure...to this letter)</p>
5.	<p>The Bidder should have Electrical contractor license of class "A"/"B" for Electrical works in Rajasthan.</p> <p>In case of non-availability of the same at the time of bid submission, the contractor should submit a valid electrical contractor license of Class "A"/"B" issued by Govt. of Rajasthan</p>	<p>Copy of Registration Certificate issued by Government of Rajasthan</p>	<p>Status:</p> <p>Documents Attached: Yes/No</p> <p>(Attached at Annexure...to this letter)</p>

Revised Tender document for solarization of grid connected agriculture consumers

S. No.	Criteria	Documents Required	Status & Supporting Documents Attached
	<p>within 1 month of award of contract. The bidder should submit an undertaking in this regard along with the bid.</p> <p>In case of JV, any one of the members must fulfill this requirement and submit the documents as per the Tender Document.</p>		
6.	<p>The Bidder shall be a manufacturer of solar panels or, solar water pump.</p> <p>In case of JV, any member must fulfill this requirement and the other partner should be engaged in the business of electrical works. The JV must submit the documents as per the Tender document.</p>	<p>Statutory Documents substantiating this requirement along with Documents submitted in Clause 2 of this Section above.</p>	<p>Status:</p> <p>Documents Attached: Yes/No</p> <p>(Attached at Annexure...to this letter)</p>
7.	<p>The bidder shall be having unblemished record and must not be blacklisted or declared ineligible for corrupt & fraudulent practices by “any state/ central government” / “any state / central government department/ company / entity” as on date of bid opening.</p> <p>In case of JV, all the members must fulfill this requirement.</p>	<p>The bidder shall provide an undertaking as per the format provided in SECTION - J: Format J.22.</p> <p>In case of JV, all the members must submit the undertaking as per the format provided in SECTION - J: Format J.22.</p>	<p>Status:</p> <p>Documents Attached: Yes/No</p> <p>Status:</p> <p>Documents Attached: Yes/No</p> <p>(Attached at Annexure...to this letter)</p>
8.	<p>The bidder must submit a Power of Attorney (POA) authorizing a person to sign the documents on behalf of the Bidder, submit technical, commercial information and attend meetings on behalf of the Bidder.</p>	<p>Sole Bidder to provide POA as per the applicable Law.</p> <p>In case of JV, Undertaking by JV as per the format provided in SECTION - J: (Format J.5) and POA as per the format provided in</p>	<p>Status:</p> <p>Documents Attached: Yes/No</p> <p>(Attached at Annexure...to this letter)</p>

S. No.	Criteria	Documents Required	Status & Supporting Documents Attached
		SECTION - J: (Format 0).	
9.	<p>The bidder should have “No Conflict of Interest” as defines in SECTION - F: clause F.11 of this tender document. Bidders have an obligation to disclose any situation of actual or potential conflict of interest. Failure to disclose said situations may lead to the disqualification of the Bidder or the termination of its Contract.</p> <p>In case of JV, all the members must fulfill this requirement.</p>	<p>The bidder shall provide an undertaking as per the format provided in as per the format provided in SECTION - J: (Format J.14)</p> <p>In case of JV, all the members shall submit the undertaking as per the format provided in SECTION - J: (Format J.14)</p>	<p>Status:</p> <p>Documents Attached: Yes/No</p> <p>(Attached at Annexure...to this letter)</p>

Supporting Documents enclosed.

(Supporting Documents, wherever required & applicable are to be attached at Annexure to this letter.....)

(Signature & Seal of Authorized Signatory for which POA attached)

Name of Authorized Signatory:

Designation:

Date:

Place:

J.10. Details of Bidder’s Qualification Requirements

(On Letterhead of Bidder/ Lead Member of JV)

Bidder’s Qualification

In Response to NIT No:	JVVNL/KUSUM-C/GRID-SPV/TN-04/2020 (Lot 1 to 10)
------------------------	-------------------------------------------------

To

Superintending Engineer (Regulation)

Room No. 149, Old Power House Premises,
Banipark, Jaipur-302016

Sub: Bid for Tender for Work of Design, survey, supply, installation, testing, commissioning & 5 years comprehensive maintenance of distributed grid connected solar PV systems for solarization of grid connected agriculture consumers under “KUSUM Scheme – Component C” in Jaipur Discoms TN-04/2020 (Lot 1 to 10).

Ref: NIT NO: JVVNL/KUSUM-C/GRID-SPV/TN -dated;

We hereby declare that we are eligible for bidding in reference to “Qualification Requirements” of the Tender Document vide above referenced NIT No. and submit the following certificate(s) /documents in support:

S. No.	Criteria	Documents Attached Details
1	Technical Criteria	
1.1	Bidder shall have experience of execution of supply, installation and maintenance of grid connected / off-grid Solar Photovoltaic Systems (SPV) (SPV Pumps / Rooftop SPV / Ground mounted SPV / Mini-grid / SPV home lighting) during last Five years [i.e. 2014-15 to 2018-19] OR, during 2015-16 to 31 st Dec 2019. The works shall have been executed under SNA/ Govt. Organization/SECI/PSUs only with total cumulative order value of not less than 50% of the estimated cost of the lot. In case of JV, both the partners should	Meeting Qualification: (Yes/No) Documents along with Format..... attached in Annexure....to this letter

Revised Tender document for solarization of grid connected agriculture consumers

S. No.	Criteria	Documents Attached Details
	<p>collectively meet the total work experience requirement i.e. total cumulative order value of works executed should not be less than 50% of the estimated cost of the lot(s).</p> <p>In case a bidder is quoting for more than one Lot, qualification requirement shall be sum of Lot wise requirements of all quoted Lots.</p>	
2	Financial Criteria	
2.1	<p>The Bidder shall have positive Net Worth for the each of the last three Financial Years (FY16-17, FY17-18, and FY18-19).</p> <p>In case of JV, all the partners of JV shall meet individually this qualification.</p>	<p>Meeting Qualification: (Yes/No)</p> <p>Documents along with Format..... attached in Annexure....to this letter</p>
2.2	<p>Minimum Average Annual Turnover (MAAT) during any 3 best out of last five financial years (FY14-15, FY15-16, FY16-17, FY17-18, and FY18-19) of the bidder shall not be less than 50% of estimated cost of the lot(s).</p> <p>In case a bidder is quoting for more than one Lot, qualification requirement shall be sum of Lot wise requirements of all quoted Lots.</p> <p>In case of JV, both the partners of the JV shall meet, collectively the qualification requirement. The figures for each of the partner of the joint venture shall be added together to determine the bidder's compliance with this qualifying criteria; however in order for a joint venture to qualify, the partner(s) of joint venture must meet the following minimum criteria:</p> <p>“The Lead partner shall meet not less than 40% AND the other partner shall meet not less than 30% of MAAT requirement. Collectively, JV shall meet the 100% requirement as in this MAAT qualification i.e. bidder's MAAT should not be less than 50% of estimated cost of the lot.”</p>	
2.3	Certificate from Banker	<p>Meeting Qualification: (Yes/No)</p> <p>Documents along with Format..... attached in Annexure....to this letter</p>

Supporting Documents enclosed.

(Supporting Documents, wherever required & applicable are to be attached at Annexure to this letter.....)

(Signature & Seal of Authorized Signatory for which POA attached)

Name of Authorized Signatory:

Designation:

Date:

Place:

J.11. Work Experience Certificate for Technical Qualification

(On Letterhead of Bidder/ Lead Member of JV)

Work Experience Certificate

In Response to NIT No:	JVVNL/KUSUM-C/GRID-SPV/TN-04/2020 (Lot 1 to 10)
------------------------	-------------------------------------------------

S. No.	Name of Bidder (In case of JV, name of Lead Member or Partner having experience)	Client Name	Description of Work	Work order		Stipulated completion Period	Date of commencement	Date of actual completion	Value of work actually executed (as per completion certificate) during under-mentioned years (Amt.in Rs. Lacs)						Remarks	
				No.& Date	Amount (Rs.in Lakhs)				FY 2014-15	FY 2015-16	FY 2016-17	FY 2017-18	FY 2018-19	First 9 months of FY 2019-20		Total
1																
2																
3																
4																
			TOTAL:													

(Signature & Seal of Authorized Signatory for which POA attached)

Name of Authorized Signatory:

Designation:

Date:

Place:

(Signature & Seal of Practicing Chartered Accountant)

Certifying Chartered Accountant:

Name of Firm:

UDIN No:

Date:

Place:

Note:

1. The details of projects executed during period mentioned above shall be listed in as per the above format. In support of above, Notarised Copy of work orders and a certificate issued by the SNA/ Govt. Organization/SECI/PSUs towards the satisfactory work completion to be furnished by the Bidder. The certificate shall not be issued by the officer below the equivalent rank of Executive Engineer of Concerned Entity. In absence of any one, it will not be considered for qualifying in technical bid.
2. Work experience Certificate having value of completed work in the name of Bidder duly certified by Practicing Chartered Accountant as per the format provided in SECTION - J: mentioning UDIN
3. In case of JV, both the partners should collectively meet the total work experience requirement i.e. total cumulative order value of works executed should not be less than 50% of the estimated cost of the lot(s).
4. The above details shall also be certified by the Chartered Accountant with their membership (UDIN) No. by sign and seal on each page of this format.

J.12. Certificate of Bidder's Financial Qualification

(On Letterhead of CA for the bidder (Bidder/ Lead Member/ Other Member) for which the below details are provided. In Case of JV the following format is to be provided by Each Member of the Joint Venture separately on their respective letterhead)

Financial Qualification Certificate

In Response to NIT No:	JVVNL/KUSUM-C/GRID-SPV/TN-04/2020 (Lot 1 to 10)
------------------------	-------------------------------------------------

(Rupees in Lakhs)

S. No.	Financial parameters	FY 2014-15	FY 2015-16	FY 2016-17	FY 2017-18	FY 2018-19
1.	Net Worth (only last three years)					
a)	Paid up Capital					
b)	Free Reserves and Surplus*					
c)	Misc expenses to the extent not written off					
	Net Worth (a+b-c)					
2.	Annual Turnover **					

* Free Reserve and Surplus shall be Exclusive of Revaluation Reserve, written back of Depreciation Provision and Amalgamation.

** Annual total Income/ turnover as incorporated in the Profit and Loss Account excluding non-recurring income, i.e. sale of fixed asset etc.

It is certified that all the figures are based on audited accounts read with auditors report and Notes to Accounts etc.

(Signature & Seal of Authorized Signatory for which POA attached)

Name of Authorized Signatory:

Designation:

Date:

Place:

Note:

(Signature & Seal of Practicing Chartered Account)

Certifying Chartered Accountant:

Name of Firm:

UDIN No:

Date:

Place:

1. In addition to above certificate from Chartered Accountant, Bidder is required to submit Firm's Annual Audit Report, Balance sheet, Profit & Loss and Income Tax Returns / CA certificate for last Five years i.e F.Y: 2014-15, 2015-16, 2016-17, 2017-18 & 2018-19.
2. **In case of JV, The form shall also be signed by respective entity's authorized signatory along with Authorized Signatory for which POA is attached.**

J.13. Certificate from Banker for Evidence of Access to or Availability of Credit/Facilities

(On Letterhead of Bank Issuing Certificate)

(In case of JV, this format is to be provided for each member including Lead Member)

In Response to NIT No:	JVVNL/KUSUM-C/GRID-SPV/TN-04/2020 (Lot 1 to 10)
------------------------	-------------------------------------------------

BANK CERTIFICATE

Date

This is to certify that M/s. _____ (*insert Name & Address of the Contractor*) _____ who have submitted their bid to Jaipur Vidyut Vitran Nigam Limited (JVVNL) for “the work of design, survey, supply, installation, testing, commissioning & 5 years comprehensive maintenance of distributed grid connected solar PV systems for solarization of grid connected agriculture consumers under “KUSUM Scheme – Component C” in Jaipur DISCOM, under NIT No: JVVNL/KUSUM-C/GRID-SPV/TN-04/2020 (Lot 1 to 10)”, is our customer for the past years.

Their financial transaction with our Bank have been satisfactory. They enjoy the following fund based and non-fund based limits including for guarantees, L/C and other credit facilities with us against which the extent of utilization as on date is also indicated below:

Sl. No.	Type of Facility	Sanctioned Limit as on Date	Utilisation as on Date

This letter is issued at the request of M/s. _____.

Signature _____

Name of Bank _____

Name of Authorised Signatory _____

Designation _____

Phone No. _____

Address _____

SEAL OF THE BANK

J.14. Declaration for Compliance with the Code of integrity and No Conflict of Interest

(On Letterhead of Bidder giving said declaration. In Case of JV the following format is to be provided by Each Member of the Joint Venture on their respective letterhead, signed by respective authorized Signatory along with Authorized Signatory for which POA is attached with Bid)

Declaration for Compliance with the Code of integrity and No Conflict of interest
(In Compliance to RTPP Act 2012 & RTPP Rules 2013)

In Response to NIT No:	JVVNL/KUSUM-C/GRID-SPV/TN-04/2020 (Lot 1 to 10)
------------------------	-------------------------------------------------

To

Superintending Engineer (Regulation)

Room No. 149, Old Power House Premises,
Banipark, Jaipur-302016

Sub: Bid for Tender for Work of Design, survey, supply, installation, testing, commissioning & 5 years comprehensive maintenance of distributed grid connected solar PV systems for solarization of grid connected agriculture consumers under “KUSUM Scheme – Component C” in Jaipur Discoms TN-04/2020 (Lot 1 to 10).

Ref: NIT NO: JVVNL/KUSUM-C/GRID-SPV/TN-04/2020 (Lot 1 to 10) dated;

We hereby declare that, we are in complete compliance of with the Code of integrity and No Conflict of interest as per Rajasthan Transparency in Public Procurement Act 2012 (RTPP Act 2012) & Rajasthan Transparency in Public Procurement Rules 2013 (RTPP Rules 2013), including any amendments issued thereafter.

A. Rule 80. Code of integrity.-

- (1) All the officers or employees of the procuring entity shall,-
 - (a) Maintain an unimpeachable standard of integrity both inside and outside their office;
 - (b) act in accordance with the provisions of the Act, these rules, guidelines issued under the Act and instructions;

- (c) Not allow any bidders to have access to information on a particular procurement, before such information is available to the public at large;
 - (d) Not intentionally use unnecessarily restrictive or “tailored” specifications, terms of reference or statements of work that can discourage competition;
 - (e) not solicit or accept any bribe, reward or gift or any material benefit of any directly or indirectly promise of future employment from anyone, who has sought or is seeking procurement from the procuring entity;
 - (f) not have a financial interest in any bidder(s) responding to a procuring entity’s bidding process and any person having financial interest in any bidder shall not participate in that procurement process;
 - (g) Not disclose proprietary and source selection information, directly or indirectly, to any person other than a person authorized to receive such information;
 - (h) Treat all bidders in a fair and equitable manner in line with the principle of fairness, integrity and transparency in the procurement process;
 - (i) provide all bidders identical information at the same time, during the bidding process;
 - (j) apply the same criteria of evaluation as specified in the bidding documents, bidder registration documents or pre-qualification documents and under no circumstances new evaluation criteria shall be introduced during the evaluation process;
 - (k) Not entertain any favour, recreation, presents, services, etc. from the bidders or prospective bidders;
 - (l) Protect the interests of the procuring entity under all circumstances while dealing with information and information sources;
 - (m) Maintain confidentiality of all bids;
 - (n) Ensure that the selection of bidder is as per the bidding documents and is not influenced by personal reasons attributable to concerned officials in any manner; and
 - (o) Disclose conflict of interest, if any.
- (2) Any person participating in procurement process shall,
- (a) not offer any bribe, reward or gift or any material benefit either directly or in directly in exchange for an unfair advantage in procurement process or to otherwise influence the procurement process;
 - (b) not misrepresent or omit information that misleads or attempts to mislead so as to obtain a financial or other benefit or avoid an obligation;
 - (c) not indulge in any collusion, bid rigging or anticompetitive behavior to impair the transparency, fairness and progress of the procurement process;
 - (d) not misuse any information shared between the procuring entity and the bidders with an intent to gain unfair advantage in the procurement process;

- (e) not indulge in any coercion including impairing or harming or threatening to do the same, directly or indirectly, to any party or to its property to influence the procurement process;
- (f) not obstruct any investigation or audit of a procurement process;
- (g) disclose conflict of interest, if any; and
- (h) disclose any previous transgressions with any entity in India or any other country during the last three years or any debarment by any other procuring entity.

B. Rule 81. Conflict of interest.-

- (i) A conflict of interest for procuring entity or its personnel and bidders is considered to be a situation in which a party has interests that could improperly influence that party's performance of official duties or responsibilities, contractual obligations, or compliance with applicable laws and regulations.
- (j) The situations in which a procuring entity or its personnel may be considered to be in conflict of interest includes, but not limited to, following:-
- (k) A conflict of interest occurs when procuring entity's personnel's private interests, such as outside professional or other relationships or personal financial assets, interfere or appear to interfere with the proper performance of its professional functions or obligations as a procurement official.
- (l) Within the procurement environment, a conflict of interest may arise in connection with such private interests as personal investments and assets, political or other outside activities and affiliations while in the service of the procuring entity, employment after retirement from the procuring entity's service or the receipt of a gift that may place the procuring entity's personnel in a position of obligation.
- (m) A conflict of interest also includes the use of procuring entity's assets, including human, financial and material assets, or the use of procuring entity's office or knowledge gained from official functions for private gain or to prejudice the position of someone procuring entity's personnel does not favour.
- (n) A conflict of interest may also arise in situations where procuring entity's personnel is seen to benefit, directly or indirectly, or allow a third party, including family, friends or someone they favour, to benefit from procuring entity's personnel's actions or decisions.
- (o) A Bidder may be considered to be in conflict of interest with one or more parties in a bidding process if, including but not limited to:-
- (p) they have controlling partners in common;
- (q) they receive or have received any direct or indirect subsidy from any of them;
- (r) they have the same legal representative for purposes of the bid;
- (s) they have a relationship with each other, directly or through common third parties, that puts them in a position to have access to information about or influence on the bid of another;

- (t) A bidder participates in more than one bid in the same bidding process. However, this does not limit the inclusion of the same sub-contractor, not otherwise participating as a bidder, in more than one bid; or
- (u) A bidder or any of its affiliates participated as a consultant in the preparation of the design or technical specifications of the subject matter of procurement of the bidding process. All bidders shall provide in Qualification Criteria and Bidding Forms, a statement that the bidder is neither associated nor has been associated directly or indirectly, with the consultant or any other entity that has prepared the design, specifications and other documents for the subject matter of procurement or being proposed as Project Manager for the contract.

C. Rule 82. Breach of code of integrity by the bidder.-Without prejudice to the provisions of Chapter IV of the Act, in case of breach of any provision of the code of integrity by a bidder or prospective bidder, as the case may be, the procuring entity may take appropriate action in accordance with the provisions of subsection (3) of section 11 and section 46.

(Signature & Seal of Authorized Signatory for which POA attached)

Name of Authorized Signatory:

Designation:

Date:

Place:

J.15. Declaration by the Bidder regarding Qualification

(On Letterhead of Bidder giving said declaration. In Case of JV the following format is to be provided by Each Member of the Joint Venture on their respective letterhead, signed by respective authorized Signatory along with Authorized Signatory for which POA is attached with Bid)

Declaration by the Bidder regarding Qualification RTPP Act 2012 & RTPP Rules 2013

(In Compliance to RTPP Act 2012 & RTPP Rules 2013)

In Response to NIT No:	JVVNL/KUSUM-C/GRID-SPV/TN-04/2020 (Lot 1 to 10)
------------------------	-------------------------------------------------

To

Superintending Engineer (Regulation)

Room No. 149, Old Power House Premises,
Banipark, Jaipur-302016

Sub: Bid for Tender for Work of Design, survey, supply, installation, testing, commissioning & 5 years comprehensive maintenance of distributed grid connected solar PV systems for solarization of grid connected agriculture consumers under “KUSUM Scheme – Component C” in Jaipur Discoms under TN-04/2020 (Lot 1 to 10).

Ref: NIT NO: JVVNL/KUSUM-C/GRID-SPV/TN-04/2020 (Lot 1 to 10) dated;

In relation to my/our Bid submitted to Jaipur Vidyut Vitran Nigam Limited, Jaipur (JVVNL) for the work of design, supply, installation, testing, commissioning & 5 years comprehensive maintenance of distributed grid connected solar PV systems for solarization of grid connected agriculture consumers under “KUSUM Scheme – Component C” in Jaipur Discoms in response to their Notice Inviting Bids No JVVNL/KUSUM-C/GRID-SPV/TN-04/2020 (Lot 1 to 10) Dated I/we hereby declare under Section 7 of Rajasthan Transparency in Public Procurement Act, 2012, that:

1. I/we possess the necessary professional, technical, financial and managerial resources and competence required by the Tender Document issued by JVVNL;
2. I/we have fulfilled my/our obligation to pay such of the taxes payable to the Union and the State Government or any local authority as specified in the Tender Document;

3. I/we are not insolvent, in receivership, bankrupt or being wound up, not have my/our affairs administered by a court or a judicial officer, not have my/our business activities suspended and not the subject of legal proceedings for any of the foregoing reasons;
4. I/we do not have, and our directors and officers not have, been convicted of any criminal offence related to my/our professional conduct or the making of false statements or misrepresentations as to my/our qualifications to enter into a procurement contract within a period of three years preceding the commencement of this procurement process, or not have been otherwise disqualified pursuant to debarment proceedings;
5. I/we do not have a conflict of interest as specified in the Act, Rules and the Bidding Document, which materially affects fair competition;

(Signature & Seal of Authorized Signatory for which POA attached)

Name of Authorized Signatory:

Designation:

Date:

Place:

J.16. Declaration by the Bidder regarding Grievance Redressal during Procurement Process

(On Letterhead of Bidder giving said declaration. In Case of JV the following format is to be provided by Each Member of the Joint Venture on their respective letterhead, signed by respective authorized Signatory along with Authorized Signatory for which POA is attached with Bid)

Declaration by the Bidder regarding Grievance Redressal during Procurement Process **(In Compliance to RTPP Act 2012 & RTPP Rules 2013)**

In Response to NIT No:	JVVNL/KUSUM-C/GRID-SPV/TN-04/2020 (Lot 1 to 10)
------------------------	-------------------------------------------------

To

Superintending Engineer (Regulation)

Room No. 149, Old Power House Premises,
Banipark, Jaipur-302016

Sub: Bid for Tender for Work of Design, survey, supply, installation, testing, commissioning & 5 years comprehensive maintenance of distributed grid connected solar PV systems for solarization of grid connected agriculture consumers under “KUSUM Scheme – Component C” in Jaipur Discom under TN-04/2020 (Lot 1 to 10).

Ref: NIT NO: JVVNL/KUSUM-C/GRID-SPV/TN-04/2020 (Lot 1 to 10) dated;

We hereby declare that, we are in complete agreement with the Grievance Redressal during Procurement process and will follow the same in all respects as per Rajasthan Transparency in Public Procurement Act 2012 (RTPP Act 2012) & Rajasthan Transparency in Public Procurement Rules 2013 (RTPP Rules 2013), including any amendments issued thereafter.

The designation of the First Appellate Authority is Managing Director, Jaipur Vidyut Vitran Nigam Limited (“JVVNL”/ “Jaipur Discom”) and the address is the Vidyut Bhawan at Jaipur, Rajasthan. The designation of the Second Appellate Authority is Chairman, Rajasthan Discoms, Jaipur address, Vidyut Bhawan, Near Vidhan Sabha, Jaipur.

“

Appeals

A. RTPP Rule 83. Form of Appeal.-

1. An appeal under sub-section (1) or (4) of section 38 shall be in Form along with as many copies as there are respondents in the appeal.

2. Every appeal shall be accompanied by an order appealed against, if any, affidavit verifying the facts stated in the appeal and proof of payment of fee.
3. Every appeal may be presented to First Appellate Authority or Second Appellate Authority, as the case may be, in person or through registered post or authorized representative.

B. Rule 84. Fee for filing appeal.-

1. Fee for first appeal shall be rupees two thousand five hundred and for second appeal shall be rupees ten thousand, which shall be nonrefundable.
2. The fee shall be paid in the form of bank demand draft or banker's cheque of a Scheduled Bank payable in the name of Appellate Authority concerned.

C. Rule 85. Procedure for disposal of appeal.-

1. The First Appellate Authority or Second Appellate Authority, as the case may be, upon filing of appeal, shall issue notice accompanied by copy of appeal, affidavit and documents, if any, to the respondents and fix date of hearing.
2. On the date fixed for hearing, the First Appellate Authority or Second Appellate Authority, as the case may be, shall,
 - i. hear all the parties to appeal present before him; and
 - ii. peruse or inspect documents, relevant records or copies thereof relating to the matter.
 - iii. After hearing the parties, perusal or inspection of documents and relevant records or copies thereof relating to the matter, the Appellate Authority concerned shall pass an order in writing and provide the copy of order to the parties to appeal free of cost.
 - iv. The order passed under sub-rule (3) shall also be placed on the State Public Procurement Portal.

- D. Rule 86. Repeal and savings.-**All rules, regulations, orders, notifications, departmental codes, manuals, by-laws, official memoranda or circulars relating to procurement of goods, services or works provided for in these rules, which are in force on the date of commencement of these rules, in relation to the matter covered by these rules are hereby repealed to the extent they are covered by these rules:

Provided that such repeal shall not affect the previous operation of rules, regulations, orders, notifications, departmental codes, manuals, by-laws, official memoranda or circulars, so repealed and the procurement process commenced before the commencement of these rules shall continue as per the provisions of rules, regulations, orders, notifications, departmental codes, manuals, by-laws, official memoranda or circulars, so repealed.

FORM No. 1

[See rule 83]

Memorandum of Appeal under the Rajasthan Transparency in Public Procurement Act, 2012

Appeal NoofBefore the(First / Second Appellate Authority)

1. Particulars of appellant:

(i) Name of the appellant:

(ii) Official address, if any:

(iii) Residential address:

2. Name and address of the respondent(s):

(i)

(ii)

(iii)

3. Number and date of the order appealed against and name and designation of the officer / authority who passed the order (enclose copy), or a statement of a decision, action or omission of the procuring entity in contravention to the provisions of the Act by which the appellant is aggrieved:

4. If the Appellant proposes to be represented by a representative, the name and postal address of the representative:

5. Number of affidavits and documents enclosed with the appeal:

6. Grounds of appeal:

.....
.....
.....

.....(Supported by an affidavit)

7. Prayer:

.....
.....
.....

Place

Date

Appellant's Signature

...

(Signature & Seal of Authorized Signatory for which POA attached)

Name of Authorized Signatory:

Designation:

Date:

Place:

J.17. Declaration by the Bidder regarding Additional Condition of Tender Document/ Contract

(On Letterhead of Bidder giving said declaration. In Case of JV the following format is to be provided by Each Member of the Joint Venture on their respective letterhead, signed by respective authorized Signatory along with Authorized Signatory for which POA is attached with Bid)

Declaration by the Bidder regarding Additional Condition of Tender Document/ Contract

(In Compliance to RTPP Act 2012 & RTPP Rules 2013)

In Response to NIT No:	JVVNL/KUSUM-C/GRID-SPV/TN-04/2020 (Lot 1 to 10)
------------------------	-------------------------------------------------

To

Superintending Engineer (Regulation)

Room No. 149, Old Power House Premises,
Banipark, Jaipur-302016

Sub: Bid for Tender for Work of Design, survey, supply, installation, testing, commissioning & 5 years comprehensive maintenance of distributed grid connected solar PV systems for solarization of grid connected agriculture consumers under “KUSUM Scheme – Component C” in Jaipur Discoms under TN-04/2020 (Lot 1 to 10).

Ref: NIT NO: JVVNL/KUSUM-C/GRID-SPV/TN-04/2020 (Lot 1 to 10) dated;

We hereby declare that, we are in complete agreement with the Additional Conditions of Tender Document/ Contract and will follow the same in all respects as per Rajasthan Transparency in Public Procurement Act 2012 (RTPP Act 2012) & Rajasthan Transparency in Public Procurement Rules 2013 (RTPP Rules 2013), including any amendments issued thereafter.

“.....

1. Correction of arithmetical errors

Provided that a Financial Bid is substantially responsive, Jaipur Vidyut Vitran Nigam Limited, (“JVVNL”) will correct arithmetical errors during evaluation of Financial Bids on the following basis:

- i. if there is a discrepancy between the unit price and the total price that is obtained by multiplying the unit price and quantity, the unit price shall prevail and the total price shall be corrected, unless in the opinion of JVVNL there is an obvious misplacement of the decimal point in the unit price, in which case the total price as quoted shall govern and the unit price shall be corrected;
- ii. if there is an error in a total corresponding to the addition or subtraction of subtotals, the subtotals shall prevail and the total shall be corrected; and
- iii. if there is a discrepancy between words and figures, the amount in words shall prevail, unless the amount expressed in words is related to an arithmetic error, in which case the amount in figures shall prevail subject to (i) and (ii) above.

If the Bidder that submitted the lowest evaluated Bid does not accept the correction of errors, its Bid shall be disqualified and its Bid Security shall be forfeited or its Bid Securing Declaration shall be executed.

2. Discom's Right to Vary Quantities

- i. At the time of award of contract, the quantity of Goods, works or services originally specified in the Bidding Document may be increased or decreased by a specified percentage, but such increase or decrease shall not exceed fifty percent, but may be decreased as per requirement of Discom, of the quantity specified in the Bidding Document. It shall be without any change in the unit prices or other terms and conditions of the Bid and the conditions of contract.
- ii. If the Discom does not procure any subject matter of procurement or procures less than the quantity specified in the Bidding Document due to change in circumstances, the Bidder/ Successful Bidder/ Contractor shall not be entitled for any claim or compensation except otherwise provided in the Conditions of Contract.
- iii. In case of procurement of Goods or services, additional quantity may be procured by placing a repeat order on the rates and conditions of the original order. However, the additional quantity can be upto 50% of the value of Goods of the original contract/work order and shall be within one month from the date of expiry of last supply. If the Contractor fails to do so, Discom shall be free to arrange for the balance supply by limited Bidding or otherwise and the extra cost incurred shall be recovered from the Contractor.

.....”

(Signature & Seal of Authorized Signatory for which POA attached)

Name of Authorized Signatory:

Designation:

Date:

Place:

J.18. Declaration Regarding Alternative, Deviations and Exceptions to the Provisions

(On Letterhead of Bidder/ Lead Member of JV)

Declaration by the Bidder regarding Alternative, Deviations & Exceptions to Provisions

In Response to NIT No:	JVVNL/KUSUM-C/GRID-SPV/TN-04/2020 (Lot 1 to 10)
------------------------	-------------------------------------------------

To

Superintending Engineer (Regulation)

Room No. 149, Old Power House Premises,

Banipark, Jaipur-302016

Sub: Bid for Tender for Work of Design, survey, supply, installation, testing, commissioning & 5 years comprehensive maintenance of distributed grid connected solar PV systems for solarization of grid connected agriculture consumers under “KUSUM Scheme – Component C” in Jaipur Discom under TN-04/2020 (Lot 1 to 10).

Ref: NIT NO: JVVNL/KUSUM-C/GRID-SPV/TN-04/2020 (Lot 1 to 10) dated;

Dear Sir,

The bidder shall itemize any deviation from the Tender Document included in his bid. Each item shall be listed (separate sheets may be used and enclosed with this Attachment) with the following information:

Sl. No.	Reference clause in the Tender Document	Deviation	Cost of withdrawal of the deviation
1			
2			
3			

The above deviations and variations are exhaustive. We confirm that we shall withdraw the deviations proposed by us at the cost of withdrawal indicated in this attachment, failing which our bid may be rejected and Bid Security forfeited.

Except for the above deviations and variations, the entire work shall be performed as per your specifications and documents. Further, we agree that any deviations, conditionality or reservation introduced in this Declaration and/or in the Bid submitted, Price schedules &

Technical Data Sheets and covering letter, or in any other part of the Bid will be reviewed to conduct a determination of the substantial responsiveness of the Bid.

(Signature & Seal of Authorized Signatory for which POA attached)

Name of Authorized Signatory:

Designation:

Date:

Place:

J.19. Declaration Regarding No Omissions or Inconsistencies or Reservations

(On Letterhead of Bidder/ Lead Member of JV)

Declaration by the Bidder regarding No Omissions or Inconsistencies or Reservations

In Response to NIT No:	JVVNL/KUSUM-C/GRID-SPV/TN-04/2020 (Lot 1 to 10)
------------------------	-------------------------------------------------

To

Superintending Engineer (Regulation)

Room No. 149, Old Power House Premises,

Banipark, Jaipur-302016

Sub: Bid for Tender for Work of Design, survey, supply, installation, testing, commissioning & 5 years comprehensive maintenance of distributed grid connected solar PV systems for solarization of grid connected agriculture consumers under “KUSUM Scheme – Component C” in Jaipur Discom under TN-04/2020 (Lot 1 to 10).

Ref: NIT NO: JVVNL/KUSUM-C/GRID-SPV/TN-04/2020 (Lot 1 to 10) dated;

Dear Sir,

We confirm that Bid submitted by us and have been filled up by us as per the provisions of the Tender Document issued vide above-referenced NIT. We have also uploaded price bid electronically as per the provisions of the Tender Document. Further, we have noted that the same shall be evaluated as per the provisions of the Tender Document.

Further, we hereby confirm that except as mentioned in the Declaration Regarding Alternative, Deviations and Exceptions to the Provisions hereof and/or the Covering Letter, forming part of our Bid Envelope:

- (i) There are no discrepancies/inconsistencies and deviations/omissions/ reservations to the Tender Document, in the price bid;
- (ii) The description of items and the unit thereof in the price schedules are in conformity with those indicated in the price schedule of the Tender Document without any deviation to the specified scope of work.

We also confirm that in case any discrepancies/ inconsistencies and deviations/ omissions/ reservations, as referred to in para (i) and (ii) above, is observed in the online price bid, the same shall be deemed as withdrawn/rectified without any financial implication, whatsoever to JVVNL. However, in case of any arithmetical errors, the same shall be governed as per the provisions of Tender Document SECTION - F:(13.1.4).

(Signature & Seal of Authorized Signatory for which POA attached)

Name of Authorized Signatory:

Designation:

Date:

Place:

J.20. Integrity Pact

(On Letterhead of Bidder giving said declaration. In Case of JV the following format is to be provided by Lead Member which shall be signed by all the partners of Joint Venture. The Bidder shall submit the Integrity Pact on a non-judicial stamp paper of Rs. 100/- duly notarised. The Integrity Pact is to be prepared in Two (2) Original Copies)

(INTEGRITY PACT)

General

This pre-bid pre-contract Agreement (hereinafter called the Integrity Pact) is made on day of the month of 2010, between, on one hand, the{ Jaipur, as applicable} Vidyut Vitran Nigam Limited,..... { Jaipur Discom) acting through Shri..... (Name and designation of Authorized Representative of Discom/ Employer) (Hereinafter called the "Discom", which expression shall mean and include, unless *the* context otherwise requires, his successors in office and assigns) of the First Part and M/s..... (Name of Bidder/ JV Member / Lead Member) represented by Shri, Chief Executive Officer (hereinafter called the "Bidder / Contractor" which expression shall mean and include, unless the context otherwise requires, his successors and permitted assigns) of the Second Part.

WHEREAS the Discom proposes to hire eligible Bidder/ Contractor for executing the work of design, survey, supply, installation, testing, commissioning & 5 years comprehensive maintenance of distributed grid connected solar PV systems for solarization of grid connected agriculture consumers under “KUSUM Scheme – Component C” in Jaipur Discoms, under NIT No: JVVNL/KUSUM-C/GRID-SPV/TN-04/2020 (Lot 1 to 10) (hereinafter referred to as “Scope of Work”) and the Bidder / Contractor is willing to offer/has offered “proposal/ bid” for the said Tender.

WHEREAS the Bidder/ Contractor is a private company/ public company/ Government undertaking / limited liability partnership / partnership firm/ sole proprietorship entity, constituted in accordance with the relevant Law in the matter and the Discom is a Utility of Rajasthan State Government performing its functions on behalf of the Government of Rajasthan (Name of Owner).

NOW, THEREFORE,

To avoid all forms of corruption by following a system that is fair, transparent and free from any influence/prejudiced dealings prior to, during and subsequent to the currency of the contract to be entered into with a view to :-

Enabling the Discom to obtain the desired Scope of Work at a competitive price in

conformity with the defined specifications by avoiding the high cost and the distortionary impact of corruption on public procurement, and

Enabling Bidder/ Contractor to abstain from bribing or indulging in any corrupt practice in order to secure the contract by providing assurance to them that their competitors will also abstain from bribing and other corrupt practices and the Discom will commit to prevent corruption, in any form, by its officials by following transparent procedures.

The parties hereto hereby agree to enter into this Integrity Pact and agree as follows:

1. Commitments of the Discom

- 1.1. The Discom undertakes that no official of the Bidder/ Contractor, connected directly or indirectly with the contract, will demand, take a promise for or accept, directly or through intermediaries, any bribe, consideration, gift, reward, favour or any material or immaterial benefit or any other advantage from the Bidder/ Contractor, either for themselves or for any person, organisation or third party related to the contract in exchange for an advantage in the bidding process, bid evaluation, contracting or implementation process related to the contract.
- 1.2. The Discom will, during the pre-contract stage, treat all Bidder(s) alike and will provide to all Bidder(s) the same information and will not provide any such information to any particular Bidder which could afford an advantage to that particular Bidder in comparison to other Bidder(s).
- 1.3. All the officials of the Discom will report to the appropriate Government office any attempted or completed breaches of the above commitments as well as any substantial suspicion of such a breach.
- 1.4. In case any such preceding misconduct on the part of such official(s) is reported by the Bidder/ Contractor to the Discom with full and verifiable facts and the same is prima facie found to be correct by the Discom, necessary disciplinary proceedings, or any other action as deemed fit, including criminal proceedings may be initiated by the Discom and such a person shall be debarred from further dealings related to the contract process. In such a case while an enquiry is being conducted by the Discom the proceedings under the contract would not be stalled.

2. Commitments of Bidder(s)

- 2.1. The Bidder commits itself to take all measures necessary to prevent corrupt practices, unfair means and illegal activities during any stage of its bid or during any pre-

contract or post-contract stage in order to secure the contract or in furtherance to secure it and in particular commit itself to the following:-

- 2.2. The Bidder will not offer, directly or through intermediaries, any bribe, gift, consideration, reward, favour, any material or immaterial benefit or other advantage, commission, fees, brokerage or inducement to any official of the Discom, connected directly or indirectly with the bidding process, or to any person, organisation or third party related to the contract in exchange for any advantage in the bidding, evaluation, contracting and implementation of the contract.
- 2.3. The Bidder further undertakes that it has not given, offered or promised to give, directly or indirectly any bribe, gift, consideration, reward, favour, any material or immaterial benefit or other advantage, commission, fees, brokerage or inducement to any official of the Discom or otherwise in procuring the Contract or forbearing to do or having done any act in relation to the obtaining or execution of the contract or any other contract with the Government for showing or for bearing to show favour or disfavour to any person in relation to the contract or any other contract with Government.
- 2.4. Bidder(s) shall disclose the name and address of agents and representatives and Indian Bidder(s) shall disclose their foreign principals or associates.
- 2.5. Bidder(s) shall disclose the payments to be made by them to agents/brokers or any other intermediary, in connection with this bid/contract.
- 2.6. The Bidder further confirms and declares to the Discom that the Bidder is the original manufacturer/integrator/authorised government sponsored export entity of the defence stores and has not engaged any individual or firm or company whether Indian or foreign to intercede, facilitate or in any way to recommend to the Discom or any of its functionaries, whether officially 'or unofficially to the award of the contract to the Bidder, nor has any amount been paid, promised or intended to be paid to any such individual, firm or company in respect of any such intercession, facilitation or recommendation.
- 2.7. The Bidder, either while presenting the bid or during pre-contract negotiations or before signing the contract, shall disclose any payments he has made, is committed to or intends to make to officials of the Discom or their family members, agents, brokers or any other intermediaries in connection with the contract and the details of services agreed upon for such payments.
- 2.8. The Bidder will not collude with other parties interested in the contract to impair the transparency, fairness and progress of the bidding process, bid evaluation, contracting and implementation of the contract.

- 2.9. The Bidder will not accept any advantage in exchange for any corrupt practice, unfair means and illegal activities.
- 2.10. The Bidder shall not use improperly, for purposes of competition or personal gain, or pass on to others, any information provided by the Discom as part of the business relationship, regarding plans, technical proposals and business details, including information contained in any electronic data carrier. The Bidder also undertakes to exercise due and adequate care lest any such information is divulged.
- 2.11. The Bidder commits to refrain from giving any complaint directly or through any other manner without supporting it with full and verifiable facts.
- 2.12. The Bidder shall not instigate or cause to instigate any third person to commit any of the actions mentioned above.
- 2.13. If the Bidder or any employee of the Bidder or any person acting on behalf of the Bidder, either directly or indirectly, is a relative of any of the officers of the Discom, or alternatively, if any relative of an officer of the Bidder has financial interest/stake in the Bidder's firm, the same shall be disclosed by the Bidder at the time of filing of bid in response to tender.
- 2.14. The term 'relative' for this purpose would be as defined in Section 6 of the Companies Act 1956.
- 2.15. The Bidder shall not lend to or borrow any money from or enter into any monetary dealings or transactions, directly or indirectly, with any employee of the Discom.

3. Previous Transgression

- 3.1. The Bidder declares that no previous transgression occurred in the last three years immediately before signing of this Integrity Pact, with any other company in any country in respect of any corrupt practices envisaged hereunder or with any Public Sector Enterprise in India or any Government Department in India that could justify Bidder's exclusion from the tender process.
- 3.2. The Bidder agrees that if it makes incorrect statement on this subject, Bidder can be disqualified from the tender process or the contract, if already awarded, can be terminated for such reason.

4. Bid Security

- 4.1. While submitting commercial bid, the Bidder shall deposit bid security for the amount specified in Tender Document/ NIT, with the Discom through any of the following instruments:
 - 4.1.1. Bank Draft or a Pay Order in favour of
 - 4.1.2. A confirmed guarantee by from a reputed (i) Public Sector Bank located in India; or (ii) Scheduled Commercial Indian Private Bank as per the attached list only [List is placed at SECTION - B: Key Bid Data of Tender Document], promising payment of the guaranteed sum to the Discom on demand within three working days without any demur whatsoever and without seeking any reasons whatsoever. The demand for payment by the Discom shall be treated as conclusive proof of payment.
 - 4.1.3. Any other mode or through any other instrument (as specified in Tender Document).
- 4.2. The Bid Security shall be valid upto a period of 6 months plus (+) 30 days of grace period “from the date of opening of Technical Bid” or the complete conclusion of the contractual obligations to the complete satisfaction of both the Bidder and the Discom, including warranty period, whichever is later.
- 4.3. In case of the successful Bidder, a clause would also be incorporated in the Article pertaining to Performance Security in the' Contract Agreement that the provisions of Sanctions for Violation shall be applicable for forfeiture of Performance Security in case of a decision by the Discom to forfeit the same without assigning any reason for imposing sanction for violation of this Pact.
- 4.4. No interest shall be payable by the Discom to the Bidder on Bid Security for the period of its currency.

5. Sanctions for Violations

- 5.1. Any breach of the aforesaid provisions by the Bidder or anyone employed by it or acting on its behalf (whether with or without the knowledge of the Bidder) shall entitle the Discom to take all or any one of the following actions, wherever required:-
 - 5.1.1. To immediately call off the pre contract negotiations without assigning any reason or giving any compensation to the Bidder. However, the proceedings with the other Bidder(s) would continue.
 - 5.1.2. The Bid Security (in pre-contract stage) and/or Performance Security (after the contract is signed) shall stand forfeited either fully or partially, as decided by the Discom and the Discom shall not be required to assign any reason therefore.

- 5.1.3. To immediately cancel the contract, if already signed, without giving any compensation to the Bidder.
 - 5.1.4. To recover all sums already paid by the Discom, and in case of an Indian Bidder with interest thereon at 2% higher than the prevailing Prime Lending Rate of State Bank of India, while in case of a Bidder from a country other than India with interest thereon at 2% higher than the UBOR. If any outstanding payment is due to the Bidder from the Discom in connection with any other contract for any other stores, such outstanding payment could also be utilized to recover the aforesaid sum and interest.
 - 5.1.5. To encash the advance bank guarantee (if applicable) and Performance Security, if furnished by the Bidder, in order to recover the payments, already made by the Discom, along with interest.
 - 5.1.6. To cancel all or any other Contracts with the Bidder. The Bidder shall be liable to pay compensation for any loss or damage to the Discom resulting from such cancellation/rescission and the Discom shall be entitled to deduct the amount so payable from the money(s) due to the Bidder.
 - 5.1.7. To debar the Bidder from participating in future bidding processes of the Government of India for a minimum period of five years, which may be further extended at the discretion of the Discom.
 - 5.1.8. To recover all sums paid in violation of this Pact by Bidder(s) to any middleman or agent or broker with a view to securing the contract.
 - 5.1.9. In cases where irrevocable Letters of Credit have been received in respect of any contract signed by the Discom with the Bidder, the same shall not be opened.
 - 5.1.10. Forfeiture of Performance Security in case of a decision by the Discom to forfeit the same without assigning any reason for imposing sanction for violation of this Pact.
- 5.2. The Discom will be entitled to take all or any of the actions mentioned at para 5.1.1 to 5.1.10 of this Pact also on the Commission by the Bidder or anyone employed by it or acting on its behalf (whether with or without the knowledge of the Bidder), of an offence as defined in Chapter IX of the Indian Penal code, 1860 or Prevention of Corruption Act, 1988 or any other statute enacted for prevention of corruption.
- 5.3. The decision of the Discom to the effect that a breach of the provisions of this Pact has been committed by the Bidder shall be final and conclusive on the Bidder. However, the Bidder can approach the Independent Monitor(s) appointed for the purposes of this Pact.

6. Fall Clause

- 6.1. The Bidder undertakes that it has not supplied/is not supplying similar product/systems or subsystems at a price lower than that offered in the present bid in respect of any other Ministry/Department of the Government of India or PSU and if it is found at any stage that similar product/systems or sub systems was

supplied by the Bidder to any other Ministry/Department of the Government of India or a PSU at a lower price, then that very price, with due allowance for elapsed time, will be applicable to the present case and the difference in the cost would be refunded by the Bidder to the Discom, if the contract has already been concluded.

7. Independent Monitors

- 7.1. The Discom has appointed Independent Monitors (hereinafter referred to as Monitors) for this Pact in consultation with the Central Vigilance to as Monitors) for this Pact in consultation with the Central Vigilance Commission (Names and Addresses of the Monitors to be given).
- 7.2. The task of the Monitors shall be to review independently and objectively, whether and to what extent the parties comply with the obligations under this Pact.
- 7.3. The Monitors shall not be subject to instructions by the representatives of the parties and perform their functions neutrally and independently.
- 7.4. Both the parties accept that the Monitors have the right to access all the documents relating to the project/procurement, including minutes of meetings.
- 7.5. As soon as the Monitor notices, or has reason to believe, a violation of this Pact, he will so inform the Authority designated by the Discom.
- 7.6. The Bidder(s) accepts that the Monitor has the right to access without restriction to all Project documentation of the Discom including that provided by the Bidder. The Bidder will also grant the Monitor, upon his request and demonstration of a valid interest, unrestricted and unconditional access to his project documentation. The same is applicable to Subcontractors. The Monitor shall be under contractual obligation to treat the information and documents of the Bidder/Subcontractor(s) with confidentiality.
- 7.7. The Discom will provide to the Monitor sufficient information about all meetings among the parties related to the Project provided such meetings could have an impact on the contractual relations between the parties. The parties will offer to the Monitor the option to participate in such meetings.
- 7.8. The Monitor will submit a written report to the designated Authority of Discom/Secretary in the Department/ within 8 to 10 weeks from the date of reference or intimation to him by the Discom/ Bidder and, shall the occasion arise, submit proposals for correcting problematic situations.

8. Facilitation of Investigation

- 8.1. In case of any allegation of violation of any provisions of this Pact or payment of commission, the Discom or its agencies shall be entitled to examine all the documents including the Books of Accounts of the Bidder and the Bidder shall provide necessary information and documents in English and shall extend all possible help for the purpose of such examination.

9. Law and Place of Jurisdiction

9.1. This Pact is subject to Indian Law. The place of performance and jurisdiction is the seat of the Discom.

10. Other Legal Actions

10.1. The actions stipulated in this Integrity Pact are without prejudice to any other legal action that may follow in accordance with the provisions of the extant law in force relating to any civil or criminal proceedings

11. Validity

11.1. The validity of this Integrity Pact shall be from date of its signing and extend upto 5 years or the complete execution of the contract to the satisfaction of both the Discom and the Bidder/ Contractor, including warranty period, whichever is later. In case Bidder is unsuccessful, this Integrity Pact shall expire after six months from the date of the signing of the contract.

11.2. Shall one or several provisions of this Pact turn out to be invalid; the remainder of this Pact shall remain valid. In this case, the parties will strive to come to an agreement to their original intentions.

The parties hereby sign this Integrity Pact aton.....

BUYER
Name of the Officer
Designation
Deptt./PSU

BIDDER
CHIEF EXECUTIVE OFFICER

Witness
1.....
2.....

Witness
2.....
3.....

*** Provisions of these clauses would need to be amended/ deleted in line with the policy of the BUYER in regard to involvement of Indian agents of foreign suppliers**

J.21. Bank Guarantee Verification Check-list

Bank Guarantee Verification Check-List

(On Letterhead of Bidder/ Lead Member of JV)

In Response to NIT No:	JVVNL/KUSUM-C/GRID-SPV/TN-04/2020 (Lot 1 to 10)
------------------------	-------------------------------------------------

To

Superintending Engineer (Regulation)

Room No. 149, Old Power House Premises,
Banipark, Jaipur-302016

Sub: Bid for Tender for Work of Design, survey, supply, installation, testing, commissioning & 5 years comprehensive maintenance of distributed grid connected solar PV systems for solarization of grid connected agriculture consumers under “KUSUM Scheme – Component C” in Jaipur Discom under TN-04/2020 (Lot 1 to 10).

Ref: NIT NO: JVJNL/KUSUM-C/GRID-SPV/TN-04/2020 (Lot 1 to 10) dated;

S. No.	Checklist	Yes	No
1	Does the bank guarantee compare verbatim with standard proforma for BG?		
2(a)	Has the executing Officer of BG indicated his name designation & Power of Attorney No. / Signing power Number etc. on BG?		
2(b)	Is each page of BG duly Signed/ initialed by the executants and last page is signed with full particulars as required in the standard proforma of BG and under the seal of the bank?		
2(c)	Does the last page of the BG carry the signatures of two witnesses alongside the signature of the executing Bank Manager?		
3(a)	Is the BG on non-judicial stamp paper of appropriate value?		
3(b)	Is the date of sale of non-judicial stamp paper shown on the BG and the stamp paper is issued not more than Six months prior to the date of execution of BG?		
4(a)	Are the factual details such as Bid specification No., LOA No. contract price, etc, correct?		

Revised Tender document for solarization of grid connected agriculture consumers

S. No.	Checklist	Yes	No
4(b)	Whether Overwriting /cutting, if any on the BG, authenticated under signature & seal of executants?		
5	Is the amount and validity of BG is in line with contract provisions?		
6	Whether the BG has been issued by a reputed (i) Public Sector Bank located in India; or (ii) Scheduled Commercial Indian Private Bank as per the attached list only [List is placed at BDS] (the applicability of the bank shall be in line with the provisions of bidding documents)?		

(Signature & Seal of Authorized Signatory for which POA attached)

Name of Authorized Signatory:

Designation:

Date:

Place:

J.22. Undertaking for No Blacklisting & No Banning

(On Letterhead of Bidder giving said declaration. In Case of JV the following format is to be provided by Each Member of the Joint Venture on their respective letterhead, signed by respective authorized Signatory along with Authorized Signatory for which POA is attached with Bid)

(On Non-Judicial Stamp Paper of Rs. 100/- attested by Notary Public/ First Class Magistrate)

Undertaking for No Blacklisting & No Banning

To

Superintending Engineer (Regulation)

Room No. 149, Old Power House Premises,

Banipark, Jaipur-302016

Sub: Bid for Tender for Work of Design, survey, supply, installation, testing, commissioning & 5 years comprehensive maintenance of distributed grid connected solar PV systems for solarization of grid connected agriculture consumers under “KUSUM Scheme – Component C” in Jaipur Discom under TN-04/2020 (Lot 1 to 10).

Ref: NIT NO: JVVNL/KUSUM-C/GRID-SPV/TN-04/2020 (Lot 1 to 10) dated;

I / We hereby declare that presently our Company/Limited Liability Partnership/ Partnership Firm/ Sole Proprietorship is having unblemished record and is not declared ineligible for corrupt/fraudulent practices by any State/Central Government/PSU on the date of Bid Submission.

I / We further declare that presently our Company/Limited Liability Partnership/ Partnership Firm/ Sole Proprietorship is not blacklisted and not declared ineligible for reasons other than corrupt/fraudulent practices by any State/Central Government/PSU on the date of Bid Submission.

If this declaration is found to be incorrect then without prejudice to any other action that may be taken, our security may be forfeited in full and the tender if any to the extent accepted may be cancelled.

(Signature & Seal of Authorized Signatory for which POA attached)

Name of Authorized Signatory:

Designation:

Date:

Place:

J.23. Price Bid (To be submitted in MS Excel File online)

(This format is just for reference and is not to be submitted in Technical Bid or hard copy. This is to be submitted only online in Cover – 3 in MS Excel File)

Bidder shall quote rates / costs in the format given in MS Excel File on Bidding Portal for Work of Design, survey, supply, installation, testing, commissioning & 5 years comprehensive maintenance of distributed grid connected solar PV systems for solarization of grid connected agriculture consumers under “KUSUM Scheme – Component C” in Jaipur Discom under NIT No: JVVNL/KUSUM-C/GRID-SPV/TN-04/2020 (Lot 1 to 10) (FOR Site Basis)

<div style="text-align: right; color: red;">Item Rate BoQ</div> <div style="font-size: small;"> Validate Print Help Tender Inviting Authority: Superintending Engineer (Regulation), Jaipur Vidyut Vitran Nigam Limited (JVVNL) Name of Work: Design, survey, supply, installation, testing, commissioning & 5 years comprehensive maintenance of distributed grid connected solar PV systems for solarization of grid connected agriculture consumers under “KUSUM Scheme - Component C” in Jaipur Discom Contract No: JVVNL/KUSUM-C/GRID-SPV/TN-04/2020 (Lot 1) </div>															
PRICE SCHEDULE															
(This BOQ template must not be modified/replaced by the bidder and the same should be uploaded after filling the relevant columns, else the bidder is liable to be rejected for this tender. Bidders are allowed to enter the Bidder Name and Values only)															
Sl. No.	Type of Required SPV Systems as per specifications and requirement of tender document	Quantity	Units	Per SPV system unit Supply Rate (including Freight & required insurance, applicable duties & Taxes excluding GST) To be entered in Figures by the Bidder	Rate of GST (applicable on column 5) To be entered by Bidder (%)	Unit GST rate on supply cost per SPV System col (5) x col (6)	Per SPV system unit Rate for Design, Survey, Installation, Testing, Commissioning & 5 years Comprehensive Maintenance including applicable duties & Taxes excluding GST To be entered by the Bidder	Rate of GST (applicable on column 8) To be entered by Bidder (%)	Unit GST rate on installation cost per SPV System col (8) x col (9)	Total unit Rate per system (excluding GST) col (11) = col (5) + col (8)	Total unit GST Rate per system (including GST) col (12) = col (7) + col (10)	Total Unit Rate per system (including GST) col (13) = col (11) + col (12)	TOTAL AMOUNT (excluding GST) col (14) = (3) x (11)	TOTAL AMOUNT (including GST) col (15) = (3) x (13)	TOTAL AMOUNT In Words
1	2	3	4	5	6	7	8	9	10	11	12	13	14	15	16
Capacity of SPV System															
101	4.5 kWp	102	Nos			0.00			0.00	0.00	0.00	0.00	0.00	0.00	INR Zero Only
102	7.5 kWp	851	Nos			0.00			0.00	0.00	0.00	0.00	0.00	0.00	INR Zero Only
103	11.25 kWp	45	Nos			0.00			0.00	0.00	0.00	0.00	0.00	0.00	INR Zero Only
Total in Figures													0.00	0.00	INR Zero Only
Quoted Rate in Words															
INR Zero Only															

- Note:
- (i) The offer is valid for six months from date of opening of tender.
 - (ii) L-1 will be decided on the basis of sum of column (15) of above table only.
 - (iv) **This format is for information only. All bidders are advised to submit their price offers online in MS Excel File cover-III only.**

SECTION - K: FORMATS APPLICABLE

K.1. Performance Security

(On Non judicial Stamp of worth 0.25% of BG Value (maximum stamp duty of Rs. 25000/-))

Bank Guarantee No.

Date.....

Contract No.....

.....[Name of Contract].....

To

Concerned Discom Official

Concerned Discom & Address

Dear Ladies and/or Gentlemen,

We refer to the Letter of Intent ("LOI") <Insert LOI No:>, issued on <Insert Date of Issue of LOI by Discom.....> by Jaipur Vidyut Vitran Nigam Limited (hereinafter referred to as "JVVNL"), having its Registered Office at Vidyut Bhawan, near Vidhana sabha, Jyoti Nagar, Jaipur-302001 (Rajasthan), to M/s (*Name of Contractor*), having its Principal place of business at(*Address of Contractor*) and Registered Office at(*Registered address of Contractor*) ("the Contractor") concerning ***“Work of Design, survey, supply, installation, testing, commissioning & 5 years comprehensive maintenance of distributed grid connected solar PV systems for solarization of grid connected agriculture consumers under “KUSUM Scheme – Component C” in Jaipur Discoms (JVVNL under NIT No: JVVNL/KUSUM-C/GRID-SPV/TN-04/2020 (Lot 1 to 10) on turnkey basis, and the LOI having been accepted by the selected Contractor vide <.....Insert Letter No....>, resulting in Letter of Award to be issued and Contract Agreement to be entered into. [Applicable for Bank Guarantees issued by Contractor/Associate for those Contracts awarded to them]***

Or

(Select Option accordingly as applicable)

We refer to the Letter of Intent ("LOI") <Insert LOI No:>, issued on <Insert Date of Issue of LOI by Discom.....> by Vidyut Vitran Nigam Limited (hereinafter referred to as "JVVNL"), having its Registered Office at Vidyut Bhawan, Near Vidhan Sabha ,Jyoti Nagar, Jaipur-302001 (Rajasthan), to M/s (*Name of Contractor*), having its

Principal place of business at(*Address of Contractor*) and Registered Office at(*Registered address of Contractor*) ("the Contractor") and M/s (*Name of Associate*), having its Principal place of business at(*Address of Associate*) and Registered Office at(*Registered address of Associate*), the Associate of the Contractor, ***“Work of Design, survey, supply, installation, testing, commissioning & 5 years comprehensive maintenance of distributed grid connected solar PV systems for solarization of grid connected agriculture consumers under “KUSUM Scheme – Component C” in Jaipur Discoms on under NIT No: JVVNL/KUSUM-C/GRID-SPV/TN-04/2020 (Lot 1 to 10)*** on turnkey basis, and the LOI having been accepted by the selected Contractor vide <.....Insert Letter No....>, resulting in Letter of Award to be issued and Contract Agreement to be entered into. [*Applicable for Bank Guarantees to be issued by Contractor against those Contracts awarded to their Associate*]

By this letter we, the undersigned,(*insert name & address of the issuing bank*), a Bank (which expression shall include its successors, administrators, executors and assigns) organized under the laws of and having its Registered/Head Office at(*insert address of registered office of the bank*)..... do hereby irrevocably guarantee payment to the Discom up to i.e., Ten percent (10%) of the Contract Price until ninety (90) days beyond the 60 months from the date of successful installation of last system i.e., upto and inclusive of (*dd/mm/yy*).

We undertake to make payment under this Letter of Guarantee upon receipt by us of your first written demand signed by the Discom duly authorized officer or the authorized officer of **Discom** declaring the Contractor to be in default under the Contract and without civil or argument any sum or sums within the above named limits, without your need to prove or show grounds or reasons for your demand and without the right of the Contractor to dispute or question such demand.

Our liability under this Letter of Guarantee shall be to pay to the Discom whichever is the lesser of the sum so requested or the amount then guaranteed hereunder in respect of any demand duly made hereunder prior to expiry of the Letter of Guarantee, without being entitled to inquire whether or not this payment is lawfully demanded.

This letter of Guarantee shall remain in full force and shall be valid from the date of issue until ninety (90) days beyond the 60 months from the date of successful installation of last system i.e. upto and inclusive of (*dd/mm/yy*) and shall be extended from time to time for such period (not exceeding one year), as per the terms & conditions of Tender Document.

Except for the documents herein specified, no other documents or other action shall be required, notwithstanding any applicable law or regulation.

Our liability under this Letter of Guarantee shall become null and void immediately upon its expiry, whether it is returned or not, and no claim may be made hereunder after such expiry or after the aggregate of the sums paid by us to the Discom shall equal the sums guaranteed hereunder, whichever is the earlier.

All notices to be given under shall be given by registered (airmail) posts to the addressee at the address herein set out or as otherwise advised by and between the parties hereto.

All disputes arising under the said Guarantee between the Bank and the Discom or between the contractor and the Discom pertaining to the Guarantee shall be subject to the jurisdiction of courts only at (Jaipur) in Rajasthan alone.

We hereby agree that any part of the Contract may be amended, renewed, extended, modified, compromised, released or discharged by mutual agreement between you and the Contractor, and this security may be exchanged or surrendered without in any way impairing or affecting our liabilities hereunder without notices to us and without the necessity for any additional endorsement, consent or guarantee by us, provided, however, that the sum guaranteed shall not be increased or decreased.

No action, event or condition which by any applicable law shall operate to discharge us from liability hereunder shall have any effect and we hereby waive any right we may have to apply such law so that in all respects our liability hereunder shall be irrevocable and, except as stated herein, unconditional in all respects.

For and on behalf of the Bank

[Signature of the authorised signatory(ies)]

Signature_____

Name_____

Designation_____

POA Number_____

Contact Number(s): Tel._____ Mobile_____

Fax Number_____

email _____

Common Seal of the Bank_____

Witness:

Signature_____

Name_____

Address_____

Contact Number(s): Tel._____ Mobile_____

email _____

Note:

1. For the purpose of executing the Bank Guarantee, the non-judicial stamp papers of appropriate value shall be purchased in the name of Bank who issues the 'Bank Guarantee'.
2. The Bank Guarantee shall be signed on all the pages by the Bank Authorities indicating their POA nos. and shall invariably be witnessed.
3. The Bank Guarantee shall be in accordance with the proforma as provided. However, in case the issuing bank insists for additional paragraph for limitation of liability, the following may be added at the end of the proforma of the Bank Guarantee [*i.e., end paragraph of the Bank Guarantee preceding the signature(s) of the issuing authority(ies) of the Bank Guarantee*]:

Quote

“Notwithstanding anything contained herein:

1. Our liability under this Bank Guarantee shall not exceed _____ (*value in figures*)_____ [*_____ (value in words)_____*].
2. This Bank Guarantee shall be valid upto _____ (*validity date*)_____.
3. We are liable to pay the guaranteed amount or any part thereof under this Bank Guarantee only & only if we receive a written claim or demand on or before _____ (*validity date*) _____.”

Unquote

K.2. Bank Guarantee (Mobilization Advance)

(On Non judicial Stamp of worth 0.25% of BG Value (maximum stamp duty of Rs. 25000/-)

Bank Guarantee No.

Date.....

Contract No.....

.....[Name of Contract].....

To

Concerned Discom Official

Concerned Discom & Address

Dear Ladies and/or Gentlemen,

We refer to the Letter of Intent ("LOI") <Insert LOI No:>, issued on <Insert Date of Issue of LOI by Discom.....> by Jaipur Vidyut Vitran Nigam Limited (hereinafter referred to as "JVVN"), having its Registered Office at Vidyut Bhawan, near Vidhana sabha, Jyoti Nagar, Jaipur-302001 (Rajasthan), to M/s (*Name of Contractor*), having its Principal place of business at(*Address of Contractor*) and Registered Office at(*Registered address of Contractor*) ("the Contractor") concerning ***“Work of Design, survey, supply, installation, testing, commissioning & 5 years comprehensive maintenance of distributed grid connected solar PV systems for solarization of grid connected agriculture consumers under “KUSUM Scheme – Component C” in Jaipur Discoms (JVVN under NIT No: JVVN/KUSUM-C/GRID-SPV/TN-04/2020 (Lot 1 to 10) on turnkey basis, and the LOI having been accepted by the selected Contractor vide <.....Insert Letter No....>, resulting in Letter of Award to be issued and Contract Agreement to be entered into. [Applicable for Bank Guarantees issued by Contractor/Associate for those Contracts awarded to them]***

Or

(Select Option accordingly as applicable)

We refer to the Letter of Intent ("LOI") <Insert LOI No:>, issued on <Insert Date of Issue of LOI by Discom.....> by Vidyut Vitran Nigam Limited (hereinafter referred to as "JVVN"), having its Registered Office at Vidyut Bhawan, Near Vidhan Sabha ,Jyoti Nagar, Jaipur-302001 (Rajasthan), to M/s (*Name of Contractor*), having its Principal place of business at(*Address of Contractor*) and Registered Office at(*Registered address of Contractor*)

..... ("the Contractor") and M/s
(Name of Associate), having its Principal place of business at(Address of Associate) and Registered Office at(Registered address of Associate), the Associate of the Contractor, **“Work of Design, survey, supply, installation, testing, commissioning & 5 years comprehensive maintenance of distributed grid connected solar PV systems for solarization of grid connected agriculture consumers under “KUSUM Scheme – Component C” in Jaipur Discoms on under NIT No: JVVNL/KUSUM-C/GRID-SPV/TN-04/2020 (Lot 1 to 10) on turnkey basis, and the LOI having been accepted by the selected Contractor vide <.....Insert Letter No....>, resulting in Letter of Award to be issued and Contract Agreement to be entered into. [Applicable for Bank Guarantees to be issued by Contractor against those Contracts awarded to their Associate]**

By this letter we, the undersigned,(insert name & address of the issuing bank), a Bank (which expression shall include its successors, administrators, executors and assigns) organized under the laws of and having its Registered/Head Office at(insert address of registered office of the bank)..... do hereby irrevocably guarantee payment to the Discom up to i.e., Ten percent (10%) of the Supply value of the total Contract Price until ninety (90) days after the scheduled month of supply of materials i.e., upto and inclusive of (dd/mm/yy).

We undertake to make payment under this Letter of Guarantee upon receipt by us of your first written demand signed by the Discom duly authorized officer or the authorized officer of **Discom** declaring the Contractor to be in default under the Contract and without civil or argument any sum or sums within the above named limits, without your need to prove or show grounds or reasons for your demand and without the right of the Contractor to dispute or question such demand.

Our liability under this Letter of Guarantee shall be to pay to the Discom whichever is the lesser of the sum so requested or the amount then guaranteed hereunder in respect of any demand duly made hereunder prior to expiry of the Letter of Guarantee, without being entitled to inquire whether or not this payment is lawfully demanded.

This letter of Guarantee shall remain in full force and shall be valid from the date of issue until ninety (90) days after the scheduled month of supply of materials i.e. upto and inclusive of (dd/mm/yy) and shall be extended from time to time for such period (not exceeding one year), as per the terms & conditions of Tender Document.

Except for the documents herein specified, no other documents or other action shall be required, notwithstanding any applicable law or regulation.

Our liability under this Letter of Guarantee shall become null and void immediately upon its expiry, whether it is returned or not, and no claim may be made hereunder after such expiry or after the aggregate of the sums paid by us to the Discom shall equal the sums guaranteed hereunder, whichever is the earlier.

All notices to be given under shall be given by registered (airmail) posts to the addressee at the address herein set out or as otherwise advised by and between the parties hereto.

All disputes arising under the said Guarantee between the Bank and the Discom or between the contractor and the Discom pertaining to the Guarantee shall be subject to the jurisdiction of courts only at (Jaipur) in Rajasthan alone.

We hereby agree that any part of the Contract may be amended, renewed, extended, modified, compromised, released or discharged by mutual agreement between you and the Contractor, and this security may be exchanged or surrendered without in any way impairing or affecting our liabilities hereunder without notices to us and without the necessity for any additional endorsement, consent or guarantee by us, provided, however, that the sum guaranteed shall not be increased or decreased.

No action, event or condition which by any applicable law shall operate to discharge us from liability hereunder shall have any effect and we hereby waive any right we may have to apply such law so that in all respects our liability hereunder shall be irrevocable and, except as stated herein, unconditional in all respects.

For and on behalf of the Bank

[*Signature of the authorised signatory(ies)*]

Signature_____

Name_____

Designation_____

POA Number_____

Contact Number(s): Tel._____Mobile_____

Fax Number_____

email _____

Common Seal of the Bank_____

Witness:

Signature_____

Name_____

Address_____

Contact Number(s): Tel._____Mobile_____

email _____

Note:

1. For the purpose of executing the Bank Guarantee, the non-judicial stamp papers of appropriate value shall be purchased in the name of Bank who issues the 'Bank Guarantee'.
2. The Bank Guarantee shall be signed on all the pages by the Bank Authorities indicating their POA nos. and shall invariably be witnessed.
3. The Bank Guarantee shall be in accordance with the proforma as provided. However, in case the issuing bank insists for additional paragraph for limitation of liability, the following may be added at the end of the proforma of the Bank Guarantee [*i.e., end paragraph of the Bank Guarantee preceding the signature(s) of the issuing authority(ies) of the Bank Guarantee*]:

Quote

“Notwithstanding anything contained herein:

1. Our liability under this Bank Guarantee shall not exceed _____ (*value in figures*)_____ [*_____ (value in words)_____*].
2. This Bank Guarantee shall be valid upto _____ (*validity date*)_____.
3. We are liable to pay the guaranteed amount or any part thereof under this Bank Guarantee only & only if we receive a written claim or demand on or before _____ (*validity date*) _____.”

Unquote

K.3. Format of Agreement between Beneficiary (Agriculture Consumer and Contractor for maintenance of SPV system under Scheme)

Format of Agreement between beneficiary and supplier for maintenance of SPV for solarization of grid connected AG pump set under KUSUM Scheme-Component C.

अनुबन्ध पत्र

(अजमेर/जोधपुर/जयपुर विद्युत वितरण निगम लिमिटेड के ग्रिड कनेक्टेड कृषि पम्पसेट के सौलराइजेशन हेतु "कुसुम योजना-Component C" के अन्तर्गत एस्.पी.वी. उपकरण सप्लायर व लामाणित के मध्य स्थापना व संवारण के लिए किये जाने वाला अनुबन्ध पत्र)

आज दिनांकको मै0.....(सप्लायर) व श्रीपुत्र श्री.....
.....नियासी.....जिला.....किये जाने वाले कि.पॉट एस्.पी.वी.
सौर उपकरण की स्थापना के संबंध में यह अनुबन्ध निम्न शर्तों के साथ किया जा रहा है:-

यह उपकरण अजमेर/जोधपुर/जयपुर विद्युत वितरण निगम लिमिटेड द्वारा संचालित कुसुम योजना 2019-20 के तहत लगाया जा रहा है/गया है।
सामान्य शर्तें व विनिम्न पक्षों के दायित्व:-

(1) सप्लायर के दायित्व:-

1. प्रत्येक लामार्थी राजस्थान राज्य का नियासी होना चाहिए।
2. सप्लायर द्वारा कार्यादेश के संबंधित संलग्नक के अनुसार पूर्ण सिस्टम की स्थापना की जायेगी।
3. (i) अजमेर/जोधपुर/जयपुर विद्युत वितरण निगम लिमिटेड शर्तानुसार उपकरण स्थापना परचात् लामार्थी को संभालने (Handing Over) के दिन उपकरण पूर्णतया कार्यशील होगा व कोई हिस्ता दूटा-कूटा या बेकार नहीं होगा।
(ii) सप्लायर लामार्थी को देय नागरी लिपि में सिस्टम की पूर्ण जानकारी एवं ब्या करें ब्या ना करें तथा संचालन मैन्युअल उपलब्ध करवाएंगे।
4. इस उपकरण में जो सब सुविधायें/पार्ट्स होंगे जो कार्यादेश के संबंधित संलग्नक में दिये गये हैं।
5. उपकरण लगाने से पांच वर्ष के भीतर ही सिस्टम खराब होने पर सप्लायर द्वारा उपकरण को ठीक कर क्रियाशील करना होगा। जिसके लिए यदि नया उपकरण लगाना पड़े तो भी सप्लायर को लगाकर उपकरण क्रियाशील करना होगा।
6. सप्लायर के कर्मचारी लामार्थी को उपकरण के रखरखाव के सम्बन्ध में पूर्ण जानकारी एवं प्रशिक्षण देंगे।
7. सप्लायर अपने कर्मचारियों/एजेन्ट को इस कार्य के लिए तहसील/जिला मुख्यालय (or at proper place) पर नियुक्त रखेंगे, जिससे लामार्थी इनसे सीधे सम्पर्क रख सकेंगे।
8. सप्लायर के कर्मचारियों/एजेन्ट को पहचान पत्र देकर रखेंगे जो दिखाने पर ही लामाणित उनको नियास स्थान पर प्रवेश करने देगा।
9. इस संबंध में अजमेर/जोधपुर/जयपुर विद्युत वितरण निगम लिमिटेड के प्रबन्ध निदेशक का फैसला अंतिम व माध्य होगा।

(2) लामाणित के दायित्व:-

1. लामाणित अपने खेत पर लगे ग्रिड कनेक्टेड एस्.पी.वी. द्वारा स्वीकृत भार के कृषि पम्प सेट को चलाने के उपयोग में ही लेगा। लामार्थी अतिरिक्त क्षमता के कृषि पम्प सेट अथवा अन्य किसी भी उपयोग में नहीं लेगा।
2. यदि लामार्थी उपकरण के साथ निर्देशों के विपरित किसी प्रकार की अयाचित छेद-छाड जैसे स्थानांतरण, दूसरे काम में लेना सिद्ध होने पर, उपकरण की पांच वर्ष की गारण्टी स्वतः ही समाप्त मानी जाएगी।
3. लामाणित सिस्टम खराब होने पर सप्लायर के कर्मचारियों को सूचित करेंगे न कि स्वयं सिस्टम को ठीक करने का प्रयास करेंगे।
4. सप्लायर द्वारा रख-रखाव न करने पर नोटल अधिकारी, अजमेर/जोधपुर/जयपुर विद्युत वितरण निगम लिमिटेड को तत्काल सूचित करेंगे।
5. लामाणित लगाये गये उपकरण की सुरक्षा के लिए पूर्णतया जिम्मेदार होगा व चोरी होने पर पुलिस में तत्काल एफआईआर दर्ज करा के निगम को सूचित करेगा।

सप्लायर के अधिकृत प्रतिनिधि
नाम.....
पद.....
पिनाग.....

लानाम्पित के हस्ताक्षर
लानाम्पित श्री.....
पुत्र श्री.....
बया अनुजाति/जनजाति के
सदस्य है.....
के नम्बर
ग्राम.....
ग्राम पं०.....
पंचायत समिति.....
जिला

Mobile Number of beneficiary:

प्रमाण-पत्र

प्रमाणित किया जाता है कि श्री..... पुत्र श्री..... निवासी.....
जिला..... के यहाँ मैसर्स..... द्वारा कि.घॉट एस.पी.पी. मोड्यूल क्षमता के संयंत्र की
स्थापना "कुसुम योजना"के अन्तर्गत की गई है, यह उपकरण लानार्थी द्वारा निर्देशित उपयोग में कार्य लिया जायेगा। यह
अनुबंध पत्र लानार्थी एवं सप्लायर/सप्लायर एजेंट के मध्य दिनांक.....को निम्न हस्ताक्षरकर्ता की उपस्थिति में किया
गया ।

हस्ताक्षर मय सील
कनिष्ठ अनियन्ता/सहायक अनियन्ता (पयस)
.....
डिस्कॉम,

उपकरण स्थापना एवं अनुबंध पत्र प्रमाणित

नोडल अधिकारी/इंजीनियर ईन्चार्ज
अजमेर विद्युत वितरण निगम लिमिटेड,

K.4. Format for SPV Installation Certificate from Beneficiary Officer, Discom.

Format for system installation verification from beneficiary, Concerned O&M Office & Project Officer, AVVNL / JDVVNL / JVVNL

उपकरण स्थापना प्रमाण-पत्र

प्रमाणित किया जाता है कि लाभार्थी श्रीपुत्र श्रीनियाली
.....जिला.....के निवास पर मैसर्स
.....के अधिकृत सप्लायर द्वारा "कुसुम योजना"के अन्तर्गत एक एस.पी.पी. उपकरण (.....
KWP) की स्थापना दिनांकको की गई है जो मेरे द्वारा देख ली गई है, यह सुचारू रूप से
कार्य कर रही है। फर्म द्वारा लाभार्थी को एक देय नागरी लिपी का मैनुअल, अनुबन्ध पत्र एवं सेवा केन्द्रों तथा
सम्पर्क करने वाली अधिकारीगण की सूची उपलब्ध करा दी गई है।

हस्ताक्षर लाभार्थी

हस्ताक्षर मय सील
कनिष्ठ अभियन्ता / सहायक अभियन्ता (पवर)
.....डिस्कॉम,

अजमेर विद्युत वितरण निगम लिमिटेड के नोडल अधिकारी की रिपोर्ट

मैंनोडल अधिकारी, अजमेर विद्युत वितरण निगम लिमिटेड.....उपरोक्त
घरिंत एस.पी.पी. उपकरण की स्थापना बाबत लाभार्थी के संयंत्र का व्यक्तिशः निरीक्षण उपरान्त प्रमाणित करता
हूँ कि :-

- (i) एस.पी.पी. उपकरण सही प्रकार के टेण्डर में घरिंत स्पेसिफिकेशन एवं निधिदा शर्तों के अनुसार
स्थापित किया गया है।
- (ii) लाभार्थी के ग्रिड कनेक्टेड कृषि पम्प सेट पर स्थापित उपकरण (..... KWP) सही हालत में कार्यरत है।

हस्ताक्षर नोडल अधिकारी
मय सील

नोट: लाभार्थी के ग्रिड कनेक्टेड कृषि पम्प सेट पर स्थापित उपकरण निधिदा शर्तों के अनुसार जाँच उपरान्त
हस्ताक्षर कर इस प्रमाण पत्र को साथ संलग्न की जाये।।

K.5. Format for Name Plate (SECTION - I: 22.1.3)

“सौर ग्रिड द्वारा जुड़े हुए कृषि उपभोक्ता पम्प सेट”		
1	लाभान्वित कृषि उपभोक्ता का नाम	
2	के, नम्बर	
3	लाभान्वित कृषि उपभोक्ता की श्रेणी	
4	गांव का नाम	
5	तहसील / जिला	
6	उपखण्ड	
7	वर्तमान स्वीकृत भार (HP)	
8	ग्रिड से जुड़े हुए सौर पी.टी. की क्षमता (KWP)	
9	सौर एस.पी.टी. ठेकेदार का नाम	
10	ठेकेदार के सर्विस सेण्टर मय कार्यालय का पता त सम्पर्क नम्बर	
11	सर्विस सेण्टर का सम्पर्क नम्बर	
12	ठेकेदार / सर्विस सेण्टर की ई-मेल आईडी	
13	सौर स्टेशन की स्थापना की तिथि	

K.6. Format for Undertaking to be submitted by a firm for faithfully carrying out the assigned work

In consideration of the(Name and Address of Discom (hereinafter called as “Discom”) having authorised us
(Name of the Contractor), office at
(hereinafter called the Contractor) for the work of design, supply, installation, testing, commissioning & 5 years comprehensive maintenance of distributed grid connected solar PV systems for solarization of grid connected agriculture consumers under “KUSUM Scheme – Component C” in Jaipur DISCOM through NIT No. JVVNL/KUSUM-C/GRID-SPV/TN-04/2020 (Lot 1 to 10) (hereinafter referred as Scope of Work) and on successful completion of the Scope of Work and Discom having agreed to disburse the financial assistance due under the programme, Contractor does hereby undertake to carry out the Scope of Work as per terms and condition of the Tender document and Work Order issued to us by Discom.

We do hereby further undertake that in case we are unable to carryout out duties as undertaken above, Discom would have the right to forfeit the entire Performance Security amount deposited by us for the said work with them.

We at (Name of the Contractor) further agree that the undertaking herein contained shall remain in full force and effect for the period of the year from the date of this undertaking or for such period for which this undertaking is executed.

Dated this day of 2019.

Signature for and on behalf of Contractor

Name of Authorized Signatory

Name of Contractor

Seal of Contractor

Date

Place

K.7. Installation Certificate

GST No:	M/s.....	Phone No:
	Address:	Fax No:
	(Name and Address of Contractor.....)	E-mail

INSTALLATION CERTIFICATE

Date of Installation:

Payment claim Note No:

S. No.	Details	
1.	Name of Agriculture Consumer (Beneficiary)	
2.	K.No.	
3.	Agriculture Consumer Category	
4.	Sanctioned Load	
5.	Mobile No:	
6.	Aadhar No:	
7.	Father/ Husband Name	
8.	Address	
9.	Dhani Name	
10.	Name of Village	
11.	Name of Gram Panchayat	
12.	Name of Panchayat Samiti	
13.	Name of District	
14.	Name of Rajasthan State Constituency	
15.	Name of Parliamentary Constituency	
16.	Caste Group: (Gen/SC/ST/OBC/Other....specify)	
17.	Site Co-ordinate (Longitude / Latitude)	

Certified thatKW PV Capacity Grid-Connected SPV system in reference to (.....Name of Discom) Work Order No:..... Dated:..... has been installed and commissioned at the place of Agriculture Consumer mentioned above and the system has been handed over to the Agriculture Consumer in good working condition.

Revised Tender document for solarization of grid connected agriculture consumers

The details of material supplied and installed are as under :

S.No.	Item:	Quantity	Make	Serial Numbers.
1.				
2.				

Signature of Agriculture Consumer

Signature of Nodal Officer

Name of Agriculture Consumer

Name of Nodal Officer

Date

Name of Discom

Place

Seal of Discom

Date

Place

Signature of and on behalf of Contractor

Signature of AEN (O&M)

Name of Authorized Signatory

Name of AEN (O&M)

Name of Contractor

Name of Discom

Seal of Contractor

Date

Place

Seal of Discom

Date

Place

Signature of AEN (M&P)

Name of AEN (M&P)

Name of Discom

Seal of Discom

Date

Place

K.8. Payment Claim Note

Payment Claim Note No:

Date:

To,

Discom Designated Officer:

Name of Discom:

Address:

Please arrange to release payment to M/s -----(Name of Contractor) against supply, installation and commissioning of SPV Systems in reference to(Name of Discom), Work order No. -----dated----- under “KUSUM – Component C: 2019-20” in -----circle for the ----- 11kV feeder of ----- 33/11kV substation.

Details of solarized consumers are as under:

S. No.	Name of Agriculture Consumer :	K. No.:	Address:	District	Installation Note Ref No:	Invoice No. & Date	Payment claim amount
						Total	

Signature for and on behalf of Contractor

Name of Authorized Signatory

Name of Contractor

Seal of Contractor

Date

Place

K.9. Contract Completion Certificate by Discom

Certificate from Project Officer,Name of Discom

Following are certified in reference to (Name of Discom.....) Work Order No.....Date..... referred above for supply, installation & commissioning of ---- Nos. Grid-Connected SPV systems:

1. A contract (including maintenance agreement) as per the format at SECTION - K: (Format K.14) of Tender Document has been executed with the beneficiary.
2. The material has been supplied in good condition as per technical specification of tender document/work order.
3. The work has been completed within stipulated period / with a delay of ----- days.
4. Instruction Manual, Guarantee Card & Money Receipt has been provided to beneficiaries.
5. System has been installed at beneficiary site and working satisfactory.
6. Village wise details of installation is as per above statement.
7. The work as envisaged under the Contract to complete the CMC for the required period has been completed.

Verified for payment of Rs. -----/- (Rs.-----) as per terms and condition of said Tender Document and Work Order.

Signature for and on behalf of Discom

Name of Nodal Officer

Name of Discom

Seal of Discom

Date

Place

K.10. Operational Acceptance Certificate

(Format to be provided after award of Contract)

K.11. Taking Over Certificate

(Format to be provided after award of Contract)

K.12. Guarantee Card

Format for guarantee card to be supplied with each grid connected solar PV system

1. Name & Address of the supplier of the System:
2. Name & Address of Discom:
3. Date of supply of the system :
4. Details of PV Module (s) supplied in the System Make (Name of the Contractor):
 1. Model Serial No(s)
 2. Wattage of the PV Module (s) under STC Guarantee valid up to
5. Details of Electronics & other BOS items:
 3. System Make (Name of the Contractor) Model
 4. Serial No(s) Guarantee valid up to
5. Designation & Address of the person to be Contacted for claiming Guarantee obligations

(Signature)

Name & Designation

Name & Address of the Agency

(SEAL)

Place & Date:

(During the guarantee period **Discom** reserves the right to cross check the performance of the systems with the minimum performance levels specified in the Tender Document specifications).

K.13. Maintenance & Servicing Report

QUARTERLY MAINTENANCE & SERVICING REPORT

1. DETAILS OF SOLAR PHOTOVOLTAIC SYSTEM INSTALLED

- a) Supplied by:
- b) Date of installation:
- c) Servicing period: From to

2. USER PROFILE

1. Name and address of User:

3. TECHNICAL DETAILS

1. Module Capacity, make and serial numbers:
2. Inverter Capacity, make and serial no.

4. CHECK OF THE PRODUCT

1. Correct inclination and orientation of SPV panel:
2. Cleaning of dust from SPV panel:
3. Interconnection of modules, charge controller etc.:
4. Fuse of charge controller:
5. Working of inverter

5. DIFFICULTIES IN OPERATION/ PROBLEM FACED BY USER:

6. DIAGNOSIS DETAILS/ REPAIR ACTION:

7. DATE ON WHICH SYSTEM WAS LAST ATTENDED:

8. IT IS MANDATORY TO SUBMIT INSTALLATION WISE QUARTERLY ENERGY

9. GENERATION DATA TO RESPECTIVE PGVCL OFFICE.

10. REMARKS:

Beneficiary Name & Signature

Contractor's Name & Signature

Date: (with rubber stamp)

Signature for and on behalf of Discom

Name of Nodal Officer (DISCOM Name)

Date and Place

K.14. Contract Agreement for Award of Work

(To be executed on Non-judicial Stamp paper of Rajasthan State of worth 0.25% of Contract Value)

CONTRACT AGREEMENT

THIS AGREEMENT made on this day of Two thousand **BETWEEN**

{In case of single bidder}

- (1) (Name of the Successful Bidder), having Registered Office at and represented by(Name and designation of the Authorized Officer (herein after called “**The Contractor**”, which expression where the context so requires or admits shall include his legal heir, administrators, executors, assignees and legal representatives) of the **ONE PART**.

{In case of Joint Venture}

- (1) Joint Venture (JV) of M/s..... (Name of Lead Partner)..... (the Lead Partner of JV), a company incorporated under the laws of Companies Act 1956 and having its Principal place of business at(Address of Lead Partner) and Registered Office at(Registered address of Lead Partner) and M/s (Name of Other Partner)..... (the Partner of JV), a company incorporated under the laws of Companies Act 1956/2013 (with amendment from time to time) and having its Principal place of business at(Address of Other Partner)..... (hereinafter called "the Contractor" and also referred to as “Joint Venture”/the ‘JV’”)

AND

- (2) (Name of respective Discom), having Registered Office at and represented by (Name and designation of the Authorized Officer (here in after called “**Discom**”, which expression where the context so requires or admits shall include his administrators, executors, authorised person, assignees and legal representatives) of the **OTHER PART**.

WHEREAS, the Contractor willingly submitted Bids for Tender Document issued vide NIT No. JVVNL/KUSUM-C/GRID-SPV/TN-04/2020 (Lot 1 to 10) of the Jaipur Vidyut Vitran Nigam Limited for the work of design, survey, supply, installation, testing, commissioning & 5 years comprehensive maintenance of distributed grid connected solar PV systems for solarization of grid connected agriculture consumers under “KUSUM Scheme – Component C” in Jaipur DISCOM.

The Project of the work of design, survey, supply, installation, testing, commissioning & 5 years comprehensive maintenance of distributed grid connected solar PV systems for solarization of grid connected agriculture consumers under “KUSUM Scheme – Component C” in Jaipur DISCOM as per Tender Document issued vide NIT No. JVVNL/KUSUM-C/GRID-SPV/TN-04/2020 (Lot 1 to 10) as specified and as per Scope of Work & detailed terms & conditions provided in the Tender Document accepted by Contractor and Work Order issued vide No.....dtd..... by the Discom at the accepted respective prices or rates mentioned against the said items / materials in the Work Order.

AND WHEREAS THE CONTRACTOR has accepted the Tender Document for the supply for the total sum of Rs. _____ (Rupees _____ only) *including / excluding taxes upon the terms and subject to the conditions herein mentioned in the agreement.

AND WHEREAS, a list is made out in the “**SCHEDULE**” hereunder written and all of which said documents of the Schedule are deemed to form part of this agreement and included in the expression “**the Scope of Work**” wherever herein used, upon the terms and subject to the conditions hereinafter mentioned.

NOW THIS AGREEMENT WITNESSES AS UNDER AND IT IS HEREBY AGREED AND DECLARED THAT:-

1. The Contractor has accepted the Terms and Conditions set out in the Tender Document issued vide NIT No. JVVNL/KUSUM-C/GRID-SPV/TN-04/2020 (Lot 1 to 10) dtd. as well as in the form of
 - a. Acceptance of Tender Document and Letter of Acceptance of Tender Document No. dtd. which will hold good & valid during the period of this Agreement.
 - b. Acceptance of Letter of Intent and Letter of Acceptance of Letter of Intent No. dtd. which will hold good & valid during the period of this Agreement.
 - c. Acceptance of Work Order and Letter of Acceptance of Work Order No. dtd. which will hold good & valid during the period of this Agreement.
2. The Contractor shall do and perform for all Scope of Work mentioned and described in this agreement or which are implied therein or therefrom respectively or are reasonably necessary for the in-time and in manner supplies as mentioned and subject to the general / commercial terms & conditions and stipulations contained in this agreement.
3. In consideration of the due provision, executions, completion of the Scope of Work, as agreed to by the Contractor as aforesaid, the Discom hereby agrees to pay all the sums of money as and when they become due and payable to the Contractor under the

provisions of the agreement and such payment to be made at such times and in such manner as provided in the agreement.

Contract Price (Reference Clause E.9 of tender document)

Discom hereby agrees to pay to the Contractor the Contract Price in consideration of the performance by the Contractor of its obligations under Scope of Work pursuant to Tender Document. The Contract Price shall be the aggregate of..... (Amount in words)..... (..... (Amount in figures)), or such other sums as may be determined in accordance with the terms and conditions of the Contract.

The break-up of the Contract price is as under:

Sl. No.	Price Component	Quantity	Amount
1.			
2.			
Total for Contract Price			

The payment terms & conditions are detailed in the Work Order.

4. In respect of the said Tender Document as per the terms & conditions of this Agreement, the Contractor has provided valid Bank Guarantee of Rs. (Rupeesonly) with the Discom towards Performance Security as per the terms & conditions of Tender Document.
5. Upon breach by the Contractor of any of the conditions of this Agreement, the Discom may give a notice in writing to rescind, determine and put to an end to the Contract without prejudice to the right of the Discom to claim damages for antecedent breaches thereof on the part of the Contractor and also to claim reasonable compensation / risk & cost purchase for the loss occasioned by the Discom due to failure of the Contractor to fulfill the terms & conditions of Tender Document as certified in writing by the Discom for which Certificate shall be conclusive evidence of the amount of such compensation payable by the Contractor to the Discom.
6. The Discom shall not be bound to take the whole or any part of the ordered quantity herein or therein mentioned in the Work Order/ Tender Document and may cancel the contract at any time after giving ONE MONTH'S NOTICE IN WRITING without compensating the Contractor.
7. This Contract shall remain in force till the expiry of satisfactory performance of the Contractor as per the Scope of Work required pursuant to the Tender Document during Guarantee period including for the quantity mentioned in the repeat order, if any as per the terms & conditions of the Work Order/ Tender Document.
8. Any Notice in connection with the Scope of Work including the Notice for termination may be given by the Discom or any Authorized Officer of Discom for the said purpose as per the Commercial Terms & Conditions of the Work Order/ Tender Document.

9. If subject to the circumstances beyond control i.e. Force Majeure conditions, the Contractor fails to deliver the Scope of Work, the same shall be governed as per the Tender Document.
10. {Insert in case of JV}, Joint venture Partners including Lead Member declare and confirm that the Partners in Joint Venture shall jointly and severally be bound unto the Discom for the successful performance of the Contract and shall be fully responsible for the delivery of required Scope of Work pursuant to the Tender Conditions.
11. The agreed value, extent of supply, delivery dates, specifications, and other relevant matters may be altered by mutual agreement as per the policy of the Discom and if so altered shall not be deemed or construed to mean or apply to affect or alter other general / commercial terms & conditions of the Contract and the Contract so altered or revised shall be and shall always be deemed to have been adhered subject to and without prejudice to said stipulation. The following is the Schedule forming part of this agreement as provided herein above:

SCHEDULE

List of documents:

- 1.
- 2.
- 3.
- 4.
- 5.

Signed by for and
on behalf of the Discom

.....
Signature

.....
Title

in the presence of

(The Authorized Signatory on behalf of Contractor shall submit the Power of Attorney on behalf of Contractor (also in case of JV) as per applicable Laws.)

Signed by for and
on behalf of the Contractor

.....
Signature

.....
Title

in the presence of

SECTION - L: OTHER ANNEXURES

L.1. Queries to be raised by Bidder (On Letterhead of Entity submitting Pre-bid Queries)

In Response to NIT No:	JVVNL/KUSUM-C/GRID-SPV/TN-04/2020 (Lot 1 to 10)
------------------------	-------------------------------------------------

To

The Superintending Engineer (Regulation)

Jaipur Vidyut Vitran Nigam Limited (JVVNL)

Room No. 149, Old Power House Premises, Banipark, Jaipur-302016

Email- sermdf@jvvn.org

Sub: Queries for Tender for Work of Design, survey, supply, installation, testing, commissioning & 5 years comprehensive maintenance of distributed grid connected solar PV systems for solarization of grid connected agriculture consumers under “KUSUM Scheme – Component C” in Jaipur DISCOM under TN-04/2020 (Lot 1 to 10) .

Ref: NIT NO: JVVNL/KUSUM-C/GRID-SPV/TN-04/2020 (Lot 1 to 10) dated;

Dear Sir,

Please find below our queries for the said tender:

S.No.	Clause No.	Change suggested	Rationale behind the suggested change

Signature & Seal

Name of Authorized Signatory

Designation

Name of Entity

Date

Place

L.2. MNRE Specifications of Remote Monitoring System (RMS)

- L.2.1. State Implementing Agency (SIA) will have a common SWPS (Solar Water Pumping System) Management platform for monitoring of operation and performance of SWPS installed under PM KUSUM Scheme.
- L.2.2. Remote Monitoring System (RMS) of SWPS should have following minimum features or modules:
- a) Solar System Performance: DC Voltage, DC current, AC output Current, Power, Drive frequency, Energy, etc.
 - b) Pump Performance: Running Hours, Water Discharge (Output), etc.
 - c) RMS Performance: %Device Connectivity, %Data Availability, etc.
 - d) Geo Location: Real time latitude and longitude should be captured. This is required to ensure that system is not moved from its original location.
 - e) Events and Notifications: Faults related to Pump Operation, Solar generation, Controller/Drive faults like overload, dry run, short circuit, etc.
 - f) Consumer Management: Name, Agriculture details, Service No. Contact Details, etc.
 - g) Asset Management: Ratings, Serial Number, Make, Model Number of Pump, Panel and Controller, Geo Location, IMEI number (of communication module) and ICCID (of SIM).
 - h) Complaint and Ticket Management: Complaint management system is a part of centralized monitoring software platform – State Level Solar Energy Management Platform to be operated and maintained by the State implementing agency (SIA).
 - i) Consumer Mobile Application: Generation, Running Hours, Water Discharge, Complaint logging, etc.
- L.2.3. RMS provided by all bidder's should connect to State Level Solar Energy Data Management platform, which will have interface with National Level Solar Energy Data Management platform i.e. SIA will provide server infrastructure as well as software. SIA will maintain the same. All vendors should provide SIM card of suitable ISP having maximum Signal Strength in the respective location of SWPS and ensure connectivity as well as pushing of data to centralized platform as mentioned in specifications.
- L.2.4. Communication Architecture should be as per following:
- a) Communication Connectivity:
 - i. Pump Controller Connectivity: Communication between RMS and Pump Controller should be on UART/RS485 MODBUS RTU protocol to ensure interoperability irrespective of make and manufacturer
 - ii. Remote Connectivity: RMS of SWPS should be using GSM/GPRS/2G/3G/4G cellular connectivity
 - iii. Local Connectivity: Ethernet/Bluetooth/Wi-Fi connectivity to configure parameters, notifications, communication interval, set points etc. or to retrieve locally stored data.
 - iv. Sensor Connectivity: RMS should have provision for at least two Analog/Digital inputs with 0.1% accuracy to address the requirement of local sensors connectivity if required by SIA/Consumer for applications such as irradiation, flow meter for water discharge, moisture sensor for micro irrigation, etc. Analog/digital sensor inputs will be required for integration of

flow meter for water discharge, moisture sensor for micro irrigation, level sensor for overhead tank water storage etc. Only provision for Analog/digital inputs with 0.1% accuracy of Full Scale Range is required. Sensors will not be in scope of bidder.

- v. RMS should have provision to give remote On/Off command to pump through farmer mobile app. to save ground water.
- b) Communication Modes:
 - i. Push Data on Event/Notification: such as pump on, pump off, protection operated, etc.
 - ii. Push Data Periodically: important parameters of solar pump (as mentioned above) should be pushed to central server on configurable interval. Interval should be configurable for 15 mins. However, if required, it should be possible to configure the periodic interval in multiple of 1 minute starting from 1 minute and up to 15 minutes. Further, in case of any abnormalities or event, RMS should push on event immediately.
 - iii. Command On Demand : It should be possible to send commands via GSM or GPRS to RMS either to control pump operations or to update configuration
- c) Communication Protocol: RMS should provide data on MQTT protocol to establish communication with thousands of systems.
- d) Security:
 - i. Communication between RMS and Server should be secured and encrypted using TLS/SSL/X.509 certificate etc.
 - ii. As a part of IoT protocol, Authentication and Authorization should be implemented using token/password mechanism
- e) Message Format: RMS should provide data in a JSON message format as required by respective SNA
- f) Data Storage: In case of unavailability of cellular network, RMS should store data locally and on availability of network it should push data to central Server. Local data storage should be possible for at least one year in case of unavailability of cellular network.
- g) Configuration update over the Air of multiple parameters such as IP, APN, Data logging Interval, Set Points etc. is essential. Software updating should be possible with 2G and even without the presence of SD card. Software updating process and/or failure to update software shouldn't disrupt pumping operations

L.3. MNRE Specifications of SPV water pumping systems

MINISTRY OF NEW AND RENEWABLE ENERGY

SPECIFICATION FOR SOLAR PHOTOVOLTAIC WATER PUMPING SYSTEMS

1. SCOPE

These specification covers design qualifications and performance specifications for Centrifugal Solar Photo Voltaic (SPV) Water Pumping Systems to be installed on a suitable bore-well, open well, water reservoir, water stream, etc., and specifies the minimum standards to be followed under New Scheme for Farmers launched by Government of India on 8.3.2019.

2. TERMINOLOGY

In addition to the terminology specified in 3 of IS 5120 and IEC 62253, the following shall also apply.

2.1 Static Water Depth — It is the depth of water level below the ground level when the pump is not in operation.

2.2 Draw-Down — It is the elevation difference between the depth of static water level and the consistent standing water level in tube well during operation of pump set.

2.3 Submergence — It is the minimum height of water level after drawdown above the pump suction casing.

2.4 Manometric Suction Lift — Manometric suction lift is the vacuum gauge/suction manometer reading in meter of water column when pump operates at suction lift.

2.5 Static Suction Lift — Static suction lift/head is the vertical distance between sump water level and center of pump inlet.

2.6 Daily Water Output — It is the total water output on a clear sunny day with three times tracking SPV panel, under the “Average Daily Solar Radiation” condition of 7.15 KWh / m² on the surface of SPV array (i.e. coplanar with the SPV Modules).

2.7 Wire to Water Efficiency — It is the combined system efficiency of SPV Converter/Controller with Inbuilt MPPT mechanism, Pump set and piping.

2.8 SPV Controller — Pump Controller converts the DC voltage of the SPV array into a suitable DC or AC, single or multi-phase power and may also include equipment for MPPT, remote monitoring, and protection devices.

2.9 Maximum Power Point Tracker (MPPT) — MPPT is an algorithm that is included in the pump controller used for extracting maximum available power from SPV array under a given condition. The voltage at which SPV array can produce maximum power is called 'maximum power point' voltage (or peak power voltage).

3. CONSTRUCTIONAL FEATURES

3.1 General

3.1.1 SPV Water Pumping System set uses the irradiance available through SPV array. The SPV array produces DC power, which can be utilized to drive a DC or an AC pump set using pump controller.

3.2 A SPV Water Pumping system typically consists of:

3.2.1 Pump Set

Pump set may be of any one of the following types:

- i) Mono-set pump;
- ii) Open well submersible pump;
- iii) Submersible pump;

3.2.2 Motor

The motor of the pump set may be of the following types:

- i) AC Induction Motor.
- ii) DC Motor [PMSM/BLDC/SRM (with brush or brushless)].

3.2.3 SPV Controller See 2.8

Note: Some controllers are inbuilt in the motors

3.2.4 Provision for remote monitoring for the pumps must be made in the pump controller through an integral arrangement having following basic functions:

- Controller must be assigned with a unique serial number and its live status must be observed remotely on online portal through login credentials.
- Live status must indicate whether controller is ON/ OFF
- The parameter i.e. the water output, water flow rate, in fault condition, array input voltage/ current, power and motor frequency should at logged at an interval of 10 minutes
- Controller must have a back up to store the data locally (at least for 1 year)

3.3 Solar Photo Voltaic (SPV) Array

3.3.1 SPV arrays contains specified number of same capacity, type and specification modules connected in series or parallel to obtain the required voltage or current output. The SPV water pumping system should be operated with a PV array minimum capacity in the range of **900 Watts peak to 9000 Watts peak**, measured under Standard Test Conditions (STC). Sufficient number of modules in series and parallel could be used to obtain the required voltage or current output. The power output of individual PV modules used in the PV array, under STC, should be a minimum of 200 Watts peak, with adequate provision for measurement tolerances. Use of PV modules with higher power output is preferred.

3.3.2 Modules supplied with the SPV water pumping systems shall have certificate as per IS14286/IEC 61215 specifications or equivalent National or International/ Standards. STC performance data supplied with the modules shall not be more than one year old.

3.3.3 Modules must qualify to IS/IEC 61730 Part I and II for safety qualification testing.

3.3.4 The minimum module efficiency should be minimum 15 percent and fill factor shall be more than 70 percent.

3.3.5 Modules must qualify to IEC TS 62804-1:2015 for the detection of potential-induced degradation - Part 1: Crystalline silicon (Mandatory in case the SPV array voltage is more than 600 V DC)

3.3.6 In case the SPV water pumping systems are intended for use in coastal areas the solar modules must qualify to IEC TS 61701:2011 for salt mist corrosion test.

3.3.7 The name plate shall conform the IS 14286/IEC 61215

3.3.8 Module to Module wattage mismatch in the SPV array mismatch shall be within ± 3 percent.

3.3.9 Variation in overall SPV array wattage from the specified wattages shall be within zero percent to +10 percent.

3.3.10 The PV Modules must be warranted for output wattage, which should not be less than 90% of the rated wattage at the end of 10 years and 80% of the rated wattage at the end of 25 years.

3.4 Motor-Pump Set

3.4.1 The SPV water pumping systems may use any of the following types of motor pump sets:

- a) Surface mounted motor-pump set
- b) Submersible motor-pump set
- c) Floating motor-pump set
- d) Any other type of motor pump set after approval from Ministry.

3.4.2 The “Motor-Pump Set” should have a capacity in the range of 1 HP to 10 HP and should have the following features:

- a) The mono block DC/ AC centrifugal motor pump set with the impeller mounted directly on the motor shaft and with appropriate mechanical seals which ensures zero leakage.
- b) The motor of the capacity ranging from 1 HP to 10 HP should be AC/DC. The suction and delivery head will depend on the site specific condition of the field.
- c) Submersible pumps could also be used according to the dynamic head of the site at which the pump is to be used.

3.4.3 The pump and all external parts of motor used in submersible pump which are in contact with water, should be of stainless steel of grade 304 or higher as required. The motor-pump set should have a 5 years warranty and therefore, it is essential that the construction of the motor and pump should be made using parts which have a much higher durability and do not need replacement or corrode for at least 5 years of operation after installation.

3.4.5 The suction/ delivery pipe shall be of HDPE or uPVC column pipes of appropriate size, electric cables, floating assembly, civil work and other fittings required to install the Motor Pump set. In case of HDPE pipes the minimum pressure rating of 8 kg/sqcm-PE100 grade for pumps up to 3 HP, 10 kg/sqcm-PE100 grade for 5 HP pumps and further higher minimum pressure rating for above 5 HP as appropriate shall be used.

3.5 Module Mounting Structures and Tracking System

3.5.1 The PV modules should be mounted on metallic structures of adequate strength and appropriate design, which can withstand load of modules and high wind velocities up to 150 km per hour. The raw material used and process for manufacturing of module mounting structure including welding of joints should conform to applicable IS. The module mounting structure should be hot dip galvanized according to IS 4759. Zinc content in working area of the hot dip galvanizing bath should not be less than 99.5% by mass.

3.5.2 To enhance the performance of SPV water pumping systems arrangement for seasonal tilt angle adjustment and three times manual tracking in a day should be provided. In order to make structure rigid, the gap between Telescopic pattern supports should be minimal, further, for bearing of center load of whole structure only pins should be used instead of threaded bolts.

3.5.3 The general hardware for structure fitment should be either SS 304 or 8.8 grade. Modules should be locked with antitheft bolts of SS 304 Grade. Foundation should be as per the site condition, based on the properties of Soil. Foundation can be done either with the help of 'J Bolt' (refer IS 5624 for foundation hardware) or direct piling, it should be decided as per the site and relevant IS i.e. IS 6403 / 456 / 4091 / 875 should be referred for foundation design.

3.5.4 Details of Module Mounting Structure for different capacity of SPV pumps are attached at Annexure-I. These are indicative of minimum standards and an Implementing Agency may specify higher standards.

3.6 SPV Controller

3.6.1 Maximum Power Point Tracker (MPPT) shall be included to optimally use the power available from the SPV array and maximize the water discharge.

3.6.2 The SPV Controller must have IP (65) protection or shall be housed in a cabinet having at least IP (65) protection.

3.6.3 Adequate protections shall be provided in the SPV Controller to protect the solar powered pump set against the following:

- a) Dry running;
- b) Open circuit;
- c) Accidental output short circuit;
- d) Under voltage;
- e) Reverse polarity;
- f) SPD to arrest high current surge; and
- g) Lightning arrestor.

3.6.4 A good reliable DC Circuit Breaker as per IS/IEC 60947-2 suitable for switching DC power ON and OFF shall be provided in the SPV Controller.

3.6.5 All cables used shall be as per IS 694. Suitable size of cable shall be used in sufficient length for inter-connection between the SPV array to SPV Controller and the SPV Controller to solar powered pump set. Selection of the cable shall be as per IS 14536.

3.6.6 Controller shall be integrated with GSM/GPRS Gateway with Geo tagging. GSM/GPRS Charges to be included in the Costing till the end of Warranty period of the Pump set.

3.7 Earthing Arrangement

3.7.1 Earthing of the motor shall be done as per IS 9283 in accordance with the relevant provisions of IS 3043. Separate earthing shall be provided for Controller, pump and SPV array.

3.7.2 For safety purpose, it shall be ensured during installation that the earthing is capable of taking care of leakage current.

3.7.3 In case of uPVC/HDPE pipes used as discharge pipe, a separate non-corrosive, low resistance conductor from motor earth terminal to control panel earth terminal shall be provided for earthing.

3.7.4 A lightening arrestor shall be provided with every SPV Water Pumping System.

3.8 Use of indigenous components

It will be mandatory to use indigenously manufactured solar modules with indigenous mono/multi crystalline silicon solar cells. Further, the motor-pump-set, controller and balance of system should also be manufactured indigenously. The vendor has to declare the list of imported components used in the solar water pumping system.

4. PERFORMANCE REQUIREMENTS

4.1 Under the “Average Daily Solar Radiation” condition of 7.15 KWh / sq.m. on the surface of PV array (i.e. coplanar with the PV Modules), the minimum water output from a Solar PV Water Pumping System at different “Total Dynamic Heads” should be as specified below :

For D.C. Motor Pump Set:

- i) 110 liters of water per watt peak of PV array, from a Total Dynamic Head of 10 meter (Suction head, if applicable, maximum of 7 meter) and with the shut off head being at least 12 meter.
- ii) 55 liters of water per watt peak of PV array, from a Total Dynamic Head of 20 meter (Suction head, if applicable, up to a maximum of 7 meters) and with the shut off head being at least 25 meter.
- iii) 38 liters of water per watt peak of PV array, from a Total Dynamic Head of 30 meters and the shut off head being at least 45 meter.
- iv) 23 liters of water per watt peak of PV array, from a Total Dynamic Head of 50 meter and the shut off head being at least 70 meter.

- v) 15 liters of water per watt peak of PV array, from a Total Dynamic Head of 70 meters and the shut off head being at least 100 meter.
- vi) 10.5 liters of water per watt peak of PV array, from a Total Dynamic Head of 100 meters and the shut off head being at least 150 meter.

The actual duration of pumping of water on a particular day and the quantity of water pumped could vary depending on the solar intensity, location, season, etc.

Indicative performance specifications for the Shallow and Deep well SPV Water Pumping Systems are given in the Annexure II.

For A.C. Induction Motor Pump Set:

- i) 99 liters of water per watt peak of PV array, from a Total Dynamic Head of 10 meter (Suction head, if applicable, maximum of 7 meters) and with the shut off head being at least 12 meter.
- ii) 49 liters of water per watt peak of PV array, from a Total Dynamic Head of 20 meter (Suction head, if applicable, up to a maximum of 7 meters) and with the shut off head being at least 25 meter.
- iii) 35 liters of water per watt peak of PV array, from a Total Dynamic Head of 30 meter and the shut off head being at least 45 meter.
- iv) 21 liters of water per watt peak of PV array, from a Total Dynamic Head of 50 meter and the shut off head being at least 70 meter.
- v) 14 liters of water per watt peak of PV array, from a Total Dynamic Head of 70 meter and the shut off head being at least 100 meter.
- vi) 9 liters of water per watt peak of PV array, from a Total Dynamic Head of 100 meter and the shut off head being at least 150 meter.

The actual duration of pumping of water on a particular day and the quantity of water pumped could vary depending on the solar intensity, location, season, etc.

Indicative performance specifications for the Shallow and Deep well SPV Water Pumping Systems are given in the Annexure III.

5. TESTS FOR HYDRAULIC AND ELECTRICAL PERFORMANCE OF PUMPSET

5.1 The motor-pump set shall be tested independently for hydraulic and electrical performance as per the relevant IS specification including following test

- a) Constructional requirements/features
- b) General requirements
- c) Design features
- d) Insulation resistance test

- e) High voltage test
- f) Leakage current test

5.2 Testing of SPV Water Pumping Systems shall be done as per procedure specified by the MNRE.

6. GUARANTEE OF PERFORMANCE

6.1 The SPV Water Pumping Systems shall be guaranteed for their performance of the nominal volume rate of flow and the nominal head at the guaranteed duty point as specified in 7.1 under the “Average Daily Solar Radiation” condition of 7.15 KWh/m² on the surface of SPV array (i.e. coplanar with the Photo Voltaic (PV) Modules). The actual duration of pumping of water on a particular day and the quantity of water pumped could vary depending on the solar intensity, location, season, etc.

6.2 Solar Photo Voltaic Water Pumping Systems shall be guaranteed by the manufacturer against the defects in material and workmanship under normal use and service for a period of at least 60 months from the date of commissioning.

6.3 Sufficient spares for trouble free operation during the Warrantee period should be made available as and when required

7. MARKING AND PARAMETERS TO BE DECLARED BY THE MANUFACTURER

7.1 The motor pump-set and Controller used in SPV Water Pumping Systems shall be securely marked with the following parameters declared by the manufacturer:

7.1.1 Motor Pump-set

- a) Manufacturer's name, logo or trade-mark;
- b) Model, size and SI No of pump-set;
- c) Motor Rating (kW / HP);
- d) Total head, m, at the guaranteed duty point;
- e) Capacity (LPD) at guaranteed head;
- f) Operating head range, m;
- g) Maximum Current (A);
- j) Voltage Range (V) and;
- k) Type - AC or DC Pump set; &
- l) Photo Voltaic (PV) Array Rating in Watts peak (W_p)

7.1.2 Controller

- a) Manufacturer's name, logo or trade-mark;
- b) Model Number;
- c) Serial Number;

- d) Voltage Range;
- e) Power Range in kW for Controller; and
- f) Current rating (A)

8. OPERATION AND MAINTENANCE MANUAL

8.1 An Operation and Maintenance Manual, in English and the local language, should be provided with the solar PV pumping system. The Manual should have information about solar energy, photovoltaic, modules, DC/AC motor pump set, tracking system, mounting structures, electronics and switches. It should also have clear instructions about mounting of PV module, DO's and DONT's and on regular maintenance and Trouble Shooting of the pumping system. Helpline number and Name and address of the Service Centre and contact number of authorized representative to be contacted in case of failure or complaint should also be provided. A warranty card for the modules and the motor pump set should also be provided to the beneficiary.

**Specifications for Dual Axis Manual Tracking Type
Module Mounting Structure (MMS) for Solar Water Pumping System**

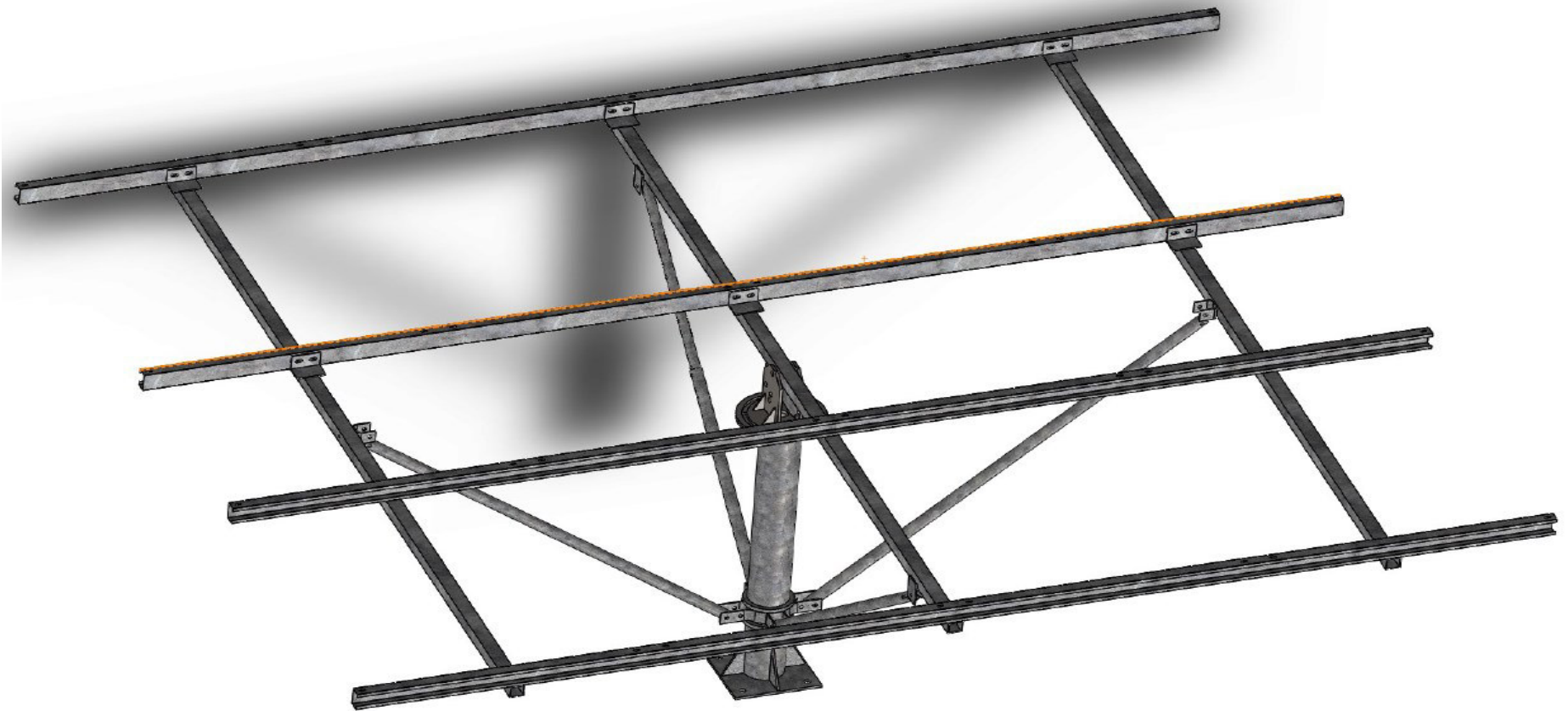

Standard MMS for 4, 6 and 8 solar modules have been specified. These standard MMS may be used in combinations for different capacities of solar water pumping systems as follows:

1. Standard MMS of 4 Modules for 1 HP
2. Standard MMS of 6 Modules for 2 HP
3. Combination of standard MMS of 4 Modules and 6 Modules for 3 HP
4. Combination of two standard MMS of 8 Modules for 5 HP
5. Combination of three standard MMS of 8 Modules for 7.5 HP

and so on....

Specifications of main parts used in MMS are given below:

1. Centre Shaft: - Centre shaft used in structure should be of minimum 139 OD with minimum thickness of 4 mm with base plate minimum 10 mm thickness if used and foundation hardware should be as per IS 5624. For system without base plate i.e. direct piling is should be as per the site condition based on the properties of Soil and refer (IS 6403 / 456 / 4091 / 875) for foundation design.
2. Rafters: - The Main and secondary rafter used in structure should be of either SHS & RHS pipe sections.
3. Purlin: - Mounting Purlins used in the structure should be made of Cold form steel section as per IS 1079 with minimum thickness of 2mm.

4. Provision for Seasonal Tilt: - In one structure at least four telescopic supports (three may be used in MMS for 4 modules) either round hollow sections or square hollow section to be provided to support the mounting structure.
5. Provision for Daily Tracking: - Provision for Daily tracking should be provided by the way of providing min. 8 mm thick metal sheet with precision cut grooves.
6. Module Locking System: - Modules should be locked with antitheft bolts of SS 304 Grade.
7. General Hardware for Structure Fitment: - Either SS 304 or 8.8 grade hardware should be used for fitment.
8. Hot Dip Galvanizing: - All structure parts should be hot dip galvanized according to IS 4759.
9. Tolerance for fabrication: - Tolerance for fabrication of steel structure should as per IS 7215.
10. Welding: - Welding should be done as per IS: - 822 & grade of welding wire should be (ER70S-6).

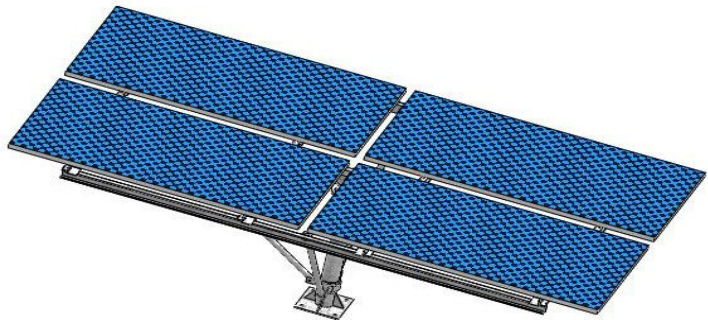

4 Module MMS

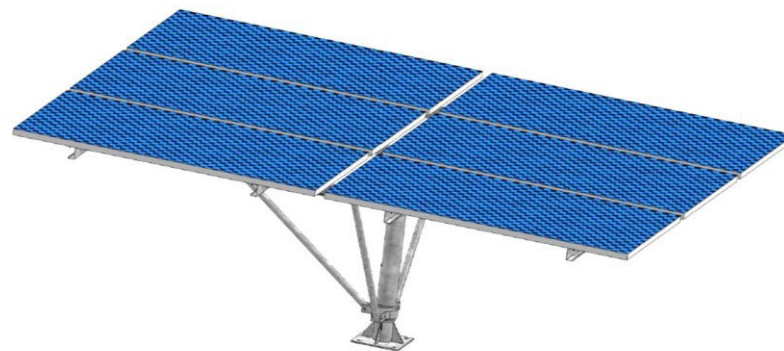

6 Module MMS

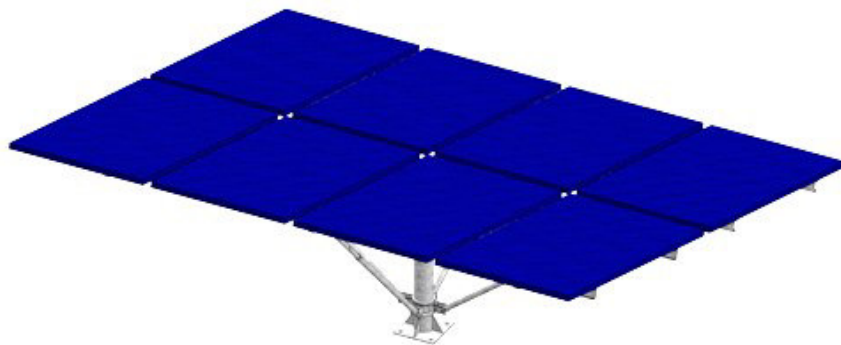

8 Module MMS

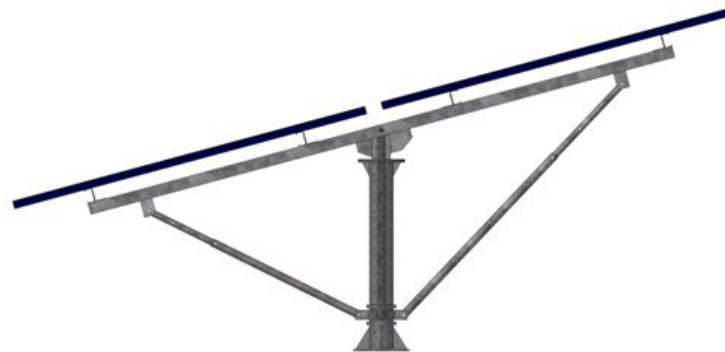

Side view

Raw material test certificates (MTC) of all types of raw material used in dual axis manual tracking type MMS as per appropriate IS code should be submitted along with dispatch documents.

Tests to be performed on Dual Axis Manual Tracking Type MMS for Solar Water Pumping System: -

1. For ascertaining proper welding of structure part following should be referred.
 - a. Weld wire grade should be of grade **(ER 70 S - 6)**
 - b. D.P. Test (Pin Hole / Crack) **(IS 822)**
2. For ascertaining hot dip galvanizing of fabricated structure following should be referred: -
 - a. Min coating required should be as per IS 4759.
 - b. Testing of galvanized material.
 - i. Preece Test (CuSO₄ Dip Test) **(IS 2633)**
 - ii. Mass of Zinc **(IS 6745)**
 - iii. Adhesion Test **(IS 2629)**

Part1 – Mail Column

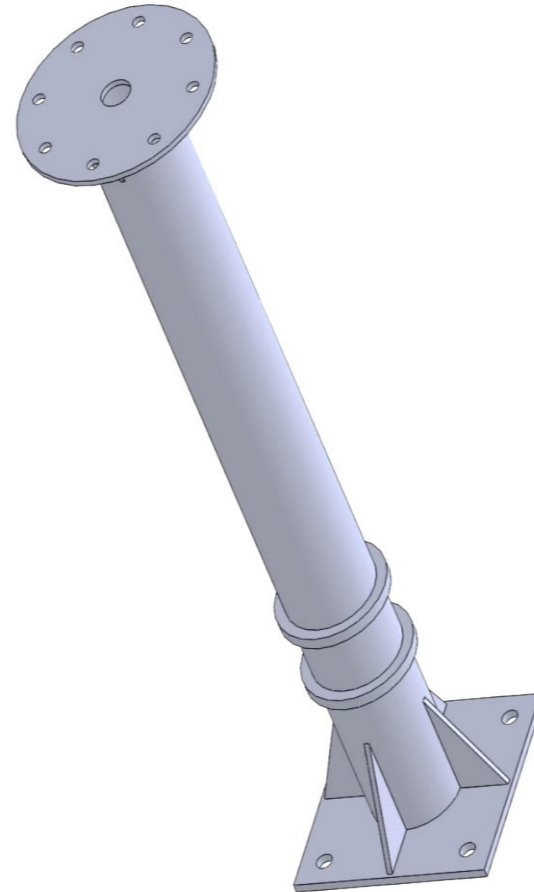
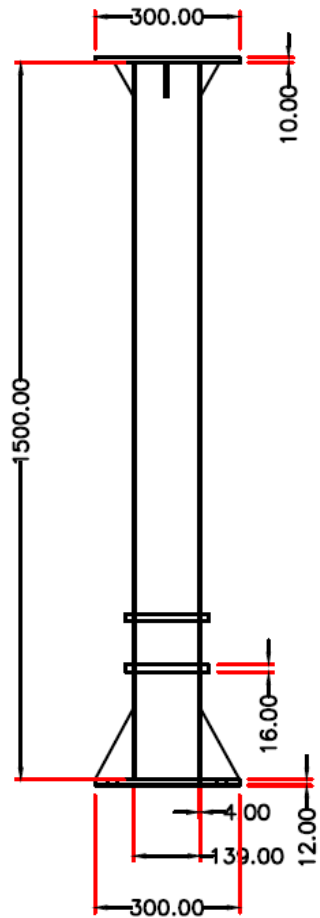

Notes: -

1. All Dimensions are in mm.
2. Main Column material grade should be YST - 240 as per: -IS: 1161 / 1239 & E250 as per: - IS: 1079 / 2062.

Part 2 – Top Plate

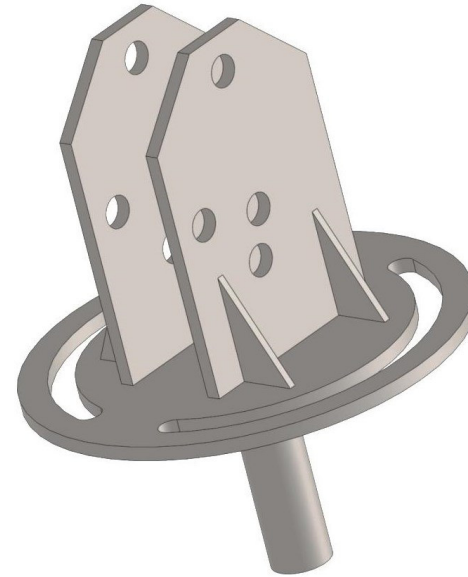
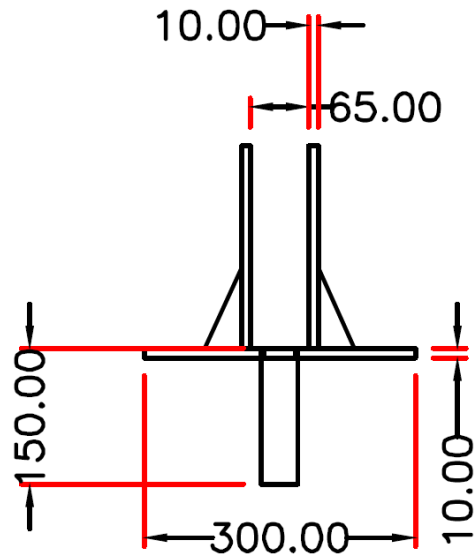

Notes: -

1. All Dimensions are in mm.
2. Top Plate material grade should be YST - 240 as per: -IS: 1161 / 1239 & E250 as per: - IS: 1079 / 2062.

Part 3 – Main Tube

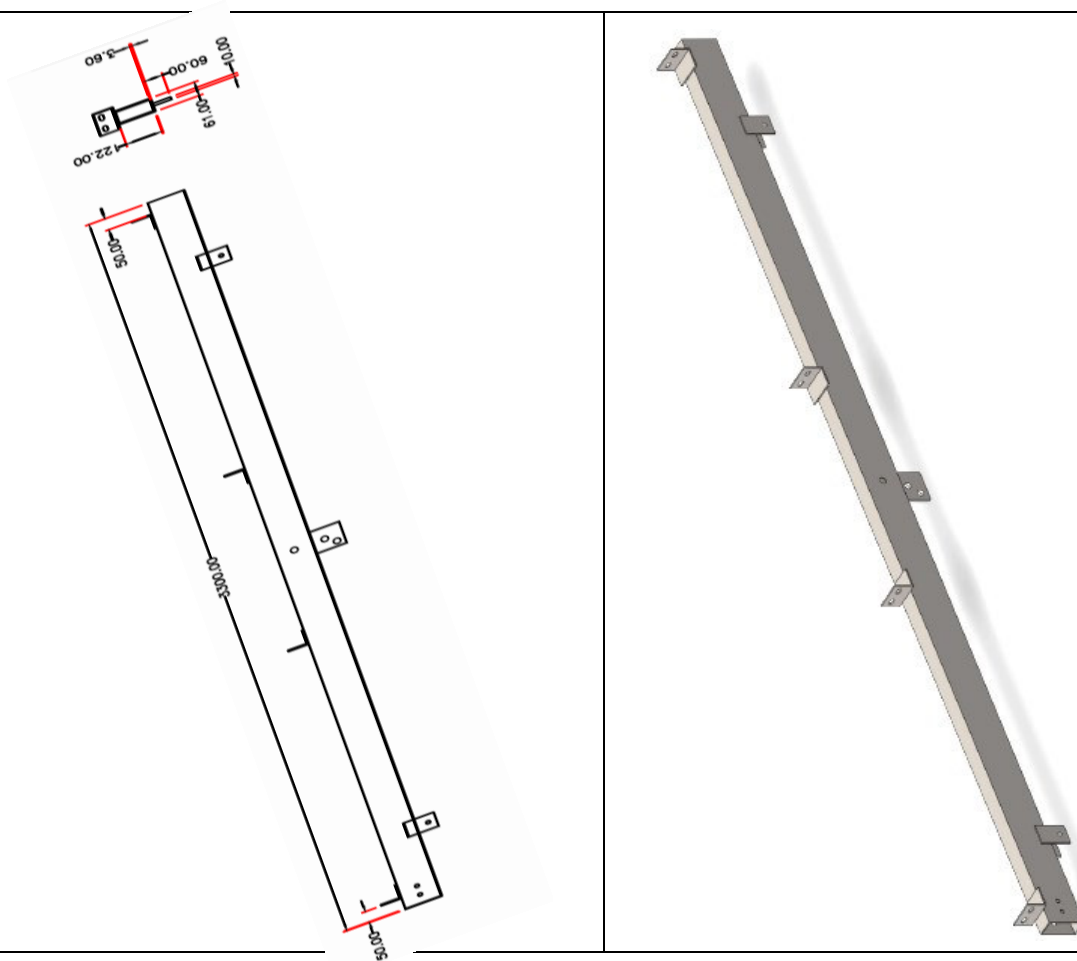

Notes: -

1. All Dimensions are in mm.
2. Main Tube material grade should be YST - 240 as per: -IS: 1161 / 1239 & E250 as per: - IS: 1079 / 2062.

Part 4 – Side Tube

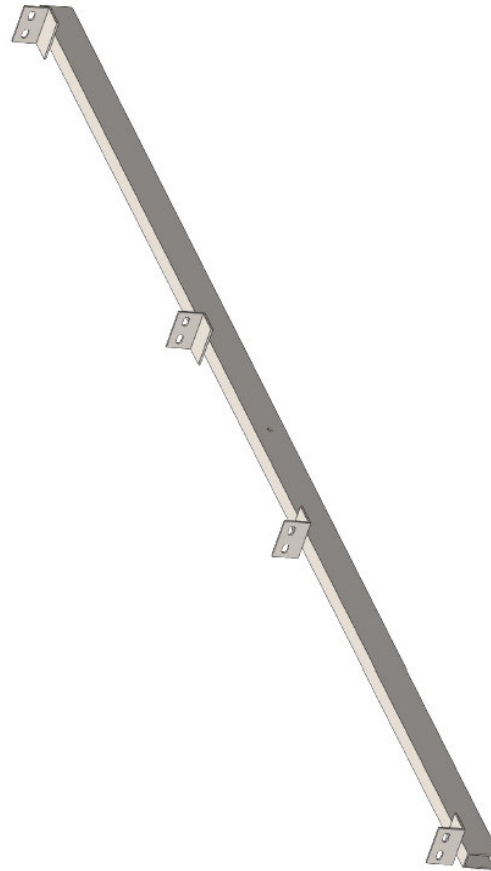
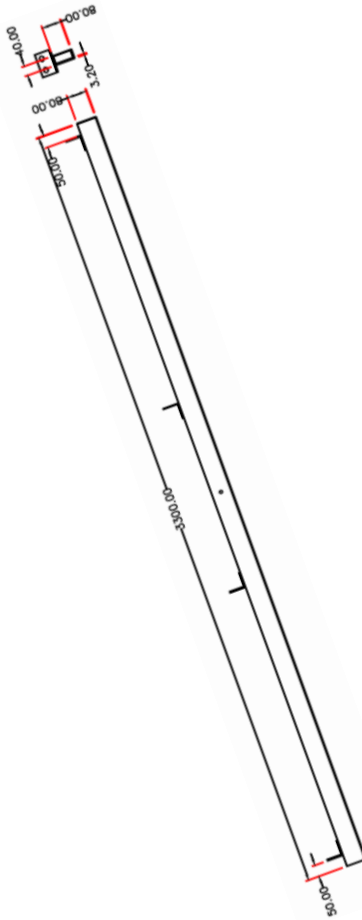

Notes: -

1. All Dimensions are in mm.
2. Side Tube material grade should be YST - 240 as per: -IS: 1161 / 1239 & E250 as per: - IS: 1079 / 2062.

Part 5 – Purlin

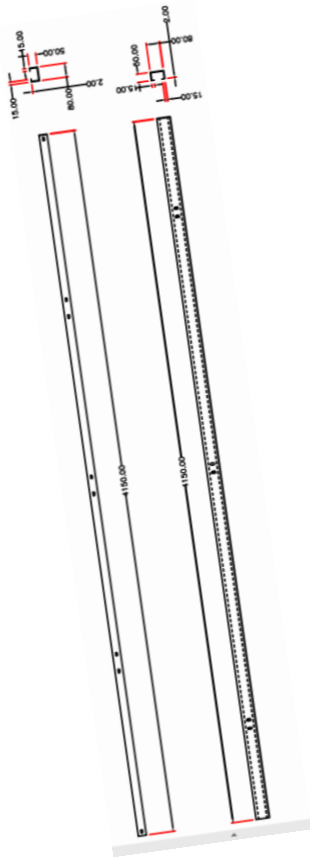

Notes: -

1. All Dimensions are in mm.
2. Mounting Purlin material grade should be E250 as per: - IS: 1079 / 2062 & IS: 811.

Part 6 – Clamp with Blade

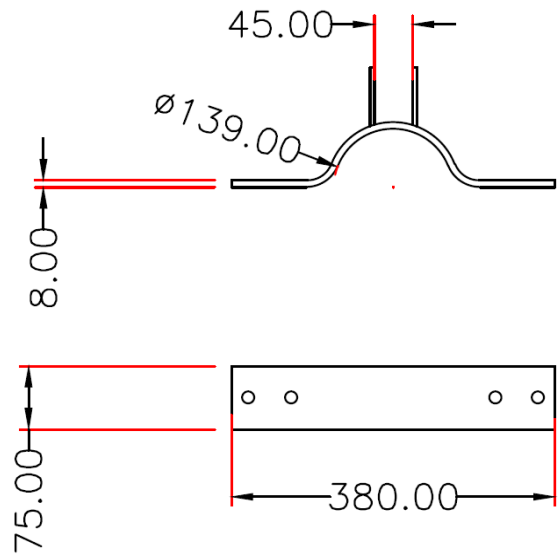

Notes: -

1. All Dimensions are in mm.
2. Clamp with Blade material grade should be as per: - IS: 1079 & E250 as per: - IS: 2062.

Part 7 – Supporting Pipes

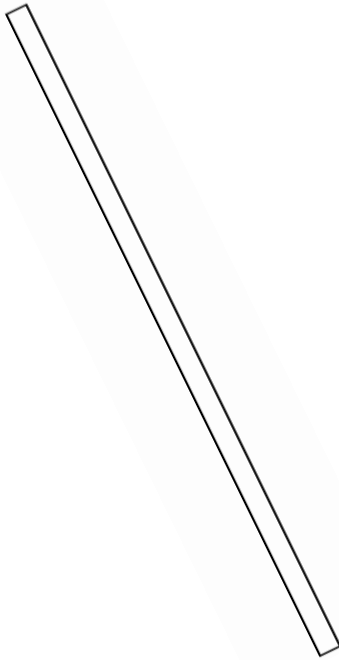

Notes: -

1. All Dimensions are in mm.
2. Supporting Pipes material grade should be YST - 240 as per: -IS: 1161 / 1239 & E250 as per: - IS: 1079 / 2062.

Bill of Quantity for main parts of MMS for Solar Water Pumping System

SR. NO.	PART NAME	CROSS SECTION DETAIL	LENGTH (MM)	QUANTITY PER SET
A	Common for MMS for 4, 6 and 8 Modules			
1.	MAIN POLE	139 OD	1500	1
2.	TOP PLATE	300 OD	--	1
3.	CLAMP WITH BLADE	75X8	380	2
4.	SUPPORTING PIPES	41 OD & 33 OD	--	6
B	Different for MMS for 4, 6 and 8 Modules			
5.	MAIN TUBE			
	4 and 6 Module	60X60X3.6	3300	1
	8 Modules	122X61X3.6	3300	1
6.	SIDE TUBE			
	4 and 6 Module	50X50X3.6	3300	2
	8 Modules	80X40X3.2	3300	2
7.	MOUNTING PURLIN			
	4 Module	80X50X15X2	2050	4
	6 Module	80X50X15X2	3100	4
	8 Modules	80X50X15X2	4150	4

FOUNDATION DESIGN FOR 4/6 MMS

BOM

TMT BAR	LENGTH	WEIGHT	QUANTITY	TOTAL WEIGHT
16 MM	1000 MM	1.578 KG	8 PCS	12.6 KG
8 MM	2400 MM	0.950 KG	4 PCS	3.8 KG
8 MM	1250 MM	0.500 KG	4 PCS	2 KG

BOM

BLOCK	WIDTH	LENGTH	HEIGHT	VOLUME
RCC COLUMN	0.600 M	0.600 M	0.900 M	0.324 CU.M
PCC	0.900 M	0.900 M	0.200 M	0.162 CU.M

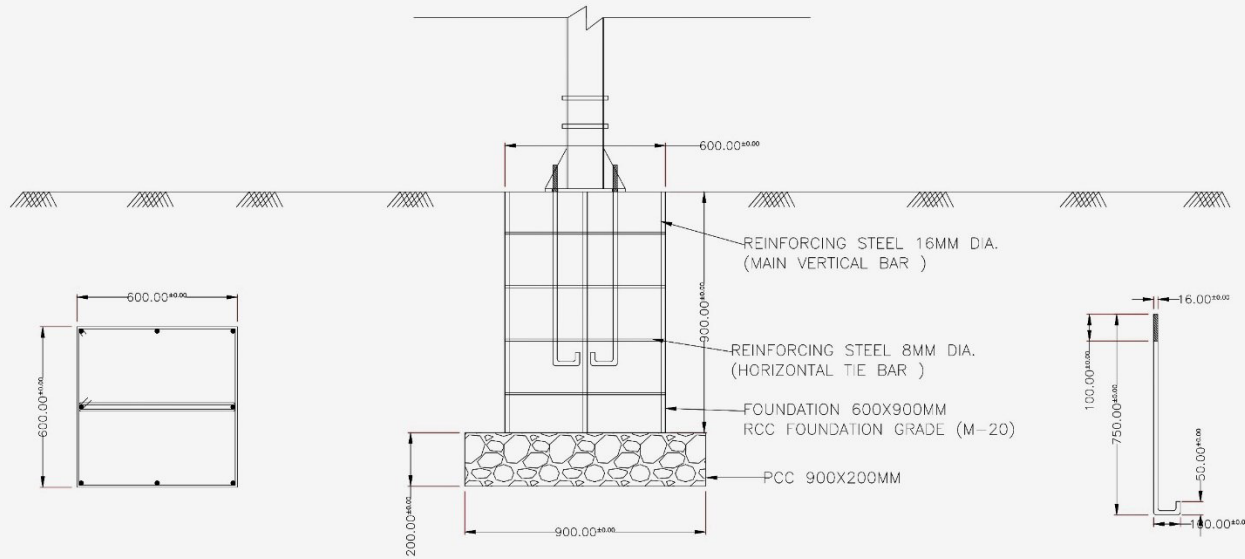

Note:-All dimensions are critical & in mm. Please maintain the
 dimensions. Welding dimension should be maintained 5 mm.

FOUNDATION DESIGN FOR 8 MMS

BOM

TMT BAR	LENGTH	WEIGHT	QUANTITY	TOTAL WEIGHT
16 MM	1300 MM	2.05 KG	8 PCS	16.4 KG
8 MM	2400 MM	0.950 KG	6 PCS	5.7 KG
8 MM	1250 MM	0.500 KG	6 PCS	3 KG

BOM

BLOCK	WIDTH	LENGTH	HEIGHT	VOLUME
RCC COLUMN	0.600 M	0.600 M	1.20 M	0.432 CU.M
PCC	0.900 M	0.900 M	0.200 M	0.162 CU.M

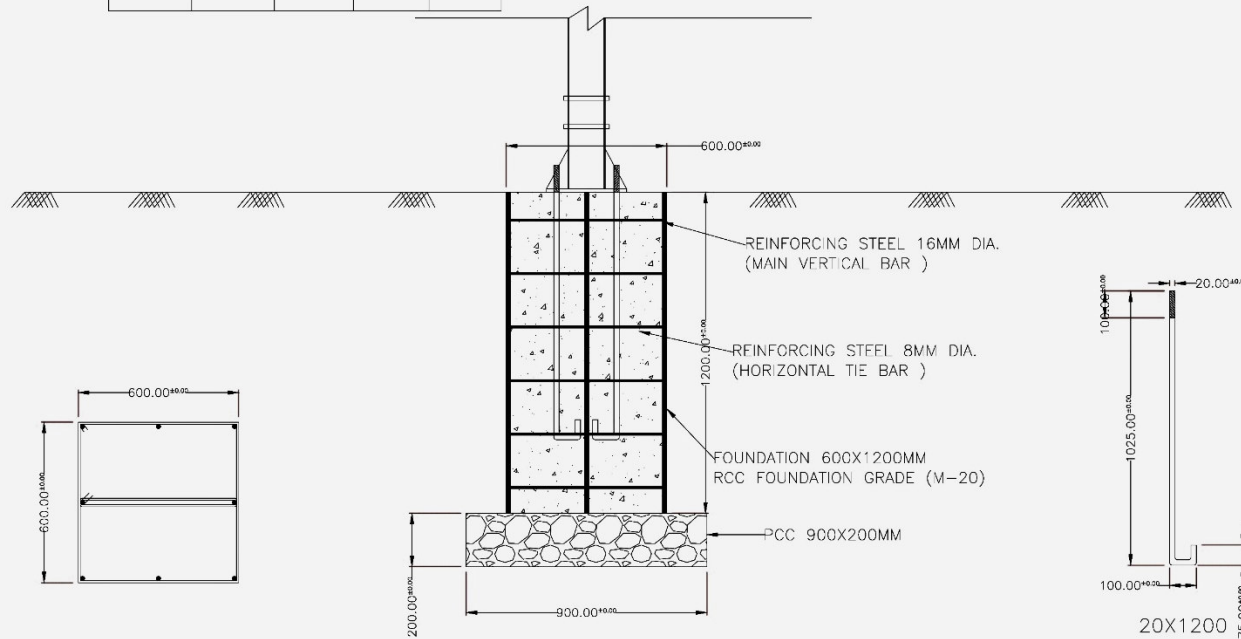

Note:-All dimensions are critical & in mm. Please maintain the dimensions. Welding dimension should be maintained 5 mm.

ANNEXURE – II

Indicative Technical Specifications of Shallow Well (Surface) Solar Pumping Systems with D.C. Motor Pump Set with Brushes or Brushless D.C. (B.L.D.C.)

Description	Model-I	Model-II	Model-III	Model-IV	Model-V	Model-VI	Model-VII	Model-VIII	Model-IX	Model-X	Model-XI	Model-XII	Model-XIII
PV array (Wp)	900	1800	2700	2700	4800	4800	4800	6750	6750	6750	9000	9000	9000
Motor Pump-set capacity (HP)	1	2	3	3	5	5	5	7.5	7.5	7.5	10	10	10
Shut Off Dynamic Head (meters)	12	12	12	25	12	25	45	12	25	45	12	25	45
Water output * (Liters per day)	99000 (from a total head of 10 meters)	198000 (from a total head of 10 meters)	297000 (from a total head of 10 meters)	148500 (from a total head of 20 meters)	528000 (from a total head of 10 meters)	264000 (from a total head of 20 meters)	182400 (from a total head of 30 meters)	742500 (from a total head of 10 meters)	371250 (from a total head of 20 meters)	256500 (from a total head of 30 meters)	990000 (from a total head of 10 meters)	495000 (from a total head of 20 meters)	342000 (from a total head of 30 meters)

* Water output figures are on a clear sunny day with three times tracking of SPV panel, under the “Average Daily Solar Radiation” condition of 7.15 kWh/ sq.m. on the surface of PV array (i.e. coplanar with the PV Modules).

Notes:

1. Suction head, if applicable, maximum 7 meters.
2. For higher or lower head / PV capacity, or in between various models; water output could be decided as per the clause 4 (i.e. Performance Requirements) specified earlier.
3. If submersible pumps are used in lieu of surface pumps, the water output must match that of the surface pumps as specified in this table.

ANNEXURE – II (CONTD.)

Indicative Technical Specifications of Solar Deep well (submersible) Pumping Systems with D.C. Motor Pump Set with Brushes or Brushless D.C. (B.L.D.C.)

Description	Model-I	Model-II	Model-III	Model-IV	Model-V	Model-VI	Model-VII	Model-VIII	Model-IX	Model-X	Model-XI	Model-XII	Model-XIII	Model-XIV
PV array (Wp)	1200	1800	3000	3000	3000	4800	4800	4800	6750	6750	6750	9000	9000	9000
Motor Pump-set capacity (HP)	1	2	3	3	3	5	5	5	7.5	7.5	7.5	10	10	10
Shut Off Dynamic Head (meters)	45	45	45	70	100	70	100	150	70	100	150	70	100	150
Water output * (Liters per day)	45600 (from a total head of 30 meters)	68400 (from a total head of 30 meters)	114000 (from a total head of 30 meters)	69000 (from a total head of 50 meters)	45000 (from a total head of 70 meters)	110400 (from a total head of 50 meters)	72000 (from a total head of 70 meters)	50400 (from a total head of 100 meters)	155250 (from a total head of 50 meters)	101250 (from a total head of 70 meters)	70875 (from a total head of 100 meters)	207000 (from a total head of 50 meters)	135000 (from a total head of 70 meters)	94500 (from a total head of 100 meters)

* Water output figures are on a clear sunny day with three times tracking of SPV panel, under the “Average Daily Solar Radiation” condition of 7.15 kWh/ sq.m. on the surface of PV array (i.e. coplanar with the PV Modules).

Notes:

1. For higher or lower head / PV capacity, or in between various models; water output could be decided as per the clause 4 (i.e. Performance Requirements) specified earlier.
2. If surface pumps are used in lieu of submersible pumps, the water output must match that of the submersible pumps as specified in this table.

ANNEXURE – III

Indicative Technical Specifications of Shallow Well (Surface) Solar Pumping Systems with A.C. Induction Motor Pump Set

Description	Model-I	Model-II	Model-III	Model-IV	Model-V	Model-VI	Model-VII	Model-VIII	Model-IX	Model-X	Model-XI	Model-XII	Model-XIII
PV array (Wp)	900	1800	2700	2700	4800	4800	4800	6750	6750	6750	9000	9000	9000
Motor Pump-set capacity (HP)	1	2	3	3	5	5	5	7.5	7.5	7.5	10	10	10
Shut Off Dynamic Head (meters)	12	12	12	25	12	25	45	12	25	45	12	25	45
Water output * (Liters per day)	89100 (from a total head of 10 meters)	178200 (from a total head of 10 meters)	267300 (from a total head of 10 meters)	132300 (from a total head of 20 meters)	475200 (from a total head of 10 meters)	235200 (from a total head of 20 meters)	168000 (from a total head of 30 meters)	641025 (from a total head of 10 meters)	330750 (from a total head of 20 meters)	236250 (from a total head of 30 meters)	890000 (from a total head of 10 meters)	441000 (from a total head of 20 meters)	324000 (from a total head of 30 meters)

* Water output figures are on a clear sunny day with three times tracking of SPV panel, under the “Average Daily Solar Radiation” condition of 7.15 kWh/ sq.m. on the surface of PV array (i.e. coplanar with the PV Modules).

Notes:

1. Suction head, if applicable, maximum 7 meters.
2. For higher or lower head / PV capacity, or in between various models; water output could be decided as per the clause 4. (i.e. Performance Requirements) specified earlier.
3. If submersible pumps are used in lieu of surface pumps, the water output must match that of the surface pumps as specified in this table.

ANNEXURE – III (CONTD.)

Indicative Technical Specifications of Solar Deep well (submersible) Pumping Systems with A.C. Induction Motor Pump Set

Description	Model-I	Model-II	Model-III	Model-IV	Model-V	Model-VI	Model-VII	Model-VIII	Model-IX	Model-X	Model-XI	Model-XII	Model-XIII	Model-XIV
PV array (Wp)	1200	1800	3000	3000	3000	4800	4800	4800	6750	6750	6750	9000	9000	9000
Motor Pump-set capacity (HP)	1	2	3	3	3	5	5	5	7.5	7.5	7.5	10	10	10
Shut Off Dynamic Head (meters)	45	45	45	70	100	70	100	150	70	100	150	70	100	150
Water output * (Liters per day)	42000 (from a total head of 30 meters)	63000 (from a total head of 30 meters)	105000 (from a total head of 30 meters)	63000 (from a total head of 50 meters)	42000 (from a total head of 70 meters)	100800 (from a total head of 50 meters)	67200 (from a total head of 70 meters)	43200 (from a total head of 100 meters)	141750 (from a total head of 50 meters)	94500 (from a total head of 70 meters)	60750 (from a total head of 100 meters)	189000 (from a total head of 50 meters)	126000 (from a total head of 70 meters)	81000 (from a total head of 100 meters)

* Water output figures are on a clear sunny day with three times tracking of SPV panel, under the “Average Daily Solar Radiation” condition of 7.15 kWh/ sq.m. on the surface of PV array (i.e. coplanar with the PV Modules).

Notes:

1. For higher or lower head / PV capacity, or in between various models; water output could be decided as per the clause 4 (i.e. Performance Requirements) specified earlier.
2. If surface pumps are used in lieu of submersible pumps, the water output must match that of the submersible pumps as specified in this table.