

Commissioning & Start-up **Directory**



INTEGRATED **S**ERVICE **S**OLUTIONS



CHAPTER 1	INTRODUCTION	4
CHAPTER 2	COMMISSIONING & START UP SERVICE	5
	2.1 Commissioning Standard Implementation Path	6
	2.2 The Home Office Phase	7
	2.2.1 (Pre-) Commissioning Engineering	8
	2.2.2 (Pre-) Commissioning and Start-up Manuals	11
	2.3 The Site Phase	14
	2.3.1 Mechanical Completion Check & Interim Handover	14
	2.3.2 Pre-Commissioning Period	15
	2.3.3 Commissioning & Start-Up Period	16
	2.4 System Turnover Management	17
CHAPTER 3	DEDICATED TOOL	18



CHAPTER
1

Introduction

ISS International is well experienced in Pre-Commissioning and Commissioning activities and can provide the in-depth experience, guidance and qualified personnel necessary to deliver a unit **Safely** prepared and ready to achieve a successful **Start-up**.

The senior technicians and the engineers who make up our staff have been all chosen on the basis of the professionalism, versatility and ability to adapt themselves to the different environment and industrial culture of our customers covering both "Home-Office" and "Site" phases providing specific services as well as the implementation of fully integrated projects even on a "Turn-Key" approach.

Manage your business even before "you turn the key"

CHAPTER
2

Commissioning & Start-up Service

The standard definitions used are as follows:

Pre-Commissioning	Pre-Commissioning activities start when the plant, or system, achieves Mechanical Completion. Frequently however, Pre-Commissioning activities overlap Mechanical Completion activities and for this reason the plant should be separated into easily manageable system package, each system package will be Pre-Commissioned as a whole and isolations at the boundaries of the system package will be maintained until the completion of Pre-Commissioning activities. Pre-Commissioning activities include: checking for design conformity, checking the status of electrical, mechanical and instrument installations, running-in of equipment, flushing and cleaning activities, drying, etc.
Commissioning	Commissioning is the phase in a project when design process fluids are introduced to the process. Note that for hydrocarbon systems the commissioning activities commence with inerting operations. Commissioning activities normally consist of activities associated with running or operating the plant and include operating adjustments necessary for satisfactory operation of the plant or part thereof. Also included are "Functional checks" which are methods used to prove that an item of mechanical equipment or control system functions correctly.
Start-up	Start-up is the point in a project where process fluids and conditions are established with the intent of making products.
System	A section of the plant or facility that can be Pre-Commissioned and commissioned independently, but in parallel, with other sections of the plant or facility under construction.
Unit Ready for Commissioning	This is the point in a project where all utilities are commissioned and operational and the unit is ready to accept the introduction of hydrocarbons.
Unit Ready for Start-up	This is the point in a project where the unit is ready to establish process conditions with the intent of making product.



2.1 COMMISSIONING STANDARD IMPLEMENTATION PATH

ISS International Standard Pre-Commissioning, Commissioning and Start-up Methodology is organized considering the entire project frame and having in mind the following objective: TO CONDUCT THE PLANT IN OPERATION.

The entire Commissioning Service process is developed according to the following phases:

Home Office Phase

- Preparatory Works (Home office Activities).

Site Phase

- Mechanical Completion Check (according to API 700 Sec. 3 & 4)
- Pre-Commissioning
- Commissioning & Start-Up
- Performance Tests.

The **ISS International** Standard implementation path is shown in the following figure:

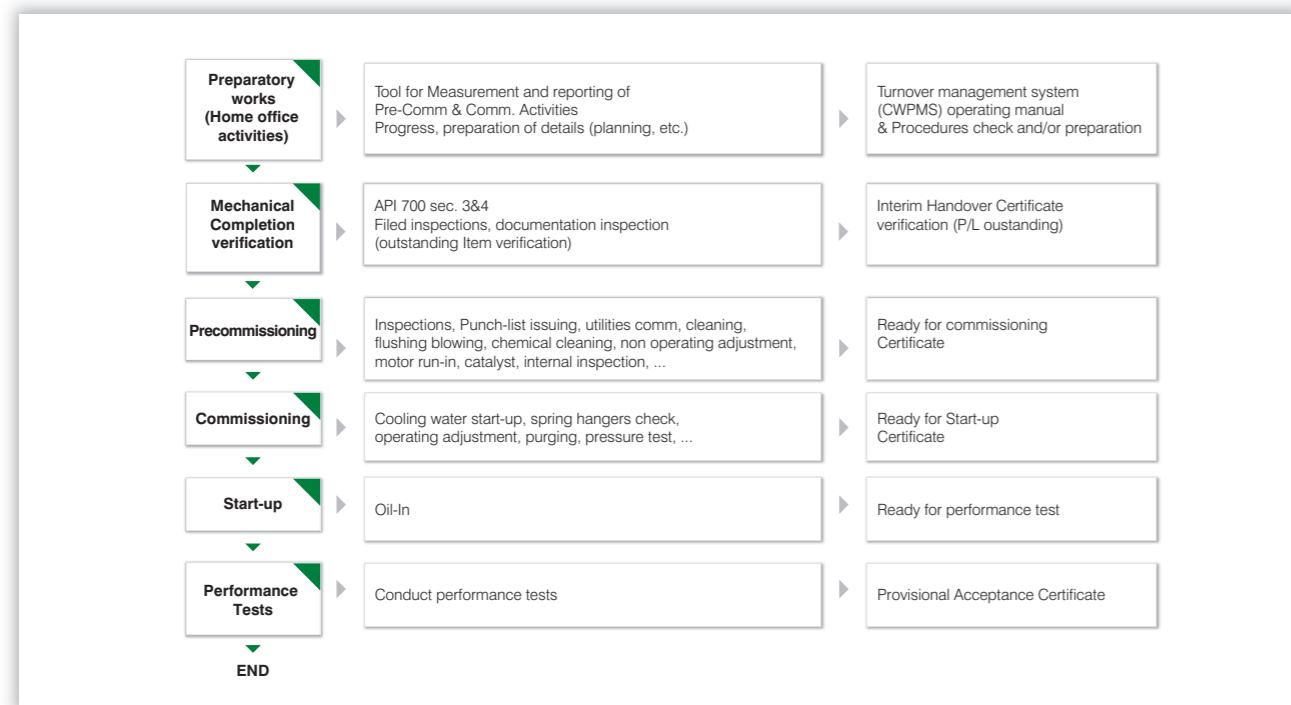

2.2 THE HOME OFFICE PHASE

During this phase the preparation of Tool for measurement and reporting of Pre-Commissioning & Commissioning activities Progress, project detailed plan, project detailed and operative deployment plan, preparation of detailed "procedures", etc. take place.

During this phase the following activities will be carried out, but not limited to:

(Pre-)Commissioning Engineering

- System/Subsystem definition
 - Marked-up P&ID by System
- Detailed Pre-Commissioning / Commissioning Execution Plan
 - Organization Chart
 - Deployment plan per activity
- Generic Method Statement
- Commissioning Plan and Critical Path Network
 - Activities to be performed by System
- Organisation Roles And Responsibilities
- Punch-listing method Statement
- Commissioning input to the Design Process
 - P&ID Review
 - HazOp Reviews
- Commissioning Spare Parts & Consumables
- Sample and Testing Schedule
- Equipment Data Logging

(Pre-)Commissioning & Start-Up Manual

- Development of (Pre-)Commissioning and Start-Up Manuals
- Quality Manual
 - Quality Control Plan
 - Quality Control Forms

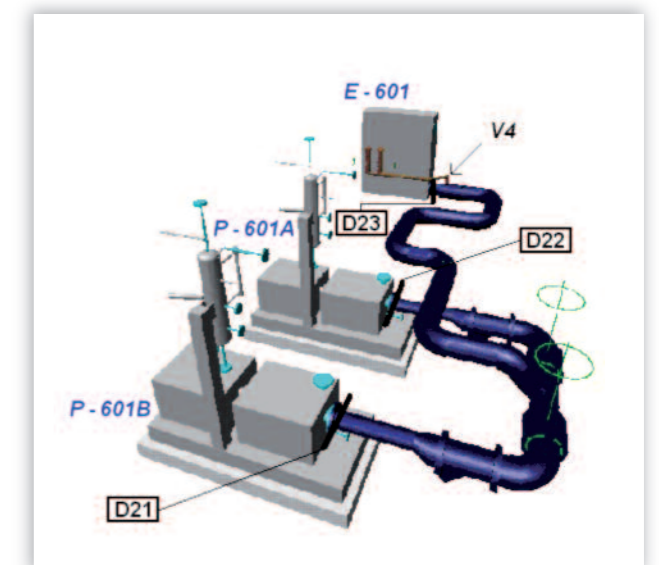

System Turnover

- Handover: The Turnover Management System for Commissioning (TMSCOM®). Tool implementation and configuration.



2.2.1 (Pre-)Commissioning Engineering

ISS International commissioning and technical personnel will produce a number of deliverables. The documents will entirely fulfil the contractual requirements for the pre-commissioning, commissioning, start-up and initial operation of the complex as per customer documents.

Main activities of these phase can be summarized as follows:

System/Subsystem Definition

To enable a smooth transition from construction to commissioning it is required to complete construction work in small packages (known as systems). This enables Pre-Commissioning work to progress from an earlier point in the schedule, thus reducing the final pre-commissioning peak workload substantially. However, systemised turnover is more complex to co-ordinate and manage due to the:

- increase in boundaries between the construction and commissioning groups.
- increase in parallel activities during the final stages of construction.

The size and content of a system changes for each project, however it is essential to take the following points into consideration when defining system size and content.

- Units separated into a large number of systems have high manpower expenditure for the pre-commissioning phase.
- Units separated into a low number of systems have an uneven workload pattern throughout the pre-commissioning phase.

- Hydro-test boundaries should coincide with system boundaries, where possible.
- Systems should be defined by colour coding a set of A3 P&IDs. System boundaries should be “flagged” in RED and system numbers should be clearly marked at regular intervals on the respective line-work and equipment.

System summary sheets should be prepared which list the system content by line and equipment numbers.

Detailed Pre-Commissioning / Commissioning Execution Plan

A plan is developed that identifies all of the major pre-commissioning activities by system. The plan will be developed in reverse and will clearly identify “system ready for pre-commissioning” milestones. Commencement of system turnover from construction to commissioning should ideally commence at approximately 70% erection completion. From this point handover of systems should be made on a regular basis. Safety is impaired when there is a period of low activity followed by a period of high activity to achieve target-pre-commissioning progress.

A method of pre-commissioning progress monitoring will be developed to allow progress to be monitored by:

- Overall pre-commissioning completion for the complex
- Pre-commissioning completion by Process Unit
- Pre-commissioning completion by system
- Discipline completion by system
- Vendor Schedule.

A vendor schedule will be developed that identifies vendor requirements for each item of equipment. Supporting documentation will provide information on required vendor activities, support required and approximate duration of each major activity.

Generic Method Statements

Generic method statements is developed for each activity type (Cleaning, Leak Test, Inerting, etc.). Each statement will form the basis for the development of safe and efficient detailed procedures. The method statements will contain information on the methodology, acceptance criteria and HSE implications.

Commissioning Plan and Critical Path Network

A network is developed those indexes and identifies all start up activities.

Parallel and consecutive activities will be identified. Each activity will have an expected duration and will logically link into the next related activity.

Each activity will have a summary sheet to identify in checklist format the necessary actions to be undertaken to achieve the completion of the activity.

A strategy will be developed to achieve the following requirements within the agreed contractual milestones.

Organisation Roles And Responsibilities

The Commissioning Organisation will consist of an integrated Company, PMC and EPC team. The organisation will change as commissioning progresses from design, through Pre-Commissioning and start-up activities. This evolution will be managed through regular reviews of the relevance of the commissioning organisation structure to that stage of progress.

Punch-Listing Method Statement

A system will be developed to identify (see TMSCOM® Para.), record and correct damaged, incomplete and incorrect installation and/or fabrication. Items which are inaccessible or unsafe will be incorporated into this system. The system will be able to allow categorisation of punch-list items as follows:

- | | |
|-------------------|--|
| Category A | Items that must be cleared prior to start of Pre-commissioning |
| Category B | Items that can be cleared during pre-commissioning |
| Category C | Commissioning Items |

The system will be able to track outstanding items by system, category and discipline.

Commissioning input to the Design Process

Input of commissioning experience to the design process will ensure that:

- Commissioning and operating safety is addressed in the design
- All phases of the initial start-up (Including one-off special procedures) are adequately covered in the design specifically including definition of systems and system turnover sequence
- Consideration has been given to the pre-commissioning of the process units
- To achieve this commissioning group representatives will attend and provide input at P&ID reviews, HAZOP Reviews and Model Reviews: They will also review cause and effect diagrams and spare parts orders.

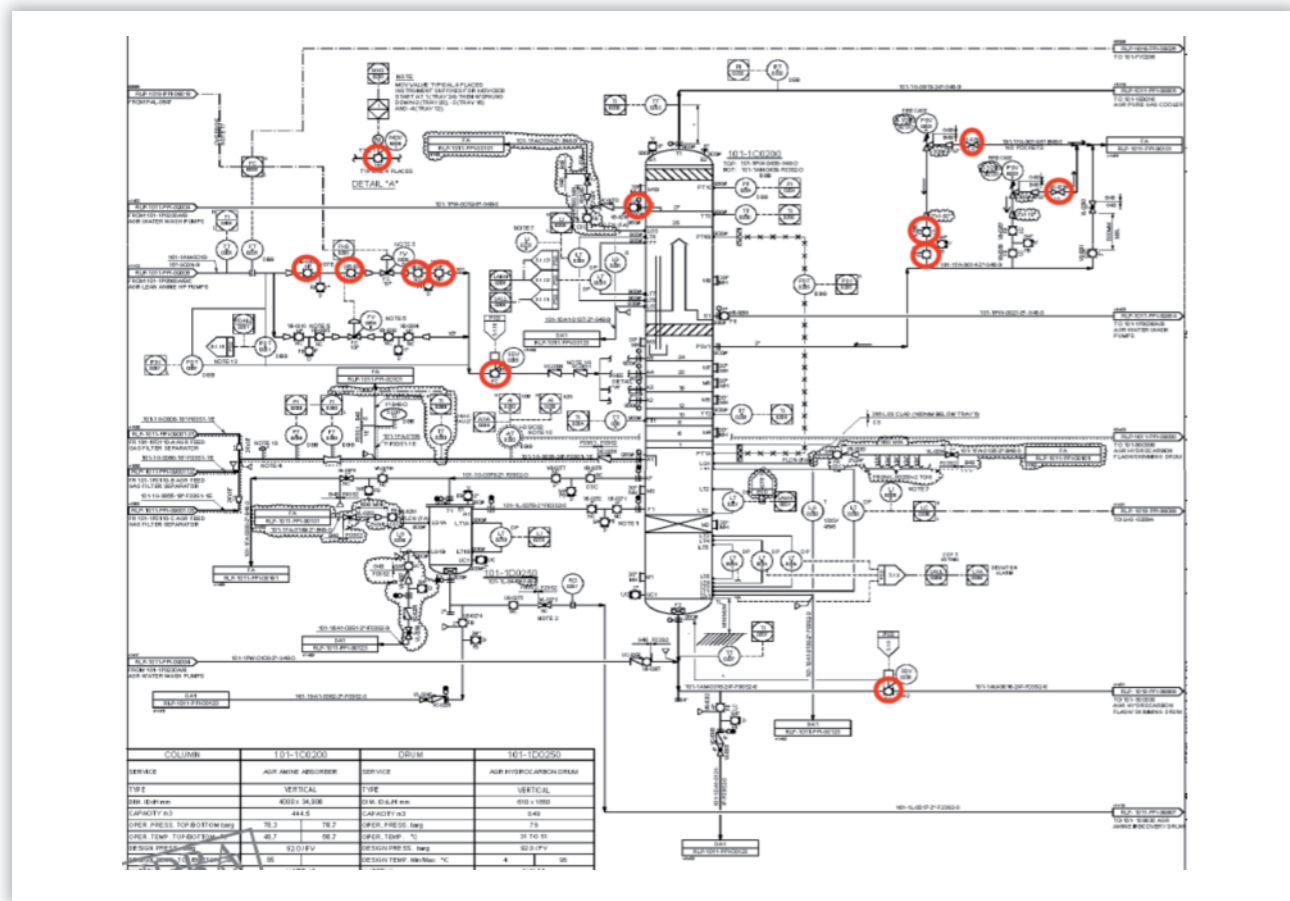

Commissioning Spare Parts & Consumables

A commissioning Spare Part list will be developed by checking the individual equipment requirements. Using the detailed pre-commissioning procedures as a basis, a list of consumables will be generated to allow preparation and reinstatement of all systems. Particular attention will be paid to spool, dummy spool and gasket requirements.

Sample and Testing Schedule

Stream sample and testing schedules will be developed which addressed licensor and Client requirements. One schedule will be developed to cover the initial start-up phase, one to cover the test run period and one to cover normal on-going operation of all process units. Requirements will be developed for each case indicating the stream reference, frequency requirement and test requirement.

2.2.2 (Pre-)Commissioning and Start-up Manuals

2.2.2.1 Pre-commissioning and Commissioning Manuals

Pre-commissioning and Commissioning manuals will be supplied as a collection of pre-commissioning procedures; these procedures are operating instructions for the activities to be carried out during the performing of pre-commissioning and commissioning activities.

The main list of the procedures to be carried out is:

- Mechanical Preparation
- Chemical Cleaning Instructions
- Physical Cleaning Instructions
- Mechanical Restoration
- Machinery Run in
- Tightness test
- Electrical testing/functional tests/energizing
- Instruments calibration and functional test
- Loading of chemicals
- Loading of catalyst
- Heaters drying
- Chemicals boil out of steam generation facilities
- Verification of Mechanical Completion
- ...

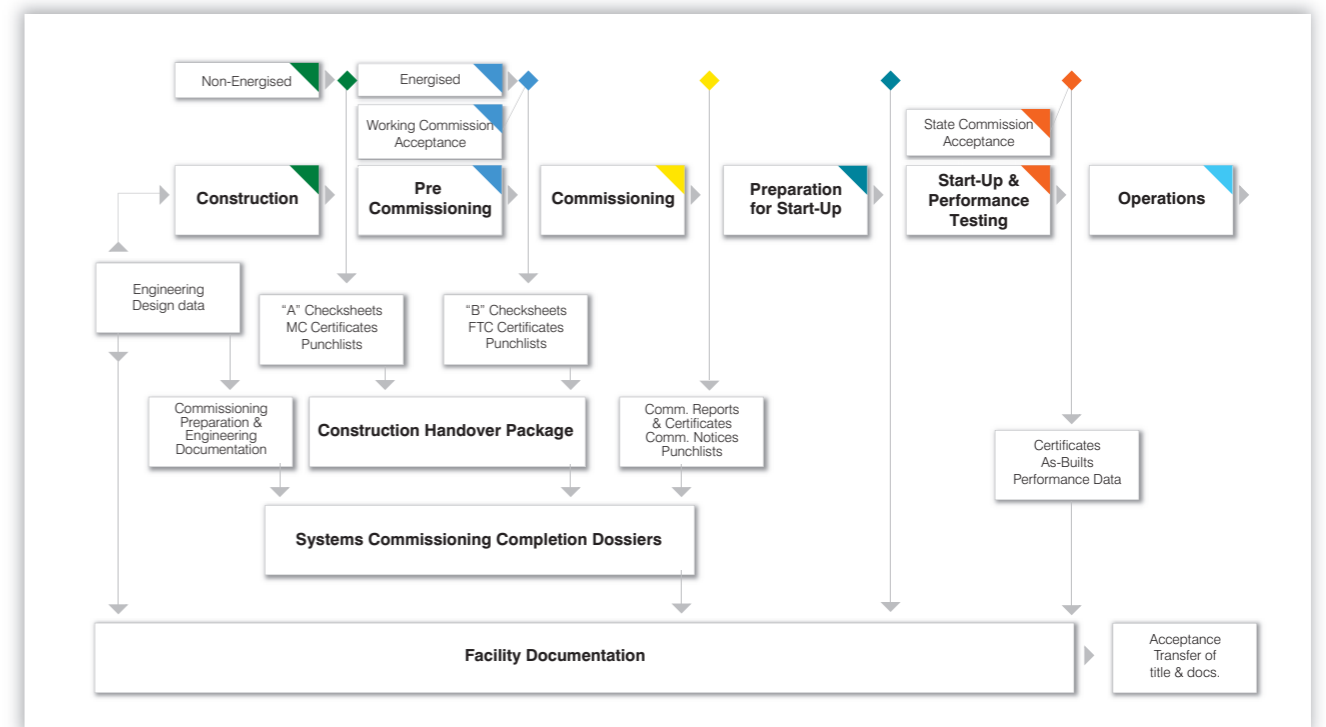



2.2.2.2 The Start-Up Procedures

Start-up Procedures will be prepared; **ISS International** can develop also, for each Process Unit, a detailed Operating Manual.

A general index for plant operating manual is shown below.

Operating Manual General Index

1. INTRODUCTION
 - 1.1 General
2. BASIS OF DESIGN
 - 2.1 Duty of plant
 - 2.2 Environmental conditions
 - 2.3 Feedstock and product specifications
 - 2.4 Battery limit conditions
 - 2.5 Specifications and consumptions of utilities, chemicals and catalysts
3. PROCESS DESCRIPTION
 - 3.1 Process theory
 - 3.2 Description of flow
 - 3.3 Process variables
4. PREPARATION FOR INITIAL STARTUP
 - 4.1 General
 - 4.2 Plant inspection
 - 4.3 Cleaning of piping and equipment
 - 4.4 Specific pre-startup operations

5. STARTUP PROCEDURE
(for each configuration)
6. NORMAL OPERATION
7. NORMAL SHUTDOWN PROCEDURE
8. EMERGENCY SHUTDOWN PROCEDURE
9. ANALYTICAL REQUIREMENTS
10. ATTACHMENTS

Note:

Start-up and shut-down procedure will include detailed equipment procedure. Systems will be divided into "main equipment", such as turbines, special motors, etc., and "common equipment". For each Main Equipment will be developed a specific "TAG" procedure while for the "common equipment", such a centrifugal pumps, exchangers, etc, will be developed a typical equipment configuration procedure non referred to a specific TAG.

2.2.2.3 Safety Manual/Quality Manual

A recommended general index for plant safety manuals is shown below.

The index consist of section titles (one digit numbering) and paragraph titles (two digits numbering). Sub paragraph titles exceeding two digits do not appear in the general index. A detailed section index listing all subparagraphs titles is given before each section of the manual.

1. INTRODUCTION
 - 1.1 General
2. PRE-COMMISSIONING AND COMMISSIONING EMERGENCY PROCEDURES
 - 2.1 Emergency Contact Numbers
3. GENERAL SITE HAZARD
 - 3.1 Pressure Testing and Air Freeing of Process Plant on Site
 - 3.2 Safety in Plant Commissioning
 - 3.3 General Fire Protection and Prevention
4. PROTECTIVE CLOTHING AND EQUIPMENT
 - 4.1 Respiratory Protective Equipment
 - 4.2 Compressed Air Breathing Apparatus
 - 4.3 Escape Filter
5. PRE-COMMISSIONING AND COMMISSIONING SAFETY TRAINING
 - 5.1 Safety Training Concept
 - 5.2 Training Modules Common to Pre-Commissioning and Commissioning Activities
 - 5.3 Safety Training Modules Content

6. PERMIT TO WORK PROCEDURE
 - 6.1 Lockout and Tagging
 - 6.2 Working Inside Energized Buildings
 - 6.3 Vessels/Confined Space Entry
7. PROJECT SAFETY FORMS
 - 7.1 Permits to Work
 - 7.2 Lockout/Tagging
 - 7.3 General
8. SAFETY CONCEPTS
 - 8.1 General
 - 8.2 Codes and Standards
 - 8.3 Climatic Condition
 - 8.4 Hazardous Area Classification
 - 8.5 Fire Protection
 - 8.6 Personal Protection
 - 8.7 Fire and Safety Point Shelters
 - 8.8 Fire & Gas Detection
 - 8.9 Fire Proofing
9. GENERAL INFORMATION
 - 9.1 Fire Water Network - Overview
 - 9.2 Deluge System - Overview
 - 9.3 Inert Gas System – Overview
 - 9.4 Fire Equipment – Overview
10. MATERIAL SAFETY DATA SHEETS



2.3 THE SITE PHASE

During this phase an integrated organisation performs all of the activities addressed in Home Office phase. The activities will be monitored and witnessed as necessary by relevant parties. All activities and reporting should be system based and fulfil the requirements of the respective acceptance criteria. The site phase can further be separated into the main periods:

a. Mechanical Completion Verification & Interim Handover

b. The Pre-Commissioning Period

- System turnover
- Plant cleaning
- Punch-Listing
- Leak testing
- Inerting
-
- Pre-Commissioning complete.

c. The Commissioning & Start-Up Period

- Ready for Commissioning
- Commissioning critical path
- Start-up procedure
- Licensor/Vendor support
- Conduct and supervise all activities during the Introduction of Feedstock to the Units
- Stabilize the Unit
- Conduct Performance Test Run.

2.3.1 Mechanical Completion Check & Interim Handover

Immediately prior to the hydrotest of each system, a Punch-List will be performed by an integrated Punch-List team consisting of construction, and EPC Commissioning Engineers (from relevant disciplines).

When all "A" type items have been cleared and a small but manageable amount of "B" type items are left, a handover can be progressed from the construction to the commissioning group. Since mechanical completion has been achieved with agreed exception items, it is classed as an interim handover to permit construction completion and Pre-Commissioning activities simultaneously. Control and responsibility of work on the system rest with the commissioning group. Any construction work will require written permission from the Lead-commissioning Engineer of the particular Process Unit. Permission will be granted on a job by job basis.

This would involve a line-by-line detailed check of the actual physical installation against the latest P&I diagrams issue, job specifications, piping hanger and support drawings, vendor drawing, etc., for erection of the unit in accordance with all drawings and applicable specification. The systems would also be checked from an operating viewpoint for proper location and orientation of valves, vents, drains, steam tracing and traps, sample connections, etc. Punch lists of deviations, installation errors, missing items, etc., shall be prepared and given to the appropriate construction department for correction or completion. Also included in this inspection and check-out would be:

Vessel Internals - This would include going through each tower and vessel to check the installation of trays, baffles, demisters, spargers, etc., and verifying that the dimensions of all weirs, downcomers, distributors, thermowells, etc., are within specification and are properly oriented, as well assuring the internal cleanliness of each vessel prior to final closure.

Non-operating Adjustments - All non-operating adjustments, packing of pumps and valves and cold alignment of equipment performed by the construction subcontractors should be spot-checked, witnessed or periodically inspected to ensure proper records are being kept and recorded for turn over.

Piping - Check lists would be prepared on each hydrostatic test system before the system is released for hydrostatic testing. Completion of this punch lists by the construction contractor would be required before the test system is released for testing. Post-hydro punch lists would be prepared and followed through on to ensure that the systems were fully completed and ready for pre-commissioning.

Electrical Installation - Each electrical circuit and motor installation and their electrical polarity check and insulation resistance measurement would be demonstrated by electrical subcontractor to the Commissioning Subcontractor Team.

Instrument Installation - Review of instrument installation of correctness according to the instrument drawings and specification. The Commissioning Subcontractor Team would witness and/or approve all instrument calibration and check out procedures or work performed by instrument subcontractor.

System Pressure Testing - Although the construction contractor is responsible for the actual pressure testing of each system prior to mechanical completion, the

Commissioning Subcontractor Team would review the test program and the methods used to ensure satisfactory tightness.

2.3.2 Pre-Commissioning Period

The site phase of the project will commence at approximately 60% construction completion and activities will be mainly centred on:

- Progression of all of the procedures developed during the Home office phase of the project
- Co-ordinating system turnover and completion
- Monitoring and reporting progress
- Co-ordinating resources, including sub-contract and vendor support
- Liaising with licensors.

Main activities developed during Pre-Commissioning phase are:

Punch-Listing

Punch-Listing will be undertaken on a systems basis. An integrated team will be formed to participate in Punch-Listing. An initial Punch-List will be undertaken immediately prior to system handover for Pre-Commissioning purpose. This will probably occur at around the hydrotest time. Punch-List items generated at this stage will be incorporated into the Project master Punch-List system. A final Punch-List will be undertaken by system immediately prior to the commencement of commissioning activities. This will be a less stringent Punch-List and aimed at checking the system over before introducing hydrocarbons. Utilisation of the Pre-Commissioning check sheets will assist in completing a full range of required checks. Punch-Listing progress will be recorded on an A3 set of P&IDs.



System Cleaning

This would include directing the cleaning of systems either by flushing, blowing or chemical cleaning by issuing directives for the necessary temporary connections, utilities and proper line up of the system to be cleaned. When the services of a chemical cleaning subcontractor are required, the Commissioning Team will monitor his performance to ensure a satisfactory cleaning job. Before each system is closed for operating, the lines and equipment would be inspected for cleanliness. Cleaning progress will be recorded on an A3 set of P&IDs.

Equipment Run-In

This would include planning and co-ordinating Vendor representatives for the running in of the equipment and obtaining the necessary utilities to accomplish the run-in for equipment such as blowers, pumps, compressor, motors, turbines, and other machinery or mechanical equipment without process fluids before start-up.

Vessel Loading

This phase would ensure that all catalysts, packing, resins and desiccant loading is performed in a proper manner and accurate records and samples of each material loaded are retained.

When all the activities foreseen in the Pre-Commissioning phase (the Process Units will be ready to receive hydrocarbons, most of the utility systems will be live to the respective units and all of the hydrocarbon lines will be positively isolated at the unit battery limits) have been performed successfully a Ready for Commissioning Certificate will be issued and so Commissioning activities can start.

2.3.3 Commissioning & Start-Up Period

Once the unit is precommissioned, the Commissioning Team will conduct the following main activities:

- Purging
- Leak Test / Tightness Test
- Spring Hanger Check
- ...

to start with initial Start-up operations assuring that every activity is accomplished smoothly and safely.

The Commissioning Subcontractor Team would take care in troubleshooting any operating or process problems, should they arise, and would investigate any operating deviations as they occur. Team will:

a. Develop and Review Specific Operating Instruction

The procedures and practices outlined in each unit's operating manual will be followed. As these manuals cannot cover every conceivable operating situation, it will be necessary to develop specific operating instructions to cover critical areas of operating as they arise. Any additional operating procedures and practices will be given either in writing, if time permits, or verbally, if immediate action is required, to operating supervisors. An operating logbook will be kept in order to record the instructions and relevant changes in the operating conditions.

b. Conduct and supervise all activities during the Introduction of Feedstock to the Units

Licensors' process and operation specialists will be present for providing advice during the critical first start-up from a technical point of view and will help troubleshoot any problems that arise or investigate any deviations that occur. The Commissioning team will monitor the plant operations and make any operating changes for stable, efficient operation.

c. Stabilize the Unit

The Commissioning Team will provide to work with process licensors (if required) on how to bring the units on stream and up to design rate. Control variables and flow rates will be specified to stabilize the unit at design rate in preparation for the acceptance test and during the performance test.

d. Conduct Performance Test Run

The Commissioning Team will pompon the procedures guarantee and documentation and witnesses the instrument calibration. During the execution of Performance Test the Initial Operation Team will conduct the plant according to the procedure already agreed between the **ISS International** and the Client.

2.4 SYSTEM TURNOVER MANAGEMENT

System Handling

Construction will progress from a "bulk-area" completion basis to a "system" basis approximately 60% through the erection programme. It will be essential to control and co-ordinate the temporary and permanent transfer of systems from one group to another to progress construction completion, Pre-Commissioning and commissioning work. A Systems Co-ordinator will provide the necessary link between construction and commissioning. The co-ordinator will be responsible for developing system completion strategies on a daily basis to ensure a smooth handover process.

Each system will have a turnover package of commissioning dossier associated with it. A co-ordination procedure will be utilised for the "offering" or "receiving" of systems. At the schedule date for system turnover, the construction group will compile diagrams, equipment list, instrument lists, exception lists, inspection reports and other QA/QC documentation for that system.

The routing of each system will be from the construction group to the commissioning group. The commissioning group will have an internal handover mechanism to recognise the importance of introducing hydrocarbons to a process unit for the first time.

Pre-Commissioning Complete

When the Pre-Commissioning work on each utility system is complete it can then be commissioned providing it is safe to do so. For non-utility systems the point at which the process Unit is considered to be "ready for Start-up" is when all non-hydrocarbon systems have been pre-commissioned. At this stage the Unit is presented as "Ready for Commissioning" This triggers several safety activities as follows:

- A final Punch-List to determine if the unit is ready to accept hydrocarbons
- A pre-start up safety review
- The introduction of a full permit to work and safety system.

Commissioning Complete

When all commissioning for a process unit is completed the unit is declared "Ready to Start-up". At this point normal conditions are established to produce the designed products.



CHAPTER
3

Dedicated Tool

In order to control the commissioning activities that should be integrated with the construction activities, **ISS International** has been developed an In-House software: **TMSCOM®** (Turnover Management System for Commissioning).



The purpose of the Plant turnover Management System is to provide the appropriate tool to follow the **ISS International** policies, procedures and quality (QA/QC) checks, in order to administrate all the documentation and to control the Turnover of the facilities from ISS International to its Client / the Owner. **ISS International** has developed the above mentioned tool that allows the turnover engineer to follow

construction, Pre-Commissioning and commissioning activities from the plant's area definition up to the final hand-over of the plant reducing time and costs related to this kind of activities given a time by time progress. The **TMSCOM®** is a modular and tailored tool that allow more then 10 users to access together into the system for on-line up-date and view using a normal TCP/IP network.

It shall be the direct link between Construction and Commissioning activities.

In details, the **TMSCOM®** allows to:

- Manage QA/QC certificates
- Manage Construction piping activities
- Manage Construction electrical activities
- Manage Construction instrument activities
- Manage Construction machinery activities
- Manage Construction punch lists
- Have Construction progress per area
- Have Construction overview progress
- Have day by day reports
- Manage the transaction between construction and commissioning activities
- Manage pre-commissioning activities based on construction progress
- Manage punch list outstanding items
- Manage pre-commissioning and commissioning punch list
- Manage Turnover progress and certificates

- Manage mechanical completion progress, certificates and activities
- Manage ready for commissioning turnover progress, certificates and activities
- Manage performance test turnover progress, certificates and activities
- Manage provisional acceptance turnover progress, certificates and activities.

System Flow Chart

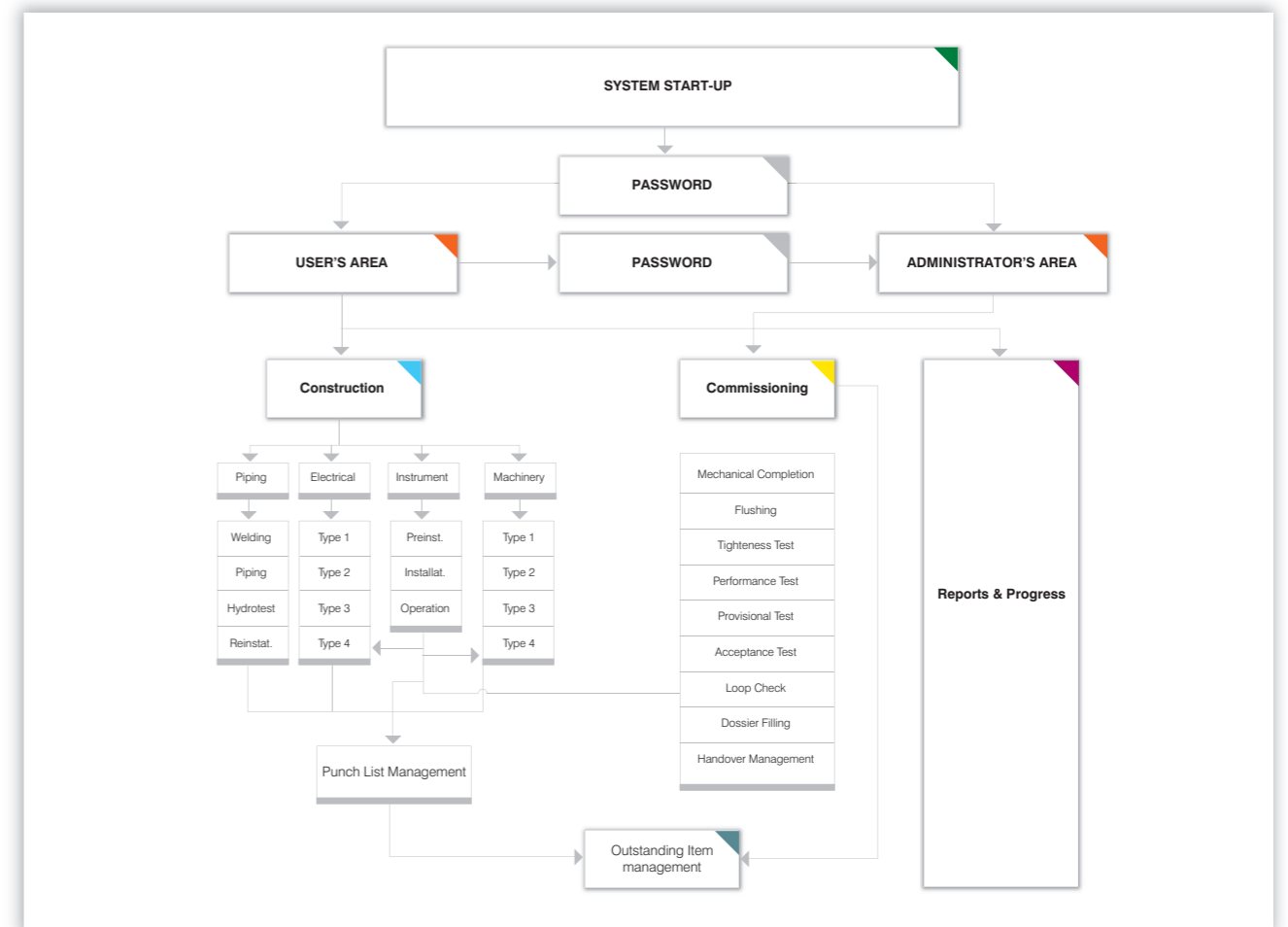



System Details Pictures

Main Password



Main Menu



Punch List



Discipline Tag Main Menu



TAG Mng System

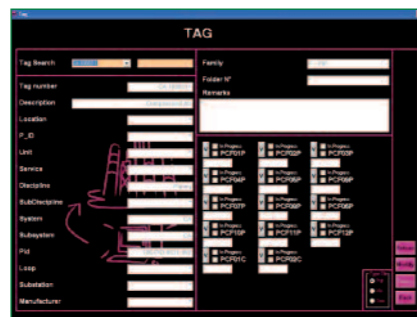

Plant System Mng

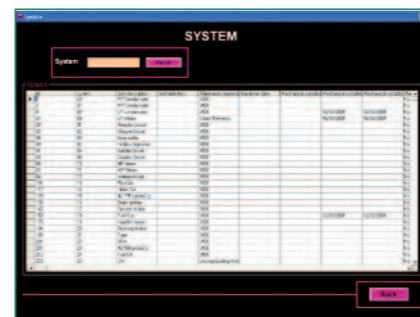

ISS International/Main/Final Clients

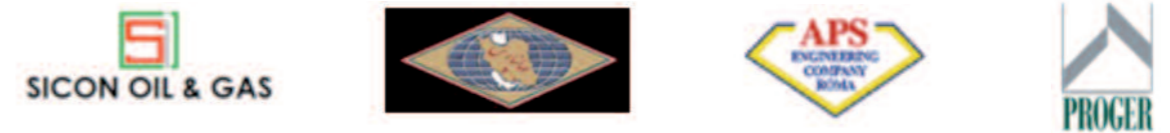

To see our Partner network, visit our web site: www.iss-international.it at the Reference Clients section

WE GLOBALIZE
JUST FOR YOUR BUSINESS



ISS International SpA

Headquarters

Via Magna Grecia, 117 - 00183 Rome, Italy

Phone: +39 06 4522821

Fax: +39 06 45200351

www.iss-international.it



ISS International SpA - Training Center

Via Magna Grecia, 117 - 00183 Rome, Italy

ISS International is certified:

ISO 9001 EA35

ISO 9001 EA37

ISO 14001

OHSAS 18001



The present document is property of ISS International SpA and shall not be totally or partially, directly or indirectly, transferred, reproduced, copied, disclosed or used, without the authorization of ISS International SpA.