

Complete and robust mechanical simulation solution

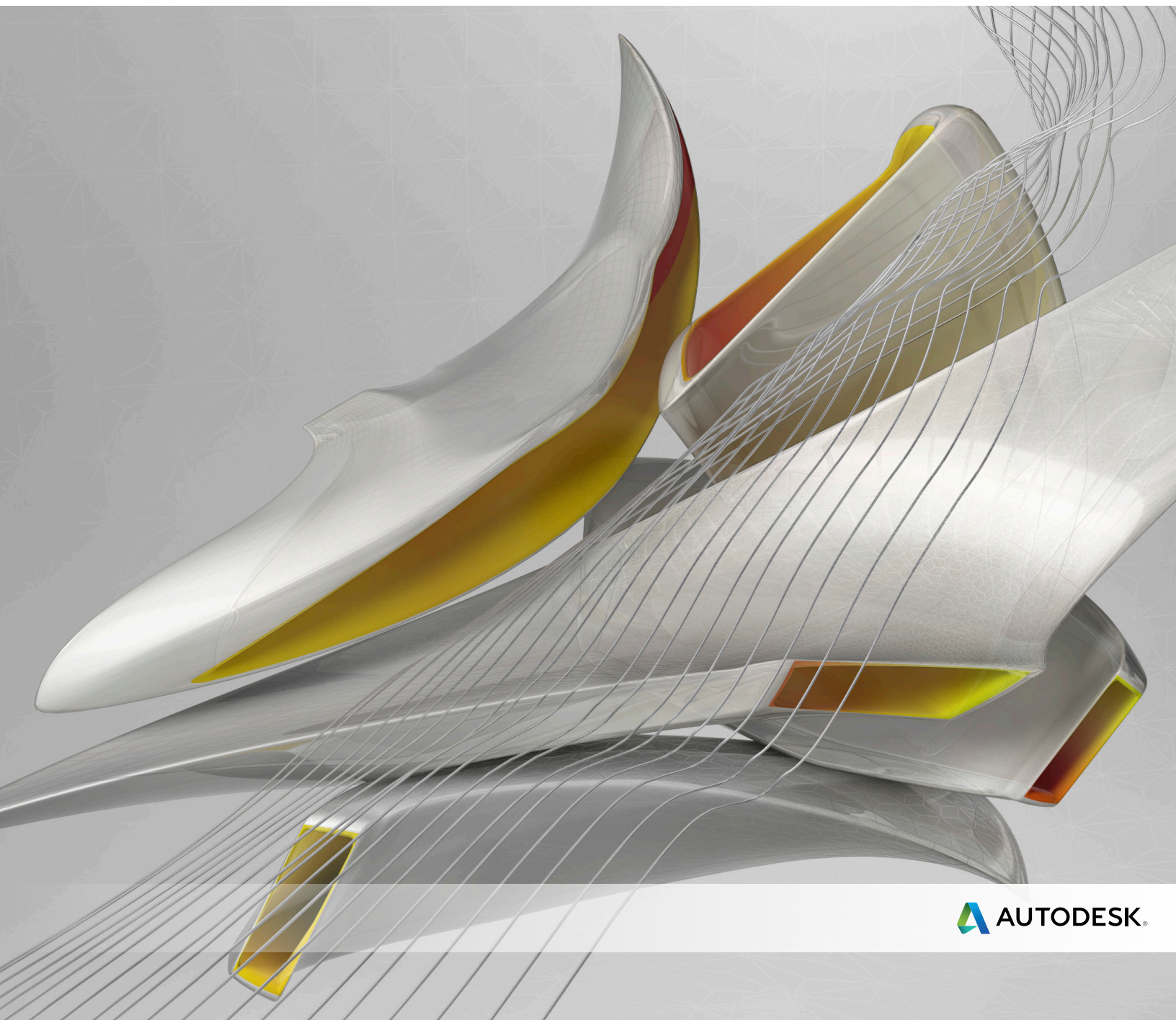

A mechanical simulation solution for finite element analysis powered by the Autodesk Nastran solver

imaginii.com/simulation

Accurately predict product behavior, optimize designs, and validate digital prototypes with a wide range of mechanical simulation capabilities before manufacturing

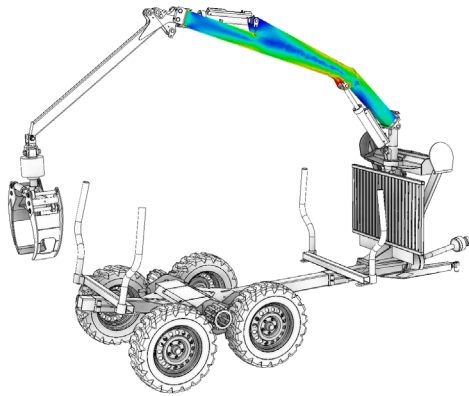

Autodesk® Simulation Mechanical software, powered by Autodesk® Nastran®, provides a wide range of accurate mechanical simulation capabilities to help you predict product performance, optimize designs, and validate product behavior before manufacturing.

Autodesk Simulation Mechanical enables users to utilize a highly accurate, industry-tested, general-purpose finite element solver to run comprehensive multiphysics simulations with other Autodesk products. Supporting multi-CAD environments, Simulation Mechanical provides flexibility in simulating CAD models in various formats. Integrated with the comprehensive Digital Prototyping solution offered by Autodesk, Simulation Mechanical brings finite element analysis (FEA) to all designers, engineers, and analysts to help them make great products.

A complete mechanical simulation solution

Autodesk Simulation Mechanical is a stand-alone FEA mechanical simulation solution that provides a complete offering of capabilities, such as:

- **A wide range of analysis capabilities:** Delivers a broad range of analysis capabilities that enable designers, engineers, and analysts to bring product performance knowledge into the design cycle, helping them to improve collaboration, design better and safer products, save time, and reduce costs.
- **Easy-to-use interface:** Connects with many CAD solutions, making it easy to set up simulations and produce desired results and generate reports.
- **Robust solver technology:** Provides more accurate results through advanced analysis using the industry-trusted Autodesk Nastran solver.
- **Extensive material model library:** Utilizes a wide range of element and material model options and a customizable database of more than 8,000 available materials.

- **Multi-CAD modeling:** Imports and evaluates a range of potential designs from Autodesk® AutoCAD®, and Autodesk® Inventor® software, SolidWorks®, PTC® Creo® and Pro/ENGINEER®, Rhinoceros®, CATIA®, SpaceClaim®, Siemens® NX, Parasolid®, and JT files, ACIS, IGES, and STEP.
- **Autodesk SimStudio Tools:** SimStudio Tools allow you to quickly edit your geometry for simulation. It reads in multiple CAD file formats and enables you to quickly simplify models, eliminate unnecessary detail, perform basic repair, or easily make design changes so you can explore various design ideas faster.
- **Multiphysics simulations:** Provides multiphysics simulation, such as thermal-electric and fluid-structural, and the ability to simulate as-manufactured material properties for injection-molded parts.
- **Flexible cloud solving:** Offers flexible solving options that enable you to leverage the cloud or local resources for solving multiple simulations simultaneously.
- **Autodesk product integrations:** Integrates with Autodesk's portfolio of products, such as design, simulation, visualization, and data management solutions.

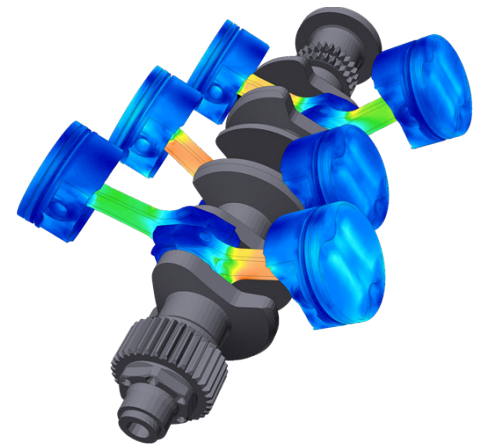
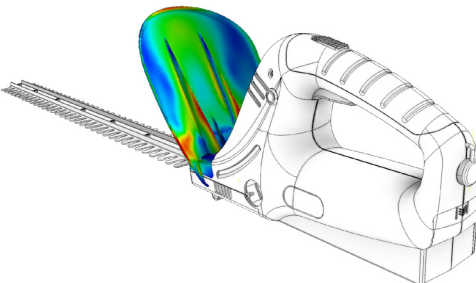
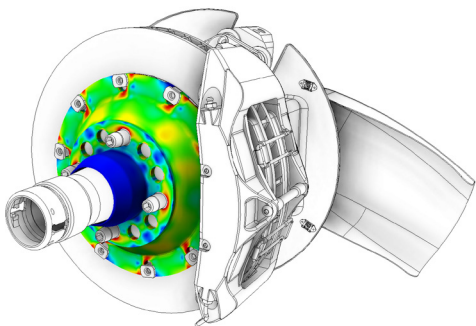

Image courtesy of ADEPT Airmotive (Pty) Ltd.

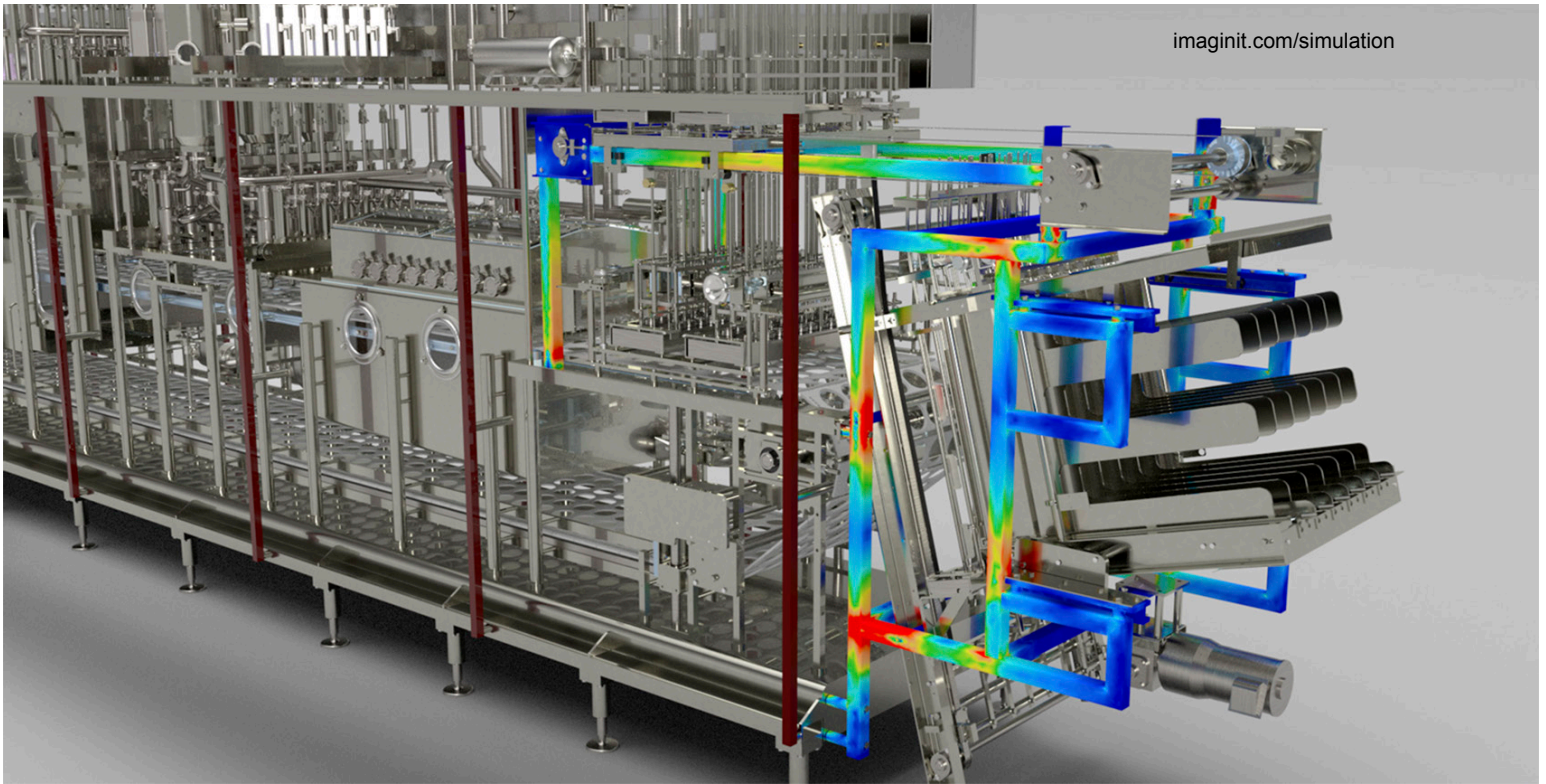

Image courtesy of Osgood Industries, Inc.

Facing these challenges?

- Engineers and analysts need to make accurate design decisions without building multiple physical prototypes.
- Confidence in simulation results is required before investing resources in design changes or new products.
- Product designs include a wide range of materials—not just common metals.
- Motion and the combination of multiple physical effects are critical design considerations.
- Product design teams need to perform simulation on geometry from multiple CAD software tools.
- Field failures need to be avoided; must determine durability of structures under repeated loading.
- Design and manufacture of models need to be optimized.

Benefits of Autodesk Simulation Mechanical

Perform accurate simulations efficiently

Simulation enables critical engineering decisions to be made earlier in the design process. With Autodesk Simulation Mechanical, part of the Autodesk solution for Digital Prototyping, engineers and analysts can have a simulation solution that allows them to study initial design intent more easily, and then more accurately predict the performance of a complete digital prototype.

When working with CAD geometry, automatic meshing tools produce high-quality elements on the first pass—ensuring simulation accuracy within the areas of greatest engineering concern, and helping to predict product performance in less time. Built-in modeling capabilities enable designers, engineers, and analysts to edit the mesh directly to help with the accurate placement of loads and constraints or to create simplified geometry for proof-of-concept studies. In addition to increasing productivity through modeling flexibility, designers, engineers, and analysts can quickly validate concepts before resources are invested in significant design changes or new products.

Learn more about your product's performance

Through easy-to-use tools, extensive CAD support, and proven technology, Autodesk Simulation Mechanical software helps you predict the real-

world performance of products. Design validation and optimization through extensive engineering simulation helps you bring better products to market faster—and at less cost.

Simulate more, reduce errors, and optimize designs

Necessary design changes become more apparent when a product's real-world environment is fully simulated, but computationally intensive analyses can be both time- and resource-intensive. Robust solvers in Autodesk Simulation Mechanical software utilize the power of all available computing resources for local or cloud solves, enabling designers, engineers, and analysts to study more realistic digital prototypes in a practical amount of time.

Easily expand engineering simulation capabilities

Decisions to integrate engineering simulation further into the design process often leads to unexpected costs and delays to retrain the product design team. By providing an entire range of validation and optimization tools within the same easy-to-use interface, Autodesk Simulation Mechanical software enables designers, engineers, and analysts to start with mainstream tools and then expand their toolkit to include more advanced analysis, such as mechanical event simulation (MES), without the need to learn new workflows.

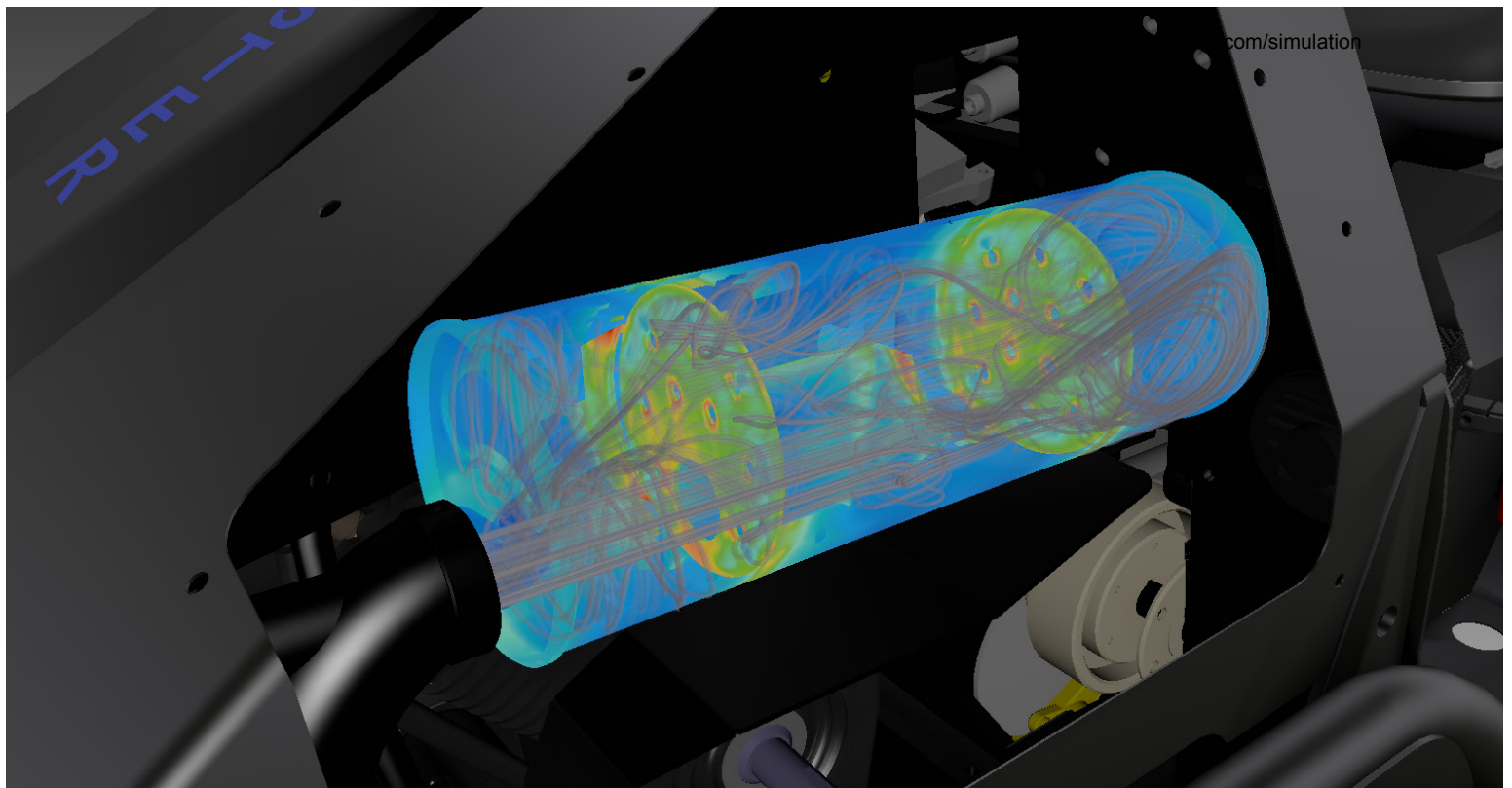

Powered by Autodesk Nastran

Autodesk Nastran is an industry-recognized, general purpose FEA solver known for its accuracy in analyzing linear and nonlinear stress, dynamics, and heat transfer characteristics of structures and mechanical components. Autodesk Nastran also offers an editor for real-time results and changes in solution parameters while solving—enabling users to identify and fix issues earlier in simulations. This high-end simulation technology is included with Simulation Mechanical so you can obtain more accurate results for complex simulations.

A wide range of material models

Support for a wide range of linear and nonlinear materials allows for better understanding of the real-world behavior of products. Whatever materials are included in a design, from metal to rubber, material data is vital to the accuracy of an engineering simulation—allowing designers and engineers to learn more about how a product will perform or even how it might fail.

Combine multiple physical effects in advanced simulations

Real-world product behavior is often the result of multiple physical effects interacting simultaneously. Advanced simulation setup is made easier through the use of standard engineering terminology, visual process guidance, and user-friendly tools and wizards that automate the transfer of simulation results between multiple analyses—focusing designers, engineers, and analysts on product performance, rather than advanced numerical or simulation methods.

Collaborate in a multi-CAD environment

Manufacturers often create and share designs in multiple CAD software tools, making it difficult to integrate engineering simulation tools into an existing design process without requiring significant and costly changes. Autodesk Simulation Mechanical software supports efficient workflows in today's multi-CAD environment by providing direct geometry exchange and full associativity with Autodesk Inventor, SolidWorks, Pro/ENGINEER, PTC Creo, and other software.

Flexible cloud solving capabilities

Autodesk Simulation Mechanical also delivers flexible cloud computing capabilities available in Autodesk® Simulation Flex offerings. Autodesk Simulation Flex provides cloud-enabled and local machine solving options for comprehensive and multiple simulations.

Flexible solving options enable you to simulate where and how you want, based on your needs. If you are setting up an analysis, use your local resources to iterate and optimize your inputs. When you are ready to kick off a longer, more computationally intensive simulation, use the power of the cloud and free up your local resources for other tasks.

Autodesk's complete portfolio of simulation products

Autodesk Simulation Mechanical is part of the mechanical simulation offerings from Autodesk, which are all powered by the Autodesk Nastran solver. Autodesk Nastran is an industry-recognized FEA solver that delivers accurate results to complex simulations. Autodesk® Nastran® In-CAD™ software delivers CAD-embedded FEA simulation. Autodesk Simulation Mechanical is a complete mechanical simulation solution that accurately predicts product performance, optimizes designs, and validates product behavior before manufacturing.

Autodesk also offers additional simulation products to help you predict product performance further by optimizing and validating your designs. The Autodesk® Simulation family of products and the Digital Prototyping solution from Autodesk enable you to integrate mechanical, structural, fluid flow, thermal, composite, and plastic injection molding simulation tools into your product development process to help reduce costs and speed time to market. Autodesk provides a range of flexible solutions that enable you to solve locally or in the cloud, to help you increase your productivity.

A wide range of analysis capabilities

imaginitt.com/simulation

Linear

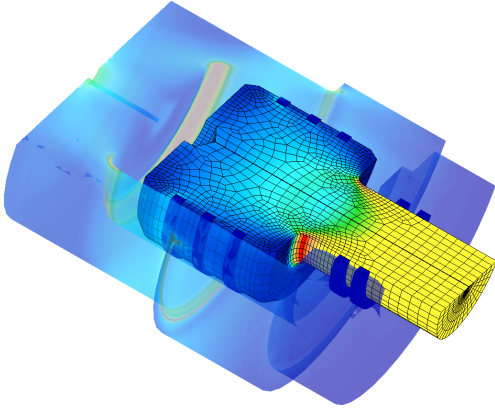

Linear analyses follow these basic assumptions:

- Loading causes only small deflections or rotations
- Change in direction of loading due to deformation is small and can be neglected
- Materials are linear within elastic region on stress-strain curve
- Boundary conditions do not change

Static Stress with Linear Material Models

- Calculate displacements and stresses due to static loads
- Although contact is a nonlinear effect, it can be included in a static stress analysis (solution becomes iterative)

Natural Frequency (Modal)

- Calculate natural frequencies and mode shapes of model due to purely geometric and material properties

Natural Frequency with Load Stiffening

- Axial compressive or tensile loads affect the frequency of system

Response Spectrum

- Calculate maximum displacements and stresses due to spectrum-type load

Random Vibration

- Calculate statistical response of a system due to random vibration, white noise, or power spectrum density

Frequency Response

- Calculate steady-state response due to harmonic or sinusoidal load or acceleration

Transient Stress (Direct Integration or Modal Superposition)

- Calculate displacements and stresses over time due to loads that vary in a known fashion
- Inertial effects are included

Critical Buckling Load

- Calculate loads that cause model to buckle due to geometric instability
- No inertial effects

Dynamic Design Analysis Method (DDAM)

- Use to calculate maximum displacements and stresses due to spectrum-type load
- Use when designing naval equipment or vessels

Nonlinear

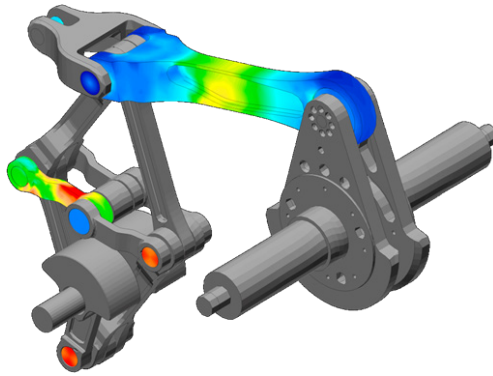

Assumptions listed for linear analyses are not limitations when doing a nonlinear analysis. Nonlinear analyses permit the following:

- Loading can cause large deflections and/or rotations
- Rigid body motion and/or rotations are accounted for
- Loading can change in direction due to deformation
- Materials can be nonlinear (either elastic or plastic)
- Boundary conditions can change over time in a known fashion

MES (Mechanical Event Simulation) with Nonlinear Material Models

- Calculate displacements, velocities, accelerations, and stresses over time due to dynamic loads
- Loads can be constant, vary over time, or vary based on calculated results
- Inertial effects are included

Static Stress with Nonlinear Material Models

- Calculate displacements and stresses due to static loads
- Loads can be constant, vary between time steps or load cases, or vary based on calculated results
- Inertial effects are ignored

Natural Frequency (Modal) with Nonlinear Material Models

- Calculate natural frequencies and mode shapes of model
- Change in frequency due to displacements or changing material properties is not included

- Loads do not affect frequencies
- Boundary conditions are fixed

MES Riks Analysis

- Calculate displacements and stresses before and after model has buckled or collapsed
- Inertial effects are ignored

Thermal

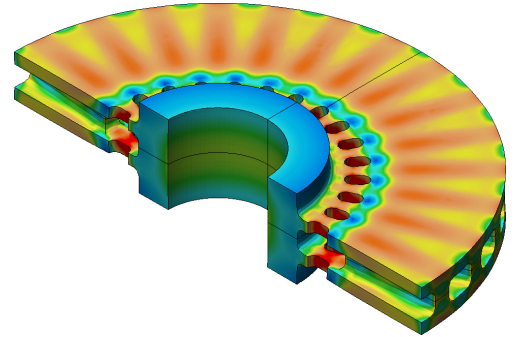

Steady-State Heat Transfer

- Calculate temperature and heat fluxes after an infinite period
- Thermal loads are constant over time

Transient Heat Transfer

- Calculate temperature and heat fluxes over time due to thermal loads
- Thermal loads can be constant or change over time
- Material can change states between solid and liquid

Electrostatic

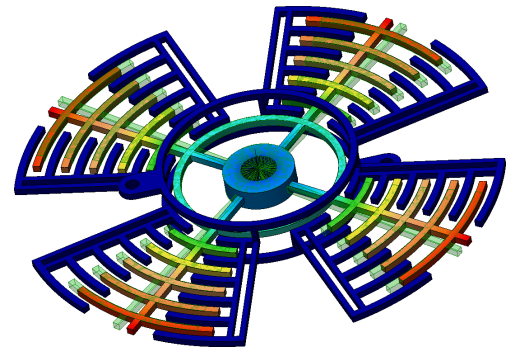

Electrostatic Current and Voltage

- Calculate current and voltage distribution after an infinite period due to induced voltages and current sources

Electrostatic Field Strength and Voltage

- Calculate electric field and voltage distribution after an infinite period in an insulator due to induced voltages and charges

Autodesk Digital Prototyping is an innovative way for you to explore your ideas before they're even built. It's a way for team members to collaborate across disciplines. And it's a way for individuals and companies of all sizes to get great products into market faster than ever before. From concept through design, manufacturing, marketing, and beyond, Autodesk Digital Prototyping streamlines the product development process from start to finish.

Learn more or purchase

Access specialists worldwide who can provide product expertise, a deep understanding of your industry, and value that extends beyond your software purchase. To take advantage of Autodesk Digital Prototyping, contact an Autodesk Authorized Reseller near you by visiting www.autodesk.com/reseller or learn more at simulation.autodesk.com.

Autodesk Education

Autodesk offers students and educators a variety of resources to help ensure students are prepared for successful design careers, including access to free* software, curricula, training materials, and other resources. Get expert guidance at an Autodesk Authorized Training Center (ATC®) site, and validate skills with Autodesk Certification. Learn more at www.autodesk.com/education.

Autodesk Subscription

Subscribe to Autodesk® Maintenance Subscription for Autodesk® Simulation software. Maintenance Subscription gives you an advantage with upgrades to the latest software releases, flexible licensing rights, powerful cloud services, and technical support.** Learn more at www.autodesk.com/maintenance-subscription.

Autodesk 360

The Autodesk® 360 cloud-based framework provides tools and services to extend design beyond the desktop.† Streamline your workflows, effectively collaborate, and quickly access and share your work virtually anytime, from anywhere. Learn more at www.autodesk.com/autodesk360.

*Free Autodesk software licenses and/or cloud-based services are subject to acceptance of and compliance with the terms and conditions of the license agreement or terms of service, as applicable, that accompany such software or cloud-based services.

**All Subscription benefits are not available for all products in all languages and/or regions. Flexible licensing terms, including previous version rights and home use, are subject to certain conditions.

†Access to services requires an Internet connection and is subject to any geographical restrictions set forth in the Terms of Services.

Autodesk, the Autodesk logo, AutoCAD, ATC, Autodesk Inventor, and Inventor are registered trademarks or trademarks of Autodesk, Inc., and/or its subsidiaries and/or affiliates in the USA and/or other countries. Nastran is a registered trademark of the National Aeronautics and Space Administration. SolidWorks is a registered trademark of Dassault Systèmes SolidWorks Corporation. All other brand names, product names, or trademarks belong to their respective holders. Autodesk reserves the right to alter product offerings and specifications at any time without notice, and is not responsible for typographical or graphical errors that may appear in this document. © 2015 Autodesk, Inc. All rights reserved.