

Composing for the Marimba:
Tools and Techniques for Composers

by

Joseph Millea

A Research Paper Presented in Partial Fulfillment
of the Requirements for the Degree
Doctor of Musical Arts

Approved April 2015 by the
Graduate Supervisory Committee:

Jeffrey Smith, Chair
Rodney Rogers
Deanna Swoboda

ARIZONA STATE UNIVERSITY

May 2015

ABSTRACT

This document offers composers a contextual reference and pragmatic overview of the modern marimba. This guide is not designed as an orchestration text, suggesting ways to write for the instrument, rather, it illustrates through examination of well-known solo and chamber works how selected composers have effectively written for the instrument.

A guide for basic notation and examples of successful notation are included, as well as the basics of performer techniques. Samples of problematic, sometimes impossible passages are included to show the instruments and its performers' current limitations. The construction of the marimba and how it is tuned, a guide to mallets, and all of the current established extended techniques is also included. The majority of the information comes from the citation of established research on the marimba, composers and performers, and the author's own experiences.

The intention of this document is two fold: to give composers who are unfamiliar with marimba a resource to begin composing for the instrument effectively, and for those composers who are familiar with the marimba it is designed to spark their creativity in an efficient and effective manner. The ultimate goal of this document is to create compositional momentum for marimba solo and chamber works and grow the repertoire, which is still in its infancy.

For Marilyn Clark Silva

You are the love of my life and the unconditional support you have given me throughout this process is tremendous. In addition to the wonderful contributions you have made to this project, you continue to make me a better person every day.

ACKNOWLEDGMENTS

I would like to thank my fellow Arizona State University percussionists. The welcoming environment is unparalleled and the never-ending willingness helped make this project all the more rewarding. I would like to acknowledge my first percussion teachers Brian Duffy and Matt Kettlehut. Without your nurturing spirit and inspiring love of music, I would not be where I am today. You are models of what it means to love what you do. To Fernando Meza, thank you for your support in the beginnings of my collegiate career. You taught me how to be a musician rather than just a drummer. Thank you to Daniella Ganeva and David Hockings at the Royal College of Music in London. Your incredible musicianship and tutelage continues to inspire me everyday.

To the late Dr. Mark Sunkett for teaching me how to truly listen. I would not be where I am today without your teachings and not a day goes by when I don't use the lessons you taught me. You are deeply missed. A special thanks goes to Dr. J.B Smith for his seemingly endless supply of promptness, detail, musicianship, patience, and encouragement. Your care and support of me these past six years has made my time at ASU the most rewarding time of my life and it is due to your wonderful leadership. Thank you to my committee member Dr. Rodney Rogers and Dr. Deanna Swoboda for the time, tremendous effort and time they have put into this document.

Last but not least, I wish to acknowledge the love and support of my family. I am lucky to come from such wonderful supportive parents and have such amazing siblings.

TABLE OF CONTENTS

	Page
LIST OF FIGURES.....	viii
LIST OF MUSICAL EXAMPLES.....	x
PREFACE.....	xii
CHAPTER	
1 MARIMBA HISTORY	1
1.1 Development of the Chromatic Marimba.....	1
1.2 The Modern Marimba.....	3
1.3 Development of Marimba Literature.....	4
2 CONSTRUCTION AND TUNING	7
2.1 Frame Components.....	7
2.2 Resonators.....	9
2.3 Bars and Tuning.....	12
3 MALLETS	15
3.1 Mallet Components.....	16
3.1.1 Shaft.....	16
3.1.2 Wrapping.....	17
3.1.3 Core	17
3.1.4 Weight	18
3.1.5 Non Standard.....	19
4 NOTATION	21
4.1 Basic Notation.....	22

CHAPTER	Page
4.2 Sticking	25
4.3 Roll Notation.....	27
4.4 Articulation	30
4.5 Embelishments.....	32
4.5.1 Grace Notes	32
4.5.2 Glissandi	33
4.6 Dynamics	34
5 PERFORMER LIMITATIONS	36
5.1 Extreme Registers and Intervals.....	36
5.2 Extreme Dexterity.....	39
5.3 Manuals.....	40
5.4 Extreme Octave Shifts	42
5.5 Kinesthetic and Tactile Considerations.....	43
5.6 Other Limitations.....	43
6 MARIMBA TECHNIQUES	44
6.1 Number of Mallets.....	44
6.2 Stroke Types	46
6.2.1 Independent	46
6.2.2 Double Vertical	47
6.2.3 Alternating.....	49
6.2.4 Lateral.....	49
6.2.5 Triple Lateral	51

CHAPTER	Page
6.3 Mallet Angle	53
6.4 Roll Types	54
6.4.1 Hand-to-Hand	54
6.4.2 Independent	54
6.4.3 Ripple.....	56
6.4.4 Lateral	57
7 EXTENDED TECHNIQUES AND THEIR NOTATIONS	59
7.1 Dead Strokes	59
7.2 Dampening/Muting and Prepared Marimba.....	60
7.3 Mallet Shafts	63
7.4 Nodes	65
7.5 Harmonics	66
7.6 Bowing.....	66
7.7 Fingers/Fingernails	67
7.8 Frame and Resonators.....	68
7.9 Mandolin/Split Bar Rolls.....	70
7.10 Glissandi	71
7.11 Six Mallets	73
7.12 Alternative Implements	73
8 CONCLUSION	78
REFERENCES	80

APPENDIX	Page
A MARIMBA DIAGRAM	83
B ACCOMPANYING WEBSITE.....	85
C MAJOR MANUFACTURER CHARACTERISTICS.....	87
D COPYRIGHT PERMISSIONS.....	89
BIOGRAPHICAL SKETCH	107

LIST OF FIGURES

Figure	Page
2.1. Both Types of Standard Marimba Frame Ends	8
2.2. Side and Upper View of Tubular Resonators	10
2.3. Side and Upper View of Box Resonators	11
2.4. Side and Upper View of Oval Resonators	12
2.5. Marimba Bar Cross Section	13
3.1. Parts of the Mallet	16
3.2. Standard Notational Symbol of Soft, Medium, and Hard Mallets	18
3.3a. Round and Oval Shaped Mallet Heads	19
3.3b. Round and Oval Mallets Played at an Angle (with the tip)	19
4.1. Common Marimba Ranges	22
4.2. Proper Roll Notation	28
4.3. Two Common Ways of Starting Rolls	28
4.4. Notating Different Starts to the Roll	29
4.5. Use of Appoggiatura Grace Note	33
4.6. Dynamic Independence	35
5.1. B Major Triad, Notated and Pictured	41
5.2. Hand Positions of Bb Major and B Major Chords	43
6.1. Possible Lateral Stroke Permutations	50
6.2. Possible Triple Lateral Stroke Permutations	52
6.3. One-handed Roll on a Single Note	55
7.1a. Mallet Shaft Played Directly on the Bars	63

Figure	Page
7.1b. “Splash/Cluster” Photo	64
7.2. One-handed Roll with Shaft of the Mallet.....	65
7.3. Symbols for Bowing and Mallets	67
7.4. Notated Pitch-Bend Glissando with a Mandolin Roll.....	72
7.5. Hybrid Marimba/Crotale Mallet	76
7.6. Hybrid Mallet/Brush	77

LIST OF MUSICAL EXAMPLES

Example	Page
4.1a. <i>Merlin II</i> by Andrew Thomas, mm. 1-4.....	23
4.1b. <i>Khan Variations</i> by Alejandro Vinao, mm. 165-167.....	24
4.2. <i>Dances of Earth and Fire</i> by Peter Klatzow, mvt. I mm. 38-42	24
4.3. Baroque Suite by Daniel Levitan, mm. 7-9	26
4.4. Prelude No. 1 by Raymond Helble, mallet symbol from score, mm. 1-2	26
4.5. <i>Finale from Dido and Aeneas</i> by Henry Purcell, mm 5-7	31
4.6. <i>Mirage pour Marimba</i> by Yasuo Sueyoshi, Section a - 4	33
4.7. <i>Variations after Viñao</i> by Gene Koshinski, mm. 158-159	34
5.1a. <i>Merlin II</i> , by Andrew Thomas, mm. 205-207.....	37
5.1b. <i>Merlin II</i> , mm. 205-207, (Zeltsman Transposition).....	37
5.2. <i>Mirage pour Marimba</i> by Yasuo Sueyoshi, mm. 128-130.....	40
5.3. <i>Dances of Earth and Fire</i> by Peter Klatzow, mm. 68-73	42
6.1. <i>Variations after Viñao</i> by Gene Koshinski, mm. 198-200	45
6.2. <i>Uneven Souls</i> by Nebojsa Zivkovic, marimba, mm. 58-61	47
6.3a. Marimba Concerto by Richard Rodney Bennett, mm. 21-23	48
6.3b. Marimba Concerto by Richard Rodney Bennett, m. 164 (cadenza).....	48
6.4. <i>Two Mexican Dances</i> by Gordon Stout, mvt. 1, mm. 1-3	49
6.5. <i>Libertango</i> , by Eric Sammut, mm. 73-75	50
6.6. <i>Apo to Kolpo Kassandra</i> by David Kosviner, mm. 220	51
6.7. <i>Apo to Kolpo Kassandra</i> by David Kosviner, mm. 83	51
6.8. <i>Ezekiel's Wheel</i> by Kevin Bobo, mm. 159 to 161	52

Example	Page
6.9. <i>Long Distance</i> by Steven Snowden, Brooklyn mvt. 2, mm. 10-14	53
6.10. <i>Il Canto dei Gondolieri</i> by Nebojsa Zivkovic, mm. 47 to 49.....	54
6.11. <i>After Syrinx II</i> by Richard Rodney Bennett, m. 1	56
6.12. <i>Like Blind Men Tapping in the Dark</i> by Libby Larsen, mm. 54-56.....	57
6.13. <i>Apo to Kolpo Kassandra</i> by David Kosviner, mm. 134-135.....	57
7.1. <i>Dances of Earth and Fire</i> by Peter Klatzow, mvt. I, mm. 53-54	60
7.2. Marimba Quartet by Daniel Levitan, mvt. I, player 1, mm. 9-10.....	61
7.3. <i>Libertango</i> by Eric Sammut, mm. 44-45	62
7.4. <i>Long Distance</i> by Steven Snowden, <i>Brooklyn</i> mvt., mm. 10-14.....	66
7.5. <i>Stubernic</i> by Mark Ford, frame diagram.....	68
7.6a. <i>LIGNEOUS I</i> by Andy Akiho, marimba part, mm. 27	69
7.6b. <i>LIGNEOUS I</i> by Andy Akiho, marimba part, mm. 29	70
7.7. <i>Il Canto Dei Gondolieri</i> , by Nebojsa Zivkovic, mm. 3-4.....	71
7.8. <i>Evening's Sabres</i> by Philip Carlsen, Player 2, mm. 230-232.....	72
7.10. <i>Galilee Impressions</i> by Keiko Abe, mm. 16-18	73

PREFACE

Presently the marimba is one of the most popular percussion instruments. In the last 30 years the instrument has gone from being on the fringes of the orchestra percussion section to inclusion in every university percussion department and professional group. The instrument itself has undergone many changes in the last 100 years, starting with wooden “gut” resonators, frames and bars made from local wood and no wheels. Today marimbas are commonly found with height adjustability, metal frames, brass tunable resonators, and bars made from the finest rosewood in the world, tuned with computerized tuning systems. However, the repertoire of the marimba, when compared to other standard orchestral instruments (Violin, Cello, Piano, etc.), it is still in its infancy. While wonderful composers such as Andrew Thomas, Richard Rodney Bennett, Gunther Schuller, Paul Lansky, and Jacob Druckman have written for the marimba, the bulk of the repertoire still comes from marimba players themselves, and historical repertoire such as the Bach cello and lute suites or Chopin piano transcriptions. However, this should not be considered a negative development. From a purely technical standpoint the marimba has grown exponentially. Forty years ago, performing a four-mallet marimba solo on a culminating doctoral recital would’ve been considered appropriate. Today it is a requirement on most undergraduate entrance auditions.

Presently, the natural evolution of the marimba is to go from filling its repertoire with the contributions of percussionists to composers being the primary contributors. Speaking from personal experience, a conductor once said to me, “I feel like I should be drinking out of a coconut!” This was during a rehearsal for an orchestral work with solo

marimba. The association of the marimba and music one would listen too while on vacation was made clear. Thus the need for serious compositions has never been greater.

In addition to the current lack of repertoire for the marimba, the inspirations for this project stems mainly from seeing great composers write mediocre pieces for marimba. This is no fault of the composers, but a lack of understanding and available resources illustrating what the instrument can do. It is capable of so much more than fast scales with two mallets. Harmony and melody are easily produced simultaneously and polyphonic or homophonic textures work very well. The marimba is capable of playing softer than a single violinist and louder than the loudest brass sections. It can produce colors ranging from dark and earthy to bright and clear, from introspective and subdued to brash and showy. The marimba has proven to be appropriate in most situations including large ensembles, chamber music, solo, with accompaniment, and more recently electronics.

It is my hope that composers use this document (and its accompanying website) to find inspirations to grow the repertoire. Historically composers are the ones to push the development of a given instrument. Hector Berlioz specified the mallets he wanted in his *Symphonie Fantastique* (1830). Debussy and Elgar included antique cymbals (crotales) in their works. John Cage and the west coast composers helped make instruments such as the brake drum a standard inclusion in all percussion closets. Through the examination of the current repertoire, this document shows how composers have effectively written for the instrument. This document also gives an overview of the history of the modern marimba, the components of the frame, the tuning of the bars, current performer

techniques, current limitations, available mallets, and notational guides. The final chapter is an examination of the current extended techniques for marimba.

The appendices contain a diagram of a Yamaha model number 5100 marimba, a link to the accompanying website, and a chart detailing the characteristics of each major marimba manufacturer.

CHAPTER 1

MARIMBA HISTORY

1.1 Development of the Chromatic Marimba

The marimba, in one form or another, has been around for hundreds of years. As musician James L. Moore put it, marimba is “one of the oldest instruments known to man.”¹ According to percussionist James Blades, there is pictorial evidence in the temple of Panataran in Java from the fourteenth century and literary references of tuned metallophones as early as 900 A.D. Blades concludes that these were an “extension of the already highly developed trough xylophone.”² The modern chromatic marimba used today has only been around for approximately one hundred years. Guatemalan marimba player Sebastian Hurtado was the first person to apply the chromatic keyboard to the marimba in 1894.³ Up until then he had performed only Guatemalan folk music, which only required the use of diatonic pitches. In order to perform European classical music on the marimba he needed to add the other five pitches of the chromatic scale and increase the range to 5.5 octaves. He also used wooden boxes to replace the gourd resonators that were traditionally used. With the help of marimbists and composers Mariano Valverde and Rosendo Barrios, the chromatic marimba was developed and the resonator dimensions were standardized.⁴ Around 1908, the marimba was introduced to the United States and Europe via the Hurtado Brothers Marimba Band’s international tours.⁵

¹ Conklin, M. Christine, "An Annotated Catalogue of Published Marimba Concertos in the United States from 1940 – 2000," DMA *Thesis*, Norman: University of Oklahoma, 2004, 1.

² Blades, James, *Percussion Instruments and their History*, London: Faber and Faber Limited, 1984, 84.

³ David P. Eyler, “The Hurtado Brothers’ Royal Marimba Band of Guatemala,” *Percussive Notes*, vol. 31 no. 3 (February 1993): 48.

⁴ Frank K. MacCallum, *The Book of the Marimba*. (New York: Carlton Press, 1969),16.

⁵ Vida Chenoweth, *The Marimbas of Guatemala*. (Louisville, Kentucky: University of Kentucky Press, 1974),76.

In 1910 the J.C. Deagan and Leedy companies began manufacturing marimbas in the United States.⁶ Musician and conductor Clair Omar Musser (1901-1998) joined the J.C. Deagan Company in the 1930's, designing several marimba models. The *Century of Progress* marimba was built as part of a 100-piece Marimba Orchestra to take place at the "Century of Progress Exposition" in Chicago in 1933.⁷ According to the *Deagan Resource*, an online archive of J.C. Deagan Company information, the *Century of Progress* came in 3.0, and 3.5 octave standard models as well as a 1.0 and a 1.5 octave bass marimba.⁸ The next model produced by Mr. Musser was the *King George*, which was built in 1934. One hundred and one of these instruments were constructed and were intended to tour Europe with a concluding performance at the coronation of King George VI. Unfortunately, due to negotiation problems, they were not allowed to perform in England or Germany. However, the orchestra did perform in France and Belgium and later gave a performance in New York City's Carnegie Hall.⁹ According to the *Deagan Resource*, The King George marimbas came in two 4.0 octave models (C-C and F-F), a 3.5 octave model, and a 2.0 octave bass marimba.¹⁰ In 1934, Musser left Deagan and started his own company (which is still in existence today). Musser Inc. built many more models of marimba, establishing the design, which is still evident in today's modern marimba.¹¹

⁶ Frank K. MacCallum, 31.

⁷ Linda Pimentel, "The Aristocracy of Manufactured Marimbas," *Percussive Notes*, vol. 21 no. 1 (October 1982): 61-62.

⁸ The Deagan Resource, *Marimbas*, <http://www.deaganresource.com/marimbas.html> (accessed February 23, 2015).

⁹ Linda Pimentel, 62.

¹⁰ The Deagan Resource, *Marimbas*, <http://www.deaganresource.com/marimbas>.

¹¹ Linda Pimentel, 63.

1.2 The Modern Marimba

There have been many changes to the design and construction of the marimba over the ensuing years. Shigeo Suzuki, a chief engineer for marimba research at Yamaha, secured the services of marimba virtuoso Keiko Abe in 1963 in order to improve the instruments projection and clarity. Following the premier of Minoru Miki's *Concerto for Marimba and Orchestra* in 1969, it was decided that the Musser marimba Abe had been using since 1957 could not adequately project through an orchestra.¹² Abe encouraged Yamaha to build a new marimba from scratch, one not based on older designs. She made specific requests for clear intonation, a wide dynamic range, a bright sound in the high register, and rich sound in the low register. In 1971 Yamaha came out with a four-octave model, which Abe began using in her concerts. Soon after this, tunable resonators were introduced to allow for optimal resonance in a variety of concert spaces. In 1973, a four and a half octave marimba was introduced. This was the instrument Abe used until 1980 when she requested a bass extension be added, lengthening it to five octaves. In 1984 Yamaha made a stand alone five-octave instrument, the YM 6000, which is still in use today by Abe as well as many other marimba players.¹³

Other manufacturers have since offered their version of the five-octave marimba. This has come with many different designs and construction techniques. Today major manufacturers include: Marimba One, Mallettech, Demorrow, and Musser in North America; Majestic, Adams, Bergerault, Kolberg, Premier, and Vancore in Europe; and Kori, Jiayuam, and Yamaha in Asia. Mallettech, Musser, Bergerault and Demorrow now

¹² Kite, Rebecca, *Keiko Abe -- A Virtuoso Life: Her Musical Career and the Evolution of the Concert Marimba*, Leesburg, Virginia: Gp Percussion, 2007, p. 207.

¹³ Kite, Rebecca, "Keiko Abe's Quest: Developing the Five-Octave Marimba," *Percussive Notes* 36, no. 2 (April 1998): 52-54.

offer tunable resonators across the range of the instrument, allowing the player to adjust to different performance spaces, temperature, and barometric pressure, Majestic and Yamaha offer tunable resonators in the lowest register. Adams, Yamaha, Bergerault, Vancore, and Kori offer a box shaped resonator. For the characteristics of each manufacturer see appendix C.

Rosewood had long been favored for the bars but due to increasing costs as a result of dwindling supplies, alternatives, including synthetic materials and woods such as paduk and babinga, have become increasingly popular. These materials, though cost-effective, do not have the same resonant qualities as rosewood. Specifications like bar size and resonator shape are not standardized and can vary from manufacturer to manufacturer. Today an instrument of at least 4.3 octaves is still available, but the five-octave marimba is now standard among professionals and universities and is becoming more common for high schools.

1.3 Development of Marimba Literature

Some would argue that solo marimba literature is still in its early stages of development. In 1963 James Moore stated, “Until very recently, the marimba repertory consisted mainly of transcriptions of classical works, folk songs, and popular song arrangements.”¹⁴ Marimba concerti played a large role in the development of marimba literature. In her annotated catalogue of published marimba concerti (while discussing Paul Creston’s *Marimba Concertino* (1940)), Christine Conklin states, “The marimba concerto, therefore, played a very important role in the development of the solo marimba

¹⁴ Conklin, M. Christine, "An Annotated Catalogue of Published Marimba Concertos in the United States from 1940 – 2000," *DMA Thesis*, Norman: University of Oklahoma, 2004, 1.

repertoire, especially in its earliest stages.”¹⁵ Clair Omar Musser contributed various preludes and etudes in the 1940’s as well.

Darius Milhaud’s *Concerto for Marimba, Vibraphone, and Orchestra* was written in 1947. In 1956 Robert Kurka wrote his *Concerto for Orchestra* for marimba soloist and leading figure in marimba development, Vida Chenoweth. Shortly thereafter the marimba was introduced to Japan.¹⁶ As the development of the instrument progressed, Keiko Abe commissioned more works for the marimba. In her dissertation *The 1986 National Endowment for the Arts Commission: An Introspective Analysis of two Marimba Works...*, I-Jen Fang states “Fifty-four pieces were written for her by thirty-two composers between the years of 1964 and 1986.”¹⁷

Since then, many composers have written for the marimba including Andrew Thomas, John Serry, Peter Klatzow, Richard Rodney Bennett, Alejandro Vaino, Jacob Druckman, Paul Lansky and Gunther Schuller. Percussionist James Holland states in his book *Practical Percussion*, “So much was written for the marimba in the last quarter century; the Steve Weiss catalogue alone has over 600 unaccompanied marimba works...”¹⁸ Today a large part of the marimba repertoire still comes from marimba players themselves, creating an interest in the marimba. Due to the technical innovations and accessibility of this music, it is arguably the fastest growing field in solo percussion. Though the argument that performers can write better for their own instrument (i.e.

¹⁵ Conklin, 2.

¹⁶ Fang, I-Jen, "The 1986 National Endowment for the Arts Commission: An Introspective Analysis of two Marimba Works, Reflections on the Nature of Water by Jacob Druckman and Velocities by Joseph Schwantner, Together with three Recitals of Selected Works by Kekio Abe, Christopher Deane, Peter Klatzow, Wayne Siegel, Gitta Steiner, and Others," (*DMA Diss*, University of North Texas, August 2005), 3-10.

¹⁷ *Ibid*, 7-9.

¹⁸ Holland, James, *Practical Percussion*, Lanham, Maryland: Scarecrow Press, 2005, 67.

Rachmaninoff, Chopin, Liszt, Bartok, Paganini, etc.), percussion performers, and there are many percussionist who also compose wonderfully, today the majority are trained as interpreters, thus the need for composers writing for marimba arises. In any case, the listener ultimately judges the music, not the composer.

CHAPTER 2

CONSTRUCTION AND TUNING

As with any musical instrument, modern marimbas can be built in many different ways, and there are differing opinions on how the instrument should sound. Despite this, all marimbas have a common design consisting of the frame ends, cross beam, rails, resonators, and bars. For a diagram of a common marimba (Yamaha 5100), see Appendix A: Marimba Diagram.

2.1 Frame Components

The high and low frame ends of the instrument serve to support all parts (resonators, rails, and bars) and allow for wheels or castors to be attached. The size can vary, but in general they run the length of the two lowest bars on the low end (about 3.5 feet) and the two highest bars on the high end (about 1.5 feet).

There are two types of frame ends to consider. The more common design is that of metal or wooden beams connected to the wheels and the wooden end on top, which supports the rails and bars. The other design to consider is the flat panel, usually found on the Musser 250 Concert Grand. See figure 2.1 below. While this does not affect the sound of the bars, the distinction plays a role in frame and resonator sounds (see extended techniques) and how they can be achieved.



Figure 2.1: Both types of standard marimba frame ends. Left to right, Adams Artist 5.0 octave high end, Musser 4.3 Octave low end.

The crossbeam runs the length of the instrument and serves to support the instrument structurally by connecting the frame ends. It is typically made of metal or wood. When made of metal it is tubular or square shaped, and when made of wood it is plank shaped. If the sound of the cross beam is desired, it should be noted that access to it is limited to the upper two thirds of the instrument due to the low-end natural resonators obstruction.

The rails run the length of the keyboard and are attached to each frame end. The function is to suspend the bars via the string that runs through the nodal points of each bar. There are four rails per marimba (two per manual) and hooked spacers in between on which the bars are suspended. These metal spacers are typically wrapped in rubber or felt to prevent unwanted noise and sit in line with the nodal points of each bar. The rails are numbered 1-4, with 1 being on the performer's side and 4 being on the audience side of the instrument. If frame sounds are desired, rail one is the most accessible while rail four

would require the performer to be on the opposite side of the instrument. Rails two and three are essentially inaccessible unless the instrument is disassembled or the performer lies underneath the center of instrument.

2.2 Resonators

Resonators are a crucial part of the marimba sound production. They are suspended from each end directly below the bars and are typically made of brass or aluminum. The tubes create an acoustic cavity resonator each of which is tuned to the fundamental pitch of the bar directly above them. A common misconception is that the resonators are open at both ends; however, they are closed at the bottom and open at the top.¹⁹ If sound amplification is desired, the microphone(s) must be placed either above the instrument or underneath as close to the tops of the resonators as possible.

Resonator shapes vary on the low end of the marimba (approximately the lowest 7th) by manufacturer with the high end being tubular on virtually all models. Physicist Heather Hill in her thesis on the Acoustics of Marimba Bars states, “The resonators below the notes between C2 and C3 tend to vary in design the most between manufacturers due to the lower frequency values associated with the bars in the lower octave of the instrument.”²⁰ Hill goes on to state that resonator’s purpose is to amplify only the fundamental of the bar, allowing the notated pitch of the bar being played to be the majority of what the audience hears.²¹

On Malletch, Demorrow, Majestic, and Yamaha (6000) models, the low-end resonators are tubular throughout with joints welded together giving them a curve (on the

¹⁹ Hill, Heather L., "Acoustics of Marimba Bars," (master's thesis, Itaca College, May 2013), 1-2.

²⁰ Ibid.

²¹ Ibid, 28.

Malletech MJB model the resonators are bent rather than sectioned in joints). The thought behind this type of design is to give a more accurate fundamental note with reduced harmonics. See figure 2.2 below.



Figure 2.2: Side and upper view of tubular resonators (Pictured, Demorrow M5 Concert Marimba).

On Yamaha 5100 (and lower), Adams, and Bergerault models the low-end resonators are a box shape. The rationale behind this design is to produce a strong fundamental note with isolated harmonics, see figure 2.3.



Figure 2.3: Side and upper view of box resonators (Pictured, Adams MAHC50 Artist Marimba).

The third low-end resonator type is produced by Marimba One and is commonly referred to as the oval shape design. What this amounts to is a combination of both tubular and box-shaped resonators resulting in an inverted tubular resonator. The sound, while not significantly different from other manufacturers, is generally regarded as being very warm and smooth. See figure 2.4. Currently there is a wide variety of bar widths and resonator shapes and designs available. For details on the characteristics of each manufacturer, consult appendix C.



Figure 2.4: Side and Upper view of oval resonators (Pictured, Marimba One 3000 series).

2.3 Bars and Tuning

The bars are the principle sound-producing parts of the instrument. In his study of the science of the marimba, Greg Merrill states, “The bars of a marimba work on the fundamental principal of a vibrating bar with two free ends: when some action, such as the impact of a mallet, sets such a bar into movement, it bends transversely...”²²

As with any wooden musical instrument, lower-quality wood will produce a lower quality-sound. Common materials used for marimba bars are Honduran rosewood, paduk, babinga or a synthetic material, each chosen for their density and resonance. The bars are in the shape of a rectangle with the underside of each bar shaped into an arc. This is to allow the tuning of the higher harmonics of each bar.²³ The bars can be struck at three different points, each offering a different timbre; the center (directly above the

²² Merrill, Greg, *The Marimba: Scientific Aspects of its construction and performance*, 1996, http://faculty.smu.edu/ttunks/projects/merrill/Mar_2.html (accessed March 7, 2015), p. 2.

²³ Hill, Heather L., "Acoustics of Marimba Bars," (Senior Thesis, Itaca College, May 2013), 1.

resonators), between the center and node (or by symmetry, the edge), and directly on the nodal point. See figure 2.5.

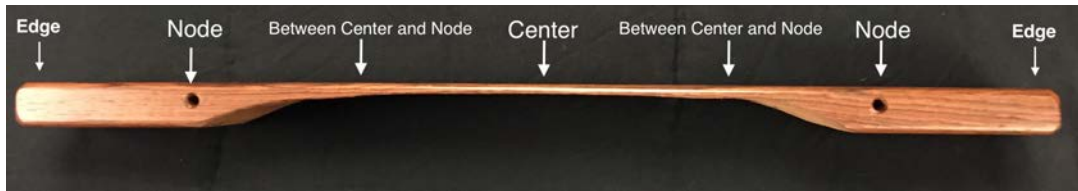

Figure 2.5: Marimba Bar Cross Section.

The center will accentuate the fundamental and minimize harmonic content. When struck off-center (or the edge), the harmonics will be more prevalent. A common misconception of percussionists and composers alike is that the edge of the bars will produce the same quality sound as the center. However the edge will sound similar to the area between the center and the node producing a prevalence of the second partial.²⁴ Playing on the edge of the bar is usually limited to the accidentals and only when needed, such as a very fast passage or an awkward position of the hands. When struck on the node the sound will not contain very much of the fundamental pitch of the bar. Composing with specific spots of the bar in mind should be thought of in the same way that string players play with different bow placement on the string. Different colors can be produced but specifying these will lead to less creative freedom of the performer. These subtleties will be difficult to hear in a large ensemble or chamber setting and should be limited to solo and small chamber works.²⁵

Each bar is generally tuned to the harmonic of two octaves and three and a half octaves above the fundamental pitch. For example, if C is the fundamental we also hear

²⁴ Paterson, Robert A., *Sounds that Resonate: Selected Developments in Western Bar Percussion During the Twentieth Century*, DMA Diss., Ithaca: Cornell University, 2004, p. 101

²⁵ Ibid, 101-102.

the harmonics of C two octaves above and E three and a half octaves above the fundamental.²⁶ This is one of the principal intonation differences between marimba and a xylophone. In addition to more wood mass per bar and the part of the tree from which the wood is taken, the contemporary xylophone is tuned to the twelfth overtone. For example, when C is struck on a marimba we would hear E as the prominent overtone. On a xylophone, we would hear G as the prominent overtone.²⁷ Because of this a composer should be aware of possible harmonic interference in the lower register of the marimba. If a certain interval (minor 10th, minor 17th, minor 24th, etc.) is struck, dissonance of the interval and its resultant harmonic will be very audible.²⁸

Careful consideration needs to be made when composing in the lower register of the marimba. Although every modern marimba contains bars that go from large to small, the rate of change in bar width can vary greatly from manufacturer to manufacturer. On larger models as produced by Demorrow or Mallettech, the demands placed on the performer are amplified due to the greater distance between the bars. It is best to consult with a professional percussionist or marimba player to determine if there will be issues on particular brands and models.

²⁶ Hill, 4-5.

²⁷ Kite, Rebecca, *Keiko Abe -- A Virtuoso Life: Her Musical Career and the Evolution of the Concert Marimba*, Leesburg, Virginia: Gp Percussion, 2007, p. 135-136.

²⁸ Solomon, Samuel Z, *How to Write for Percussion*, New York: SZSolomon, 2002, p. 84.

CHAPTER 3

MALLETS

Mallets play an incredibly important role in the sound of a marimba. Because mallet manufacturing is a lucrative business, hundreds of different mallet types are available. They can produce timbres ranging from hard to soft, bright to dark, heavy to light and everything in between. The mallet that a performer selects for a given piece, according to musician Greg Merrill, is as important as the other factors that affect the sound of the marimba: the construction of the bars, the tuning of the bars, the use of resonators, and playing areas.²⁹ While the construction and tuning of the bars and use of resonators is generally out of the hands of composers and performers, the mallet selection and playing areas are aspects of control that can be utilized fully by the composer and/or performer.

In general, most performers will have their own personal preference with regard to mallet choice. As stated by composer Betsy Jolas in the performance notes preceding her work for solo marimba *Morning Thoughts* (2009), “I assumed it be better to let the performer himself (herself) select them [mallets] as suggested by the character (dynamics, register, etc.) of the music that implies a great variety of colors.” In addition to the stylistic indication or desired sound (e.g. *Dark and Heavy*), guidance of the mallet choice from the composer is always welcome. However, most competent marimba players will have a preference; therefore, mallet suggestions are not always necessary.

Each mallet is constructed of three parts: the core, shaft, and wrapping. Various combinations of these dictate the size, weight, shape and type. See figure 3.1.

²⁹ Merrill, Greg, *The Marimba: Scientific Aspects of its construction and performance*, 1996, http://faculty.smu.edu/ttunks/projects/merrill/Mar_2.html (accessed March 7, 2015), p. 16.

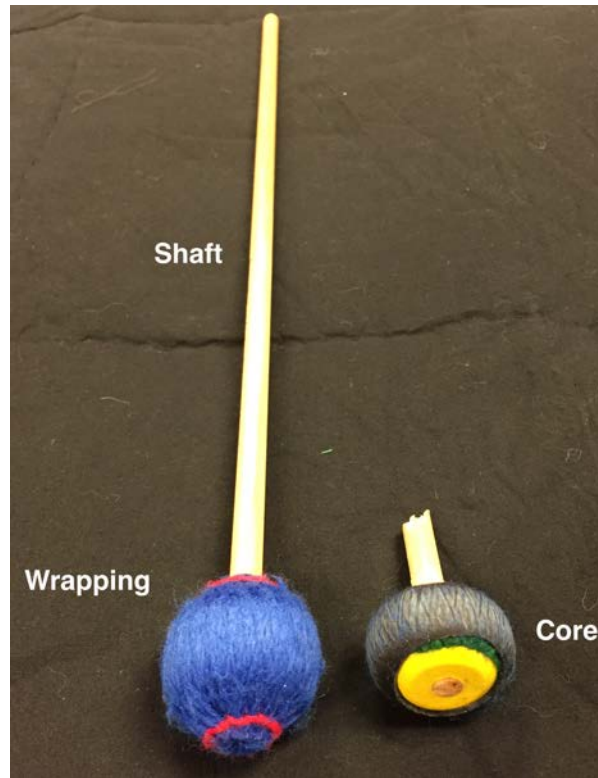

Figure 3.1: Parts of the mallet, Innovative Percussion Inc. NJZ4 shown.

3.1 Mallet Components

Mallet shafts are made from two basic materials, birch and rattan, with occasional variations (cedar and ramen). Birch-shafted mallets are less flexible but very strong; cedar offers slightly more flexibility but is slightly weaker, and rattan is very flexible offering high durability, but the increased pliability can make rattan mallets difficult to control for some. Rattan mallets, because of their durability, are preferred when using the shaft to strike the bars directly. When using certain extended techniques involving the mallet shaft, it is best to use caution to prevent damage to the mallet shafts or to the instrument itself. This includes mallets clicked together, mallets played on the bars, and mallets striking other percussion instruments. See chapter 7, extended techniques.

The length of the shaft does vary, however it is typically not a concern unless a passage containing large intervals in a single hand merits a non-standard shaft length. Though not standard practice, a composer can suggest a mallet shaft of non-standard length. In Leigh Howard Stevens' arrangement of *The Adventures of Ivan* by Aram Khachaturian, he suggests using a longer mallet to reach a low bass note during a four-note roll. Though this does make the performance slightly more manageable, it is not necessary for a successful performance. Caution must be used when suggesting a mallet with a longer shaft as this may require the performer to purchase a custom mallet which can be expensive, or make their own by hand, which can be tedious and/or result in a low-quality mallet head.

Each mallet can be wrapped using yarn, wool, cord, or any mixture of these. As stated above, this is generally left up to the performer but the composer may specify mallets when considering timbral effect. Acrylic yarn is the most common material and will produce a warm soft sound. Wool has the same effect but is less durable. Cord will produce a slightly more articulate sound. Some manufacturers combine these materials to create a variety of sound and timbre potentials.

The core of the mallet is a main determining factor in how hard or soft a mallet sounds; overall size and weight also affect the sound. Common material includes solid rubber or plastic, swathed with varying thicknesses of felt (or rubber depending on the core material) before the wrapping is applied. This will define the mallet's degree of articulation. Soft, heavy mallets will generate a deep rich sound at the low end of the instrument but can have a "thuddy" dull sound on the upper end of the instrument. In contrast to the soft type of mallet head, a hard, light mallet will sound rich and articulate

on the high end of the marimba and thin and brittle on the low end. Considerations of the instrument range must be made when making mallet choices suggestions. It is possible to have four graduated mallets; graduated indicates that the mallets gradually go from softer in the left hand to harder in the right. This is a subtle effect but can make significant differences in both contrapuntal and homophonic voicings.³⁰ The standard way of indicating mallet type is shown below in Figure 3.2.

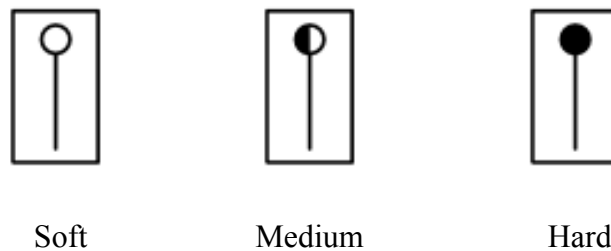

Figure 3.2: Standard notational symbol of soft, medium, and hard mallets.

The weight has a noticeable effect on the sound generated by a marimba bar. Lighter mallets will generally produce more fundamental pitch and fewer harmonics from the bar, but will have less resonance (especially in the lower register). Heavier mallets will produce slightly less fundamental pitch and slightly more harmonics with lots of resonance. However, heavy mallets lack definition in the upper register. Simply writing the desired mallet type at the top of the score or in the performance notes is common practice.

All of the previous factors affect the shape of the mallet. Generally mallets come in two shapes; round and oval (see figure 3.3a). The more wide the core is, the rounder it will be. With a narrow the core, the mallet will be more oval shaped. Round mallets will offer a more consistent timbre when played at different angles. Oval-shaped mallet will

³⁰ Wilson, Christopher. "Use and Selection of Graduated Mallets." *Percussive Notes*, Jan 2011: 38.

produce a clear tone when played normally and a much darker tone when played with the tip. This is illustrated in figure 3.3b. When playing with the tip of either a round or oval shaped mallet, the volume decreases greatly.



Figure 3.3a: Round (left) and Oval (right) shaped mallet heads.

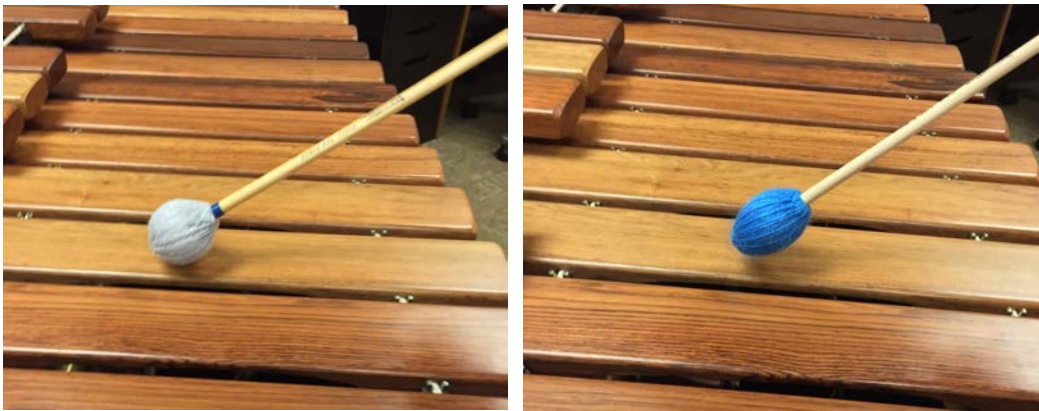

Figure 3.3b: Round and oval mallets played at an angle (with the tip).

There are some non-standard mallets worth noting. Two-toned mallets offer interesting timbral possibilities. They are made by wrapping a very hard core with extra yarn and/or a soft layer of foam between the wrapping and the core. This will produce a delicate timbre at soft dynamics and a very hard sound at loud dynamics. This type of mallet could be used to move quickly from choral-type passages to fast articulate passages and vice versa. Multi-toned mallets offer a similar sound envelope but to a

much lesser degree of extremity. The multi-tone mallet was first prescribed in a published composition in Minoru Miki's *Time for Marimba* (Ongaku No Tomo Sha).

Rubber mallets are another option. They offer a sound that is reminiscent of 19th century folk marimba playing. Generally, rubber mallets can offer an articulate attached sound no matter how hard the mallet actually is. This can be useful in chamber and large ensemble settings when projection and consistency of sound is needed. Many performers have come to use rubber mallets in specific compositions such as the marimba music of composer Steve Reich, *Nagoya Marimbas* (1994), *Drumming* (1970-1971), *Music for 18 Musicians* (1974-1976). (For alternative implements see chapter 7, extended techniques).

CHAPTER 4

NOTATION

Notation for the marimba can be from standard Western classical style to extreme graphic notation. Most marimba players are classically trained percussionists by trade and should be well adept at interpreting standard orchestral style scores as well as graphic scores such as the ones found in the music of Stockhausen, Cage, Haubenstock-Ramati, and others. If the music necessitates it (for instance extended techniques or a sonic effect or gesture), graphic notation may be appropriate. This allows more freedom for the performer and ensures, as British composer Reginald Smith Brindle states in regards to learning complex music, “No time is wasted.” If an effect or gesture is desired an improvised section may be warranted. As stated by percussionist Samuel Solomon in his book *How to Write for Percussion*, “Most percussionists are accustomed to improvising and can do so effectively. Instead of writing out a part completely, it may be better for the composer to write out an outline of the rhythm or indicate the character of the part and let the player fill in the rest.”³¹ In addition to graphic scores, the transcriptions of Bach and certain Debussy works very well on the marimba. Generally, the notation should be as clear as possible, minimizing the use of text within a score and maximizing performance notes preceding the score. It is best to consult with a professional in regards to notational clarity. As broad tenet, composers should notate what is most practical and what makes the most sense for the music at any given time. An unclear score will undoubtedly turn players away from a performance. Whether the score is handwritten or notated using a

³¹ Solomon, Samuel Z, *How to Write for Percussion*, New York: SZSolomon, 2002, p. 34.

computer notational program, the ability to communicate a composer’s intention in a reasonable amount of time is vital.

4.1 Basic Notation

The range of the marimba is generally five octaves but it does come in several other ranges as detailed in figure 4.1. A 5.0 octave goes from low cello C (C2) to C7, a 4.6 octave is useful for guitar transcriptions, a 4.3 octave is most common, and a 4-octave marimba is becoming obsolete.³² In general most universities and professionals will have access to a 5 octave marimba, but due to the varied nature of instrument availability it is best to offer parenthetical (optional) notes or an ossia measure when the range is below A2.

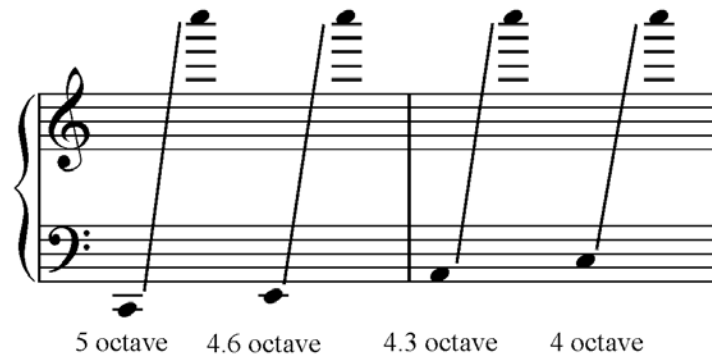

Figure 4.1: Common Marimba Ranges.

The staff type is crucial to the intelligibility of a given passage or composition. Performer preferences will vary but as stated by marimbist Nancy Zeltsman, “It is also preferable to see the entire marimba part written on two systems as with piano music.”³³ Zeltsman goes on to say that, due to the size of the marimba, it is helpful to see a large leap of several octaves on the page rather than a clef change or octave displacement

³² Solomon, p. 75

³³ Zeltsman, Nancy, *Memo to Composers*, 2015. <http://www.nancyzeltsman.com/memo-to-composers.html> (accessed January 28, 2015).

indication. This is especially welcome if the player will read the score during a performance. Should a player choose to memorize a work (which is quite common among marimba players), exceptions can be made.

Treble and bass clefs are the only common clefs in marimba notation. Alto, tenor, mezzo-soprano or any other type of moveable clef should not be used. Ledger lines are preferable with brevity. When a passage is written mostly with ledger lines, the appropriate “8va” or “8vb” symbol should be used. Beaming the notes across a grand staff is the most preferred method of notation. Two excellent examples of beamed grand staff utilization can be found in Andrew Thomas’ *Merlin* (1985) and Alejandro Viñao’s *Khan Variations* (2001), as shown below in 4.1a and 4.1b.



Music by Andrew Thomas

Copyright © 1985 by Associated Music Publishers, Inc. (BMI)

International Copyright Secured. All Rights Reserved.

Used by Permission

Warning: Unauthorized reproduction of this publication is prohibited by Federal Law and is subject to criminal prosecution.

Example 4.1a: *Merlin II* by Andrew Thomas, mm. 1-4, exemplary usage of the grand staff, not shown are the treble (upper staff) and bass (lower staff) clefs.



© Copyright 2001 by Alejandro Viñao.
Reprinted by permission.

Example 4.1b: *Khan Variations* by Alejandro Viñao, mm. 165-167. Exemplary usage of the grand staff.

A single staff is warranted when the work remains in a narrow range for a longer period of time (usually one or two lines on the page). The use of a mixed staff is useful when the music remains in a single clef for an extended period of time. An example of this can be found in Peter Klatzow's *Dances of Earth and Fire* (1987) as shown in example 4.2. Up until this point in the score it had been a single staff in bass clef. To a performer who is reading during the performance, there is no doubt of the clef change.



© Copyright 1987 by PM Europe.
Reprinted by permission.

Example 4.2: *Dances of Earth and Fire* by Peter Klatzow, mvt. I mm. 38-42. Example of a mixed staff.

As shown above, the score moves to a grand staff midway through a line eliminating unneeded clutter from the page. A well-notated score will most likely contain usage of both the grand staff and a single staff. This is practical from publisher, composer, and performer perspectives.

4.2 Sticking

Sticking (or hammering) consideration must be made. A mix of hand to hand, double stroke, and double stop sticking is perfectly acceptable. As stated by composer Reginald Smith Brindle in his book *Contemporary Percussion*, “It is therefore necessary for composers to imagine how their music will be played, to foresee what difficulties will arise, and if possible to eliminate them.”³⁴

Sticking can be notated if a certain rhythmic “feel” is desired. Sticking decisions are generally left up to the performer, though there are many examples of performance editions, those edited by marimbists, which include detailed stickings. If a piece involves the simultaneous use of multiple mallet types (soft and hard) indications can be incorporated as described below. If sticking indications are needed, the following guidelines should be followed. With two mallet passages, right and left hand are notated with “R” and “L” above or below the note. In four mallet passages the mallets are numbered 1-4 from left to right (henceforth referred to in this way). As stated, notating sticking is not advisable and especially holds true when using a grand staff to notate left and right hand, which can be inelegant for the performer, especially for those who are reading the score in a performance. A suitable example of this can be found in Daniel Levitan’s *Baroque Suite* showing multiple repetitions of the same note (A4), notated on different staves, as shown in example 4.3.

³⁴ Brindle, Reginald Smith, *Contemporary Percussion*, New York: Oxford University Press, 1991, p. 26.



©2001 Keyboard Percussion Publications
 by Marimba Productions Inc.
 Used with permission.

Example 4.3: Baroque Suite by Daniel Levitan, mm. 7-9. Notated sticking using a grand staff.

As stated before, a practical reason to notate sticking would be if the composer desires to have different mallets types or implements in each hand (i.e. soft mallets in the left and hard in the right). In this case the sticking must be clearly notated in the score.

This is shown in Example 4.4 in Raymond Helble’s *Marimba Prelude No. 1*.

©1977 Studio 4 Music
 by Marimba Productions Inc.
 Used with permission.

Example 4.4: *Prelude No. 1* by Raymond Helble, mallet symbol from score, mm. 1-2.

Notated sticking due to varying mallets.

As shown above, the sticking is notated using the standard mallet symbols (see mallets section) and the standard numbering left hand 1 & 2, right hand 3 & 4. This should be the equivalent of composing for two different instruments (one in each hand) simultaneously.

4.3 Roll Notation

In standard marimba playing, attaining absolute sustain (with mallets) the way a wind instrument or vocalist does is not possible. Often composers think that a roll will sound “choppy” or “tattered.” As stated by percussionist Robert Paterson, “It is my experience that bad-sounding rolls are often the result of factors that can be fixed or compensated for such as poor mallet choice (i.e. soft yarn mallets played *forte* on the top octave of a marimba), an instrument with dead bars or inappropriate rolls speed.”³⁵ The solution is to perform a tremolo or roll providing the illusion of sustain.³⁶ Rolls can be a common concern among composers and should be notated with as much simplicity as possible and with a clear indication of the desired rhythm. The use of three slashes through the stem of any note indicates the note is to be played as an unmeasured roll. A tremolo/trill symbol (or the French “rl” for roulée) is not preferred and should be explained in the performance note if used. The “z” symbol is typically reserved for lateral or ripple rolls (see roll types in chapter 6). Multiple bounce rolls or “buzz” rolls of the snare drum are not possible on marimba because there is no natural rebound of the mallet from the bar and should not be notated.³⁷ If a specific number of notes or attacks is desired the, rhythm should be written out in full. As stated by Nancy Zeltsman, rolls should not be indicated using the two note “orchestral” style but rather with the use of three slashes over a combined stem.³⁸ If a specific note is desired to start the roll it should be notated above the staff. In Figure 4.2, taken from Zeltsman’s, website, the proper and improper notation is indicated.

³⁵ Paterson, Robert A., *Sounds that Resonate: Selected Developments in Western Bar Percussion During the Twentieth Century*, DMA Diss., Ithaca: Cornell University, 2004, p. 137.

³⁶ For a description of roll types see “Rolls” in the performer technique section on page __.

³⁷ Solomon, p. 35

³⁸ Zeltsman, (Accessed February 20th).

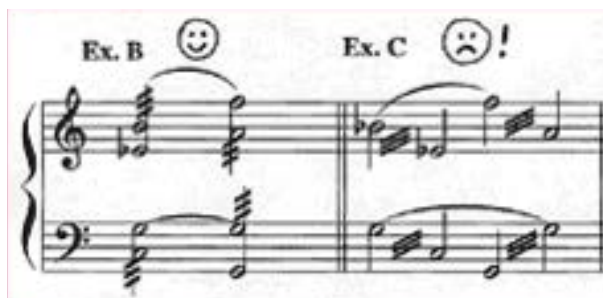

Figure 4.2: Proper roll notation.³⁹

If the composer wants the roll to start in a specific way it should be explained briefly in the score and/or with more detail in the performer's notes. Most marimba players will start rolls in one of two ways by default: either they will try to obscure or "blur" the start of the roll by initiating each note at a slightly different time, or they will start each note at the same time (double/quad stop). This is shown in figure 4.3.



Figure 4.3: Two common ways of starting rolls written as if it were thirty-second notes.

One notational solution, proposed by Zeltsman, is to use a grace note immediately preceding the rhythmic value or to use an arpeggio marking as shown in Figure 4.4.⁴⁰ An arpeggio line may also be used if this is the desired effect.

³⁹ Ibid.

⁴⁰ Ibid.



Figure 4.4: Notating different starts to the roll. If grace notes are used to indicate a varied start of the roll, it should be noted in the performers notes that this is the composer's intention.⁴¹

The performer typically determines roll speed. One can equate roll speed to the vibrato of a singer. The ultimate goal of a roll is to maintain a sustained sound and this is the starting point for most performers. In general, roll speed will be dictated by register and mallet choice. The higher the register the faster the roll will be. Hard mallets will require a faster roll to achieve sustain.⁴²

There are certain situations when rolls do not work well on the marimba; extended roll passages with varied dynamics, the upper range of the marimba, and chords containing multiple compound intervals. Extended passages with wide dynamics can sound monotonous and over time will sound like individual notes. The upper range of the instrument simply does not resonate as much as the middle and lower range of the instrument. As well, chords with a wide voicing will make the individual beating of each hand protrude out of the texture.⁴³

⁴¹ Ibid.

⁴² Paterson, Robert A., *Sounds that Resonate: Selected Developments in Western Bar Percussion During the Twentieth Century*, DMA Diss., Ithaca: Cornell University, 2004, p. 138.

⁴³ Daughtrey, Nathan, "The Marimba Roll: A Necessary Evil?," *Percussive Notes*, July 2014: 37.

4.4 Articulations

Articulations are incredibly important and should not be overlooked from a compositional standpoint. Performers welcome all standard musical and phrase markings. Though the marimba is a struck instrument, the length and quality of the bars can be controlled to a certain degree. Not only will composing with varying articulations result in varying sound qualities, but the ensuing ancillary gestures will affect the audience's perception of the sound, as concluded by Michael Schutz and Fiona Manning in their study, *Looking Beyond the Score: The Musical Role of Percussionists' Ancillary Gestures*.^{44 45} Schutz and Manning show us that the follow-through of a given stroke on the marimba will have an effect on the perceived length of resonance of the note that is struck. For example, even if a bar is struck quickly, a slow follow-through will give the illusion of a longer sound.⁴⁶ Although not notated, many performers will apply this technique when striving to create long notes. This is primarily a visual concern and only comes into play in live performances, but it is nevertheless important to a performer's interpretation of a given piece.

Each performer interprets articulations in different ways. As a general rule, the length of the articulation determines the speed of the stroke (both before and after the note is struck). Accents are played with a higher velocity than normal (marcato with even higher velocity than accents), tenuto is played with more weight in the stroke, and staccato is played with a short, quick stroke. Staccato markings are a special case and could be interpreted in three different ways. When discussing staccato markings in her

⁴⁴ Zeltsman, Nancy, *Four-Mallet Marimba Playing*, Milwaukee, WI: Hal Leonard, 2003 pp. 57-58.

⁴⁵ Schutz, Michael, and Fiona Manning, "Looking Beyond the Score: The Musical Role of Percussionists' Ancillary Gestures," *Society for Music Theory* 18, no. 1 (April 2012).

⁴⁶ Ibid.

book *Four-Mallet Marimba Playing* Nancy Zeltsman states, “I sometimes play them as dead strokes (completely dampening the note with the mallet head as it is struck) or quasi-dead strokes (dampening, but not pressing as hard, so the resonance isn’t quite as choked). Another way I make a note sound short is to approach it with a very quick down stroke and upstroke.”⁴⁷ Because staccato markings can be interpreted as dead strokes, it is advisable to note whether or not this is the intent somewhere in the score or in the performance notes. (For further information on dead strokes, see section in chapter 7: extended techniques).

Slur usage is advisable when composing roll passages to denote when a blending or pedaled sound is desired. They should also be used to denote the phrase or to show that the composer desires an unbroken stream of sound. In a transcription of Henry Purcell’s *Finale from Dido and Aeneas* the use of slurs is shown in example 4.5.



Example 4.5: *Finale from Dido and Aeneas* by Henry Purcell, arr. for marimba by Joseph Millea mm 5-7. Use of slurs during a roll passage (all notes are rolled).

In the example above, at the beginning of measure 5, the performer may initially attack all four notes at once and then blend them with a hand to hand roll through beat 3. A brief break in the sound (similar to a breath mark) would occur before the start of beat 4. The

⁴⁷ Zeltsman, p. 57.

same thing occurs starting on beat 3 of measure 6 and continues until beat four of measure 7. Slurs are also effective when using a forte-piano indication. The roll can be delayed from the initial strike, giving an indefinite start in which the sound seemingly emerges from silence.⁴⁸

4.5 Embellishment

Notational devices that fall into the category of embellishments include grace notes and standard glissandi. As with any instrument these are often considered ornamental to their accompanying parent note. Interpretation of these can differ from performer to performer.

The way grace notes are played is different for marimbists than for other instrumentalists due to the fact that most marimba players studied snare drum as beginning percussionists. Typically, grace notes in snare drum (i.e. flam, ruff, or drag), are played much faster and closer to their parent note than other instrumentalists. Because of this, it is important to make the distinction between an appoggiatura and acciaccatura for percussionists. Standard interpretation of an acciaccatura (a grace note with a slash through it) for percussionists is to play the notes as fast as possible into the parent note. This is especially popular in the Japanese solo marimba literature. An excerpt from Yasuo Sueyoshi's *Mirage pour Marimba* is shown in example 4.6.

⁴⁸ Solomon, p. 39



© 1975 by ONGAKU NO TOMO SHA CORP.
 Kagurazaka 6-30, Shinjuku-ku, Tokyo, Japan
 Reprinted by permission.

Example 4.6: *Mirage pour Marimba* by Yasuo Sueyoshi, Section a – 4, use of acciaccatura grace note.

With the appoggiatura style of grace note, more time is typically allowed in the execution. For example, a group of five chromatic grace notes is played with just two mallets. This is shown in figure 4.5. The use of “2” and “3” below the grace notes indicates the sticking to be used.



Figure 4.5: Use of appoggiatura grace note.

Standard glissandi are notated the same way a glissando is notated in a piano score. The starting note(s) with the required rhythm and (if desired) an ending note are given. This can be done with a straight line or an arpeggiated line. An example of this can be found in Gene Koshinski’s *Variations after Viñao* (example 4.8).



© Copyright 2007 by Bachovich Music Publications.
Reprinted by permission.

Example 4.7: *Variations after Viñao* by Gene Koshinski, mm. 158-159, notation of standard glissando.

A standard glissando is limited to the white keys of the marimba and while a glissando of the entire length of the instrument is possible, the rhythmic duration must be of manageable length.

4.6 Dynamics

All standard dynamic notations can be used when composing for marimba. The most notable feature when considering dynamics is that the dynamic range of the instrument is incredibly versatile. It can go from extremely soft to extremely loud in an instant. As is the case with any instrument, the more technically involved a given passage is the more difficult it is to achieve dynamics at extreme levels.

As was discussed in Chapter 3, weight and articulation must be considered when using extreme dynamics. A hard mallet yields a very bright ‘xylophone’ like sound at the upper end of the marimba: it is brittle in the lower register and may cause damage to the keyboard. The same goes for soft mallets on the upper end, which in extreme cases produces a dull tone. Mallet hardness or softness should not be used to control the amplitude but rather the timbre.

Independent dynamics can be easily executed on the marimba. Splitting the dynamics between each hand or even each mallet can create unique textures. This can be achieved either by varying the height of each hand or playing on different parts of the bar. This is illustrated in figure 4.5.

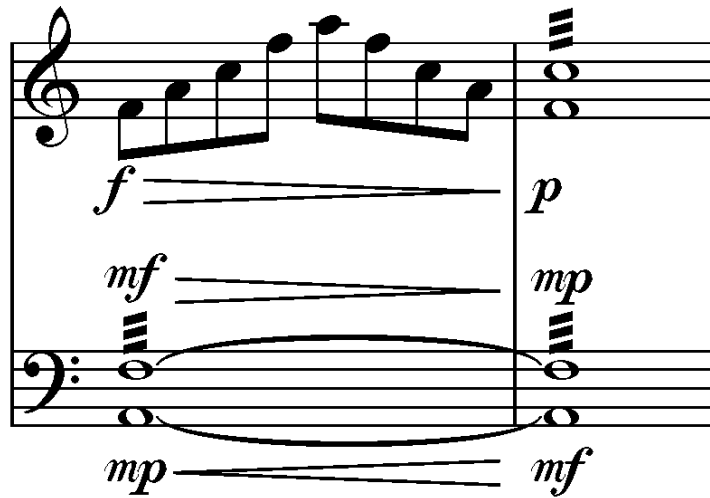

Figure 4.6: Dynamic independence.

In the above example, the player starts with mallet 1 near the nodal point of the bar and mallet two in the center. The left hand mallets switch as the measure goes on.

CHAPTER 5

PERFORMER LIMITATIONS

The overarching purpose of this document is not to limit what composers can do, but to show what possibilities exist and hopefully spark more creative and musically enriching marimba repertoire. However, there are limitations that should be taken into consideration. Many of these limitations have to do with the sheer size of the instrument and its non-tactile nature. Compounding this problem is the fact that marimba players (as with all instrumentalists) vary in their physical size. Other limitations stem from the dexterity needed to wield four mallets at a time or the fact that the accidental bars are raised above the natural bars.

5.1 Extreme Registers and Intervals

Because of the length of the marimba (approximately 8 feet), simultaneous, extreme registral differences should be brief and not require a high degree of technical prowess. While playing the highest and lowest notes on a 5.0 octave marimba (C2 and C7) simultaneously is possible, it requires most performers to bend or squat toward the instrument, limiting essentially all technique. A notorious example of a brief but effective use of extreme register is the final bars of Andrew Thomas' *Merlin* (1985) (example 5.1a).



Music by Andrew Thomas

Copyright © 1985 by Associated Music Publishers, Inc. (BMI)

International Copyright Secured. All Rights Reserved.

Used by Permission

Warning: Unauthorized reproduction of this publication is prohibited by Federal Law and is subject to criminal prosecution.

Example 5.1a: *Merlin II*, by Andrew Thomas, mm. 205-207. Extreme Registers.

With F2 & B2 in the left hand and C6 & C7 in the right hand, this is a distance of approximately six feet between each hand. The piece was commissioned by percussionist William Moersch, who is over six feet tall and has no trouble reaching these notes; for a shorter percussionist such as Nancy Zeltsman, a transposition must be made as shown in example 5.1b.



Music by Andrew Thomas

Copyright © 1985 by Associated Music Publishers, Inc. (BMI)

International Copyright Secured. All Rights Reserved.

Used by Permission

Warning: Unauthorized reproduction of this publication is prohibited by Federal Law and is subject to criminal prosecution.

Example 5.1b: *Merlin II*, by Andrew Thomas, mm. 205-207. Zeltsman Transposition.

In passages such as these an ossia measure is a preferable alternative for flexibility for performers' physical capabilities.

Most marimba players will be limited to an interval of approximately a 9th or a 10th on the low end and approximately a 12th or 13th in the upper register within each hand. As stated by percussionist Nicholas Papador, “Even some professional players, when commissioning new works for the instrument, may specify that passages of active playing should contain no intervals wider than a sixth unless the texture is sparse enough to allow adequate time to prepare intervals such as sevenths and octaves.”⁴⁹ If pitches are notated beyond these ranges, notes either need to be transposed or left out. It is best to offer an ossia measure or parenthetical note in extreme cases.

As chord voicings and melodic lines stretch laterally across the marimba, accurate execution obviously becomes a greater challenge for players. Due to the size and various designs of marimbas, players cannot always see what they are playing. In his book “How to Write for Percussion,” percussionist Samuel Solomon says that when each hand is playing a large interval apart from the other, accuracy becomes an issue. “The reader may try the following exercise: sit at the piano with your eyes focused on middle C and notice the span of your peripheral vision. Without moving your head, observe the range you can comfortably move your hands in both directions and still see what notes you are playing.”⁵⁰ Most marimbists aspire to use peripheral vision to play the instrument. The level of expertise required to perform a particular composition is often dictated by the width of the registration—the wider the chord voicing and melodic span, the more advanced the player will need to be.

Compounding the challenge is the fact that with graduated bars from bottom to top, the distance between the mallet heads changes as the same interval ascends/descends

⁴⁹ Papador, Nicholas, "Observations and Development of Extended Interval Usage in Four-Mallet Keyboard Percussion," *Percussive Notes*, November 2010: 34.

⁵⁰ Solomon, Samuel Z, *How to Write for Percussion*, New York: SZSolomon, 2002, p. 80

the instrument. On a piano, an octave is the same throughout the piano's range; on a marimba there is no consistent interval.

5.2 Extreme Dexterity

Speed and dexterity are considerations that must be made for any instrumentalist, but this is an especially poignant aspect of marimba playing. As Samuel Solomon describes in his book, there are several conditions that can affect the speed of a percussionist; the number of playing surfaces involved and the distance between them, the weight of the implement being used, dynamics, endurance, sticking, and physical balance.⁵¹ An important rule of thumb when composing for marimba is to remember that marimba players do not have the same dexterity as pianists. Passages, which require extreme independence of all four (or six) mallets, may be unreasonably demanding for most players. This especially holds true when changing manuals (white and black keys). Months of practice for a relatively brief passage can be frustrating for a performer. Depending on the composition's harmonic language and rhythmic style, another method of notation, such as graphic or aleatoric scoring, may be warranted. Solomon states, "By composing on piano with just thumbs and pinky fingers, the logistical problems that keyboard percussionists face will become immediately apparent."⁵² An example of extreme dexterity posing a problem is found at the end of Yasuo Sueyoshi's *Mirage pour Marimba*. This is shown below in example 5.2.

⁵¹ Ibid, p. 12.

⁵² Solomon, p. 79.



© 1975 by ONGAKU NO TOMO SHA CORP.
Kagurazaka 6-30, Shinjuku-ku, Tokyo, Japan
Reprinted by permission.

Example 5.2: *Mirage pour Marimba* by Yasuo Sueyoshi, mm. 128-130. To perform this as written would require each hand to perform 16th notes at quarter = 160+. Most percussionists can play 16th notes between 100-120 BPM.

Shown here we see an accelerando into double stops. As stated by percussionist Brian Zator in his analysis of *Mirage*, “At this extreme tempo, this measure is almost physically impossible to play.”⁵³ Most marimba players continue the hand-to-hand continuity from m. 129 through m. 130. However, Zator goes on to say that the composer insists the passage be played as is, but admits that the tempo must be slower to be played as written.⁵⁴

5.3 Manuals

Consideration of each manual (white and black keys), especially when writing for four mallets, is essential. The best sound is produced when the bars are struck at or near the center. However, it may be necessary to play on the edges of the accidentals (and naturals). In general the performer decides when to play in the center and when to play on the edges. This is not an issue when a single manual is being used (i.e. C major triad or F# major triad). From a physical standpoint, combining manuals can be problematic.

⁵³ Zator, Brian, "Yasuo Sueyoshi's "Mirage pour Marimba", " *Percussive Notes* 38, no. 2 (2000): 53.

⁵⁴ Ibid

Because the accidentals are raised (approximately 1.5 inches), quick shifts from manual to manual should be played hand-to-hand if possible. Other manual limitations can be related to awkward chord voicing. For example, to play a B major triad, as shown below in figure 5.1, requires the forearms of the performer to be nearly touching. This type of voicing will affect the striking location on each of the bars. See chapter 2.3, Bars and Tuning.

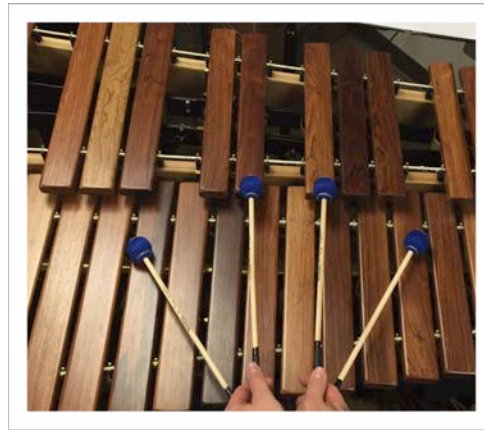

Figure 5.1: B Major Triad, notated and pictured

As shown above, the player has to strain just to hit the notes (much less produce a quality sound). One possible solution would be to place the B3 and B4 in the left hand and D#4 and F#4 in the right. An example of this type of awkward shifting in the standard marimba repertoire is found in Peter Klatzow's *Dances of Earth and Fire*. In example 5.3 below the performer has to strain the right hand/arm to play the upper notes.

the upper 3rds barely audible, like harmonics

© Copyright 1987 by PM Europe.
Reprinted by permission.

Example 5.3: *Dances of Earth and Fire* by Peter Klatzow, mvt. 1, mm. 68-73. Difficult Manual Shifts (treble staff).

The range, though large, is not the difficult part in this passage. It is the way the performer must shift the right hand, awkwardly splitting manuals between the mallets in the right hand. The soft dynamic of this passage makes it achievable but still very difficult. Possible solutions to this passage are to leave certain notes out or to briefly “choke up” on the right outside mallet. To reiterate as Solomon says, composing with thumbs and little fingers will give a clear idea of how difficult manual shifts will be.

5.4 Extreme Octave Shifts

Extreme chord changes and variations in the body position of the performer will require time to shift one’s weight to strike the correct notes and produce a quality sound. This does not just apply to extreme register changes, but certain positions can be awkward. As shown in figure 9, shifts between chords such as root position Bb major triad and a root position B major triad are very problematic.

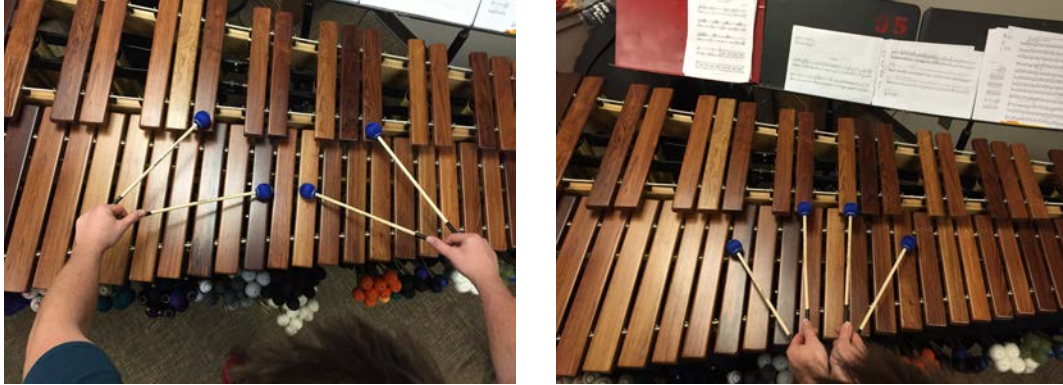

Figure 5.2: Hand positions of Bb major chord (left) and B major Chord (right).

5.5 Kinesthetic and Tactile Considerations

“Therefore, factors such as kinesthetic movement and consistent playing situations are crucial for comfort and especially accuracy. Having an understanding of how percussionists maintain accuracy might prove beneficial for writing complex parts.”⁵⁵

Because the performer is not physically touching the instrument, the need for kinesthetic or muscle memory arises. Most seasoned players will have a good sense of kinesthetic movement, but any given composition contains a unique set of movements. Composers must be cautious when writing complex passages. This does not mean that marimba pieces should consist of mainly ostinato patterns and “groove” based passages. But the importance of a well-designed formal structure cannot be overstated.

5.6 Other Limitations

Performing a double stop (two mallets at the same time) on a single note is not recommended. This will produce a slightly choked or non-resonant sound. A fuller sound is produced with a single mallet striking the bar. Of course, this would be a very interesting effect in terms of extended technique, when used properly.

⁵⁵ Paterson, 117.

CHAPTER 6

MARIMBA PERFORMANCE TECHNIQUES

Over the past century, there have been many technical advances on the marimba. Performers and composers have expanded the instrument's harmonic, melodic and rhythmic capabilities. Chapter 6 will illustrate many of the techniques that have come to be standardized in popular repertoire. While these techniques would typically not be notated specifically, their potential implementation will offer composers many musical ideas.

6.1 Number of Mallets

The number of mallets used by performers generally varies from two to four at once. The use of six mallets is also possible but is technically limiting (see Chapter 7: extended techniques). Composers can specify this but ultimately the number of mallets required for a particular passage should be left up to the performer. From a pedagogical standpoint, four mallets is considered an intermediate to advanced technique, with most percussionists learning this toward the end of their years in high school or as a freshman in college. Beginning players will predominantly be able to use only two mallets at one time. The number of mallets does not necessarily signify the difficulty of a passage of music. Virtuoso marimbist Julie Spencer performs certain works intended for four mallets, such as Gordon Stout's *Two Mexican Dances*, with only two mallets.⁵⁶ Contrary to this, marimba player Nancy Zeltsman states, "I almost always hold four mallets, out of personal preference."⁵⁷ This does not mean all of the music she plays has a chordal

⁵⁶ Spencer, Julie, "The Horizontal Concept of Marimba Technique," *Percussive Notes* 26, no. 1 (1987): 38.

⁵⁷ Zeltsman, 2015.

texture; if a given composition is well-planned for four mallets, it can be used to navigate even the most scalar-type passages.

Playing with two mallets is best suited for simpler passages which don't use three and four note chords, and for fast tempi. The early ragtime xylophone playing of George Hamilton Green is seen as a model for two-mallet performance. Contemporary examples of two mallet playing come in the works of Nebojsa Jovan Zivkovic (*Fluctus*, and *Der Kleine Paganini*) and Gene Koshinski (*Variations after Viñao*, *Afternoon in March*). An example of Koshinski's *Variations After Vinao* is shown in example 6.1.



© Copyright 2007 by Bachovich Music Publications.
Reprinted by permission.

Example 6.1: *Variations after Viñao* by Gene Koshinski, mm. 198-200, Complex writing for two mallets.

Four mallet playing is done with three different grips; Musser/Stevens, Burton, and Traditional. Akin to French and German bows in double bass playing, no one grip is superior. Though there are small advantages and disadvantages to each, they are all widely used and allow the performer to produce a high quality sound with technical prowess.

Musser/Stevens grip is the only standard grip that does not have the mallets cross over or come into contact with each other. The ring and little finger, support the outside

mallets, while the inside mallets are supported by the thumb, index, and middle fingers. Burton grip was developed by Jazz vibraphonist Gary Burton and has been adopted by many classical/contemporary marimba players. This grip requires the player to cross the mallets in their hand. In this case the inside mallet crosses under the outside mallet. Traditional grip, like Burton, requires the player to cross the mallets. The difference is the outside mallet crosses below the inside mallet. Composers will not specify which grip is used in a composition, but should be aware that there are differences between. For example, a player using Burton grip will likely only be able to reach an octave in one hand. With Stevens grip, a larger interval is possible.

6.2 Stroke types

The act of striking the marimba is the primary means in which sound is produced. There are infinite ways to strike the instrument. For two-mallet playing the stroke types can be reduced to double stops, single strokes, and rolls. In four-mallet playing several stroke types have been standardized, most notably in Leigh Howard Stevens' *Method of Movement*.⁵⁸ Because of the breadth and detail of these stroke types, marimba players can navigate even the most technically challenging passages. Hybrid techniques and stroke combinations can be implemented as needed to accommodate harmonic, polyphonic and melodic complexities. Composers should feel empowered to push the envelope, as long as the technique serves the music and musicality is not sacrificed for technical pyrotechnics.

The Independent stroke is used when a single note is struck separately from another note, hence the term. It is a very common stroke. Stevens defines it as "...the

⁵⁸ Stevens, Leigh Howard, *Method of Movement for Marimba*. 5th Edition, Ashbury Park, NJ: Keyboard Percussion Publications, 2000.

ability to strike single (or repeated single) strokes without moving the unused mallet held in that hand.”⁵⁹

The Double Vertical stroke is used when two notes are to be struck at the same time with one hand (a dyad). Both hands utilizing a double vertical can produce four note chords. Dexterity becomes a concern with multiple double verticals in a row. Large interval changes in the same hand should be used with caution. Certain combinations will work better than others. It is best to consult a professional percussionist or marimba player in this situation. An excellent example of double vertical use comes in Nebojsa Zivkovic’s *Uneven Souls* as shown in example 6.2.

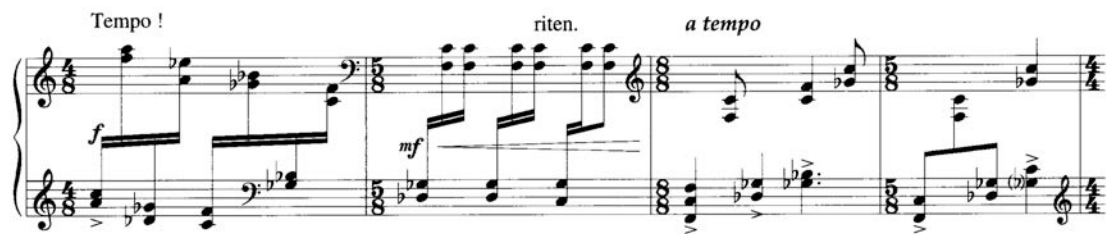

© Copyright 1992 by Ed. Musica Europea
Reprinted by permission.

Example 6.2: *Uneven Souls* by Nebojsa Zivkovic, marimba, mm. 58-61. Use of double vertical strokes.

In the above example a melodic line that is rhythmically varied emerges from the texture, making up the bulk of the thematic material of the piece.

The use of double verticals can also be an excellent tool for balance in an ensemble or concerto situation. In an email correspondence to the author about Richard Rodney Bennett’s *Concerto for Marimba and Chamber Orchestra*, percussionist William Moersch writes, “Still concerned about balance, Richard decided to use more “hand-to-

⁵⁹ Stevens, Leigh Howard, *Method of Movement for Marimba*, 5th Edition, Ashbury Park, NJ: Keyboard Percussion Publications, 2000, p. 26.

hand" marimba writing for the tutti sections and reserve the "one-handed", "AS2" style of marimba writing for the solo moments." The "AS2" style refers to Bennett's work for solo marimba entitled *After Syrinx II*, which Moersch also commissioned. The "hand-to-hand" style that Moersch describes indicates that the writing consists of mostly alternating sticking (left, right, left, right...). In this case, the use of right hand double verticals is prevalent. This is shown below in example 6.3a. The "AS2," style refers to writing that uses more repeated strokes within one hand as well as rolls and softer dynamics. This is shown in example 6.3b. As stated by Moersch, this was done to create more balance between the soloist and the orchestra, during tutti sections.



Example 6.3a: Marimba Concerto by Richard Rodney Bennett, mm. 21-23. Hand to hand writing style for Tutti sections



Marimba Concerto
 Music by Richard Rodney Bennett
 © Copyright 1988 Novello & Company Limited.
 All Rights Reserved. International Copyright Secured.
 Reprinted by permission

Example 6.3b: Marimba Concerto by Richard Rodney Bennett, m. 163 (cadenza). *After Syrinx II* solo style writing.

The single alternating stroke is used when alternating between mallets in a single hand. Stevens defines it as follows: “Quite simply, they are executed as if they were alternating single independent strokes...”⁶⁰ Though the strokes are alternating between each other, they still function independently of each other (i.e. one stroke does not initiate until the other has struck the bar). This technique is useful especially when alternating between notes that are an interval of a 4th or higher or between manuals. Intervals below a 4th are possible but require more energy to achieve a louder dynamic. Gordon Stout’s *Two Mexican Dances* is exemplary of this technique utilizing an interval of an octave. See example 6.4.



©1977 Studio 4 Music
by Marimba Productions Inc.
Used with permission.

Example 6.4: *Two Mexican Dances* by Gordon Stout, mvt. 1, mm. 1-3. Single alternating stroke in left hand.

The lateral stroke is a way of performing two fast strokes in succession with a single hand. Stevens describes them as “...single motions that produce two successive pitches.”⁶¹ This type of stroke is not recommended for beginning literature. The lateral stroke allows for various combinations of strokes in quick succession. In example 6.5,

⁶⁰ Stevens, p. 30.

⁶¹ Ibid, p. 35

Eric Sammut’s *Libertango*, the performer is able to play four successive lateral strokes (triplets) ending on the downbeat of the next measure, among an already quick set of 16th notes.



©1975 Edizioni Curco, used with permission.
 ©2002 Keyboard Percussion Publications
 by Marimba Productions Inc.
 Used with permission.

Example 6.5: *Libertango*, by Eric Sammut, mm. 73-75, use of downward lateral stroke.

Lateral strokes are can be executed in many different ways or “permutations.”

Figure 6.1 shows some possibilities of lateral permutations or stickings. In general permutations that start with an outer mallet (1 or 4) are easier to execute.



Figure 6.1: Possible Lateral Stroke Permutations, numbered and notated on a C major Triad.

Other triplet-based rhythmic options exist as well where a single mallet plays between the lateral strokes of the other hand (i.e. permutation 1, 43 1, 43...). This technique is shown in example 6.6, from *Apo to Kolpo Kassandra* (2012) by David Kosviner. In this example the possible stickings are 4, 1, 2 or 3, 1, 2.

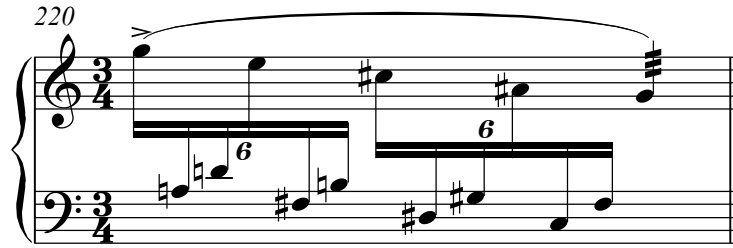

© Copyright 2012 by David Kosviner.
Reprinted by permission.

Example 6.6: *Apo to Kolpo Kassandra* by David Kosviner, mm. 220, lateral stroke using triplet rhythm permutation.

Lateral strokes can be easily moved around the instrument. There is no more limitation to the stroke than other strokes. An illustration of a lateral stroke being moved around the instrument can be found in example 6.7, showing an excerpt from Kosviner's *Apo to Kolpo Kassandra* (2012). In this example the sticking permutation is 1234, and each hand is on a single manual for almost the entire passage.

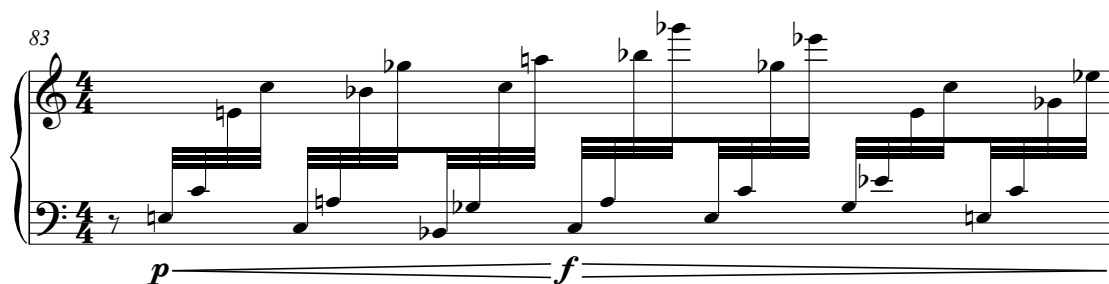

© Copyright 2012 by David Kosviner.
Reprinted by permission.

Example 6.7: *Apo to Kolpo Kassandra* by David Kosviner, mm. 83, lateral strokes moving around the instrument.

A triple lateral stroke is an extension of the double lateral technique. Each hand executes three successive strokes instead of two. With the triple lateral stroke, up to six strokes can be made in succession, in various combinations between the hands. In

example 6.8, Kevin Bobo utilizes this technique in the majority of his work *Ezekiel's Wheel* for Marimba and Tenor Steel Pan.



© Copyright 2010 by PercMaster Publications.
Reprinted by permission.

Example 6.8: *Ezekiel's Wheel* by Kevin Bobo, mm. 159 to 161, use of triple lateral stroke (upper staff).

As stated before, this is considered an advanced technique and should only be used in intermediate-level repertoire and above. Figure 6.2 shows various examples of triple lateral strokes and their notation. As with lateral strokes, there are many combinations of available for the triple lateral stroke. Other possibilities exist. Like lateral strokes, triple lateral strokes can be combined with other stroke types and stickings.



Figure 6.2: Possible Triple Lateral Stroke Permutations, Numbered and notated on C & G.

6.3 Mallet Angle

The angle of the mallet when it strikes the instrument affects the timbre of the sound. If the bar is struck with an angled mallet, the sound produced has less volume but will a much darker tone and a much wider sound envelope in its attack. Varying the mallet angle is especially effective in roll passages. There is not a standard way to notate this, however, the example below from Steven Snowden's *Long Distance* uses a "T" for tip of the mallet and "N" for normal (mallet parallel to the bar) as well as a dotted arrow to show the transition from one to the other. This is done above the staff as shown in example 6.9.

The image shows a musical score for a marimba roll. The notation is on a single staff with a treble clef. The roll starts at measure 10, marked with a dynamic of *ppp*. Above the staff, a dashed line indicates the mallet angle, starting with a "T" (tip) and transitioning to "N" (normal) via a dotted arrow. Below the staff, another dashed line indicates the mallet position, starting with "M" and transitioning to "NP" via a dotted arrow. The roll continues through measures 11 and 12, with dynamics of *p* and *ppp* respectively. The roll ends in measure 14 with an *8va* marking and a triplet of notes.

© Copyright 2013 by Steven Snowden.
Reprinted by permission.

Example 6.9: *Long Distance* by Steven Snowden, Brooklyn mvt. 2, mm. 10-14, notated mallet angle using "T" for tip and "N" for normal part.

6.4 Roll Types

It is not possible to produce a true sustained sound on a marimba (excluding bowing, see extended techniques). Tremolos, frequently referred to as rolls by percussionists, are to be used when a sustained sound is desired. With good technique, a quality instrument and a reverberant performance hall, the illusion of sustained sound is produced quite easily. Though very common, rolls can become cumbersome if not indicated correctly. The following is a summary of the various roll types.

Hand to hand, or traditional rolls can be used in several different ways. With two mallets the performer is limited to alternating hands. With four mallets there are basically two types of hand-to-hand rolls. The first is similar to two-mallet technique but utilizing two of the four mallets in single independent strokes (i.e. left inside and right inside). The second would be an alternating double vertical stroke (two notes in each hand). This is the most common way to sustain three- or four-note chords.

A one-handed or independent roll is the one that oscillates between two mallets in a single hand, leaving the other hand free to do something else. This is considered an advanced technique. The distance between the two mallets in one hand will impact the dynamic range potential. In general, an interval of a fourth or higher is required for louder dynamics. Of course the interval distance changes with the register. A perfect fourth in the lowest octave is the equivalent of a sixth or seventh in the highest octave and should be taken into consideration. An experienced marimba player will not have any difficulty with this technique. See example 6.10. Intermediate players are also capable of this in limited amounts. One-handed rolls are possible at intervals smaller than a fourth but the relative dynamic of mezzo piano is generally the loudest dynamic possible.



© Copyright 2001, Gretel Verlag Dinklage.
Reprinted by permission.

Example 6.10: *Il Canto dei Gondolieri* by Nebojsa Zivkovic, mm. 47 to 49, one handed roll (right hand/treble staff) usage.

A one-handed roll is also possible on a single note. This is done by striking the bar on each edges of the bar for accidentals and the edge closest to the performer and the center for naturals. This is shown in Figure 6.3.



Figure 6.3: One-handed roll on a single note. Accidental (left), Natural (right).

An example of this technique can be found in Richard Rodney Bennett's *After Syrinx II* (1984) as shown in Example 6.11.



After Syrinx II
 Music by Richard Rodney Bennett
 © Copyright 1984 Novello & Co Limited.
 All Rights Reserved. International Copyright Secured.
 Reprinted by permission

Example 6.11: *After Syrinx II* by Richard Rodney Bennett, m. 1, One-handed roll on a single note.

In this example the rolled notes (Bb and Ab) are played with the right hand and all other notes with the left hand (until the feather beam on beat 3).

A ripple roll is a way to use all four mallets “quasi independently.”⁶² This is different from a lateral roll because it is done with a hand-to-hand motion (similar to the double vertical roll) except all four mallets strike the marimba at different times. This type of roll offers a more open texture to the sound. This can be notated, if desired, but advanced players will use this technique at their discretion. Example 6.12 shows a passage utilizing a ripple roll from Libby Larsen’s *Like Blind Men Tapping in the Dark* for one marimba with two performers.

⁶² Boston Conservatory Percussion, *The Ripple Roll*, June 3, 2013, <https://www.youtube.com/watch?v=6CGCYeqT4fo#t=55> (accessed February 22, 2015).



© Copyright 2010 by Libby Larsen.
Reprinted by permission.

Example 6.12: *Like Blind Men Tapping in the Dark* by Libby Larsen, mm. 54-56. Use of Ripple Roll.

Lateral rolls use a set permutation of the lateral stroke (see Lateral Strokes in basic stroke types). It must consist of a combination of two left-hand strokes followed by two right hand-strokes (i.e. 1, 2, 4, 3 or 2, 1, 3, 4). The resulting sound is similar to a ripple roll but with a more defined rhythmic sound. David Kosviner utilizes the lateral roll in his work, *Apo to Kolpo Kassandra* (2012), as shown in example 6.13.

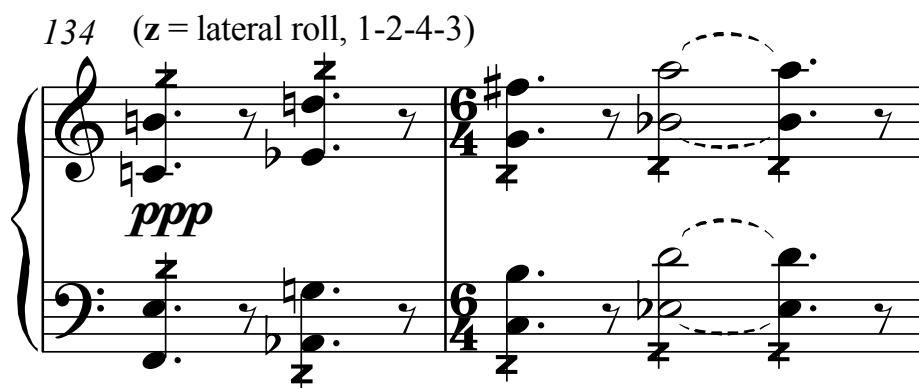

© Copyright 2012 by David Kosviner.
Reprinted by permission.

Example 6.13: *Apo to Kolpo Kassandra* by David Kosviner, mm. 134-135, use of Lateral Roll

The use of the “z” over the stem indicating a lateral roll is not standard but is somewhat common in marimba repertoire. A note in the score, as shown above, or a description of the desired effect in the performances notes is recommended. Single mallet rolls are possible. Necessarily slower than two-handed rolls, they, nevertheless, can be effective at low dynamics and in the lower register of the marimba.⁶³

For Mandolin roll/Split bar roll See Chapter 7: Extended Techniques and Their Notation.

⁶³ Solomon, p. 38.

CHAPTER 7

EXTENDED TECHNIQUES AND THEIR NOTATIONS

There are many techniques for the marimba that can be considered “extended,” and there are many more that have yet to be developed. Some are conventional to most percussionists and some are more specific to the marimba. Great care must be taken when using extended techniques that involve non-standard implements due to the fragile nature of the instrument. For example, wooden drumsticks, hard plastic mallets and metal beaters will cause immediate damage and are not recommended for use on the marimba. Consultation with a professional is advisable if there is any question about the safety of a given technique.

7.1 Dead Strokes

Dead strokes are achieved when the player pushes the mallet into the bar or holds the mallet down immediately after striking it. This is different from mallet dampening as a different timbre is produced in addition to a short articulation. There is not a standard notation for this. Typically composers specify a marking in the performance notes. Composer Peter Klatzow uses a *staccatissimo* marking as shown in example 7.1.



© Copyright 1987 by PM Europe.
Reprinted by permission.

Example 7.1: *Dances of Earth and Fire* by Peter Klatzow, mvt. I, mm. 53-54,
staccatissimo used to notate Dead Strokes.

It is not advisable to use a standard staccato marking as this is used to denote a staccato stroke type (see “staccato” in the Articulation section). It is also commonplace to use a “+” above or below a note head to denote a deadstroke. As illustrated in Steven Mackey’s work *See Ya Thursday* (1993), it is also possible to do a “quasi-dead stroke,” allowing the bar to resonate for a split second before stopping the sound. As stated by Mackey, this creates an “awkward, unbalanced, and irregular sound,” that is a “mechanical failure.”⁶⁴ This effect should be specified in the score or performance notes.

7.2 Dampening and Prepared Marimba

It is possible to dampen and prepare the marimba in various ways. This is an area that has a lot of room for growth in the marimba repertoire. Pre-dampening is the most simple and common form of preparation, but other techniques can be used. “Similar to the way American Composer John Cage prepared pianos, bars can also be prepared in a variety of ways, with everything from rubber bands, clamps, coins, or other objects

⁶⁴ Mackey, Steven. *See Ya Thursday*. Milwaukee: Hendon Music, Inc., 1993, p. 2.

loosely fastened to the bars, and even hunks of oil clay.”⁶⁵ The oil clay can be used to bring out or reduce certain overtones.

Dampening comes in two main types: Mallet and Body. It should be noted that dampening a marimba does not fall into the same vain as Timpani, where rests can typically denote how long to let a note ring and when to dampen. In marimba repertoire, if any type of dampening is desired, it must be specifically notated in the score.

Mallet dampening is quite common in jazz vibraphone playing and can also be applied to marimba playing. The concept is to use a mallet as a dampening device on a bar after it is initially struck by another mallet. In doing so, the bar’s resonance is cut off before its natural decay takes place. This is different from a dead stroke, which does not allow the bar to resonate at all. The standard way of notating this is with an “x” shaped note head on the count that dampening is desired. Composer Daniel Levitan made great use of this in his music, specifically his *Marimba Quartet*, as shown in example 7.2.



©1996 Keyboard Percussion Publications
by Marimba Productions Inc.
Used with permission.

Example 7.2: Marimba Quartet by Daniel Levitan, mvt. I, player 1, mm. 9-10, use of “x” shaped note head to denote mallet dampening.

Hand dampening is also a possibility, either preparing the bar with a free hand (or palm if both hands are being used), or dampening after the bar is struck. In either case the performer will need appropriate time to execute this technique.

⁶⁵ Paterson, 218.

Body dampening is less common and is limited to the performer’s side of the instrument, typically the “white keys.” Pressing one’s body against a specific note and then striking the same note with mallets is how this technique is typically performed. This is notable in Eric Sammut’s *Libertango*, as shown in example 7.3.

Damp B with the body

©1975 Edizioni Curco, used with permission.
 ©2002 Keyboard Percussion Publications
 by Marimba Productions Inc.
 Used with permission.

Example 7.3: *Libertango* by Eric Sammut, mm. 44-45, use of body dampening.

To reiterate, this technique is not very common and thus there is no standard way of notating this. The above example shows the use of a horizontal line (similar to a pedaling mark) with accompanying instructions.

Prepared muting of the marimba is typically done with a rolled-up towel or soft material placed under the front end of the accidentals and above the back end of the naturals. Many composers, including Nigel Westlake in his work *Omphalo Centric Lecture* and Stuart Saunders Smith in his work *The Authors*, used this type of dampening technique. The sound created with muting is a quicker release time in the sound envelope. In Smith’s case, he calls for a strip of cardboard placed along the inside edge of the bars, giving the marimba a typewriter effect when struck. As suggested by Solomon, coins and paper clips are other options for preparation, and tin foil may be played over certain

resonators to generate a buzz effect.⁶⁶ In Andy Akiho’s *LigNEous I* for Marimba and String quartet (2010), he calls for the marimba player to wrap a rubber band around a specified marimba bar allowing the player to perform a type of Bartok pizzicato on a given note.

7.3 Mallet Shafts

Playing with the shafts of the mallet can add a distinctive color to a work. Beyond simply clicking the shafts together, a number of techniques have been integrated into the literature. When mallet shaft usage is required most players use rattan-shafted mallets for their durability. This is found in Leigh Howard Steven’s work *Rhythmic Caprice*. In Stevens’ piece, three techniques are used: shafts are used to strike directly on the bars, combinations of shafts and mallet heads are used to generate “marimshots” and “splash/clusters” are created in which five notes in the accidental manual are played at the same time via a shaft laid flat and perpendicular over the bars. These techniques are shown in figures 7.1a and 7.1b.

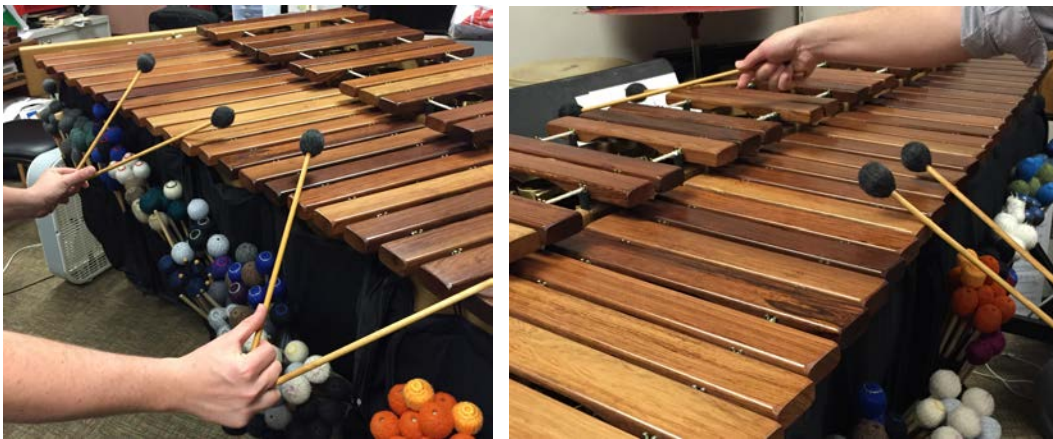

Figure 7.1a: Mallet shaft played struck directly on the bars

⁶⁶ Solomon, p. 88.



Figure 7.1b: *Rhythmic Caprice* by Leigh Howard Stevens, “Splash/Cluster” placed over C#, D#, F#, G#, and A#.

There is no standard notation for these techniques but Stevens utilizes an “x” shaped note head for shaft on bars and a diamond shaped note head for “marimshots.” For any case of shaft usage care must be taken to ensure the time change from manual to manual is reasonable.

It is also possible to play a one-handed roll using the shaft of a mallet. Composer and percussionist Casey Cangelosi has done this in his work *White Knuckle Stroll* for solo marimba. This can be done using the upper and lower halves of the mallet shaft as striking points over an accidental. It could also be done over the naturals if the mallet position is reversed. See figure 7.2.

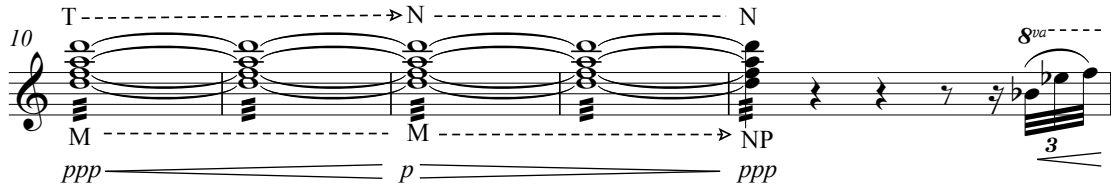

Figure 7.2: One-handed roll with shaft of the mallet

This technique, like in Stevens' work, is notated using an "x" and a standard three-slash tremolo marking.

7.4 Nodes

Playing on the nodal points reduces the resonance of a bar and the harmonic content of its timbre. The resulting sound, generally considered undesirable, is devoid of the fundamental pitch and (depending on the mallet choice) the "thud" of the mallet striking the wood. This can be used to create an extreme change in texture or to drastically reduce volume. There is not a standard way of notating this but Steven Snowden found an adequate solution in his work *Long Distance* for Percussion and Electronics (2013), which is shown in example 7.4. Snowden uses "M" for the middle of the bar and "NP" for the nodal point of the bar below the staff. A dotted line indicates the transition from one to the other.



© Copyright 2013 by Steven Snowden.
Reprinted by permission.

Example 7.4: *Long Distance* by Steven Snowden, *Brooklyn* mvt., mm. 10-14, notation of Playing on nodes (below staff).

7.5 Harmonics

Harmonics can be generated, similar to those produced by stringed instruments. Marimba bar harmonics produce a pitch two octaves above the fundamental. When a bar is slightly muted in the center, with a finger or mallet, and struck near the nodal point a harmonic is produced. This is typically only effective in the lower register and is especially effective when using a bow.⁶⁷

7.6 Bowing

Like most resonant percussion instruments, the marimba can be bowed. Traditionally this is done with a double bass bow, but bow type should be left up to the performer. This can only be done on the outer sides of the instrument (white keys on the player’s side and black keys on the audience side). This limits the speed at which the player can change between some notes. Generally, lower notes are easier to bow than higher notes. Bowing can simply be indicated as it would in a violin part: “arco” at the start of the bowed passage and “norm” or “mallets” when mallets are required. Symbols can also be used as shown in figure 7.3.

⁶⁷ Solomon, p. 87.

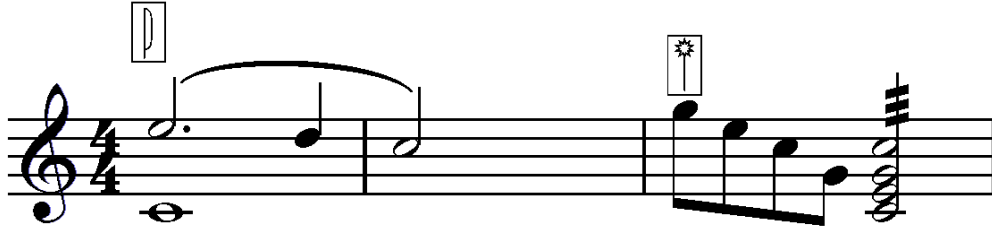

Figure 7.3: Symbols for bowing and mallets, shown above the staff, bowing in mm. 1-2 and mallets in 3.

7.7 Fingers/Fingernails

Playing with fingers directly on the bar offers a textural option (albeit a soft one). This technique is most effective in the lower register of the instrument.⁶⁸ When writing for fingers, an approach similar to that used with two-mallet work is appropriate. More than two notes with fingers are possible, but the interval should be limited to a third (or fourth in the highest register). The use of fingernails is notated in the same way as the use of fingers. This technique should be limited to lower dynamics, as damage to rosewood is possible. As percussionist Robert Paterson states, “Some percussionists do not like touching marimbas or xylophones with bare hands or even fingers since sweat is thought to wear away the finish of the bars. It is always wise to ask the percussionist first if this effect will be possible before writing the part.”⁶⁹ Examples of finger use can be found in Avner Dorman’s *Udarep Akubrad* (2001), and examples of fingernail use can be found in Hans Werner Henze’s *Five Scenes from the Snow Country* (1978). The length of fingernails will of course vary. In his work *Zwei Stucke fur Marimbaphon solo: Laudate*

⁶⁸ Paterson, 204.

⁶⁹ Ibid, 205.

lignum (1980), Werner Heider indicates “...that the percussionist should use fingernails as much as possible, but using fingers alone is adequate.”⁷⁰

7.8 Frame and Resonators

Playing on the frame of the instrument is another sound option. In example 30, Mark Ford uses the frame of the marimba extensively in *Stubernic* (1988). In the score Ford directs the players to play on the “large fiberboard endpiece of the marimba.” Today the only common model that has a large endpiece is the one manufactured by Musser. Ford specifies five different sounds: shaft of the mallet on the audience edge of endpiece, shaft of mallet on bottom edge of endpiece, and three pitches on endpiece (low, medium, and high). Each of these is notated with “x” shaped noteheads. On frames that do not have a fiberboard endpiece, this technique may not be possible and thus a creative solution such as wood or log drums could be substituted. In Ford’s *Afta-Stuba* (2000), he simply specifies the frame end piece as one sound and does not specify different timbres. The example from the performances notes of *Stubernic* (1988) is shown in example 7.5.

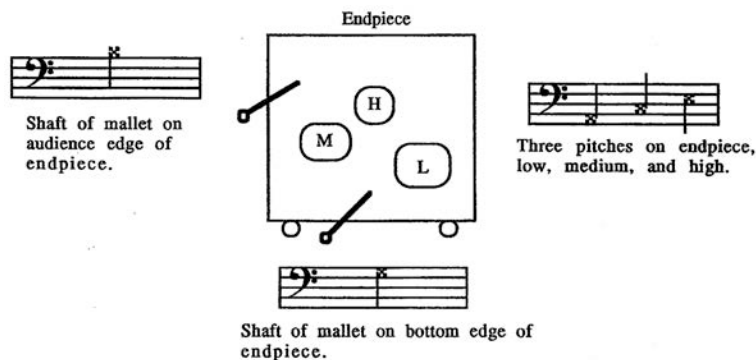

© Copyright 1995 by Innovative Percussion Inc.
Reprinted by permission.

Example 7.5: *Stubernic* by Mark Ford, use of frame (diagram from performance notes)

⁷⁰ Ibid, 206.

Using the marimba resonators to produce sound is definitely feasible. They can be struck or scraped like a large guiro. As they are typically made of metal (aluminum or brass), they can be played with a slightly harder implement (i.e. dowel, mallet shaft, light drumstick) than would be used on the bars without sustaining any significant damage. It should be noted that although the resonators are made of metal, the resonance when struck is very short. In example 31a and 31b from Andy Akiho's *LigNEouS 1* for marimba and string quartet (2010), the resonators are struck in two places; the top, in the gap between the accidentals (example 7.6a), and a glissando on the resonators (example 7.6b).

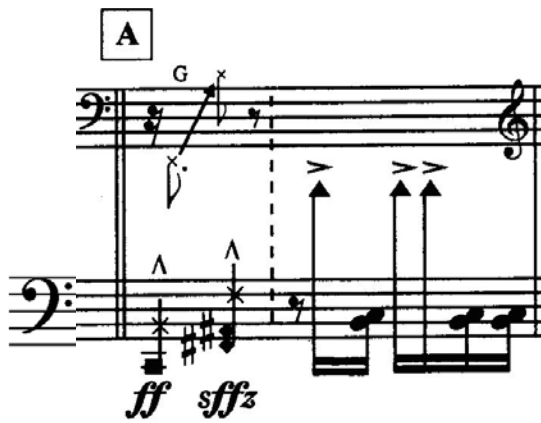

© Copyright 2010 by Aki Rhythm Press.
Reprinted by permission.

Example 7.6a: *LigNEouS 1* by Andy Akiho, marimba part, mm. 27, use of resonators (triangle notehead), pictured left.



© Copyright 2010 by Aki Rhythm Press.
Reprinted by permission.

Example 7.6b: *LigNEous I* by Andy Akiho, marimba part, mm. 29, use of resonator glissandi (beat 5).

When using the resonators there will be subtle differences at the lowest register due to the difference in resonator shape. Though this difference is minimal it will affect the consistency of sound between different instruments.

Another possibility for resonator use is blowing into them through the gaps in the bars. The player should be oriented between two notes and blow at an angle into the desired resonator. For example, if the note desired is D, the player will stand between C and D and blow to the right. Because the resonators are tuned to the bars the effect produced is like a large pan flute (though only one note is possible at a time). An example can be found in Emmanuel Séjourné's percussion ensemble piece *Sosso-Bala* (2007).

7.9 Mandolin/Split Bar Rolls

Mandolin rolls are a tremolo effect that involves two mallets on either side of a marimba bar. With two mallets in one hand, the roll is produced by placing one mallet is placed on top and the other on the bottom of the open end of a note (typically white keys only). With a quick up and down motion a single note tremolo is generated. These are called a mandolin roll because of its similarity to the strumming technique on the

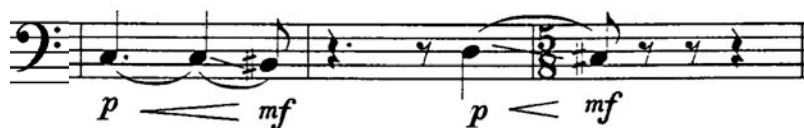

© Copyright 1990 by C. Alan Publications.
Reprinted by permission.

Example 7.8: *Evening's Sabres* by Philip Carlsen, Player 2, mm. 230-232, pitch bend/
glissando.

When bowing is not possible, a pitch bend glissando can be done with a hard yarn or rubber mallet. The performer either executes a one-handed or mandolin roll while pressing the bending mallet into the bar and sliding it from the node towards the center. In doing so, the pitch will be bent down approximately one half-step. An example of this can be found in Salvatore Sciarrino's *Il Legno e la Parola* (2004), which is similar to the example in figure 7.4.

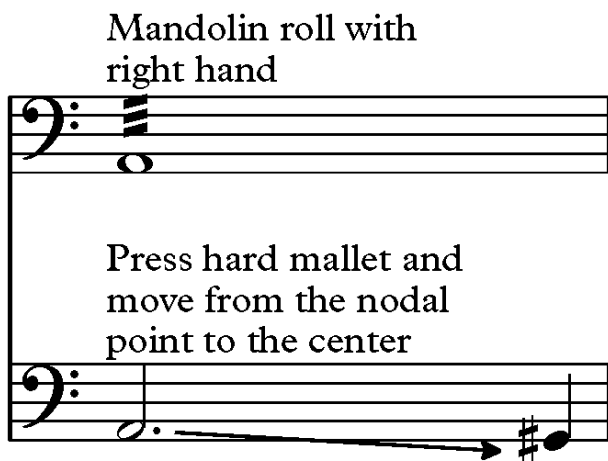

Example 7.4: Notated pitch-bend glissando with a mandolin roll.

7.11 Six Mallets

The use of six mallets (with both Stevens and Burton grip) is possible, but this technique severely limits the technical flexibility of the performer. Independence of each mallet and the ability to change intervals, though not eliminated, is reduced. Keiko Abe has written several works using six-mallets and composer/percussionist Robert Paterson, a pioneer of the six-mallet technique, has written many works utilizing six mallets. A detailed description of the six-mallet technique can be found at Paterson's website (<http://robertpaterson.com/introduction-to-my-six-mallet-technique/>) To give an accurate representation of writing for six mallets composers should consider Samuel Solomon's rule of playing the part on piano with thumb and pinkies and modify it to include the index fingers, as well. An excellent sample from Keiko Abe's *Galilee Impressions* (2004) is shown below in example 7.10.

The image shows a musical score for six mallets, measures 16-18. The score is written for a grand piano and consists of two staves: a treble clef staff and a bass clef staff. The tempo is marked 'Meno mosso'. The score includes various performance instructions: 'rit.' (ritardando) at the beginning, 'Long' (long note) above the first measure, 'espressivo' (expressive) above the second measure, and 'poco rit.' (poco ritardando) above the final measure. Dynamics include 'sub. pp.' (sub-pianissimo) in the first measure, 'p' (piano) in the second, 'mf' (mezzo-forte) in the third, and 'p' (piano) in the fourth. A '10:2' ratio is indicated above the third measure. The score features complex rhythmic patterns with many beamed notes and rests, characteristic of six-mallet percussion writing.

© Copyright 2004 by Xebec Music Publishing Co.
Reprinted by permission.

Example 7.10: *Galilee Impressions* by Keiko Abe, mm. 16-18, exemplary six-mallet composition.

7.12 Alternative Implements

Using implements other than standard mallets is possible, but extreme care must be used to prevent damage to the instrument. Hard objects (metal and wood) are not

recommended and will likely cause damage to the bars. If a hard object is necessary, then it should be utilized in a delicate manner. In Kunsu Shim's work entitled *marimba, bow, stone, player* (1993), the performer is asked to shift small stones to different places on the bars. Because of the delicate nature in which the stones are handled, there is no potential for damage. In Jan Bach's work *Woodwork* (1970) he calls for a notched stick (wooden dowel with notches cut in it).⁷¹ In general, alternative implements should only be used if they are either soft or lightly weighted. The notation of these implements is not standard; they simply require a note in the score when the effect is desired, similar to *arco* and *pizz* in string playing. Below are some common alternative implements.

Brushes (used most typically in jazz drumset), though made of metal, are light enough to be safely used. The sound produced is a light, brief, scrape of the bar. An example of brushes being used on the marimba can be found in Tan Dun's *Silk Road* (1989) for Percussion and Vocalist and Christopher Deane's marimba quartet *Vespertine Formations* (2003). Because of their linear shape, using brushes to execute a mandolin/split bar roll is also an effective tool.⁷²

Bundle Rods (sometimes referred to as 'Hot Rods' or Rute) are a group of thin wooden dowels held together. They are typically used in drumset playing in lieu of normal drumsticks due to volume constraints. On marimba these will produce an articulate wooden sound (similar to a Bartok pizzicato). An exemplary example of bundle rods/rute use on marimba can be found in Michael Udow's *Tennei-Ji* (1999).

Slap mallets are used when a distinctive "slap" or nearly pitch-less sound is desired. Marimbist Keiko Abe used these mallets in her interpretation of Shin-ichiro

⁷¹ Paterson, 211.

⁷² Paterson, 204.

Ikebe's *Monovalence I* (1972). In the score, Ikebe calls for a very soft mallet, "such as a mallet padded with woolen yarn; the sound almost pitchless but tapping." This type of mallet is especially effective on the low end of the instrument.

Thin, lightly weighted wooden dowels can be used when the sound of a stick is desired. The ends, which strike the bars, would need to be wrapped in a layer or two of moleskin to avoid damage to the bars. An example of this can be found in Andy Akiho's *Ligneous I* (2010).

Cluster mallets can often be found in the music of William Kraft. They are mallets that span the width of multiple bars, which he stipulates to be played at once. There is no manufacturer for these; however, the performer can easily fabricate them.

Hybrid mallets are useful in multiple percussion settings. A hybrid mallet is somehow modified to produce a quality sound on marimba and another instrument. For example, in Toru Takemitsu's *Rain Tree* (1981), the marimba players are asked to perform on marimba and crotales. This is problematic since the crotales must be played with a hard plastic or metal mallet. This is not an option on marimba, as it will cause immediate damage to the bars. The solution is to create a hybrid mallet that can strike both surfaces effectively. In figure 7.5, a marimba mallet with a round screw inserted into the top of the mallet is shown.



Figure 7.5: Hybrid Marimba/Crotale mallet.

The hybrid marimba/crotale mallet is a standard marimba mallet with a round-headed screw glued into the top of it. The screw is used to strike the edge of the crotale disk, while the marimba mallet functions in a standard way. One could also glue a small brass mallet but this is not as cost effective.

In Christopher Deane's *Vespertine Formations* (2003) for marimba quartet, he calls for standard medium hard marimba mallets to be combined with brushes. The effect is an emulating the fluttering sounds flocks of birds in the sky. Using a roll of tape to separate the mallet shaft from the brush shaft, allows the mallet to play through the brush. This is illustrated in figure 7.6.



Figure 7.6: Hybrid mallet/brush, designed by Christopher Deane for his work *Vespertine Formations 2003*).

Most hybrid mallets are not manufactured commercially and will need to be constructed by the performer. Where construction is required it is best include a list of suggested materials and instructions on how to construct what you are looking for.

CHAPTER 8

CONCLUSION

The importance of newly written repertoire for the marimba cannot be overstated. The Instrument fits so well in all musical contexts including classical, contemporary, avant-garde, jazz, and rock. Up to this point, marimba players themselves have provided much of the repertoire. While this has greatly furthered the technical possibility, created general enthusiasm, and filled the wide repertoire gap of the instrument, performers are typically not trained as composers, just as composers are typically not trained as performers.

To reiterate, his guide is not intended as an orchestration text, suggesting ways to write for the instrument, rather, it illustrates through examination of well-known solo and chamber works how selected composers have effectively written for the instrument. However, this examination poses only a glimpse of the marimba repertoire. There are many more magnificent works for marimba that were not mentioned in this document. Should questions arise concerning existing repertoire it is best to consult with a professional percussionist or marimba player. There are many graded repertoire lists posted by professionals such as Nancy Zeltsman, on their website.⁷³

The concepts presented in the document are by no means binding. Percussionists are already well adept at performing works that stretch the boundaries of possibility (Xenakis' *Dmaathen*, for example). For years marimba performers have been found ways of making the marimba a virtuosic instrument, but it is the creativity of the composers that drives this. If you feel strongly about what you are composing then the rules and

⁷³ http://www.nancyzeltsman.com/recommended/nz_recsolombarep.pdf

limitations presented in this document are secondary. In the end, well thought out composer-performer collaborations yield great results.

REFERENCES

- Blades, James. *Percussion Instruments and their History*. London: Faber and Faber Limited, 1984.
- Boston Conservatory Percussion. *The Ripple Roll*. June 3, 2013.
<https://www.youtube.com/watch?v=6CGCYeqT4fo#t=55> (accessed February 22, 2015).
- Brindle, Reginald Smith. *Contemporary Percussion*. New York: Oxford University Press, 1991.
- . *Musical Composition*. New York: Oxford University Press, 1986.
- Chenoweth, Vida. *The Marimbas of Guatemala*. Louisville, KY: University of Kentucky Press, 1974.
- Colton, Michelle. *Typologies of Movement in Western Percussion Performance: A Study of Marimbists' Gestures*. DMA Diss, Faculty of Music, University of Toronto, Toronto: Michelle Colton, 2013.
- Conklin, M. Christine. "An Annotated Catalogue of Published Marimba Concertos in the United States from 1940 - 2000." *Thesis*. Norman: University of Oklahoma, 2004. 1.
- Daughtrey, Nathan. "The Marimba Roll: A Necessary Evil?" *Percussive Notes*, July 2014: 37.
- Eyler, David. "The Hurtado Brothers' Royal Marimba Band of Guatemala." *Percussive Notes* 31, no. 3 (February 1993): 48.
- Fang, I-Jen. "*The 1986 National Endowment for the Arts Commission: An Introspective Analysis of two Marimba Works, Reflections on the Nature of Water by Jacob Druckman and Velocities by Joseph Schwantner, Together with three Recitals of Selected Works by Kekio Abe, Christopher Deane, Peter Klatzow, Wayne Siegel, Gitta Steiner, and Others.*" *DMA Diss*. University of North Texas, August 2005. 3-10.
- Gartner, Kurt. "Nathaniel Bartlett: Modern Marimba3 Combining marimba and computer-generated sounds." *Percussive Notes*, April 2008: 14-15.
- Haldeman, Michael Edward. *Stroke Velocity in Two Mallet Performance*. DMA Diss, The Graduate School, The University of North Carolina at Greensboro, Ann Arbor: Proquest LLC., 2008.

- Hill, Heather L. "Acoustics of Marimba Bars." Senior Thesis, Itaca College, May 2013.
- Holland, James. *Practical Percussion*. Lanham, Maryland: Scarecrow Press, 2005.
- Kite, Rebecca. "Choosing Marimba Mallets." *Percussive Notes*, April 2000: 46-49.
 —. *Keiko Abe -- A Virtuosoic Life: Her Musical Career and the Evolution of the Concert Marimba*. Leesburg, Virginia: Gp Percussion, 2007.
- Kite, Rebecca. "Keiko Abe's Quest: Developing the Five-Octave Marimba." *Percussive Notes* 36, no. 2 (April 1998): 52-54.
- MacCallum, Frank K. *The Book of Marimba*. New York: Carlton Press, 1969.
- Mackey, Steven. *See Ya Thursday*. Milwaukee: Hendon Music, Inc., 1993.
- Merrill, Greg. *The Marimba: Scientific Aspects of its construction and performance*. 1996. <http://faculty.smu.edu/ttunks/projects/merrill/MarimbaH.html> (accessed March 7, 2015).
- Papador, Nicholas. "Observations and Development of Extended Interval Usage in Four-Mallet Keyboard Percussion." *Percussive Notes*, November 2010: 34.
- Paterson, Robert A. *Sounds that Resonate: Selected Developments in Western Bar Percussion During the Twentieth Century*. DMA Diss., Ithaca: Cornell University, 2004.
- Paterson, Robert. *Introduction to my Six-Mallet Technique*. 2015. <http://robertpaterson.com/introduction-to-my-six-mallet-technique/> (accessed March 6, 2015).
- Pimentel, Linda. "The Aristocracy of Manufactured Marimbas." *Percussive Notes* 21, no. 1 (1982): 63.
- Schutz, Michael, and Fiona Manning. "Looking Beyond the Score: The Musical Role of Percussionists' Ancillary Gestures." *Society for Music Theory* 18, no. 1 (April 2012).
- Solomon, Samuel Z. *How to Write for Percussion*. New York: SZSolomon, 2002.
- Spencer, Julie. "The Horizontal Concept of Marimba Technique." *Percussive Notes* 26, no. 1 (1987): 38.
- Stevens, Leigh Howard. *Method of Movement for Marimba*. 5th Edition. Ashbury Park, NJ: Keyboard Percussion Publications, 2000.

The Deagan Resource. *Marimbas*. <http://www.deaganresource.com/marimbas.html> (accessed February 23, 2015).

Vela, David. *Information on the Marimba*. Edited by Vida Chenowith. Auckland: Institute Press, 1972.

Vienna Symphonic Library. *Marimba*. 2015. <https://www.vsl.co.at/en/Marimba/> (accessed March 6, 2015).

Wilson, Christopher. "Use and Selection of Graduated Mallets." *Percussive Notes*, Jan 2011: 38.

Zator, Brian. "Yasuo Sueyoshi's "Mirage pour Marimba"." *Percussive Notes* 38, no. 2 (2000): 53.

Zeltsman, Nancy. *Four-Mallet Marimba Playing*. Milwaukee, WI: Hal Leonard, 2003.

—. *Memo to Composers*. 2015. <http://www.nancyzeltsman.com/memo-to-composers.html> (accessed January 28, 2015).

APPENDIX A
MARIMBA DIAGRAM

This marimba diagram is taken from page 20 of the Yamaha YM-5104A/5100A/4900A/4600A owner's manual. It shows the basic design of a Yamaha 5100A marimba. The website URL is shown below.

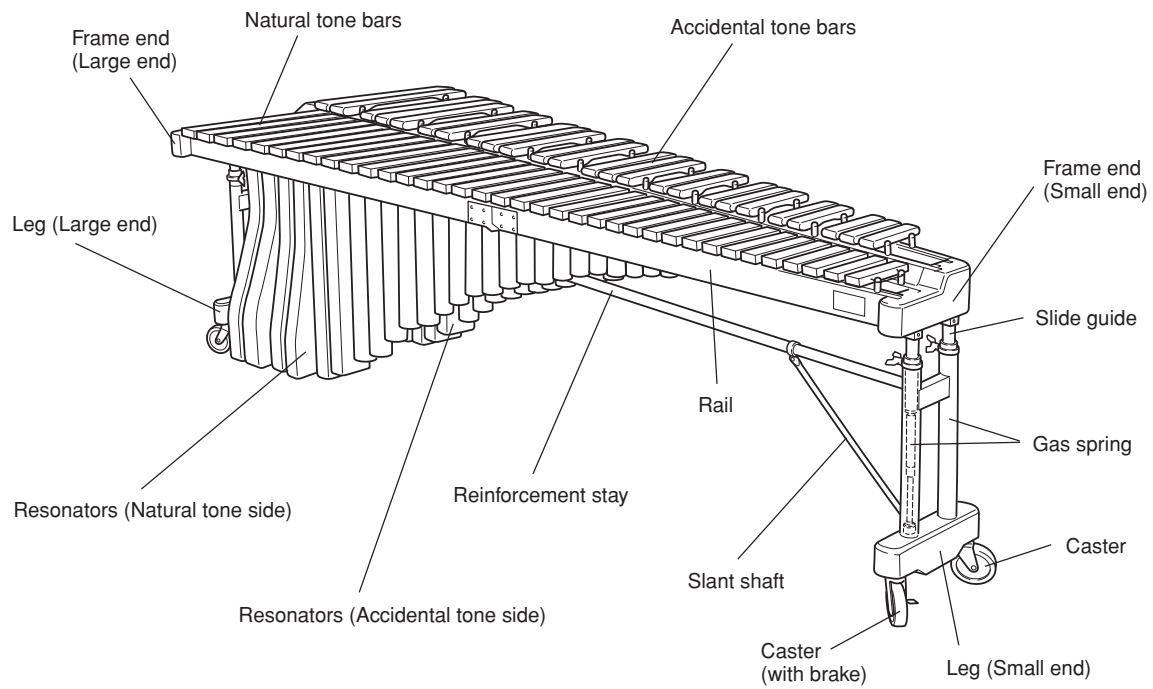

http://download.yamaha.com/api/asset/file/?language=en&site=usa.yamaha.com&asset_id=63733

APPENDIX B
ACCOMPANYING WEBSITE

The accompanying website contains audio and video examples relevant to the material. It can be accessed at the following address:

<https://sites.google.com/a/asu.edu/composing-for-marimba-tools-and-techniques-for-composers/>

APPENDIX C

MAJOR MANUFACTURER CHARACTERISTICS

Manufacturer Characteristics

While all marimba manufacturers have the basic components of the frame as well as the bars and resonators, there are many differences to note. The following table lists the characteristics the major marimba manufacturers.

Manufacturer	Resonators	Frame types*	Bar width	Tonal Qualities
Adams (Netherlands)	Aluminum, Box	Mixed	Medium	More overtones, less fundamental
Bergeruault (France)	Tubular, Tunable	Mixed	Wide	Lots of fundamental, less overtones
Coe (USA)	Brass, Tubular, Tunable	All Wood, Mixed	Wide	Lots of fundamental, less overtones
Demorrow (USA)	Brass Tubular, Tunable	All wood, Mixed	Wide (low end), Narrow (high end)	Lots of fundamental, less overtones
Kolberg (Germany)	Brass Tubular, Tunable	Mixed	Wide	Lots of fundamental, less overtones
Malletch (USA)	Brass, Tubular, Tunable	Mixed	Wide	Lots of fundamental, less harmonic content
Majestic (Netherlands)	Aluminum, Tubular	Mixed	Medium	Lots of fundamental, less overtones
Marimba One (USA)	Oval, Aluminum	All wood, Mixed	Medium	More overtones, less fundamental
Musser (USA)	Aluminum, Tubular	Mixed, Paneled Frame ends	Small	Clear pitch, less resonant
Vancore (Netherlands)	Aluminum, Box	Mixed	Medium	Clear pitch, less resonant
Yamaha (Japan)	Aluminum, Box, Tubular (6000/6100)	Mixed	Medium, Wide (6000/6100)	More overtones, less fundamental, More Fundamental (6000/6100)

*Mix refers to a mix of wood and metal frame in which the metal provides the structural integrity while the wood is for mounting the bars and aesthetics purposes.

APPENDIX D
COPYRIGHT PERMISSIONS



Joseph Millea <jmillea@asu.edu>

Apo to Kolpo Kassandra

David Kosviner <d@vidkosvi.net>
To: Joseph Millea <jmillea@asu.edu>

Wed, Mar 18, 2015 at 5:51 AM

Dear Joe,

Good to hear from you! I'm well, thanks, and I hope you are well too. Many thanks for the good news about the performances. Yes, it is going to be the premiere.

Of course you may use excerpts of the piece in your thesis and I'll be glad to answer any questions it's also great to hear that other performances are lined up – we all know that premieres are easy to get, it's the second and third performances that are difficult...AND a recording would also be wonderful!

Thanks for keeping me informed and toi, toi, toi for April 13th.

All the best,

David

From: Joseph Millea
Sent: Tuesday, March 17, 2015 7:53 PM
To: David Kosviner
Subject: Apo to Kolpo Kassandra

[Quoted text hidden]

Music Sales West
G. Schirmer, Inc.
1247 Sixth Street
Santa Monica, CA 90401
United States of America
Telephone: +1 310.393.9900
Fax: +1 310.393.9925
Email: info@musicsales.com
www.musicsales.com
www.musicsalesfilmtv.us
www.schirmer.com

Music Sales New York
G. Schirmer New York
Music Sales West Los Angeles
Music Sales London
Chester Music London
Novello & Co London
Campbell Connelly & Co London
Première Music Paris
Edition Wilhelm Hansen Copenhagen
Edition Wilhelm Hansen Helsinki
Bosworth Music Berlin
Unión Musical Ediciones Madrid
KK Music Sales Tokyo
Music Sales / Larrikin Sydney

The Music Sales Group 

April 16, 2015

Joseph Millea
802 N Laveen Dr.
Chandler, AZ 85226

RE: MARIMBA CONCERTO, by Richard Rodney Bennett
AFTER SYRINX II, by Richard Rodney Bennett
MERLIN, by Andrew Thomas

Dear Joseph,

This letter is to confirm our agreement for the nonexclusive right to reprint measures from the composition(s) referenced above for inclusion in your thesis/dissertation, subject to the following conditions:

1. The following copyright credit is to appear on each copy made:
2. Copies are for your personal use only in connection with your thesis/dissertation, and may not be sold or further duplicated without our written consent. This in no way is meant to prevent your depositing three copies in an interlibrary system, such as the microfilm collection of the university you attend, with University Microfilms, Inc or ProQuest.
3. Permission is granted to University Microfilms, Inc. and ProQuest to make single copies of your thesis/dissertation, upon demand.
4. A one-time non-refundable permission fee of seventy-five (\$75.00) dollars, to be paid by you within thirty (30) days from the date of this letter.
5. If your thesis/dissertation is accepted for commercial publication, further written permission must be sought.

Sincerely,

Music Sales West
G. Schirmer, Inc.
1247 Sixth Street
Santa Monica, CA 90401
United States of America
Telephone: +1 310.393.9900
Fax: +1 310.393.9925
Email: info@musicsales.com
www.musicsales.com
www.musicsalesfilmtv.us
www.schirmer.com

Music Sales New York
G. Schirmer New York
Music Sales West Los Angeles
Music Sales London
Chester Music London
Novello & Co London
Campbell Connelly & Co London
Première Music Paris
Edition Wilhelm Hansen Copenhagen
Edition Wilhelm Hansen Helsinki
Bosworth Music Berlin
Unión Musical Ediciones Madrid
KK Music Sales Tokyo
Music Sales / Larrikin Sydney

The Music Sales Group 

Duron Bentley
Print Licensing Manager

Schedule A

MERLIN

Music by Andrew Thomas

Copyright © 1985 by Associated Music Publishers, Inc. (BMI)

International Copyright Secured. All Rights Reserved.

Used by Permission

Warning: Unauthorized reproduction of this publication is prohibited by Federal Law and is subject to criminal prosecution.

- Movement 2, measures: 1-4, 205-207

Marimba Concerto

Music by Richard Rodney Bennett

© Copyright 1988 Novello & Company Limited.

All Rights Reserved. International Copyright Secured.

Reprinted by permission

- Measures: 21-23, 164 (cadenza)

After Syrinx II

Music by Richard Rodney Bennett

© Copyright 1984 Novello & Co Limited.

All Rights Reserved. International Copyright Secured.

Reprinted by permission

- Measures: 1



Joseph Millea <jmillea@asu.edu>

Re: [PM Europe - printed music distribution] Customer message from contact form

Percussion Music Europe <sales@pmeurope.com>
To: jmillea@asu.edu

Wed, Mar 11, 2015 at 12:55 AM

Dear Mr. Millea,

No problem to publish these excerpts, permission granted.

Best regards
Gerrit Nulens

Op 10-mrt.-2015, om 16:18 heeft jmillea@asu.edu het volgende geschreven:

<logo_mail.jpg>

Message from a PM Europe - printed music distribution customer

Customer e-mail address: jmillea@asu.edu

Customer message: Hello,
I am writing to request permission to publish an excerpt of Peter Klatzow's "Dances of Earth and Fire" in my Doctoral Thesis entitled, "Composing for Marimba: Tools and Techniques for composers." The measures I would like to use are mm. 38-42 showing the use of a grand staff in marimba composition, mm. 68-73 showing the use of multiple manuals simultaneously, and mm. 53-54 showing the notation for dead strokes.

Sincerely,
Joe Millea
jmillea@asu.edu
+1 763 607 7880
www.joemillea.com

PM Europe - printed music distribution powered by PrestiaShop™

Percussion Music Europe bvba
PM Europe
Langveld 6 / 3300 Tienen / Belgium
t: +32 16 883754 / f: +32 16 701663
btw/vat/tva: BE0446046382
www.pmeurope.com
sales@pmeurope.com



Joseph Millea <jmillea@asu.edu>

Print License request

C. Alan Publications [Licensing] <licensing@c-alanpublications.com>
To: Joseph Millea <jmillea@asu.edu>

Tue, Mar 24, 2015 at 3:58 AM

We, C. Alan Publications, hereby give permission to Joseph Millea to reprint the excerpt from measure 230 to 232 (Player 2) from Philip Carlsen's "Evening's Sabres" in his doctoral thesis, "Composing for Marimba: Tools and Techniques for Composers" at Arizona State University. Any questions may be addressed to me using the contact information below.

Sincerely,

Nathan Daughtrey
Product Development & Composer Relations
C. Alan Publications

nathan@c-alanpublications.com
(336) 272-3920



Joseph Millea <jmillea@asu.edu>

Doctoral Thesis publication permission

Bobo, Kevin Andrew <kbobo@indiana.edu>
To: Joseph Millea <jmillea@asu.edu>

Thu, Mar 19, 2015 at 7:59 AM

Joseph,

Yes, you have my permission to use mm. 159-161 of "Ezekiel's Wheel" in your doctoral thesis. thank you

Kevin Bobo

From: Joseph Millea <jmillea@asu.edu>
Date: Wednesday, March 18, 2015 at 10:19 AM
To: MUSTECH <kbobo@indiana.edu>
Subject: Doctoral Thesis publication permission
[Quoted text hidden]

3/18/2015

Arizona State University Mail - from Keiko Abe



Joseph Millea <jmillea@asu.edu>

from Keiko Abe

Motoko Kobayashi <motokosari@be.to>
To: jmillea@asu.edu

Wed, Mar 18, 2015 at 1:37 AM

Dear Joe,

Keiko is glad that you are writing the doctoral thesis about marimba.
Keiko allows you to use mm. 16-18 for Galilee Impressions.

Keiko is now composing a piece entitled "Marimba Concertino Wind Across Mountains ~for Solo Marimba and Strings Orchestra~. This is a rental piece.
Its piano reduction will be published soon and Keiko hopes you to play this piece with six mallets.

Keiko sends her warm regards.

Motoko

3/10/2015

Arizona State University Mail - Permission to reprint excerpt in doctoral thesis



Joseph Millea <jmillea@asu.edu>

Permission to reprint excerpt in doctoral thesis

vinao <alejandrovinao.com>
To: Joseph Millea <jmillea@asu.edu>

Tue, Mar 10, 2015 at 5:46 AM

[Quoted text hidden]

> www.joemillea.com <<http://www.joemillea.com>>

Dear Joe,

You are very welcome to use the excerpt in your Doctoral Thesis.

However, if the thesis were to be published the permission would not apply and you would have to contact me again.

All the best,

Alejandro
<http://www.vinao.com>



Joseph Millea <jmillea@asu.edu>

Akiho Doctoral Thesis Permission

Dacey Bell <daceybell@gmail.com>
 To: Joseph Millea <jmillea@asu.edu>

Tue, Mar 24, 2015 at 8:55 PM

Hi Joe,

You have permission to use these excerpts in your thesis.

I have attached digital copies of the excerpts to this email. They are in a variety of different file formats so you are free to choose whichever file format works best with your software. I prefer the .eps files. This file type allows for better resizing of the image since it is a vector drawing. The other files should work well too.

Please let me know if you have any other questions or if I can assist in anyway.

Best,

Dacey Bell
 Publishing Manager
 Aki Rhythm Press

From: Joseph Millea <jmillea@asu.edu>
Date: Tuesday, March 24, 2015 at 11:24 AM
To: Dacey Bell <daceybell@gmail.com>
Subject: Akiho Doctoral Thesis Permission

[Quoted text hidden]

15 attachments

- ▲ = top of resonator
 (gap between accidentals) **AKIHO - Ligneous (m.27 - Description 1b).jpg**
 61K
- ▲ = top of resonator
 (gap between accidentals) **AKIHO - Ligneous (m.27 - Description 1c).png**
 42K
- ▲ = top of resonator
 (gap between accidentals) **AKIHO - Ligneous (m.27 - Description 1d).tif**
 87K



Joseph Millea <jmillea@asu.edu>

Doctoral Thesis publishing request

Info <info@libbylarsen.com>
To: Joseph Millea <jmillea@asu.edu>

Tue, Mar 17, 2015 at 1:41 PM

Hi Joe,

Yes, certainly, I'd be happy for you to include the use mm. 54-56 from *Like Blind Men Tapping in the Dark*. Let me know if I can help you further.

Best,

Libby Larsen



From: Joseph Millea [mailto:jmillea@asu.edu]
Sent: Tuesday, March 17, 2015 1:22 PM
To: info@libbylarsen.com
Subject: Doctoral Thesis publishing request

[Quoted text hidden]



Joseph Millea <jmillea@asu.edu>

Permission to reprint

Steven Snowden <stevensnowden@gmail.com>
To: Joseph Millea <jmillea@asu.edu>

Tue, Mar 10, 2015 at 8:59 AM

Hi Joe,

Thanks for asking. You have my permission to reprint excerpts from *Long Distance* in your thesis.

Also, thanks for letting me know about the performance. Could send me a pdf or picture of the program when you have it? (even a cell phone pic will work) I'll need it for ASCAP performance notifications.

Best of luck on your recital and thesis!

Best,
Steve

Steven Snowden
www.stevensnowden.com

co-director
[Fast >>Forward >>Austin](#)
new music organization

[Quoted text hidden]



March 12, 2015

Mr. Joe Millea
ASU School of Music, Room E-185
50 E. Gammage Parkway
Tempe, AZ 85287-0405

Re: Dissertation Permission

Dear Joe:

Carl Fischer, LLC on behalf of Theodore Presser Company, authorized agent for copyright owner, Ongaku-No-Tomosha Corporation hereby grants to you (the "Licensee") non-exclusive permission to include excerpts from the copyrighted work entitled "Mirage Pour Marimba" (out of "Japanese Marimba Piece 1") by Yasuo Sueyoshi in your dissertation to Arizona State University. The Dissertation is to be published by Arizona State University and UMI ProQuest only, as per the following terms:

Term: Five (5) years*
Media: On-line distribution through Arizona State University and UMI ProQuest only
Fee: Twenty-Five Dollars (\$25.00)

* Note: This permission is for a term of five (5) years only and expires on March 12, 2020. In the event that you wish to renew this license upon expiration, please request the necessary permission at the time and your request will be reviewed accordingly.

The copyright notice, as it appears in the published works, shall appear in the Dissertation along with an indication that it was included with permission.

Please sign and return one copy of this agreement.

Carl Fischer, LLC
On behalf of Theodore Presser Company,
Authorized agent for copyright owner Ongaku-No-Tomosha Corporation

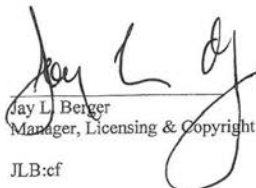
Jay L. Berger
Manager, Licensing & Copyright
JLB:cf

Joe Millea

48 Wall Street 28th floor, New York, NY 10005
P (212) 777-0900 • F (212) 477-6996 • www.carlfischer.com



March 12, 2015

Marimba Productions, Inc.
Keyboard Percussion Publications, Studio 4 Music, Resonator Records
P.O. BOX 467 ASBURY PARK, NEW JERSEY USA 07712
PHONE: 732.774.0011
Fax: 732.774.0033
mpi@mostlymarimba.com

March 12th, 2015

Permission to Publish Excerpts for Doctoral dissertation

Dear Mr. Millea,

This letter shall serve as permission for you to use excerpts from the following pieces published by Marimba Productions Inc. in your doctoral dissertation "Composing for Marimba: Tools and Techniques for Composers." Please include the corresponding copyright notice next to each example.

1. *Prelude No. 1* by Raymond Helble:

©1977 Studio 4 Music
by Marimba Productions Inc.
Used with permission.

2. *Baroque Suite* by Daniel Levitan:

©2001 Keyboard Percussion Publications
by Marimba Productions Inc.
Used with permission.

3. *Marimba Quartet* by Daniel Levitan:

©1996 Keyboard Percussion Publications
by Marimba Productions Inc.
Used with permission.

4. *Two Mexican Dances* by Gordon Stout:

©1977 Studio 4 Music
by Marimba Productions Inc.
Used with permission.

Marimba Productions, Inc.
Keyboard Percussion Publications, Studio 4 Music, Resonator Records
P.O. Box 467 ASBURY PARK, NEW JERSEY USA 07712
PHONE: 732.774.0011
Fax: 732.774.0033
mpi@mostlymarimba.com

5. *Libertango* arr. by Eric Sammut

©1975 Edizioni Curco, used with permission.
©2002 Keyboard Percussion Publications
by Marimba Productions Inc.
Used with permission.

By us granting you permission, you must agree to send us a copy of the document when complete. Please contact us if you have any questions or concerns.

Thank you.

Sincerely,

Alex Cofone



Joseph Millea <jmillea@asu.edu>

Doctoral Thesis publication request

Lowell Layne <Lowell@innovativepercussion.com>
Reply-To: Lowell@innovativepercussion.com
To: alex@innovativepercussion.com
Cc: jmillea@asu.edu

Wed, Mar 18, 2015 at 10:30 AM

Dear Joe,

Yes, you have permission from Innovative Percussion to use the illustration from Mark Ford's *Stubernic* in your doctoral thesis. We only ask that you cite the source properly. Let us know if you may need anything else. Best of luck!

Sincerely,

Lowell Layne
Director of Financial Operations
Innovative Percussion Inc.
470 Metroplex Drive, Suite 214
Nashville, TN 37211
Phone: 615.333.9388
Fax: 615.333.9354
www.innovativepercussion.com



From: Joseph Millea [<mailto:jmillea@asu.edu>]
Sent: Tuesday, March 17, 2015 2:13 PM
To: info@innovativepercussion.com
Subject: Doctoral Thesis publication request

[Quoted text hidden]



Joseph Millea <jmillea@asu.edu>

Permission to Reprint in Doctoral Thesis

orders@bachovich.com <orders@bachovich.com>
To: Joseph Millea <jmillea@asu.edu>

Tue, Mar 10, 2015 at 5:46 PM

Hello Joe:

This email will serve as evidence of written permission from Bachovich Music Publications to use an excerpt of:

"Gene Koshinski's *Variations and Vnao* in your doctoral thesis entitled "Composing for Marimba: Tools and Techniques for composers."

The excerpts you are requesting are mm. 158-159 illustrating the usage of Glissandi, and mm. 198-200 showing exemplary two mallet composing."

Best Regards,
Mariana Ramirez

Production Manager
Bachovich Music Publications
www.bachovich.com
[Quoted text hidden]



Joseph Millea <jmillea@asu.edu>

Re: [Message from the contact form]

N. J. Zivkovic - Office <office@zivkovic.de>
To: Joe Millea <jmillea@asu.edu>

Thu, Mar 19, 2015 at 6:37 PM

joe you may use those examplers for your dissertation work.
Best
NJZ

Am 17.03.2015 um 19:10 schrieb Joe Millea:

name: Joe Millea
email: jmillea@asu.edu
subject: Sheet Music / Noten & CD's
MAILING_list: NO

message: Hello, I am writing to inquire about using several examples of Mr. Zivkovic's music in my upcoming doctoral thesis entitled "Composing for Marimba: Tools and Techniques for Composers." I would like permission to use the following excerpts: - Uneven Souls, Marimba part, mm. 58-61 showing exemplary use of double vertical strokes in a thematic manner. -Il Canto dei Gondolieri, mm. 47-49, illustrating use of one handed roll, and mm. 3-4, illustrating the use of mandolin roll. Sincerely, Joe Millea jmillea@asu.edu +1 763 607 7880 www.joemillea.com -

--

Prof. Nebojsa Jovan Zivkovic
Composer & Multipercussion Concert Artist
Professor of Percussion, University Novi Sad,
Konservatorium Wien, City of Vienna University
Prv:
Meerfeldstrasse 23
68163 Mannheim, GERMANY
Phone:+49 621 8324 8084
Fax: +49 621 8324 8085

www.zivkovic.de
Tue nur das Rechte in deinen Sachen,
das Andere wird sich von selber machen.
Goethe

BIOGRAPHICAL SKETCH

Percussionist and music educator Joe Millea is currently a faculty member at Veritas Preparatory Academy in Phoenix, Arizona teaching music. He is also an instructor and arranger with the Gold Drum and Bugle Corps of San Diego, California. Prior to that he served on the faculty of National American University in Brooklyn Center, Minnesota teaching music courses. In 2013/14 Joe studied at the Royal College of Music in London, United Kingdom performing and researching the marimba. At RCM he was supported by a Leverhulme Postgraduate Studentship. Prior to his time in the U.K., Joe served on the faculty at Collins College in Phoenix, Arizona teaching courses in digital audio, music theory, music history, music business, and music composition. He was also the principal Percussionist and Timpanist with the Scottsdale Arts Orchestra in Scottsdale, AZ for three seasons, a percussion instructor/arranger with the Arizona State University Sun Devil Marching Band and Director of Instrumental Music at La Casa de Cristo Church in Scottsdale, Arizona. As a performer, Joe has performed with many ensembles throughout North America. Joe is a co-founder of the Millea/Drum Duo, a Phoenix-based marimba and percussion duo with Jordan Drum. The duo recently performed as guest artists at the 2012 Southern California Marimba Competition, 2012 National Conference on Percussion Pedagogy, and the 2012 Minnesota Percussion Association Day of Percussion. As a soloist, Joe commissions and performs new works regularly. Recently, he gave a master class and premiered Josh Hill's *Ourzazate* for Solo marimba in Adria, Italy. He has worked with many world-renowned performers, conductors and composers, including Francesco Pavan, Sir Neville Marriner, Mark Russell-Smith, Stuart Marrs, Bill Carruthers, Eugene Rousseau, Dave Karr, Michael Christie, Bob Becker, Tom Ashworth, Steven Ridley, Josh Hill, and Mary Ellen Childs. Joe received his Bachelor's degree in Music Performance and Music Education from the University of Minnesota-Twin Cities and Master's Degree in Music Performance from Arizona State University. His primary teachers are Fernando Meza, J.B. Smith, Daniella Ganeva, Peter Kogan, Earl Yowell, Mark Sunkett, Simone Mancuso, Brian Duffy, Matt Kettlehut, Dom Moio and Phil Hey.