

# Composite Flywheels For Energy Storage – Design Considerations

R.E. Hebner, J.H. Beno, J.D. Herbst<sup>1</sup>

## Introduction

Composite flywheels are designed, constructed, and used for energy storage applications, particularly those in which energy density is an important factor. Typical energies stored in a single unit range from less than a kilowatt-hour to levels approaching 150 kilowatt-hours. Thus, a single composite flywheel can be equivalent, in stored energy, from one to more than 100 automotive batteries. Moreover, in flywheel systems, the stored energy and output power are relatively independent of each other. Flywheels under design or construction or testing include those shown in Table 1. In this table, the entries are arranged in order of increasing stored energy. Note that this ordering does not correlate with ordering according to power level. In a flywheel, geometry, materials, and rotational velocity set the stored energy. The design of the output circuit defines the output power, constrained, of course, by the fact that the time for which the peak output power can be drawn is limited by the stored energy. So, one of the advantages presented by flywheel batteries is that stored energy and output power are nearly independent variables in the system design.

Table 1. Typical characteristics of specific composite flywheel designs

	Peak Power	Stored Energy	Maximum Velocity (rpm)	Rotor Mass (kg)
Satellite	2 kW	1.4 MJ 0.4 kW-hr	53,000	30
Hybrid Bus	150 kW	7 MJ 2 kW-hr	40,000	60
Space Station	3.6 kW	13 MJ 3.7 kW-hr	53,000	75
Hybrid Combat Vehicle	11 MW pulsed 350 kW continuous	25 MJ 7.3 kW-hr	18,000	280
Electro-magnetic Launcher	5-10 GW	50-150 MJ 14-42 kW-hr	10,000	4,000
Train	2 MW	480 MJ 130 kW-hr	15,000	2,500

Energy storage flywheels are generally useful in power conditioning applications, i.e., when there is a mismatch between the power generated and the power required by the load. Two examples of this mismatch are a temporal mismatch and a mismatch in magnitude. Temporal mismatches occur, for example, in power quality situations when the load needs uninterrupted power and the flywheel system is used to provide the power to ride through short interruptions, surges, or sags. They also occur in some renewable sources, such as solar or wind power, in which the temporal variation of the source is frequently lightly correlated or uncorrelated with any temporal variations of the load. A mismatch in power amplitude can occur when the load requires more power, for a short time, than the source can produce. The use of a flywheel in a hybrid vehicle, for example, permits the engine to be designed to provide only the power needed to overcome losses and not have the inefficiencies produced when the engine must also provide power for maximum acceleration.

---

<sup>1</sup>University of Texas at Austin, Austin, Texas. Email: [r.hebner@mail.utexas.edu](mailto:r.hebner@mail.utexas.edu)

The authors acknowledge that the information presented has been developed under projects funded by NASA, the Federal Railroad Administration, the National Institute of Standards and Technology, and the Department of Defense and thank these organizations for their support. These are not the results of any single project. Rather they are considerations that have been extracted as common among a range of applications.

The low end of the energy range is set by economics. Today, the cost of a composite flywheel system does not scale in proportion to the benefits for lower energy systems. The high-energy end is being pushed upward, but technical challenges are significant.

### **Material Strength Considerations**

Material strength is a significant design constraint across this energy range. For example, modern wheels require the strength of composite materials. Because of this strength, composite wheels can be spun faster than metallic flywheels and exploit the quadratic dependence on angular velocity to store energy in a smaller, lighter wheel. Existing composite systems limit the wheel tip speed to about 1 km/s. Research is continuing to develop higher strength materials, improved manufacturing techniques to maintain material strength through fabrication, test techniques for manufacturing quality control, and improved methods of nondestructive evaluation of cured composites. With the improvements in materials tip speeds of 1.5 km/s appear to be possible if manufacturing issues can be kept in control.

To facilitate the design of high strength structures, the University of Texas at Austin has developed and uses a software package for rapid prototyping of filament-wound composite structures. For complex structures, the code optimizes tow placement for a geodesic wind. It accounts for the effects of tow friction and bridging to predict the actual tow location. The tow positional information can be downloaded into a finite element analysis code to predict the mechanical properties of the completed object. When the desired mechanical properties are achieved, the winding pattern is downloaded to the winding machine to construct the structure. In the preliminary tests that have been completed, the predicted and as-constructed materials properties are within a few percent of each other.

This degree of predictability requires control of materials and manufacturing processes. Targeted diagnostic tests are being developed and used to assure that the highest strength structures are being designed and constructed. The primary quality control system used today at the University of Texas is hydroburst testing [1]. The basic concept of hydroburst testing is to enclose a fluid inside a ring of the composite material under test and to pressurize the fluid until the composite ring bursts. When the manufacturing process is under control, the standard deviation of a number of samples is typically less than 5%. This variation is due both to any variation in the material and in the test procedure. Low strength and/or high standard deviations would suggest that there is a problem in either the incoming material or in the manufacturing procedure. Recent evaluations have shown that this approach is an excellent tool to evaluate the success of transferring flywheel-manufacturing technology from one composite manufacturing site to another. Such documented transfer capability is needed if the technology is to achieve widespread use.

A nondestructive approach to strength characterization that is current under development is prompt-gamma neutron activation analysis. The approach uses low energy neutrons (commonly called “cold neutrons”) to interact with the nuclei of the materials that constitute the composite. Higher energy neutrons would have too little interaction with the composite material to produce measurable signals in a reasonable time. Because of the low cross-section for interactions, neutrons penetrate the composite. The neutrons that are absorbed excite the nuclei which decay, emitting a photon of gamma radiation. By measuring the photon energy, the atom that contained the excited nucleus can be identified. This process permits the identification of the atomic constituents of the material but is not likely to damage to the strength of the material. The reason for the limited damage is that material strength is determined by the chemical bonds between the various atoms. The wavelengths of both the neutrons and the photons are too short to affect these bonds. They interact primarily with the nucleus. Further, the nuclear interaction is simply a temporary excitation and subsequent decay back to the normal state.

The prompt-gamma neutron activation analysis has detected water variations in cured composites, has detected variations in elemental composition among different samples, and shows promise of detecting local variations in fiber density. Figure 1 shows data from the measurements of absorbed water compared to measurements of the mass change. Measurement of mass change is the conventional approach to determining water content in composites [2].

Water content is of interest as conventional techniques of nondestructive evaluation of composite materials are based on acoustic probing in a water bath. Water has long been recognized, however, as a factor in reducing the tensile strength of composites [3]. Recent data on the types of hydrogen bonds formed by the water molecules and how these bonds affect the degree of crosslinking [4] reinforce the concern over water, particularly in flywheel applications in which it is important to maintain as much material strength as possible.

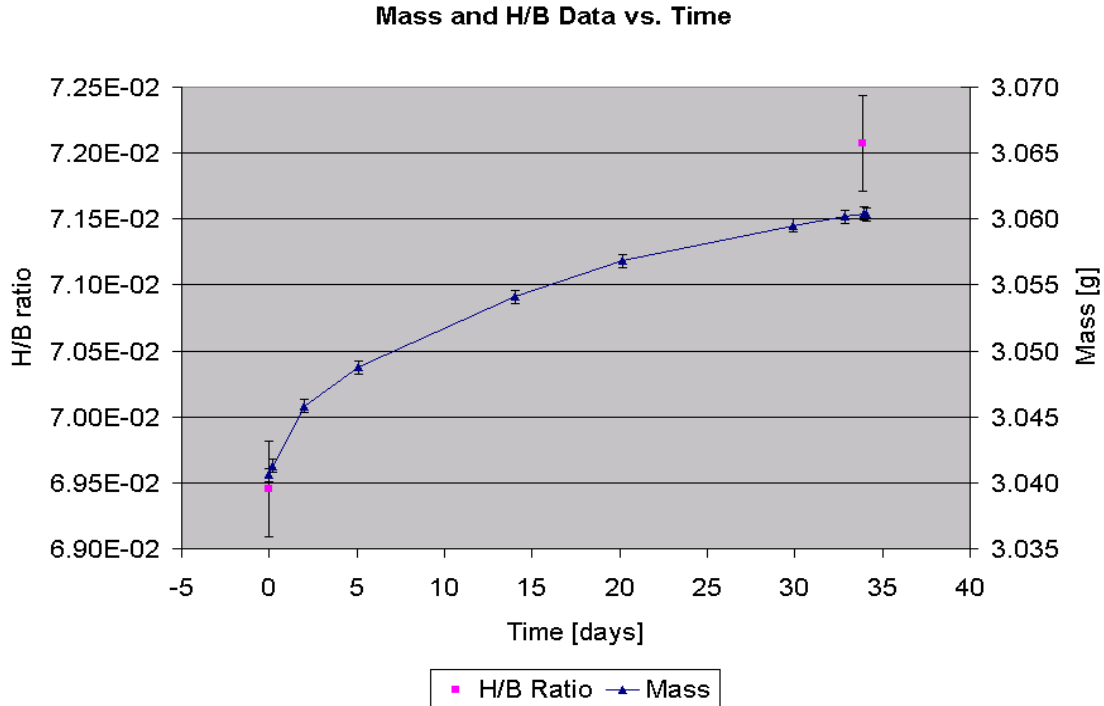

Figure 1. Measurement of the water content in a cured epoxy soaked in a water bath. The H/B ratio is the ratio of hydrogen to boron in the sample. The boron content is constant and measurement of this ratio permits measurement of the change in hydrogen, i.e. water uptake, even though the neutron fluence from the reactor is not constant.

### Rotor Dynamics

Management of rotor dynamics is critical to the safe operation of high energy density flywheels. An example of a large flywheel (i.e., a wheel with high energy density) is one being developed for the Advanced Locomotive Propulsion System (ALPS). This is an ongoing project to demonstrate a hybrid propulsion system in a high-speed passenger locomotive. The propulsion system uses a gas turbine prime mover directly driving a high-speed synchronous generator to supply the steady-state power demands of the locomotive. For acceleration and speed maintenance on grades, prime power is supplemented with up to 2 MW of additional power from a 480 MJ, 15,000 rpm energy storage flywheel. The flywheel also allows recovery of braking energy and load leveling of the gas turbine, reducing thermal cycling and greatly extending turbine maintenance intervals. Figure 2 is a cross section of the ALPS flywheel showing the major components.

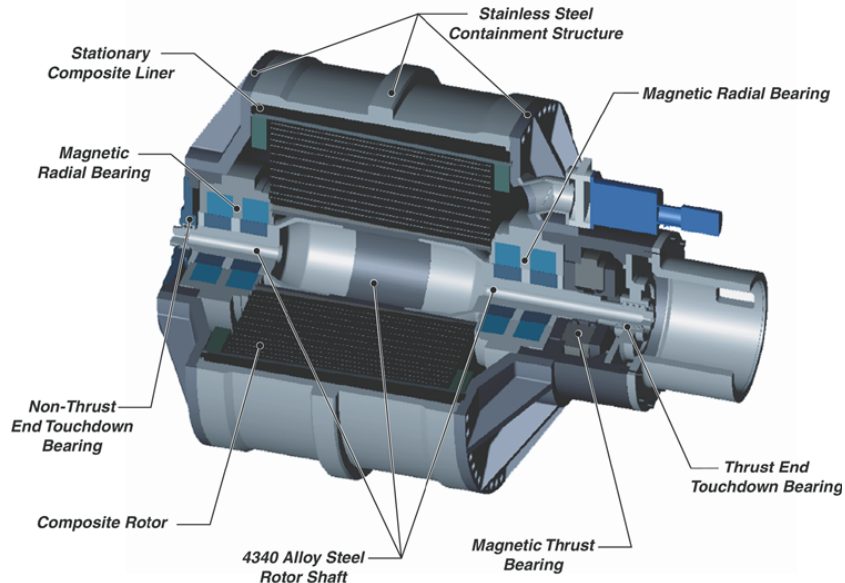

Figure 2. Cross-section view of ALPS flywheel.

TXROTOR is a finite-element-based rotor-dynamics code developed at the University of Texas at Austin. To provide a well-engineered system, TXROTOR is used to define the natural frequency map for each specific flywheel design. Typically, the operating speed of the flywheel ranges between 50% and 100% of maximum speed (absorbing and delivering 75% of the stored energy). These speeds determine two sides of the normal operating region as indicated in Figure 3, which shows the operating range and relevant rotor modes for the ALPS flywheel.

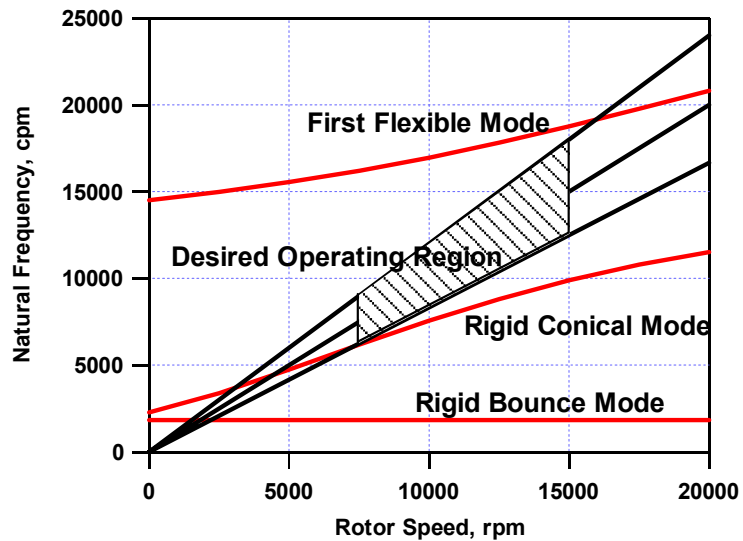

Figure 3. Natural frequency map of the ALPS flywheel rotor

Figure 3 is a hybrid design tool useful in describing an operating region for a flywheel. The basis for the figure is a graph of the natural frequency of the rotor modes as a function of the rotational velocity of the rotor. Superimposed on the graph are three lines; the center one shows that the actual rotor speed is the same as the anticipated rotor speed.

The design goal is to maintain at least a 20% margin between the operating speed and any rotor-critical frequency throughout the normal operating speed range. The operating speed range is thus defined by the minimum and maximum speeds and two lines corresponding to frequencies 20% above and 20% below the operating frequency. These margins define the other two sides of the target operating range represented by the shaded region in Figure 3. This type of analysis shows that 75% of the energy can be extracted without encountering any of the natural modes of the rotor. If the analysis showed an overlap with the rotor modes, it would be necessary to modify the size, shape, or materials to shift the natural frequencies out of the operating range. Obviously, the bearing system can handle occasional excursions through the natural modes of the rotor, but by keeping them outside of the normal operating range, reliability is enhanced.

Flywheels typically operate above the first two rigid body vibration modes and below the first bending critical frequency. Maintenance of adequate margins between the operating speed of the rotor and first flexible mode critical frequency is crucial to safe, stable operation of the magnetic bearings. Although it is not usually as significant an issue, it is also true that the magnetic bearings can couple the natural modes of the containment structure to the rotor.

An unresolved rotordynamic issue receiving significant analytical and experimental attention involves the flywheel rotordynamic behavior while operating on backup or touchdown bearings. Touchdown bearings are incorporated into active magnetic bearing systems to allow safe shutdown of the flywheel in the event of a magnetic bearing failure or loss of control system stability. One critical phenomenon involves excitation of a reverse whirl mode due to friction in the touchdown bearing system or unintended contact between the rotor and stator. Some analytical work [5] suggests that the reverse whirl frequency can be limited by compliant mounting of the flywheel stator structure, but recent experimental work [6] indicates that the reverse whirl frequency can continue to accelerate to frequencies many times higher than the rotational speed of the rotor (depending on the ratio of the rotor diameter to the clearance). Reverse whirl is the name given to the precession of the rotational axis of the rotor in the opposite direction as the rotor rotation.

The limited understanding of the factors influencing this process in large systems makes it extremely difficult to predict the lateral and torsional forces associated with reverse whirl and the final distribution of the stored energy of the flywheel. While not typically a safety issue in conventional low-inertia turbomachinery, the stored energy in high-inertia flywheel rotors can lead to extremely high forces and extensive damage to hardware. Until this is resolved, there continues to be the likelihood that containment vessels will be over-designed, adding needless additional cost.

### **Thermal Management**

Another important issue for high-speed flywheel rotors supported on magnetic bearings is thermal management. The non-contacting nature of the magnetic bearings limits heat rejection from the rotor to radiation heat transfer. Two primary sources of heat are found in all magnetically levitated rotors independent of motor/generator configuration: electromagnetic losses in the bearings and windage losses on the rotating surfaces of the flywheel rotor. For partially and fully integrated flywheel designs (i.e., designs for which the motor/generator is on the same shaft and in the same enclosure as the flywheel), additional thermal losses are generated by the motor/generator.

Electromagnetic losses in the rotating components of the flywheel bearing system and motor/generator are minimized by the use of laminated structures. As flywheel speeds and sizes have increased to take advantage of higher performance composite materials, the structural requirements on the laminated components have increased beyond the capability (mechanical strength or available sizes) of conventional electrical steels. Although some higher strength materials are available in thin sheets suitable for laminations, their magnetic performance, especially at the high electrical frequencies required by flywheel applications, is not well characterized. Calculation of eddy current and hysteresis losses in the laminations is further complicated by the complex magnetic field distribution in the magnetic bearings.

The second source of heating on the flywheel rotor is windage friction on the rotating surfaces. Most high-speed rotors are operated in a vacuum environment to minimize these losses, but windage heating cannot be completely avoided. Although there is good understanding, both analytical and experimental, for windage

losses at higher pressures, the phenomenon is not as well characterized at the pressures and surface velocities seen in current flywheel systems. This can be seen in the excellent agreement between losses and heating predicted by the Navier-Stokes equations and experimental data on flywheel rotor heating during loss of vacuum events [7].

As rotational speeds increase, however, tip speeds increase and the pressure must be further reduced to keep temperature rises to an acceptable level. For a composite rotor, the upper operating temperature is typically bounded by the necessity to stay well below the first glass transition temperature of the epoxy. The approach used generally to date has been to over-design the vacuum system to assure minimal losses. As these devices are used more widely, it becomes increasingly important to predict the rotor temperature as a function of pressure. Good models have not yet been demonstrated for the region in which the residual gas begins to stop behaving as a classical fluid (i.e., outside of the region described by the Navier-Stokes equation). Additional analytical and experimental work is needed to further characterize windage heating and thermal management at pressures outside of the Navier-Stokes regime.

Finally, it should be noted that it is challenging, but not impossible, to provide some active cooling to a levitated high-speed rotor. As these techniques are refined, it will be important to be able to model the rotor temperature to support engineering trade studies between control of pressure in the containment vessel and control of the coolant.

## Conclusions

Composite flywheel design has reached a level of maturity sufficient to assure that robust systems with a wide range of operating parameters can be designed and built with confidence. Additional research and development is necessary to move to higher speeds, higher temperatures, higher energy density, or new materials.

## References

- [1] Thompson, R.C., Pak, T.T., Rech, B.M, "Hydroburst Test Methodology for Evaluation of Composite Structures," *Proc. 14<sup>th</sup> ASTM Symposium on Composite Materials: Testing and Design*, March 2002, in press.
- [2] ASTM D 5229/D 5229M, "Standard Test Method for Moisture Absorption Properties and Equilibrium Conditioning in Polymer Matrix Composite Materials," American Society for Testing and Materials, West Conshohocken, PA., USA, 2000.
- [3] C-H. Shen and G. S. Springer, "Effects of Moisture and Temperature on the Tensile Strength of Composite Materials," *Environmental Effects on Composite Materials*, Vol. 1., Technomic Publishing, Westport, CT, G. S. Springer, ed., pp. 79 – 92, 1981.
- [4] A. Tcharkhtchi, P. Y. Bronnec, and J. Verdu, "Water absorption characteristics of diglycidylether of butane diol– 3,5-diethyl-2,4-diaminotoluene networks," *Polymer*, Vol. 41, pp. 5777-5785, 2000.
- [5] H.F. Black, "Interaction of a Whirling Rotor with a Vibrating Stator Across a Clearance Annulus," *Journal of Mechanical Engineering Science*, Vol.10, No. 1, 1968.
- [6] A.R. Bartha., "Dry Friction Backward Whirl of Rotors," Doctoral Dissertation to Swiss Federal Institute of Technology, Zurich, 2000.
- [7] R. Thompson, J. Kramer, and R. Hayes, "Response of an Urban Bus Flywheel Battery to a Rapid Loss-of-Vacuum Event," 2002 SAE World Congress, March 2002, in press.