

PSE
ARCHERY

COMPOUND BOW USER'S GUIDE

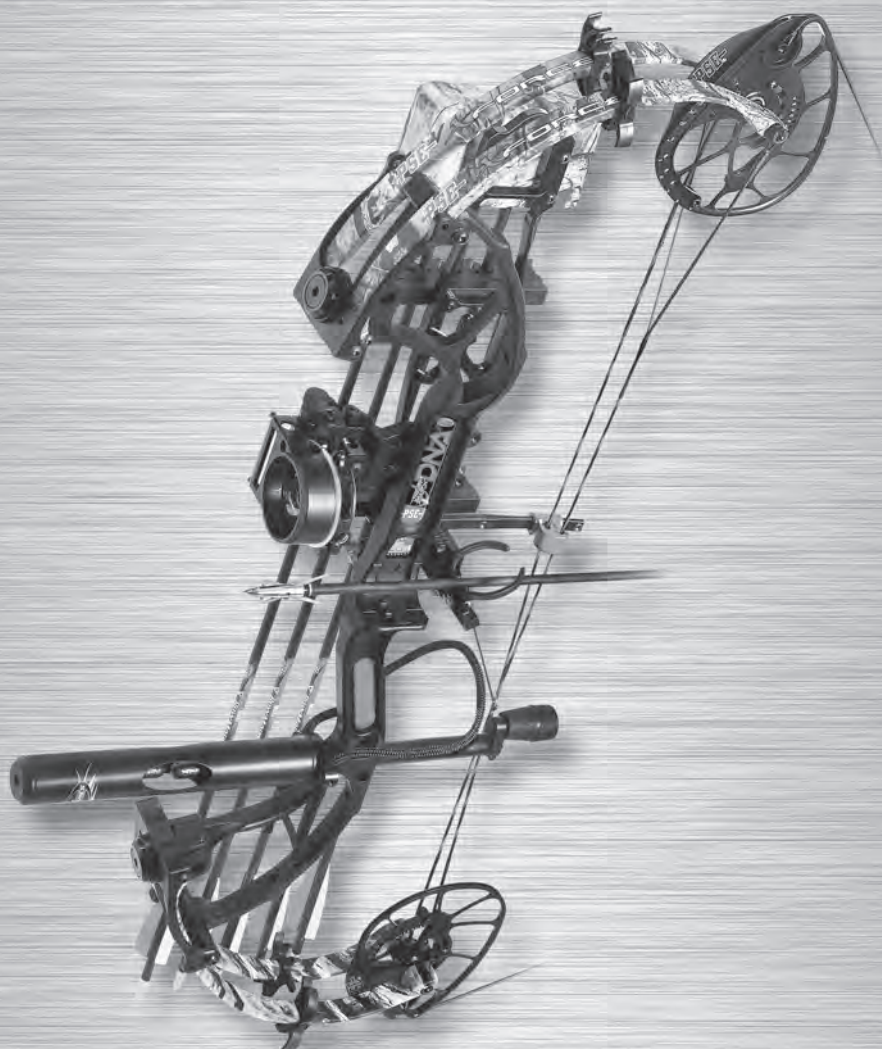

PRECISION SHOOTING EQUIPMENT, INC.



Thank you from the entire PSE family for purchasing a PSE bow! Your bow was manufactured from the finest materials available and handcrafted with pride in the USA. With proper care you will enjoy the use of this product for years to come.

Please read this entire booklet before shooting or adjusting your bow. Remember, many adjustments to a compound bow require the use of a bow press. Whenever shooting a bow, be certain of your target as well as what else lies down range.

NOTE: IMPORTANT WARRANTY REGISTRATION INFORMATION IS ON PAGE 22

GENERAL OPERATING INSTRUCTIONS

- Always inspect your bow thoroughly before each shooting session to insure that it is in good working order. Check for worn, loose or missing components and have them replaced at an authorized PSE dealer as required, i.e. bushings, spacers, etc.
- Inspect your arrows to insure that they are straight, undamaged and that each nock is in good condition. A cracked nock can break when fired from the bow and cause the bow to "dry fire" resulting in possible injury to the archer and damage to the bow. Dry-firing is drawing and releasing the bowstring without an arrow on the string.
- When purchasing arrows for your bow, consult the selection chart from the arrow manufacturer and select the correct arrow for your application. Always use an arrow that is at least 5 grains per pound of peak bow weight. Failure to do so could cause personal injury and damage to your bow.

BOW MAINTENANCE

Your PSE bow will give you many years of use if maintained and cared for properly.



IMPORTANT: Before servicing any PSE bow in a bow press, back out each limb bolt to the minimum draw weight as indicated on your bow hang tag.

- Keep synthetic cables and strings waxed. Apply bow string wax to your synthetic cables and string before each shooting session.
- Strings and cables must be replaced periodically. A worn cable or string can suddenly break causing serious injury to the archer and damage to the bow. It is recommended that the string and cables be replaced at least every 5,000 shots or 12 months. **PSE recommends that this work be performed by an authorized PSE dealer.**
- Always store your bow in a cool dry place. High temperatures, such as those that can occur in the interior of a vehicle, can cause serious damage to your bow.
- After use in high humidity or damp conditions, wipe metal components of bow with a light oil.



SAFETY

As with any weapon, safe operation of your PSE bow must always be the highest priority.

ALWAYS WEAR SAFETY GLASSES WHEN HANDLING A BOW.

Do not attempt to use your bow without proper instruction. Doing so can result in serious injury.

- NEVER DRY-FIRE ANY BOW.** Dry-firing is drawing and releasing the bowstring without an arrow on the string. Dry-firing will likely cause damage to the bow and serious injury to the archer. In the event of a dry-fire, have an authorized PSE dealer inspect the bow for damage. **DO NOT DRY-FIRE THE BOW MULTIPLE TIMES!**
- Always be sure of your intended target as well as what lies behind the target area. An arrow can travel a considerable distance, so it is important to have a safe and sound backstop.
- If you draw a bow and need to let it down, do so in a slow and careful manner. Keep your support arm straight and prepare for a rapid and violent let-down. Avoid hitting your hand on protruding accessories such as the cable guard or quiver. Keep your head and face back and out of danger during let-down. Never draw a bow with a peak weight above your comfort level. Always use a bow sling when drawing a bow.
- Never modify any part of the bow or its components by drilling extra holes or removing material. This voids the warranty and presents safety problems.
- It is not recommended to time the bow using a draw board unless the draw board is operated by a winch or other mechanical pulling device.



COMPOUND BOW TERMINOLOGY

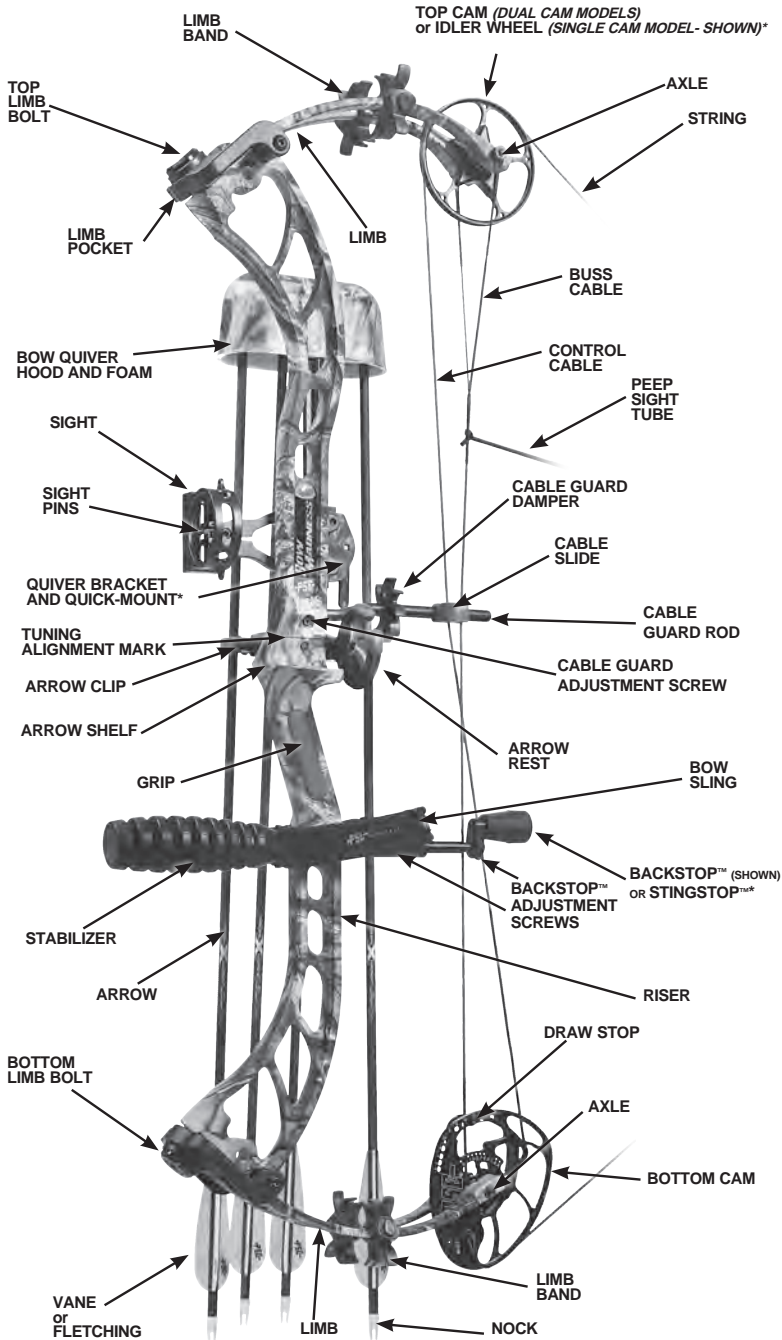

* = DEPENDS ON BOW MODEL

SETTING-UP YOUR BOW

NOCKING POINT PLACEMENT:

Finger shooters: Install the nocking point so that the arrow passes the center of the arrowrest mounting hole and runs slightly point-down relative to the tuning mark on the window of the bow.

Release Aid shooters: Install the nocking point so that the arrow passes the center of the arrowrest mounting hole and runs parallel to the alignment mark on the window of the bow.

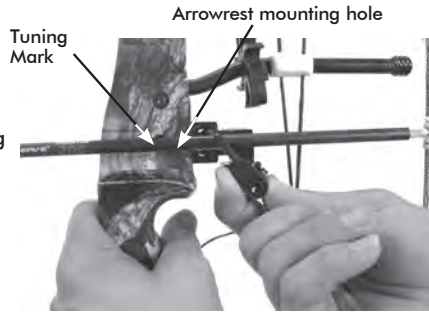

ARROWREST ADJUSTMENT:

When shooting with a release aid, the in/out position of the arrowrest should be adjusted so that the arrow runs parallel with the tuning mark on the shelf when viewed from above. When shooting with fingers the arrow should point slightly outside the tuning mark on the shelf.

NOTE: Alignment marks are for reference only.

Adjustments will likely be necessary to nocking point and in/out position during tuning

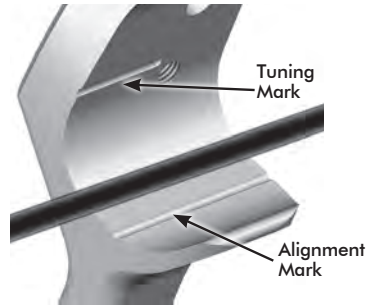

SIGHT ADJUSTMENT:

When adjusting the sight pin locations, always remember to "follow the group". That is, if the shot group is to the left of the target, move the sight pins to the left. If the shot group is low, move the sight pins down.

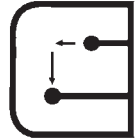

CABLE GUARD ADJUSTMENT AND INSTALLATION:

Install the cable guard as shown in Figure A. Adjust the cable guard so the cables just clear the arrow vanes. On bows using an offset cable guard rod, adjustments must be done with the rod in the up position (approximately 2 o'clock) as shown in Figure B (10 o'clock for left handed bows). Over-rotating an adjustable cable guard creates excessive arrow clearance and may cause the cable to track incorrectly on the wheels and cause personal injury and/or damage to the bow.

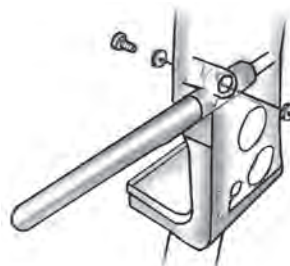

Figure A

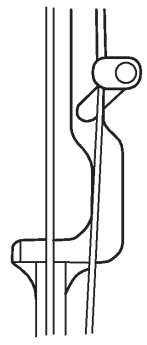

Figure B

FLEXSLIDE™ ADJUSTMENT & INSTALLATION

The PSE FlexSlide™ cable guard system is based on the same advanced design and analysis used to create PSE Limbs. The flex-tuned design and adjustable offset are engineered to create more consistent lateral loads through the draw cycle and improve bow accuracy.

1. The standard factory setting adjusts the FlexSlide™ to its bottom position for maximum arrow clearance.
2. To adjust the lateral position, turn the adjustment screw counterclockwise to reduce arrow clearance or clockwise to increase arrow clearance.
3. After making adjustments to your FlexSlide™, check both arrow clearance and BackStop™ clearance. When drawing the bow, the buss cable should never contact the arrow shaft or any part of the Backstop™.
4. If any contact exists, tighten the adjustment screw to create adequate clearance. One full turn on the adjustment screw will move the slide approximately 1/8".

NOTE: Lateral adjustments to the FlexSlide™ may affect arrow tuning.

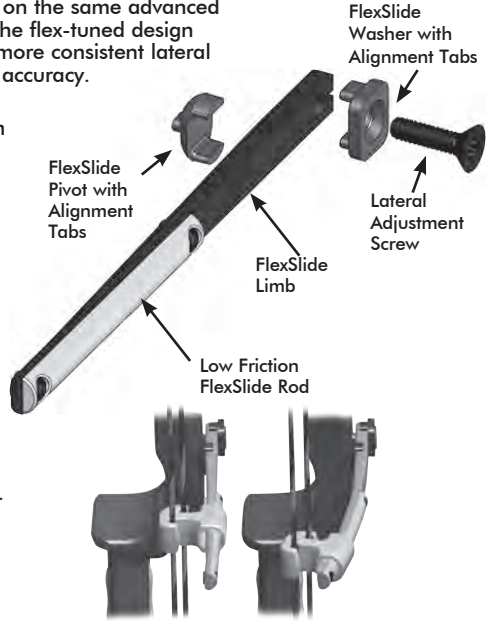

BACKSTOP™ 2 INSTRUCTIONS

Note: Most PSE Pro Series bow models come from the factory with the Backstop™ 2 installed. These instructions refer to reinstallation or adjustment if needed after making adjustments to your PSE bow.

1. Remove the setscrews from the base using a 1/16" hex wrench.
2. Install the Backstop™ 2 into the threaded hole below the grip on the string-facing side of the bow.
3. Extend the Backstop™ 2 until it makes contact with the string. Mark the string 1/4" above and 1/4" below where it makes contact with the string. Remove the Backstop™ 2 and add serving to that area of the string. Reinstall the Backstop™ 2.
4. Securely tighten the base to the bow handle.
6. Extend rod from base. Install the setscrews to secure rod in this position. Tighten setscrews. It is desired to have some clearance (approximately 1/16") between the bumper and the bowstring at brace.

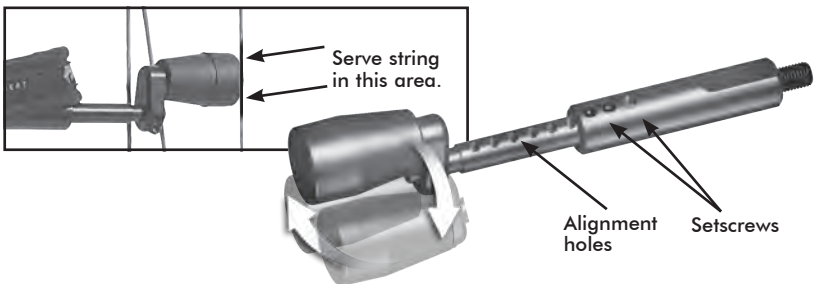

STING STOP™ INSTRUCTIONS



Note: Some PSE bow models come from the factory with the PSE Sting Stop™ Backstop installed. These instructions refer to reinstallation or adjustment if needed after making adjustments to your PSE bow.

1. Thread the Sting Stop™ nut all the way up toward the bumper of the Sting Stop™ rod.
2. Thread the Sting Stop™ rod into the threaded hole below the grip on the riser. The bowstring will need to be displaced slightly to one side to thread the rod into the bow.
3. Unscrew the Sting Stop™ until the rubber bumper approaches the bowstring. Mark the string 1/4" above the rubber bumper in its highest position and 1/4" below the bumper in its lowest position. Remove the Sting Stop™ and add serving to the marked area of the string. Reinstall the Sting Stop™.
4. Adjust the Sting Stop™ to the desired position and tighten the Sting Stop™ nut against the riser. The Sting Stop™ design allows for the bumper to be positioned so the string strikes the center of the bumper. It is desired to have some clearance (approximately 1/16") between the bumper and the bowstring at brace. It is preferred to have the Sting Stop™ rod in the up position if possible, but may not be possible in order to achieve the necessary clearance and contact point.

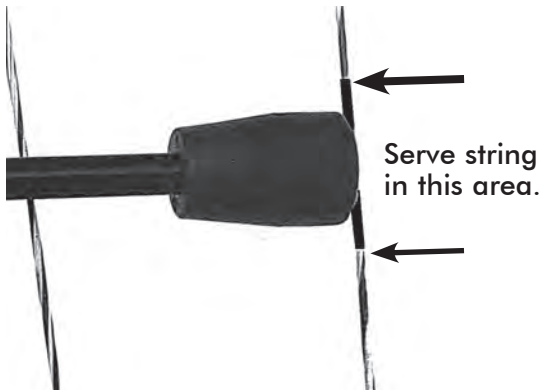

INSTALLATION OF ACCESSORIES

Arrowrest/Overdraw: The arrowrest or overdraw should be installed according to the instructions received with the product. It is usually mounted to the riser in the threaded hole on the side opposite the shelf (Hole "A") using the hardware provided with the arrowrest or overdraw.

Sight: The sight should be installed according to the instructions received with the product. It is usually mounted to the riser in the threaded holes (Holes "B") on the side opposite the shelf using the hardware provided with the sight. Some bows are equipped with multiple sight mounting holes which allow the sight to be moved up or down.

Stabilizer: The stabilizer should be mounted according to the manufacturer's recommendation. It is usually mounted in the threaded hole on the front of the riser (Hole "C").

Bow Sling: The bow sling attaches to the riser of the bow generally with the stabilizer. If a stabilizer is not used, attach the sling to the riser with the correct sized bolt (5/16" - 24) using the hole provided for the stabilizer (Hole "C").

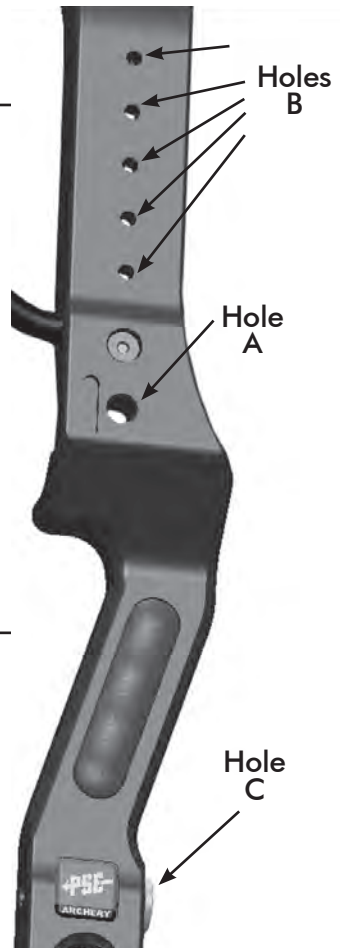

OTHER ADJUSTMENTS

Draw Weight: Your bow is factory-set to within 2 lbs. of the peak draw weight indicated on the bow hang tag and the last 2 digits of the serial number. Changes in draw weight can be made by turning the limb bolt in or out. Before making any changes in weight, turn the limb bolt clockwise to the bottom position. Never use extreme torque when turning the bolt or damage to the limb may occur. The limb bolt may then be turned counterclockwise to obtain the desired weight, but NEVER more than the number of turns indicated on the hang tag. Adjust each limb exactly the same. (See note and Fig. A below)

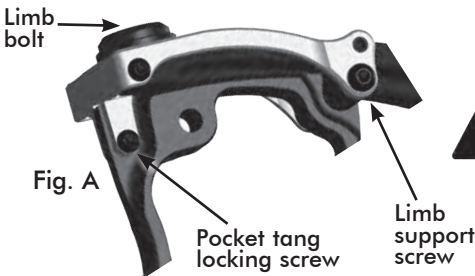

CAUTION: On some bow models, the limb bolt locking screw, limb support screws or pocket tang locking screw **MUST** be loosened **BEFORE** adjusting.

Wheels/Cams: Many PSE wheels and cams have adjustable features. Each one comes from the factory set up and ready to use but there may be occasions that you need to adjust the characteristics of your bow. In some cases you will need a PSE Tune Chart to determine what to adjust, and you may need to see a PSE Dealer for information. If you are not sure of the adjustment you are making, stop and see your PSE Dealer for assistance. In many cases, an appropriate bow press will be needed to make adjustments to cams and wheels. If you do not have an appropriate press, see your PSE Dealer.

Your Authorized PSE Dealer is supplied with technical information on PSE bows and cams. Please see your Dealer for assistance when making these adjustments.

INSTALLING LIMB BANDS AND CABLE GUARD DAMPER

If your bow is equipped with a Cable Guard Damper it should be even with the cable slide when the bow is at rest. More than one Cable Guard Damper can be used.

If your solid limb bow is equipped with limb bands, the proper placement of the bands is approximately 1/8" beyond the limb fork.

If your split limb bow is equipped with limb bands, the proper placement of the bands is at least 1/4" away from the cam (align the band with the end of the limb graphic). * Not standard on all models

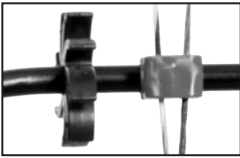

Cable Guard Damper
(Shown at full draw)



Limb Band Damper



Cable Guard Damper

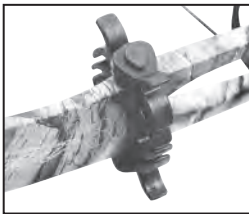

Limb Band on
Solid Limb



Limb Bands across
Split Limb



Limb Bands on
Split Limb (one per limb)

PSE ASYMMETRIC IDLER

PSE single cam bows are equipped with a special asymmetric idler wheel, which is assembled on the top limb. It is essential that the idler be oriented properly.

The wide edge of the idler always goes to the cable guard side of the bow.

The illustration shows the proper orientation of the idler for a right-handed bow when viewed while holding the bow as it is shot.

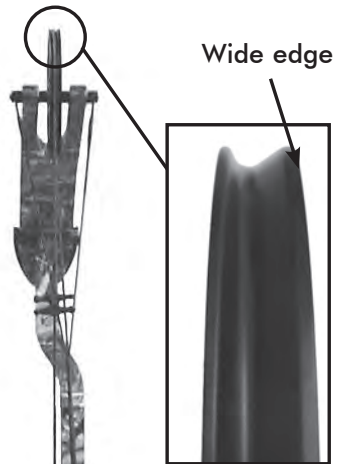

CAM ADJUSTMENTS

CAM ORIENTATION:

On cams with orientation marks, a reference mark is found to indicate an approximate orientation. This line is for reference only and is meant to give approximate orientation only and may vary between bow models. The orientation of the cams may be changed slightly by twisting or untwisting the string or cables. If attaching the string to the "+" post, the orientation marks will not be aligned with the cable.

DRAW LENGTH:

STRING POST ADJUSTMENTS

Some PSE cams have string post adjustments for draw length. For minor changes in draw length, the bow must be placed in a suitable bow press and tension relieved from the string and cable. The string side of the cam may have additional posts. Moving the string from the post with the dot to the post with the "+" will increase draw by approximately $\frac{1}{4}$ ". Moving the string from the post with the dot to the post with the "-" will decrease draw by approximately $\frac{1}{4}$ ".

ALL INNER-CAMS:

The inner-cam system allows draw length adjustments over a prescribed range usually without putting the bow in a bow press. There are two types of inner-cam systems: discrete setting inner-cams and Posi-Lock inner-cams.

Discrete setting inner-cams have the adjustment screws going through a specific hole in the inner-cam and threading into the cam. The screws need to be completely removed to make adjustments. The "A" setting is the longest draw length for that bow and draw lengths get shorter as you progress through the alphabet (A to B, B to C, etc.)

Posi-lock adjustable inner-cams are adjustable in $\frac{1}{2}$ " draw length increments. The "A" setting is the longest setting for the cam. Draw lengths get shorter as you progress through the alphabet ("A" to "B", "B" to "C", etc.) by roughly $\frac{1}{2}$ " per letter.

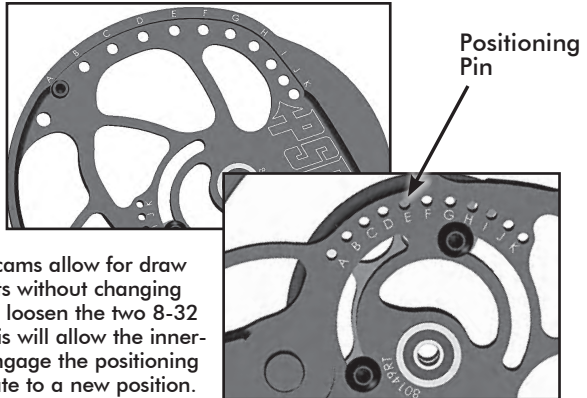

Second generation Posi-lock inner-cams allow for draw length adjustments in $\frac{1}{2}$ " increments without changing inner-cams. To adjust draw length, loosen the two 8-32 button head screws 2 full turns. This will allow the inner-cam to be lifted far enough to disengage the positioning pin and allow the inner-cam to rotate to a new position. Some cams may require the 8-32 button head screws to move to alternate locations to reach the new draw length adjustment position. Some draw length adjustment positions may not be accessible without putting the bow in a bow press. When the new draw length adjustment position has been achieved with the inner-cam, tighten the two 8-32 button head screws and move the draw stop to the matching setting ("A" and "A", "B" and "B").

In cases where there is an inner-cam on both the top and bottom cam, both cams must be set in the same letter position for the bow to tune and shoot properly. In cases where there is a separate draw stop, the draw stop must be moved to the hole marked with the letter corresponding to the inner-cam setting.

PSE "FC" FLEXIBLE, "AD" ADAPTA CAM AND "OP" OPTI CAM INFORMATION

INSTRUCTIONS:

The FC, AD and OP cam systems each consist of 2 cams with rotating inner-cams for adjusting draw length. In addition, the cam design has two draw weight settings. In the Fixed Peak Weight setting (see Figure 1) the peak draw weight stays the same regardless of the draw length setting. In the "Grow With You" setting (see Figure 2) the peak draw weight gets lighter as the draw length is adjusted shorter. The cable is easily pulled over the "Grow with You" boss peg to make the adjustment from fixed peak weight to the "Grow with You" setting- or back. No bow press is required for this adjustment.

DRAW LENGTH ADJUSTMENT - PSE "FC"- FLEXIBLE CAM AND "AD" ADAPTA CAM:

The inner-cam has holes marked "A" through "J" for adjusting draw length (see Figure 3) as well as a set of threaded holes marked "S" and "L". The "L" holes are used for longer draw lengths and the "S" holes are used for shorter draw lengths (see Figure 4). See the table for the setting required to achieve different draw lengths and weight.

To make the necessary adjustment, remove the screw holding the inner-cam in place and rotate the inner-cam so the letter setting desired lines up with the threaded "L" or "S" hole in the cam. Replace and tighten the screw. **IT IS IMPORTANT THAT BOTH TOP AND BOTTOM CAMS BE ADJUSTED THE SAME.** These adjustments can be made either with or without a bow press.

PSE "FC" AND "AD" ADAPTA CAM FLEXIBLE CAM ADJUSTMENTS:

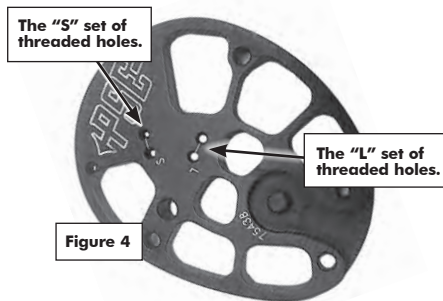
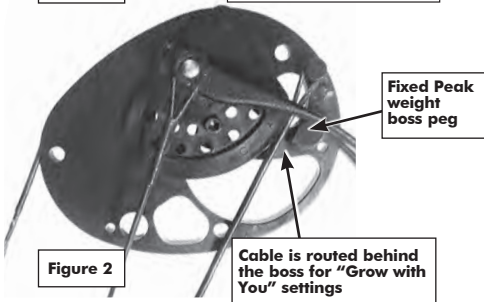
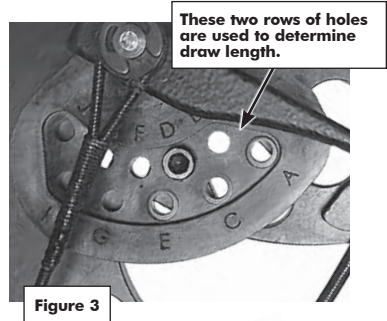
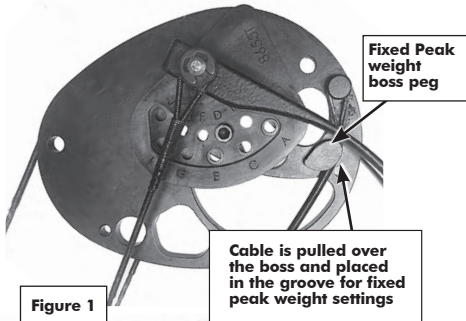

PSE MINI BURNER™ FC CAM ADJUSTMENTS:

PSE MINI BURNER 20# MODEL								
	FIXED PEAK WEIGHT SETTINGS				GROW WITH YOU SETTINGS			
MODULE SETTING	DRAW LENGTH	DRAW LENGTH (6 turns off)	PEAK DRAW WEIGHT	DRAW WEIGHT (6 turns off)	DRAW LENGTH	DRAW LENGTH (6 turns off)	PEAK DRAW WEIGHT	DRAW WEIGHT (6 turns off)
A-L	26	26 3/8	20	15	26	26 3/8	19	15
B-L	25 1/4	25 5/8	20	15	25 1/8	25 1/2	19	15
C-L	24 5/8	25	20	15	24 3/8	24 3/4	19	15
D-L	24	24 3/8	20	15	23 5/8	24	19	15
E-L	23 3/8	23 3/4	20	15	23	23 3/8	19	15
F-L	22 3/4	23 1/8	20	15	22 1/4	22 5/8	19	15
G-L	22 1/8	22 1/2	20	15	21 5/8	22	19	15
H-L	21 1/2	21 7/8	20	15	21	21 3/8	18 1/2	14
I-L	20 7/8	21 1/4	20	15	20 3/8	20 3/4	18	14
J-L	20 1/8	20 1/2	20	15	19 5/8	20	17 1/4	13
G-S	19 1/2	19 7/8	20	15	18 7/8	19 1/4	16 1/2	12 1/2
H-S	18 3/4	19 1/8	20	15	18 1/8	18 1/2	15 1/2	11 3/4
I-S	18	18 3/8	20	15	17 1/8	17 1/2	14 1/2	10 1/2
J-S	17	17 3/8	20	15	16	16 3/8	13	9

PSE MINI BURNER 29# MODEL								
	FIXED PEAK WEIGHT SETTINGS				GROW WITH YOU SETTINGS			
MODULE SETTING	DRAW LENGTH	DRAW LENGTH (6 turns off)	PEAK DRAW WEIGHT	DRAW WEIGHT (6 turns off)	DRAW LENGTH	DRAW LENGTH (6 turns off)	PEAK DRAW WEIGHT	DRAW WEIGHT (6 turns off)
A-L	26	26 3/8	29	21 1/2	26	26 3/8	26	19
B-L	25 1/4	25 5/8	29	21 1/2	25 1/8	25 1/2	26	19
C-L	24 5/8	25	29	21 1/2	24 3/8	24 3/4	26	19
D-L	24	24 3/8	29	21 1/2	23 5/8	24	26	19
E-L	23 3/8	23 3/4	29	21 1/2	23	23 3/8	26	19
F-L	22 3/4	23 1/8	29	21 1/2	22 1/4	22 5/8	26	19
G-L	22 1/8	22 1/2	29	21 1/2	21 5/8	22	26	19
H-L	21 1/2	21 7/8	29	21 1/2	21	21 3/8	25 3/4	18 1/2
I-L	20 7/8	21 1/4	29	21 1/2	20 3/8	20 3/4	25	18
J-L	20 1/8	20 1/2	29	21 1/2	19 5/8	20	24 1/4	17 1/4
G-S	19 1/2	19 7/8	29	21 1/2	18 7/8	19 1/4	23	16
H-S	18 3/4	19 1/8	29	21 1/2	18 1/8	18 1/2	22	15 1/2
I-S	18	18 3/8	29	21 1/2	17 1/8	17 1/2	20 1/2	14
J-S	17	17 3/8	29	21 1/2	16	16 3/8	20 1/2	14

PSE MINI BURNER 40# MODEL								
	FIXED PEAK WEIGHT SETTINGS				GROW WITH YOU SETTINGS			
MODULE SETTING	DRAW LENGTH	DRAW LENGTH (6 turns off)	PEAK DRAW WEIGHT	DRAW WEIGHT (6 turns off)	DRAW LENGTH	DRAW LENGTH (6 turns off)	PEAK DRAW WEIGHT	DRAW WEIGHT (6 turns off)
A-L	26	26 3/8	40	30	26	26 3/8	35	25
B-L	25 1/4	25 5/8	40	30	25 1/8	25 1/2	35	25
C-L	24 5/8	25	40	30	24 3/8	24 3/4	35	25
D-L	24	24 3/8	40	30	23 5/8	24	35	25
E-L	23 3/8	23 3/4	40	30	23	23 3/8	35	25
F-L	22 3/4	23 1/8	40	30	22 1/4	22 5/8	35	25
G-L	22 1/8	22 1/2	40	30	21 5/8	22	35	25
H-L	21 1/2	21 7/8	40	30	21	21 3/8	37	24 1/2
I-L	20 7/8	21 1/4	40	30	20 3/8	20 3/4	36 3/4	24
J-L	20 1/8	20 1/2	40	30	19 5/8	20	35 1/2	22 3/4
G-S	19 1/2	19 7/8	40	30	18 7/8	19 1/4	34	21 1/2
H-S	18 3/4	19 1/8	40	30	18 1/8	18 1/2	32 1/4	20 1/4
I-S	18	18 3/8	40	30	17 1/8	17 1/2	30 1/2	19
J-S	17	17 3/8	40	30	16	16 3/8	27	17 1/2



PSE CHAOS™ AD CAM ADJUSTMENTS:

CHAOS AD 29# MODEL								
	FIXED PEAK WEIGHT SETTINGS				GROW WITH YOU SETTINGS			
SETTING	DRAW LENGTH BOTTOM	DRAW LENGTH (8 turns off)	PEAK DRAW WEIGHT	DRAW WEIGHT (8 turns off)	DRAW LENGTH BOTTOM	DRAW LENGTH (8 turns off)	PEAK DRAW WEIGHT	DRAW WEIGHT (8 turns off)
A-L	28	28 1/4	29	18	27 3/4	28	26	16
B-L	27 1/4	27 1/2	29	18	27	27 1/4	26	16
C-L	26 1/4	26 1/2	29	18	26	26 1/4	26	16
D-L	25 1/2	25 3/4	29	18	25 1/4	25 1/2	26	16
E-L	24 3/4	25	29	18	24 1/2	24 3/4	26	16
F-L	24	24 1/4	29	18	23 3/4	24	26	16
G-L	23 1/4	23 1/2	29	18	23	23 1/4	26	16
H-L	22 1/4	22 1/2	29	18	22	22 1/4	26	15 1/2
I-L	21 3/4	22	29	18	21 1/2	21 3/4	25	14
J-L	20 1/2	20 3/4	29	18	20	20 1/4	24	13
G-S	19 3/4	20	29	18	19 1/2	19 3/4	22	12
H-S	19	19 1/4	29	18	18 1/4	18 1/2	22	12
I-S	18 1/2	18 3/4	29	18	18	18 1/4	20	11
J-S	17 1/2	17 3/4	29	18	16	16 1/2	18	9

CHAOS AD 40# MODEL								
	FIXED PEAK WEIGHT SETTINGS				GROW WITH YOU SETTINGS			
SETTING	DRAW LENGTH BOTTOM	DRAW LENGTH (8 turns off)	PEAK DRAW WEIGHT	DRAW WEIGHT (8 turns off)	DRAW LENGTH BOTTOM	DRAW LENGTH (8 turns off)	PEAK DRAW WEIGHT	DRAW WEIGHT (8 turns off)
A-L	28	28 1/4	40	25	27 3/4	28	37	23
B-L	27 1/4	27 1/2	40	25	27	27 1/4	37	23
C-L	26 1/4	26 1/2	40	25	26	26 1/4	37	23
D-L	25 1/2	25 3/4	40	25	25 1/4	25 1/2	37	23
E-L	24 3/4	25	40	25	24 1/2	24 3/4	37	23
F-L	24	24 1/4	40	25	23 3/4	24	37	23
G-L	23 1/4	23 1/2	40	25	23	23 1/4	37	23
H-L	22 1/4	22 1/2	40	25	22	22 1/4	35	20 1/2
I-L	21 3/4	22	40	25	21 1/2	21 3/4	34	19
J-L	20 1/2	20 3/4	40	25	20	20 1/4	31	17
G-S	19 3/4	20	40	25	19 1/2	19 3/4	29	16
H-S	19	19 1/4	40	25	18 1/4	18 1/2	29	16
I-S	18 1/2	18 3/4	40	25	18	18 1/4	27	15
J-S	17 1/2	17 3/4	40	25	16	16 1/2	27	14

Chaos™ AD adjustments continued on next page



PSE CHAOS™ AD CAM ADJUSTMENTS: Continued from previous page

CHAOS AD 50# MODEL								
SETTING	FIXED PEAK WEIGHT SETTINGS				GROW WITH YOU SETTINGS			
	DRAW LENGTH BOTTOM	DRAW LENGTH (8 turns off)	PEAK DRAW WEIGHT	DRAW WEIGHT (8 turns off)	DRAW LENGTH BOTTOM	DRAW LENGTH (8 turns off)	PEAK DRAW WEIGHT	DRAW WEIGHT (8 turns off)
A-L	28	28 1/4	50	31	27 3/4	28	47	29
B-L	27 1/4	27 1/2	50	31	27	27 1/4	47	29
C-L	26 1/4	26 1/2	50	31	26	26 1/4	47	29
D-L	25 1/2	25 3/4	50	31	25 1/4	25 1/2	47	29
E-L	24 3/4	25	50	31	24 1/2	24 3/4	47	29
F-L	24	24 1/4	50	31	23 3/4	24	47	29
G-L	23 1/4	23 1/2	50	31	23	23 1/4	47	29
H-L	22 1/4	22 1/2	50	31	22	22 1/4	47	27 1/2
I-L	21 3/4	22	50	31	21 1/2	21 3/4	45 3/4	25
J-L	20 1/2	20 3/4	50	31	20	20 1/4	43	24
G-S	19 3/4	20	50	31	19 1/2	19 3/4	40	22 1/2
H-S	19	19 1/4	50	31	18 1/4	18 1/2	36 1/2	20 1/2
I-S	18 1/2	18 3/4	50	31	18	18 1/4	34	19
J-S	17 1/2	17 3/4	50	31	16	16 1/2	31	16

CHAOS AD 60# MODEL								
SETTING	FIXED PEAK WEIGHT SETTINGS				GROW WITH YOU SETTINGS			
	DRAW LENGTH BOTTOM	DRAW LENGTH (8 turns off)	PEAK DRAW WEIGHT	DRAW WEIGHT (8 turns off)	DRAW LENGTH BOTTOM	DRAW LENGTH (8 turns off)	PEAK DRAW WEIGHT	DRAW WEIGHT (8 turns off)
A-L	28	28 1/4	60	37	27 3/4	28	54	33 1/2
B-L	27 1/4	27 1/2	60	37	27	27 1/4	54	33 1/2
C-L	26 1/4	26 1/2	60	37	26	26 1/4	54	33 1/2
D-L	25 1/2	25 3/4	60	37	25 1/4	25 1/2	54	33 1/2
E-L	24 3/4	25	60	37	24 1/2	24 3/4	54	33 1/2
F-L	24	24 1/4	60	37	23 3/4	24	54	33 1/2
G-L	23 1/4	23 1/2	60	37	23	23 1/4	54	33 1/2
H-L	22 1/4	22 1/2	60	37	22	22 1/4	53	31
I-L	21 3/4	22	60	37	21 1/2	21 3/4	52	29
J-L	20 1/2	20 3/4	60	37	20	20 1/4	52	28
G-S	19 3/4	20	60	37	19 1/2	19 3/4	47	26 1/2
H-S	19	19 1/4	60	37	18 1/4	18 1/2	44 1/2	25
I-S	18 1/2	18 3/4	60	37	18	18 1/4	40	22 1/2
J-S	17 1/2	17 3/4	60	37	16	16 1/2	36	18



PSE RALLY™ OP CAM ADJUSTMENTS AND SETTINGS:

PSE RALLY™ CAM INFORMATION

PSE RALLY™ OP CAM ADJUSTMENTS AND SETTINGS:

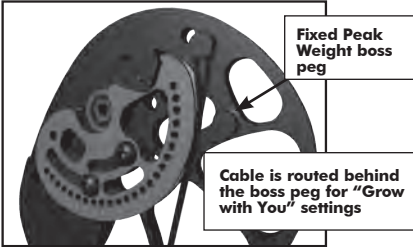

Cable in the "Grow with You" setting

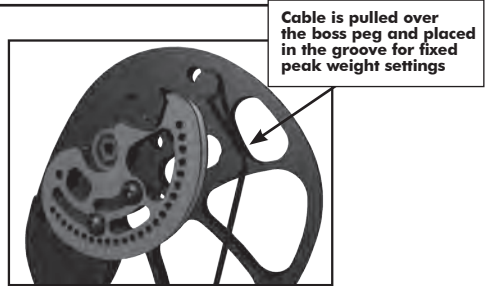

Cable in the "Fixed Peak Weight" setting

DRAW LENGTH ADJUSTMENT - "OP" OPTI CAM:

The inner-cam has holes marked "A" through "X" for adjusting draw length. See the table for the setting required to achieve different draw lengths and weights. To make the necessary adjustment, loosen the 8-32 button head screws two full turns. "A" is the longest draw length setting and draw lengths get shorter as you move up the alphabet ("A" to "B", "B" to "C", etc.). The Opti Cam inner-cams adjust from "A" to "H" and then require the 8-32 screws be removed and repositioned to adjust from "I" to "P".

PSE RALLY 50# MODEL								
MODULE SETTING	FIXED PEAK WEIGHT SETTINGS				GROW WITH YOU SETTINGS			
	DRAW LENGTH	DRAW LENGTH (10 turns off)	PEAK DRAW WEIGHT	DRAW WEIGHT (10 turns off)	DRAW LENGTH	DRAW LENGTH (10 turns off)	PEAK DRAW WEIGHT	DRAW WEIGHT (10 turns off)
A	31	31 1/8	50	32	30 7/8	31	50	32
B	30 1/2	30 5/8	50	32	30 3/8	30 1/2	50	32
C	30	30 1/8	50	30	29 7/8	30	49	30
D	29 1/2	29 5/8	50	30	29 3/8	29 1/2	49	29
E	29	29 1/8	50	30	28 7/8	29	49	29
F	28 1/2	28 5/8	50	30	28 3/8	28 1/2	48	29
G	28	28 1/8	50	30	27 7/8	28	48	27
H	27 1/2	27 5/8	50	29	27 1/4	27 3/8	48	27
I	27	27 1/8	50	28	26 3/4	27	48	26
J	26 1/2	26 5/8	50	27	26 1/8	26 1/4	47	26
K	26	26 1/8	50	27	25 1/2	25 5/8	47	25
L	25 1/4	25 3/8	50	26	25	25 1/4	47	25
M	24 3/4	24 7/8	50	26	24 3/8	24 5/8	46	24
N	24	24 1/8	50	26	23 7/8	24 1/8	45	23
O	23 1/2	23 5/8	50	25	23 1/4	23 1/2	44	23
P	23	23 1/8	50	25	22 3/4	22 7/8	43	22
Q	22 1/2	22 5/8	50	25	22 1/8	22 1/4	42	22
R	22	22 1/8	50	25	21 5/8	21 3/4	41	20
S	21 1/2	21 5/8	50	25	21	21 1/4	39	19
T	21	21 1/8	50	25	20 1/2	20 3/4	38	18
U	20 1/2	20 5/8	50	25	19 7/8	20 1/8	36	17
V	20	20 1/8	50	25	19 3/8	19 5/8	34	16
W	19 1/2	19 5/8	50	25	18 3/4	19	32	16
X	19	19 1/8	50	25	18 1/4	18 1/2	31	14



PSE RALLY™ OP CAM ADJUSTMENTS AND SETTINGS: (CONTINUED)

PSE RALLY 60# MODEL								
MODULE SETTING	FIXED PEAK WEIGHT SETTINGS				GROW WITH YOU SETTINGS			
	DRAW LENGTH	DRAW LENGTH (10 turns off)	PEAK DRAW WEIGHT	DRAW WEIGHT (10 turns off)	DRAW LENGTH	DRAW LENGTH (10 turns off)	PEAK DRAW WEIGHT	DRAW WEIGHT (10 turns off)
A	31	31 1/8	60	38	30 7/8	31	59	38
B	30 1/2	30 5/8	60	38	30 3/8	30 1/2	59	37
C	30	30 1/8	60	38	29 7/8	30	58	35
D	29 1/2	29 5/8	60	38	29 3/8	29 1/2	58	35
E	29	29 1/8	60	38	28 7/8	29	58	35
F	28 1/2	28 5/8	60	38	28 3/8	28 1/2	58	35
G	28	28 1/8	60	37	27 7/8	28	58	34
H	27 1/2	27 5/8	60	36	27 1/4	27 3/8	58	32
I	27	27 1/8	60	35	26 3/4	27	58	32
J	26 1/2	26 5/8	60	34	26 1/8	26 1/4	57	31
K	26	26 1/8	60	33	25 1/2	25 5/8	57	31
L	25 1/4	25 3/8	60	31	25	25 1/4	57	31
M	24 3/4	24 7/8	60	30	24 3/8	24 5/8	55	30
N	24	24 1/8	60	30	23 7/8	24 1/8	54	29
O	23 1/2	23 5/8	60	30	23 1/4	23 1/2	54	28
P	23	23 1/8	60	30	22 3/4	22 7/8	52	27
Q	22 1/2	22 5/8	60	30	22 1/8	22 1/4	51	26
R	22	22 1/8	60	30	21 5/8	21 3/4	50	25
S	21 1/2	21 5/8	60	30	21	21 1/4	48	24
T	21	21 1/8	60	30	20 1/2	20 3/4	46	22
U	20 1/2	20 5/8	60	30	19 7/8	20 1/8	44	21
V	20	20 1/8	60	30	19 3/8	19 5/8	42	20
W	19 1/2	19 5/8	60	30	18 3/4	19	39	20
X	19	19 1/8	60	30	18 1/4	18 1/2	38	18

PSE RALLY 70# MODEL								
MODULE SETTING	FIXED PEAK WEIGHT SETTINGS				GROW WITH YOU SETTINGS			
	DRAW LENGTH	DRAW LENGTH (10 turns off)	PEAK DRAW WEIGHT	DRAW WEIGHT (10 turns off)	DRAW LENGTH	DRAW LENGTH (10 turns off)	PEAK DRAW WEIGHT	DRAW WEIGHT (10 turns off)
A	31	31 1/8	70	45	30 7/8	31	68	44
B	30 1/2	30 5/8	70	45	30 3/8	30 1/2	68	43
C	30	30 1/8	70	45	29 7/8	30	68	43
D	29 1/2	29 5/8	70	45	29 3/8	29 1/2	68	42
E	29	29 1/8	70	44	28 7/8	29	68	42
F	28 1/2	28 5/8	70	44	28 3/8	28 1/2	68	42
G	28	28 1/8	70	43	27 7/8	28	68	40
H	27 1/2	27 5/8	70	42	27 1/4	27 3/8	67	39
I	27	27 1/8	70	41	26 3/4	27	67	38
J	26 1/2	26 5/8	70	40	26 1/8	26 1/4	67	38
K	26	26 1/8	70	40	25 1/2	25 5/8	66	37
L	25 1/4	25 3/8	70	39	25	25 1/4	66	37
M	24 3/4	24 7/8	70	38	24 3/8	24 5/8	65	36
N	24	24 1/8	70	37	23 7/8	24 1/8	64	35
O	23 1/2	23 5/8	70	37	23 1/4	23 1/2	62	34
P	23	23 1/8	70	37	22 3/4	22 7/8	61	32
Q	22 1/2	22 5/8	70	37	22 1/8	22 1/4	59	31
R	22	22 1/8	70	37	21 5/8	21 3/4	58	30
S	21 1/2	21 5/8	70	37	21	21 1/4	56	29
T	21	21 1/8	70	37	20 1/2	20 3/4	54	27
U	20 1/2	20 5/8	70	37	19 7/8	20 1/8	51	25
V	20	20 1/8	70	37	19 3/8	19 5/8	48	24
W	19 1/2	19 5/8	70	37	18 3/4	19	46	24
X	19	19 1/8	70	37	18 1/4	18 1/2	45	21

INFORMATION ON DRAW STOP ADJUSTMENTS:

DRAW STOP:

The position of the draw stop must match the setting on the inner-cam. For example, if the cam is set on "E", the draw stop must be placed in one of the draw stop holes marked with an "E". If the inner-cam is in the "B" setting, the stop must be in the "B" position. Certain hybrid cams have top and bottom stops. They can be shot with both stops for a harder "wall" or with only the top stop for a softer "wall". Never shoot hybrid cams with the two stop option with only the bottom stop. In either case, the stops need to be in the holes marked with the same marking as the inner-cam setting.

The Ultra Fast (UF) hybrid cam system (Fig. A) has two valley settings-long and short. When using top and bottom stops for a hard "wall" both stops need to be in the same hole designation-long or short.

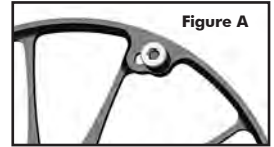

UF Cam (Omen Max)

PSE MAIN LINE BOWS: DRAW SETTING CHART

SETTING	PROPHECY	BOW MADNESS 3G	SINISTER	BRUTE X	STINGER 3G	CHAOS ONE
A	30	30	30 1/2	30	30 1/2	29
B	29 1/2	29 1/2	30	29 1/2	30	28 1/2
C	29	29	29 1/2	29	29 1/2	28
D	28 1/2	28 1/2	29	28 1/2	29	27 1/2
E	28	28	28 1/2	28	28 1/2	27
F	27 1/2	27 1/2	28	27 1/2	28	26 1/2
G	27	27	27 1/2	27	27 1/2	26
H	26 1/2	26 1/2	27	26 1/2	27	25 1/2
I	26	26	26 1/2	26	26 1/2	25
J	25 1/2	25 1/2	26	25 1/2	26	24 1/2
K	25	25	25 1/2	25	25 1/2	24



PSE PRO SERIES BOWS: DRAW SETTING CHART

SETTING	DNA	EVO MAX	HAMMER	VENDETTA	REVENGE	STILETTO	FREAK MAX	DRIVE
A	30	30	31	32	30	27 1/2	33	31 1/2
B	29 1/2	29 1/2	30 1/2	31 1/2	29 1/2	27	32 1/2	31
C	29	29	30	31	29	26 1/2	32	30 1/2
D	28 1/2	28 1/2	29 1/2	30 1/2	28 1/2	26	31 1/2	30
E	28	28	29	30	28	25 1/2	31	29 1/2
F	27 1/2	27 1/2	28 1/2	29 1/2	27 1/2	25	30 1/2	29
G	27	27	28	29	27	24 1/2	30	28 1/2
H	26 1/2	26 1/2	27 1/2	28 1/2	26 1/2	24	29 1/2	28
I	26	26	27	28	26	23 1/2	29	27 1/2
J		25 1/2	26 1/2	27 1/2	25 1/2	23	28 1/2	27
K		25	26	27	25		28	26 1/2
L				26 1/2	24 1/2			26



SETTING	DOMINATOR MAX	DOMINATOR 3D MAX	SUPRA MAX	PHENOM
A	31 1/2	30 1/2	30	30
B	31	30	29 1/2	29 1/2
C	30 1/2	29 1/2	29	29
D	30	29	28 1/2	28 1/2
E	29 1/2	28 1/2	28	28
F	29	28	27 1/2	27 1/2
G	28 1/2	27 1/2	27	27
H	28	27	26 1/2	26 1/2
I	27 1/2	26 1/2	26	26
J	27	26	25 1/2	25 1/2

PSE X TECHNOLOGY

The PSE X Technology bows come with many unique features that will enhance your archery experience.

MAINTENANCE

Your bow is a mechanical device that is subject to wear and therefore must be inspected periodically and given the proper adjustments and service. It is recommended that this service be performed at least once a year by an authorized PSE dealer. All components, including string, cables, axles, e-clips, limbs and riser should be carefully inspected for damage or wear.

STRINGS AND CABLES

Apply a light coat of high quality bowstring wax to your string and cable each time you shoot your bow. It is especially important NOT to wax the area of the string that wraps around the idler wheel. This area of the string should be treated with a cam lubricant. This will help reduce wear on your string and cables. Inspect the string and cables regularly and replace them when there is evidence of wear, every 5000 shots or every 12 months.

USING A BOW PRESS WITH X TECHNOLOGY BOWS

ALL PSE X Technology bows **MUST** be serviced in an approved bow press and require special consideration. Do not attempt to service these bows in any bow press without reviewing the procedures described herein.

Use of a non-approved bow press or improper use of an approved bow press **WILL** result in damage to the bow and possible personal injury. Damages incurred by improper use or maintenance will not be covered under the warranty. See the PSE website at www.pse-archery.com for a list of approved bow presses.

There are two basic types of approved presses available: compression-type and pull-type.

COMPRESSION-TYPE BOW PRESS:

This type of press pushes in a horizontal direction against the tips of the limbs. No other support for the bow is required.

When using a press of this type, back each limb bolt out 4 turns from the bottom setting, position the bow in the press and crank press inward to apply a compression force against the limb tips as shown below.



Compress **ONLY** far enough to loosen the string and cables. Over compressing could break the limbs and cause personal injury. Any damages incurred from over-compressing will not be covered under warranty.

COMPRESSION-TYPE BOW PRESS

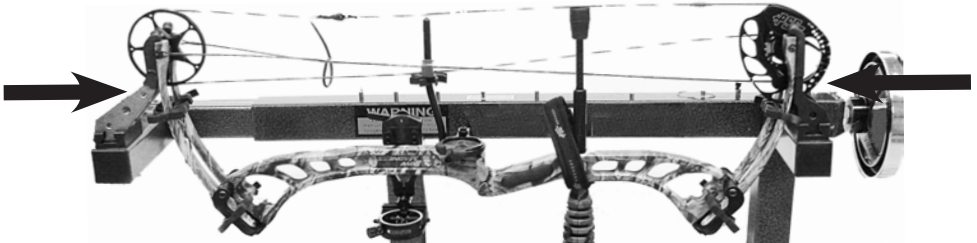

X Technology continued on next page



PSE X TECHNOLOGY USING A BOW PRESS (Continued)

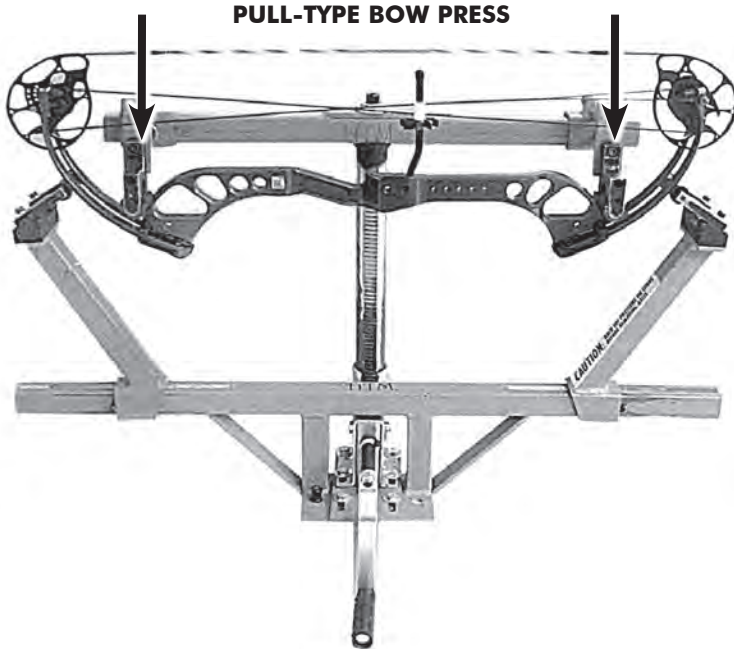

PULL-TYPE BOW PRESS:

This type of press pulls the riser of the bow in a vertical direction between rollers that compress the limbs.



When using this type press it is very important to position the rollers and pressure points correctly! See illustration above.

Back the limb bolts out 4 turns from the bottom setting and position the pressure points on the riser as close to the limbs as possible **WITHOUT** making contact with the limbs as shown in the photo below.



The pressure points must not contact the limbs **AT ANY TIME** during servicing.

PULL-TYPE BOW PRESS

X Technology continued on next page

PSE X TECHNOLOGY USING A BOW PRESS (Continued)



Position the limb rollers outward on the limbs so that when the riser is pulled down the bow does not slip through/between the rollers before releasing tension on the string and cables. The rollers must be at least 4" from the limb pockets or the limbs will break. While placing tension on the limbs, **BE VERY CAREFUL NOT TO PULL THE RISER DOWN TOO FAR. DEFLECT THE LIMBS JUST ENOUGH TO REMOVE THE STRING AND CABLES.** Never allow the rollers to go past the end of the limb belly (thinnest part).

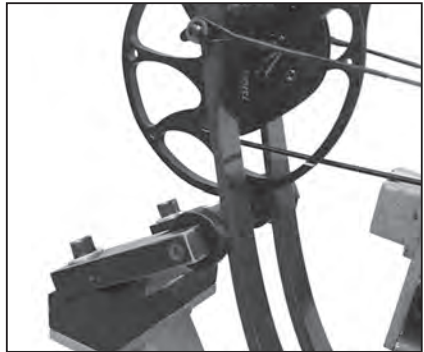
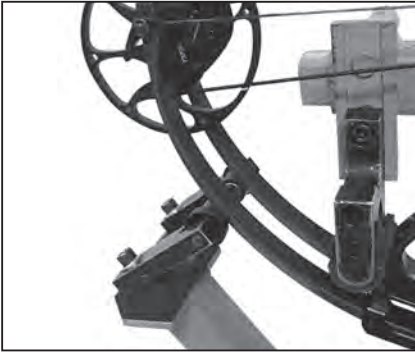

Service such as peep and string mounted vibration damper installation and string replacement can be performed with a Pocket Press portable bow press available from your local PSE dealer. Item #01031, #01164, #01165, #01169, #01170, #01184, #01185, #01186, #01187, and #01210 are pocket presses available for alternate axle-to-axle lengths and cam types.



SERVICING BOWS WITH PSE UF CAMS (PSE OMEN™ PRO) **CAUTION • CAUTION • CAUTION!**

When servicing bows with PSE UF cams, such as the OMEN™ PRO, it is important to use a bow press that has enough clearance for the cams.

On some bow presses the cams may make contact with the area shown in Figure 1 when compressing the limbs. Watch very carefully as the bow is compressed. If either cam comes in contact with the bow press, **STOP IMMEDIATELY or permanent damage to bow components may occur.**

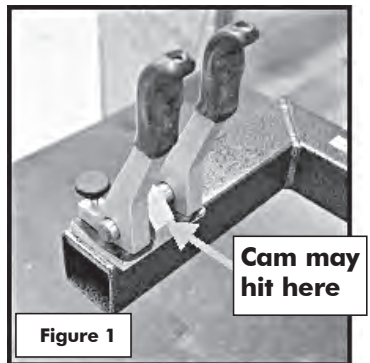

Figure 1



LOOKING FOR THE LATEST INFORMATION ON PSE PRODUCTS AND SERVICES?

PSE-ARCHERY.COM

The PSE website has numerous resources for the PSE owner:

- The latest PSE products
- Product feature videos
- Serial number search
- Online product registration
- Tune charts on PSE bows from 1991 to present
- Purchase accessories, PSE Signature Items and more!



PSE PATENT INFORMATION

Manufactured Under Patents:

5,365,650	6,112,732	D528,625
5,377,658	6,176,231	7,699,045
5,469,834	6,360,735	7,721,721
5,487,373	6,792,930	7,784,452
5,495,843	6,889,683	7,832,388
5,507,270	6,968,837	7,891,349
5,657,739	7,347,196 B1	7,918,218
5,678,529	RE36,942	7,980,236
5,762,060	D429,309	7,980,237
5,960,778	D503,958	

Licensed Under Patents:

5,392,756	5,921,227
5,501,208	6,237,584
5,505,185	6,588,411
5,749,351	6,966,314
5,894,835	



EXPERIENCE. PERFORMANCE.



LIMITED LIFETIME WARRANTY

Each PSE Bow is backed by a PSE Limited Lifetime Warranty to the original owner for the life of the product. Product will be replaced or repaired to restore it to its original performance. Cables, strings, or wearable items are not covered by this warranty.

Evidence of abuse, mishandling, misuse, or alteration to any PSE product voids any claim to warranty.

PSE specifications on strings and harnesses must be adhered to. PSE cannot be held responsible for injury or product failure resulting from improper use or neglect of maintenance.

All bows must undergo string and cable changes every 5,000 shots or every 12 months to maintain PSE warranty coverage. Total arrow weight must be in accordance with the guidelines published by the Archery Trade Association (ATA) for minimum arrow weight/bow peak weight. Overstressing PSE compound bows by using arrows lighter than ATA guideline will void warranty and may cause damage to the bow or injury to the shooter.

PSE makes no other claims either expressed or implied. In the interest of product improvement and consumer safety, PSE reserves the right to make changes in product design, color, and specifications without notice.

ONLINE WARRANTY REGISTRATION

Log on at: www.pse-archery.com/registration



The PSE serial number is laser etched into your riser- opposite the shelf area



EXPERIENCE. PERFORMANCE.

PRECISION SHOOTING EQUIPMENT, INC.

2727 N. FAIRVIEW AVENUE, TUCSON, AZ 85705 520-884-9065

WWW.PSE-ARCHERY.COM

PN 80481 REV. MARCH 2013