

THANK YOU FOR CHOOSING PSE!



PRECISION SHOOTING EQUIPMENT INC.

2727 N. FAIRVIEW AVE. TUCSON, AZ 85705 • PSE-ARCHERY.COM

PN: 81480

PSE

ARCHERY



COMPOUND BOW USER'S GUIDE

Thank You!

Thank you from the entire PSE family for purchasing a PSE bow! Your bow was manufactured from the finest materials available and handcrafted with pride in the USA. With proper care you will enjoy the use of this product for years to come.

Please read this entire booklet before shooting or adjusting your bow. Remember, many adjustments to a compound bow require the use of a bow press. Whenever shooting a bow, be certain of your target as well as what else lies down range.

NOTE: IMPORTANT WARRANTY REGISTRATION INFORMATION IS ON PAGE 38

PSE COMPOUND BOW OWNER'S INFORMATION

Fill in the following information for your personal records.

Bow Model _____

Bow Serial Number: _____

See page 40 for the serial number location on your bow.

Purchased From: _____

Purchase Date: _____

Draw Length _____ Draw Weight _____

INDEX

SUBJECT	PAGE
Welcome to PSE and general product information	4
Compound bow terminology.....	5
PSE cable configurations.....	6
PSE X-Tech™ bow press info	7-9
Installation of accessories	10
Other adjustments	10
Setting up your bow.....	11
FlexSlide 2™ installation and adjustments.....	12
BackStop™ installation and adjustments	12
Sting Stop™ installation and adjustments.....	13
Shock-Modz installation and adjustments.....	13
Limb bands and cable guard dampers	14
Changing the FlexSlide™ rod.....	15
PSE asymmetric idler.....	15
Wedge Lock & LAS.....	16
Draw stop information.....	19
Limb stop adjustments.....	19
Cam adjustments.....	18
PSE Pro Series bows- draw setting charts	20
PSE Mainline bows- draw setting charts	21
PSE Stinger™ X with XS cam information	22-25
PSE Vision™ cam information.....	26
PSE Fever™ with Vision™ “performance” cam setting charts.....	27-28
PSE Fever™ with Vision™ “grow with you” cam setting charts.....	29-30
PSE Mini Burner™ XT with Vision™ “performance” setting charts.....	31-32
PSE Mini Burner™ XT with Vision™ “grow with you” setting charts	33-34
PSE limited lifetime warranty information	35
PSE Online store information	36-37
Notes.....	38
PSE warranty registration information.....	39

GENERAL OPERATING INSTRUCTIONS

- Always inspect your bow thoroughly before each shooting session to insure that it is in good working order. Check for worn, loose or missing components and have them replaced at an authorized PSE dealer as required, i.e. bushings, spacers, etc.
- Inspect your arrows to insure that they are straight, undamaged and that each nock is in good condition. A cracked nock can break when fired from the bow and cause the bow to "dry fire" resulting in possible injury to the archer and damage to the bow. Dry-firing is drawing and releasing the bowstring without an arrow on the string.
- When purchasing arrows for your bow, consult the selection chart from the arrow manufacturer and select the correct arrow for your application. Always use an arrow that is at least 5 grains per pound of peak bow weight. Failure to do so could cause personal injury and damage to your bow.

BOW MAINTENANCE

Your PSE bow will give you many years of use if maintained and cared for properly. It is a mechanical device that is subject to wear and therefore must be inspected periodically and given the proper adjustments and service. It is recommended that this service be performed at least once a year by an authorized PSE dealer. All components, including string, cables, axles, e-clips, limbs and riser should be carefully inspected for damage or wear.

STRINGS AND CABLES

Apply a light coat of high quality bowstring wax to your string and cable each time you shoot your bow. It is especially important **NOT** to wax the area of the string that wraps around the idler wheel. This area of the string should be treated with a cam lubricant. This will help reduce wear on your string and cables. Inspect the string and cables regularly and replace them when there is evidence of wear, every 5000 shots or every 12 months.



IMPORTANT: Before servicing any PSE bow in a bow press, back out each limb bolt the maximum number of turns from bottom.

- Keep synthetic cables and strings waxed. Apply bow string wax to your synthetic cables and string before each shooting session.
- Strings and cables must be replaced periodically. A worn cable or string can suddenly break causing serious injury to the archer and damage to the bow. It is recommended that the string and cables be replaced at least every 5,000 shots or 12 months.
PSE recommends that this work be performed by an authorized PSE dealer.
- Always store your bow in a cool dry place. High temperatures, such as those that can occur in the interior of a vehicle, can cause serious damage to your bow.
- After use in high humidity or damp conditions, wipe metal components of your bow with a light oil.



SAFETY

As with any weapon, safe operation of your PSE bow must always be the highest priority.

ALWAYS WEAR SAFETY GLASSES WHEN HANDLING A BOW.

Do not attempt to use your bow without proper instruction.

Doing so can result in serious injury.

- NEVER DRY-FIRE YOUR BOW.** Dry-firing is drawing and releasing the bowstring without an arrow on the string. Dry-firing will likely cause damage to the bow and serious injury to the archer. **In the event of a dry-fire, have an authorized PSE dealer inspect the bow for damage.**
- Always be sure of your intended target as well as what lies behind the target area. An arrow can travel a considerable distance, so it is important to have a safe and sound backstop.
- If you draw a bow and need to let it down, do so in a slow and careful manner. Keep your support arm straight and prepare for a rapid and violent let-down. Avoid hitting your hand on protruding accessories such as the cable guard or quiver. Keep your head and face back and out of danger during let-down. Never draw a bow with a peak weight above your comfort level. Always use a wrist sling when drawing a bow.
- Never modify any part of the bow or its components by drilling extra holes or removing material. This voids the warranty and presents safety problems.
- It is not recommended to time the bow using a draw board unless the draw board is operated by a winch or other mechanical pulling device.

COMPOUND BOW TERMINOLOGY

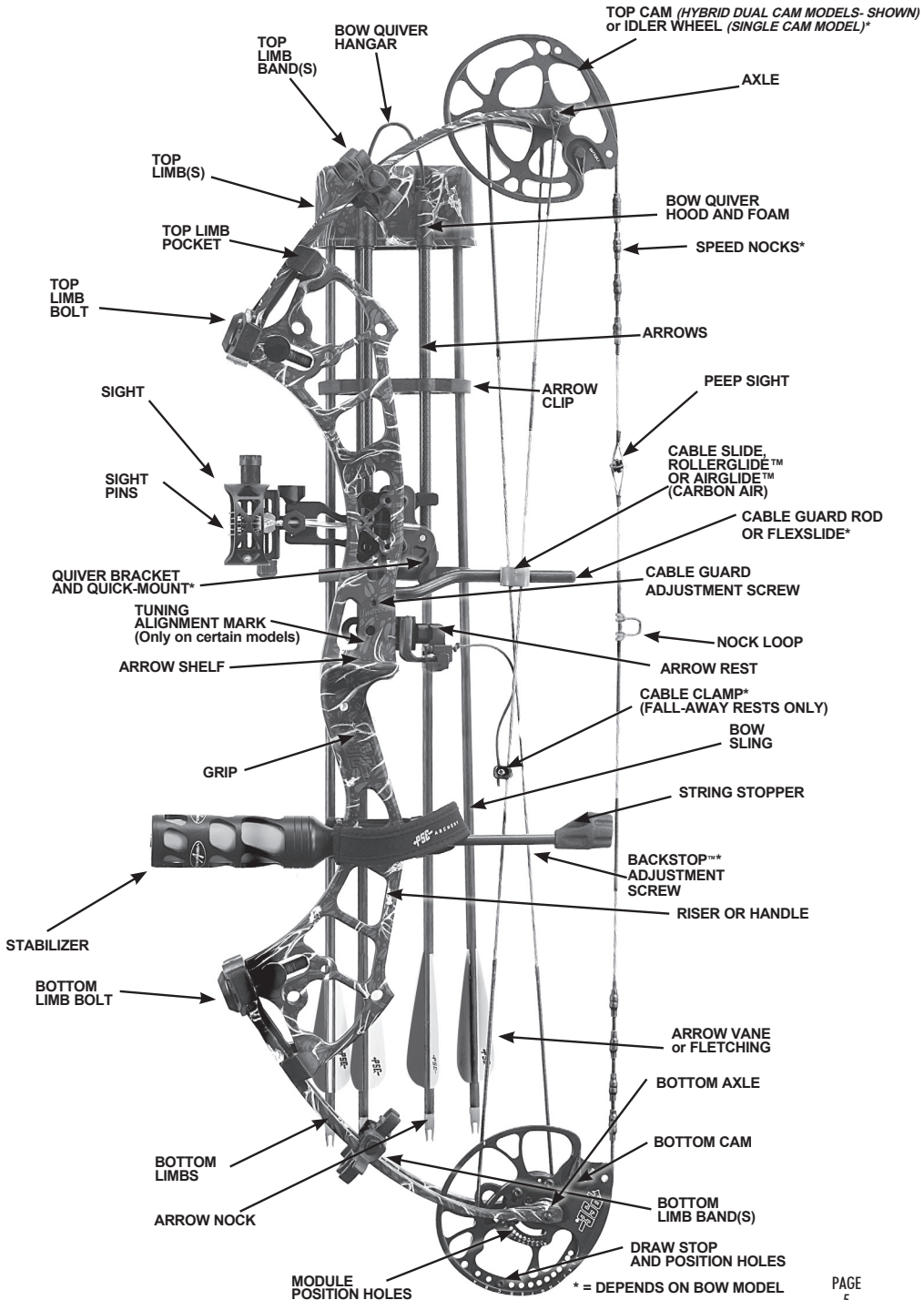

CABLE CONFIGURATIONS

ONE CAM BOW

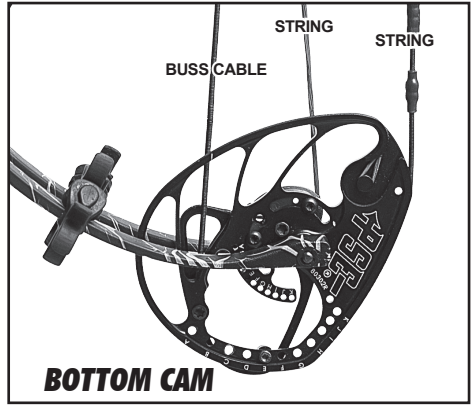
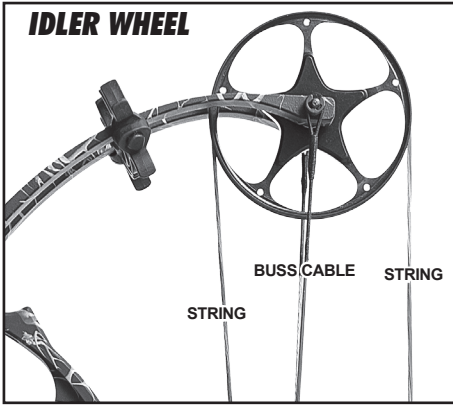

HYBRID CAM BOW

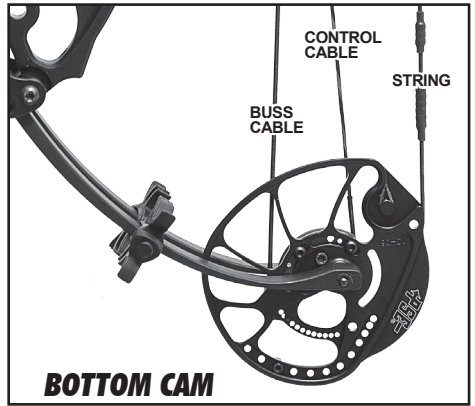
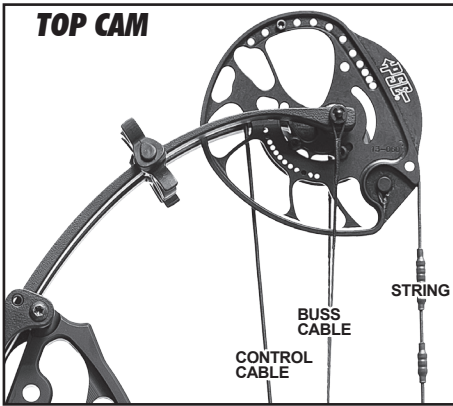

TWO CAM BOW

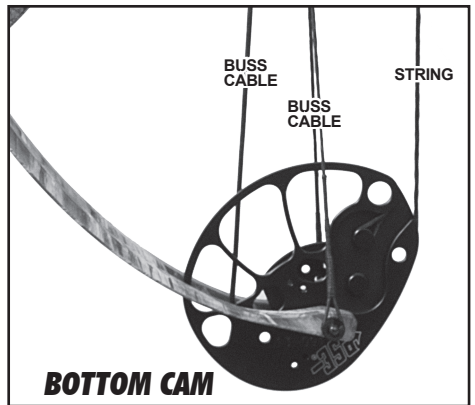
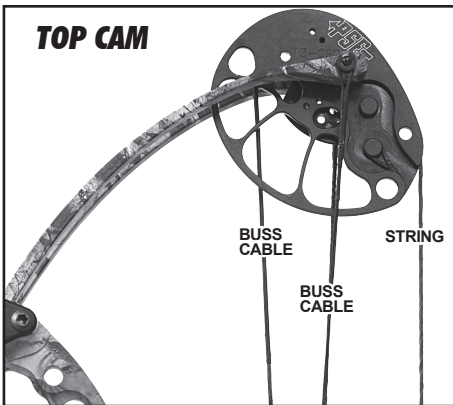

PSE X TECHNOLOGY

PSE X Technology bows come with many unique features that will enhance your archery experience.

USING A BOW PRESS WITH X TECHNOLOGY BOWS

ALL PSE X Technology bows **MUST** be serviced in an approved bow press and require special consideration. Do not attempt to service these bows in any bow press without reviewing the procedures described herein.

Use of a non-approved bow press or improper use of an approved bow press WILL result in damage to the bow and possible personal injury. Damages incurred by improper use or maintenance will not be covered under the warranty. See the PSE website at www.pse-archery.com for a list of approved bow presses.

There are two basic types of approved presses available: compression-type and pull-type. (Pg8)

COMPRESSION-TYPE BOW PRESS: (PREFERRED)

This type of press pushes in a horizontal direction against the tips of the limbs. No other support for the bow is required.

When using a press of this type, back each limb bolt out the maximum number of turns indicated on your bow's hang tag. Position the bow in the press and crank press inward to apply a compression force against the limb tips as shown below.



COMPRESS ONLY FAR ENOUGH TO LOOSEN THE STRING AND CABLES. OVER COMPRESSING COULD BREAK THE LIMBS AND CAUSE PERSONAL INJURY.

ANY DAMAGES INCURRED FROM OVER-COMPRESSING WILL NOT BE COVERED UNDER WARRANTY.

COMPRESSION-TYPE BOW PRESS



X Technology continued on next page

PSE X TECHNOLOGY USING A BOW PRESS

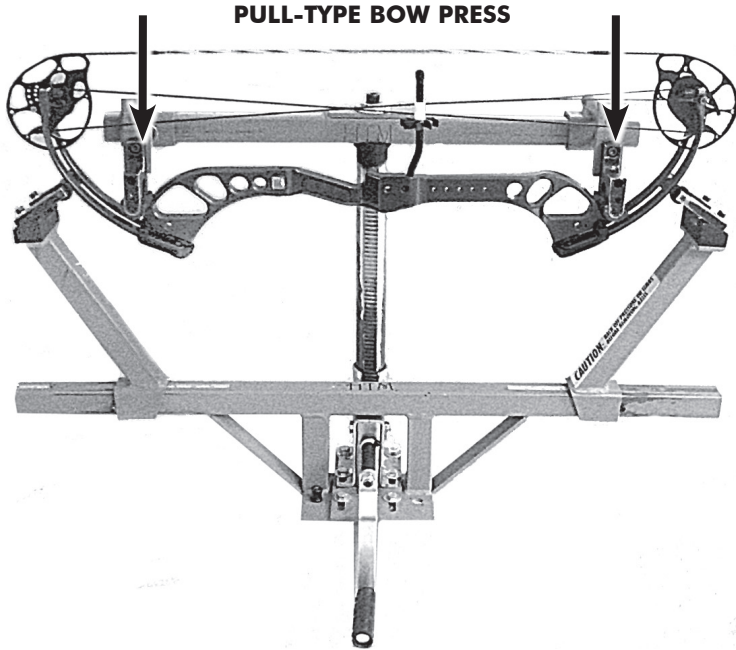

PULL-TYPE BOW PRESS:



This type of press pulls the riser of the bow in a vertical direction between rollers that compress the limbs.

When using this type press it is very important to position the rollers and pressure points correctly! See illustration above.

Back each limb bolt out the maximum number of turns indicated on your bow's hang tag and position the pressure points on the riser as close to the limbs as possible **WITHOUT** making contact with the limbs as shown in the photo below.

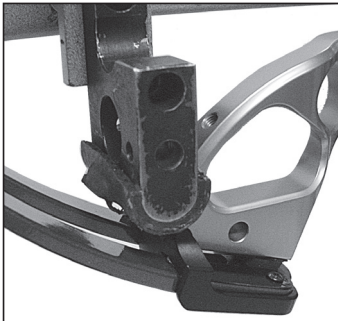

THE PRESSURE POINTS MUST NOT CONTACT THE LIMBS AT ANY TIME DURING SERVICING.

PULL-TYPE BOW PRESS

X Technology continued on next page

PSE X TECHNOLOGY USING A BOW PRESS (Continued)



Position the limb rollers outward on the limbs so that when the riser is pulled down the bow does not slip through/between the rollers before releasing tension on the string and cables. The rollers must be at least 4" from the limb pockets or the limbs will break. While placing tension on the limbs, **BE VERY CAREFUL NOT TO PULL THE RISER DOWN TOO FAR. DEFLECT THE LIMBS JUST ENOUGH TO REMOVE THE STRING AND CABLES.** Never allow the rollers to go past the end of the limb belly (thinnest part).

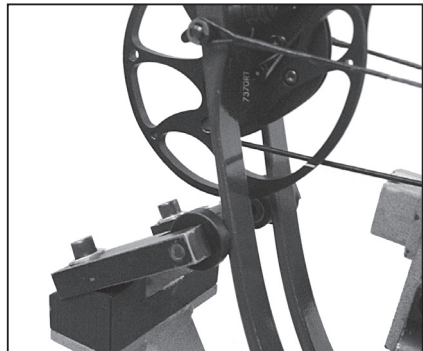
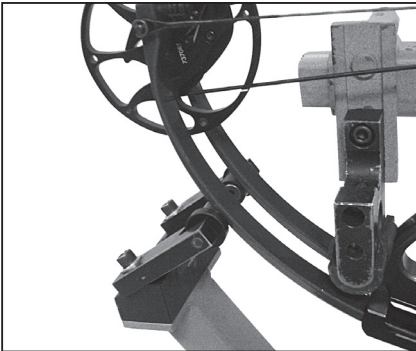

Service such as peep and string mounted vibration damper installation and string replacement can be performed with a "Pocket Press" portable bow press available from your local PSE dealer. These pocket presses are available for a variety of axle-to-axle lengths and cam types.



SERVICING BOWS WITH PSE FT CAMS (PSE FULL THROTTLE™) **CAUTION • CAUTION • CAUTION!**

When servicing bows with PSE FT cams, such as the Full Throttle™, it is important to use a bow press that has enough clearance for the cams.

On some bow presses the cams may make contact with the area shown in Figure 1 when compressing the limbs. Watch very carefully as the bow is compressed. If either cam comes in contact with the bow press, **STOP IMMEDIATELY or permanent damage to bow components may occur.**

Contact the bow press manufacturer for further information.

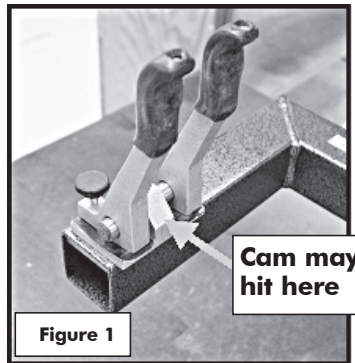

INSTALLATION OF ACCESSORIES

Arrowrest/Overdraw: The arrowrest or overdraw should be installed according to the instructions received with the product. It is usually mounted to the riser in the threaded hole on the side opposite the shelf (Hole "A") using the hardware provided with the arrowrest or overdraw.

Sight: The sight should be installed according to the instructions received with the product. It is usually mounted to the riser in the threaded holes (Holes "B") on the side opposite the shelf using the hardware provided with the sight. Some bows are equipped with multiple sight mounting holes which allow the sight to be moved up or down.

Stabilizer: The stabilizer should be mounted according to the manufacturer's recommendation. It is usually mounted in the threaded hole on the front of the riser (Hole "C").

Bow Sling: The bow sling attaches to the riser of the bow generally with the stabilizer. If a stabilizer is not used, attach the sling to the riser with the correct sized bolt (5/16" - 24) using the hole provided for the stabilizer (Hole "C").

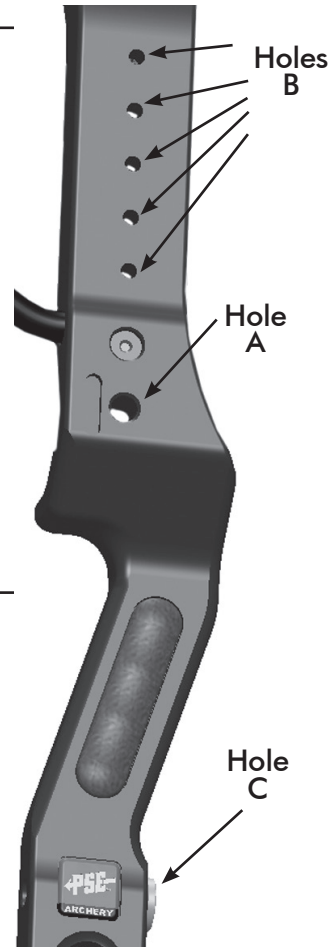

OTHER ADJUSTMENTS

Draw Weight: Your bow is factory-set to within 2 lbs. of the peak draw weight indicated on the bow hang tag and the last 2 digits of the serial number. Changes in draw weight can be made by turning the limb bolt in or out. Before making any changes in weight, turn the limb bolt clockwise to the bottom position. Never use extreme torque when turning the bolt or damage to the limb may occur. The limb bolt may then be turned counterclockwise to obtain the desired weight, but NEVER more than the number of turns indicated on the hang tag. Adjust each limb exactly the same. (See note and Fig. A below)

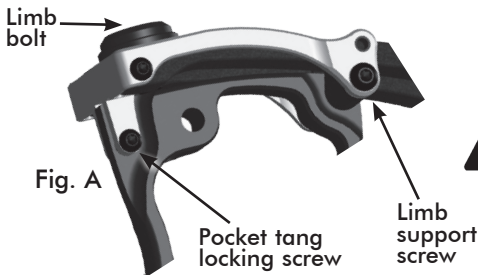

CAUTION: On some bow models, the limb bolt locking screw, limb support screws or pocket tang locking screw **MUST** be loosened **BEFORE** adjusting.

Your Authorized PSE Dealer is supplied with technical information on PSE bows and cams. Please see your Dealer for assistance when making these adjustments.

SETTING-UP YOUR BOW

NOCKING POINT PLACEMENT:

Finger shooters: Install the nocking point so that the arrow passes the center of the arrow rest mounting hole and runs slightly point-down relative to the tuning mark on the window of the bow.

Release Aid shooters: Install the nocking point so that the arrow passes the center of the arrow rest mounting hole and runs parallel to the alignment mark on the window of the bow.

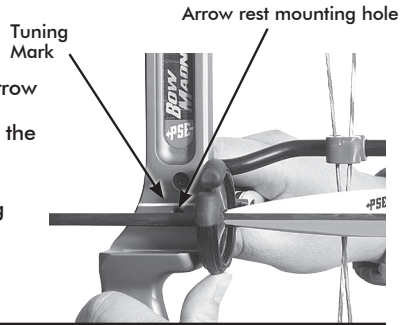

ARROW REST ADJUSTMENT:

When shooting with a release aid, the in/out position of the arrow rest should be adjusted so that the arrow runs parallel with the tuning mark on the shelf when viewed from above. When shooting with fingers the arrow should point slightly outside the tuning alignment mark on the shelf.

NOTE: Tuning alignment marks are for reference only. Adjustments will likely be necessary to nocking point and in/out position during tuning

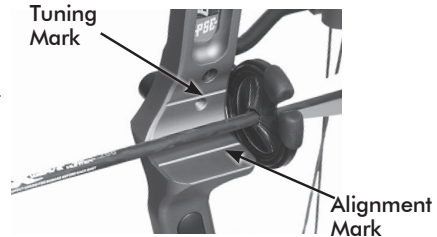

SIGHT ADJUSTMENT:

When adjusting the sight pin locations, always remember to "follow the group". That is, if the shot group is to the left of the target, move the sight pins to the left. If the shot group is low, move the sight pins down.

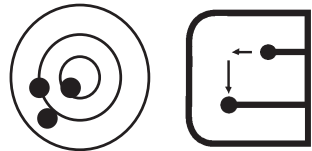

CABLE GUARD ADJUSTMENT AND INSTALLATION-

Install the cable guard as shown in Figure A. Adjust the cable guard so the cables just clear the arrow vanes. On bows using an offset cable guard rod, adjustments must be done with the rod in the up position (2 o'clock) as shown in Figure B (10 o'clock for left handed bows).

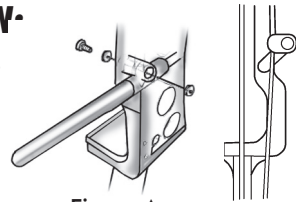
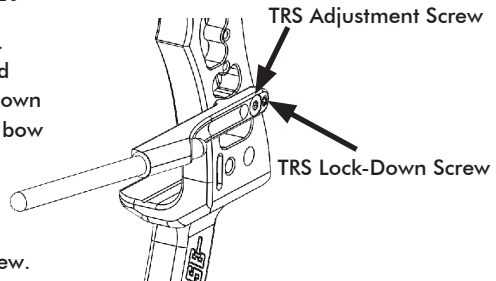

Figure A

TRS CABLE GUARD INSTALLATION:

Install TRS (Torque Reduction System) as shown. Tighten or loosen adjustment screw until desired cable clearance is obtained. Tighten the Lock-Down Screw to lock into place. (TRS will only work on bow risers equipped with the machined in Flex-Slide feature.)

To Adjust: Loosen Lock-Down screw, Turn Adjustment screw, the retighten Lock-Down Screw.



FLEXSLIDE 2™ ADJUSTMENT & INSTALL

The PSE FlexSlide 2™ cable guard system is based on the same advanced design used to create PSE Limbs. The flex-tuned design and adjustable offset are engineered to create more consistent lateral loads through the draw cycle and improve bow accuracy.

1. The standard factory setting adjusts the FlexSlide 2™ to its bottom position for maximum arrow clearance.
2. To adjust the lateral position, turn the adjustment screw counterclockwise to reduce arrow clearance or clockwise to increase arrow clearance.
3. After making adjustments to your FlexSlide 2™, check both arrow clearance and BackStop™ clearance. When drawing the bow, the buss cable should never contact the arrow shaft or any part of the Backstop™.
4. If any contact exists, tighten the adjustment screw to create adequate clearance. One full turn on the adjustment screw will move the slide approximately 1/8". Only tighten until the section of the FlexSlide 2™ under the screw head touches the riser.

DO NOT OVERTIGHTEN.

NOTE: Lateral adjustments to the FlexSlide 2™ may affect arrow tuning.



ONLY ON
PSE
PRO
SERIES

BACKSTOP™ INSTRUCTIONS

Note: Some PSE Pro Series and Mainline bow models come from the factory with the Backstop™ 4 or Backstop™ 3 installed. These instructions refer to reinstallation or adjustment if needed after making adjustments

1. Install the Backstop™ 4 or Backstop™ 3 into the threaded hole below the grip on the string-facing side of the bow.
2. Adjust the rotator until it makes contact with the string. Mark the string 1/4" above and 1/4" below where it makes contact with the string. Remove Backstop™ and add serving to that area of the string if it does not already exist. Reinstall the Backstop™.
3. Securely tighten the base to the bow handle using the cross-drilled hole.
4. Adjust the Backstop™ 4 or Backstop™ 3 by rotating and sliding in and out to the desired position. Tighten the rotator screw. The Backstop™ 4 and Backstop™ 3 designs allows for the bumper to be positioned so the string strikes the center of the bumper. It is desired to have some clearance (approximately 1/16") between the bumper and the bowstring at brace. Once alignment is set, add a small drop of instant glue to lock orientation.

← Lateral Adjustments →

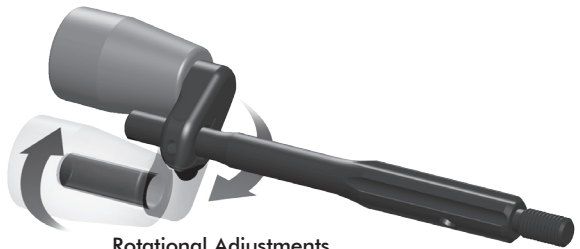
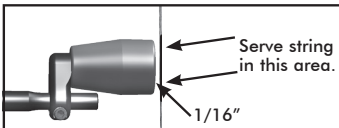

Rotational Adjustments

BACKSTOP™ 4 INSTRUCTIONS (CONT.)



Backstop™ 4

Note: The Backstop 4 adjusts like the Backstop 3 but is enhanced with a grooved rubber string stop to better stop the string.

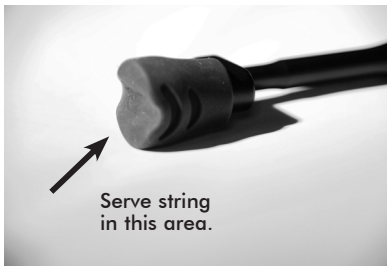

Serve string
in this area.



Rotational Adjustments

STING STOP™ INSTRUCTIONS

Note: Several PSE bow models come from the factory with the PSE Sting Stop™ Backstop installed. These instructions refer to reinstallation or adjustment if needed after making adjustments to your PSE bow.

1. Thread the Sting Stop™ nut all the way up toward the bumper of the Sting Stop™ rod.
2. Thread the Sting Stop™ rod into the threaded hole below the grip on the riser. The bowstring will need to be displaced slightly to one side to thread the rod into the bow.
3. Unscrew the Sting Stop™ until the rubber bumper approaches the bowstring. Mark the string 1/4" above the rubber bumper in its highest position and 1/4" below the bumper in its lowest position. Remove the Sting Stop™ and add serving to the marked area of the string if it does not already exist. Reinstall the Sting Stop™.

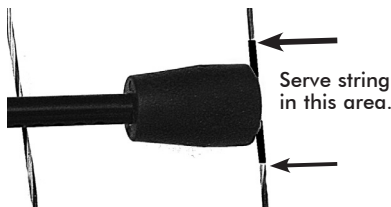

Serve string
in this area.

4. Adjust the Sting Stop™ to the desired position and tighten the Sting Stop™ nut against the riser. The Sting Stop™ design allows for the bumper to be positioned so the string strikes the center of the bumper. It is desired to have some clearance (approximately 1/16") between the bumper and the bowstring at brace. It is preferred to have the Sting Stop™ rod in the up position if possible, but may not be possible in order to achieve the necessary clearance and contact point.

INSTALLING SHOCK MODZ™ LIMB DAMPERS

Shock-Modz can be installed in four (4) different orientations between the top and bottom split limbs.

Into first limb channel and then flex the Shock-Modz to align into the opposit channel.

Be sure to position the Shock-Modz at least 1/2" away from the cam.



INSTALLING LIMB BAND DAMPER

If your split limb bow is equipped with limb bands, the proper placement of the bands is at least 1/2" away from the cam.



Limb Band Damper

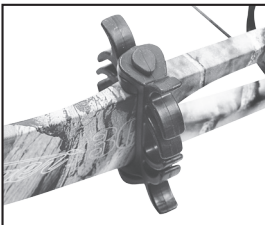

Limb Band on Solid Limb



Limb Bands across Split Limb



Limb Bands on Split Limb (one per limb)

PSE ASYMMETRIC IDLER

PSE single cam bows are equipped with a special asymmetric idler wheel, which is assembled on the top limbs. It is essential that the idler be oriented properly.

The wide edge of the idler always goes to the cable guard side of the bow.

The illustration shows the proper orientation of the idler for a right-handed bow when viewed while holding the bow as it is shot.

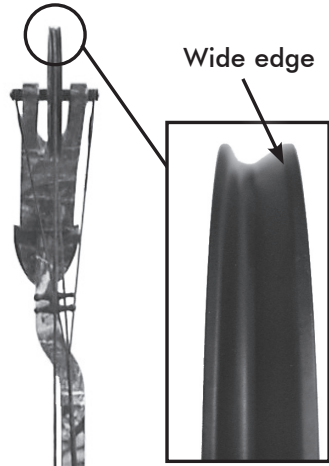

THE PSE WEBSITE IS YOUR RESOURCE FOR EVERYTHING WE HAVE TO OFFER!

PSE Evolve
\$949.99

HANDEDNESS:

DRAW WEIGHT:

COLOR:

SKILL N/A
Categories: Evolve Cam (EC) Bow, Pro Series Compound Bow

PRODUCT DESCRIPTION
Evolve your hunt with the 2017 PSE Evolve®! Engineered from the ground up to be the most comfortable hunting bow we've ever made, we started with our amazing new EVOLVE Cam System (ECS), which gives this hunting bow an unbelievable 70% let-off and the smoothest shot on the market.

But PSE wasn't done yet... we paired the ECS with our all-new ultra stiff forged new design for amazing rigidity and shot stability, our Wide Track Limb System and Wings Lock™ Speed Power for flexible adjusting and 360° of shooting power, and teamed all of that with our new RipStop® cable guard system to eliminate friction. We also added touch-in our stabilization points to deliver a bow that is pure shooting nirvana!

SPECIFICATIONS

Axle-to-Axle	30.5 (30.5")
Draw Height	6.5 (6")
Handedness	L/R, Right
Axle to Axle	30"
Let-off	67%-81%
Draw Length	29"
Draw Length Range	24.5 (24.5") to 30"
Draw Weight	70# (65#)
Mass Weight	4.3 lbs.

Max. 1 inch Bolt Torque: 10

www.pse-archery.com

WEDGE LOCK POCKET LAS (LATERAL ADJUSTMENT SYSTEM) FOR XPRESSION, XPRESSION 3D, SUPRA EXT & BEAST EXT

The LAS utilizes pull-system based tuning adjustments. To adjust it, simply loosen the drive screw on one side of the riser and tighten the drive screw on the other side of the riser to move the limb bolt.

When paper tuning your bow and adjusting it for a left or right paper tear, move the LAS in the same direction that you would move your arrow rest if you were adjusting that.

TO TUNE OUT A LEFT TEAR, ADJUST THE LAS TO THE RIGHT. TO TUNE OUT A RIGHT TEAR, ADJUST THE LAS TO THE LEFT.

To move your tear to to the right, loosen the left drive screw as seen in **FIGURE 1**, and then tighten the right drive screw as seen in **FIGURE 2**. Continue to adjust until your paper tuning results in a clean "bullet hole" without left or right tears. To move your tear to the left, reverse the process by loosening the right drive screw and tightening the left drive screw.

NOTE: The LAS system can be used in conjunction with yoke tuning and arrow rest tuning as the shooter sees fit. Also, one or both Wedge Lock Pockets can be adjusted at a time. Adjusting one pocket at a time allows for finer tuning, while adjusting both at the same time will allow for larger changes.

FIGURE 1:

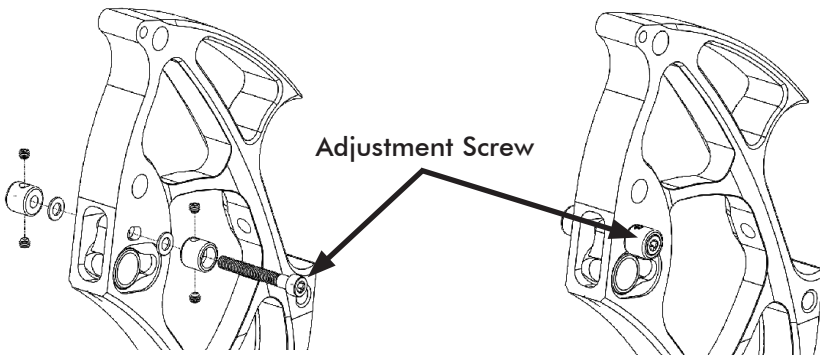

FIGURE 2:



MICRO-LAS (SINGLE SCREW ADJUSTMENTS)

Install microLAS (Lateral Adjustment System) as shown. Make sure all set screws are locked down tight. When finished, the adjustment screw should not turn too freely or be too tight. When installed correctly, it should take a bit of resistance to turn the screw in either direction with no play in the system. To Adjust: Turn Adjustment Screw clockwise/counter-clockwise to adjust lateral position of the pocket to help with left/right bow tuning.



ECS CAM ADJUSTMENTS

To change draw length on the ECS: Loosen the two 8-32 size 15 Torx screws holding the Module to the Cam approximately 1 ½ turns, move the module to the desired setting. The setting will be in the window marked "DL" Move the Module to the same setting on both top and bottom Cams.

To change Let-off and the ECS: Loosen the 4-40 size 10 Torx screw holding the Stop on the Module approximately 1 ½ turns and slide to the desired position. Move the Stop to the same setting on both top and bottom Modules. There are 3 settings, each corresponds to a change in Let-off of 5%. The standard Module Let-off options are 80,85 and 90%. An aftermarket low let-off Module is available with let off settings of 65.70 and 75%.

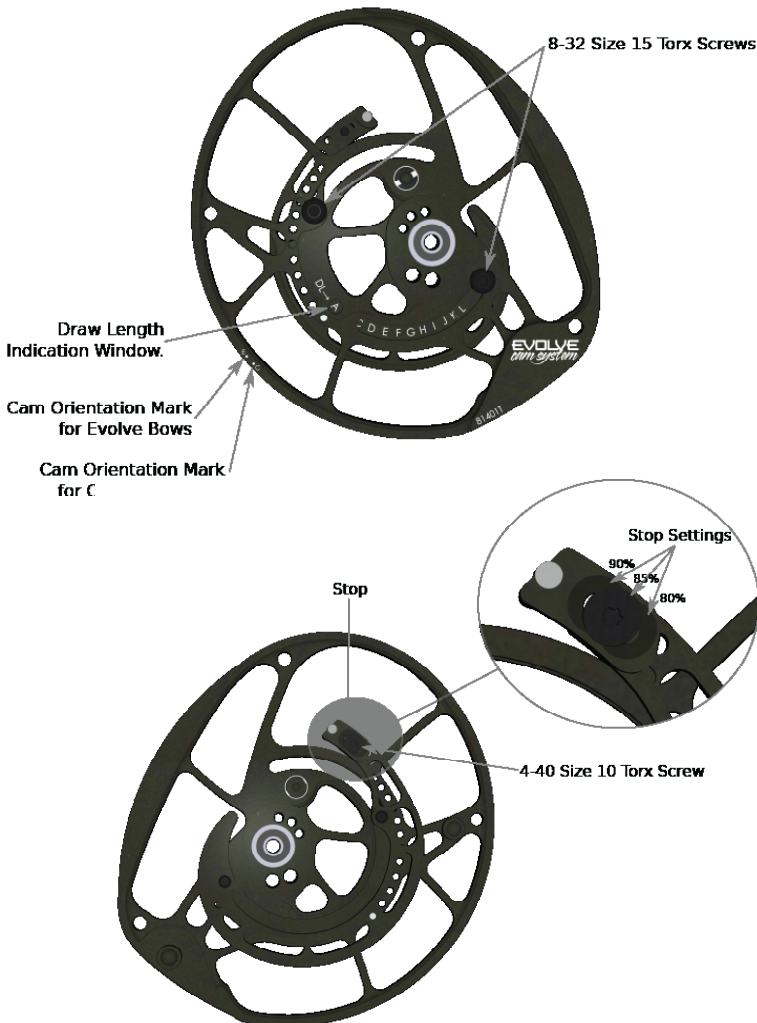

CAM ADJUSTMENTS

WHEELS/CAMS: Many PSE wheels and cams have adjustable features. Each one comes from the factory set up and ready to use but there may be occasions that you need to adjust the characteristics of your bow. In some cases you will need a PSE Tune Chart to determine what to adjust, and you may need to see a PSE Dealer for information. If you are not sure of the adjustment you are making, stop and see your PSE Dealer for assistance. In some cases, an appropriate bow press will be needed to make adjustments to cams and wheels. If you do not have an appropriate press, see your PSE Dealer.

CAM ORIENTATION:

On cams with orientation marks, a reference mark is found to indicate an approximate orientation. This line is for reference only is meant to give approximate orientation only and may vary between bow models. The orientation of the cams may be changed slightly by twisting or untwisting the string or cables.

ALL INNER-CAMS:

The inner-cam system allows draw length adjustments over a prescribed range usually without putting the bow in a bow press. There are two types of inner-cam systems: discrete setting inner-cams and Posi-Lock inner-cams.

Discrete setting inner-cams have the adjustment screws going through a specific hole in the inner-cam and threading into the cam. The screws need to be completely removed to make adjustments. The "A" setting is the longest draw length for that bow and draw lengths get shorter as you progress through the alphabet (A to B, B to C, etc.)

Posi-lock adjustable inner-cams are adjustable in $\frac{1}{2}$ " draw length increments. The "A" setting is the longest setting for the cam. Draw lengths get shorter as you progress through the alphabet ("A" to "B", "B" to "C", etc.) by roughly $\frac{1}{2}$ " per letter.

Second and third generation Posi-lock inner-cams allow for draw length adjustments in $\frac{1}{2}$ " increments without changing inner-cams. To adjust draw length, loosen the two 8-32 button head screws two full turns. This will allow the inner-cam to be lifted far enough to disengage the positioning pin and allow the inner-cam to rotate to a new position. Some cams may require the 8-32 button head screws to move to alternate locations to reach the new draw length adjustment position. Some draw length adjustment positions may not be accessible without putting the bow in a bow press. When the new draw length adjustment position has been achieved with the inner-cam, tighten the two 8-32 button head screws and move the draw stop to the matching setting ("A" and "A", "B" and "B").

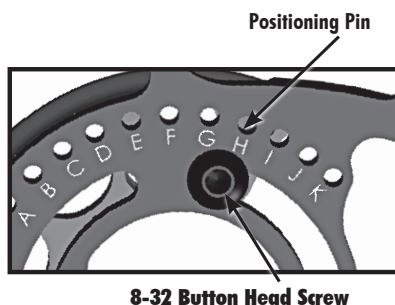

In cases where there is an inner-cam on both the top and bottom cam, both cams must be set in the same letter position for the bow to tune and shoot properly. In cases where there is a separate draw stop, the draw stop must be moved to the hole marked with the letter corresponding to the inner-cam setting.

INFORMATION ON DRAW STOP ADJUSTMENTS:

The position of the draw stop must match the setting on the inner-cam. For example, if the cam is set on "E", the draw stop must be placed in one of the draw stop holes marked with an "E". If the inner-cam is in the "B" setting, the stop must be in the "B" position. Certain hybrid cams have top and bottom stops. They can be shot with both stops for a harder "wall" or with only the top stop for a softer "wall". Never shoot hybrid cams with the two stop option with only the bottom stop. In either case, the stops need to be in the holes marked with the same marking as the inner-cam setting.

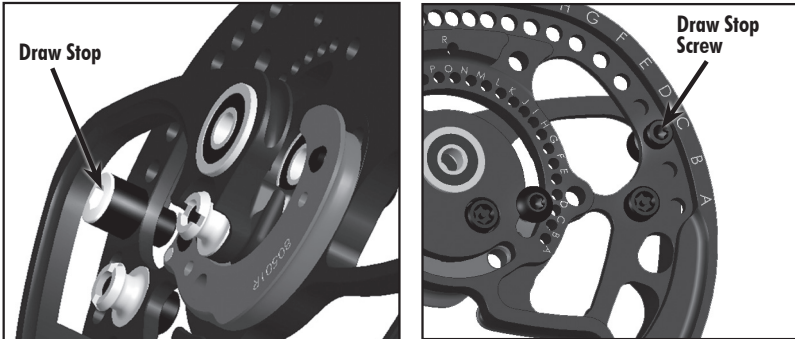

LIMB STOP ADJUSTMENTS

On bows equipped with a limb stop and cable stop, use of the limb stop is optional. If choosing not to use the limb stop it may be removed or set in the longest "A" position so that it does not contact the limb before the cable stop. Engraving for limb stop positions is approximate and for reference only. Many factors will cause changes to the optimum limb stop position.

OPTION 1: (If a safe method of holding the bow at full draw is available, such as a draw board) Set Limb Stop to the Longest "A" Location and time bow to cable stops at desired draw length as shown in Figure 1. Using a safe method to hold the bow at full draw adjust limb stop so it contacts the limb as shown in Figure 2.

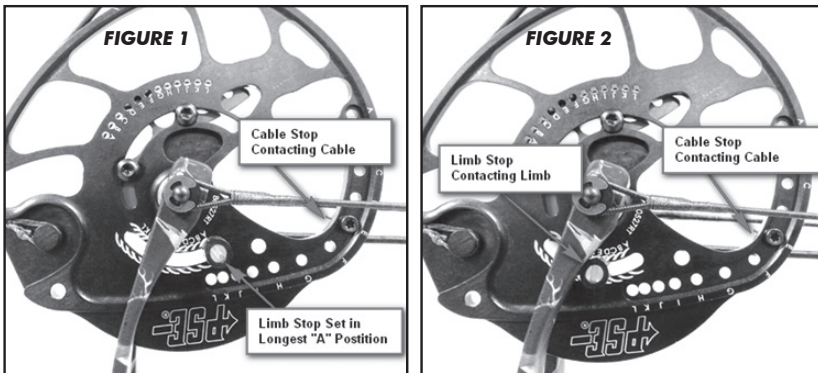

OPTION 2: Set Limb Stop to the Longest "A" Position. Time bow to cable stops at desired draw length. Set Limb Stop to the corresponding stop position. Draw bow with an arrow, pointed at a safe range or target and observe whether the cable stop or Limb Stop contacts first. Make small adjustments to the Limb Stop position and recheck until it contacts at the same time as the cable stop.

PSE PRO SERIES BOWS: DRAW SETTING CHART

NOTE: The PSE Full Throttle has cam-specific draw lengths from 26-1/2" to 30" in 1/2" increments.

SETTING	CARBON AIR 34	CARBON AIR 32 HL	CARBON AIR 32 HD	FULL THROTTLE	EVOLVE 35	EVOLVE	DECREE 32
A	31 1/2	30	30 1/2	NA	31 1/2	30	30 1/2
B	31	29 1/2	30	NA	31	29 1/2	30
C	30 1/2	29	29 1/2	NA	30 1/2	29	29 1/2
D	30	28 1/2	29	NA	30	28 1/2	29
E	29 1/2	28	28 1/2	NA	29 1/2	28	28 1/2
F	29	27 1/2	28	NA	29	27 1/2	28
G	28 1/2	27	27 1/2	NA	28 1/2	27	27 1/2
H	28	26 1/2	27	NA	28	26 1/2	27
I	27 1/2	26	26 1/2	NA	27 1/2	26	26 1/2
J	27	25 1/2	26	NA	27	25 1/2	26
K	26 1/2	25	25 1/2	NA	26 1/2	25	25 1/2
L	26	24 1/2	25	NA	26	24 1/2	25
M	-	-	24 1/2	NA	-	-	24 1/2

SETTING	DECREE 35	BEAST EXT	INERTIA	DRIVE R DC	DRIVE R SD	VENDETTA VX
A	31 1/2	33	30	30 1/2	28	30 1/2
B	31	32 1/2	29 1/2	30	27 1/2	30
C	30 1/2	32	29	29 1/2	27	29 1/2
D	30	31 1/2	28 1/2	29	26 3/8	29
E	29 1/2	31	28	28 1/2	26 1/8	28 1/2
F	29	30 1/2	27 1/2	28	25 3/4	28
G	28 1/2	30	27	27 1/2	25 1/4	27 1/2
H	28	29 1/2	26 1/2	27	24 3/4	27
I	27 1/2	29	26	26 1/2	24 3/8	26 1/2
J	27	28 1/2	25 1/2	26	24	26
K	26 1/2	28	25	25 1/2	23 1/2	25 1/2
L	26	-	24 1/2	25	23	24 1/2
M	25 1/2	-	-	-	-	-

SETTING	XPRESSION	XPRESSION 3D	SUPRA EXT	PHENOM SD
A	31 1/2	30 1/2	30 1/2	29
B	31	30	30	28 1/2
C	30 1/2	29 1/2	29 1/2	28
D	30	29	29	27 1/2
E	29 1/2	28 1/2	28 1/2	27
F	29	28	28	26 1/2
G	28 1/2	27 1/2	27 1/2	26
H	28	27	27	25 1/2
I	27 1/2	26 1/2	26 1/2	25
J	27	26	26	24 1/2
K	26 1/2	25 1/2	25 1/2	24
L	26	25	25	23 1/2

PSE MAIN LINE BOWS: DRAW SETTING CHART

PSE Mainline bows with highly adjustable cams continued on page 22

SETTING	BOWMADNESS EPIX	BRUTE FORCE LT	INFINITY	PHENOM XT
A	30	31	30 1/2	33
B	29 1/2	30 1/2	30	32 1/2
C	29	30	29 1/2	32
D	28 1/2	29 1/2	29	31 1/2
E	28	29	28 1/2	31
F	27 1/2	28 1/2	28	30 1/2
G	27	28	27 1/2	30
H	26 1/2	27 1/2	27	29 1/2
I	26	27	26 1/2	29
J	25 1/2	26 1/2	26	28 1/2
K	25	26	25 1/2	28
L	24 1/2	25 1/2	25	27 1/2
M	24	25	24 1/2	-

PSE HIGHLY ADJUSTABLE CAM INFORMATION

The following pages of information apply to the following PSE models:

- **PSE STINGER™ X**
- **PSE FEVER™**
- **PSE MINI BURNER™ XT**

PSE SX CAM INFORMATION

BOWS: PSE STINGER™ X

ADJUSTING THE SX CAM:

Select the "PERFORMANCE" or "GROW WITH YOU" cable position based on the desired draw characteristics and peak weight range.

Rotate the inner-cam position (A thru P) to match the desired draw length. To adjust, loosen each #8-32 button head screw approx. 2 full turns. Rotate into position and tighten screws. NOTE: the 3rd tapped hole position in the inner-cam may be used if the screw becomes hidden behind the limb.



"Performance" Setting



"Grow With You" Setting

PSE STINGER™ X

**INCLUDES
STINGER™ X STILETTO™**

SX™ CAM DRAW SETTING CHARTS



PSE STINGER X- 70# PERFORMANCE CABLE SETTINGS

Inner Cam Stop Setting	Draw Length Setting	Draw Weight at Bottom	Draw Weight 13 Turns Off
A	30	70	47
B	29½	70	47
C	29	70	47
D	28½	70	47
E	28	70	47
F	28	70	47
G	27	70	47
H	26½	70	47
I	26	70	47
J	25½	70	47
K	25	70	47
L	24½	70	47
M	24	70	47
N	23½	70	47
O	23	70	47
P	22½	70	47

PSE STINGER X- 70# GROW WITH YOU CABLE SETTINGS

Inner Cam Stop Setting	Draw Length Setting	Draw Weight at Bottom	Draw Weight 13 Turns Off
A	29½	63½	42¼
B	29	63	42
C	28½	62½	41¾
D	28	61¾	41¼
E	27½	61¼	40¾
F	27	60¾	40½
G	26½	60	40¼
H	26	59½	39¾
I	25½	59	39½
J	24¾	58	38½
K	24¼	57¼	38¼
L	23¾	56	37¼
M	23	54¼	36¼
N	22¾	52½	35
O	21¾	50¼	33¼
P	21	47¾	31½

PSE STINGER X- 60# PERFORMANCE CABLE SETTINGS

Inner Cam Stop Setting	Draw Length Setting	Draw Weight at Bottom	Draw Weight 13 Turns Off
A	30	60	40
B	29½	60	40
C	29	60	40
D	28½	60	40
E	28	60	40
F	28	60	40
G	27	60	40
H	26½	60	40
I	26	60	40
J	25½	60	40
K	25	60	40
L	24½	60	40
M	24	60	40
N	23½	60	40
O	23	60	40
P	22½	60	40

PSE STINGER X- 60# GROW WITH YOU CABLE SETTINGS

Inner Cam Stop Setting	Draw Length Setting	Draw Weight at Bottom	Draw Weight 13 Turns Off
A	29½	54½	36¼
B	29	54	36
C	28½	53½	35¾
D	28	53	35¼
E	27½	52½	35
F	27	52	34¾
G	26½	51½	34½
H	26	51	34
I	25½	50½	33¾
J	24¾	49¾	33
K	24¼	49	32¾
L	23¾	48	32
M	23	46½	31
N	22¾	45	30
O	21¾	43	28½
P	21	41	27

**PSE STINGER X- 50#
PERFORMANCE
CABLE SETTINGS**

Inner Cam Stop Setting	Draw Length Setting	Draw Weight at Bottom	Draw Weight 13 Turns Off
A	30	50	33
B	29½	50	33
C	29	50	33
D	28½	50	33
E	28	50	33
F	28	50	33
G	27	50	33
H	26½	50	33
I	26	50	33
J	25½	50	33
K	25	50	33
L	24½	50	33
M	24	50	33
N	23½	50	33
O	23	50	33
P	22½	50	3

**PSE STINGER X- 50#
GROW WITH YOU
CABLE SETTINGS**

Inner Cam Stop Setting	Draw Length Setting	Draw Weight at Bottom	Draw Weight 13 Turns Off
A	29½	45½	30¼
B	29	45	30
C	28½	44½	29¾
D	28	44¼	29½
E	27½	43¾	29¼
F	27	43¼	29
G	26½	43	28¾
H	26	42½	28¼
I	25½	42	28¼
J	24¾	41½	27½
K	24¼	40¾	27¼
L	23 5/8	40	26¾
M	23	38¾	25¾
N	22¾	37½	25
O	21¾	35¾	23¾
P	21	34¼	22½

**PSE STINGER X- 40#
PERFORMANCE
CABLE SETTINGS**

Inner Cam Stop Setting	Draw Length Setting	Draw Weight at Bottom	Draw Weight 13 Turns Off
A	30	40	27
B	29½	40	27
C	29	40	27
D	28½	40	27
E	28	40	27
F	28	40	27
G	27	40	27
H	26½	40	27
I	26	40	27
J	25½	40	27
K	25	40	27
L	24½	40	27
M	24	40	27
N	23½	40	27
O	23	40	27
P	22½	40	27

**PSE STINGER X- 40#
GROW WITH YOU
CABLE SETTINGS**

Inner Cam Stop Setting	Draw Length Setting	Draw Weight at Bottom	Draw Weight 13 Turns Off
A	29½	36½	24¼
B	29	36	24
C	28½	35½	23¾
D	28	35½	23½
E	27½	35	23½
F	27	34½	23¼
G	26½	34½	23
H	26	34	22½
I	25½	33½	22½
J	24¾	33¼	22
K	24¼	32½	21¾
L	23¾	32	21½
M	23	31	20½
N	22¾	30	20
O	21¾	28½	19
P	21	27½	18



PSE VISION™ CAM INFORMATION

BOWS: PSE FEVER™ AND PSE MINI BURNER™ XT

ADJUSTING THE VISION™ CAM:

DRAW LENGTH:

STRING POST ADJUSTMENTS

PSE Vision cams have a string post adjustment for draw length as well as inner cam adjustments and “Flexible Cam” adjustments. To make a string post adjustment, compress the bow in a suitable bow press and relieve tension from the string and cables. See the draw length adjustment chart for your bow for details.

Select the draw length and the “PERFORMANCE” or “GROW WITH YOU” cable position based on the desired draw characteristics and peak weight range. If your desired draw length lies in the short post category, an approved bow press will be required to make this adjustment. Once the string is positioned onto the string posts of your choice, adjust the inner-cam to the desired location.

The inner-cam has holes marked “A” through “J” for adjusting draw length as well as a set of threaded holes marked “S” and “L”. The “L” holes are used for longer draw lengths and the “S” holes are used for shorter draw lengths. See the following tables for the setting required to achieve different draw lengths and weight for bows using this cam.

To make the necessary adjustment, remove the screw holding the inner-cam in place and rotate the inner-cam so the letter setting desired lines up with the threaded “L” or “S” hole in the cam. **IT IS IMPORTANT THAT BOTH TOP AND BOTTOM CAMS BE ADJUSTED THE SAME.** These adjustments can be made either with or without a bow press.

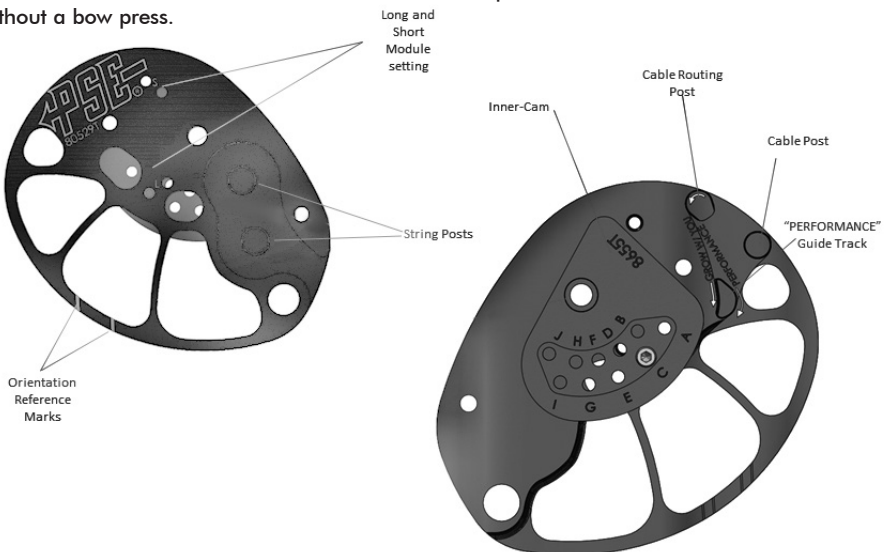

PSE FEVER™: PERFORMANCE DRAW SETTINGS

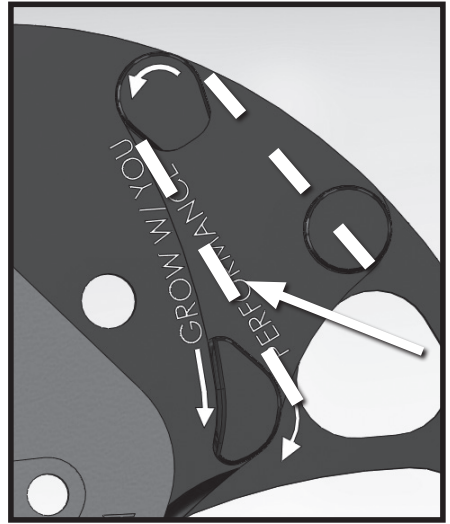

**PSE FEVER 60# PERFORMANCE
CABLE SETTINGS-LONG POST**

Inner Cam Stop Setting	Draw Length Setting	Draw Weight at Bottom	Draw Weight 13 Turns Off
A-L	29"	60	40
B-L	28¾"	60	40
C-L	27½"	60	40
D-L	27"	60	40
E-L	25¾"	60	40
F-L	25¼"	60	40
G-L	24¼"	60	40
H-L	24"	60	40
I-L	22½"	60	40
J-L	21¾"	60	40
A-S	21¼"	60	40
B-S	20"	60	40
C-S	19¼"	60	40
D-S	18½"	60	40
E-S	18"	60	40
F-S	17¾"	60	40
G-S	17½"	60	40
H-S	17¼"	60	40
I-S	17¼"	60	40
J-S	17"	60	40

**PSE FEVER 60# PERFORMANCE
CABLE SETTINGS-SHORT POST**

Inner Cam Stop Setting	Draw Length Setting	Draw Weight at Bottom	Draw Weight 13 Turns Off
A-L	28"	52	36
B-L	27½"	52	36
C-L	26½"	52	36
D-L	26"	52	36
E-L	24¾"	52	36
F-L	24½"	52	36
G-L	23"	52	36
H-L	22½"	52	35
I-L	21¼"	48	33
J-L	20¼"	48	31
A-S	19¾"	47	31
B-S	18½"	47	31
C-S	18"	47	31
D-S	17"	47	31
E-S	16½"	47	31
F-S	16¼"	47	31
G-S	16"	47	31
H-S	16"	47	31
I-S	15¾"	47	31
J-S	15½"	47	31

**PSE FEVER 50# PERFORMANCE
CABLE SETTINGS-LONG POST**

Inner Cam Stop Setting	Draw Length Setting	Draw Weight at Bottom	Draw Weight 13 Turns Off
A-L	29"	50	33
B-L	28 ³ / ₄ "	50	33
C-L	27 ¹ / ₂ "	50	33
D-L	27"	50	33
E-L	25 ³ / ₄ "	50	33
F-L	25 ¹ / ₄ "	50	33
G-L	24 ¹ / ₄ "	50	33
H-L	24"	50	33
I-L	22 ¹ / ₂ "	50	33
J-L	21 ³ / ₄ "	50	33
A-S	21 ¹ / ₄ "	50	33
B-S	20"	50	33
C-S	19 ¹ / ₄ "	50	33
D-S	18 ¹ / ₂ "	50	33
E-S	18"	50	33
F-S	17 ³ / ₄ "	50	33
G-S	17 ¹ / ₂ "	50	33
H-S	17 ¹ / ₄ "	50	33
I-S	17 ¹ / ₄ "	50	33
J-S	17"	50	33

**PSE FEVER 50# PERFORMANCE
CABLE SETTINGS-SHORT POST**

Inner Cam Stop Setting	Draw Length Setting	Draw Weight at Bottom	Draw Weight 13 Turns Off
A-L	28"	43	30
B-L	27 ¹ / ₂ "	43	30
C-L	26 ¹ / ₂ "	43	30
D-L	26"	43	30
E-L	24 ³ / ₄ "	43	30
F-L	24 ¹ / ₂ "	43	30
G-L	23"	43	30
H-L	22 ¹ / ₂ "	43	29
I-L	21 ¹ / ₄ "	40	27
J-L	20 ³ / ₄ "	40	26
A-S	19 ³ / ₄ "	39	26
B-S	18 ¹ / ₂ "	39	26
C-S	18"	39	26
D-S	17"	39	26
E-S	16 ¹ / ₂ "	39	26
F-S	16 ¹ / ₄ "	39	26
G-S	16"	39	26
H-S	16"	39	26
I-S	15 ³ / ₄ "	39	26
J-S	15 ¹ / ₂ "	39	26

**PSE FEVER 40# PERFORMANCE
CABLE SETTINGS-LONG POST**

Inner Cam Stop Setting	Draw Length Setting	Draw Weight at Bottom	Draw Weight 13 Turns Off
A-L	29"	40	26
B-L	28 ³ / ₄ "	40	26
C-L	27 ¹ / ₂ "	40	26
D-L	27"	40	26
E-L	25 ³ / ₄ "	40	26
F-L	25 ¹ / ₄ "	40	26
G-L	24 ¹ / ₄ "	40	26
H-L	24"	40	26
I-L	22 ¹ / ₂ "	40	26
J-L	21 ³ / ₄ "	40	26
A-S	21 ¹ / ₄ "	40	26
B-S	20"	40	26
C-S	19 ¹ / ₄ "	40	26
D-S	18 ¹ / ₂ "	40	26
E-S	18"	40	26
F-S	17 ³ / ₄ "	40	26
G-S	17 ¹ / ₂ "	40	26
H-S	17 ¹ / ₄ "	40	26
I-S	17 ¹ / ₄ "	40	26
J-S	17"	40	26

**PSE FEVER 40# PERFORMANCE
CABLE SETTINGS-SHORT POST**

Inner Cam Stop Setting	Draw Length Setting	Draw Weight at Bottom	Draw Weight 13 Turns Off
A-L	28"	35	24
B-L	27 ¹ / ₂ "	35	24
C-L	26 ¹ / ₂ "	35	24
D-L	26"	35	24
E-L	24 ³ / ₄ "	35	24
F-L	24 ¹ / ₂ "	35	24
G-L	23"	35	24
H-L	22 ¹ / ₂ "	35	23
I-L	21 ¹ / ₄ "	32	22
J-L	20 ³ / ₄ "	32	21
A-S	19 ³ / ₄ "	31	21
B-S	18 ¹ / ₂ "	31	21
C-S	18"	31	21
D-S	17"	31	21
E-S	16 ¹ / ₂ "	31	21
F-S	16 ¹ / ₄ "	31	21
G-S	16"	31	21
H-S	16"	31	21
I-S	15 ³ / ₄ "	31	21
J-S	15 ¹ / ₂ "	31	21

**PSE FEVER 29# PERFORMANCE
CABLE SETTINGS-LONG POST**

Inner Cam Stop Setting	Draw Length Setting	Draw Weight at Bottom	Draw Weight 13 Turns Off
A-L	29"	29	19
B-L	28 ³ / ₄ "	29	19
C-L	27 ¹ / ₂ "	29	19
D-L	27"	29	19
E-L	25 ³ / ₄ "	29	19
F-L	25 ¹ / ₄ "	29	19
G-L	24 ¹ / ₄ "	29	19
H-L	24"	29	19
I-L	22 ¹ / ₂ "	29	19
J-L	21 ³ / ₄ "	29	19
A-S	21 ¹ / ₄ "	29	19
B-S	20"	29	19
C-S	19 ¹ / ₄ "	29	19
D-S	18 ¹ / ₂ "	29	19
E-S	18"	29	19
F-S	17 ³ / ₄ "	29	19
G-S	17 ¹ / ₂ "	29	19
H-S	17 ¹ / ₄ "	29	19
I-S	17 ¹ / ₄ "	29	19
J-S	17"	29	19

**PSE FEVER 29# PERFORMANCE
CABLE SETTINGS-SHORT POST**

Inner Cam Stop Setting	Draw Length Setting	Draw Weight at Bottom	Draw Weight 13 Turns Off
A-L	28"	25	18
B-L	27 ¹ / ₂ "	25	18
C-L	26 ¹ / ₂ "	25	18
D-L	26"	25	18
E-L	24 ³ / ₄ "	25	18
F-L	24 ¹ / ₂ "	25	18
G-L	23"	25	18
H-L	22 ¹ / ₂ "	25	17
I-L	21 ¹ / ₄ "	23	16
J-L	20 ³ / ₄ "	23	15
A-S	19 ³ / ₄ "	23	15
B-S	18 ¹ / ₂ "	23	15
C-S	18"	23	15
D-S	17"	23	15
E-S	16 ¹ / ₂ "	23	15
F-S	16 ¹ / ₄ "	23	15
G-S	16"	23	15
H-S	16"	23	15
I-S	15 ³ / ₄ "	23	15
J-S	15 ¹ / ₂ "	23	15

PSE FEVER™: GROW WITH YOU DRAW SETTINGS

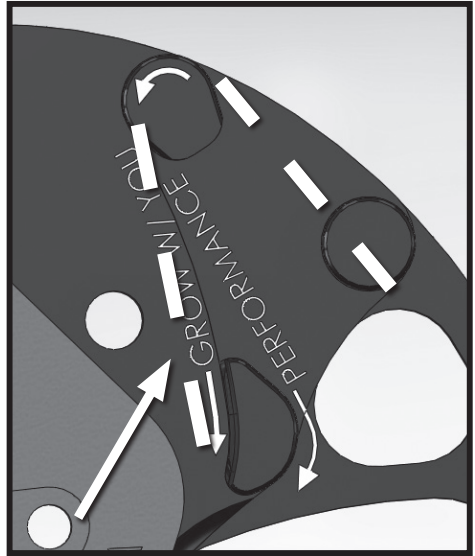

**PSE FEVER 60# GROW WITH YOU
CABLE SETTINGS-LONG POST**

Inner Cam Stop Setting	Draw Length Setting	Draw Weight at Bottom	Draw Weight 13 Turns Off
A-L	28¾"	54	37¼
B-L	28½"	54	37¼
C-L	27¼"	54	37¼
D-L	26¾"	54	37¼
E-L	25½"	54	37¼
F-L	25"	54	37¼
G-L	24"	54	37¼
H-L	23¼"	54	37¼
I-L	22"	54	36
J-L	21½"	52¾	34¾
A-S	21"	51½	33½
B-S	19½"	49¼	32½
C-S	18¾"	48	31¼
D-S	17½"	43¼	28¾
E-S	17"	40¾	26½
F-S	16"	36	24
G-S	15½"	33½	21½
H-S	14½"	28¾	19¼
I-S	14¼"	28¾	19¼
J-S	13½"	28¾	19¼

**PSE FEVER 60# GROW WITH YOU
CABLE SETTINGS-SHORT POST**

Inner Cam Stop Setting	Draw Length Setting	Draw Weight at Bottom	Draw Weight 13 Turns Off
A-L	27¾"	49¼	33½
B-L	27¼"	49¼	33½
C-L	26"	49¼	33½
D-L	25½"	49¼	33½
E-L	24½"	49¼	33½
F-L	24"	48	32½
G-L	22¾"	46¾	31¼
H-L	22¼"	45½	31¼
I-L	21"	43¼	28¾
J-L	20"	42	28¾
A-S	19½"	40¾	31¼
B-S	18"	37¼	25¼
C-S	17½"	34¾	22¾
D-S	16"	30	20½
E-S	15¼"	27½	18
F-S	14"	22¾	14½
G-S	13½"	20½	13¼
H-S	12½"	15½	10¾
I-S	12"	13¼	9½
J-S	11"	13¼	8½

**PSE FEVER 50# GROW WITH YOU
CABLE SETTINGS-LONG POST**

Inner Cam Stop Setting	Draw Length Setting	Draw Weight at Bottom	Draw Weight 13 Turns Off
A-L	28¾"	45	31
B-L	28½"	45	31
C-L	27¼"	45	31
D-L	26¾"	45	31
E-L	25½"	45	31
F-L	25"	45	31
G-L	24"	45	31
H-L	23¼"	45	31
I-L	22"	45	30
J-L	21½"	44	29
A-S	21"	43	28
B-S	19½"	41	27
C-S	18¾"	40	26
D-S	17½"	36	24
E-S	17"	34	22
F-S	16"	30	20
G-S	15½"	28	18
H-S	14½"	24	16
I-S	14¼"	24	16
J-S	13½"	24	16

**PSE FEVER 50# GROW WITH YOU
CABLE SETTINGS-SHORT POST**

Inner Cam Stop Setting	Draw Length Setting	Draw Weight at Bottom	Draw Weight 13 Turns Off
A-L	27¾"	41	28
B-L	27¼"	41	28
C-L	26"	41	28
D-L	25½"	41	28
E-L	24½"	41	28
F-L	24"	40	27
G-L	22¾"	39	26
H-L	22¼"	38	26
I-L	21"	36	24
J-L	20"	35	24
A-S	19½"	34	26
B-S	18"	31	21
C-S	17½"	29	19
D-S	16"	25	17
E-S	15¼"	23	15
F-S	14"	19	12
G-S	13½"	17	11
H-S	12½"	13	9
I-S	12"	11	8
J-S	11"	11	7

**PSE FEVER 40# GROW WITH YOU
CABLE SETTINGS-LONG POST**

Inner Cam Stop Setting	Draw Length Setting	Draw Weight at Bottom	Draw Weight 13 Turns Off
A-L	28¾"	36	24¾
B-L	28½"	36	24¾
C-L	27¼"	36	24¾
D-L	26¾"	36	24¾
E-L	25½"	36	24¾
F-L	25"	36	24¾
G-L	24"	36	24¾
H-L	23¼"	36	24¾
I-L	22"	36	24
J-L	21½"	35¼	23¼
A-S	21"	34½	22½
B-S	19½"	32¾	21½
C-S	18¾"	32	20¾
D-S	17½"	28¾	19¼
E-S	17"	27¼	17½
F-S	16"	24	16
G-S	15½"	22½	14½
H-S	14½"	19¼	12¾
I-S	14¼"	19¼	12¾
J-S	13½"	19¼	12¾

**PSE FEVER 40# GROW WITH YOU
CABLE SETTINGS-SHORT POST**

Inner Cam Stop Setting	Draw Length Setting	Draw Weight at Bottom	Draw Weight 13 Turns Off
A-L	27¾"	32¾	21½
B-L	27¼"	32¾	21½
C-L	26"	32¾	21½
D-L	25½"	32¾	21½
E-L	24½"	32¾	21½
F-L	24"	32	21½
G-L	22¾"	31¼	20¾
H-L	22¼"	30½	20¾
I-L	21"	28¾	19¼
J-L	20"	28	19¼
A-S	19½"	27¼	20¾
B-S	18"	24¾	16¾
C-S	17½"	23¼	15¼
D-S	16"	20	13½
E-S	15¼"	18½	12
F-S	14"	15¼	9½
G-S	13½"	13½	8¾
H-S	12½"	10½	7¼
I-S	12"	8¾	6½
J-S	11"	8¾	5½

**PSE FEVER 29# GROW WITH YOU
CABLE SETTINGS-LONG POST**

Inner Cam Stop Setting	Draw Length Setting	Draw Weight at Bottom	Draw Weight 13 Turns Off
A-L	28¾"	26	18
B-L	28½"	26	18
C-L	27¼"	26	18
D-L	26¾"	26	18
E-L	25½"	26	18
F-L	25"	26	18
G-L	24"	26	18
H-L	23¼"	26	18
I-L	22"	26	17½
J-L	21½"	25½	16¾
A-S	21"	25	16¼
B-S	19½"	23¾	15¾
C-S	18¾"	23¼	15
D-S	17½"	21	14
E-S	17"	19¾	12¾
F-S	16"	17½	11½
G-S	15½"	16¼	10½
H-S	14½"	14	9¼
I-S	14¼"	14	9¼
J-S	13½"	14	9¼

**PSE FEVER 29# GROW WITH YOU
CABLE SETTINGS-SHORT POST**

Inner Cam Stop Setting	Draw Length Setting	Draw Weight at Bottom	Draw Weight 13 Turns Off
A-L	27¾"	23¾	16¼
B-L	27¼"	23¾	16¼
C-L	26"	23¾	16¼
D-L	25½"	23¾	16¼
E-L	24½"	23¾	16¼
F-L	24"	23¼	15¾
G-L	22¾"	22½	15
H-L	22¼"	22	15
I-L	21"	21	14
J-L	20"	20¼	14
A-S	19½"	19¾	15
B-S	18"	18	12¼
C-S	17½"	16¾	11
D-S	16"	14½	9¾
E-S	15¼"	13¼	8¾
F-S	14"	11	7
G-S	13½"	9¾	6½
H-S	12½"	7½	5¼
I-S	12"	6½	4¾
J-S	11"	6½	4

MINI BURNER™ XT: PERFORMANCE DRAW SETTINGS

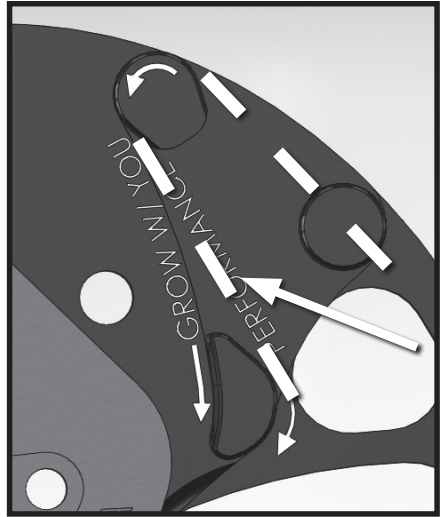

PSE MINI BURNER XT- 50# PERFORMANCE CABLE SETTINGS-LONG POST				PSE MINI BURNER XT- 50# PERFORMANCE CABLE SETTINGS-SHORT POST			
Inner Cam Stop Setting	Draw Length Setting	Draw Weight at Bottom	Draw Weight 8 Turns Off	Inner Cam Stop Setting	Draw Length Setting	Draw Weight at Bottom	Draw Weight 8 Turns Off
A-L	28¼"	50	37	A-L	27½"	43	33
B-L	28"	50	37	B-L	27¼"	43	33
C-L	27"	50	37	C-L	26"	43	33
D-L	26½"	50	35	D-L	25¾"	43	32
E-L	25¼"	50	35	E-L	24½"	43	32
F-L	25"	50	35	F-L	24"	43	32
G-L	23¾"	50	35	G-L	22¾"	42	32
H-L	23½"	50	35	H-L	22½"	42	31
I-L	22½"	50	35	I-L	21¼"	40	29
J-L	21½"	50	35	J-L	20¾"	40	29
A-S	21"	50	34	A-S	20"	40	29
B-S	20"	50	34	B-S	18¾"	40	29
C-S	19¼"	50	34	C-S	18"	40	29
D-S	18¼"	50	34	D-S	17¼"	40	29
E-S	18"	50	34	E-S	16¾"	40	29
F-S	17¾"	50	34	F-S	16½"	40	29
G-S	17½"	50	34	G-S	16¼"	40	29
H-S	17¼"	50	34	H-S	16"	40	29
I-S	17"	50	34	I-S	15¾"	40	28
J-S	16¾"	50	34	J-S	15½"	40	28

**PSE MINI BURNER XT- 40# PERFORMANCE
CABLE SETTINGS-LONG POST**

Inner Cam Stop Setting	Draw Length Setting	Draw Weight at Bottom	Draw Weight 8 Turns Off
A-L	28¼"	40	30
B-L	28"	40	30
C-L	27"	40	30
D-L	26½"	40	28
E-L	25¼"	40	28
F-L	25"	40	28
G-L	23¾"	40	28
H-L	23½"	40	28
I-L	22½"	40	28
J-L	21½"	40	28
A-S	21"	40	28
B-S	20"	40	27
C-S	19¼"	40	27
D-S	18¼"	40	27
E-S	18"	40	27
F-S	17¾"	40	27
G-S	17½"	40	27
H-S	17¼"	40	27
I-S	17"	40	27
J-S	16¾"	40	27

**PSE MINI BURNER XT- 40# PERFORMANCE
CABLE SETTINGS-SHORT POST**

Inner Cam Stop Setting	Draw Length Setting	Draw Weight at Bottom	Draw Weight 8 Turns Off
A-L	27½"	35	27
B-L	27¼"	35	27
C-L	26"	35	27
D-L	25¾"	35	26
E-L	24½"	35	26
F-L	24"	35	26
G-L	22¾"	34	26
H-L	22½"	34	25
I-L	21¼"	32	23
J-L	20¾"	32	23
A-S	20"	32	23
B-S	18¾"	32	23
C-S	18"	32	23
D-S	17¼"	32	23
E-S	16¾"	32	23
F-S	16½"	32	23
G-S	16¼"	32	23
H-S	16"	32	23
I-S	15¾"	32	23
J-S	15½"	32	23

**PSE MINI BURNER XT- 29# PERFORMANCE
CABLE SETTINGS-LONG POST**

Inner Cam Stop Setting	Draw Length Setting	Draw Weight at Bottom	Draw Weight 8 Turns Off
A-L	28¼"	29	21
B-L	28"	29	21
C-L	27"	29	21
D-L	26½"	29	20
E-L	25¼"	29	20
F-L	25"	29	20
G-L	23¾"	29	20
H-L	23½"	29	20
I-L	22½"	29	20
J-L	21½"	29	20
A-S	21"	29	20
B-S	20"	29	20
C-S	19¼"	29	20
D-S	18¼"	29	20
E-S	18"	29	20
F-S	17¾"	29	20
G-S	17½"	29	20
H-S	17¼"	29	20
I-S	17"	29	20
J-S	16¾"	29	20

**PSE MINI BURNER XT- 29# PERFORMANCE
CABLE SETTINGS-SHORT POST**

Inner Cam Stop Setting	Draw Length Setting	Draw Weight at Bottom	Draw Weight 8 Turns Off
A-L	27½"	25	19
B-L	27¼"	25	19
C-L	26"	25	19
D-L	25¾"	25	19
E-L	24½"	25	19
F-L	24"	25	19
G-L	22¾"	24	19
H-L	22½"	24	18
I-L	21¼"	23	17
J-L	20¾"	23	17
A-S	20"	23	17
B-S	18¾"	23	17
C-S	18"	23	17
D-S	17¼"	23	17
E-S	16¾"	23	17
F-S	16½"	23	17
G-S	16¼"	23	17
H-S	16"	23	17
I-S	15¾"	23	16
J-S	15½"	23	16

**PSE MINI BURNER XT- 20# PERFORMANCE
CABLE SETTINGS-LONG POST**

Inner Cam Stop Setting	Draw Length Setting	Draw Weight at Bottom	Draw Weight 8 Turns Off
A-L	28¼"	20	15
B-L	28"	20	15
C-L	27"	20	15
D-L	26½"	20	14
E-L	25¼"	20	14
F-L	25"	20	14
G-L	23¾"	20	14
H-L	23½"	20	14
I-L	22½"	20	14
J-L	21½"	20	14
A-S	21"	20	14
B-S	20"	20	14
C-S	19¼"	20	14
D-S	18¼"	20	14
E-S	18"	20	14
F-S	17¾"	20	14
G-S	17½"	20	14
H-S	17¼"	20	14
I-S	17"	20	14
J-S	16¾"	20	14

**PSE MINI BURNER XT- 20# PERFORMANCE
CABLE SETTINGS-SHORT POST**

Inner Cam Stop Setting	Draw Length Setting	Draw Weight at Bottom	Draw Weight 8 Turns Off
A-L	27½"	17	13
B-L	27¼"	17	13
C-L	26"	17	13
D-L	25¾"	17	13
E-L	24½"	17	13
F-L	24"	17	13
G-L	22¾"	17	13
H-L	22½"	17	13
I-L	21¼"	16	12
J-L	20¾"	16	12
A-S	20"	16	12
B-S	18¾"	16	12
C-S	18"	16	12
D-S	17¼"	16	12
E-S	16¾"	16	12
F-S	16½"	16	12
G-S	16¼"	16	12
H-S	16"	16	12
I-S	15¾"	16	11
J-S	15½"	16	11

MINI BURNER™ XT: GROW WITH YOU DRAW SETTINGS

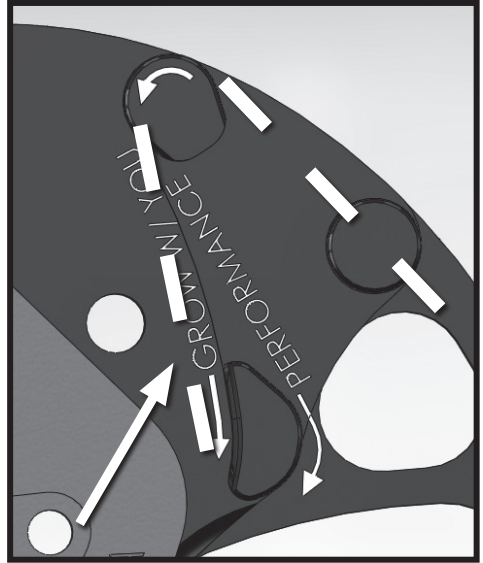

PSE MINI BURNER XT- 50# GROW WITH YOU CABLE SETTINGS-LONG POST

Inner Cam Stop Setting	Draw Length Setting	Draw Weight at Bottom	Draw Weight 8 Turns Off
A-L	28"	45	33
B-L	27¾"	45	33
C-L	26¾"	45	33
D-L	26¼"	45	32
E-L	25"	45	32
F-L	24¾"	45	32
G-L	23½"	45	32
H-L	23¼"	45	32
I-L	22"	45	32
J-L	21"	45	32
A-S	20¾"	44	31
B-S	19½"	40	30
C-S	19"	40	30
D-S	17¾"	37	27
E-S	17¼"	36	25
F-S	16"	30	23
G-S	15¾"	29	22
H-S	15"	26	20
I-S	14¾"	25	19
J-S	14"	25	19

PSE MINI BURNER XT- 50# GROW WITH YOU CABLE SETTINGS-SHORT POST

Inner Cam Stop Setting	Draw Length Setting	Draw Weight at Bottom	Draw Weight 8 Turns Off
A-L	27½"	40	30
B-L	27"	40	30
C-L	25¾"	40	30
D-L	25½"	39	30
E-L	24"	39	29
F-L	23¾"	39	29
G-L	22½"	38	29
H-L	22½"	38	28
I-L	21"	36	27
J-L	20½"	36	26
A-S	19¾"	34	26
B-S	18½"	32	24
C-S	17¾"	29	22
D-S	16½"	27	19
E-S	15½"	25	17
F-S	14¾"	21	15
G-S	14"	19	11
H-S	13"	16	11
I-S	12¾"	14	10
J-S	11½"	14	9

**PSE MINI BURNER XT- 40# GROW WITH YOU
CABLE SETTINGS-LONG POST**

Inner Cam Stop Setting	Draw Length Setting	Draw Weight at Bottom	Draw Weight 8 Turns Off
A-L	28"	36	26½
B-L	27¾"	36	26½
C-L	26¾"	36	26½
D-L	26¼"	36	25½
E-L	25"	36	25½
F-L	24¾"	36	25½
G-L	23½"	36	25½
H-L	23¼"	36	25½
I-L	22"	36	25½
J-L	21"	36	25½
A-S	20¾"	35¼	24¾
B-S	19½"	32	24
C-S	19"	32	24
D-S	17¾"	29½	21½
E-S	17¼"	28¾	20
F-S	16"	24	18½
G-S	15¾"	23¼	17½
H-S	15"	20¾	16
I-S	14¾"	20	15¼
J-S	14"	20	15¼

**PSE MINI BURNER XT- 40# GROW WITH YOU
CABLE SETTINGS-SHORT POST**

Inner Cam Stop Setting	Draw Length Setting	Draw Weight at Bottom	Draw Weight 8 Turns Off
A-L	27¼"	32	24
B-L	27"	32	24
C-L	25¾"	32	24
D-L	25½"	31¼	24
E-L	24"	31¼	23¼
F-L	23¾"	31¼	23¼
G-L	22½"	30½	23¼
H-L	22½"	30½	22½
I-L	21"	28¾	21½
J-L	20½"	28¾	20¾
A-S	19¾"	27¼	20¾
B-S	18½"	25½	19¼
C-S	17¾"	23¼	17½
D-S	16½"	21½	15¼
E-S	15½"	20	13½
F-S	14¾"	16¾	12
G-S	14"	15¼	8¾
H-S	13"	12¾	8¾
I-S	12¾"	11¼	8
J-S	11½"	11¼	7¼

**PSE MINI BURNER XT- 29# GROW WITH YOU
CABLE SETTINGS-LONG POST**

Inner Cam Stop Setting	Draw Length Setting	Draw Weight at Bottom	Draw Weight 8 Turns Off
A-L	28"	26	19¼
B-L	27¾"	26	19¼
C-L	26¾"	26	19¼
D-L	26¼"	26	18½
E-L	25"	26	18½
F-L	24¾"	26	18½
G-L	23½"	26	18½
H-L	23¼"	26	18½
I-L	22"	26	18½
J-L	21"	26	18½
A-S	20¾"	25½	18
B-S	19½"	23¼	17½
C-S	19"	23¼	17½
D-S	17¾"	21½	15¾
E-S	17¼"	21	14½
F-S	16"	17½	13¼
G-S	15¾"	16¾	12¾
H-S	15"	15	11½
I-S	14¾"	14½	11
J-S	14"	14½	11

**PSE MINI BURNER XT- 29# GROW WITH YOU
CABLE SETTINGS-SHORT POST**

Inner Cam Stop Setting	Draw Length Setting	Draw Weight at Bottom	Draw Weight 8 Turns Off
A-L	27¼"	23¼	17½
B-L	27"	23¼	17½
C-L	25¾"	23¼	17½
D-L	25½"	22½	17½
E-L	24"	22½	16¾
F-L	23¾"	22½	16¾
G-L	22½"	22	16¾
H-L	22½"	22	16¾
I-L	21"	21	15¾
J-L	20½"	21	15
A-S	19¾"	19¾	15
B-S	18½"	18½	14
C-S	17¾"	16¾	12¾
D-S	16½"	15¾	11
E-S	15½"	14½	9¾
F-S	14¾"	12¼	8¾
G-S	14"	11	6½
H-S	13"	9¼	6½
I-S	12¾"	8	5¾
J-S	11½"	8	5¼

**PSE MINI BURNER XT- 20# GROW WITH YOU
CABLE SETTINGS-LONG POST**

Inner Cam Stop Setting	Draw Length Setting	Draw Weight at Bottom	Draw Weight 8 Turns Off
A-L	28"	18	13¼
B-L	27¾"	18	13¼
C-L	26¾"	18	13¼
D-L	26¼"	18	12¾
E-L	25"	18	12¾
F-L	24¾"	18	12¾
G-L	23½"	18	12¾
H-L	23¼"	18	12¾
I-L	22"	18	12¾
J-L	21"	18	12¾
A-S	20¾"	17½	12½
B-S	19½"	16	12
C-S	19"	16	12
D-S	17¾"	14¾	10¾
E-S	17¼"	14½	10
F-S	16"	12	9¼
G-S	15¾"	11½	8¾
H-S	15"	10½	8
I-S	14¾"	10	7½
J-S	14"	10	7½

**PSE MINI BURNER XT- 20# GROW WITH YOU
CABLE SETTINGS-SHORT POST**

Inner Cam Stop Setting	Draw Length Setting	Draw Weight at Bottom	Draw Weight 8 Turns Off
A-L	27¼"	16	12
B-L	27"	16	12
C-L	25¾"	16	12
D-L	25½"	15½	12
E-L	24"	15½	11½
F-L	23¾"	15½	11½
G-L	22½"	15¼	11½
H-L	22½"	15¼	11¼
I-L	21"	14½	10¾
J-L	20½"	14½	10½
A-S	19¾"	13½	10½
B-S	18½"	12¾	9½
C-S	17¾"	11½	8¾
D-S	16½"	10¾	7½
E-S	15½"	10	6¾
F-S	14¾"	8½	6
G-S	14"	7½	4½
H-S	13"	6½	4½
I-S	12¾"	5½	4
J-S	11½"	5½	3½



LIMITED LIFETIME WARRANTY

Each PSE Bow is backed by a PSE Limited Lifetime Warranty to the original owner for the life of the product. Product will be replaced or repaired to restore it to its original performance. Cables, strings, or wearable items are not covered by this warranty.

Evidence of abuse, mishandling, misuse, or alteration to any PSE product voids any claim to warranty.

PSE specifications on strings and cables must be adhered to. PSE cannot be held responsible for injury or product failure resulting from improper use or neglect of maintenance.

All bows must undergo string and cable changes every 5,000 shots or every 12 months to maintain PSE warranty coverage. Total arrow weight must be in accordance with the guidelines published by the Archery Trade Association (ATA) for minimum arrow weight/bow peak weight. Overstressing PSE compound bows by using arrows lighter than ATA guideline will void warranty and may cause damage to the bow or injury to the shooter.

PSE makes no other claims either expressed or implied. In the interest of product improvement and consumer safety, PSE reserves the right to make changes in product design, color, and specifications without notice.

PSE PATENT INFORMATION

Manufactured Under Patents:

5,960,778	7,347,196
6,112,732	RE36,942
6,176,231	7,699,045
6,360,735	7,832,388
6,889,683	7,891,349
6,968,837	

Licensed Under Patents:

5,921,227
5,782,229



THE PSE WEBSITE IS YOUR RESOURCE FOR EVERYTHING WE HAVE TO OFFER!

SEARCH...
Contact Us My Account
f MFCAST
f t
p

Home Shop PSE Dealer Locator @PSE Videos Media School Support Company

PSE
ARCHERY

HOME / SHOP / EVOLVE CAM (EC2) BOWS / PSE EVOLVE



Home to item

PSE Evolve

\$949.99

HANDEDNESS

DRAW WEIGHT

COLOR

[ADD TO CART](#)

SKU: N/A
Categories: Evolve Cam (EC2) Bows, Pro Series Compound Bows

PRODUCT DESCRIPTION

Evolve your hunt with the 2017 PSE Evolve!!! Engineered from the ground up to be the most comfortable hunting bow we've ever made, we started with our amazing new EVOLVE Cam System (EC2), which gives this hunting bow an unbelievable 90% let-off and the smoothest shot on the market.

But PSE wasn't done yet...we paired the EC2 with our all-new ultra stiff forged riser design for amazing rigidity and shot stability, our Wide-Track Limb System and Wedge Lock™ Speed Pocket for deadly accuracy and 348 lbs of crushing power, and topped it all off with our new Roller/Glide® cable guard system to eliminate friction. We also added built-in riser stabilization ports to deliver a bow that is pure shooting nirvana!

SPECIFICATIONS

ATA/NISO Speed	346-338 fps
Brace Height	6 1/4"
handedness	Left, Right
Axle to Axle	31"
Let-off	90% 80%
draw length	29"
Draw Length Range	24-1/2" to 30"
draw weight	70#, 65#
Mass Weight	4.3 lbs.

SEARCH...
Contact Us My Account
f MFCAST
f t
p

Home Shop PSE Dealer Locator @PSE Videos Media School Support Company

PSE
ARCHERY

HOME / SHOP / BOW ACCESSORIES / BOW SIGHTS / PSE AMP MICRO SIGHT



Home to item

PSE Amp Micro Sight

\$69.99

[ADD TO CART](#)

Category: Bow Sights

PRODUCT DESCRIPTION

- Gain black finish
- Micro-adjust windage & elevation
- 4x6 .015" full capsize pins
- 2" diameter housing for an enlarged field of view
- Bubble level for precision shooting
- True Blue sight light included
- Fixed plate mount extends from 4" to 4.314"
- Right or left hand

www.pse-archery.com

BUY PSE SIGNATURE ITEMS ONLINE!

For PSE shooters, our brand name means more than just a bow; it represents a lifestyle. PSE customers live our brand 24/7 through shirts, hats, gear, and other PSE-branded accessories. We've dramatically expanded our Signature Series line with an exciting selection of new products...so don't wait!

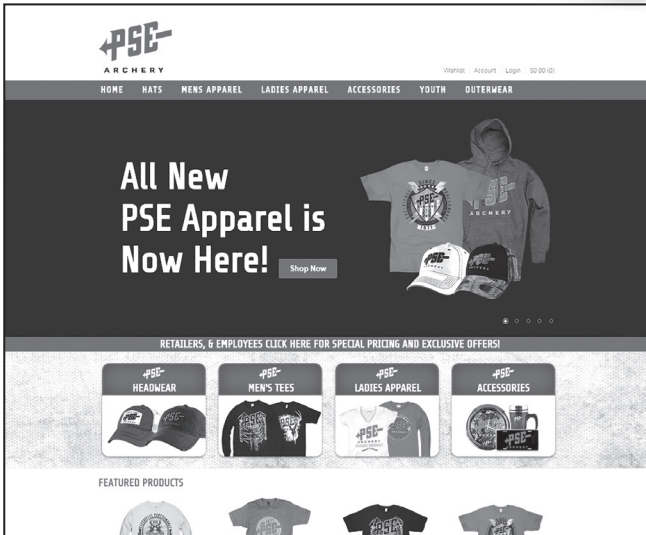

PSEARCHERYSTORE.COM





IMPORTANT

WARRANTY REGISTRATION

TO ACTIVATE YOUR BOW WARRANTY, PSE BOW REGISTRATION MUST BE RECEIVED BY PSE WITHIN 30 DAYS OF PURCHASE.

REGISTER YOUR BOW ONLINE OR COMPLETE THE INFORMATION AND MAIL-IN THE WARRANTY CARD INSERT.

ONLINE WARRANTY REGISTRATION

Log on at: www.pse-archery.com/registration



The PSE serial number is laser etched into your riser- opposite the shelf area.

NOTE: IF THE WARRANTY CARD IS NOT PRESENT, PLEASE USE THE FORM BELOW.

MAIL-IN WARRANTY REGISTRATION

Fill out the form below completely, remove it, place in a stamped envelope and mail to:

PSE WARRANTY REGISTRATION
P.O. Box 5487 Tucson, AZ 85703



SERIAL # OF BOW (SEE ABOVE FOR SERIAL # LOCATION) _____

BOW MODEL _____

DEALER NAME OR WHERE PURCHASED _____

YOUR NAME _____

YOUR ADDRESS _____ APT # _____

CITY _____ STATE _____ ZIP _____

COUNTRY _____ EMAIL ADDRESS _____

DATE PURCHASED ____/____/____ PHONE (____) _____