

Concept of Force and Newton's Laws of Motion

8.01
W02D2

Chapter 7 Newton's Laws of Motion,
Sections 7.1-7.4

Chapter 8 Applications of Newton's Second
Law,
Sections 8.1-8.4.1

Announcements

W02D3 Reading Assignment

[Chapter 8 Applications of Newton's Second Law](#),
Section 8.6: Example 8.6-8.9

Exam 1: Thursday Sept 19 7:30 pm - 9:30 pm

Newton's Laws of Motion: Review

First Law: *Every body continues in its state of rest, or of uniform motion in a right line, unless it is compelled to change that state by forces impressed upon it.*

Second Law: *The change of motion is proportional to the motive force impresses, and is made in the direction of the right line in which that force is impressed,*

$$\vec{\mathbf{F}} = m \vec{\mathbf{a}}.$$

Third Law: To every action there is always opposed an equal reaction: or, the mutual action of two bodies upon each other are always equal, and directed to contrary parts.

$$\vec{\mathbf{F}}_{1,2} = -\vec{\mathbf{F}}_{2,1}$$

$\vec{\mathbf{F}}_{1,2}$ \equiv force on 2 due to interaction between 1 and 2

Newton's Second Law: Physics and Mathematics

$$\vec{\mathbf{F}} = m\vec{\mathbf{a}}$$

physics \Leftrightarrow geometry

cause of motion
(why) \Leftrightarrow description of motion
(how)

dynamics \Leftrightarrow kinematics

Examples of Forces

- Gravity
- Electric and magnetic forces
- Elastic forces (Hooke's Law)
- Frictional forces: static and kinetic friction, fluid resistance
- Contact forces: normal forces and static friction
- Tension and compression

Force Law: Universal Law of Gravity

Gravitational force: $\vec{F}_{1,2}$
gravitational force on
body 2 due to the
interaction between
bodies 1 and 2

Magnitude: $|\vec{F}_{1,2}| = G \frac{m_1 m_2}{r_{12}^2}$

$$G = 6.67 \times 10^{-11} \text{ N} \cdot \text{m}^2 \cdot \text{kg}^{-2}$$

Direction: Attractive

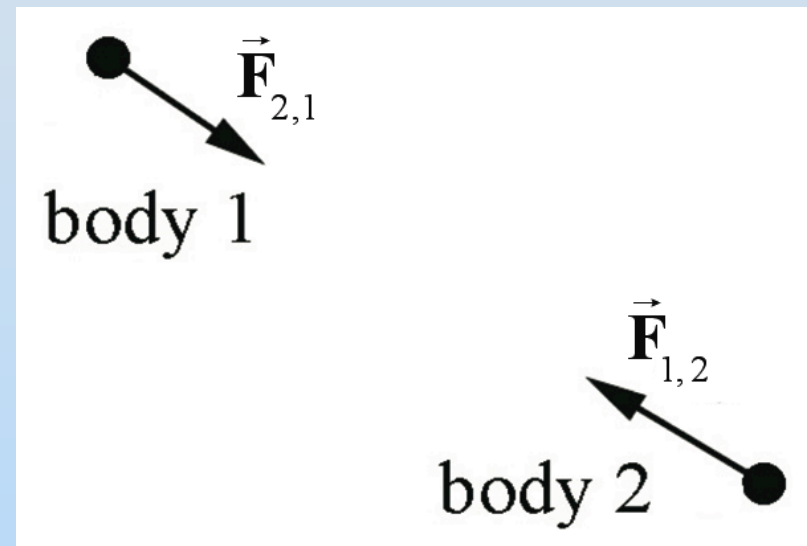

Force Law: Gravitational Force near the Surface of the Earth

Near the surface of the earth, the gravitational interaction between a body and the earth is mutually attractive and has a magnitude of

$$\left| \vec{\mathbf{F}}_{earth,object} \right| = m g = \frac{G m_E m}{R_E^2} \Rightarrow$$

$$g = \frac{G m_E}{R_E^2} = 9.81 \text{ m} \cdot \text{s}^{-2}$$

where m is the *gravitational mass* of the body, R_E is the radius of the earth, and M_E is the mass of the earth.

Tension Force

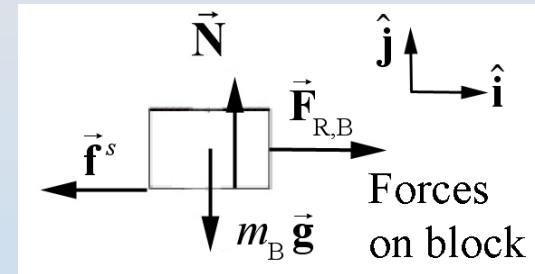
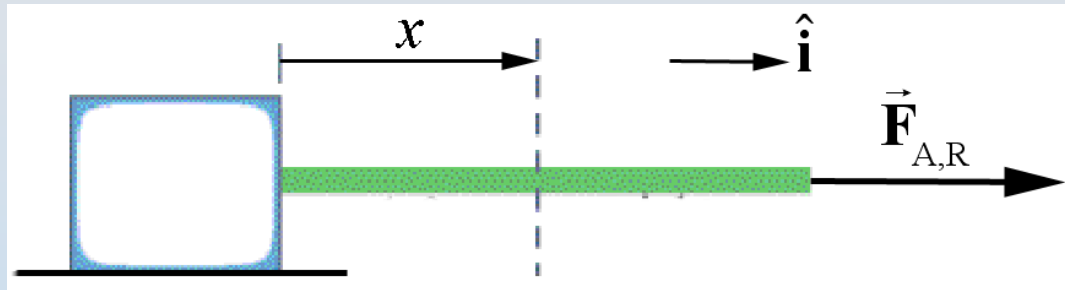

A rope is attached to a block B on one end, and pulled by an applied force from the other end. The force of the rope $\vec{F}_{R,B}$ on the block is called a **tension force**. Denote magnitude of tension force by

$$T \equiv \left| \vec{F}_{R,B} \right|$$

When rope is very light (massless) magnitude of tension force equal magnitude of the applied pulling force.

Concept Question: Tension

A cart is placed on a nearly frictionless surface. A force sensor on the cart is attached via a string to a hanging weight. The cart is initially held. When the cart is released and in motion does the tension in the string

1. increase?
2. stay the same?
3. decrease?
4. cannot determine. Need more information.

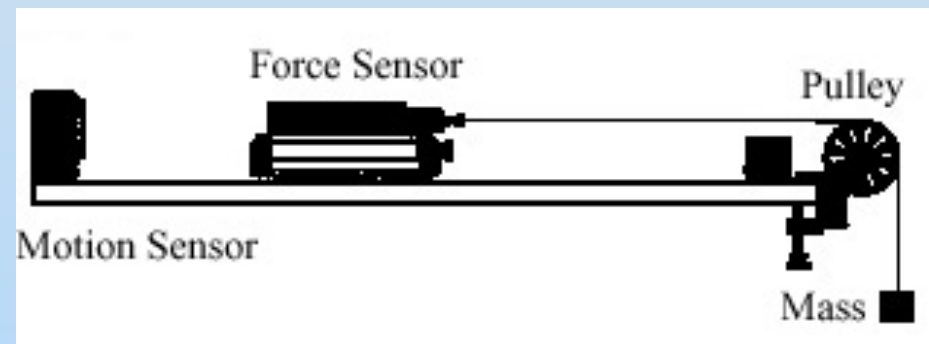

Force Law: Hooke's Law

Consider a mass m attached to a spring

Stretch or compress spring by different amounts produces different accelerations

Hooke's law: $|\vec{\mathbf{F}}| = k |\Delta l|$

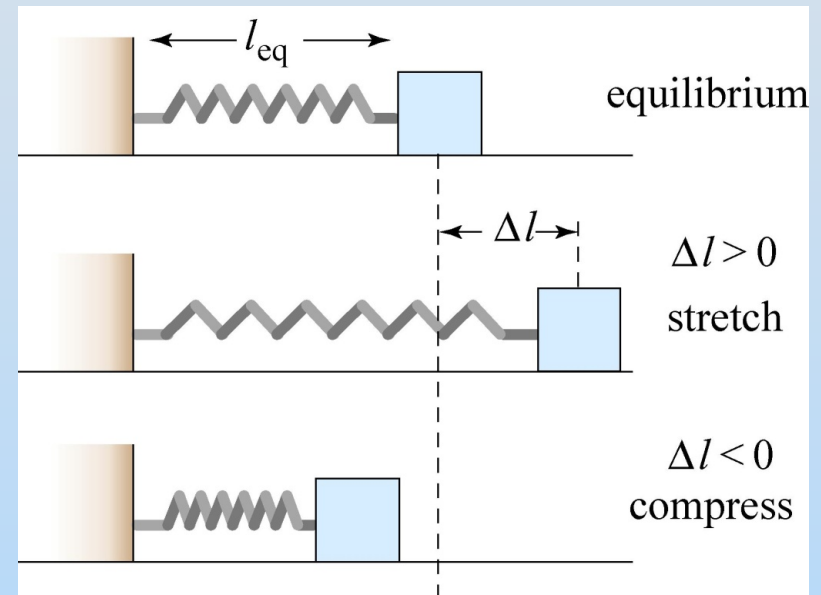

Direction: restoring spring to equilibrium

Hooke's law holds within some reasonable range of extension or compression

Worked Example: Spring Equation of Motion

For the spring force law:

$$\vec{F}_s = -F_s \hat{i} = -k(x - x_{eq}) \hat{i}$$

Newton's Second Law in
the *positive* \hat{i} -direction
(equation of motion)

$$-k(x - x_{eq}) = m \frac{d^2 x}{dt^2}$$

Solution: (later in course)

$$x(t) = x_{eq} + A \cos \left(\sqrt{\frac{k}{m}} t + \phi \right)$$

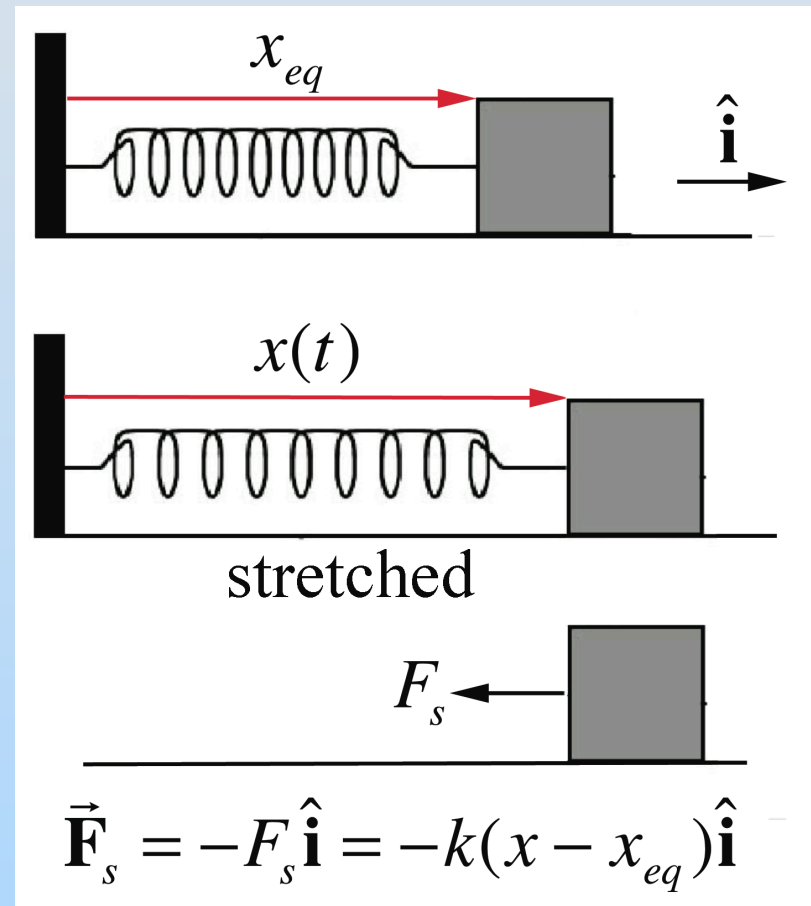

Force Law: Newtonian Induction

- Definition of force has no predictive content.
- Need to measure the acceleration and the mass in order to define the force.
- **Force Law:** Discover experimental relation between force exerted on object and change in properties of object.
- **Induction:** Extend force law from finite measurements to all cases within some range creating a **model**.
- **Second Law can now be used to predict motion!**
- If prediction disagrees with measurement adjust model.

Force Laws: Contact Forces Between Surfaces

The contact force on the hand between hand and surface is denoted by

$$\vec{F}_{surface,hand}^{total} \equiv \vec{C}$$

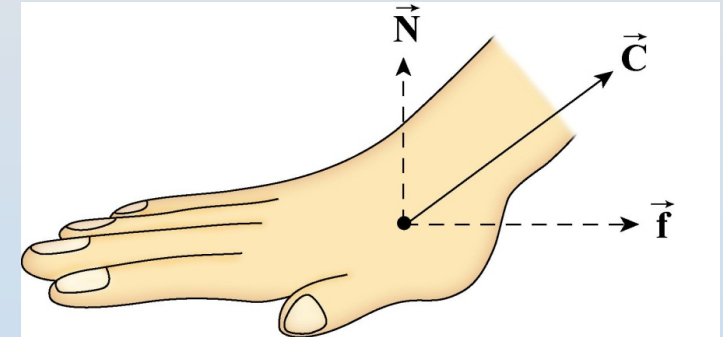

Normal Force: Component of the contact force on hand perpendicular to surface and is denoted by

$$\vec{F}_{surface,hand}^{normal} \equiv \vec{N}$$

Friction Force: Component of the contact force on hand tangent to the surface and is denoted by

$$\vec{F}_{surface,hand}^{tangent} \equiv \vec{f}$$

Therefore the contact force on hand can be modeled as a vector sum

$$\vec{C} \equiv \vec{N} + \vec{f}$$

Concept Question: Car-Earth Interaction

Consider a car at rest. We can conclude that the downward gravitational pull of Earth on the car and the upward contact force of Earth on it are equal and opposite because

1. the two forces form a third law interaction pair.
2. the net force on the car is zero.
3. neither of the above.
4. unsure

Concept Question: Normal Force

Consider a person standing in an elevator that is accelerating upward. The upward normal force N exerted by the elevator floor on the person is

1. larger than
2. identical to
3. smaller than

the downward force of gravity on the person.

Kinetic Friction

The kinetic frictional force f_k is proportional to the normal force, but independent of surface area of contact and the velocity.

The magnitude of f_k is

$$f_k = \mu_k N$$

where μ_k is the coefficients of friction.

Direction of f_k : opposes motion

Static Friction

Varies in direction and magnitude depending on applied forces:

$$0 \leq f_s \leq f_{s,\max} = \mu_s N$$

Static friction is equal to it's maximum value

$$f_{s,\max} = \mu_s N$$

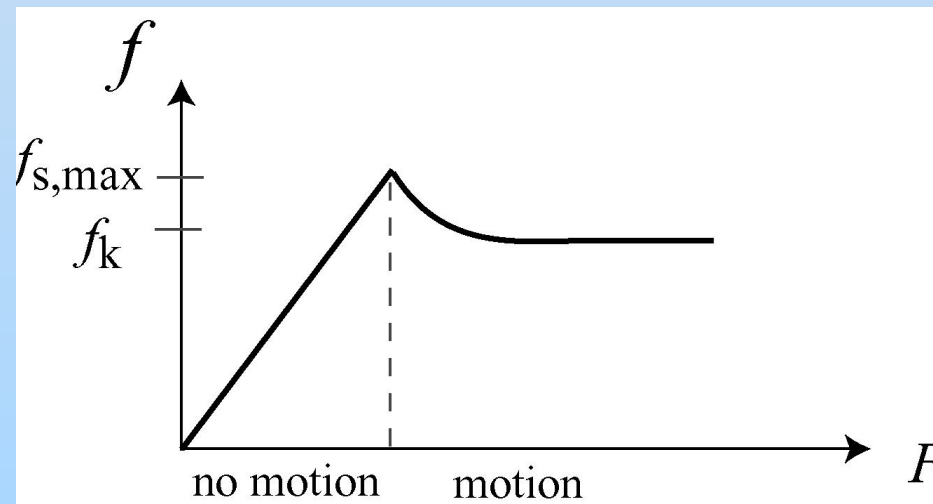

Tug of War Contest

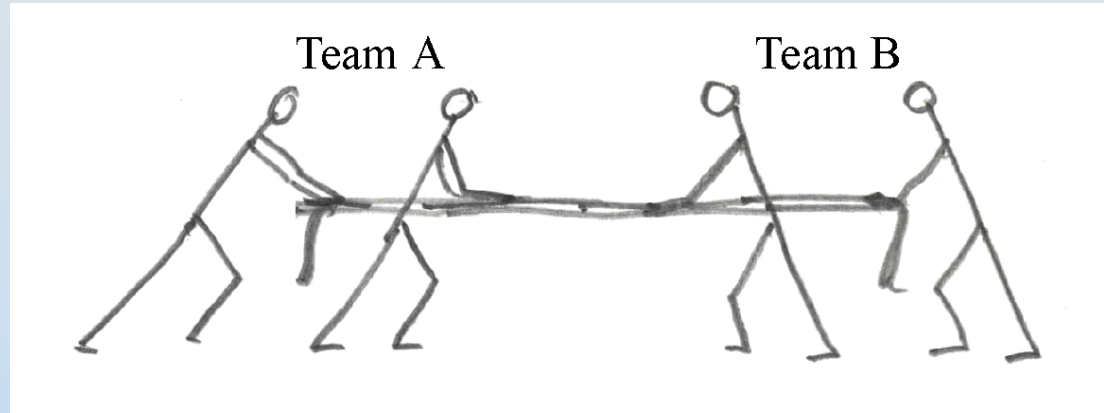

Each table forms a team of two students (one male and one female) and competes against the other tables in a tug of war until one table wins an elimination competition. The other students at the table figure out what forces are acting on their team and identify all interaction pairs of forces.

Tug of War Force Diagrams

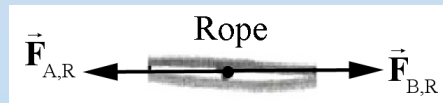
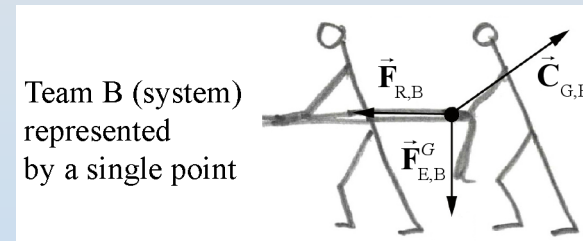
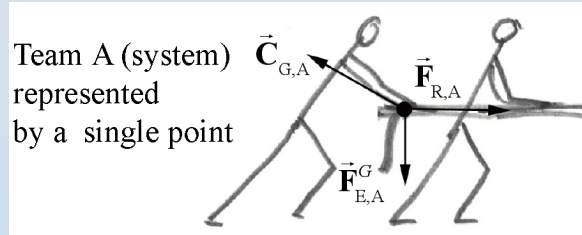

Each table forms a team of two students (one male and one female) and competes against the other tables in a tug of war until one table wins an elimination competition. The other students at the table figure out what forces are acting on their team and identify all interaction pairs of forces.

Free Body Diagram

- Represent each force that is acting on the object by an arrow on a **free body force diagram** that indicates the direction of the force

$$\vec{\mathbf{F}}^T = \vec{\mathbf{F}}_1 + \vec{\mathbf{F}}_2 + \dots$$

- Choose set of independent unit vectors and draw them on free body diagram.
- Decompose each force $\vec{\mathbf{F}}_i$ in terms of vector components.

$$\vec{\mathbf{F}}_i = F_{i,x} \hat{\mathbf{i}} + F_{i,y} \hat{\mathbf{j}} + F_{i,z} \hat{\mathbf{k}}$$

- Add vector components to find vector decomposition of the total force

$$F_x^T = F_{1,x}^T + F_{2,x}^T + \dots$$

$$F_y^T = F_{1,y}^T + F_{2,y}^T + \dots$$

$$F_z^T = F_{1,z}^T + F_{2,z}^T + \dots$$

Tab. Prob.: Free Body Force Diagrams

A block of mass M is sliding down an inclined plane with angle θ . There is kinetic friction between the block and the inclined plane with coefficient μ_k . The gravitational force on the block is directed in the downward vertical direction.

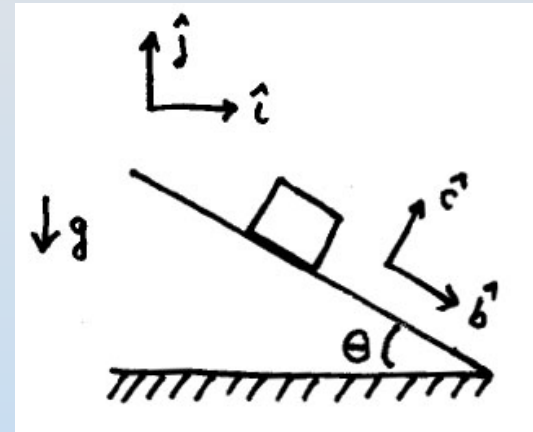

- Draw a free-body (force) diagram for the block. Clearly identify your forces with whatever symbols you find appropriate.
- For the coordinate system with unit vectors \hat{i} pointing horizontally to the right and \hat{j} pointing vertically upward, what are the vector components of the sum of the forces in the \hat{i} -direction and the \hat{j} -direction?
- For the coordinate system with unit vectors \hat{b} pointing along the inclined plane and \hat{c} pointing normal (perpendicular) to the plane as shown in the figure, what are the vector components of the sum of the forces in the \hat{b} -direction and the \hat{c} -direction?

Lecture Demo: Block with Pulley and Weight on Incline B24

<http://tsgphysics.mit.edu/front/index.php?page=demo.php&letnum=B%2024&show=0>

Worked Example: Pulley and Inclined Plane

A block of mass m_1 , constrained to move along a plane inclined at angle ϕ to the horizontal, is connected via a massless inextensible rope that passes over a massless pulley to a bucket to which sand is slowly added. The coefficient of static friction is μ_s . Assume the gravitational constant is g . What is the mass of the bucket and sand (m_2) just before the block slips upward?

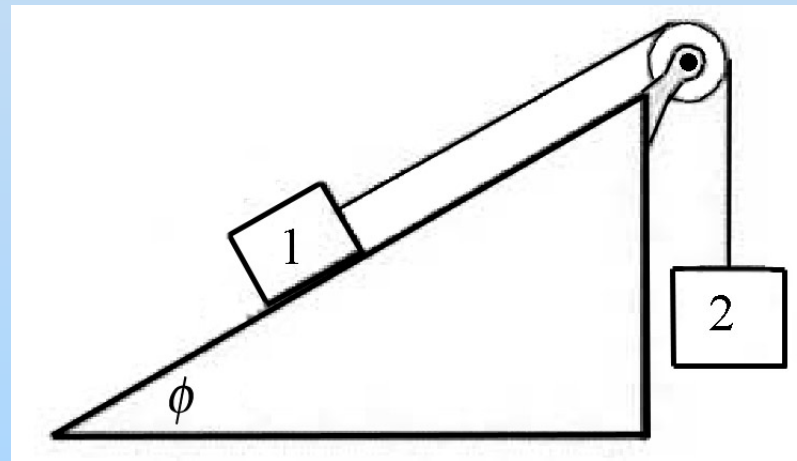

Solution: Pulley and Inclined Plane

Sketch and coordinate system

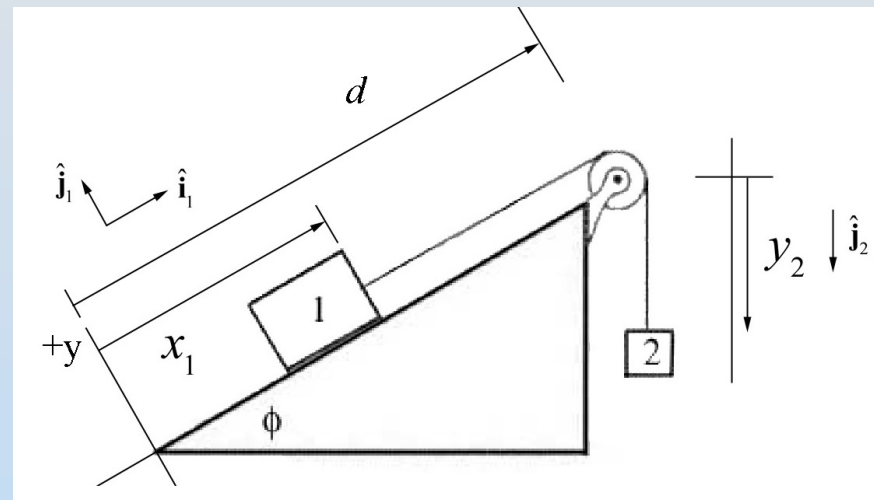

Free body force diagrams

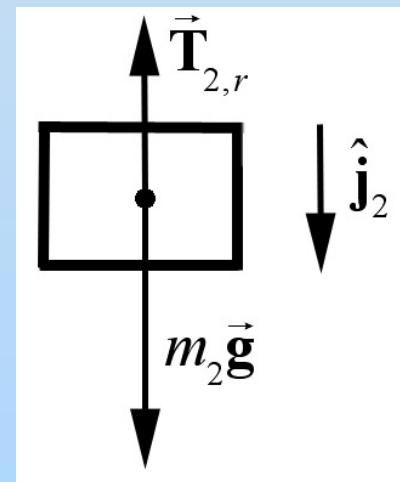
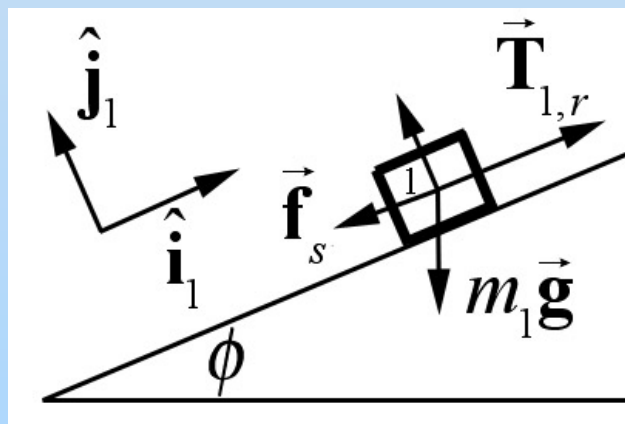

Newton's Second Law

Constraint Conditions

$$\vec{a}_1 = \vec{0}$$

$$\vec{a}_2 = \vec{0}$$

$$f_s = f_{s,\max} = \mu_s N$$

$$T \equiv T_{1,r} = T_{2,r}$$

Newton's Second Law

Object 1:

$$\hat{i}_1 : T - m_1 g \sin \phi - \mu_s N = 0$$

$$\hat{j}_1 : N - m_1 g \cos \phi = 0$$

Object 2:

$$\hat{j}_2 : T - m_2 g = 0$$

Simplification: $m_2 g - m_1 g \sin \phi - \mu_s m_1 g \cos \phi = 0$

Solution:

$$m_2 = m_1 (\sin \phi + \mu_s \cos \phi)$$

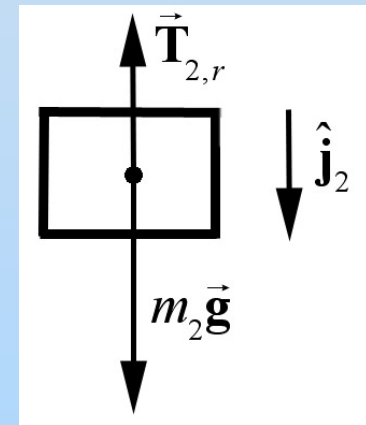
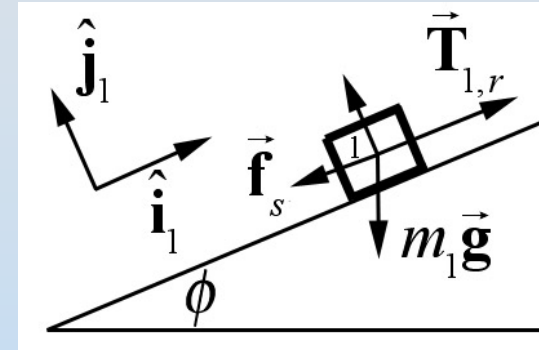

Mini-Experiment: Two Block Pull

Table Problem: Pulling Blocks

Consider two blocks that are resting one on top of the other. The lower block has M_2 and is resting on a nearly frictionless surface. The upper block has mass $M_1 < M_2$. Suppose the coefficient of static friction between the blocks is μ_s .

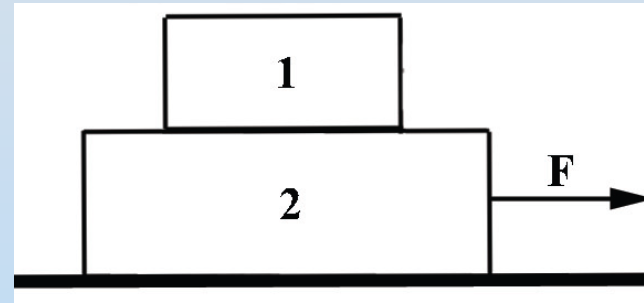
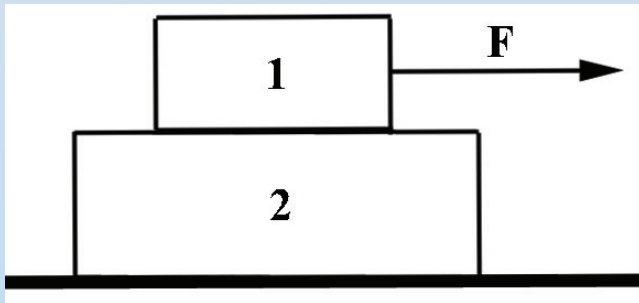

a) What is the maximum force with which the upper block can be pulled horizontally so that the two blocks move together without slipping? Draw as many free body force diagrams as you feel necessary. Identify all action-reaction pairs of forces in this problem.

b) What is the maximum force with which the lower block can be pulled horizontally so that the two blocks move together without slipping? Draw as many free body force diagrams as you feel necessary. Identify all action-reaction pairs of forces in this problem.