



SONOMA CAST STONE

CONCRETE WINE TANKS



CONCRETEWINETANKS.COM/CONICAL 877.283.2400



SONOMA CAST STONE

DID YOU KNOW?

Winemakers Around The World Have Returned To Concrete For Making Their Premium Wines.

Concrete offers the best of oak and stainless, by breathing depth and complexity into the wine without imparting any unwanted flavor to mask the fruit. In this way, concrete allows the wine to showcase its true terrior and taste more like where it's from with pure fruit, enhanced mouthfeel and a hint of crisp minerality.

The premiere American concrete manufacturer, **Sonoma Cast Stone**, long known for innovation in concrete product design and formulation, has been placing magnificent concrete fixtures in luxury hotels and restaurants as well as lush private homes for over 20 years.

With their jaw-dropping good looks and superior engineering, Sonoma Cast Stone concrete wine tanks have become the envy of the wine industry and are now sold around the world. Capacities from 240 to 28,000 gal.

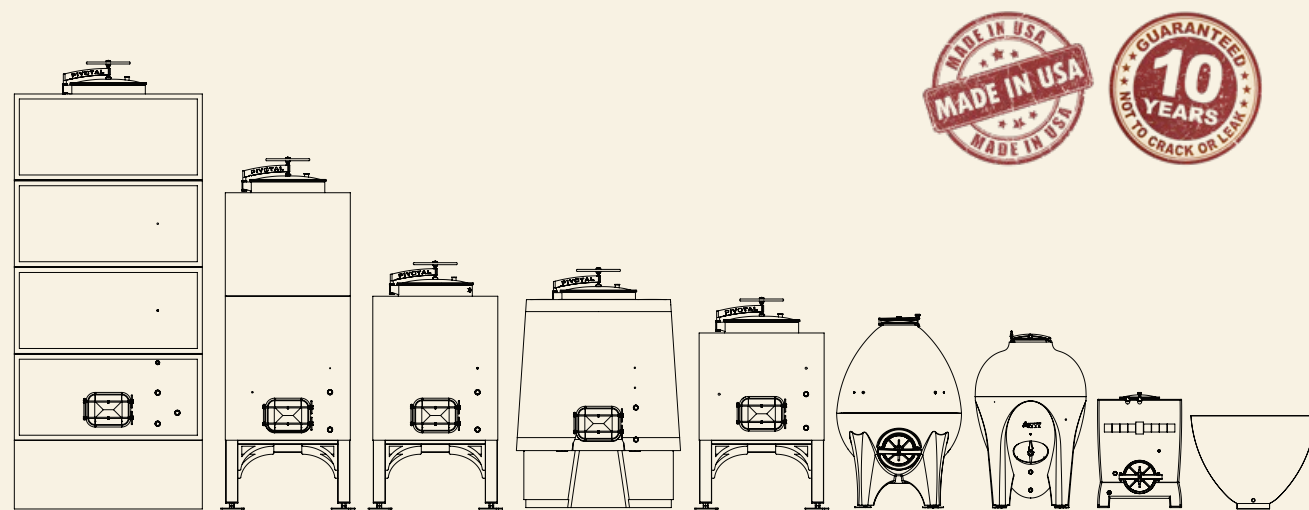

Only Sonoma Cast Stone Concrete Wine Tanks Are Guaranteed Not to Crack or Leak

Only Sonoma Cast Stone Concrete Wine Tanks Are Engineered with A System Of Layered Concrete?

The outer layer is a sprayed cementitious facecoat that gives a beautiful smooth appearance in any desired color. The second layer is a thick layup of high-tech glass-fiber reinforced concrete, which provides great strength and crack resistance. The inner, thickest layer is traditional cast concrete with no additives- just Portland Cement, sand, aggregate, and filtered water. This imparts unique concrete characteristics to the wine or beer. Temperature control tubing and any steel reinforcing are embedded in this layer. The three layers interlock for ultimate strength and resistance to cracking, and provide the added benefit of thermal mass for stable temperatures.

Only Sonoma Cast Stone Concrete Wine Tanks Are Made From Concrete Analyzed by The FDA

Sonoma Cast Stone is the only concrete vessel manufacturer to have our concrete analyzed by the FDA and determined safe for use in wine fermentation and aging.

Only Sonoma Cast Stone Concrete Wine Tanks Offer Your Choice Of Color

With dozens of natural and designer colors and the option of custom blending, Sonoma Cast Stone far outpaces the color options of any other manufacturer.

Only Sonoma Cast Stone Concrete Wine Tanks Offer Your Choice Of Logo Treatment

Only Sonoma Cast Stone Concrete Wine Tanks Are made in America!

Let us know when you're ready.

www.concretewinetanks.com



**Ask About Our Newest Innovation:
The Pivotal Manway / Details at Bottom.**



Conical | 830, 950, 1010_(elliptical), 1070 Gallons

Conical 31hl, 36hl, 38hl & 40hl

The conical design allows the lees to move with the wine, protecting it from oxidation. Thanks to its geometry, it is ideal for the fermentation of reds, since the liquid soaks the cap, helping to break it up and intensifying the maceration. It is the ideal model for délestage. Four sizes and styles of the popular Concrete Conical tanks are available. We take pride in being able to custom-modify these basic shapes to fit your winery. Conical tanks are available as open-top or closed with large manways. They can be placed on a raised foundation, powder coated steel adjustable ring support or matching concrete legs.

The easy clean pomace port makes this the ideal for both whites and reds. Our wine tanks, like our other fine fixtures, are hand-finished to showroom-quality. Available in your choice of color and featuring your winery logo these tanks are certain to WOW winery tours. As with all Sonoma Cast Stone products, this tank is superior in both design and quality of concrete.





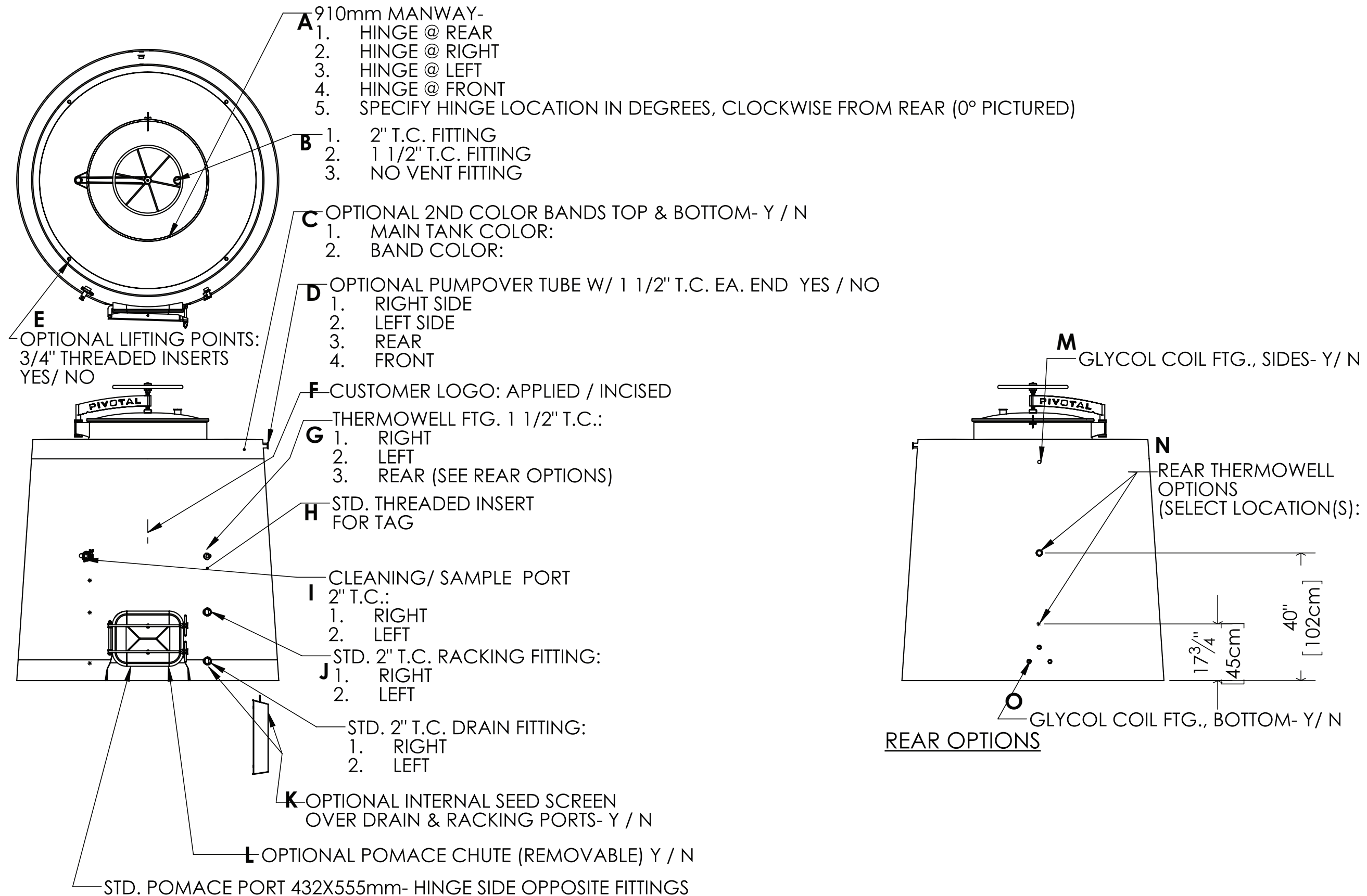

SLOPED TANK BASE CONFIGURATION FOR SLOPED PAD

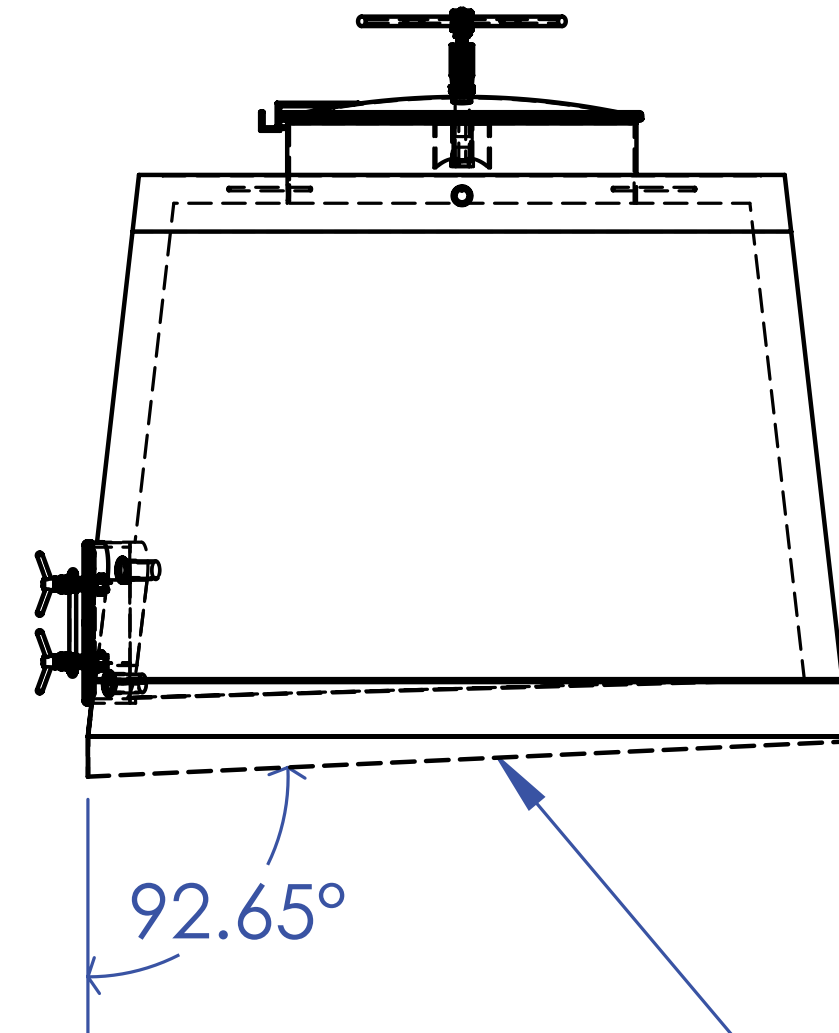
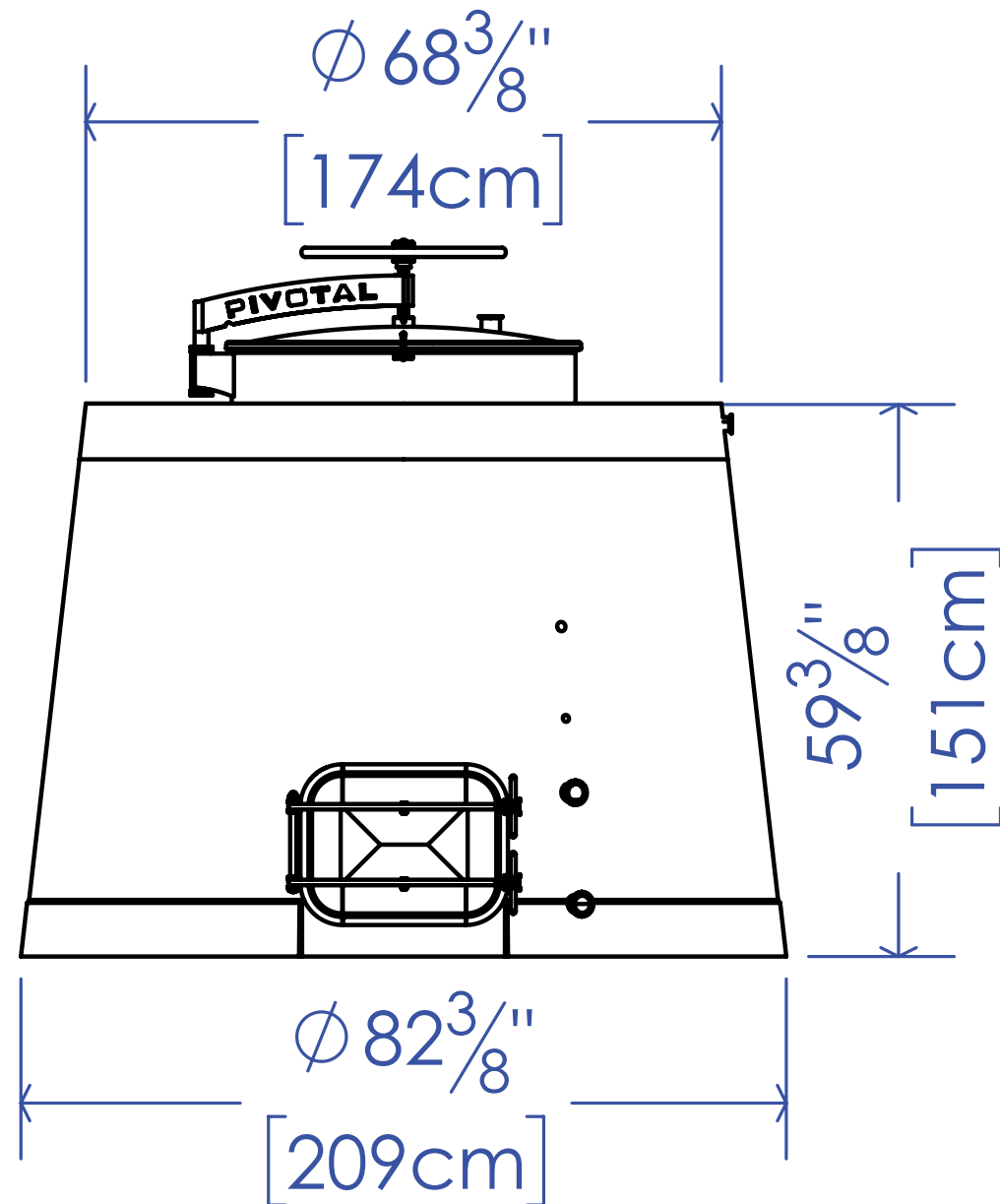

OPTIONAL SLOPED BASE
(INTERIOR SLOPE IS STANDARD)



LEVEL TANK BASE CONFIGURATION WITH THREE-PART CONCRETE LEGS

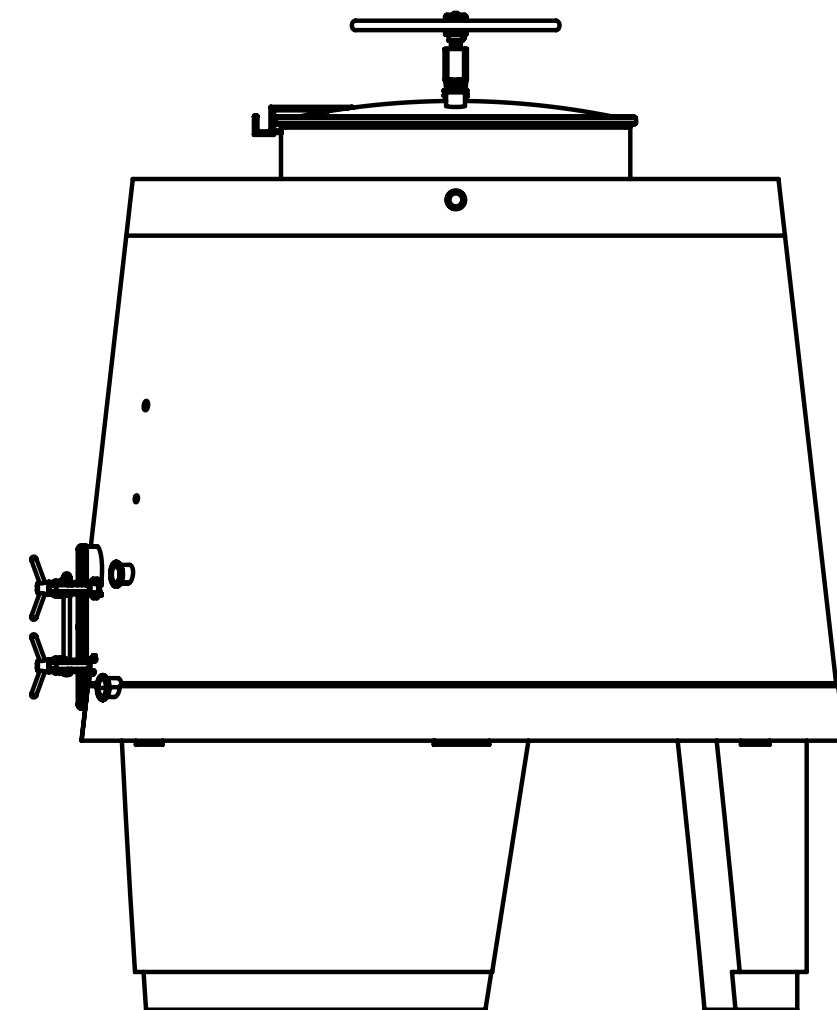
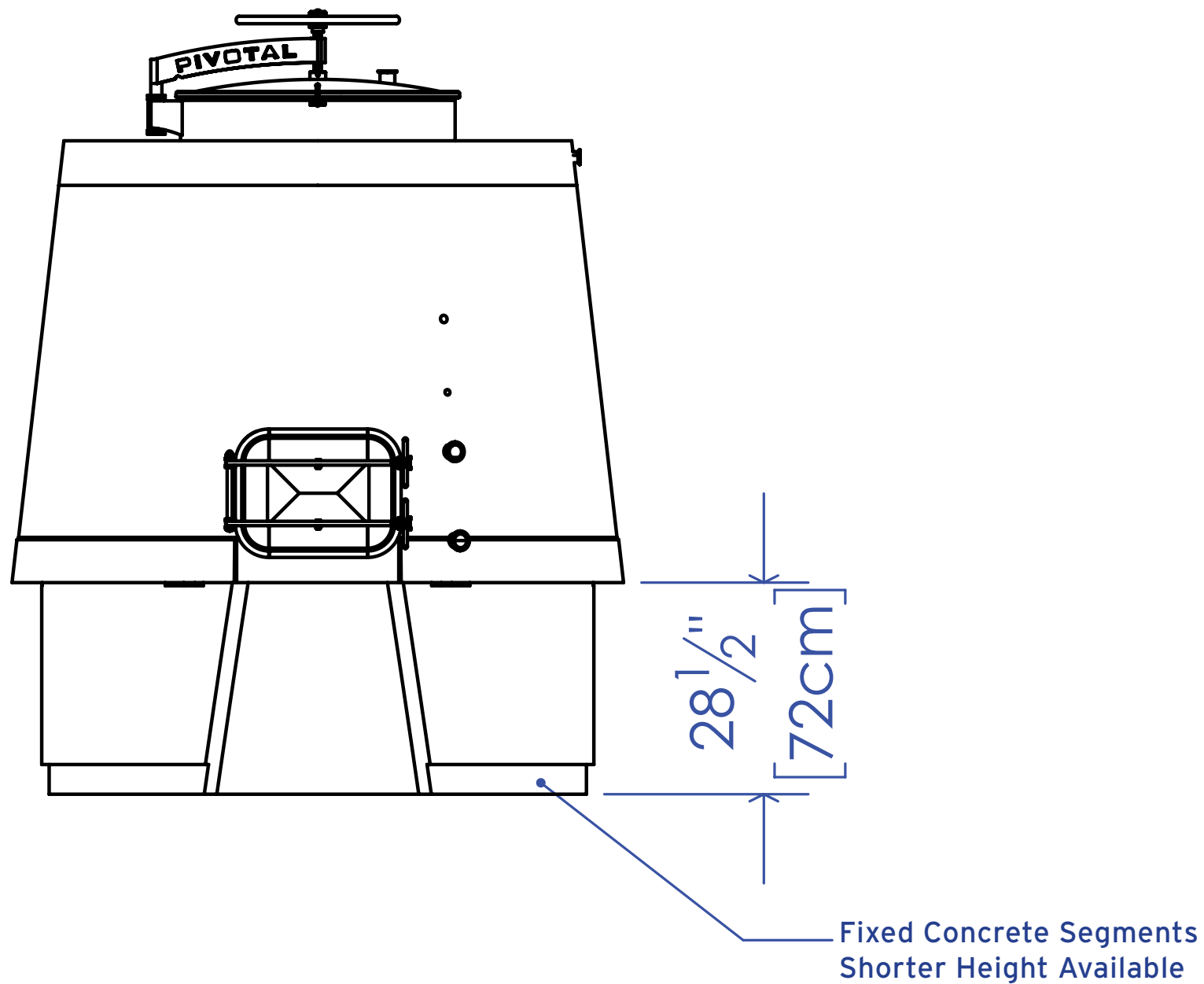

LEVEL TANK BASE CONFIGURATION WITH STAINLESS STEEL OR POWDER-COATED STEEL STAND

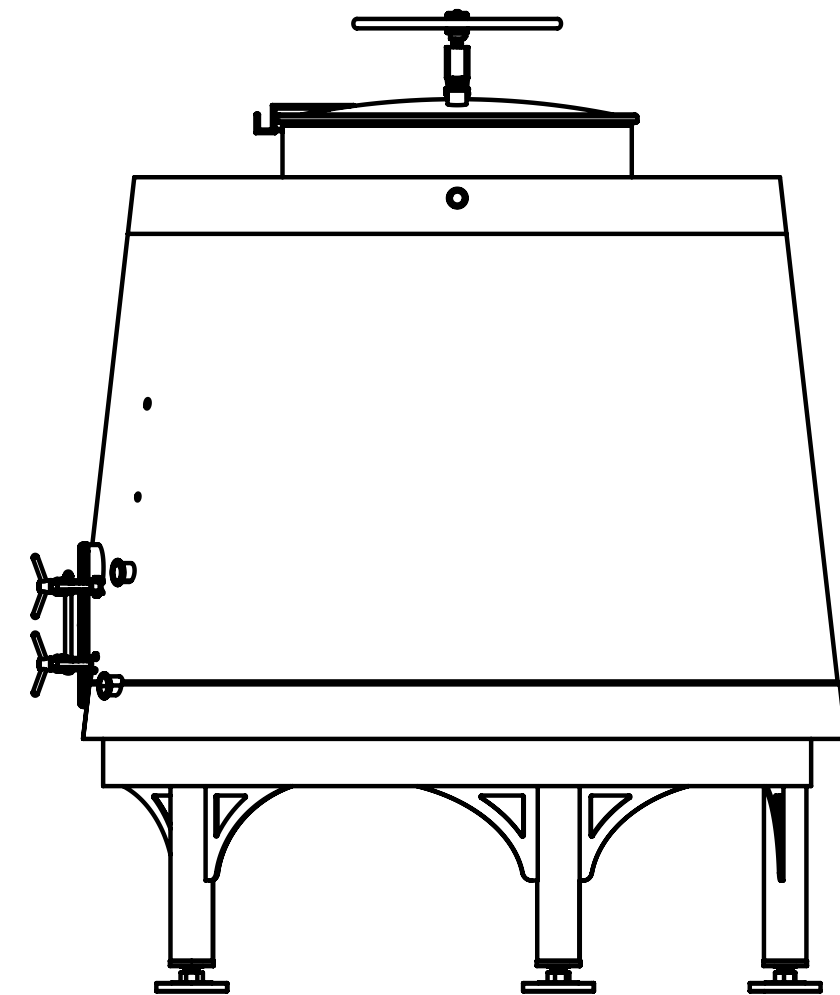
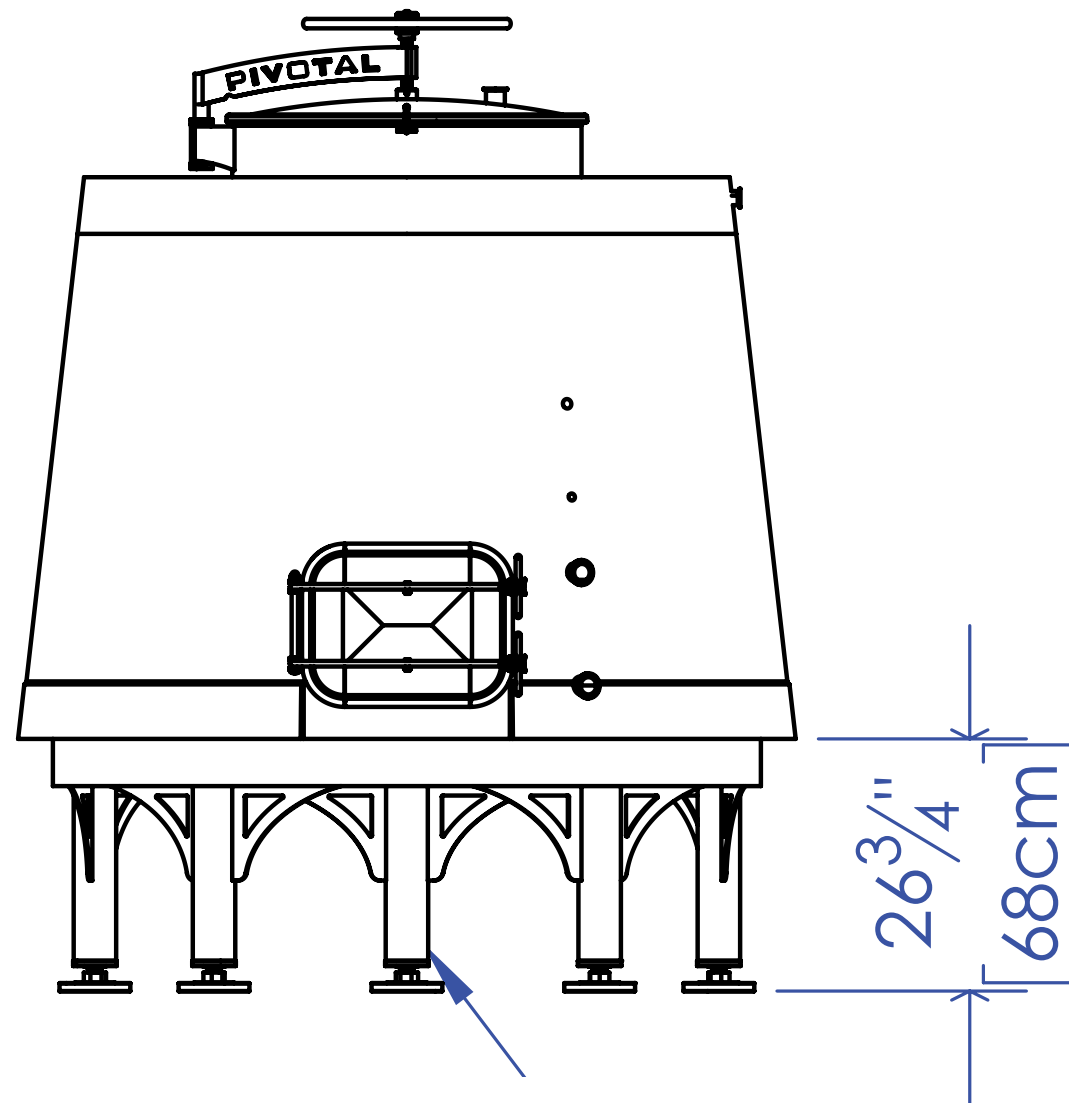

Tubular Leg w/Round Stainless Steel Foot,
Adjustable Height up to 32" Custom Heights Available



CONCRETE WINE TANKS
SONOMA CAST STONE

CONICAL 950

950 gal / 3,596 ltr / 36hl

Some items shown here may be optional and not included. Refer to your order.

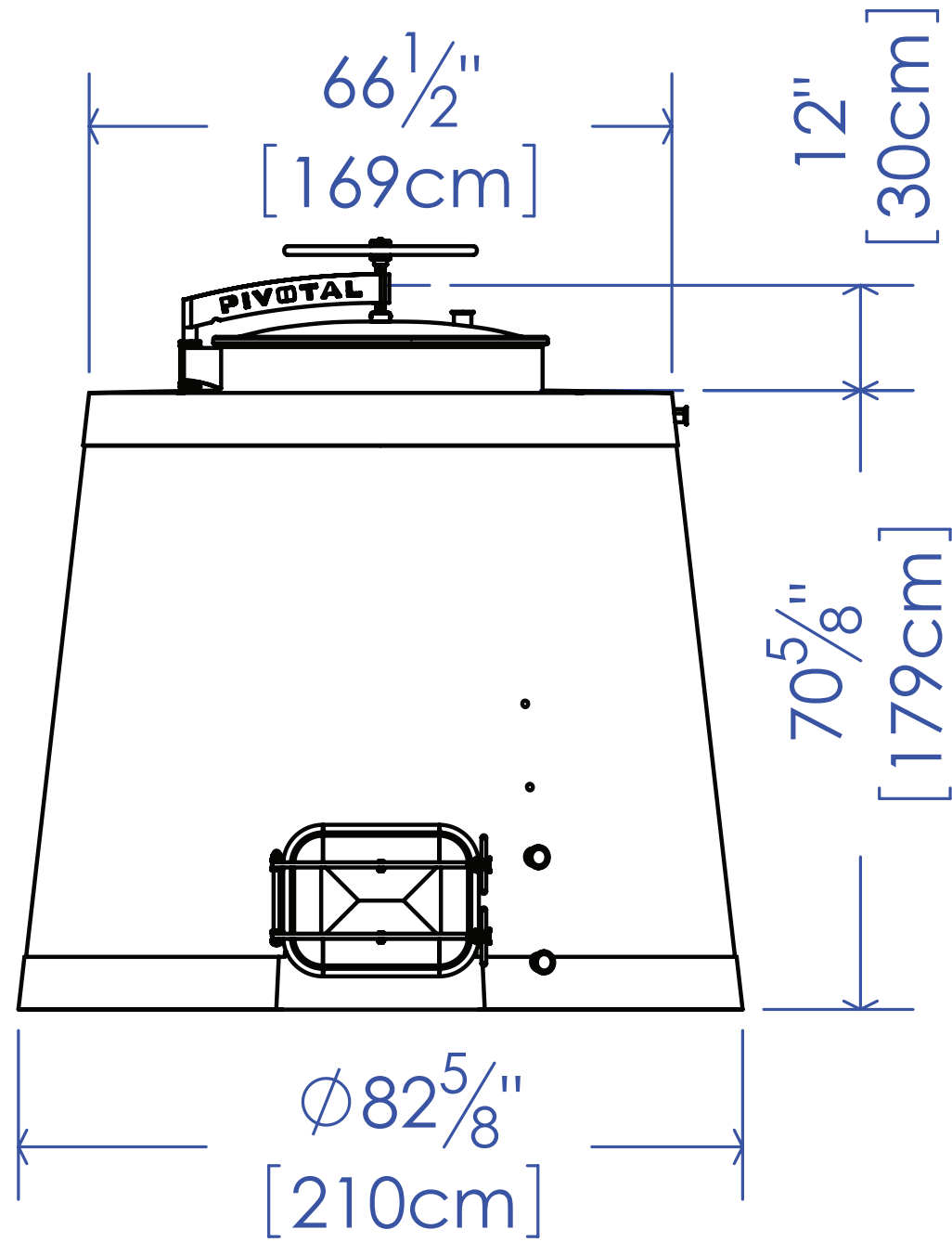

LEVEL TANK BASE CONFIGURATION

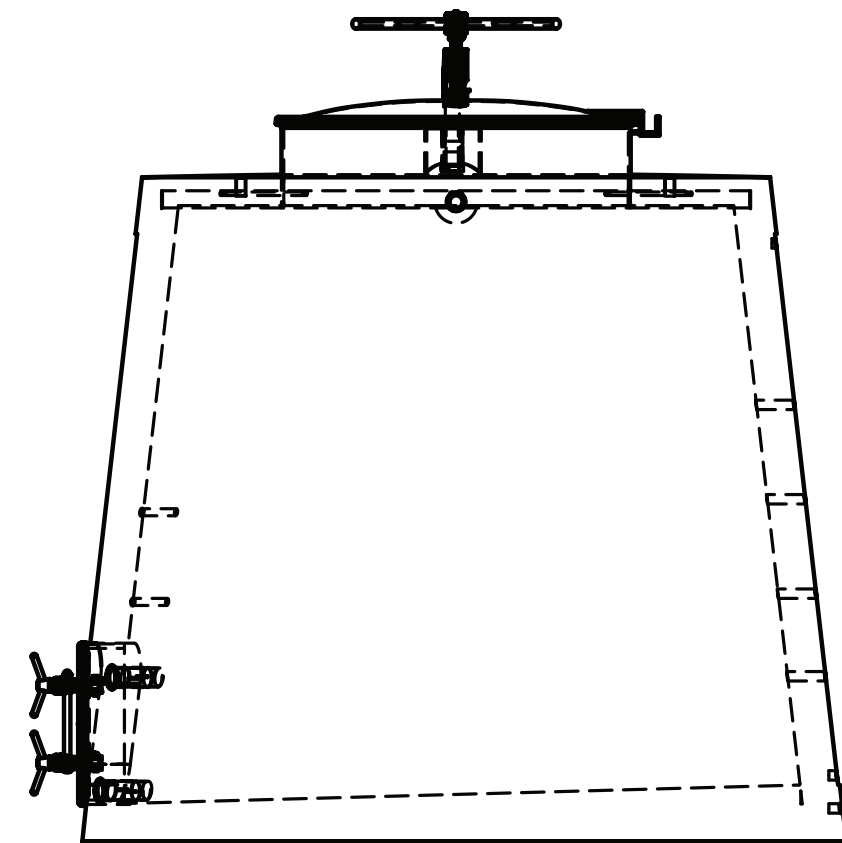

LEVEL TANK BASE CONFIGURATION WITH THREE-PART CONCRETE LEGS

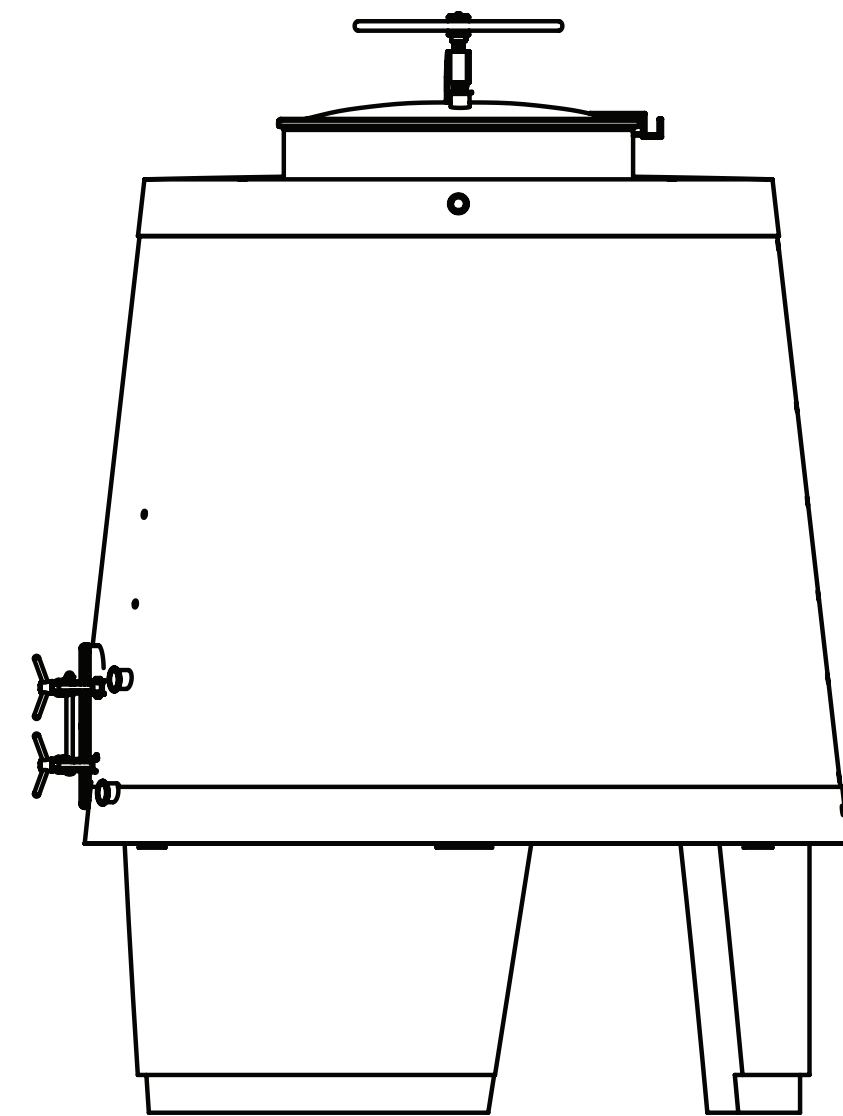
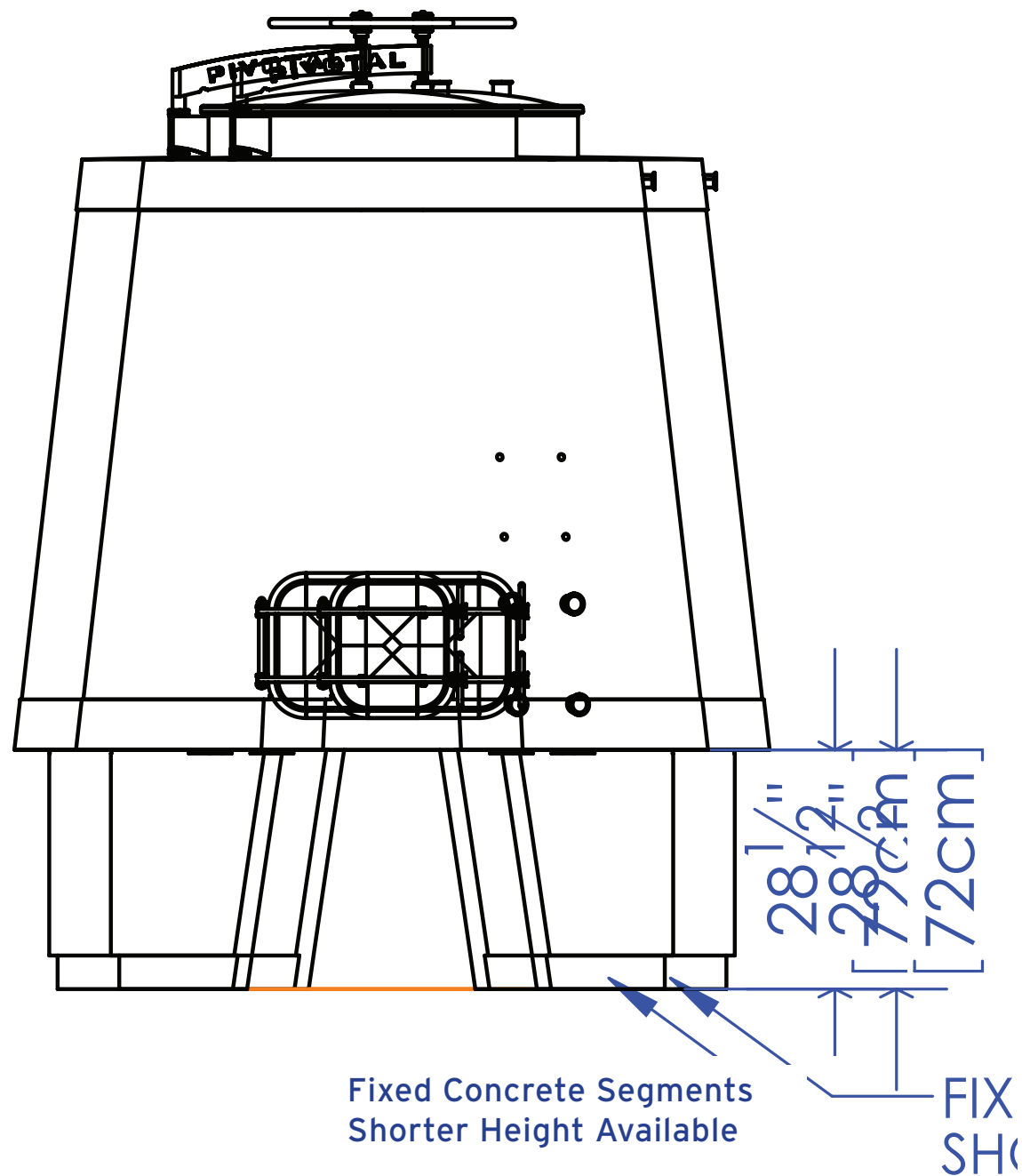

LEVEL TANK BASE CONFIGURATION WITH STAINLESS STEEL OR POWDER-COATED STEEL STAND

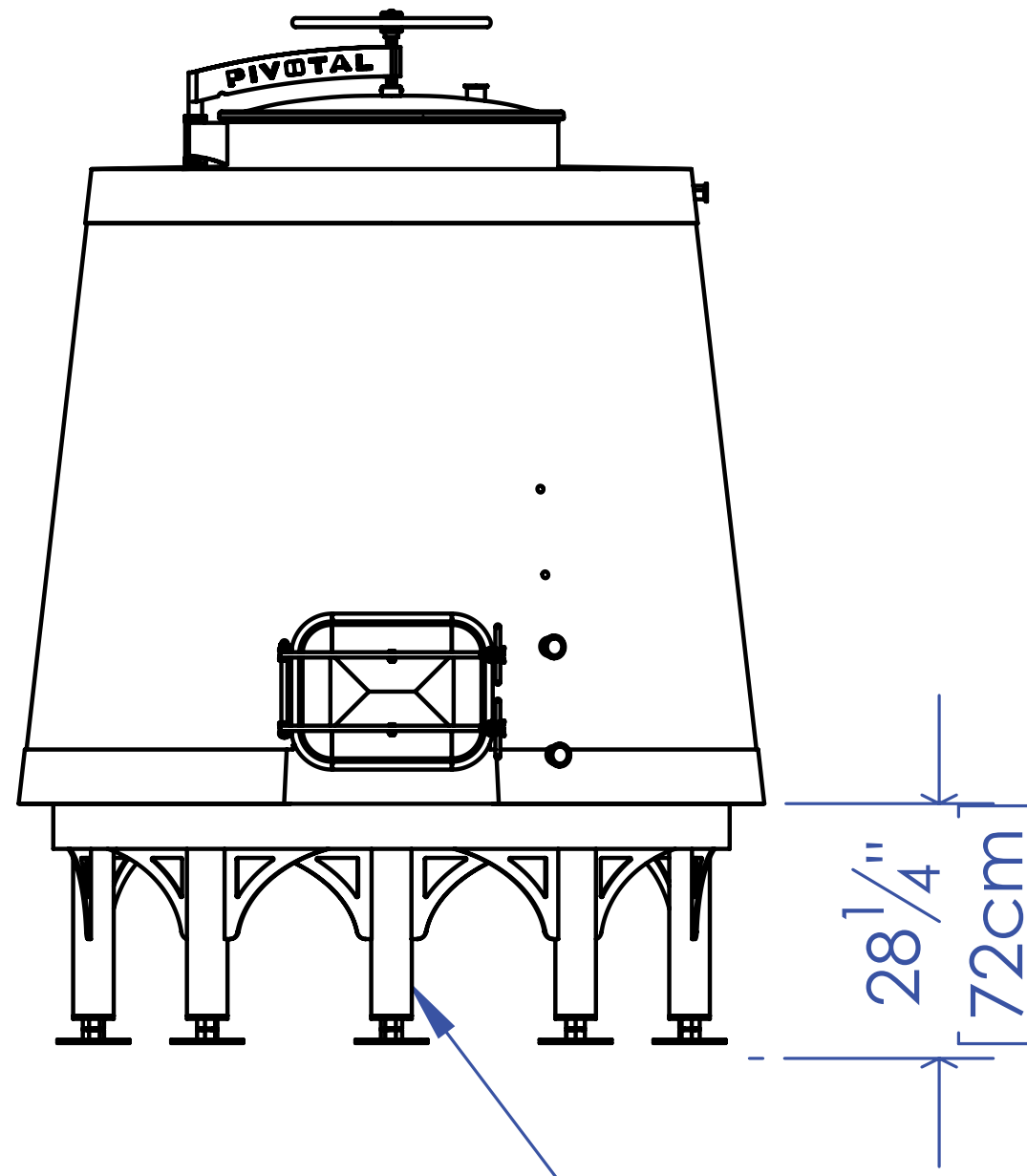

Tubular Leg w/Round Stainless Steel Foot,
Adjustable Height up to 32" Custom Heights Available

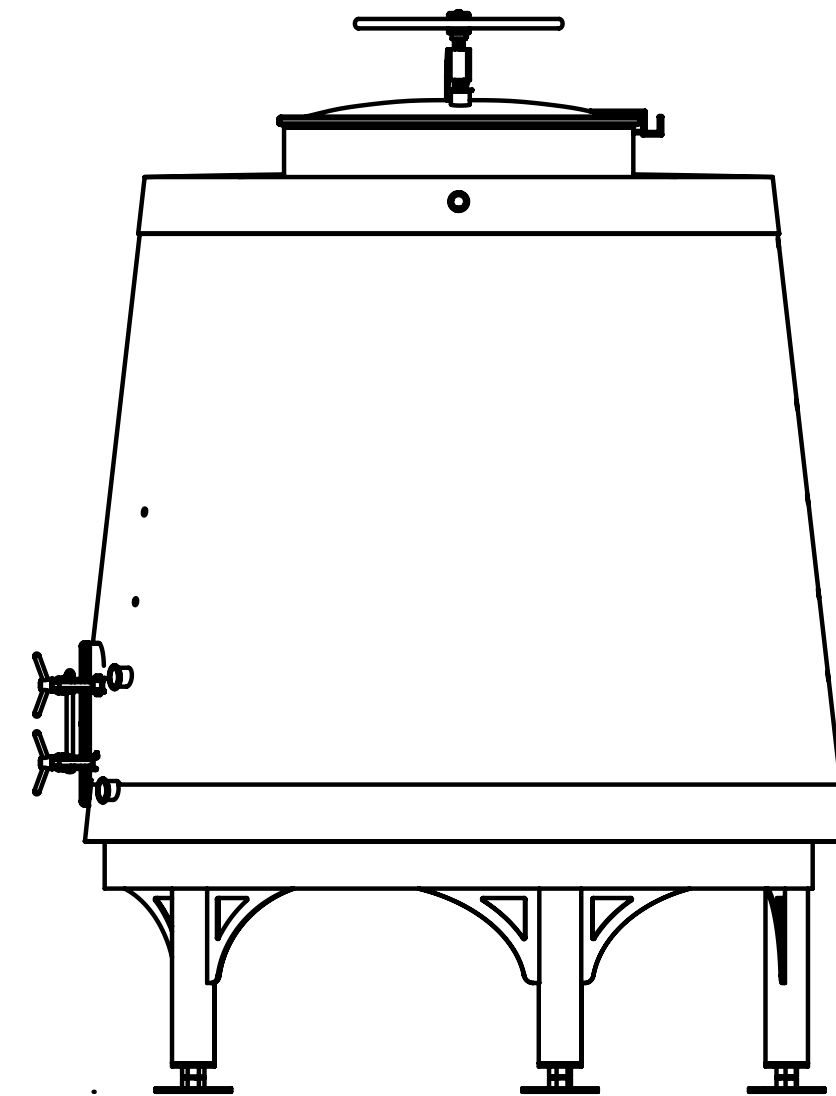

SLOPED TANK BASE CONFIGURATION FOR SLOPED PAD

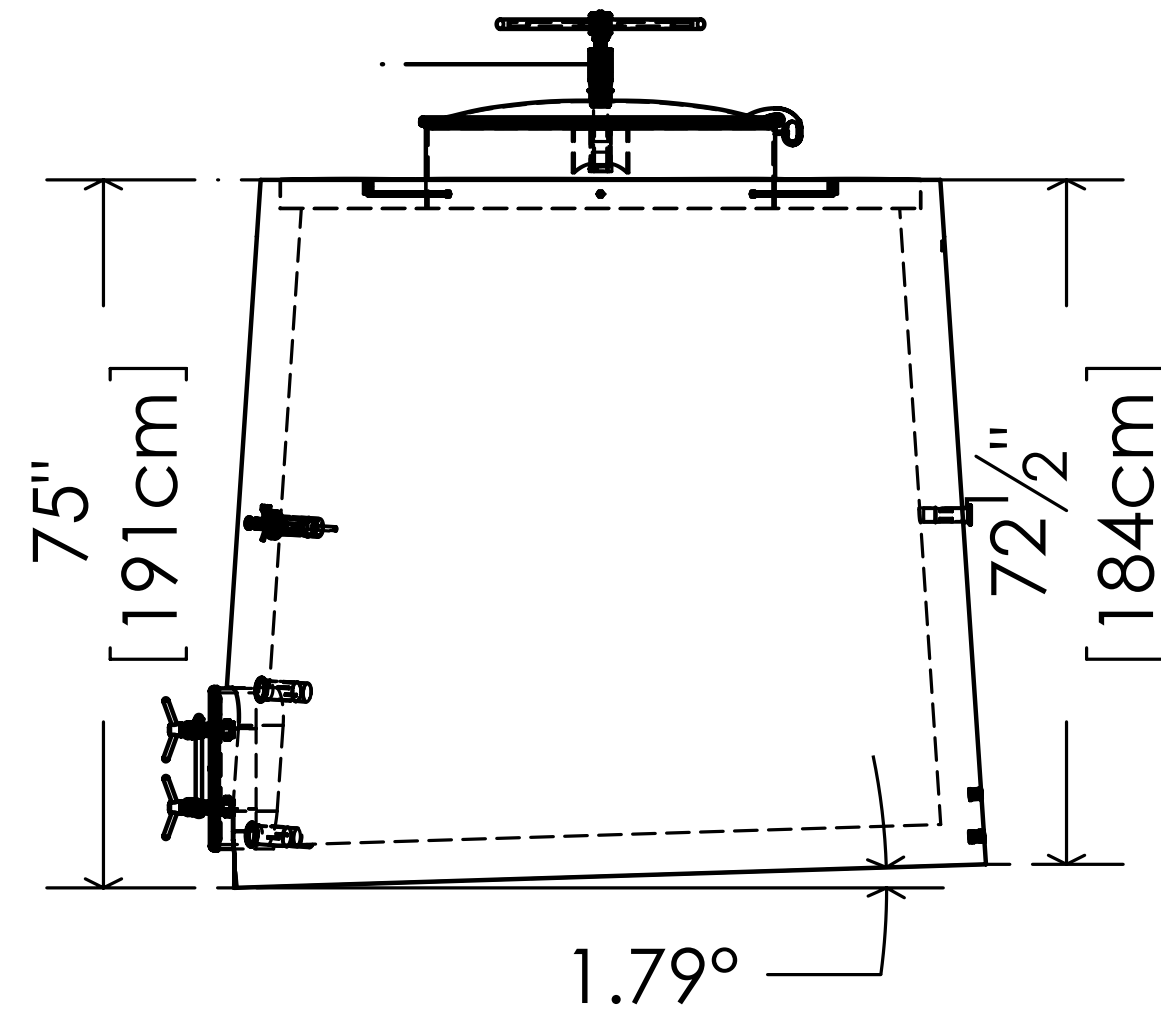
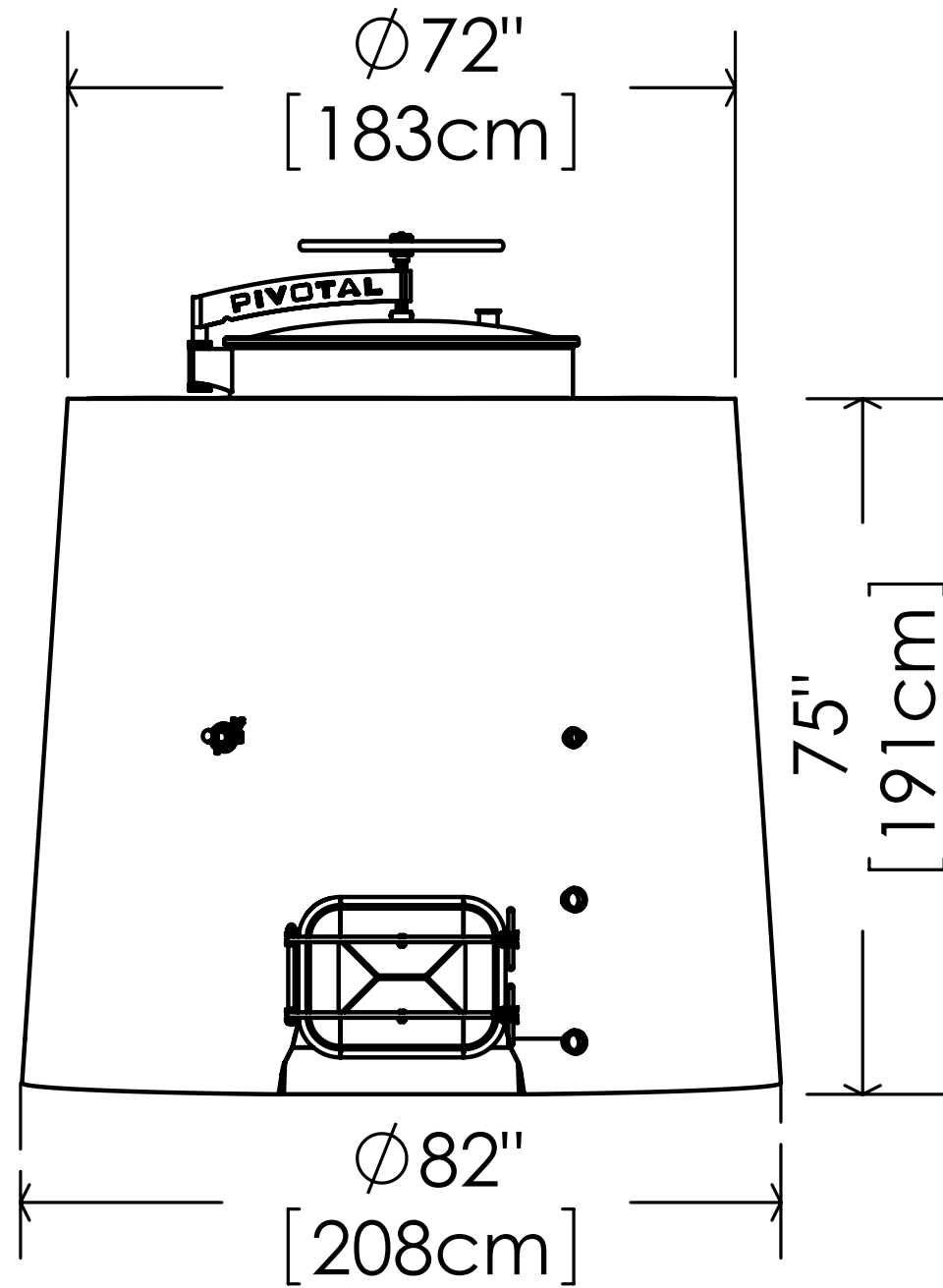

LEVEL TANK BASE CONFIGURATION

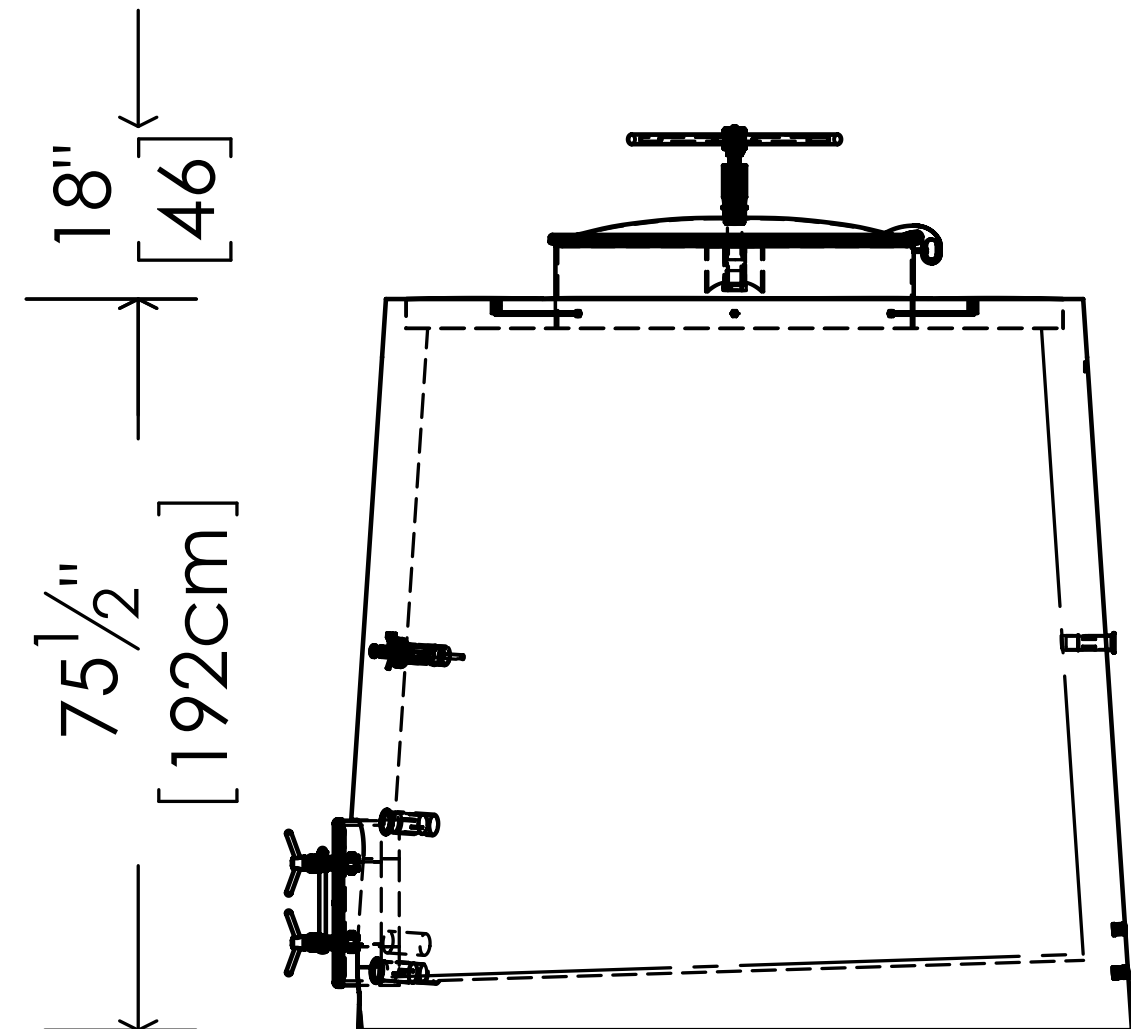
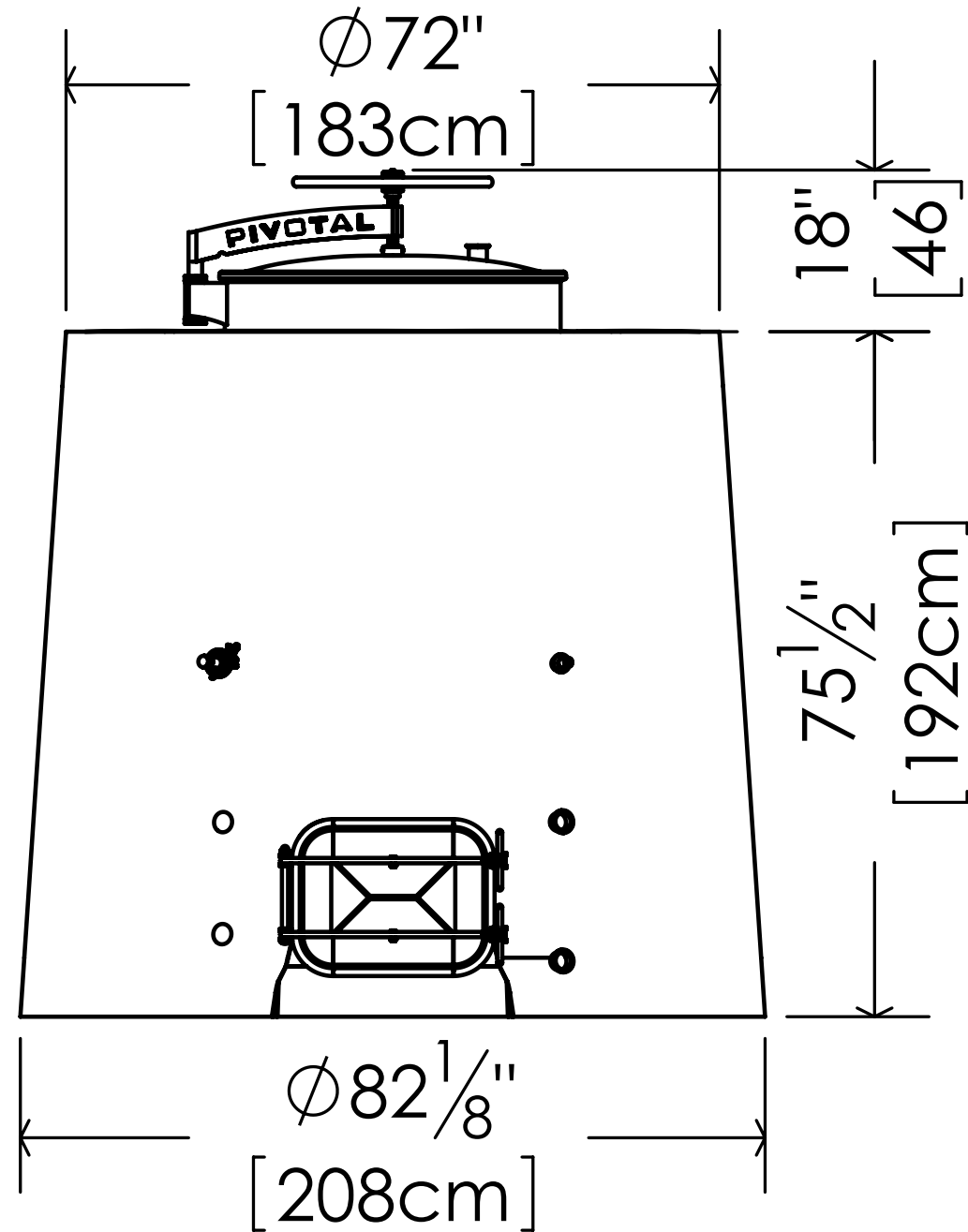

Level Tank Base Configuration

LEVEL TANK BASE CONFIGURATION WITH STAINLESS STEEL OR POWDER-COATED STEEL STAND

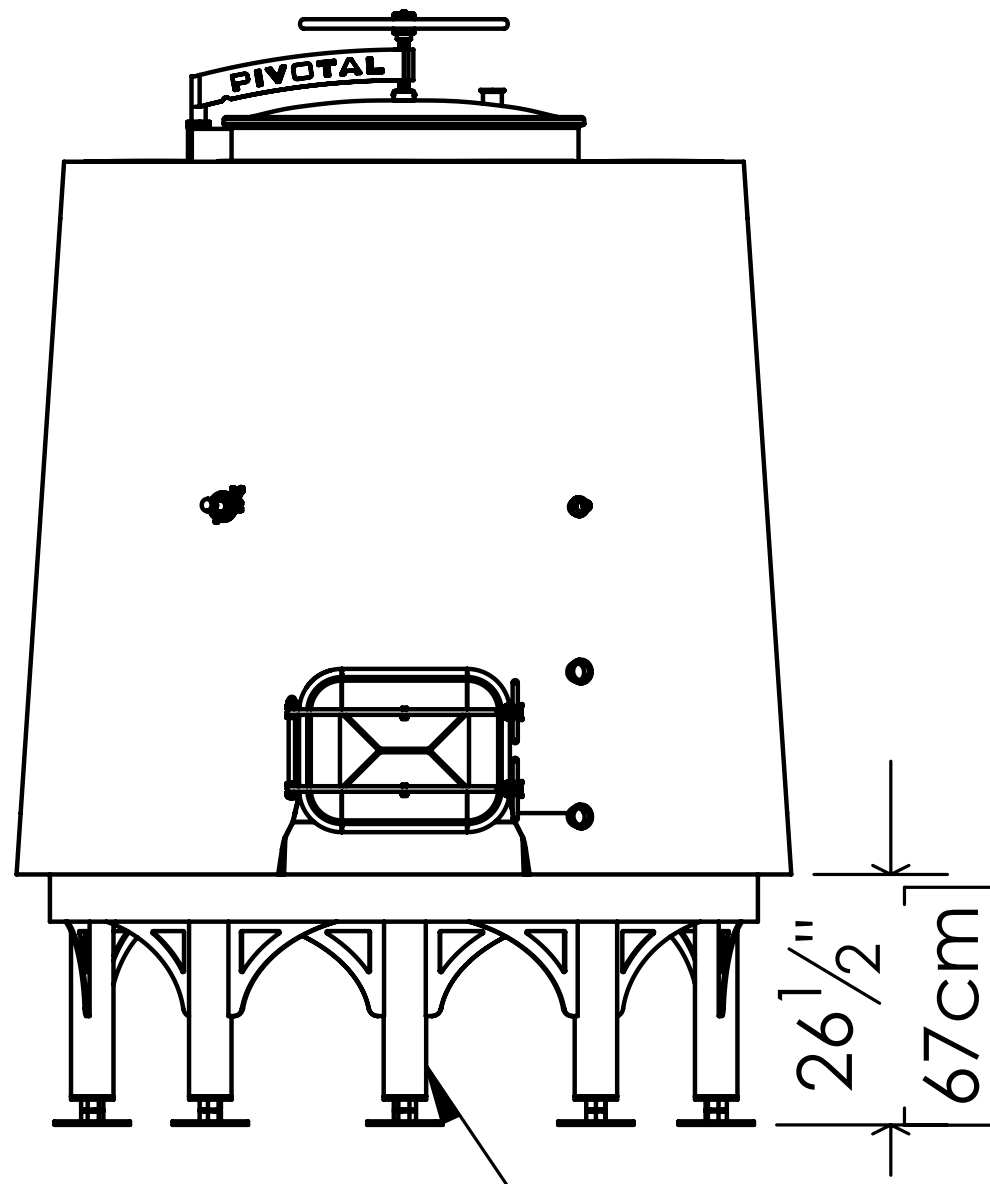

Tubular Leg w/Round Stainless Steel Foot,
Adjustable Height up to 32" Custom Heights Available

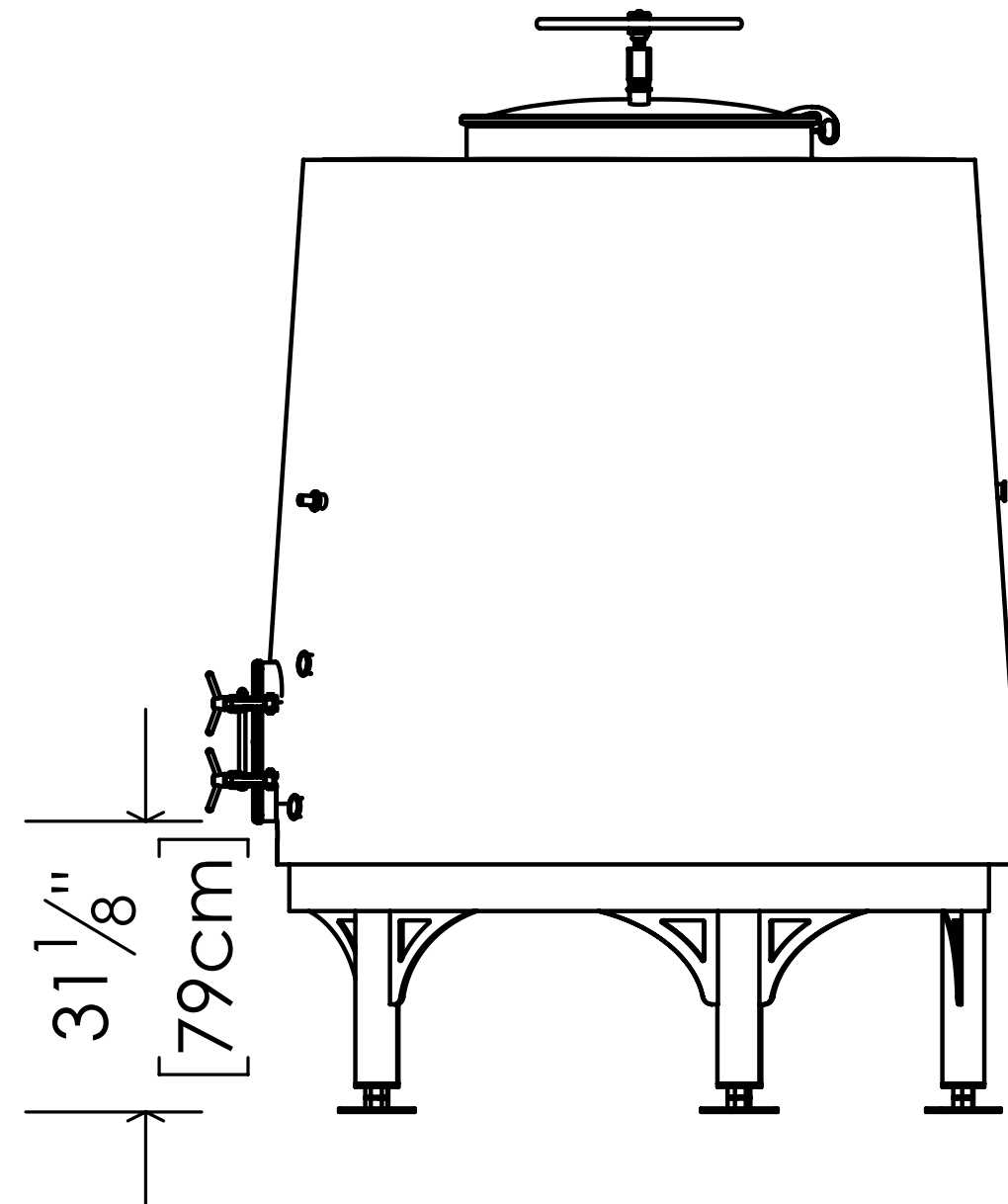



LEVEL TANK BASE CONFIGURATION WITH THREE-PART CONCRETE LEGS

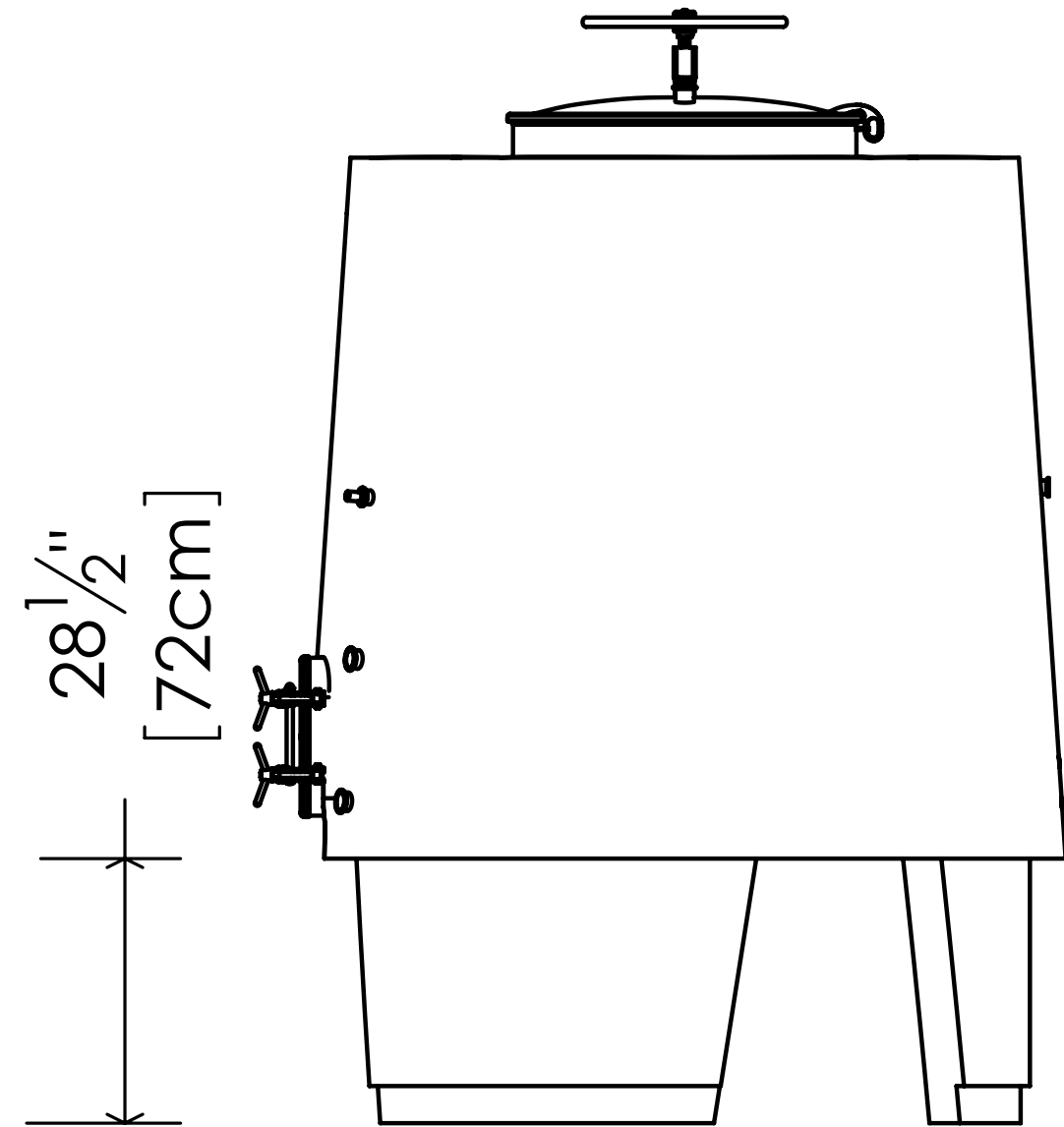
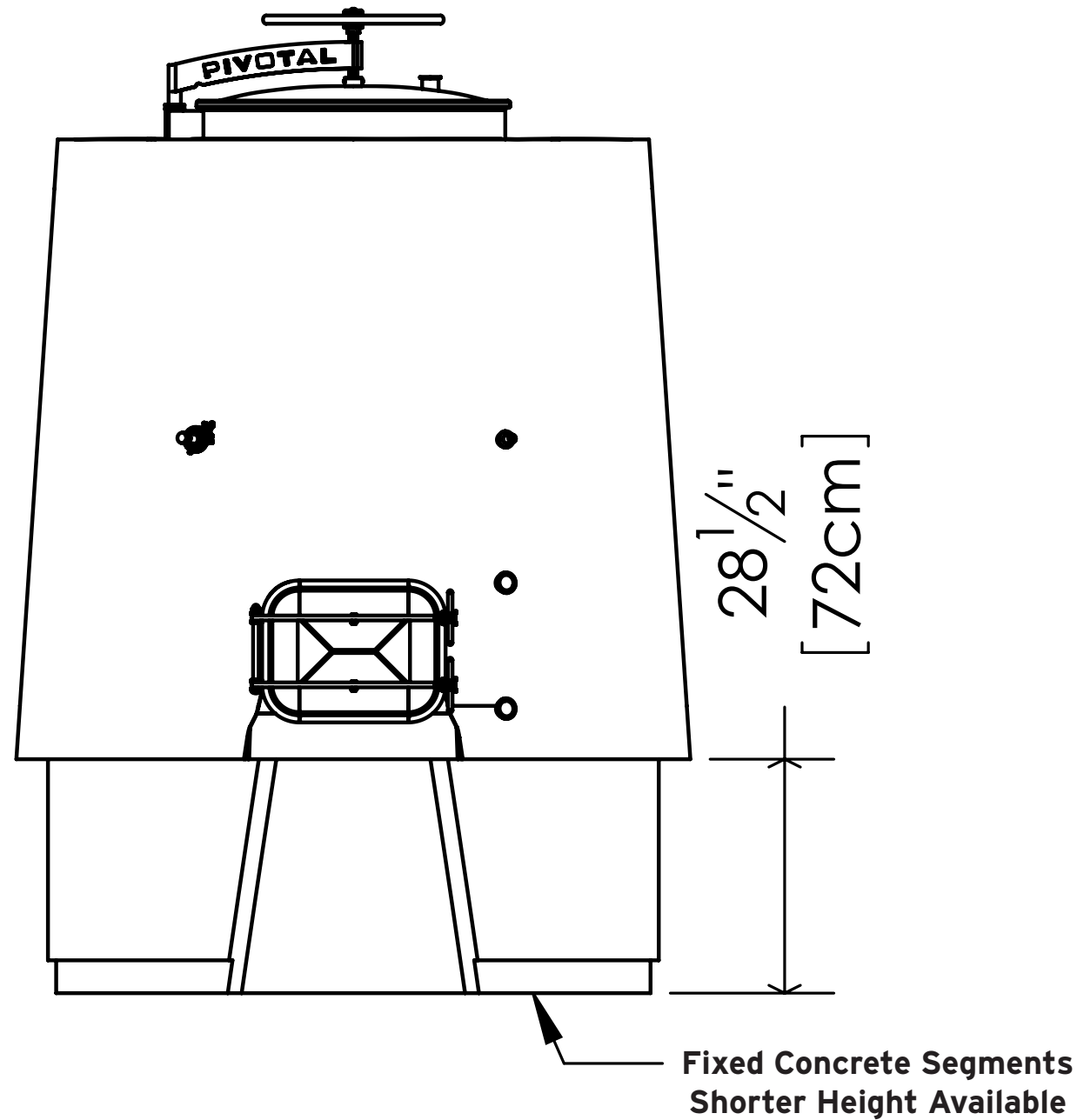



CONICAL ELLIPTICAL

1,011 gal / 5,164 ltr / 38hl

Some items shown here may be optional and not included. Refer to your order.

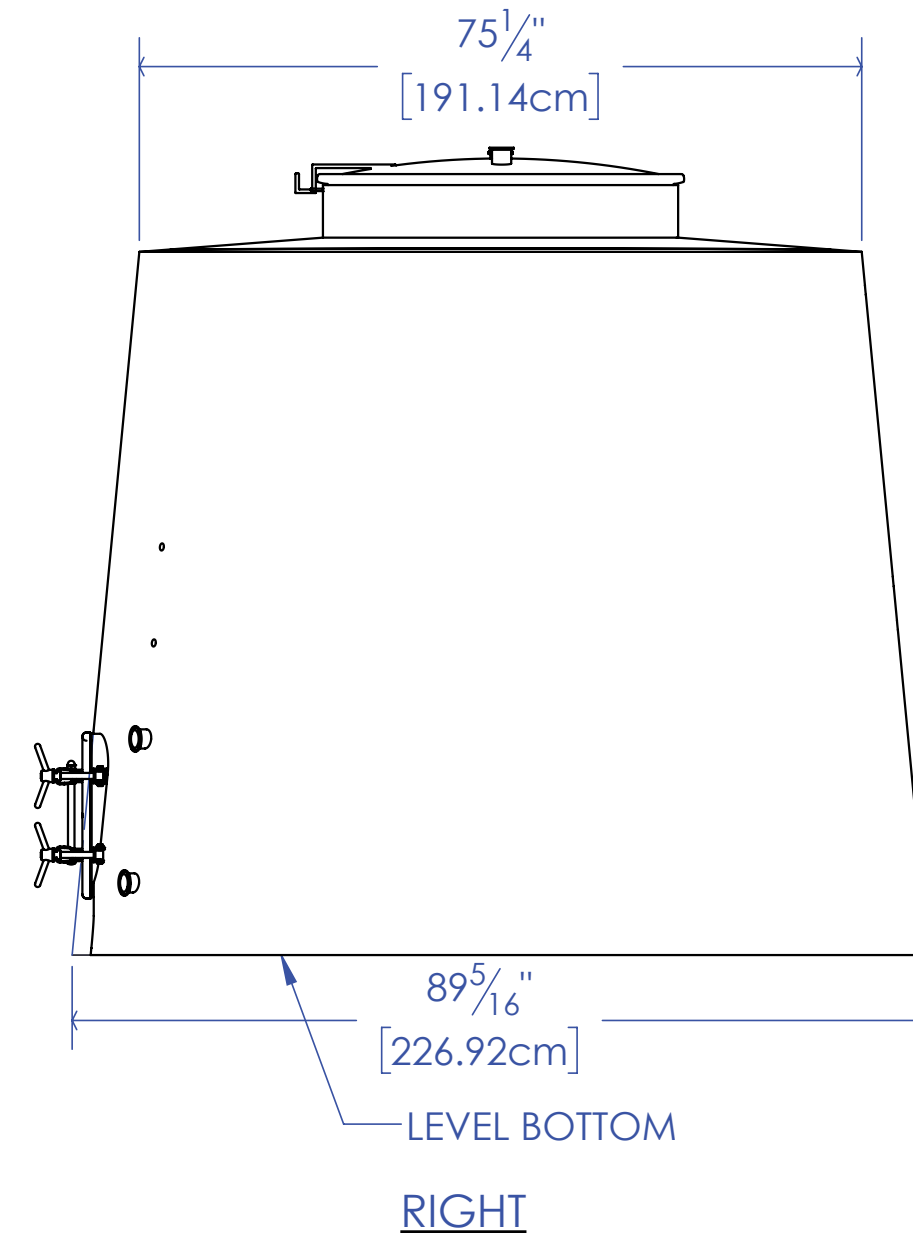
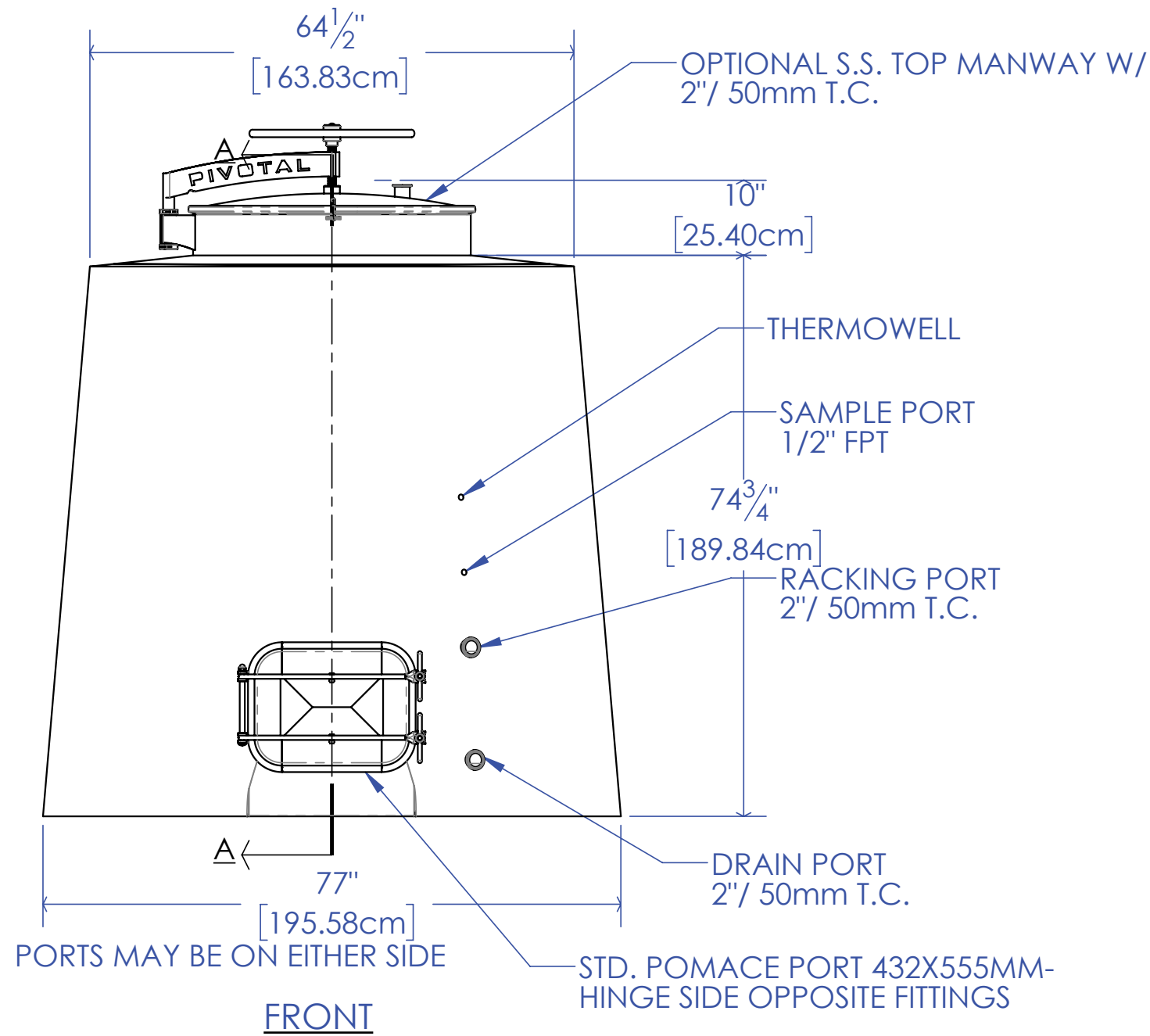



CONICAL ELLIPTICAL

1,011 gal / 5,164 ltr / 38hl

Some items shown here may be optional and not included. Refer to your order.

CAPACITY 1,011 GALLONS/ 3,827L

MAY OMIT CONC.
TOP & MANWAY

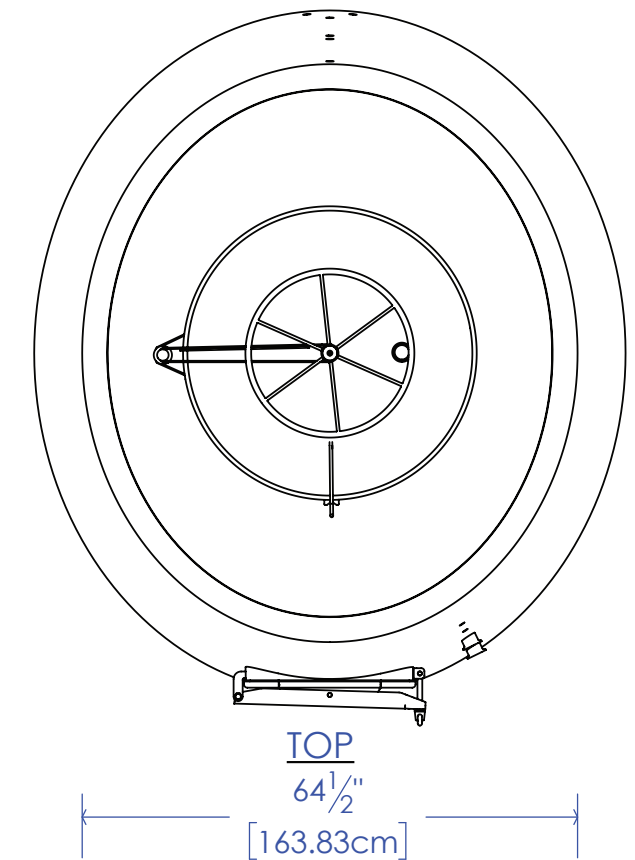
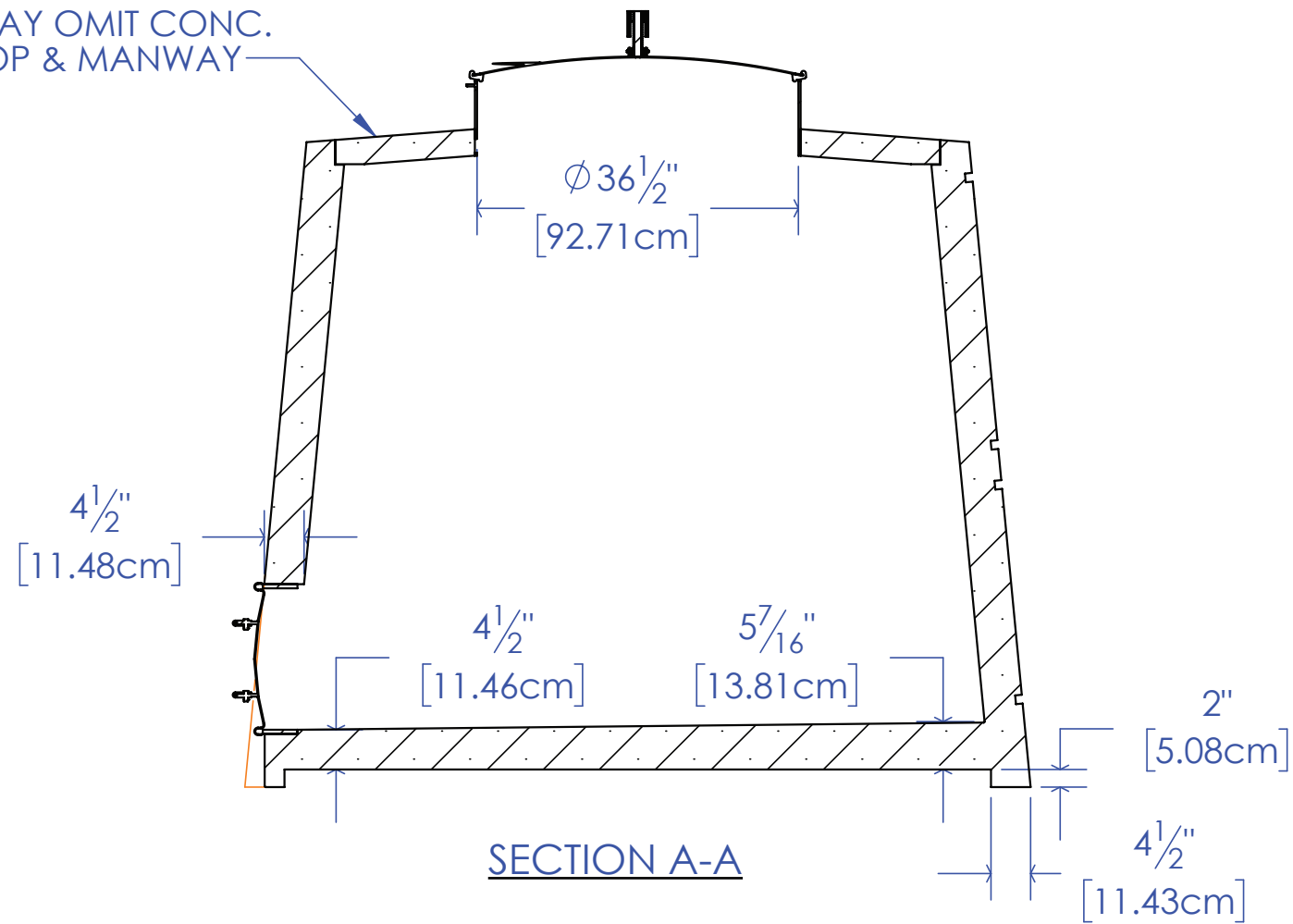



Embedded Glycol System

One of the many advantages of using concrete to ferment and age wine is that concrete tends to stabilize temperatures naturally. To take this advantage of natural stability to the next level, glycol temperature-control systems are employed by winemakers to gain precise and complete control of temperature. With this fabulous tool, you literally set-it-and-forget-it.

And, of course, Sonoma Cast Stone was the first manufacturer to take this next-level technology to a further innovation by embedding the glycol tubes within the wall of the tank itself. In this way, the plumbing of the glycol system is not allowed to make contact with your precious wine. The tubes remain hidden and do not get in the way of cleaning.

The Pivotal Manway Cover

International Patent Pending

A simple choice: you can screw down 10 handles several times a day, you can reach out and lift a 45-pound stainless lid or, and here comes the fun part, you can turn a yacht wheel a few times and with one finger, Pivot the large lid in either direction. No kidding, One Finger. It's a tiny bit shy of magical.

Designed for concrete tanks, but it works equally well on oak and stainless tanks. Next time you order something other than concrete (and we don't see why you would) order it with a Pivotal top and we will ship directly to your tank supplier.



CONCRETE WINE TANKS
SONOMA CAST STONE

Sonoma Cast Stone Beverage Tank Warranty

Concrete tanks made by Sonoma Cast Stone will be free from any structural cracking for a period of ten (10) years. This warranty is a good faith warranty that will repair or replace - at the discretion of Sonoma Cast Stone - any product that does not meet these conditions.

The warranty does not cover damages resulting from negligence, improper care & maintenance, misuse, abuse, acts of nature, unapproved repairs or failure of supporting members. Any replacement excludes all associated removal or re-installation costs. This warranty does not allow recovery of incidental or consequential damages such as loss of use, delay, property or product damage or other consequential damage.

This warranty is limited to the items made by Sonoma Cast Stone. Any damage occurring on third party accessories or attachments will carry that vendor's warranty. Damage sustained in the course of third party shipping is beyond Sonoma Cast Stone's control and will be covered by the responsible shipping company.

Any damage discovered must be reported to Sonoma Cast Stone and the shipping company immediately. This warranty begins at the date of shipment.

Sonoma Cast Stone Corporation

133 Copeland Street Petaluma, CA 94952
(877) 283-2400 fax (707) 283-1899
www.concretewinetanks.com

Pick a color,
any color..



SONOMA CAST STONE
CONCRETE INNOVATIONS

(Including custom blends.)