



# Condensate and Feedwater Systems

Section 7.2

# Learning Objectives

- 1. List in proper flowpath order and state the purpose of the following condensate and feedwater system components:**
  - a. Condenser**
  - b. Condensate (hotwell) pump**
  - c. Demineralizers**
  - d. Low pressure feedwater heaters**
  - e. Main Feed Pumps (MFPs)**
  - f. High pressure feedwater heaters**
  - g. Feedwater control and bypass valves**
  - h. Feedwater Isolation Valves (FWIVs)**
  - i. Steam Generators (SGs)**
  - j. Startup Auxiliary Feedwater AFW pump**
  - k. Heater drain System**
  - l. Condensate Storage Tank (CST)**

# Learning Objectives (cont-2)

- 2. List the components and connections located in the Seismic category I portion of the feedwater system piping, and explain the purpose of each.**
- 3. Explain how cascading heater drains increase plant efficiency.**

# Condensate and Feedwater Systems

The Purposes of the Condensate and Feedwater Systems are:

- To transfer water from the main condenser to the steam generators and to preheat it,
- To collect and distribute the condensation from the feedwater heater drains, and
- To purify secondary water and to maintain secondary chemistry control

Condensate System Fig 7.2-2

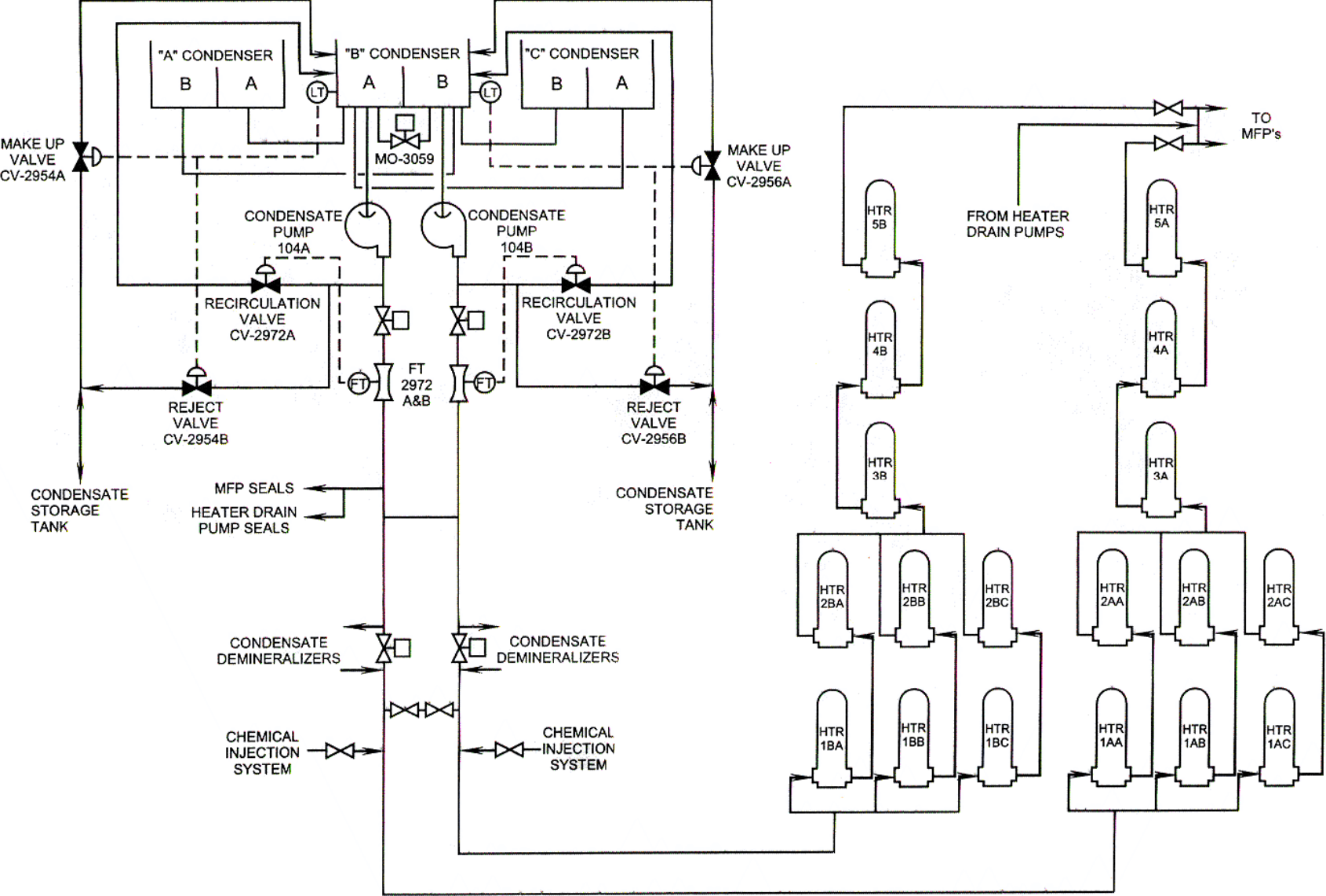

# Main Condenser Objective 1.a

- Purpose - Provides a heat sink to condense the steam exhausted from the three LP turbines, the main feedwater pump turbines, and the Steam Dumps.
- 3 shell, multi-pressure, deaerating, surface condenser.
  - **One condenser connected to each LP turbine.**
  - **Air ejectors maintain vacuum during operations.**
  - **Condensed steam collected in hotwell.**

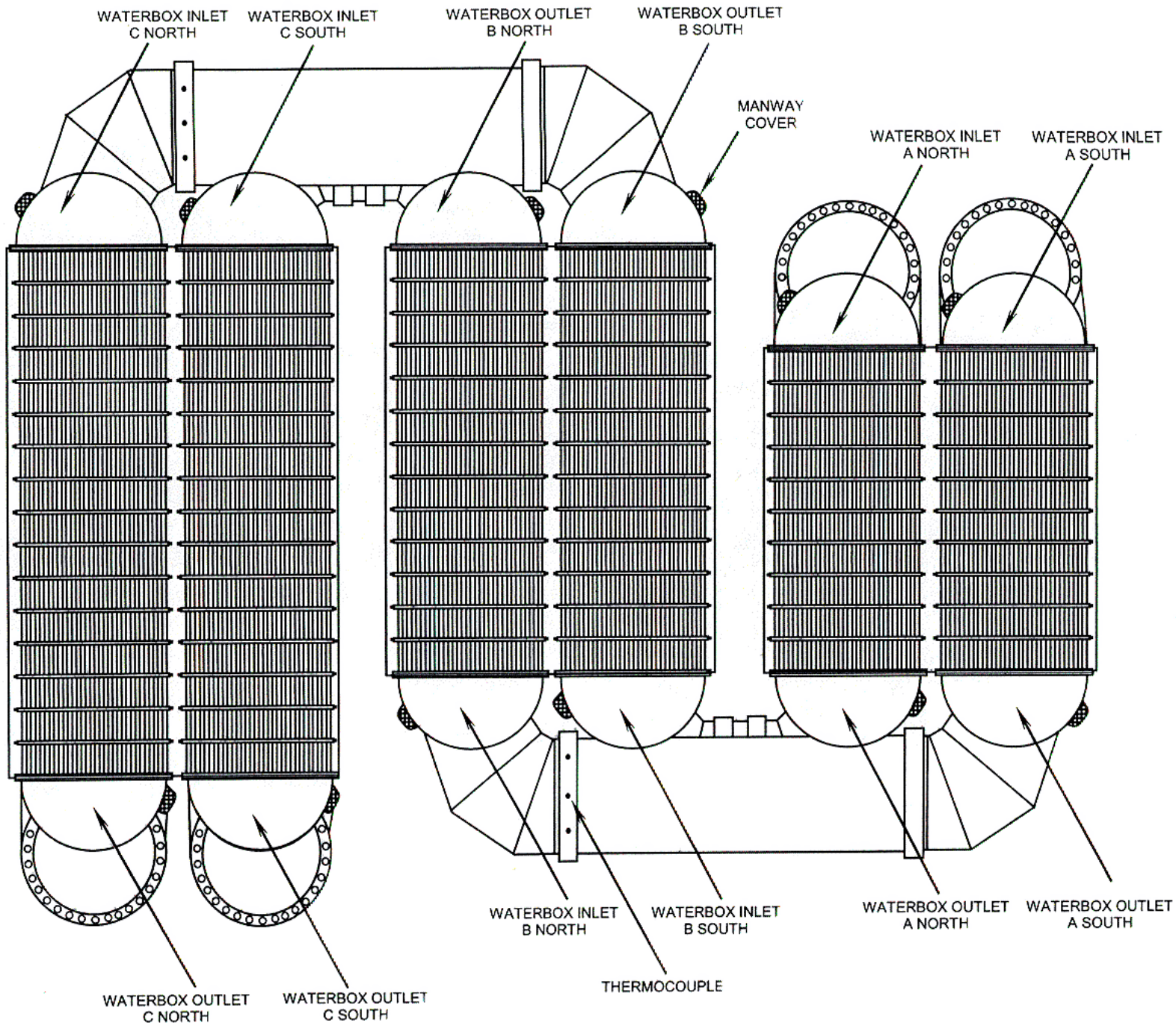

# Condenser Hotwell Objective 1.a

- Purpose - Provides a storage reservoir for condensed steam.
- Hotwell is located in the bottom section of the condenser.
- Condenser Hotwell level control via makeup and rejection connections to the Condensate Storage Tank (CST).



Fig. 7.2-9

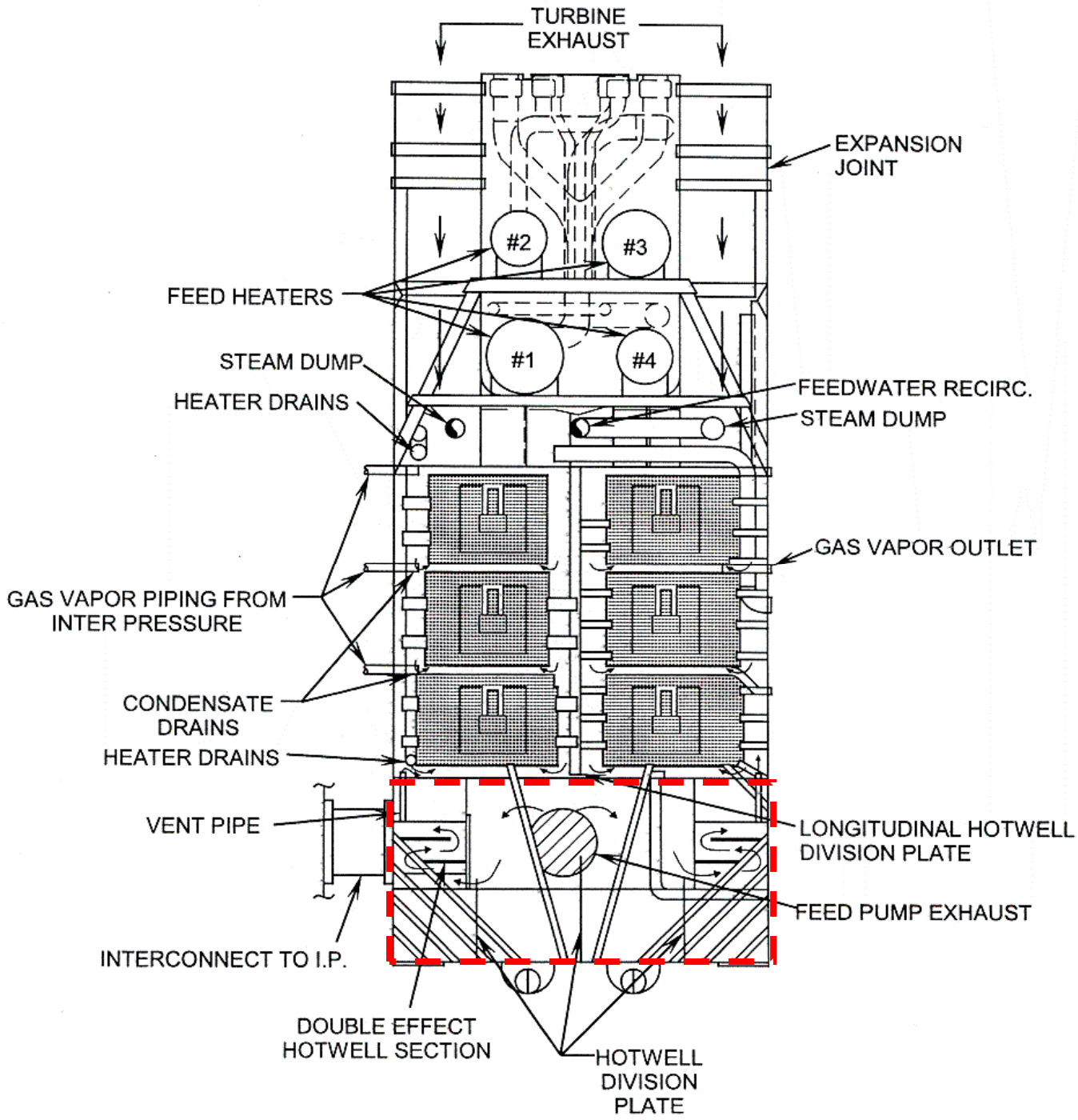

# Condensate Pumps Objective 1.b

- Purpose - Take a suction on their associated hotwell train, raise pressure of condensate & transport it through demineralizers and LP feedwater heaters to the suction of the MFPs.
- 8 stage, vertical, centrifugal pump.
- ~ 4000 HP, ~ 11,000 gpm each, non-vital AC power.
- One pump sufficient for ~ 70% plant power.

# Demineralizer Systems Objective 1.c

- Used for purification and chemistry control of the condensate & feedwater systems during plant S/U.
- During power operations, used for clean up if a contaminant is introduced into the secondary. (e.g. condenser tube leak)

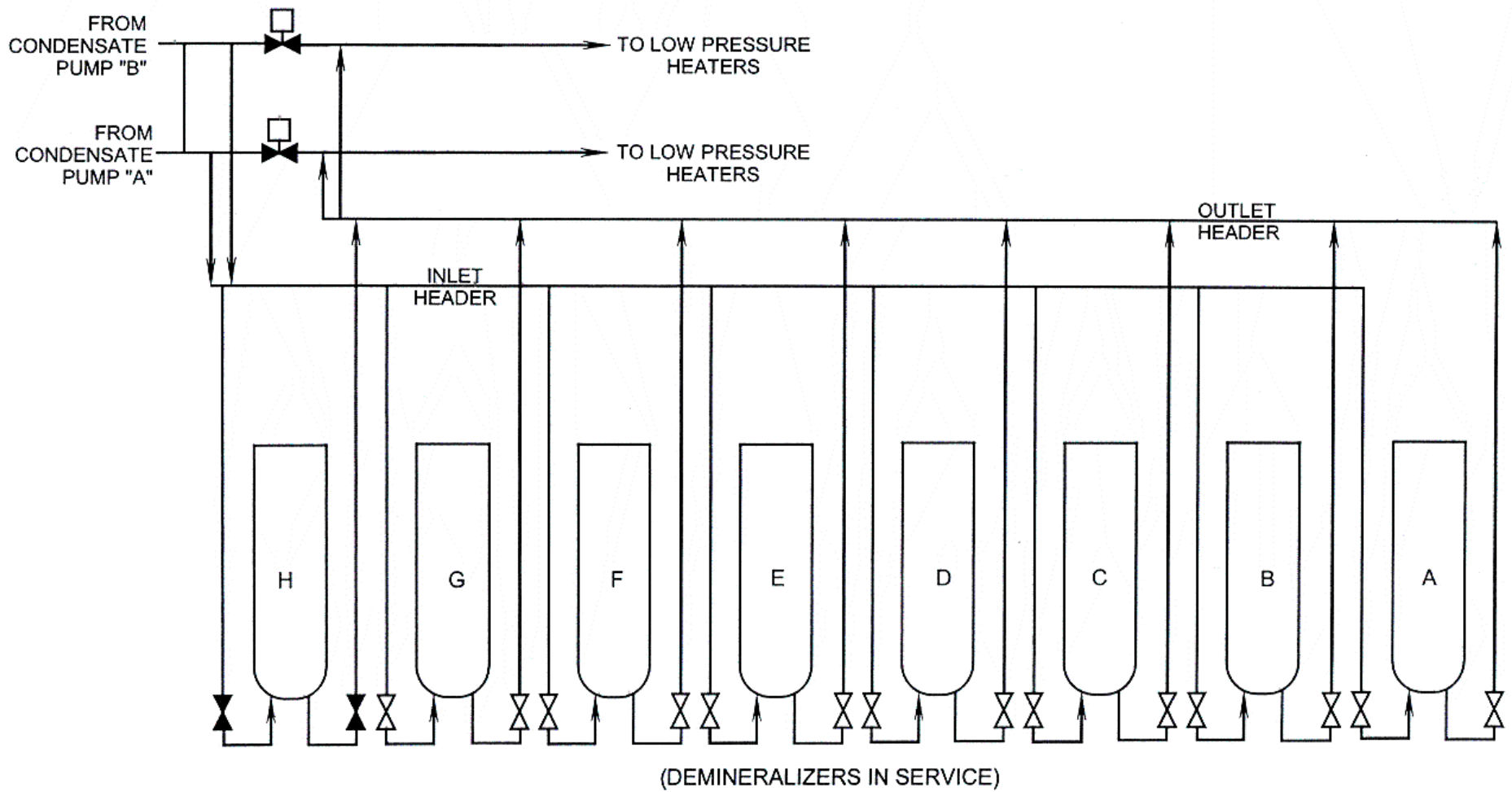

Fig. 7.2-3

# Low Pressure Feedwater Heaters

## Objective 1.d

- Purpose - Transfer heat from turbine extraction steam to the feedwater to improve overall plant efficiency.
- Raise condensate temperature from ~ 120 deg. to ~ 360 deg.
- (LP turbine extraction – Heaters #1 – 4)
- (HP turbine exhaust – Heater #5)
- Heaters # 1 & 2 located in main condenser.

Fig. 7.2-2

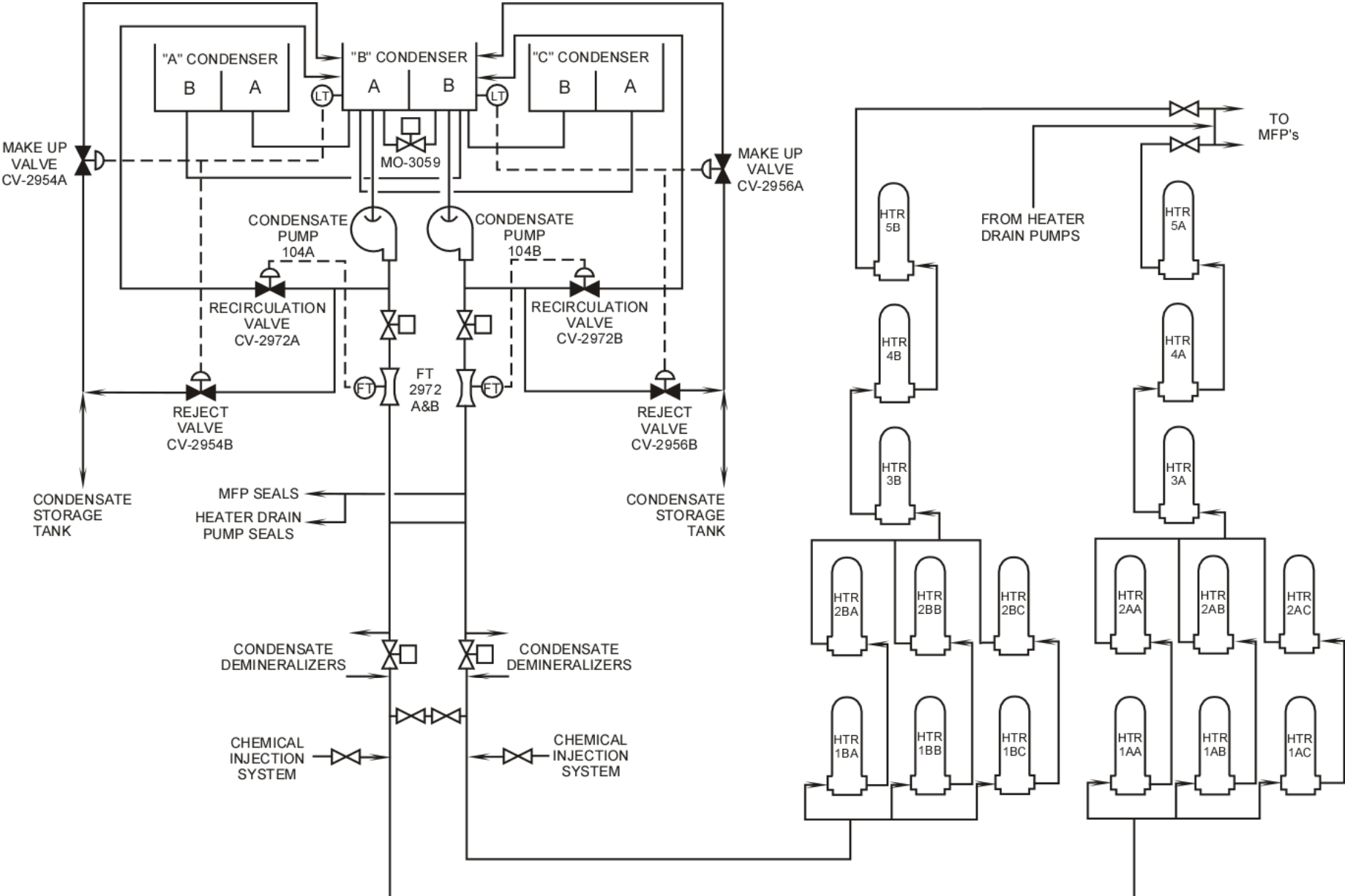

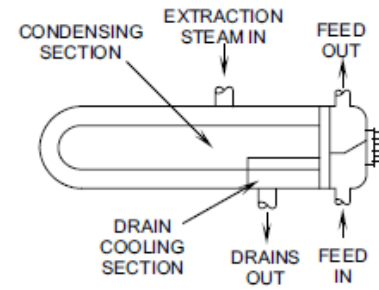
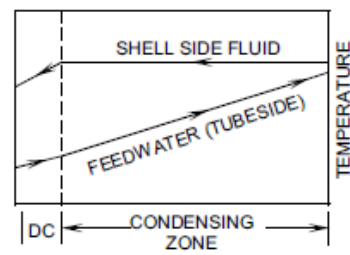
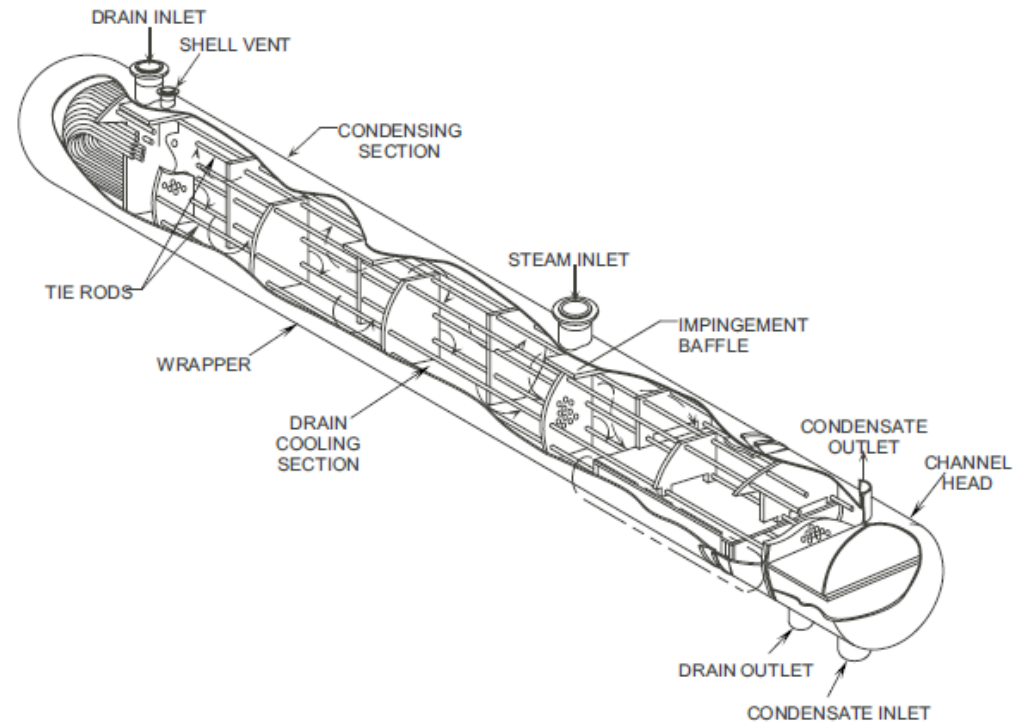

Figure 7.2-4 Feedwater Heater

# Condensate Storage Tank Objective 1.I

- Provides makeup water for the condensate and feedwater system & the primary source of water for the AFW system.



# Feedwater System

## Fig 7.2-5

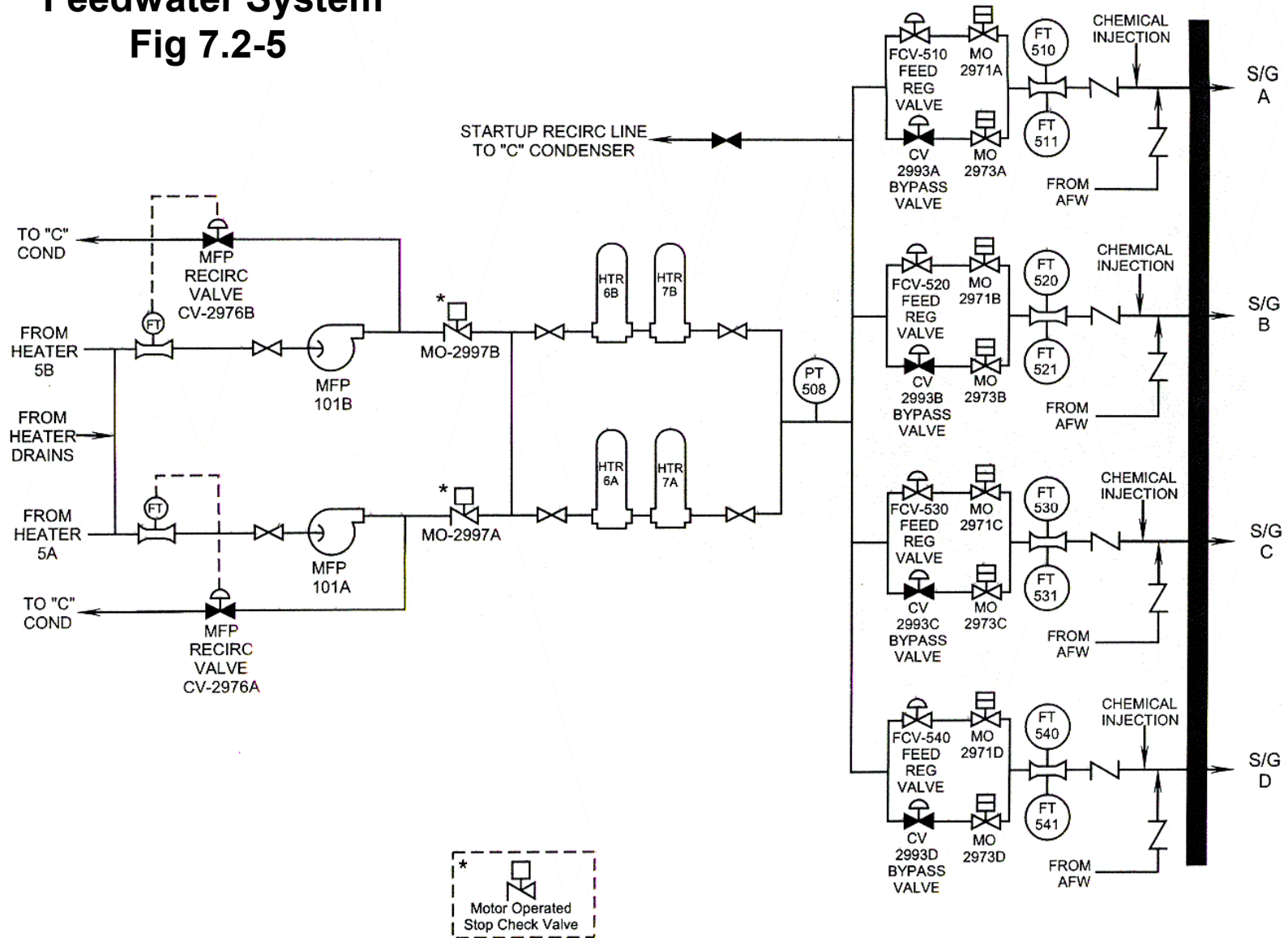

# Main Feedwater Pumps Objective 1.e

- Purpose - Take a suction from Condensate System and the Heater Drain Pumps, raise the pressure of the feedwater, and transport it through the HP feedwater heaters to the S/Gs.

# High Pressure Feedwater Heaters

## Objective 1.f

- Purpose - Transfer heat from HP turbine extraction steam to the feedwater to improve overall plant efficiency.

# Feedwater Control Valves (FRV)

## Objective 1.g

- Also called Feedwater Regulating Valves (14"):
  - Automatically control main feedwater flow to S/Gs > 15% power.
  - Can be manually operated.
  - Air operated.
- Bypass Feedwater Regulating Valves (6"):
  - Used to manually control main feedwater flow to S/Gs < 15% power.
  - Air operated.

# Seismic Category I Piping

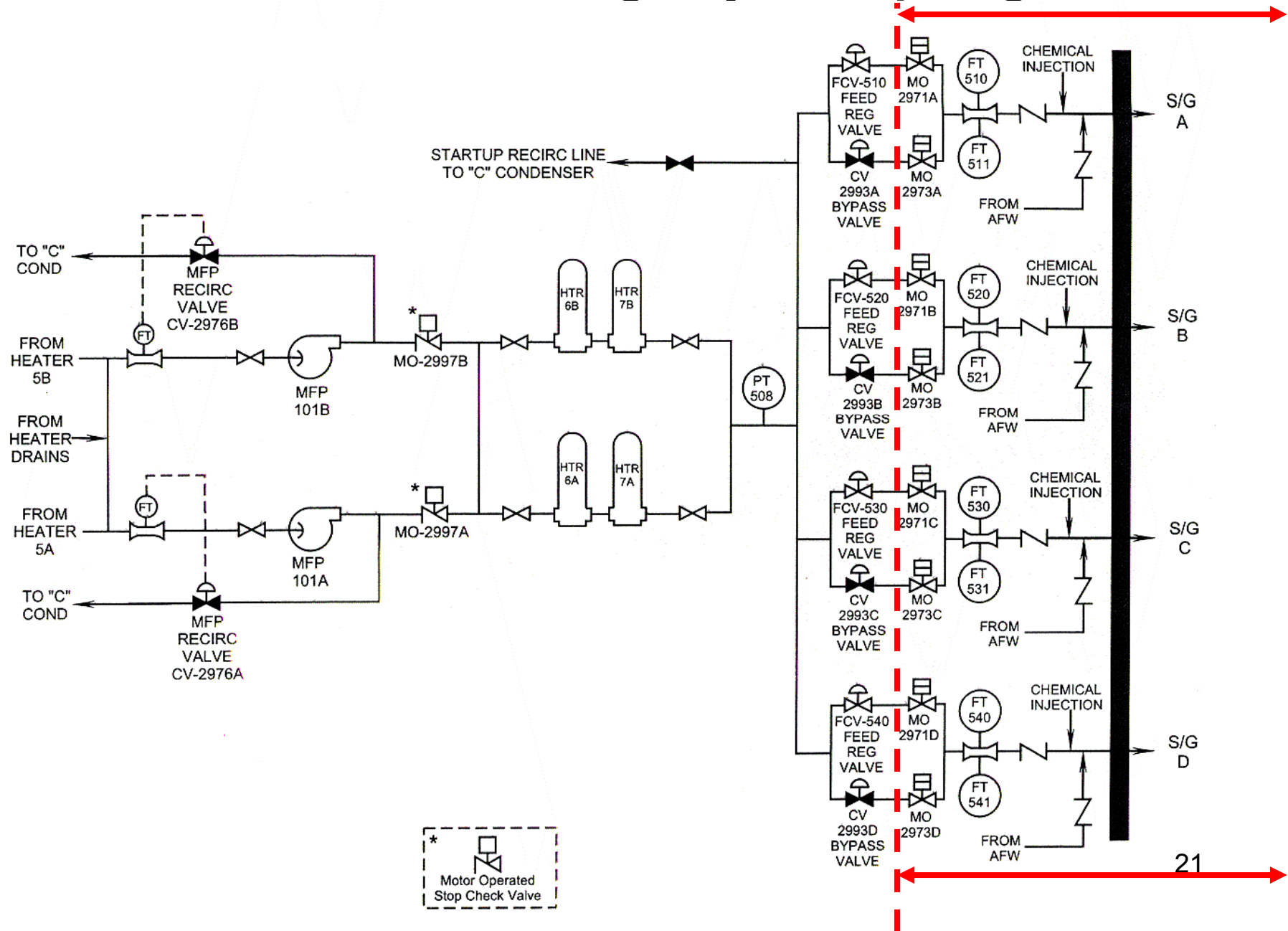

# Feedwater Isolation Valves (FWIV)

## Objective 1.h

- Automatically isolates main feedwater to the S/Gs to prevent excessive cooldown of the RCS.
- Hydraulically operated gate valve – one for each FRV & bypass valve.
- Seismic Category I
- Auto close on feedwater isolation signals:
  - **SI signal**
  - **High High S/G level (> 69%) (P-14)**
  - **Rx trip (P-4) and Low Tave (2/4 < 564 deg.)**

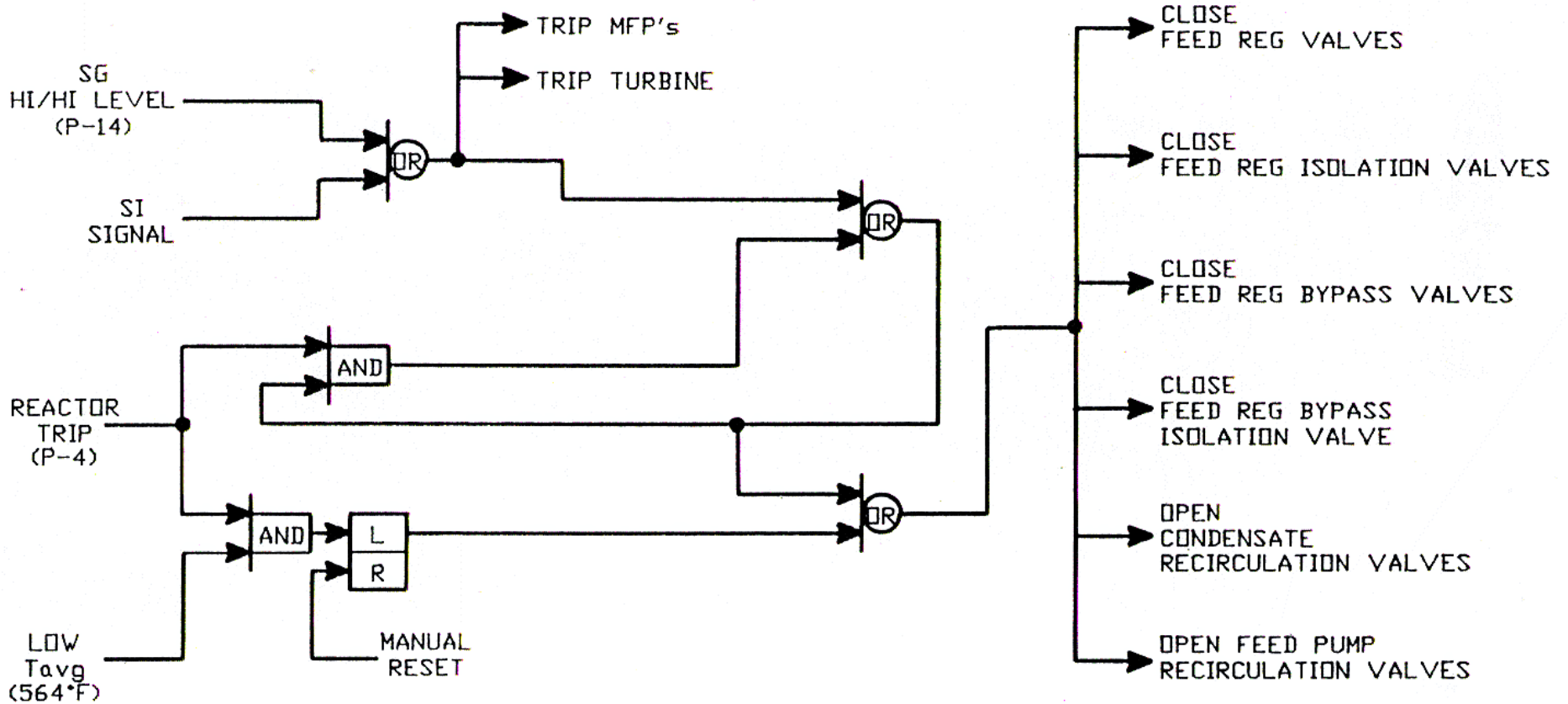

# Feedwater Isolation Logic

# Other Seismic Cat I Components

## Objective 2

- Flow venturi with two flow transmitters:
  - provides feedwater flow signal to Feedwater Control System and Rx Protection System.
- Check valve: prevents the loss of S/G inventory from a feedwater system break upstream of the check valve.
- Chemical Injection Connection: for chemical addition to the S/Gs when plant is S/D.
- AFW Connection: provides a flow path for AFW to the S/Gs to remove decay heat.



# Startup Auxiliary Feedwater Pump

## Objective 1.j

- Provides feedwater flow to the S/Gs during normal startups & shutdown periods when main steam and MSR steam are not available.

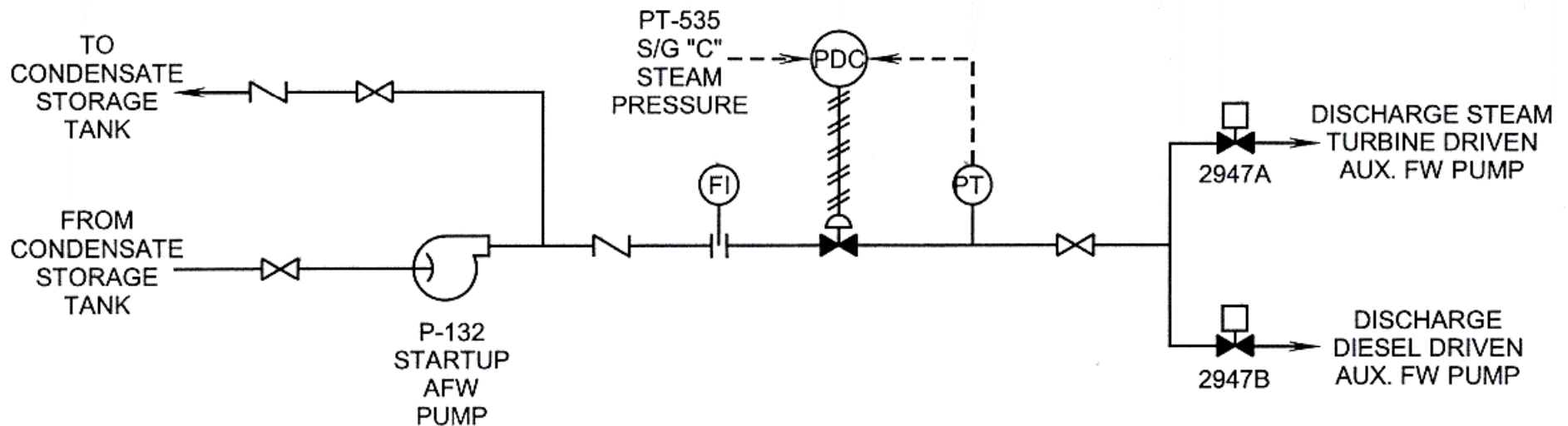

# Steam Generators Objective 1.i

- Transfer energy from the primary to the secondary to produce dry, saturated steam for use in the main steam system.
- Provide a boundary between the primary and the secondary (U-tubes).

**Fig 7.2-6  
Heaters & Drains**

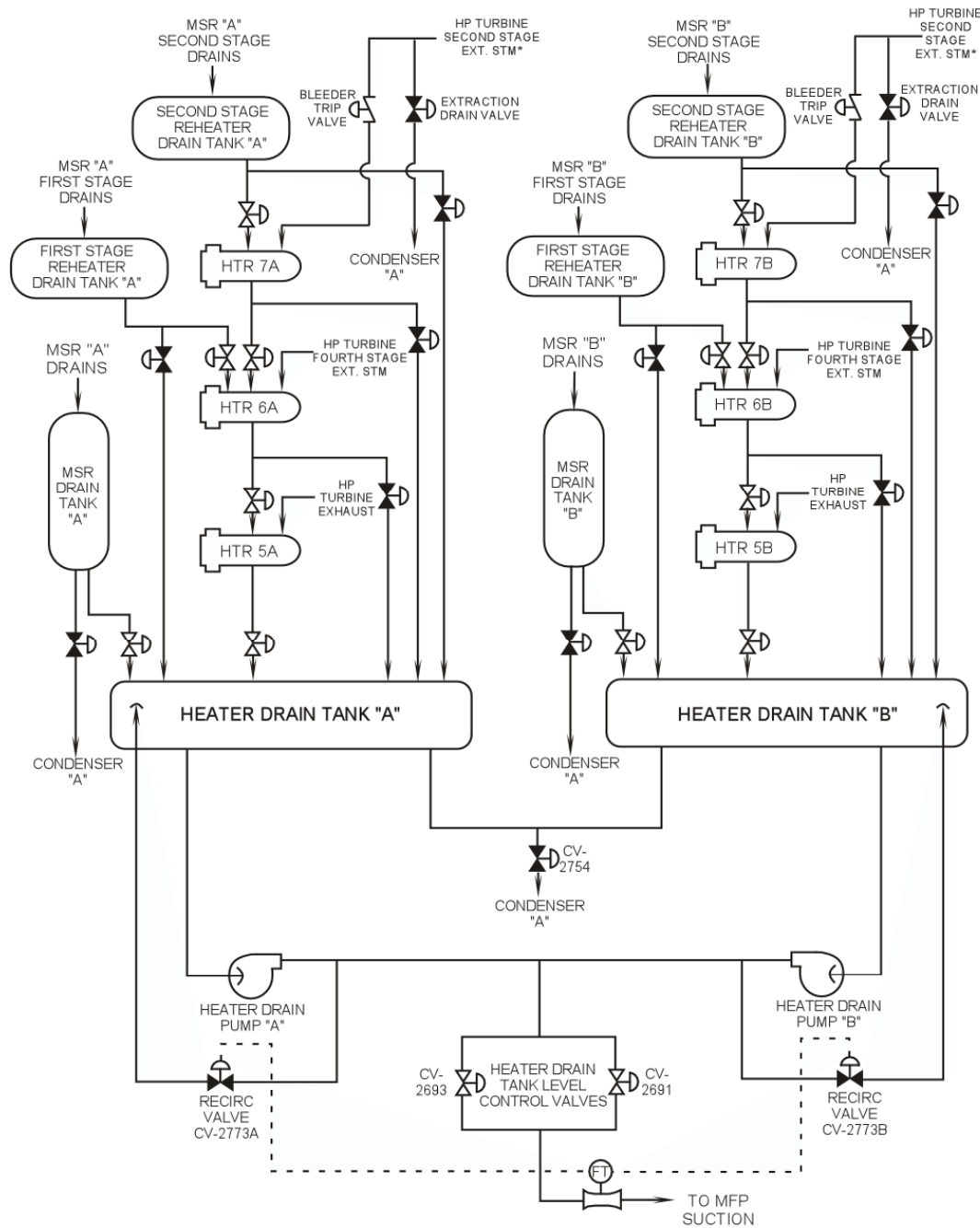

\*EXTRACTION STEAM SUPPLY AND DRAIN ARRANGEMENT TO EACH HEATER IN THIS FIGURE IS SIMILAR TO THAT SHOWN FOR HEATERS 7A & 7B. THE ARRANGEMENT IS NOT REPEATED FOR SIMPLICITY.

# Heater Drain System Objective 1.k

- Collects condensed steam from MSRs and from high & low pressure feedwater heaters.
- Returns condensed steam from MSRs & HP FW HTRS to Heater Drain Tanks.
- Heater Drain Pumps supply suction of MFPs.
  - HDPs supply ~ 1/3 of the total suction flow to MFP.
- Returns condensed steam from LP FW HTRS to condenser.

# Cascading Heater Drains Objective 3

- Improves secondary plant efficiency by allowing the repeated use of relatively hot water (condensed extraction steam) for FW heating.

Fig. 7.2-7

