



Condensing Unit Installation and Maintenance

Bulletin T40-TCU-IM-20
Part # 1068156

PRODUCT SUPPORT
 web: www.t-rp.com/support
 see inside back cover for more details

scan:

Air, Water and Remote Models
Hermetic, Semi-Hermetic and Scroll Compressors

WARNING: Only a qualified refrigeration mechanic who is familiar with refrigeration systems and components, including all controls, should perform the installation and start-up of the system.

CONTENTS

	Page
General Safety	2
Inspection.....	2
Handling, Placement and Installation.....	3
Location.....	4 - 6
Lifting.....	7
Electrical Information.....	8 - 9
Refrigerant Piping	10 - 12
Line Insulation.....	13
Valve Systems.....	14
Refrigerant Charging	14 - 19
Weight Of Refrigerants.....	20
Compressor Oils.....	21
Water Cooled Condensers.....	22
Recommended Options.....	22
Available Options and Option Information.....	23 - 26
Leak Testing	27
Evacuation and Dehydration	27
Dehydration Procedure.....	28 - 29
System Start-Up Checklist	29
Pressure Controls	30
Low Temperature Room Pull-Down	30
Checking Superheat	31
Sequence Of Operation.....	32
System Operational Checklist	33
System Troubleshooting	34 - 36
Customer Instructions	37
Maintenance Program	37
Service Parts Availability.....	37
<i>Appendix A: Wiring Diagrams.....</i>	<i>A1 - A17</i>
<i>Appendix B: Refrigerant Line Sizing Charts.....</i>	<i>B1 - B5</i>
<i>Appendix C: Equipment Start-Up Sheets.....</i>	<i>C1 - C4</i>
Product Support Resources.....	70 -71
"As Built" Service Parts List.....	BACK

GENERAL SAFETY

IMPORTANT SAFETY NOTE

Only a qualified refrigeration mechanic who is familiar with refrigeration systems and components, including all controls should perform the installation and start-up of the system. To avoid potential injury, use care when working around coil surfaces (if applicable) or sharp edges of metal cabinets. All piping and electrical wiring should be installed in accordance with all applicable codes, ordinances and local by-laws.

WARNING

Always **disconnect and lock off** the main power supply on any system that will be worked on to avoid accidental start up of the equipment.

INSPECTION

Inspect all equipment before unpacking for visible signs of damage or loss. Check shipping list against material received to ensure shipment is complete.

IMPORTANT: Remember, you, the consignee, must make any claim necessary against the transportation company. Shipping damage or missing parts, when discovered at the outset, will prevent later unnecessary and costly delays. **If damage or loss during transport is evident, make claim to carrier, as this will be their responsibility, not that of the manufacturer.**

Should carton be damaged, but damage to equipment is not obvious, a claim should be filed for "concealed damage" with the carrier.

IMPORTANT: Check the electrical ratings on the unit to make sure they correspond to those ordered and to electrical power available at the job site. Save all shipping papers, tags, and instruction sheets for reference by installer and owner.

HANDLING, PLACEMENT AND INSTALLATION

IMPORTANT: When selecting a location for the condensing unit, consideration should be given to some of the following:

- (a) Loading capacity of the floor or roof. Check building codes for weight distribution requirements.
- (b) Distance to suitable electrical supply.
- (c) Distance to the evaporator.
- (d) Adequate air circulation and ventilation.
- (e) Close proximity to water source and floor drains (water-cooled units)
- (f) Accessibility for maintenance.
- (g) Local building codes.
- (h) Adjacent buildings relative to noise levels.
- (i) Wishes of the end user / owner.

When all of the above points have been considered and a specific location chosen, it is advisable to obtain written approval of this location from the building and/or condensing unit owner. This may be a means of avoiding disagreement and expense at a later date.

A fully qualified and properly equipped crew with the necessary tackle and rigging should be engaged to locate the condensing unit in position. When lifting the unit, spreader bars and chafing gear should be used to prevent damage.

The unit should be placed on a base, which is level and even. Units should be lagged to sleepers or support base. Place unit where it will not be subject to damage by traffic or flooding. On critical installations where noise is liable to

be transmitted through the floor structure, vibration isolators should be installed. Isolators should be installed under mounting base and may be rubber or cork or equal.

DO NOT USE THE SHIPPING SKID AS A PERMANENT BASE.

The condensing unit should be positioned to allow adequate space for performing service work.

Indoor and outdoor air-cooled condensing units should be positioned using the guidelines shown below.

Units equipped with spring-mounted compressors have shipping spacers that are designed to hold the compressor rigidly during transit to prevent possible damage. Before operating the unit, it is necessary to remove these spacers. To remove the shipping spacers, follow these steps:

- (a) Remove the upper nuts / washers.
- (b) Discard the shipping spacers.
- (c) Install the rubber cone washers (located in the electrical box).
- (d) Replace the upper mounting nuts / washers.
- (e) Allow 1/16 inch space between the mounting nuts / washers and the compressor foot.

On units equipped with rigid mounted compressors, check the compressor mounting bolts to insure they have not vibrated loose during shipping.

LOCATION: Horizontal Air Flow Condensers and Condensing Units

WALLS or OBSTRUCTIONS

Coil side of the unit must be be 1 condenser coil height away from any wall or obstruction.
Air discharge side obstructions are not permitted.
If enclosed by three walls, 1 condenser coil width must be provided at each end (See multiple units)

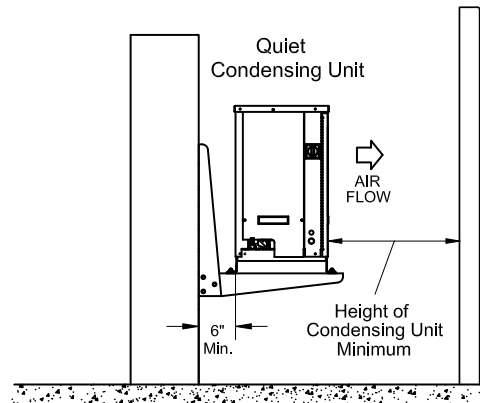
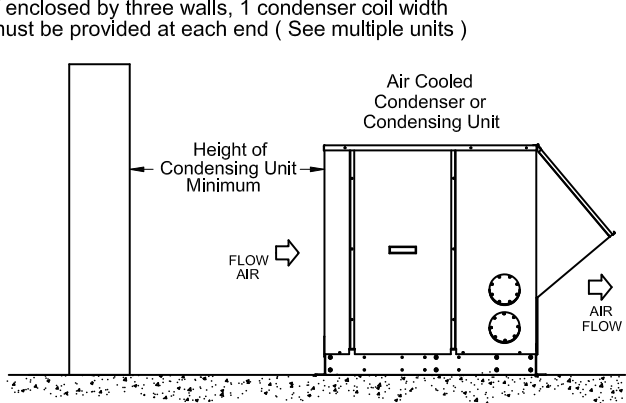

MULTIPLE UNITS

A minimum of 1 condensing unit width must be allowed between units placed side by side.

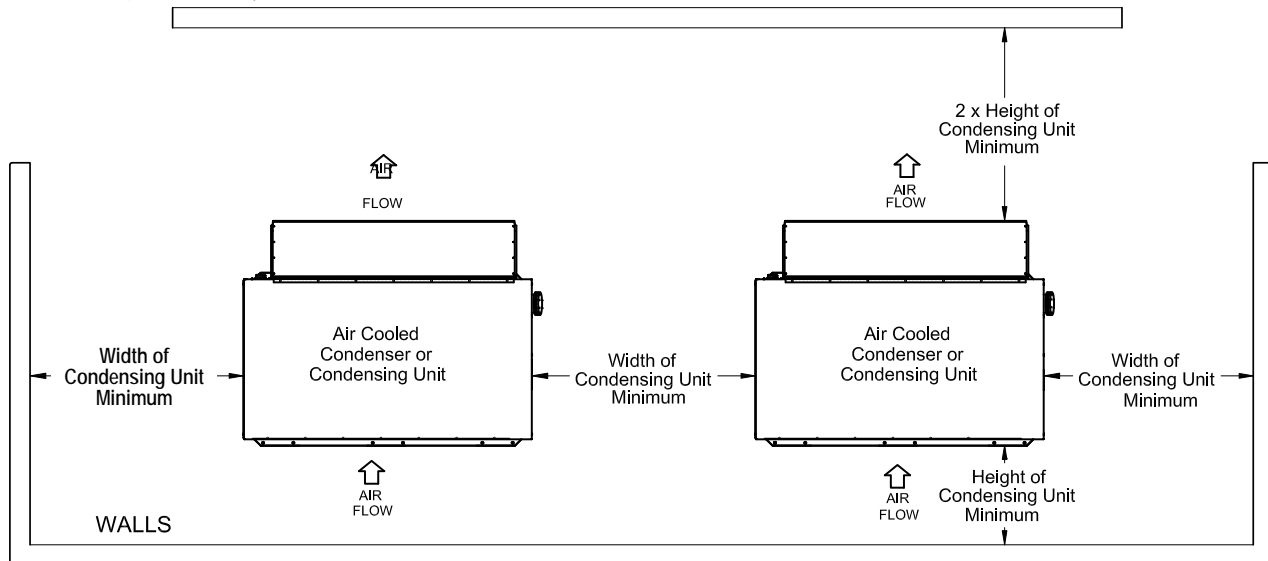

BACK TO BACK UNITS

If placed back to back the minimum spacing is 2 times the tallest Condenser height.

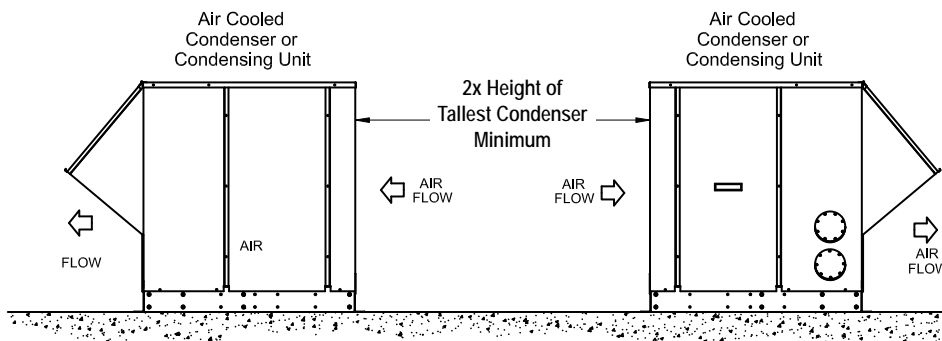

WIND GUARDS

For horizontal air flow models placed in locations open to strong wind blasts, wind guards are available to buffer air flow across the coil to help maintain desired head pressures. Typically applied with variable speed motors when no head pressure control valves are used.

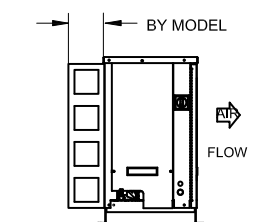

LOCATION: Vertical Air Flow Condensing Units

WALLS or OBSTRUCTIONS

All sides of the unit must be 1 condensing unit width away from any wall or obstruction. Overhead obstructions are not permitted. If enclosed by three walls, the condensing unit must be installed as indicated for units in a pit.

MULTIPLE UNITS

A minimum of 2 condensing unit widths must be allowed between units placed side by side.

Coil End View

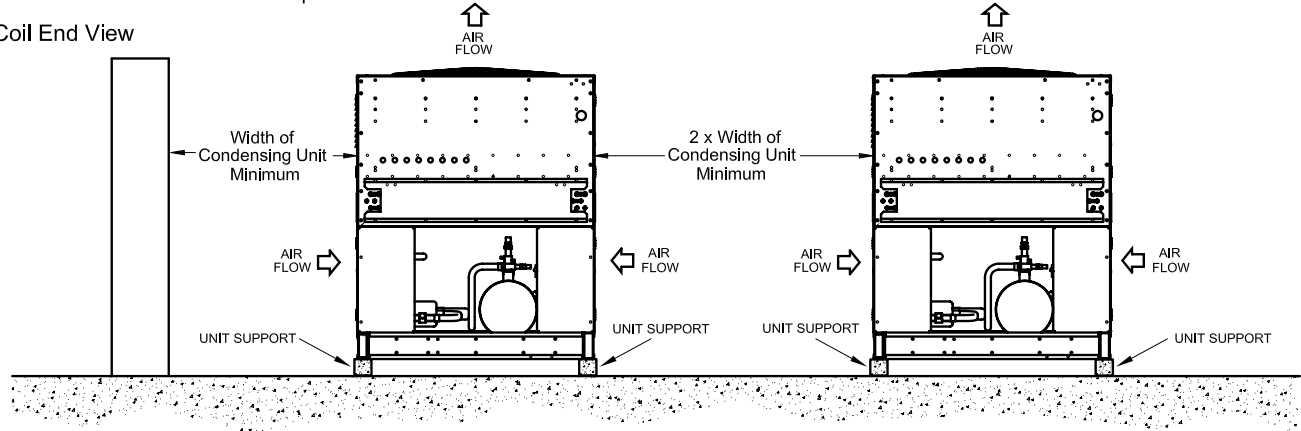

Side View

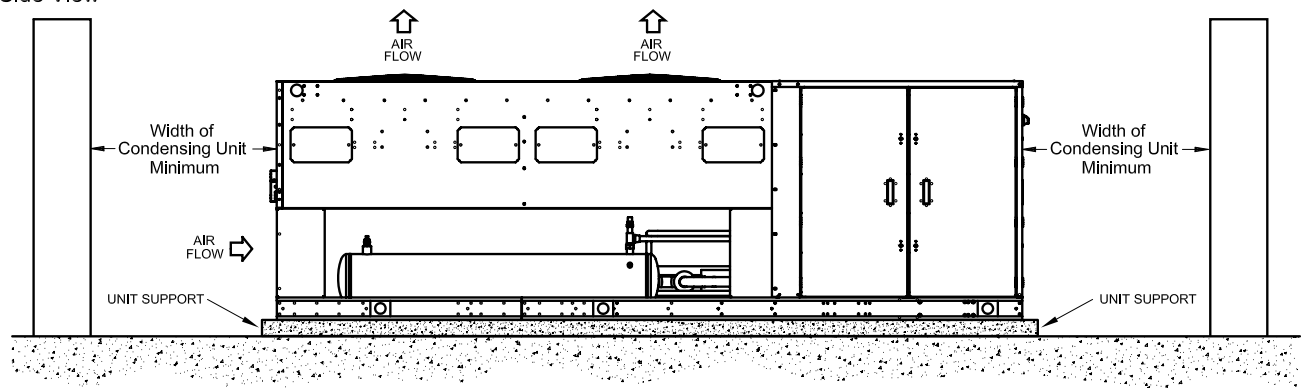

UNITS IN PITS

The top of the unit must be level with or above the top of the pit. In addition, a minimum of 2 condenser widths is required between the unit and the pit walls.

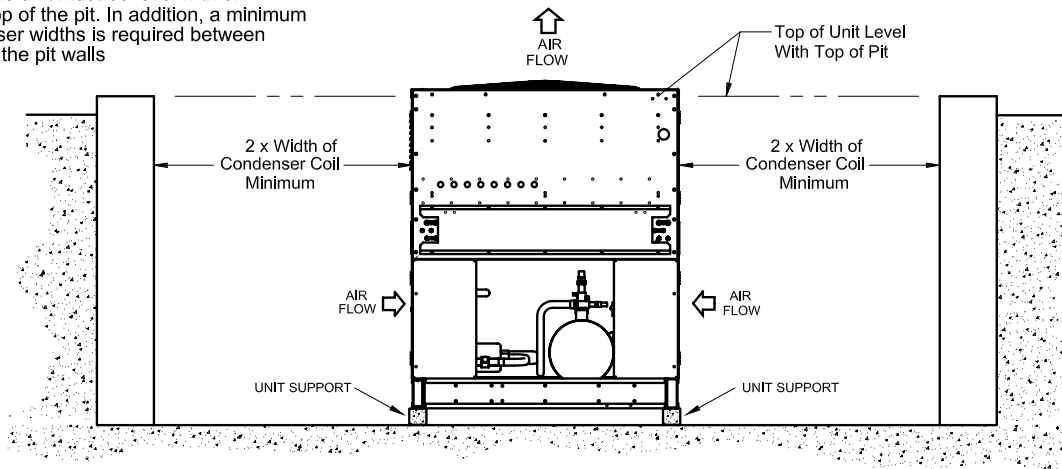

UNIT SUPPORT NOTE: SUPPORTS MUST BE PLACED UNDER THE LONGITUDINAL LENGTH ON BOTH SIDES OF THE UNIT.

LOCATION: Vertical Air Flow Condensing Units (cont'd)

COMPRESSOR END to COMPRESSOR END
or COMPRESSOR END to COIL END

A minimum of 1 condensing unit width must be allowed
between units placed compressor end to compressor end or
compressor end to coil end

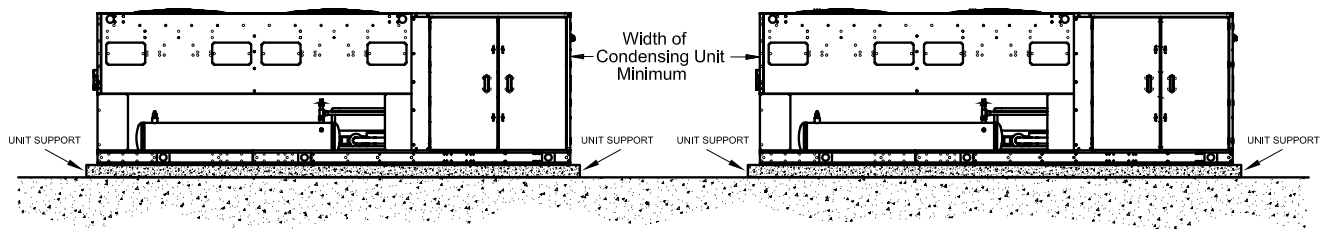
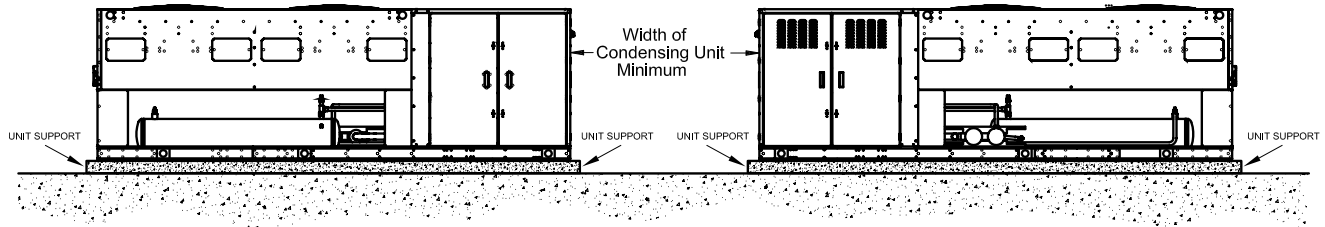

COIL END to COIL END

A minimum of 2 condensing unit widths must be allowed
between units placed coil end to coil end.

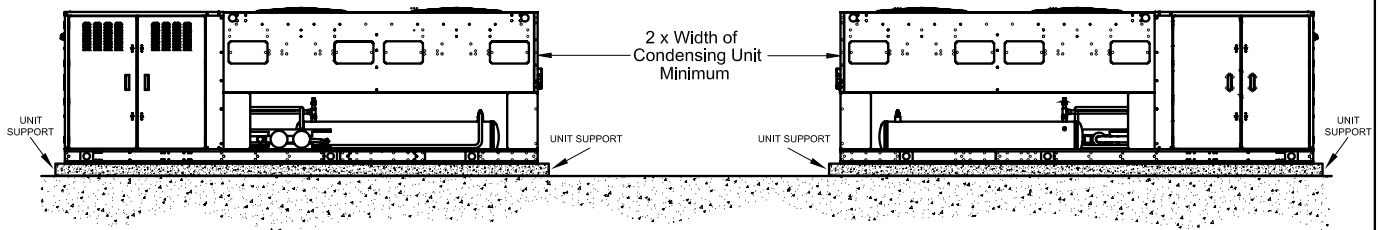

UNIT SUPPORT NOTE: SUPPORTS MUST BE PLACED UNDER THE LONGITUDINAL LENGTH ON BOTH SIDES OF THE UNIT.

LIFTING INSTRUCTIONS

Condensing units can be large, heavy, mechanical equipment and must be handled as such. A fully qualified and properly equipped crew with necessary rigging should be engaged to set the condensing unit into position.

Horizontal Air Flow Models

Lifting holes have been provided on larger models for attaching lifting slings.

Spreader bars must be used when lifting so that lifting forces are applied vertically.

Optional air discharge covers and hail guards must be in closed position for lifting to avoid damage by lifting cables or slings.

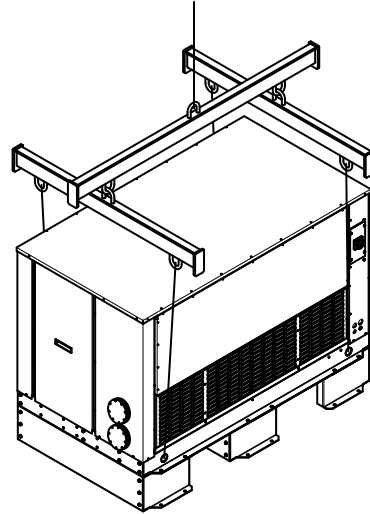

Vertical Air Flow Models

Heavy gauge welded lifting lugs have been provided in strategic locations along the base frames to allow units to be lifted as level as possible. Use the lugs at the compressor end always, and find the lugs toward the opposite end that allow for the most level lift.

Spreader bars must be used when lifting so that lifting forces are applied vertically and damage to cabinet and coil casing does not occur.

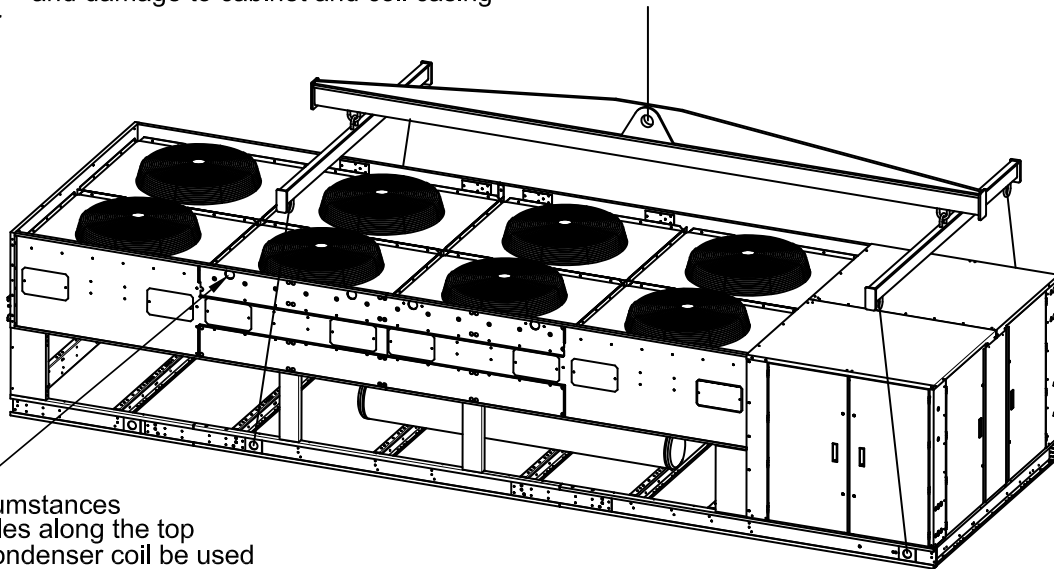

Important:

under no circumstances should the holes along the top edge of the condenser coil be used to lift an entire unit (Damage to the unit will result)

In the rare circumstance that the condenser coil needs to be separated from the unit, the backer plates can be removed from these holes and the coil section can be lifted off. All heavy gauge side gussets must remain in place for any coil servicing removal.

ELECTRICAL INFORMATION

NOTE: All installers should follow the wiring diagram attached to the equipment electrical compartment cover.

WARNING

All wiring and connections to the unit must be made in accordance with national as well as local electrical codes and by-laws.

Electrical wiring should be sized in accordance with the minimum circuit ampacity (MCA) shown on the unit nameplate and applicable electrical codes. The unit power connections are approved for copper wire only.

Connect the field power supply through a properly sized branch circuit protection disconnect switch. The entering service fuse must not exceed the maximum overcurrent protection (MOP) value on the unit data plate.

Field connected control circuit wires are terminated directly at the control circuit terminal block in accordance with the appropriate wiring diagram.

Voltage at the unit terminals must not vary more than the allowable variation during start-up and while under full load. If the voltage is normal at the supply with the compressor not running and drops considerably when the switch is closed and the motor is trying to start, there is a high resistance due to undersized wires or faulty connections. Voltage drop between inoperative and full load must not exceed 3% of line voltage. In addition, the phase imbalance at the motor terminals should be within 2% on three phase units.

60 Hz Supply

Power	Allowable Variation
115-1-60	103-127 V
208/230-1-60	197-254 V
208/230-3-60	187-254 V
460-3-60	414-506 V
575-3-60	518-632 V

50 Hz Supply

Power	Allowable Variation
100-1-50	90-110 V
200/220-1-50	190-242 V
200/220-3-50	180-242 V
380/400-3-50	342-440 V

All systems should use a liquid line solenoid valve (installed at the evaporator) and should be energized by the room or fixture thermostat. For systems with a defrost time clock, the liquid line solenoid and thermostat should be energized by the time clock. Initially set the defrost time clock (model 8145) as follows:

Air defrost evaporators; 3 per day (every 8 hours) with the time termination at 45 minutes.

Electric defrost evaporators; 4 per day (every 6 hours) with time termination set (Fail Safe) at 30 minutes. Check that the wiring from the defrost termination thermostat is wired to terminal "X" on the clock and terminates the defrost cycle when the evaporator coil reaches approximately 55 °F. The fan delay thermostat wiring should also be checked for proper operation. This ensures that all water droplets have been refrozen to the coil before the evaporator fan starts back up.

Note: The above settings are guidelines only and must be re-adjusted to suit local field conditions and actual evaporator equipment specifications.

Refer to the evaporator installation manual for further information.

Refer to the following wiring diagrams for typical air defrost and electric defrost wiring arrangements.

WARNING

Any deviation or change to the electrical components or wiring as supplied on the original equipment, or noncompliance with the voltage and phase balance requirements without written authorization will void the warranty.

ELECTRICAL INFORMATION (cont'd)

Wiring Diagram Cross Reference

Condensing Unit Voltage	Evaporator Voltage and Type	Condensing Unit Type	Diagram Number	Page	Diagram Number	Page
COPELAND SCROLL						
208-230/1/60	230 Air Defrost Low Profile	Small Scroll	S2A1D	A2	KA101	A13
208-230/3/60	230 Electric Defrost Low Profile	Small Scroll	T3A1A	A3	LPE101	A14
208-230/3/60	2x 230 Electric Defrost Low Profile	Small Scroll+ Coresense	T3A1D	A5	LPE201	A15
208-230/3/60	2x 230 Electric Defrost Med Profile	Large Scroll+ Coresense	T3C6A	A6	JE101A	A16
460/3/60	460 Electric Defrost Med Profile	Small Scroll+ Coresense	T4A6A	A9	JE101A	A16
460/3/60	2x 460 Electric Defrost Med Profile	Large Scroll+ Coresense	T4C6A	A10	JE201A	A17
COPELAND HERMETIC						
208-230/1/60	230 Air Defrost Low Profile		S2A1A	A1	KA101	A13
208-230/3/60	230 Electric Defrost Low Profile		T3A1A	A3	LPE101	A14
460/3/60 & 575/3/60	2x 230 Electric Defrost Low Profile		T4A1A	A8	JE101A	A16
SEMI-HERMETIC						
208-230/1/60	230 Air Defrost Low Profile	Copelametic	S2A1A	A1	KA101	A13
208-230/3/60	230 Electric Defrost Low Profile	Bitzer	T3B1A	A4	LPE101	A14
208-230/3/60	2x 230 Electric Defrost Low Profile	Discus	T3L1A	A7	LPE201	A15
460/3/60 & 575/3/60	460 Electric Defrost Med Profile	Discus	T4L1A	A12	JE101A	A16
460/3/60 & 575/3/60	2x 460 Electric Defrost Med Profile	Discus Demand Cooling	T4A4A	A11	JE201A	A17

for wiring diagrams, see:

***Appendix A:
Wiring Diagrams***

REFRIGERANT PIPING

WARNING

All local codes must be observed in the installation of refrigerant piping.

IMPORTANT PIPING NOTE

Appropriate line sizing practices must be used throughout the installation of the refrigeration system. Special consideration must be taken when the condensing unit is installed above the evaporator. **REFRIGERATION GRADE COPPER TUBING MUST BE USED FOR PIPING SYSTEMS.**

Piping practice and line sizing charts as recommended by A.S.H.R.A.E. or other reputable refrigeration standards must be followed to ensure minimum pressure drop and correct oil return. An inert gas such as dry nitrogen should be passed through the piping during welding or brazing operations. This reduces or eliminates oxidation of the copper and formation of scale inside the piping. For specific piping requirements refer to your local distributor or sales representative.

Correct line sizing is most critical because of the several factors involved:

- (a) Minimum pressure drop to ensure efficient compressor performance.
- (b) Sufficient gas velocity to maintain proper oil return to the compressor under all load conditions.
- (c) Elimination of conditions on multiple evaporators whereby oil may log in an idle evaporator.

Suction lines should be sized on the basis of a maximum total pressure drop equivalent to a 2°F (1.1°C) change in saturated temperature.

Horizontal liquid lines should be sized on a basis of a maximum pressure drop equivalent to a 2°F (1.1°C) drop in the sub-cooling temperature. If the lines must travel up vertically then adequate sub-cooling must be provided to overcome the vertical liquid head pressures. A head of two feet of liquid refrigerant is approximately equivalent to 1 psig (6.9 kPa). Liquid line velocities should not exceed 300 fpm (1.52 m/s). This will prevent possible liquid hammering when the solenoid valve closes.

Pressure Loss of Liquid Refrigerant in Liquid Line Risers (Expressed in Pressure Drop PSIG and Subcooling Loss °F)

Refrigerant	Liquid Line Rise in Feet									
	10'		15'		20'		25'		30'	
	PSIG	°F	PSIG	°F	PSIG	°F	PSIG	°F	PSIG	°F
R134a	4.9	2.0	7.4	2.9	9.8	4.1	12.3	5.2	14.7	6.3
R22	4.8	1.6	7.3	2.3	9.7	3.1	12.1	3.8	14.5	4.7
R404A R507	4.1	1.1	6.1	1.6	8.2	2.1	10.2	2.7	12.2	3.3
R407A R407C R448A	4.3	1.4	6.5	2.1	8.7	2.8	10.8	3.5	12.8	4.1

REFRIGERANT PIPING (cont'd)

At the temperatures encountered in the condenser, receiver and liquid line a certain amount of oil is always being circulated with the refrigerant through the system by the compressor. However, at the evaporator temperature, and with the refrigerant in a vapor state, the oil and refrigerant separate. This oil can only be returned to the compressor by gravity or by entrainment in the suction gas. Roof installations leave no alternative but by entrainment for oil return, so suction gas velocity and correct line sizing to maintain this velocity are imperative. Care must be taken

not to oversize the suction line in the desire for maximum performance.

Gas velocity in vertical suction lines must not be less than 1,000 fpm (5 m/s) and preferably 1,250 to 1,500 fpm (6 to 8 m/s).

Important: A suction trap must be installed at the base of all suction risers of four (4) feet or more in order to trap oil and allow entrainment in the suction gas.

TYPICAL SUCTION P-TRAP

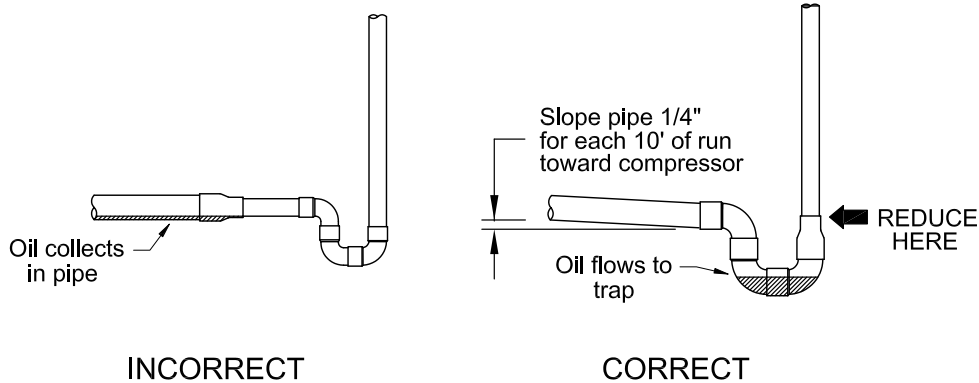

IMPORTANT PIPING NOTE

If steps of capacity control are supplied on a compressor, provisions must be made for oil return by sizing suction risers to maintain adequate gas velocities at reduced refrigerant flow.

TYPICAL DOUBLE RISER CONSTRUCTION

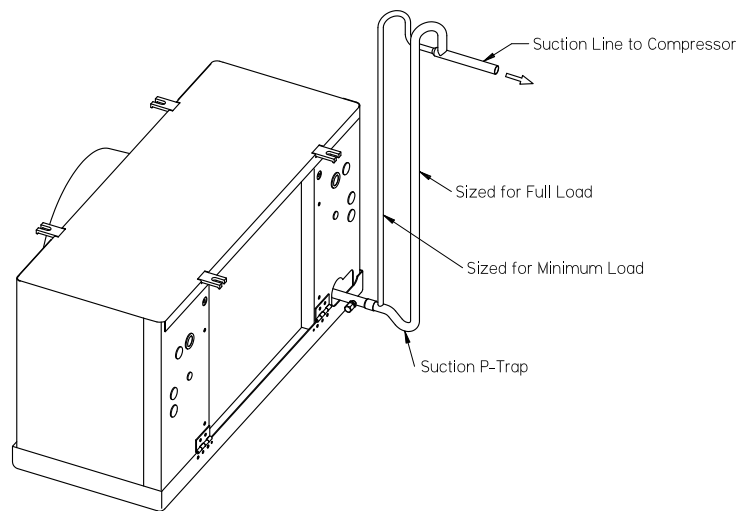

During the lower capacity running mode (compressor capacity control energized) oil will collect in the elbow or at U-bend below pipe "B". This will divert the gas and oil to flow up the smaller pipe "A" at a higher velocity.

IMPORTANT: When welding service valves or any components that may be damaged by heat, manufacturer's installation instructions must be adhered to. Wrapping components with a wet cloth will help to prevent damage from heat.

IMPORTANT: All suction lines outside of the refrigerated space must be insulated.

PIPING

REMOTE CONDENSER - TYPICAL SYSTEM PIPING

Figure 3 - Single circuit

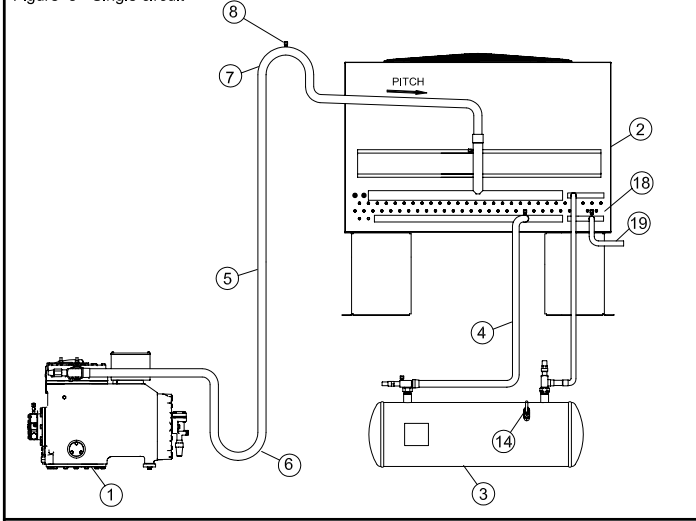

Figure 4a - Single circuit with double discharge riser (May be required with capacity control)

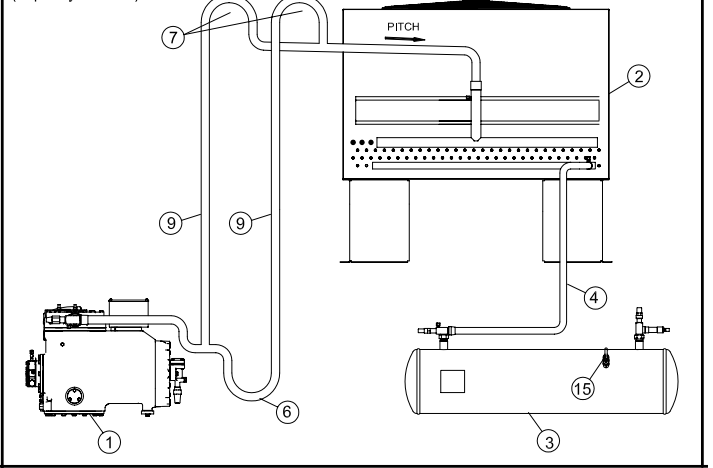

Figure 4b - Single circuit with oil separator (May be required with capacity control)

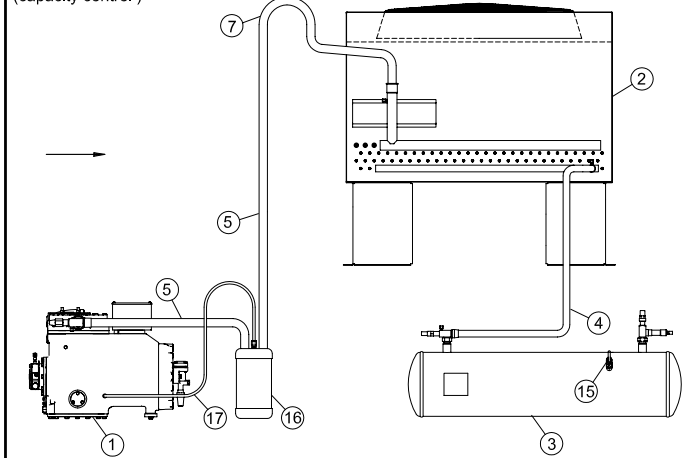

Figure 5 - Single circuit With regulator valve head pressure control

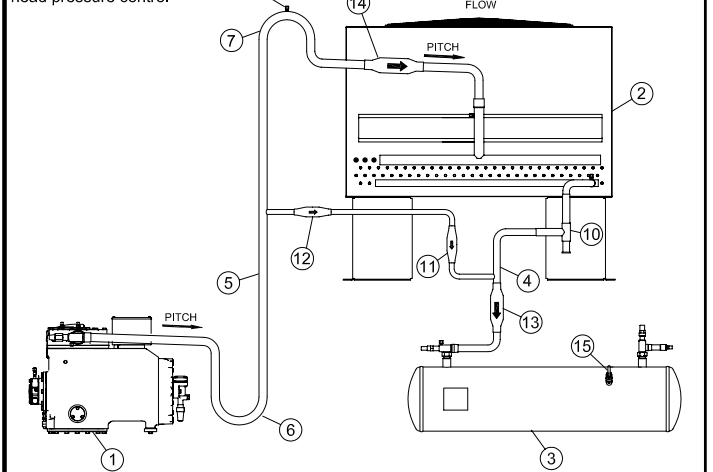
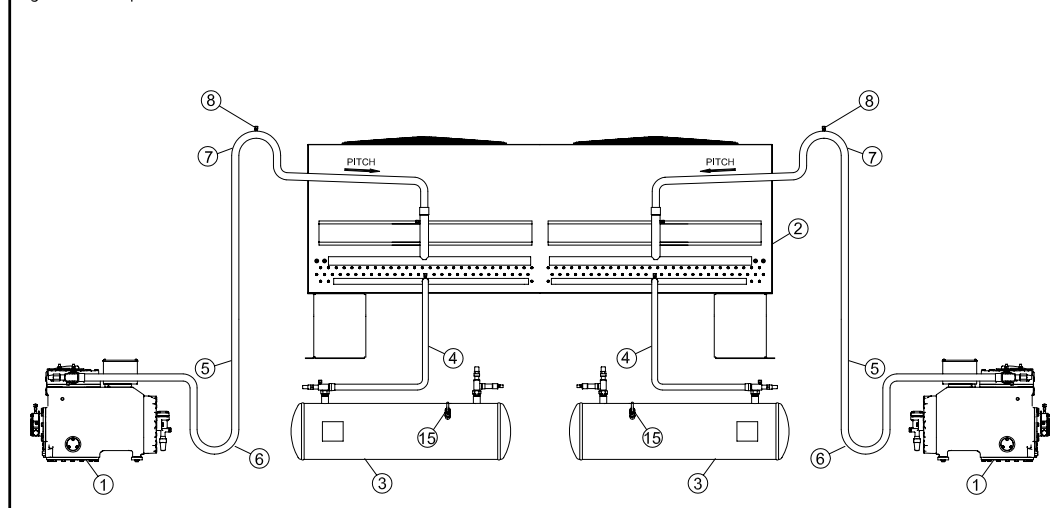

Figure 6 - Multiple circuit



LEGEND

- 1). Compressor
- 2). Air Cooled Condenser
- 3). Receiver
- 4). Condensate Line
- 5). Discharge Line
- 6). Trap - Min 18" (457mm)
- 7). Reverse Trap - Min 6" (152mm)
- 8). Access Schrader Valve
- 9). Double Discharge Riser
- 10). Head Pressure Regulator (Open on rise of Inlet)
- 11). Receiver Pressure Regulator (Open on rise of Differential)
- 12). Check Valve "A"
- 13). Check Valve "B"
- 14). Check Valve "C"
- 15). Receiver Relief Valve
- 16). Oil Separator
- 17). Oil Return Line
- 18). Subcooler Circuit
- 19). Liquid Line

LINE INSULATION

After the final system leak test is complete, it is important that all refrigerant lines exposed to high ambient conditions must be insulated to reduce the heat pick-up and prevent the formation of flash gas in the liquid lines. Suction lines should be insulated with 3/4 inch wall insulation, Armstrong "Armaflex" or equal. To prevent rupture due to condensate re-freezing, all **suction vibration** eliminators

on low temperature systems **MUST BE COMPLETELY INSULATED**. Liquid lines exposed to high ambient temperatures should be insulated with 1/2 inch wall insulation or better. Any insulation that is to be located in an outdoor environment should be protected from UV exposure to prevent deterioration of the insulating value.

REFRIGERANT CHARGING

Condensing units must be charged only with the refrigerant for which they were designed. The type of refrigerant to be used is specified on the name plate of the unit. Installing a liquid line drier between the service gauge and the liquid service port when charging a unit will ensure the refrigerant supplied to the system is clean and dry. This is especially important when charging a low

temperature system. Blend type refrigerants (400 series, i.e. R404A) **must not be vapor charged** unless the cylinder is completely emptied into the system.

Weigh the refrigerant drum before and after charging in order to keep an accurate record of the weight of refrigerant put into the system.

IMPORTANT REFRIGERANT CHARGING NOTE

Overcharging a system can result in poor system performance, personal injury and / or compressor damage. **DO NOT** charge strictly by the holding capacity of the receiver. **DO NOT** assume that bubbles in a sight glass, when located at the condensing unit, indicates the system is undercharged.

Note: To estimate the total system requirement, refer to the manufacturer's evaporator and condensing unit specifications on typical operating charges and include the amount for the liquid lines (see tables below). Allow an extra 10% to 15% safety factor. Ensure the receiver can handle the required charge during the pump down mode. (Refer to the condensing unit brochure pump down specifications).

Break the vacuum by charging liquid refrigerant into the receiver side only (charge through the receiver outlet valve gauge port with the valve in the open position). Close the valve and then continue to charge through the gauge port feeding the liquid line and evaporator. Start the compressor and continue to charge.

Refrigerant may be added at the compressor through the compressor suction service valve in gas form only. When liquid charging is used, a liquid charging valve must be installed. While charging the system, special attention should be paid to the oil level in the compressor.

If charging to the "bubble" method (observing liquid line sight glass), always use a sight glass located directly before the TXV (thermostatic expansion valve) for the final indicator.

(see next page for details on Valve Systems)

REFRIGERANT CHARGING - VALVE SYSTEMS

DUAL OR ADJUSTABLE LAC VALVE SYSTEMS:

The system employs an adjustable LAC or ORI/ORD valves to regulate system high pressure during low ambient conditions.

The design compressor discharge pressure setting for the valve is 150 psig for medium temperature systems and low temperature systems with hermetic compressors; and 120 psig for other low temperature systems.

All systems are factory set at the above settings; however, the actual compressor discharge pressure at low ambient conditions may differ from the factory settings. If so, the setting needs to be adjusted. **Caution: setting the valve higher than the design setting is not permitted.**

Exception: If the system is not used for a walk-in, or a walk-in larger than 3000 ft², or for medical, scientific or research purpose, the above setting requirement does not apply.

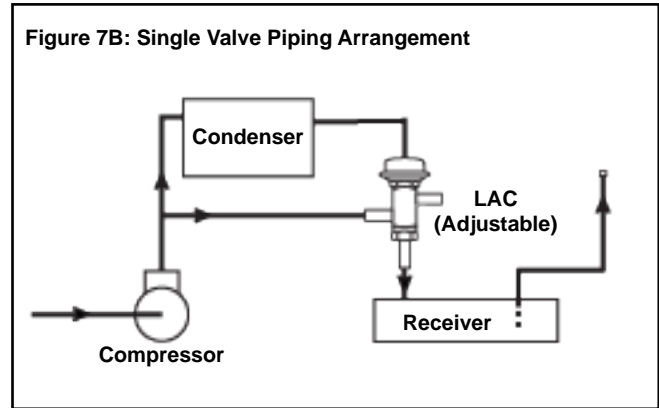
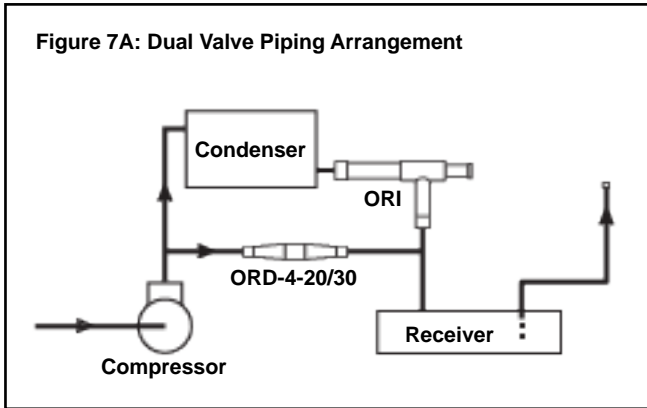

Adjustment:

When an adjustment is needed, a pressure gauge should be connected to the compressor discharge port. Turning the valve stem "clockwise" will increase the pressure setting, while turning the valve stem "counterclockwise" will decrease the pressure setting.

Checking and adjusting the valve setting may only be done properly when the ambient temperature reaches 35°F or below

Refer to Sporlan's installation instructions (bulletins 90-30-1 and 90-31) for further details.

WARNING

Fans closest to the headers should not be cycled on standard temperature or pressure controls. Dramatic temperature and pressure changes at the headers as a result of fan action can result in possible tube failure.

Fan cycling controls should be adjusted to maintain a minimum of 5 minutes on and 5 minutes off. Short cycling of fans may result in premature failure of motor and/or fan blade.

Compressors operating below +10°F SST must have air flowing over the compressor at all times when the compressor is running.

REFRIGERANT CHARGING (cont'd)

TEH-LINE HERMETIC AIR-COOLED CONDENSING UNIT (WITH HORIZONTAL AIRFLOW CONDENSERS)

Refrigerant Operating Charges (Lbs) (Less Evaporator And Liquid Lines)

UNIT MODEL	R404A	R448A	UNIT MODEL	(M6/M8) R404A	(M6/M8) R448A	(H7) R407C	(H7) R22
TEHA006L6 TEHA008L6 TEHA010L6 TEHA015L6	2.0	2.09	TEHA006M8 TEHA008M8 TEHA009M8	2.0	2.09	2.2	2.3
TEHA020L6	2.8	2.92	TEHA010M8 TEHA011M8	2.8	2.92	3.0	3.2
-	-	-	TEHA013M8 TEHA015M6 TEHA020M6 TEHA015H7 TEHA020H7	4.2	4.3	4.5	4.7
TEHA025L6 TEHA030L6	5.8	6.1	TEHA025M6 TEHA029M6 TEHA025H7 TEHA029H7	6.0	6.3	6.5	6.8
-	-	-	TEHA030M6 TEHA035M6 TEHA030H7 TEHA035H7 TEHA040H7	8.6	8.9	9.3	9.7
-	-	-	TEHA050H7	-	-	12	12

TEZ-LINE SCROLL AIR-COOLED CONDENSING UNIT (WITH HORIZONTAL AIRFLOW CONDENSERS)

Refrigerant Operating Charges (Lbs) (Less Evaporator And Liquid Lines)

UNIT MODEL	R404A	R407A	R448A	UNIT MODEL	R404A	R407A	R448A	R407C	R22
TEZA008L8 TEZA010L8	2.0	2.2	2.1	TEZA007H8	2.0	2.2	2.1	2.2	2.3
TEZA015L8	2.8	3.1	2.9	TEZA008H8 TEZA009H8	2.8	3.1	2.9	3.0	3.2
-	-	-	-	TEZA010H8 TEZA011H8 TEZA015H8 TEZA020H8	4.2	4.5	4.3	4.5	4.7
TEZA020L8	3.9	4.3	4.1	-	-	-	-	-	-
TEZA025L8 TEZA030L8 TEZA035L8	6.0	6.6	6.3	TEZA025H8	6.0	6.6	6.3	6.5	6.8
TEZA045L8	8.6	9.4	8.9	TEZA030H8 TEZA035H8 TEZA040H8	8.6	9.4	8.9	9.3	9.7
TEZA055L8 TEZA060L8	11	12	12	TEZA045H8 TEZA050H8	11	12	12	12	13
TEZA075L8 TEZA085L8 TEZA100L8	18	20	19	TEZA060H8 TEZA061H8 TEZA070H8	18	20	19	19	20
TEZA130L8 TEZA150L8	23	25	24	TEZA076H8 TEZA085H8	23	25	24	25	25
-	-	-	-	TEZA110H8 TEZA150H8	39	42	40	41	43

REFRIGERANT CHARGING (cont'd)

TES-LINE SEMI-HERMETIC AIR-COOLED CONDENSING UNIT (WITH HORIZONTAL AIRFLOW CONDENSERS)

Refrigerant Operating Charges (Lbs) (Less Evaporator And Liquid Lines) - COPELAND

UNIT MODEL	(L6) R404A	(L8) R407A	(L6/L8) R448A	UNIT MODEL	R404A	R407A	R448A	R407C	R22
-	-	-	-	TESA010M8	2.8	3.1	2.9	3.0	3.2
TESA005L8 TESA008L8 TESA010L8	2.6	-	3.0	-	-	-	-	-	-
TESA015L8 TESA020L8 TESA021L8	4.5	-	5.1	TESA020M8	4.5	-	4.7	-	-
-	-	-	-	TESA021M8	5.8	-	6.1	-	-
TESA030L8 TESA032L8	8.6	-	8.8	TESA030M8	8.6	-	8.8	-	-
TESA035L6/L8	8.6	9.1	8.8	-	-	-	-	-	-
TESA040L6/L8	9.6	10.7	10.2	-	-	-	-	-	-
TESA060L6/L8 TESA061L6/L8 TESA075L6/L8	18	20	19	TESA050H8 TESA051H8 TESA075H8	18	20	19	19	20
TESA090L6/L8 TESA100L6/L8	23	25	24	TESA077H8 TESA080H8 TESA100H8	23	25	24	25	25
TESA120L6/L8 TESA130L6/L8 TESA150L6/L8 TESA220L6/L8	39	42	40	TESA120H8 TESA150H8 TESA200H8	39	42	40	41	43

Refrigerant Operating Charges (Lbs) (Less Evaporator And Liquid Lines) - BITZER

UNIT MODEL	(L6) R404A	(L8) R407A	(L6/L8) R448A	UNIT MODEL	R404A	R407A	R448A	R407C	R22
TESB010L6/L8	3.0	3.2	3.1	TESB010H8	3.5	3.8	3.6	3.8	3.9
TESB015L6/L8 TESB020L6/L8	4.4	4.9	4.6	TESB015H8 TESB020H8	4.4	4.9	4.6	4.8	5.0
TESB025L6/L8	6.0	6.6	6.3	TESB025H8	6.0	6.6	6.3	6.5	6.8
TESB030L6/L8 TESB031L6/L8	8.6	9.4	8.9	TESB029H8 TESB030H8	8.6	9.4	8.9	9.3	9.7
TESB039L6/L8	11	12	12	TESB035H8 TESB040H8	11	12	12	12	13
TESB050L6/L8 TESB060L6/L8	18	20	19	TESB050H8 TESB060H8	18	20	19	19	20
TESB080L6/L8 TESB100L6/L8 TESB120L6/L8	23	25	24	TESB076H8 TESB090H8 TESB100H8	23	25	24	25	25
-	-	-	-	TESB121H8 TESB150H8 TESB200H8	39	42	40	41	43

REFRIGERANT CHARGING (cont'd)

TQH-LINE QUIET HERMETIC AIR-COOLED CONDENSING UNIT (WITH HORIZONTAL AIRFLOW CONDENSERS)

Refrigerant Operating Charges (Lbs) (Less Evaporator And Liquid Lines)

UNIT MODEL	R404A	R407A	R448A	UNIT MODEL	R404A	R407A	R448A	R407C
TQZA008L8 TQZA010L8 TQZA015L8 TQZA020L8	3.5	4.2	3.7	TQZA007H8 TQZA008H8 TQZA009H8 TQZA010H8 TQZA011H8	3.5	4.2	3.7	4.4
TQZA025L8 TQZA030L8	3.8	4.2	4.0	TQZA015H8 TQZA020H8	3.8	4.2	4.0	4.1
TQZA035L8	4.6	5.0	4.8	TQZA025H8	5.8	5.0	4.8	5.0
-	-	-	-	TQZA030H8	5.4	5.9	5.6	5.87
TQZA045L8	5.8	6.4	6.1	TQZA035H8	5.8	6.4	6.1	6.4
TQZA055L8 TQZA060L8	7.4	8.1	7.7	TQZA040H8 TQZA050H8	7.4	8.1	7.7	8.0
-	-	-	-	TQZA060H8	9.6	11	10	10

TQZ-LINE QUIET SCROLL AIR-COOLED CONDENSING UNIT (WITH HORIZONTAL AIRFLOW CONDENSERS)

Refrigerant Operating Charges (Lbs) (Less Evaporator And Liquid Lines)

UNIT MODEL	R404A	R448A	UNIT MODEL	(E6/M8) R404A	(E6/M8) R448A	(H7) R407C	(H7) R22
TQHA010L6 TQHA020L6	2.7	2.8	TQHA006M8 TQHA008M8 TQHA009M8 TQHA010M8	2.7	2.8	-	-
-	-	-	TQHA011M8 TQHA013M8 TQHA015H7	3.5	3.7	3.8	4.0
TQHA025L6 TQHA030L6	3.9	4.1	TQHA015E6 TQHA020E6 TQHA025E6 TQHA030E6 TQHA020H7	3.9	4.1	4.2	4.4
-	-	-	TQHA035E6 TQHA035H7	4.5	4.7	5.0	5.1
-	-	-	TQHA025H7 TQHA030H7	-	-	6.0	6.2
-	-	-	TQHA040H7 TQHA050H7	-	-	7.6	7.9

REFRIGERANT CHARGING (cont'd)

MEDIUM AIR-COOLED CONDENSING UNIT (WITH VERTICAL AIRFLOW CONDENSERS)

Refrigerant Operating Charges (Lbs) (Less Evaporator And Liquid Lines)

Single Compressor UNIT MODEL		RECEIVER	TOTAL UNIT CHARGE R404A † (lb)		Single Compressor UNIT MODEL		RECEIVER	TOTAL UNIT CHARGE R404A † (lb)	
Copeland	Bitzer	90% Full (lb)	Summer (+10% receiver)	Winter (+10% receiver)	Copeland	Bitzer	90% Full (lb)	Summer (+10% receiver)	Winter (+10% receiver)
TMS075L 6/8-A	TMS080L 6/8-B	70	19.3	37.3	TMD150L 6/8-A	TMD160L 6/8-B	70(2)	38.6	74.5
TMS090L 6/8-A	TMS100L 6/8-B	70	19.3	37.3	TMD180L 6/8-A	TMD200L 6/8-B	70(2)	38.6	74.5
TMS100L 6/8-A	TMS120L 6/8-B	82	20.5	36.8	TMD200L 6/8-A	TMD240L 6/8-B	82(2)	41.0	73.6
TMS120L 6/8-A		103	28.2	54.0	TMD240L 6/8-A		103(2)	56.4	107.9
TMS130L 6/8-A	TMS130L 6/8-B	103	28.2	54.0	TMD260L 6/8-A	TMD260L 6/8-B	103(2)	56.4	107.9
TMS150L 6/8-A	TMS150L 6/8-B	124	30.3	56.1	TMD300L 6/8-A	TMD300L 6/8-B	124(2)	60.6	112.1
TMS220L 6/8-A	TMS200L 6/8-B	124	35.3	69.4	TMD440L 6/8-A	TMD400L 6/8-B	124(2)	70.6	138.7
TMS075M8-A	TMS060M8-B	70	19.3	37.3	TMD150M8-A	TMD120M8-B	70(2)	38.6	74.5
TMS076M8-A	TMS075M8-B	70	19.3	37.3	TMD151M8-A	TMD150M8-B	70(2)	38.6	74.5
TMS080M8-A	TMS090M8-B	82	20.5	36.8	TMD160M8-A	TMD180M8-B	82(2)	41.0	73.6
TMS100M8-A	TMS100M8-B	103	28.2	54.0	TMD200M8-A	TMD200M8-B	103(2)	56.4	107.9
TMS120M8-A	TMS120M8-B	124	33.0	66.5	TMD240M8-A	TMD240M8-B	124(2)	65.9	132.9
TMS150M8-A	TMS150M8-B	124	33.0	66.5	TMD300M8-A	TMD300M8-B	124(2)	65.9	132.9
	TMS200M8-B	124	36.7	71.0		TMD400M8-B	124(2)	73.3	142.0
TMS075H8-A	TMS060H8-B	70	18.4	35.6	TMS075H8-A	TMD120H8-B	70(2)	36.8	71.2
TMS076H8-A	TMS075H8-B	70	18.4	35.6	TMS076H8-A	TMD150H8-B	70(2)	36.8	71.2
TMS080H8-A	TMS090H8-B	82	19.9	35.7	TMS080H8-A	TMD180H8-B	82(2)	39.8	71.4
TMS100H8-A	TMS100H8-B	103	25.1	49.4	TMS100H8-A	TMD200H8-B	103(2)	50.2	98.8
TMS120H8-A	TMS120H8-B	124	29.9	61.7	TMS120H8-A	TMD240H8-B	124(2)	59.8	123.3
TMS150H8-A	TMS150H8-B	124	29.9	61.7	TMS150H8-A	TMD300H8-B	124(2)	59.8	123.3
	TMS200H8-B	124	33.6	66.3		TMD400H8-B	124(2)	67.2	132.6
TMS060L8-Z		50	16.4	34.1	TMD120L8-Z		50(2)	32.7	68.2
TMS075L8-Z		50	16.4	34.1	TMD150L8-Z		50(2)	32.7	68.2
TMS085L8-Z		50	17.0	34.9	TMD170L8-Z		50(2)	33.9	69.8
TMS100L8-Z		50	17.0	34.9	TMD200L8-Z		50(2)	33.9	69.8
TMS130L8-Z		60	21.4	46.4	TMD260L8-Z		60(2)	42.8	92.7
TMS150L8-Z		70	22.4	47.4	TMD300L8-Z		70(2)	44.8	94.7
TMS170L8-Z		82	27.5	60.7	TMD340L8-Z		82(2)	55.1	121.4
TMS050M8-Z		50	14.9	28.6	TMD100M8-Z		50(2)	29.9	57.3
TMS060M8-Z		50	15.6	29.4	TMD120M8-Z		50(2)	31.1	58.8
TMS061M8-Z		60	17.5	31.6	TMD121M8-Z		60(2)	35.0	63.1
TMS070M8-Z		60	18.3	34.6	TMD140M8-Z		60(2)	36.6	69.2
TMS076M8-Z		70	21.8	38.9	TMD151M8-Z		70(2)	43.6	77.7
TMS085M8-Z		82	23.0	40.1	TMD170M8-Z		82(2)	46.0	80.1
TMS110M8-Z		103	30.9	64.4	TMD220M8-Z		103(2)	61.7	128.7
TMS150M8-Z		103	30.9	64.4	TMD300M8-Z		103(2)	61.7	128.7
TMS050H8-Z		50	14.0	27.1	TMD100H8-Z		50(2)	28.0	54.1
TMS060H8-Z		50	14.0	27.1	TMD120H8-Z		50(2)	28.0	54.1
TMS061H8-Z		60	16.0	29.3	TMD121H8-Z		60(2)	32.0	58.5
TMS070H8-Z		60	17.7	33.5	TMD140H8-Z		60(2)	35.4	67.0
TMS076H8-Z		70	18.7	34.5	TMD151H8-Z		70(2)	37.4	69.0
TMS085H8-Z		82	19.9	35.7	TMD170H8-Z		82(2)	39.8	71.4
TMS110H8-Z		103	27.8	59.6	TMD220H8-Z		103(2)	55.6	119.1
TMS150H8-Z		103	31.5	64.2	TMD300H8-Z		103(2)	63.0	128.4

† NOTE ON ALTERNATE REFRIGERANTS: PUBLISHED RECEIVER CAPACITY IS BASED ON R404A ON MODELS USING "8" AS REFRIGERANT CODE. FOR ALTERNATE REFRIGERANTS, MULTIPLY R404A VALUE BY THE APPROPRIATE VALUE BELOW:

R407A	R407C	R448A	R507	R22
1.10	1.10	1.05	1.00	1.15

- For R449A, use R448A data.

REFRIGERANT CHARGING (cont'd)

LARGE AIR-COOLED CONDENSING UNIT (WITH VERTICAL AIRFLOW CONDENSERS)

Refrigerant Operating Charges (Lbs) (Less Evaporator And Liquid Lines)

Single Compressor UNIT MODEL		RECEIVER	TOTAL UNIT CHARGE R404A † (lb)		Double Compressor UNIT MODEL		RECEIVER	TOTAL UNIT CHARGE R404A † (lb)	
Copeland	Bitzer	90% Full (lb)	Summer (+10% receiver)	Winter (+10% receiver)	Copeland	Bitzer	90% Full (lb)	Summer (+10% receiver)	Winter (+10% receiver)
TVS010L 6/8-A	TVS012L 6/8-B	70	19.0	34.6	TVD020L 6/8-A	TVD024L 6/8-B	70(2)	38.1	69.3
TVS015L 6/8-A	TVS015L 6/8-B	82	23.8	44.8	TVD030L 6/8-A	TVD030L 6/8-B	82(2)	47.7	89.5
TVS022L 6/8-A	TVS020L 6/8-B	103	27.9	47.9	TVD044L 6/8-A	TVD040L 6/8-B	103(2)	55.7	95.8
TVS027L 6/8-A	TVS025L 6/8-B	124	37.7	68.6	TVD054L 6/8-A	TVD050L 6/8-B	124(2)	75.4	137.2
TVS030L 6/8-A	TVS030L 6/8-B	124	37.7	68.6	TVD060L 6/8-A	TVD060L 6/8-B	124(2)	75.4	137.2
TVS040L 6/8-A	TVS040L 6/8-B	157	46.1	85.1	TVD080L 6/8-A	TVD080L 6/8-B	157(2)	92.2	170.2
TVS015M8-A	TVS015M8-B	103	25.5	45.0	TVD030M8-A	TVD030M8-B	103(2)	51.0	89.9
TVS020M8-A	TVS020M8-B	103	32.9	63.0	TVD040M8-A	TVD040M8-B	103(2)	65.8	125.9
TVS022M8-A		103	35.6	66.5	TVD044M8-A		103(2)	71.2	133.0
TVS025M8-A	TVS025M8-B	124	37.7	68.6	TVD050M8-A	TVD050M8-B	124(2)	75.4	137.2
TVS030M8-A	TVS030M8-B	157	43.8	82.3	TVD060M8-A	TVD060M8-B	157(2)	87.6	164.6
TVS035M8-A	TVS035M8-B	189	50.9	95.1	TVD070M8-A	TVD070M8-B	189(2)	101.8	190.3
TVS040M8-A	TVS040M8-B	189	58.1	116.3	TVD080M8-A	TVD080M8-B	189(2)	116.2	232.6
TVS050M8-A	TVS050M8-B	254	64.6	122.8	TVD100M8-A	TVD100M8-B	254(2)	129.2	245.6
TVS015H8-A	TVS015H8-B	103	23.6	42.1	TVD030H8-A	TVD030H8-B	103(2)	47.2	84.2
TVS022H8-A	TVS020H8-B	103	32.3	61.5	TVD044H8-A	TVD040H8-B	103(2)	64.7	122.9
TVS025H8-A	TVS025H8-B	124	34.4	63.6	TVD050H8-A	TVD050H8-B	124(2)	68.9	127.1
TVS030H8-A	TVS030H8-B	157	40.5	77.2	TVD060H8-A	TVD060H8-B	157(2)	81.1	154.4
TVS035H8-A	TVS035H8-B	189	47.6	89.9	TVD070H8-A	TVD070H8-B	189(2)	95.3	179.9
TVS040H8-A	TVS040H8-B	189	56.5	112.8	TVD080H8-A	TVD080H8-B	189(2)	113.1	225.6
TVS011L 6/8-A	TVS013L 6/8-B	82	21.9	42.2	TVD021L 6/8-A	TVD025L 6/8-B	82(2)	43.9	84.5
TVS016L 6/8-A	TVS016L 6/8-B	103	29.1	58.4	TVD031L 6/8-A	TVD031L 6/8-B	103(2)	58.2	116.7
TVS023L 6/8-A	TVS021L 6/8-B	124	33.6	63.4	TVD045L 6/8-A	TVD041L 6/8-B	124(2)	67.1	126.8
TVS028L 6/8-A	TVS026L 6/8-B	157	43.8	82.3	TVD055L 6/8-A	TVD051L 6/8-B	157(2)	87.6	164.6
TVS031L 6/8-A	TVS031L 6/8-B	157	43.8	82.3	TVD061L 6/8-A	TVD061L 6/8-B	157(2)	87.6	164.6
TVS041L 6/8-A	TVS041L 6/8-B	189	51.3	95.8	TVD081L 6/8-A	TVD081L 6/8-B	189(2)	102.7	191.6
TVS016M8-A	TVS016M8-B	124	31.2	60.5	TVD031M8-A	TVD031M8-B	124(2)	62.4	120.9
TVS021M8-A	TVS021M8-B	124	37.8	75.4	TVD041M8-A	TVD041M8-B	124(2)	75.6	150.9
TVS023M8-A		124	40.5	79.0	TVD045M8-A		124(2)	81.0	158.0
TVS026M8-A	TVS026M8-B	157	45.8	89.8	TVD051M8-A	TVD051M8-B	157(2)	91.7	179.6
TVS031M8-A	TVS031M8-B	189	53.9	111.4	TVD061M8-A	TVD061M8-B	189(2)	107.9	222.7
TVS036M8-A	TVS036M8-B	254	78.7	181.2	TVD071M8-A	TVD071M8-B	254(2)	157.4	362.3
TVS041M8-A	TVS041M8-B	254	93.0	228.9	TVD081M8-A	TVD081M8-B	254(2)	186.1	457.8
TVS051M8-A	TVS051M8-B	254	93.0	228.9	TVD101M8-A	TVD101M8-B	254(2)	186.1	457.8
TVS016H8-A	TVS016H8-B	124	31.7	60.2	TVD031H8-A	TVD031H8-B	124(2)	63.3	120.3
TVS021H8-A	TVS021H8-B	124	37.2	73.9	TVD041H8-A	TVD041H8-B	124(2)	74.5	147.8
TVS026H8-A	TVS026H8-B	157	42.6	84.5	TVD051H8-A	TVD051H8-B	157(2)	85.2	169.0
TVS031H8-A	TVS031H8-B	189	50.7	105.6	TVD061H8-A	TVD061H8-B	189(2)	101.4	211.3
TVS036H8-A	TVS036H8-B	254	77.8	177.5	TVD071H8-A	TVD071H8-B	254(2)	155.5	355.0
TVS041H8-A	TVS041H8-B	254	91.5	223.6	TVD081H8-A	TVD081H8-B	254(2)	183.0	447.2
TVS051H8-A	TVS051H8-B	254	91.5	223.6	TVD101H8-A	TVD101H8-B	254(2)	183.0	447.2
	TVS008V6-B	70	19.0	34.2		TVD016V 6/8-B	70(2)	38.1	68.5
	TVS012V6-B	82	23.8	44.0		TVD024V 6/8-B	82(2)	47.7	88.0
	TVS016V6-B	82	23.8	44.0		TVD032V 6/8-B	82(2)	47.7	88.0
	TVS020V6-B	124	33.6	62.5		TVD040V 6/8-B	124(2)	67.1	125.0
	TVS025V6-B	124	33.6	62.5		TVD050V 6/8-B	124(2)	67.1	125.0
	TVS030V6-B	124	36.4	72.8		TVD060V 6/8-B	124(2)	72.7	145.7

† NOTE ON ALTERNATE REFRIGERANTS: PUBLISHED RECEIVER CAPACITY IS
BASED ON R404A ON MODELS USING "8" AS REFRIGERANT CODE.
FOR ALTERNATE REFRIGERANTS, MULTIPLY R404A VALUE
BY THE APPROPRIATE VALUE AT RIGHT:

R407A	R407C	R448A	R507	R22
1.10	1.10	1.05	1.00	1.15

- For R449A, use R448A data.

WEIGHT OF REFRIGERANT

Weight of Refrigerant in Copper Tubing (Lbs)

Pipe O.D. in inches	Cubic ft. per 100 ft.	R404A		R407A		R407C		R448A		R22		R134a	
		Lbs per 100 feet of type L tubing - Weight at 75°F/28.89°C											
		L	V	L	V	L	V	L	V	L	V	L	V
		65.51	3.94	71.8	3	71.31	2.64	68.5	2.93	74.6	2.68	75.59	1.95
3/8	0.054	3.5	0.2	3.9	0.2	3.9	0.1	3.7	0.2	4.0	0.1	4.1	0.1
1/2	0.101	6.6	0.4	7.3	0.3	7.2	0.3	6.9	0.3	7.5	0.3	7.6	0.2
5/8	0.162	10.6	0.6	11.6	0.5	11.6	0.4	11.1	0.5	12.1	0.4	12.2	0.3
7/8	0.336	22.0	1.3	24.1	1.0	24.0	0.9	23.0	1.0	25.1	0.9	25.4	0.7
1- 1/8	0.573	37.5	2.3	41.1	1.7	40.9	1.5	39.3	1.7	42.7	1.5	43.3	1.1
1- 3/8	0.873	57.2	3.4	62.7	2.6	62.3	2.3	59.8	2.6	65.1	2.3	66.0	1.7
1- 5/8	1.235	80.9	4.9	88.7	3.7	88.1	3.3	84.6	3.6	92.1	3.3	93.4	2.4
2- 1/8	2.149	140.8	8.5	154.3	6.4	153.2	5.7	147.2	6.3	160.3	5.8	162.4	4.2
2- 5/8	3.314	217.1	13.1	237.9	9.9	236.3	8.7	227.0	9.7	247.2	8.9	250.5	6.5
3- 1/8	4.731	309.9	18.6	339.7	14.2	337.4	12.5	324.1	13.9	352.9	12.7	357.6	9.2
3- 5/8	6.398	419.1	25.2	459.4	19.2	456.2	16.9	438.3	18.7	477.3	17.1	483.6	12.5
4- 1/8	8.317	544.8	32.8	597.2	25.0	593.1	22.0	569.7	24.4	620.4	22.3	628.7	16.2
5-1/8	12.98	850.3	51.1	932.0	38.9	925.6	34.3	889.1	38.0	968.3	34.8	981.2	25.3
6-1/8	18.63	1220	73.4	1338	55.9	1329	49.2	1276	54.6	1390	49.9	1408	36.3

Note:

- L = Liquid, V = Vapor
- For R507 use R404A
- For 449A use R448A.

COMPRESSOR OILS

Copeland Compressors

REFRIGERANT	LUBRICANT CHOICES		
	PREFERRED *	ALTERNATE 1	ALTERNATE 2
HCFC R401A HCFC R-401B HCFC R-402A HCFC R-402 HCFC R-408A HCFC R-409A	AB & MIN	POE-32 & MIN	POE-32
HFC R134a HFC R404A HFC R507 HFC R407A HFC R407C HFC R448A HFC R-407F	POE-32	n/a	n/a

*** LEGEND:**

MIN: Mineral Oil (Copeland® 46BWMO, Sonneborn Suniso 3GS), Chevron/Texaco Capella WF32)
 Mineral oils are interchangeable for 'top off' purpose
 AB: Alkyl Benzene Oil (Copeland® Ultra 200, Shrieve Zerol 200 TD, Sonneborn Suniso AKB200A, Shell 2212)
 POE 32: Polyolester Oil (Copeland® Ultra 32-3MAF, National NL PE32-3MAF, Lubrizol Emkarate RL32-3MAF, Parker EMKARATE, RL32-3MAF/ (Virginia) LE323MAF, Nu Calgon 4314-66 (EMKARATE RL32-3MAF)
 Spectronics AR-GLO 4/E Fluorescent Leak Detection Dye is approved for HFC/POE and HCFC/Mineral Oil usage at the manufacturer's recommended concentrations

Bitzer Semi-Hermetic Reciprocating Compressors: 2KC-05.2(Y) to 6F-50.2(Y)

Lubricant Type		(H)CFC R22 Interim Blends R-401A, R-401B, R-402A, R-408A, R-409A, (MP-39, MP-66, HP-80, FX-10, FX56)	HFC's R134a R404A R507 R407C R407A R448A
Polyol Ester	ICI (Virgina KMP) Emkarate RL32S	A*	P
	Mobil EAL Arctic 32	A*	P
	Castrol Icematic SW32	A*	P
Mineral Oils	Suniso 3GS	A	Not Acceptable
	Suniso 4GS	A	
	Capella Oil WF32	A	
	Capella Oil WF68	A	
	Esso Zerice R68	A	
Alkyl Benzene	Zerol 150	P	Not Acceptable
	Zerol 300	P	
	Icematic 2284	P	
	Esso Zerice S46	P	
	Esso Zerice S68	P	
A/B M/O Mix	Shell Clavus SD 2212	P	Not Acceptable
	Esso Zerice R46	A	

Legend: P = Preferred

A= Acceptable Alternative

- Compressor with "Y" designation are factory charged with polyolester oil

* NOTE: When operating (H)CFC with ester oils the quantity of refrigerant dissolved in the oil is more than doubled as compared with conventional lubricants. Special care should be taken. Refer to Bitzer Technical Bulletin KT-510-2, section 5 for additional information.

WATER-COOLED CONDENSERS

WARNING

All water and drain connections to the unit must be made in accordance with national as well as local plumbing codes and by-laws.

All water-cooled condensers require a water regulating valve that must be installed upstream of the condenser. The water-regulating valve is adjustable and is set to provide the desired condensing pressure. As the condensing pressure rises, the valve will open and allow more water to flow. As the condensing pressure lowers, the valve will start to close to reduce the amount of water flow into the condenser. Typical condensing temperatures normally range between 90 to 110 °F. The actual water inlet temperature and water supply flow capacity available at the site determines the suitable condensing temperature. Lower inlet water temperatures (40°F to 70 °F) allow the condensing unit to run at a lower condensing temperature (70°F to 90°F). Higher water inlet temperatures (above 85°F) require the condensing temperature to be higher (105° to 120°F). The capacity of the water-cooled condensing unit varies with condensing temperature. Refer to the water flow rate chart in the Product Data and Specifications brochure that comes with the condensing unit to estimate the required flow rate in GPM. If water supply pressure is excessive, a pressure-reducing valve must be used since the allowable working pressure of water valves and condensers is normally 150 psig (1136 kPa).

Care should be exercised in locating the condensing unit so that the condenser will never be exposed to temperatures below freezing.

Excessive water velocities or cavitation on the waterside of the condenser tubes may damage a water-cooled condenser. In order to prevent operating difficulties, care should be taken to follow the instructions outlined below:

- (a) Water velocities through the condenser should not exceed 7 fps (2.13 m/s). Higher velocities can result in "impingement corrosion". In order to maintain water velocities at an acceptable level, parallel circuiting of the condenser may be necessary when high water flow is required.
- (b) If a water-circulating pump is used, it should be installed so that the condenser is fed from the discharge side of the pump.
- (c) If the condenser is installed more than 5 ft (1.52 m) higher than the outlet drain point of the condenser, a vacuum breaker or open vent line should be provided to prevent the outlet line from creating a partial vacuum condition.

RECOMMENDED OPTIONS

Low Temperature Systems (-10°F Freezers)

- Suction Accumulator*
 - with Heat Exchanger*
- Oil Separator*
- Suction Filter

Medium Temperature Systems (+35°F Coolers)

- Suction Accumulator
 - with Heat Exchanger
- Oil Separator
- Suction Filter

Long Piping Runs (>100-150 ft)

- Suction Accumulator*
 - with Heat Exchanger*
- Oil Separator*
- Oversized Receiver*
- Liquid / Suction Heat Exchanger*
- Suction Filter

Capacity Control (Expected Periods of Low Load / Oversized Equipment to Daily Load Requirements / Tight Temperature Control)

• Hot Gas Bypass to Evaporator (for use with 1 evaporator)

Add

- Aux Sideport Connector to evaporator (required)
- HG Bypass to Evaporator Kit (required)

• Hot Gas Bypass to Suction (for use with multiple evaporators or where bypass to evaporator is not accessible/realistic)

Add

- Suction Accumulator (required)
- HG Bypass to Suction Line Kit (required)

* Highly recommended

AVAILABLE OPTIONS & OPTION INFORMATION

HOT GAS BYPASS

Purpose:

To maintain a constant evaporating pressure during periods of low load either to prevent coil icing or to avoid operating the condensing unit at a lower suction pressure than it was designed to operate.

Application:

Hot gas bypass is a method of compressor capacity control that eliminates the on-off control of the compressor allowing for greater control of temperature, humidity and load matching. Common uses are in wine rooms, fur storage and biotech; anywhere critical temperature and/or humidity applications exist.

How it Works:

The discharge bypass valve is located in a branch line off the discharge line close to the compressor. The bypassed hot gas can enter the low side at the inlet of the evaporator or at the suction line. The hot gas bypass valve is adjustable to maintain the desired evaporating or suction pressure. Maintaining a constant evaporating pressure regulated by the modulating hot gas will allow for a constant coil temperature resulting in a constant room temperature regardless of room load.

Bypass to Inlet of the evaporator is the preferred method because the TXV will provide the correct amount of liquid refrigerant for desuperheating. In addition, the evaporator allows for proper mixing of liquid and hot gas ensuring dry super-heated refrigerant returns to the compressor.

Bypass to the suction line is used with long line runs and with multiple evaporators. The addition of a specific desuperheating TXV is required to prevent overloading (overheating) of the compressor due to high return gas temperatures caused by bypassed hot gas close to the compressor. A suction accumulator is also recommended, as this will ensure proper mixing of the hot gas and liquid refrigerant prior to it reaching the compressor.

CRANKCASE PRESSURE REGULATOR (CPR)

Purpose:

Prevents overloading of the compressor motor by limiting the suction pressure at the compressor during normal operation, during or after defrost, or after a lengthy shutdown period.

Application:

Required on any application where the potential for the compressor running at a suction temperature or pressure higher than what is allowed by the compressor manufacturer (i.e. running the compressor outside its operating envelope) for an extended period of time. This can be seen on low temperature systems using hot gas defrost. High suction pressure and temperatures will overload the compressor motor causing the internal motor overload to open, stopping the compressor until it cools down.

How it works

A crankcase pressure regulator is a valve that closes on a rise of outlet pressure. The valve set point is the corresponding pressure of the maximum saturated suction

temperature the compressor manufacturer allows for the specific compressor. If the suction pressure upstream of the valve exceeds the set point, it begins to close modulating and maintaining a constant pressure for the compressor.

Please note that the use of a CPR valve introduces a large pressure drop in the suction line. Even under normal operating conditions a full 2°F drop may occur across the valve; reducing the refrigeration system capacity. A CPR valve set point lower than the maximum saturated suction temperature will prolong the pull-down period after a defrost has completed.

HEATED AND INSULATED RECEIVER

Purpose:

Heated and Insulated Receivers are used to maintain a minimum receiver pressure.

Application:

Applicable for outdoor units where mild to low ambient temperatures combined with extended off cycles (low product load) are experienced.

How it works:

Heated and insulated receivers help maintain a higher pressure that would normally correspond to the cold ambient/low pressure in the receiver. Without a heated and insulated receiver the pressure in the receiver would drop to the corresponding ambient temperature during off cycles (low product load conditions) upon a call for cooling the receiver pressure will be too low to feed the expansion valve. This would result in short cycling on the low pressure switch which could eventually lead to oil loss and compressor damage.

REPLACEABLE SUCTION FILTER

Purpose:

To pick up and remove system contaminants such as metal particles, rust, oxides, dirt, and any other solid contaminants. The suction filter protects compressors from materials becoming imbedded in the motor windings where the natural flexing of windings during start up can cause particles to scrape the motor insulation and result in motor burnout. Also used with desiccant cores (filter-drier) to collect and remove acid, moisture and sludge.

Application:

Required for field built up systems where cutting and/or brazing of lines occurs or additionally any system where contamination could or could have occurred.

Desiccant core suction filter-driers can be used to clean the system (removing corrosive acids) after mild hermetic motor burnouts. Filter-driers are also used to remove system moisture as system moisture could freeze TX valves and ultimately lead to liquid flood back and compressor damage.

AVAILABLE OPTIONS & OPTION INFORMATION (cont'd)

REPLACEABLE SUCTION FILTER (cont'd)

How it works:

The suction filter (filter-drier) is simply a shell with pleated or felt element used to collect contaminants. The suction filter is installed in the suction line and the filter core itself can be of sealed type or replaceable type where it can be removed and have a replaceable core. The core itself can be combined with or made out of a desiccant material for moisture removal.

REPLACEABLE LIQUID FILTER/DRIER

Same application as suction line filter/drier but installed in the liquid line. *See Replaceable Suction Filter.*

SUCTION ACCUMULATOR w/ HEAT EXCHANGER

Purpose:

To prevent liquid refrigerant from flooding back to the compressor as liquid flood back can result in liquid slugging, loss of oil from the crankcase or bearing washout. Note: liquid flood back is considered one of the major causes of compressor failure.

The addition of a heat exchanger raises the temperature of the return gas in the suction line and lowers the temperature of the refrigerant in the liquid line. This prevents the formation of flash gas in the liquid line, provides additional superheat to the suction gas helping to prevent liquid refrigerant from flooding back to the compressor and increasing system capacity.

Application:

Suction accumulators are used for any instances where liquid flood back could occur. Commonly used in low temperature systems where flood back is an increased issue.

How it works:

Suction accumulators are installed in the suction line close to the compressor. The accumulator is vertical container with top inlet and outlet connections. An internal U-tube connected only to the outlet reaches down near the bottom of the container and draws refrigerant in from the top. This allows the accumulator to almost completely fill with liquid refrigerant before flood back can occur. A small diameter hole is drilled in the U-tube near the lowest point. This small hole allows for controlled metering of liquid refrigerant or oil back to the compressor by a siphoning action.

ADJUSTABLE FLOODED HEAD PRESSURE CONTROL

Purpose:

To maintain the minimum required condensing pressure during periods of low ambient temperatures.

Application:

Any air cooled condenser exposed to ambient temperatures that fall below 65°F.

How it Works:

Liquid refrigerant is restricted from leaving the condenser to the receiver. This backs up liquid refrigerant into the

condenser reducing condenser area, which in turn increases condensing pressure. At the same time hot discharge gas can be bypassed around the condenser by means of the ORD (open on rise of differential) raising the liquid pressure in the receiver allowing the system to operate properly. The ORI (Open on Rise of Inlet pressure) is adjustable; its set point will maintain the condensing pressure in low ambient conditions. The ORD opens when the pressure drop between the inlet of the condenser and the outlet of the ORI exceeds approximately 20 PSI. The function of the ORD is to maintain receiver pressure to allow for adequate differential pressure across the TXV for proper operation of the TXV.

DISCHARGE LINE CHECK VALVE

Purpose:

To prevent the migration of liquid refrigerant from the condenser back to the compressor during the off cycle.

Application:

During long off cycle periods and combined with cold ambient temperatures, liquid refrigerant in the condenser may migrate to the compressor. The compressor may not be able to overcome the initial static head if liquid refrigerant is in the discharge line or worse if backed up right to the discharge valves. The valves in the head of the compressor may also leak the liquid into the crankcase causing a flooded start when the compressor eventually starts up. When the scroll compressor stops, high and low side equalize within the compressor. The discharge check valve will maintain the high/low side differential pressure during the compressor off cycle.

How it Works:

A check valve allows flow in one direction only. A discharge check valve will allow refrigerant to pass from the compressor to the condenser. It will not allow refrigerant to flow back through the valve from the condenser to the compressor.

EXTENDED LEG KIT

Purpose:

To raise the condensing unit off the ground by 8 inches

Application:

Leg kits are required in locations with high snow accumulation, areas common to flooding etc. Used where a requirement exists to keep the base of the condensing unit off the ground. This may prevent damage to components within the cabinet.

AVAILABLE OPTIONS & OPTION INFORMATION (cont'd)

OIL SEPARATOR W/ OIL RETURN SOLENOID

Purpose:

Oil Separators are used to return oil to the compressor.

Application:

Used on refrigeration systems where it's difficult to return oil to the compressor. Commonly used in low temperature systems where oil return is an increased issue.

How it Works:

Oil separators are installed in the compressor(s) discharge line. They are usually a vertical container with the discharge gas connections at the top and an oil return port at the bottom. Internal to the oil separator is a form of baffles (usually screen meshing) which removes oil by a means of velocity reduction. Most of the oil is removed from the refrigerant and returned to the compressor by means of a ball float valve

PUMP DOWN TOGGLE SWITCH

Purpose:

The purpose of the pump down cycle toggle switch is to force a pump down state. A pump down state prevents liquid migration to the compressor during off cycles which can lead to compressor oil loss and flooded starts.

Application:

Installed in systems where user controlled off cycles are used, common, or frequent.

How it Works:

The pump down switch is installed in series with the thermostat. When the pump down switch is thrown the power to the liquid line solenoid valve is lost and the solenoid goes into its powerless state of normally closed. With the liquid line solenoid valve closed the refrigerant flow to the evaporator is stopped and the compressor continues to run pumping refrigerant into the condenser and receiver until the low pressure control cuts out and the compressor contactor opens (stopping the compressor). The system will stay in a state of pump down that is the compressor running as required to pump down any refrigerant that might leak through the closed solenoid valve until the pump down switch is switched back.

PHASE/VOLTAGE MONITOR

Purpose:

Used to protect the compressor from voltage and/or phase imbalances.

Application:

Installed in areas where phase and voltage fluctuation is common or could occur.

How it Works:

Phase voltage monitor is installed to sense voltage and phase imbalance across the compressor contactor. Disconnects the power supplied to the compressor upon voltage and/or phase imbalance. Has a built in field adjustable restart delay (normally factory preset to 2 seconds).

DISCONNECT SWITCH

Purpose:

To externally disconnect power to the system/unit

Application:

A disconnect switch is used such power can easily be accessed and removed from the unit.

How it Works:

Disconnect switch is available with and without fusing and is a manual throw switch.

CONTROL CIRCUIT TRANSFORMER

Purpose:

Control circuit transformers are used to convert the unit supply voltage to a lesser voltage for use in the control circuit.

Application:

Used when supply voltage is large and a lower voltage is required or to allow for smaller electrical components.

COMPRESSOR CIRCUIT BREAKER

Purpose:

To disconnect power and provide branch circuit protection to the compressor

Application:

A compressor circuit breaker is used to provide branch circuit protection disconnect power from the compressor.

GOLD COAT FINIS

Purpose:

To protect the aluminum fins from corrosion in specific environmental applications.

Application:

Any aluminum fin coil exposed to a sodium rich environment such as fish coolers & freezers and salt water coast lines.

How it Works:

This is an aluminum fin that has a gold coloured coating applied at the aluminum manufactures facility. The micro thin coating is adhered to the aluminum fin protecting the aluminum from corrosion and material degradation from airborne contaminants that accumulate on the coil surface during the units operating cycle.

HERESITE COATING

Purpose:

To protect from exposure to corrosive atmospheres with the exception of strong alkalis, strong oxidizers and wet bromine, chlorine and fluorine in concentrations greater than 100 ppm

Application:

For both fins and units in corrosive atmospheres

How it Works:

This is a Heresite baked phenolic compound coating and is offered as a service to the customer. As standard the Heresite coating is applied to the coil and manifold only for additional protection.

AVAILABLE OPTIONS & OPTION INFORMATION (cont'd)

A419 ELECTRONIC THERMOSTAT

Purpose:

To provide users with an easy to read, easy to access, and single point reliable solid-state control thermostat.

Application:

The digital thermostat can be used where a thermostat is required separate of the evaporator(s). It is often used in circumstances having multiple evaporators in order to provide single point control from an easy to access location that can be either inside or outside the space. The digital thermostat with LCD display is used to more accurately set, read and control system temperatures and offers a tighter range differential.

How it Works:

This is a single stage, electronic temperature control with a single pole double throw output relay. Has LCD display with adjustable set point, differential and adjustable anti-short cycle delay. A419 is available in 120/240 VAC. Is wired in series with the liquid line solenoid valve(s) such that upon satisfying the cooling load the thermostat cuts out (de-energizing/closing the liquid solenoid valve) and pumping down the system. The electronic thermostat also offers a tighter range of control as the differential setting can be as low as 1°F (standard mechanical Saginomiya thermostat has a minimum differential of 3.6°F).

ELECTRONIC THERMOSTAT

Purpose:

To provide users with an easy to read, easy to access, and single point reliable solid-state control thermostat.

Application:

The digital thermostat can be used where a thermostat is required separate of the evaporator(s). It is often used in circumstances having multiple evaporators in order to provide single point control from an easy to access location that can be either inside or outside the space. The digital thermostat with LCD display is used to more accurately set, read and control system temperatures and offers a tighter range differential.

How it Works:

This is a single stage, electronic temperature control with a single pole double throw output relay. Has LCD display with adjustable set point, differential and adjustable anti-short cycle delay. Most electronic thermostats are available in 120/240 VAC. Is wired in series with the liquid line solenoid valve(s) such that upon satisfying the cooling load the thermostat cuts out (de-energizing/closing the liquid solenoid valve) and pumping down the system. The electronic thermostat also offers a tighter range of control as the differential setting can be as low as 1°F.

EC MOTORS (Electronically Commutating Motors)

Purpose:

To comply with regional regulatory code as well as provide increased energy efficiency and decreased operational costs

Application:

EC Motors are required in most regions by local codes and regulations. Used to provide increased energy efficiency and as such lower operating cost (compared to Shaded Pole or PSC motors).

How it Works:

An EC motor is made up of two components, the motor and the motor control module. Input AC voltage is supplied and converted to DC voltage by the motor control module. This DC voltage is used in the brushless operation of the motor. The motor controller energizes the motor phases at the appropriate time for optimum operation and speed. The motor controller can be programmed to provide specific speed based on a 0-10V input signal.

Note: our standard EC evaporator motors are set up for 1 speed or 2 speed operation with SmartSpeed. EC motors due to brushless commutation and internal controller are significantly more efficient than standard motors. Installed PSC motor efficiencies are typically in the range of 12-45% whereas EC motors maintain an efficiency of 65-72% at all speeds. In addition to EC motor efficiency; these motors operate at low temperatures requiring less energy to offset motor heat gain in the refrigeration system.

FOR DETAILS ON EC MOTOR APPLICATION REFER TO EC MOTOR APPLICATION GUIDE

COMPRESSOR TIME DELAY (Delay on Break)

Purpose:

To provide a specified amount of time for the compressor to remain off after pump down and prevent short cycling.

Application:

Installed on condensing units to prevent short cycling and protect the compressor. (Factory setting 3-minutes)

How It Works:

Immediately upon application of power, the **Delay on Break timer** enables circuit operation. Once power is interrupted, the circuit opens for the **time** set on the dial. After the **time** period elapses, the circuit closes, allowing the protected motor or compressor to start.

LEAK TESTING

IMPORTANT: All system piping, including the condensing unit and accessories should be thoroughly tested for leaks prior to start up and charging. The system should be initially pressurized to a maximum of 150 psig (1136 kPa) with dry nitrogen to ensure that the system is free of major leaks. With the system free of major leaks, a more detailed leak check should be performed. Discharge the initial dry nitrogen charge and add enough refrigerant to raise the system pressure up to 10 psig (170 kPa) (tracer amount). Add dry nitrogen to increase the system pressure to a maximum of 150 psig (1136 kPa). It is recommended that an electronic leak detector be used when checking for leaks because of its greater sensitivity to small leaks. As a further check it is recommended that this pressure be held for a minimum of 12 hours and then rechecked. The system must be leak free for satisfactory operation.

WARNING

HFC-134a has been shown to be combustible at pressures as low as 5.5 psig (140 kPa) at 350 °F (176.7 °C) when mixed with air at concentrations more than 60% air by volume. At lower temperature, higher pressures are required to support combustion. Therefore, air should never be mixed with HFC-134a for leak detection.

IMPORTANT ENVIRONMENTAL NOTE

When conventional leak detection methods are employed using HCFC or CFC tracer gas, all of the tracer gas must be reclaimed and disposed of in a proper manner.

EVACUATION AND DEHYDRATION

When the system is completely free of refrigerant leaks, an evacuation of the entire system should be completed by using a “high vacuum” pump. This evacuation, if completed correctly, will ensure long life for the system as well as elimination of moisture and non-condensable gas problems. **Moisture problems causing compressor failure will void warranty. Follow the recommended procedure carefully.**

CAUTION

Do not use the refrigeration compressor to evacuate the system. Never start the compressor or perform a megger insulation test while the system is in a vacuum.

DEHYDRATION PROCEDURE

1. Use larger size (3/8 or 1/2) hoses or copper lines.
2. Perform oil change on vacuum pump at the beginning of each evacuation
3. Always check vacuum pump, manifold, and hose assembly that it will pull below 250 microns.
4. Evacuate system from 4 access points (if available) on the system. These points are: (Refer to piping schematic below)
 - i. Liquid receiver service valve (VL1)
 - ii. Compressor Suction service valve (VL2)
 - iii. Compressor Discharge service valve (VL3)
 - iv. ¼ fitting on Discharge line before the condenser (VL4)
5. Ensure that all solenoids in the system are open (energized) during evacuation.
6. Ensure that all ball valves in the system are open and all service valves are appropriately cracked or back-seated during evacuation.
7. Perform “Deep Vacuum Method”.

DEHYDRATION PROCEDURE (cont'd)

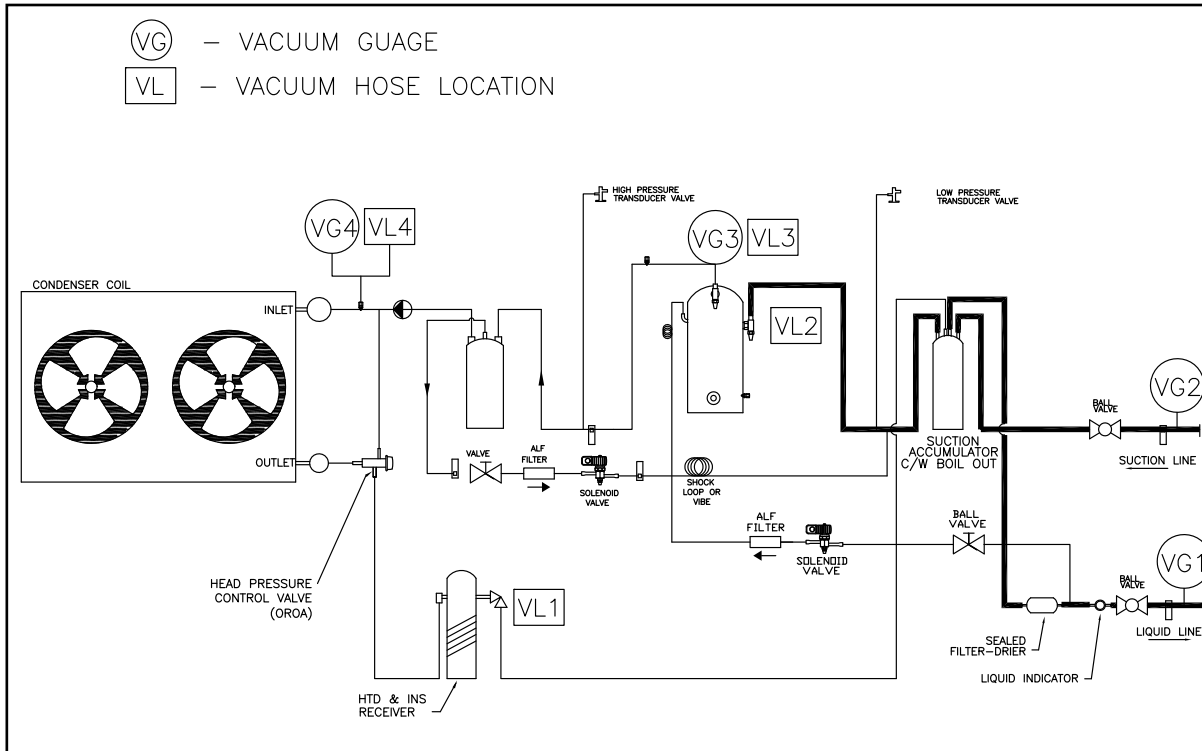

Deep Vacuum Method:

1. Ensure that the vacuum pump used is capable of pulling a 250 micron vacuum.
2. Connect hoses to the appropriate locations on the system and other ends to the manifold. Then connect the manifold to the vacuum pump.
3. Connect an electronic vacuum gauge at a point on the system furthest away from the vacuum pump.
4. Turn on the vacuum pump and proceed with opening the high and low side valves on the gauge manifold first then proceed with opening the shut off valves or service valves which gives access to the system.
5. Evacuate until the vacuum gauge reads 500 microns or less.
6. Close the valves to the vacuum pump and shut pump off. Wait 30 minutes.
7. If the vacuum gauge reads below 1000 microns the system can be considered dry and leak free and can proceed with refrigerant charging.
8. If the vacuum gauge reads between 1000-2000 microns then some moisture is still present. Sweep with Nitrogen and repeat steps 4-7.

Refer to graph below as a guideline when using the Deep Vacuum Method.

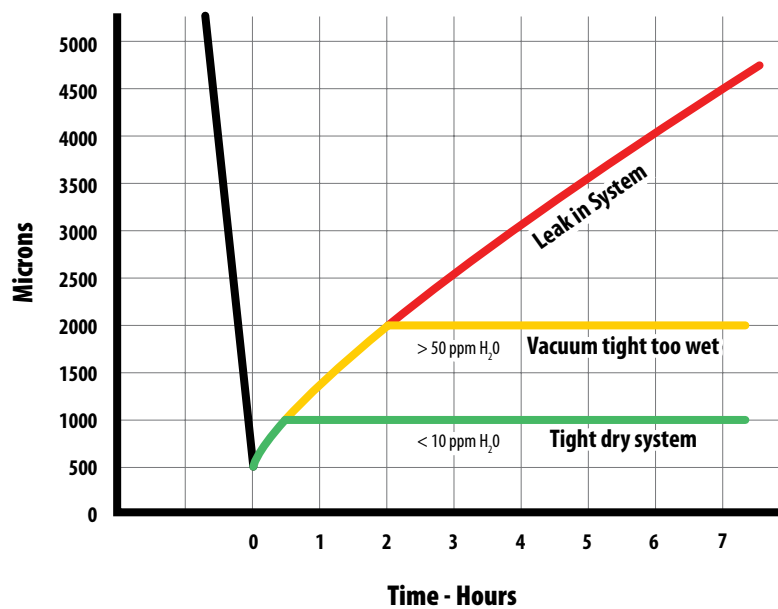

SYSTEM START-UP CHECK LIST

IMPORTANT START-UP NOTE

Only a qualified refrigeration mechanic who is familiar with compressor performance and the function and adjustment of all controls and components should start up the compressor. Finishing up work on the installations should be planned so that a qualified mechanic is on the job for at least the first full day that the unit is in operation.

Before any refrigeration system is started, the following items should be checked:

- (1) Check that all electrical and refrigeration connections are tight.
- (2) Check compressor crankcase oil level (if equipped with sight glass). It should be from 1/8 to 1/2 full in the sight glass.
- (3) Insure that compressor shipping spacers (spring mounted compressors) or hold down nut (solid mounted compressors) are properly in place.
- (4) Check that the compressor discharge and suction shut-off valves are open.
- (5) Ensure that the high and low pressure controls pressure regulating valves, oil pressure safety controls, Compressor Time Delay and any other safety controls are adjusted properly.
- (6) Check that the room thermostat is set for normal operation and adjust if required.
- (7) Check all motors, fans and pump bearings in the condenser and evaporator. If they are the type that require oil or grease, make sure that this is attended to in accordance with the tag, which will be attached. Fan blades and pumps should be checked for correct rotation, tightness and alignment. Air should draw air through the condenser (air cooled condensing unit models).
- (8) Electric and hot gas evaporator fan motors should be temporarily wired for continuous operation until the room temperature has stabilized.
- (9) Observe the system pressures during the charging and initial operation process. **DO NOT** add oil while the system is low on refrigerant charge unless the oil level is dangerously low.
- (10) Continue to charge the system until it has enough charge for proper operation. **DO NOT OVERCHARGE THE SYSTEM.** Note that bubbles in the sight glass may not necessarily mean a shortage of refrigerant.
- (11) **DO NOT** leave the system unattended until the system has reached its normal operating condition and the oil charge has properly adjusted itself to maintain the proper level in the sight glass.
- (12) Compressor performance, and that of all of the moving components should be watched carefully throughout the first operating cycle and then checked periodically during the first day of operation. **Careful attention to details at this time will pay dividends in trouble-free performance of the entire system.**
- (13) Check that the wiring diagrams, instructions bulletins etc. are read and attached to the unit for future reference.

WARNING

Three phase scroll compressors must be checked for correct rotation. During the initial start up, observe the suction and discharge gauges to ensure the suction pressure drops and the discharge pressure rises.

PRESSURE CONTROLS

Encapsulated Pressure Switches

Encapsulated pressure switches are commonly installed on many condensing units. These switches set with fixed set points (non-adjustable) and are auto reset.

- High Pressure Switch: R22 Cut-out @ 350 PSIG, Cut-in @ 250 PSIG
R404A/R507/R448A/R407A/R407C Cut-out @ 400 PSIG, Cut-in @ 300 PSIG

Adjustable Pressure Controls

Adjustable Low Pressure Control Settings **

Minimum Temperature °F *	R134a		R22		R404A R507		R448A R407A R407C	
	Cut-in (PSIG)	Cut-out (PSIG)	Cut-in (PSIG)	Cut-out (PSIG)	Cut-in (PSIG)	Cut-out (PSIG)	Cut-in (PSIG)	Cut-out (PSIG)
50	35	5	70	20	85	30	65	20
40	25	5	55	20	70	30	50	20
30	17	5	40	20	50	30	35	20
20	12	0	30	10	40	20	25	5
10	7	0	20	0	30	10	15	0
0	5	0	15	0	20	5	10	0
-10	-	-	15	0	15	0	10	0
-20	-	-	10	0	10	0	7	0
-30	-	-	10	0	6	0	7	0

* The coldest Temperature of either the fixture or outdoor ambient.

** Compressor Time Delay Setting: 3 Minutes

Adjustable High Pressure Control Settings

Refrigerant	Maximum Cut-out (PSIG)	
	Air-Cooled Units	Water Cooled Units
R134a	250	200
R22	350	315
R404A R448A R407A R407C	400	315

LOW TEMPERATURE ROOM PULL-DOWN

It can take up to two weeks to properly start-up and pull-down a large freezer. Large freezers should be pull-down to temperature in stages. Too fast a pull-down can cause structural problems in pre-fabricated rooms and will damage (crack) concrete floors. Reduce room temperature by 10 to 15°F (5.6 to 8.4°C) per day. Hold this temperature for 24 to 48 hours at 35°F (1.7 °C) and again at 25°F (-3.9 °C). Monitor the amount of defrost water during this pull down stage.

Once the room is pulled down to temperature, expect frost on the compressor end bell and any exposed suction line. A lack of frost in these areas probably indicates too high of suction superheat. Reduce defrost frequency to 30 minutes every 6 hours if possible. Adjust the defrost termination (and time clock) so that the coil and drain pan are **COMPLETELY** free of frost / ice at termination. Too short of a defrost cycle will allow residual ice to grow. Too long of a defrost will allow the coil(s) to steam at the end of the cycle. The steam will condense and freeze fans, fan guards and create frosting on the ceiling of the room. The evaporator fan delay must allow any condensate left on the coil surface to refreeze before the fans start.

CHECKING SUPERHEAT

IMPORTANT SYSTEM BALANCING NOTE

To obtain maximum system capacity and insure trouble free operation it is necessary to check both the compressor and evaporator superheat.

Compressor Superheat

Compressor suction superheat must be checked. To check the superheat at the compressor the following steps should be followed:

- (1) Measure the suction pressure at the suction service valve of the compressor. Determine the saturated temperature corresponding to this pressure from a "Pressure- Temperature" chart.
- (2) Measure the suction temperature of the suction line about 6 inches (15 cm) back from the compressor suction valve using an accurate thermometer.
- (3) Subtract the saturated temperature (from step 1) from the actual suction line temperature (from step 2). This difference is the **actual superheat at the compressor**.

System capacity decreases as the suction superheat increases. For maximum system capacity, the suction superheat should be kept as low as is practical. The superheat at the compressor should range within 20 to 45 °F (11.2 to 25.2 °C) Superheat.

NOTE: Too low of a suction superheat can result in liquid being returned to the compressor. This can cause dilution of the oil and eventually cause failure of the bearings and rings through wash out as well as liquid slugging.

NOTE: Too high of a suction superheat will cause excessive discharge temperatures which cause a break down of the oil and will result in piston ring wear, piston and cylinder wall damage.

If adjustment to the suction superheat is required, it should be done either by adjusting the thermostatic expansion valve at the evaporator, the use of liquid to suction heat exchanger or suitable use of suction line insulation.

Evaporator Superheat

Once the refrigerated space is at its design temperature or close to design temperature, the evaporator superheat must be checked. To check the suction superheat at the evaporator the following steps should be followed:

- (1) Measure the suction pressure in the suction line at the bulb location by either,
 - (a) A gauge in the external equalizer line will indicate the pressure directly and accurately.
 - (b) A gauge directly in the suction line near the evaporator or directly in the suction header will suffice.
- (2) Measure the temperature of the suction line at the point where the thermostatic expansion valve bulb is clamped to the suction line.
- (3) Convert the pressure obtained in step 1 above to a saturated evaporator temperature from a "Pressure-Temperature" chart.
- (4) Subtract the saturated temperature (from step 1) from the actual suction line temperature (from step 2). This difference is the **actual superheat at the evaporator**.

The superheat at the evaporator should be a minimum of 6 to 10 °F (3.4 to 5.6 °C) for systems with a 10 °F (5.6 °C) design TD (temperature difference) to a maximum of 12 to 15 °F (6.7 to 8.4 °C) for systems with a higher operating TD.

Low temperature applications (freezers) should be set at superheats of 4 to 6 °F (2.2 to 3.4 °C).

TD = Box temperature – evaporating temperature.

SEQUENCE OF OPERATION

Recycling Pump Down System

1. Power is generally supplied to the thermostat and liquid line solenoid circuit from the evaporator fan terminals "4" & "F" (off time defrost) or from the time clock (timed air or electric defrost) terminals "4" and "N".
2. The room thermostat switch closes when the temperature rises above the desired set point.
3. The liquid line solenoid coil is energized causing the valve to open, allowing liquid refrigerant into the evaporator coil.
4. The low pressure control closes when the suction pressure rises above the cut-in setting of the control.
5. The compressor contactor coil is energized causing the contactor to close. The compressor and the condenser fan closest to the discharge header start at the same time. Additional fans will come on after the discharge pressure rises above the cut-in set point of the fan cycle control.
6. Once the thermostat set point has been reached, the thermostat opens and the liquid line solenoid coil is de-energized. The solenoid valve closes stopping the refrigerant flow to the evaporator.
7. The compressor continues to run reducing the suction pressure until it drops below the cut-out setting indicated on the low pressure control. The compressor contactor coil is de-energized, the contactor opens and the compressor and condenser fan stop running. The Compressor Time Delay opens for the recommended 3-minute setting to prevent short cycling.
8. The system remains off until the temperature rises above the desired set point again.

Electric Defrost Cycle – Using 8145 time clock or equivalent

1. During refrigeration the "4" terminal on the time clock is powered supplying voltage to the thermostat and solenoid circuit. It also supplies voltage to the evaporator fans directly or to a contactor coil whose contactor contacts directly power the evaporator fan motors.
2. During defrost the "3" terminal on the time clock is powered supplying voltage to the defrost heater circuit.
3. The defrost cycle starts automatically via the time clock at predetermined times as defined by the installing contractor by manipulating the pins on the clock face. Three (3) to four (4) defrost cycles are generally sufficient however variations in loads due to usage and infiltration may require additional adjustments, defrost cycles of alternative defrost methods
4. When it's time for a defrost cycle to start, terminal "4" is de-energized, the liquid line solenoid coil is de-energized. The solenoid valve closes stopping the refrigerant flow to the evaporator allowing the compressor to pump down and shut off on the low pressure control. At the same time the evaporator fan motors stop running. From the time clock terminal "3" is powered, however a normally closed auxiliary contact mounted on the side of the compressor contactor holds the off the power to the heater circuit until the compressor has finished pumping down.
5. Once the compressor contactor opens, the auxiliary switch closes supplying voltage to the defrost heaters directly or to a contactor coil whose contactor contacts directly power the defrost heaters.
6. Once powered, the defrost heaters increase the coil temperature melting the frost that had accumulated during the refrigeration cycle.
7. A defrost termination thermostat measures the coil temperature. Once the coil reaches 55°F +/-5°F the switch closes powering the "X" terminal on the evaporator which is field wired to the "X" terminal on the time clock. The time clock switches back into refrigeration mode, de-energizing terminal "3" and re-energizing terminal "4".
9. Assuming the room thermostat is closed, the liquid line solenoid coil is energized causing the valve to open allowing liquid refrigerant into the evaporator coil. The low pressure control closes when the suction pressure rises above the cut-in setting of the control. The compressor contactor coil is energized causing the contactor to close. The compressor and the condenser fan(s) start at the same time.
8. As the compressor runs the coil temperature will drop, the fan delay thermostat measures the coil temperature. The contacts of the fan delay thermostat will close completing the evaporator fan motor circuit back to "N" on the time clock causing the fans to start running again.
9. The system will now operate in the refrigeration cycle until another defrost period is initiated by the time clock.

SYSTEM OPERATIONAL CHECK LIST

When the system has been running trouble free for an extended time (two weeks or more) and design conditions are satisfied, the following check list should be followed:

- (1) Check that compressor **discharge and suction pressures** are operating within the allowable design limits for the compressor. If not, take the necessary corrective action.
- (2) Check the liquid line sight glass and expansion valve operation. If there is an indication that the system is low on refrigerant, thoroughly **check the system for leaks before adding refrigerant**.
- (3) Check the **level of the oil** in the compressor sight glass (if so equipped). Add oil as necessary.
- (4) The thermostatic expansion valve must be checked for **proper superheat settings**. The sensing bulb must have positive contact with the suction line and should be insulated. Valves operating at a high superheat setting results in low refrigeration capacity. Low superheat settings can cause liquid slugging and compressor bearing washout. (Refer to the section on compressor and evaporator superheats)
- (5) Check the **voltage and amperage** readings at the compressor terminals. Voltage reading must be within the recommended guidelines. Normal operating amperages can be much lower than the compressor nameplate values.
- (6) To check the **high pressure control setting** it is necessary to build up the head pressure to the cut-out point of the control. This can be done by stopping the condenser fan(s) (air cooled condensing units) or pump and watching the pressure rise on a high pressure gauge to make sure the high pressure control is operating at the setting.
- (7) Check the **low pressure settings** by throttling the compressor shut-off valve and allowing the compressor to pump down. This operation must be done with extreme caution to avoid too sudden a reduction in crankcase pressure, which will cause oil slugging and possible damage to the compressor valves. Close the valve a turn a time while watching the compound gauge for change and allowing time for the crankcase pressure to equalize with the pressure control bellows pressure. The slower the pressure is reduced, the more accurate will be the check on the pressure control setting.
- (8) Recheck all **safety and operating controls** for proper operation and adjust as necessary.
- (9) Check **defrost controls for initiation and termination settings**, and the length of defrost period. Set the fail safe on the time clock at the length of defrost plus 25 %.
- (10) If the system is equipped with winter head pressure controls (fan cycling or flooded valves), **check for operation**. See details on page 14 for flooded valves.
- (11) Fill in the **Service Log** in the back of this Installation Manual.

SYSTEM TROUBLESHOOTING

The following System Troubleshooting Guide lists the most common types of malfunctions encountered with refrigeration systems. These simple troubleshooting techniques can save time and money minimizing unnecessary downtime and end-user dissatisfaction.

Contact the factory or your local sales representative for further information or assistance.

System Troubleshooting Guide	
Condensing Unit Problem	Possible Causes
Compressor will not run. Does not try to start.	<ol style="list-style-type: none"> 1. Main power switch open. 2. Fuse blown or tripped circuit breaker. 3. Thermal overloads tripped. 4. Defective contactor or coil. 5. System shut down by safety devices. 6. Open thermostat or control. No cooling required. 7. Liquid line solenoid will not open. 8. Loose wiring.
Compressor hums, but will not start.	<ol style="list-style-type: none"> 1. Improperly wired. 2. Low line voltage. 3. Loose wiring. 4. Defective start or run capacitor. 5. Defective start relay. 6. Motor windings damaged. 7. Internal compressor mechanical damage.
Compressor starts, but trips on overload protector.	<ol style="list-style-type: none"> 1. Improperly wired. 2. Low line voltage. 3. Loose wiring. 4. Defective start or run capacitor. 5. Defective start relay. 6. Excessive suction or discharge pressure. 7. Tight bearings or mechanical damage in compressor. 8. Defective overload protector. 9. Motor windings damaged. 10. Overcharged system. 11. Shortage of refrigerant. 12. Suction or discharge pressure too high. 13. Inadequate ventilation. 14. Operating system beyond design conditions.
Compressor short cycles.	<ol style="list-style-type: none"> 1. Low pressure control differential set too low. 2. Shortage of refrigerant. 3. Low airflow at evaporator(s). 4. Discharge pressure too high. 5. Compressor internal discharge valves leaking. 6. Incorrect unit selection (oversized). 7. Check Compressor Time Delay Setting (3-Minutes recommended)
Start relay burns out.	<ol style="list-style-type: none"> 1. Improperly wired. 2. Low or high line voltage. 3. Short cycling. 4. Improper mounting of relay. 5. Incorrect start or run capacitor. 6. Incorrect relay.
Contact welded stuck on start relay	<ol style="list-style-type: none"> 1. Short cycling. 2. No bleed resistor on start capacitor.
Start capacitor burns out	<ol style="list-style-type: none"> 1. Improperly wired. 2. Short cycling. 3. Low line voltage. 4. Relay contacts sticking. 5. Incorrect capacitor. 6. Start winding remaining in circuit for prolonged period.

SYSTEM TROUBLESHOOTING (cont'd)

System Troubleshooting Guide Continued	
Condensing Unit Problem	Possible Causes
Compressor noisy or vibrating.	<ol style="list-style-type: none"> 1. Flood back of refrigerant. 2. Improper piping support on the suction or discharge lines. 3. Broken or worn internal compressor parts. 4. Incorrect oil level. 5. Scroll compressor rotating in reverse (three phase). 6. Improper mounting on unit base.
Discharge pressure too high.	<ol style="list-style-type: none"> 1. Non-condensables in the system. 2. System overcharged with refrigerant. 3. Discharge service valve partially closed. 4. Condenser fan not running. 5. Dirty condenser coil.(air-cooled condensers) 6. Dirty tubes. .(water-cooled condensers) 7. Defective or improperly set water regulating valve. (water-cooled condensers) 8. Defective or improperly set flooded head pressure control.
Discharge pressure too low.	<ol style="list-style-type: none"> 1. Low suction pressure. 2. Cold ambient air. 3. Suction service valve partially closed. 4. Shortage of refrigerant. 5. Defective or improperly set water regulating valve. (water-cooled condensers) 6. Defective or improperly set flooded head pressure control.
Suction pressure too high.	<ol style="list-style-type: none"> 1. Excessive load. 2. Compressor internal valves broken. 3. Incorrect unit selection (undersized). 4. Improper TXV bulb charge.
Suction pressure too low.	<ol style="list-style-type: none"> 1. Shortage of refrigerant. 2. Evaporator dirty or iced up. 3. Clogged liquid line filter drier. 4. Clogged suction line filter or compressor suction strainers. 5. Expansion valve malfunctioning. 6. Condensing temperature too low. 7. Improper TX valve selection. 8. Evaporator distributor feed problems.
Low or no oil pressure.	<ol style="list-style-type: none"> 1. Low oil level. (trapped oil in evaporator or suction line) 2. Clogged suction oil strainer. 3. Excessive liquid refrigerant in the crankcase. 4. Worn oil pump. 5. Oil pump reversing gear sticking in the wrong position. 6. Worn bearings. 7. Loose fitting on oil line. 8. Pump housing gasket leaking.
Compressor loses oil.	<ol style="list-style-type: none"> 1. Refrigerant leak. 2. Short cycling. 3. Excessive compressor ring blowby. 4. Refrigerant flood back. 5. Improper piping or traps. 6. Trapped oil in evaporator.
Compressor runs continuously	<ol style="list-style-type: none"> 1. Excessive load. 2. Too low of a system thermostat setting or defective thermostat. 3. Shortage of refrigerant. 4. Leaking compressor internal valves. 5. Malfunctioning liquid line solenoid. 6. Incorrect unit selection (undersized).

SYSTEM TROUBLESHOOTING (cont'd)

System Troubleshooting Guide Continued	
Condensing Unit Problem	Possible Causes
Room temperature too high.	<ol style="list-style-type: none"> 1. Defective room thermostat or improper differential / setting. 2. Malfunctioning liquid line solenoid valve. 3. Insufficient air across evaporator coil (iced up coil, product blocking evaporator, fan blade / motor problem). 4. Improper evaporator superheat (low refrigerant charge, plugged TXV strainer, poor TXV bulb contact, incorrect TXV setting). 5. Malfunctioning condensing unit.
Room temperature too low.	<ol style="list-style-type: none"> 1. Defective room thermostat or improper differential / setting. 2. Malfunctioning liquid line solenoid valve.
Ice accumulating on ceiling.	<ol style="list-style-type: none"> 1. Defrost on too long (improper setting / defective termination thermostat, improper setting / defective time clock). 2. Too many defrosts per day. 3. Fans not delayed after defrost (improper setting / defective fan delay thermostat).
Evaporator coil not clear of ice after defrost.	<ol style="list-style-type: none"> 1. Defrost on too short (improper setting / defective termination thermostat, improper setting / defective time clock). 2. Electric heaters defective / miswired / low voltage. 3. Not enough defrosts per day. 4. Air defrost evaporator operating at too low of temperature (require electric defrost). 5. Defective / miswired interlock at compressor contactor. 6. Defective defrost contactor or coil.
Ice building up in drain pan.	<ol style="list-style-type: none"> 1. Improper slope in pan. 2. Blocked drain line (unheated , not insulated). 3. Electric heater in drain pan defective / miswired / low voltage). 4. Not enough defrosts per day. 5. Lack of or improper P-trap in drain line.
Evaporator fans will not operate.	<ol style="list-style-type: none"> 1. Main power switch open. 2. Fuse blown or tripped circuit breaker. 3. Defective contactor or coil. 4. Room temperature too high (fan delay thermostat open). 5. Fan delay thermostat improper setting / defective. 6. Defective fan motor (low voltage / tripped on thermal overload). 7. Defective time clock. 8. Normal mode during defrost cycle (electric defrost type evaporator).

IMPORTANT TROUBLESHOOTING NOTE

Before any components are changed on the refrigeration system, the cause of the failure must be identified. Further problems will exist unless the true cause or problem is identified and corrected.

CUSTOMER INSTRUCTIONS

Completely fill in System Start-Up Worksheets located in Appendix C at the back of this Installation and Maintenance Manual. This document should be left with the equipment for future reference.

Give the owner / end user instructions on normal operation of the system. Explain electrical characteristics, location of disconnect switches as well as other safety precautions. Advise on keeping equipment area clean and free of debris. If system has operational features, point these out to the operator.

MAINTENANCE PROGRAM

In order to ensure that the refrigeration system runs trouble free for many years, a follow-up maintenance program (consisting of a minimum of two inspections per year) should be set up. A qualified refrigeration service mechanic should carry out this semi-annual inspection. The main power supply must be disconnected and locked off to avoid accidental start up of the equipment.

- (1) Check electrical components and tighten any loose connections.
- (2) Check all wiring and electrical insulators.
- (3) Check contactors to ensure proper operation and contact point for wear.
- (4) Check that fan motors (if applicable) are operational, ensure fan blades are tight and all mounting bolts are tight.
- (5) Check oil and refrigerant levels in the system.
- (6) Ensure that the condenser surface (if applicable) is cleaned and free of dirt and debris.
- (7) Check the operation of the control system. Make certain that all of the safety controls are operational and functioning properly.
- (8) Check all refrigeration piping. Make sure that all mechanical joints and flare nuts are tight.

SERVICE PARTS AVAILABILITY

Genuine replacement service parts should be used whenever possible. Refer to the Service Parts List on the back cover of this Installation and Maintenance Manual or attached to the unit. Parts may be obtained by contacting your local sales representative or authorized distributor.

NOTES

Appendix A:

Wiring Diagrams

Wiring Diagram Cross Reference

Condensing Unit Voltage	Condensing Unit Type	Diagram Number	Page	Evaporator Voltage and Type	Diagram Number	Page
COPELAND SCROLL						
208-230/1/60	Small Scroll	S2A1D	A2	230 Air Defrost Low Profile	KA101	A13
208-230/3/60	Small Scroll	T3A1A	A3	230 Electric Defrost Low Profile	LPE101	A14
208-230/3/60	Small Scroll+ Coresense	T3A1D	A5	2x 230 Electric Defrost Low Profile	LPE201	A15
208-230/3/60	Large Scroll+ Coresense	T3C6A	A6	2x 230 Electric Defrost Med Profile	JE101A	A16
460/3/60	Small Scroll+ Coresense	T4A6A	A9	460 Electric Defrost Med Profile	JE101A	A16
460/3/60	Large Scroll+ Coresense	T4C6A	A10	2x 460 Electric Defrost Med Profile	JE201A	A17
COPELAND HERMETIC						
208-230/1/60		S2A1A	A1	230 Air Defrost Low Profile	KA101	A13
208-230/3/60		T3A1A	A3	230 Electric Defrost Low Profile	LPE101	A14
460/3/60 & 575/3/60		T4A1A	A8	2x 230 Electric Defrost Low Profile	JE101A	A16
SEMI-HERMETIC						
208-230/1/60	Copelametic	S2A1A	A1	230 Air Defrost Low Profile	KA101	A13
208-230/3/60	Bitzer	T3B1A	A4	230 Electric Defrost Low Profile	LPE101	A14
208-230/3/60	Discus	T3L1A	A7	2x 230 Electric Defrost Low Profile	LPE201	A15
460/3/60 & 575/3/60	Discus	T4L1A	A12	460 Electric Defrost Med Profile	JE101A	A16
460/3/60 & 575/3/60	Discus Demand Cooling	T4A4A	A11	2x 460 Electric Defrost Med Profile	JE201A	A17

Condensing Unit Wiring Diagram – S2A1A

CONDENSING UNIT WIRING DIAGRAM

- 208/230V-1-60 or 200/220V-1-50 Hz
- OPTIONAL CORESENSE OIL PROTECTION
- STANDARD CONTROL CIRCUIT

REFER TO CONDENSING UNIT NAMEPLATE FOR ELECTRICAL REQUIREMENTS

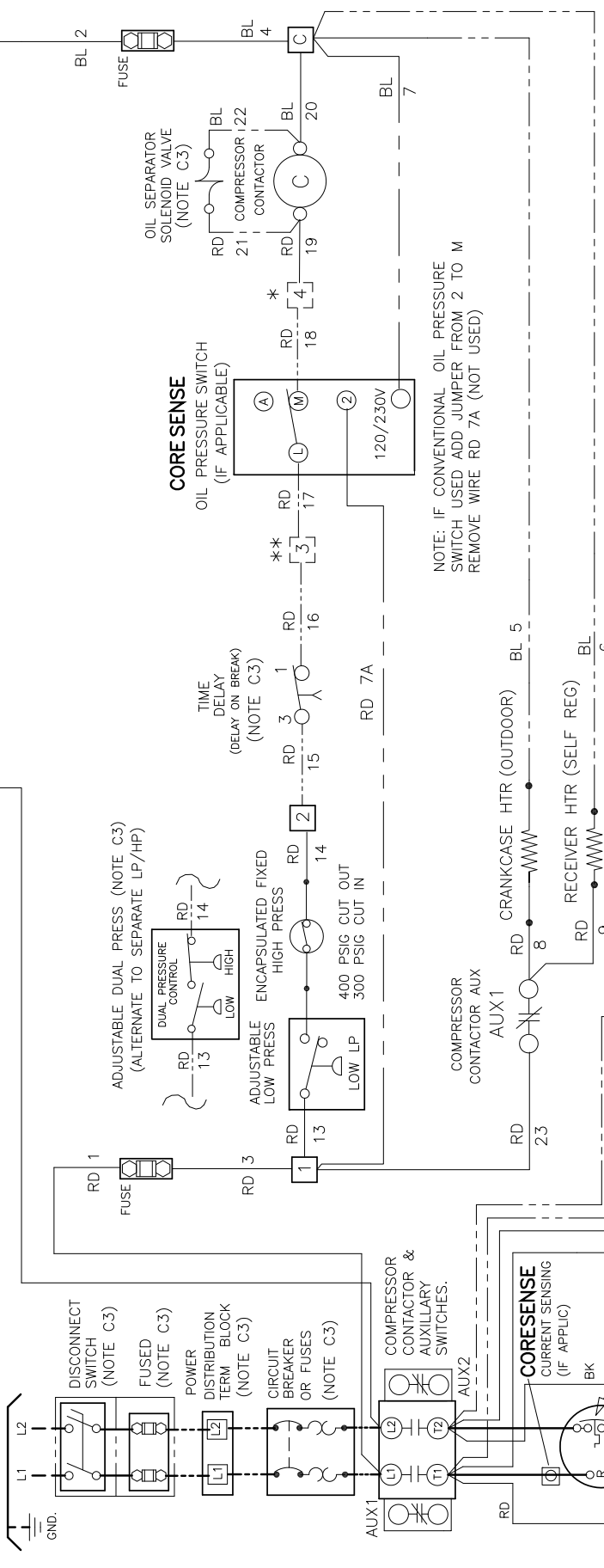

CORESENSE

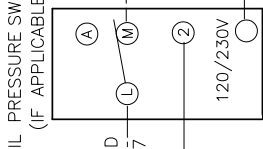

NOTE: IF CONVENTIONAL OIL PRESSURE SWITCH USED ADD JUMPER FROM 2 TO M REMOVE WIRE RD 7A (NOT USED)

NOTES

- C1. USE COPPER CONDUCTORS ONLY
- C2. USE 75°C WIRE (OR HIGHER)
- C3. OPTIONAL COMPONENT
- C4. ALL FUSES TO BE CLASS CC OR J AND VOLTAGE RATED EQUAL (OR HIGHER) THAN OPERATING VOLTAGE

CONDUCTORS/WIRING

- FACTORY WIRING
 - - - OPTIONAL WIRING
 - WIRING BY OTHERS
- ALL FIELD WIRING MUST BE DONE IN COMPLIANCE WITH ALL APPLICABLE LOCAL AND NATIONAL CODES.

- * IF OIL SWITCH NOT REQUIRED, WIRE RD19 TO TERMINAL 3
- ** IF TIMER NOT USED, WIRE RD17 TO TERMINAL 2
- IF OIL SWITCH AND TIME DELAY NOT REQUIRED, WIRE RD19 TO TERMINAL 2

REVISIONS	DATE	LTR	DIAGRAM NUMBER
H	NOV1/17		S2A1A
G	JULY18/12		
F	MAY31/11		
E	NOV 30/10		
D	JAN 9/09		

CONDENSER FAN #1
CONDENSER FAN #2 (RIGHT H. SIDE-IF APPLICABLE)

CONDENSER FAN #1
CONDENSER FAN #2

NOTE: ABOVE TYPICAL WIRING SHOWN WITH START COMPONENTS IN MAIN CONTROL PANEL REFER TO COMPRESSOR TERM BOX FOR SPECIFIC DIAGRAM

Condensing Unit Wiring Diagram – S2A1D

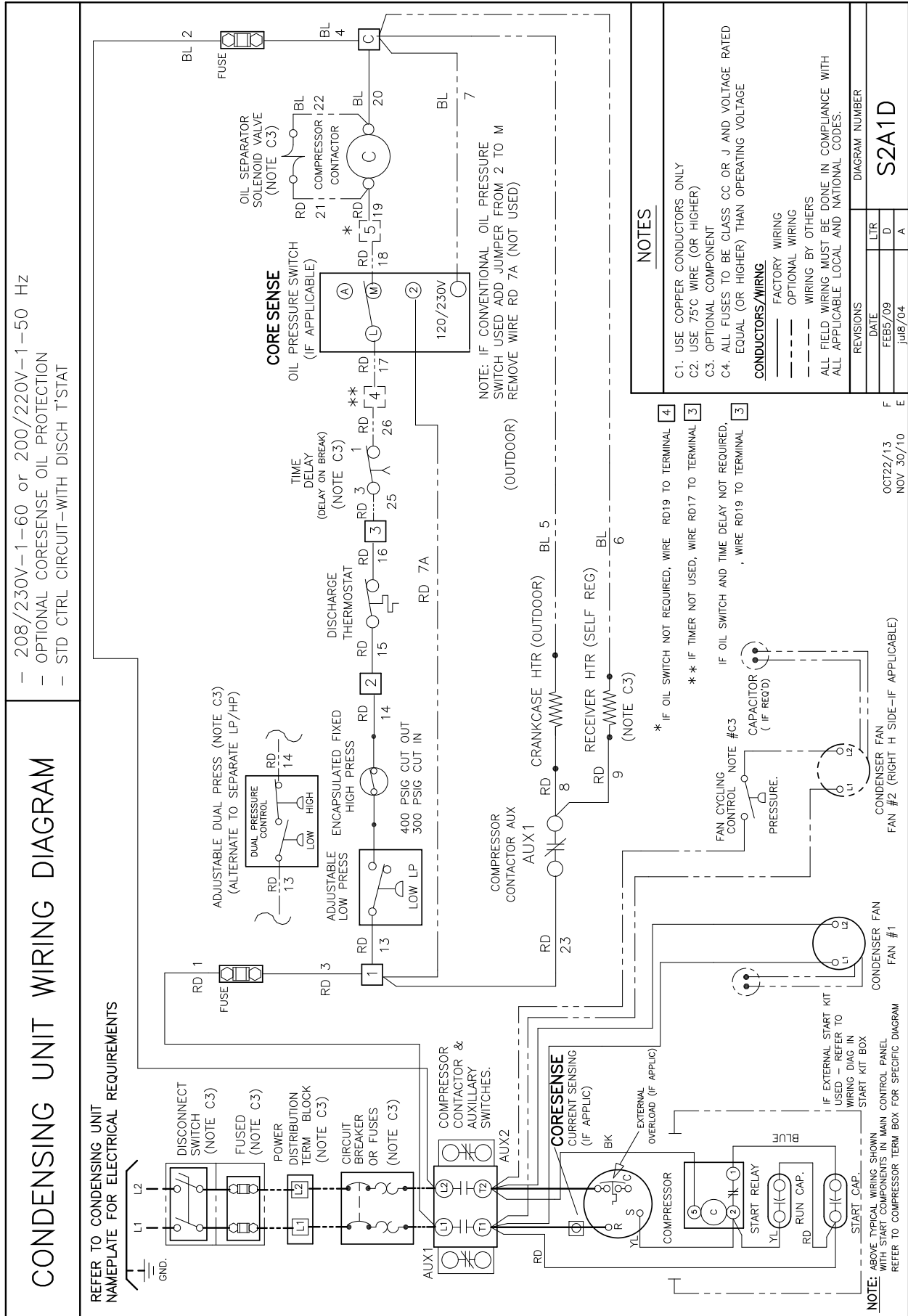

Condensing Unit Wiring Diagram – T3A1A

CONDENSING UNIT WIRING DIAGRAM

- 208/230V-3-60 or 200/220V-3-50 Hz
- INHERENT MOTOR OVERLOAD WITH OPTIONAL CORESENSE OIL PROTECTION
- STANDARD CONTROL CIRCUIT

REFER TO CONDENSING UNIT NAMEPLATE FOR ELECTRICAL REQUIREMENTS.

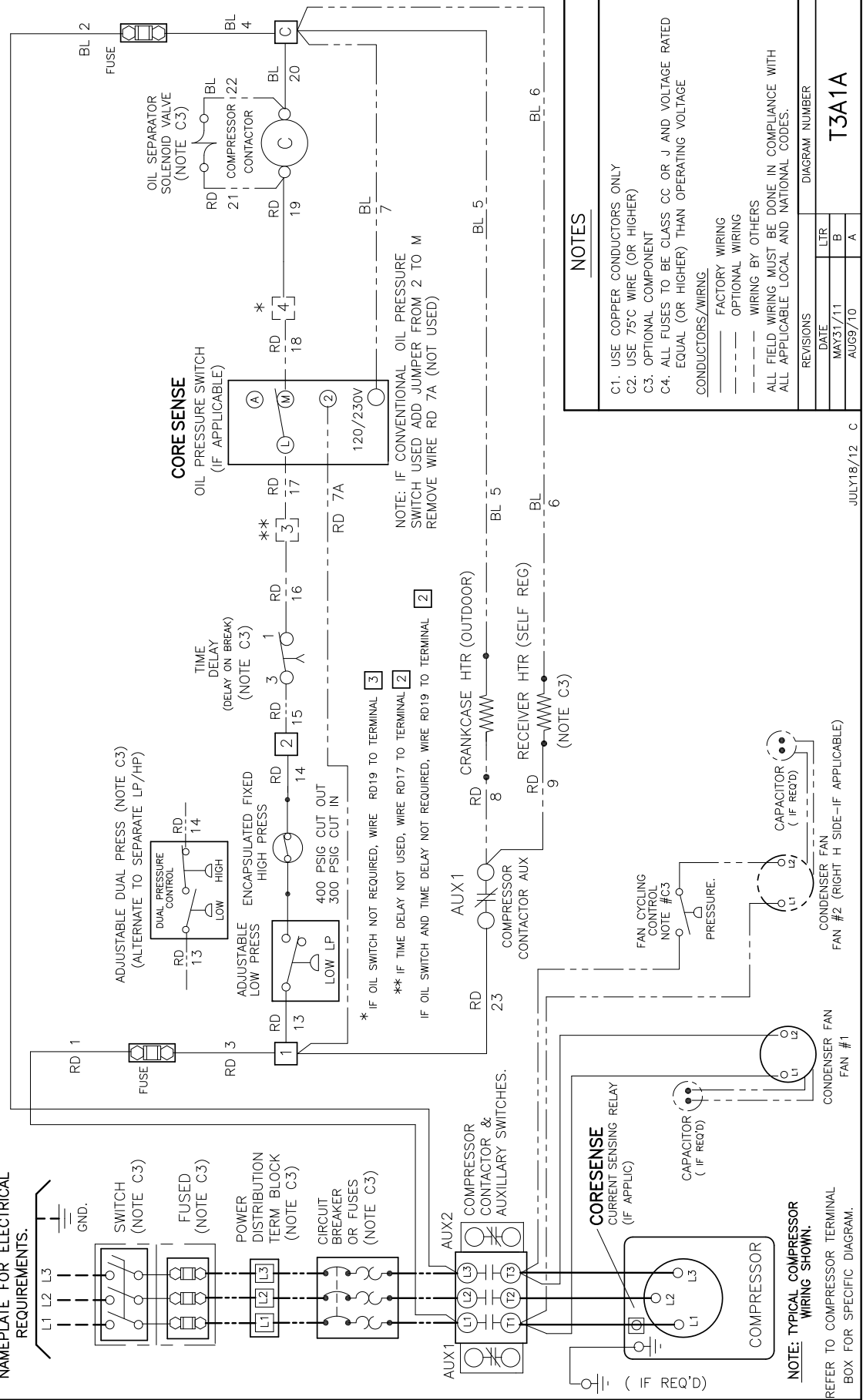

NOTE: TYPICAL COMPRESSOR WIRING SHOWN.
REFER TO COMPRESSOR TERMINAL BOX FOR SPECIFIC DIAGRAM.

NOTES

- C1. USE COPPER CONDUCTORS ONLY
 - C2. USE 75°C WIRE (OR HIGHER)
 - C3. OPTIONAL COMPONENT
 - C4. ALL FUSES TO BE CLASS CC OR J AND VOLTAGE RATED EQUAL (OR HIGHER) THAN OPERATING VOLTAGE
- CONDUCTORS/WIRING
 - - - - - FACTORY WIRING
 - - - - - OPTIONAL WIRING
 - - - - - WIRING BY OTHERS
- ALL FIELD WIRING MUST BE DONE IN COMPLIANCE WITH ALL APPLICABLE LOCAL AND NATIONAL CODES.

REVISIONS		DIAGRAM NUMBER	
DATE	LTR	T3A1A	
MAY31/11	B		
AUG9/10	A		

JULY18/12 C

Condensing Unit Wiring Diagram – T3B1A (Bitzer)

CONDENSING UNIT WIRING DIAGRAM

- 208/230V-3-60 or 200/220V-3-50 Hz
- SOLID STATE MODULE MOTOR PROTECTION (BITZER OCTAGON)
- STANDARD CONTROL CIRCUIT

REFER TO CONDENSING UNIT NAMEPLATE FOR ELECTRICAL REQUIREMENTS.

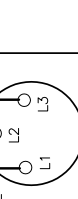
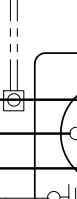
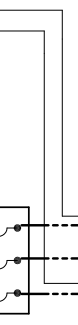
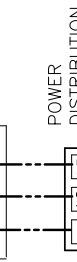
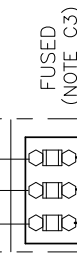
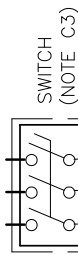
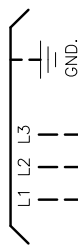

NOTES

- C1. USE COPPER CONDUCTORS ONLY
- C2. USE 75°C WIRE (OR HIGHER)
- C3. OPTIONAL COMPONENT
- C4. ALL FUSES TO BE CLASS CC OR J AND VOLTAGE RATED EQUAL (OR HIGHER) THAN OPERATING VOLTAGE

CONDUCTORS/WIRING

- FACTORY WIRING
- - - OPTIONAL WIRING
- WIRING BY OTHERS

ALL FIELD WIRING MUST BE DONE IN COMPLIANCE WITH ALL APPLICABLE LOCAL AND NATIONAL CODES.

REVISIONS

DATE	LTR	DIAGRAM NUMBER
FEB05/09	D	T3B1A
Jul 23/03	A	

DATE	LTR	DIAGRAM NUMBER
NOV1/17	F	T3B1A
NOV22/10	E	

- * IF OIL SWITCH NOT REQUIRED, WIRE RD19 TO TERMINAL 4
- ** IF TIME DELAY NOT USED, WIRE RD17 TO TERMINAL 3
- IF OIL SWITCH AND TIME DELAY NOT REQUIRED, WIRE RD19 TO TERMINAL 3

BITZER MODULE TO ENABLE MANUAL RE-SET FUNCTION, ADD JUMPER BETWEEN B1 AND B2. TO RE-SET ANY MANUAL LOCK-OUT, REMOVE CONTROL CIRC POWER MOMENTARILY (ON-OFF-ON)

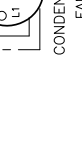
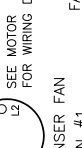
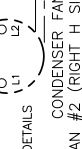

Condensing Unit Wiring Diagram – T3A1D

CONDENSING UNIT WIRING DIAGRAM

- 208/230V-3-60 or 200/220V-3-50 Hz
- INHERENT LINE BREAK MOTOR PROTECTION
- STANDARD CONTROL CIRCUIT-WITH DISCHARGE T'STAT

REFER TO CONDENSING UNIT NAMEPLATE FOR ELECTRICAL REQUIREMENTS.

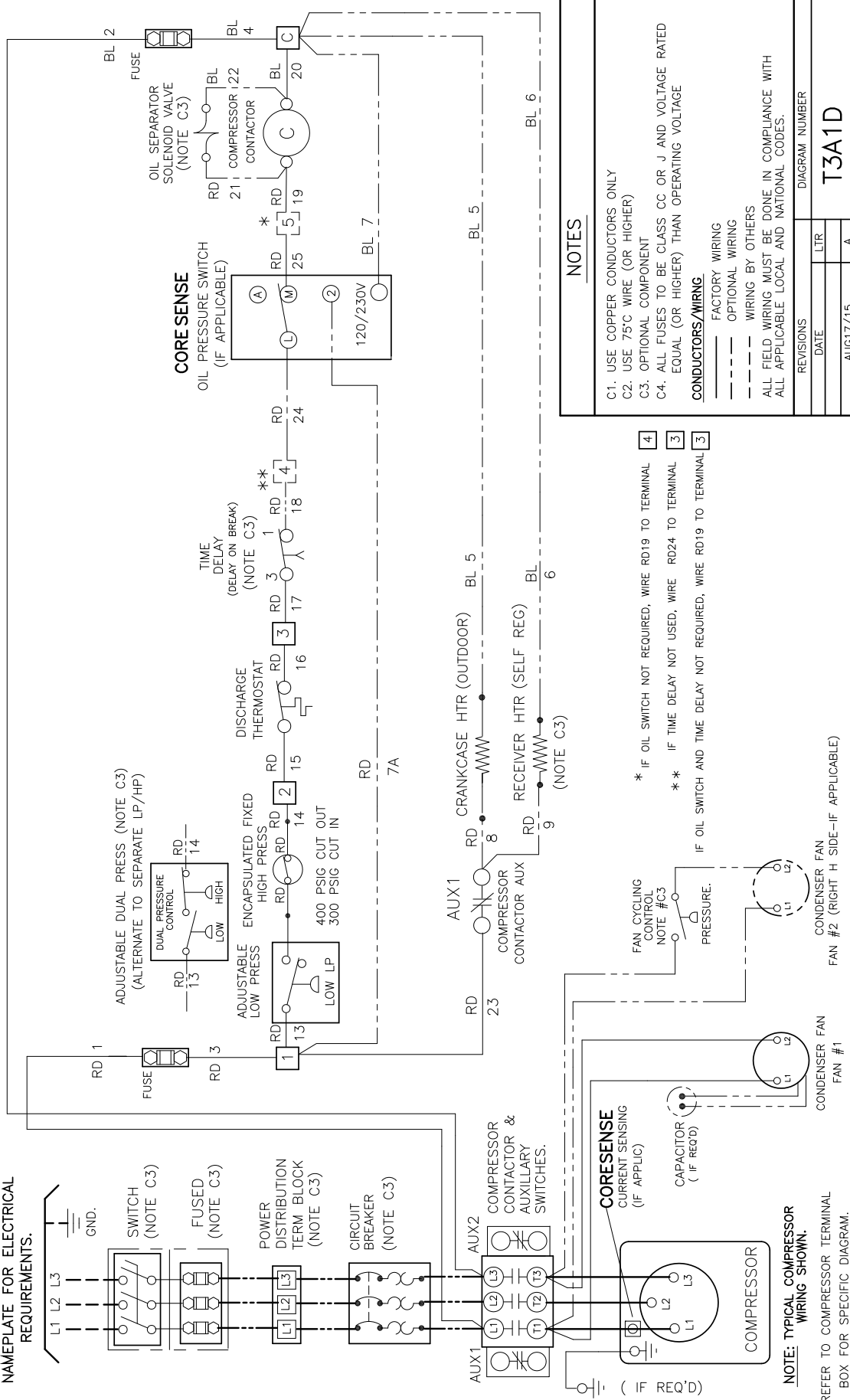

NOTES

- C1. USE COPPER CONDUCTORS ONLY
- C2. USE 75°C WIRE (OR HIGHER)
- C3. OPTIONAL COMPONENT
- C4. ALL FUSES TO BE CLASS CC OR J AND VOLTAGE RATED EQUAL (OR HIGHER) THAN OPERATING VOLTAGE

CONDUCTORS/WIRING

- FACTORY WIRING
- - - OPTIONAL WIRING
- - - WIRING BY OTHERS
- - - ALL FIELD WIRING MUST BE DONE IN COMPLIANCE WITH ALL APPLICABLE LOCAL AND NATIONAL CODES.

- * IF OIL SWITCH NOT REQUIRED, WIRE RD19 TO TERMINAL 4
- ** IF TIME DELAY NOT USED, WIRE RD24 TO TERMINAL 3
- IF OIL SWITCH AND TIME DELAY NOT REQUIRED, WIRE RD19 TO TERMINAL 3

NOTE: TYPICAL COMPRESSOR WIRING SHOWN.

REFER TO COMPRESSOR TERMINAL BOX FOR SPECIFIC DIAGRAM.

REVISIONS		DIAGRAM NUMBER	
DATE	LTR	T3A1D	
AUG17/15	A		

Condensing Unit Wiring Diagram – T3C6A

CONDENSING UNIT WIRING DIAGRAM

- 208/230V-3-60 or 200/220V-3-50 Hz
- SCROLL 260 B/M SS MOTOR PROT MODULE AND CORESENSE MODULE
- STANDARD CONTROL CIRCUIT

REFER TO CONDENSING UNIT NAMEPLATE FOR ELECTRICAL REQUIREMENTS.

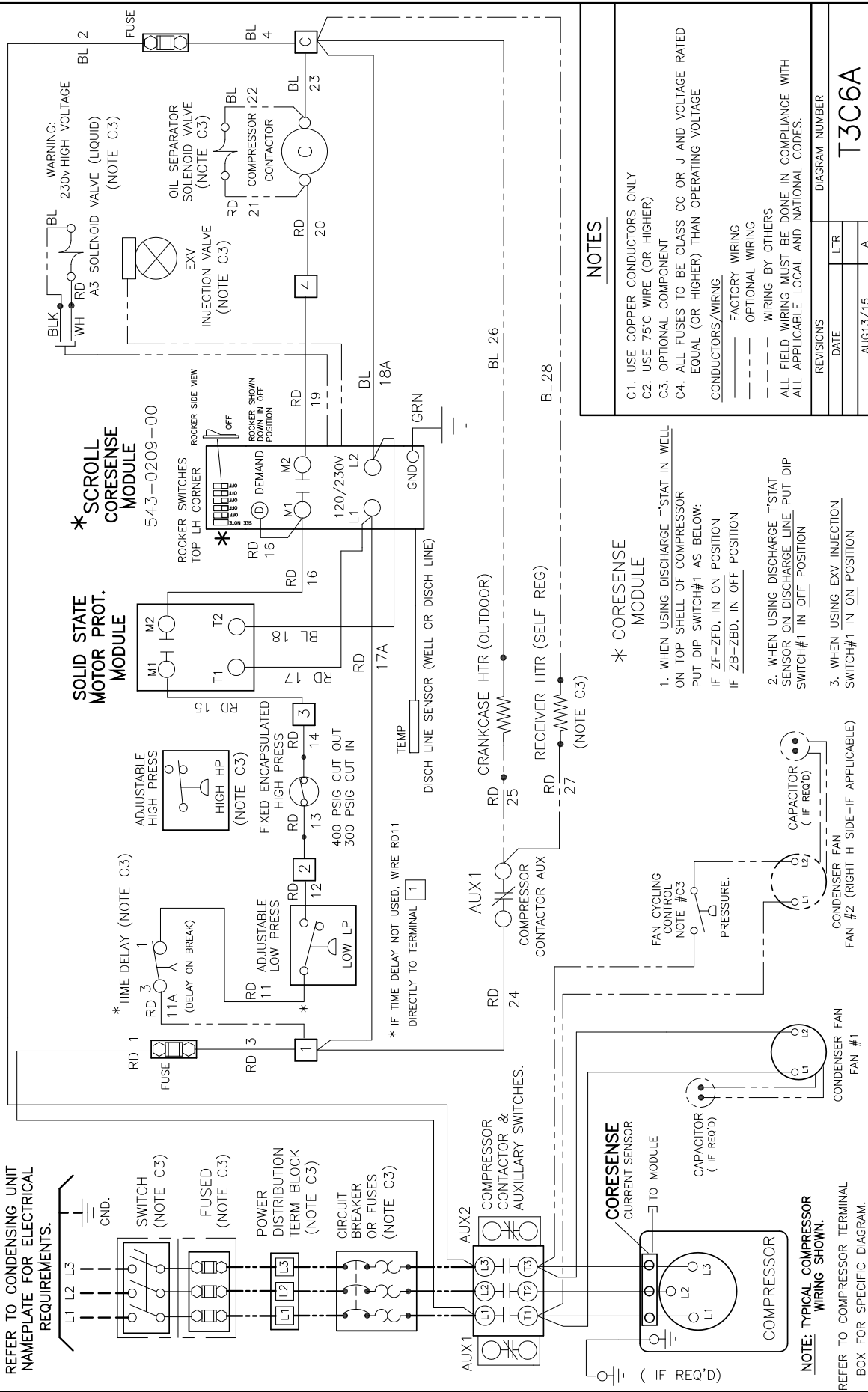

- 208/230V-3-60 or 200/220V-3-50 Hz
- SCROLL 260 B/M SS MOTOR PROT MODULE AND CORESENSE MODULE
- STANDARD CONTROL CIRCUIT

REFER TO CONDENSING UNIT NAMEPLATE FOR ELECTRICAL REQUIREMENTS.

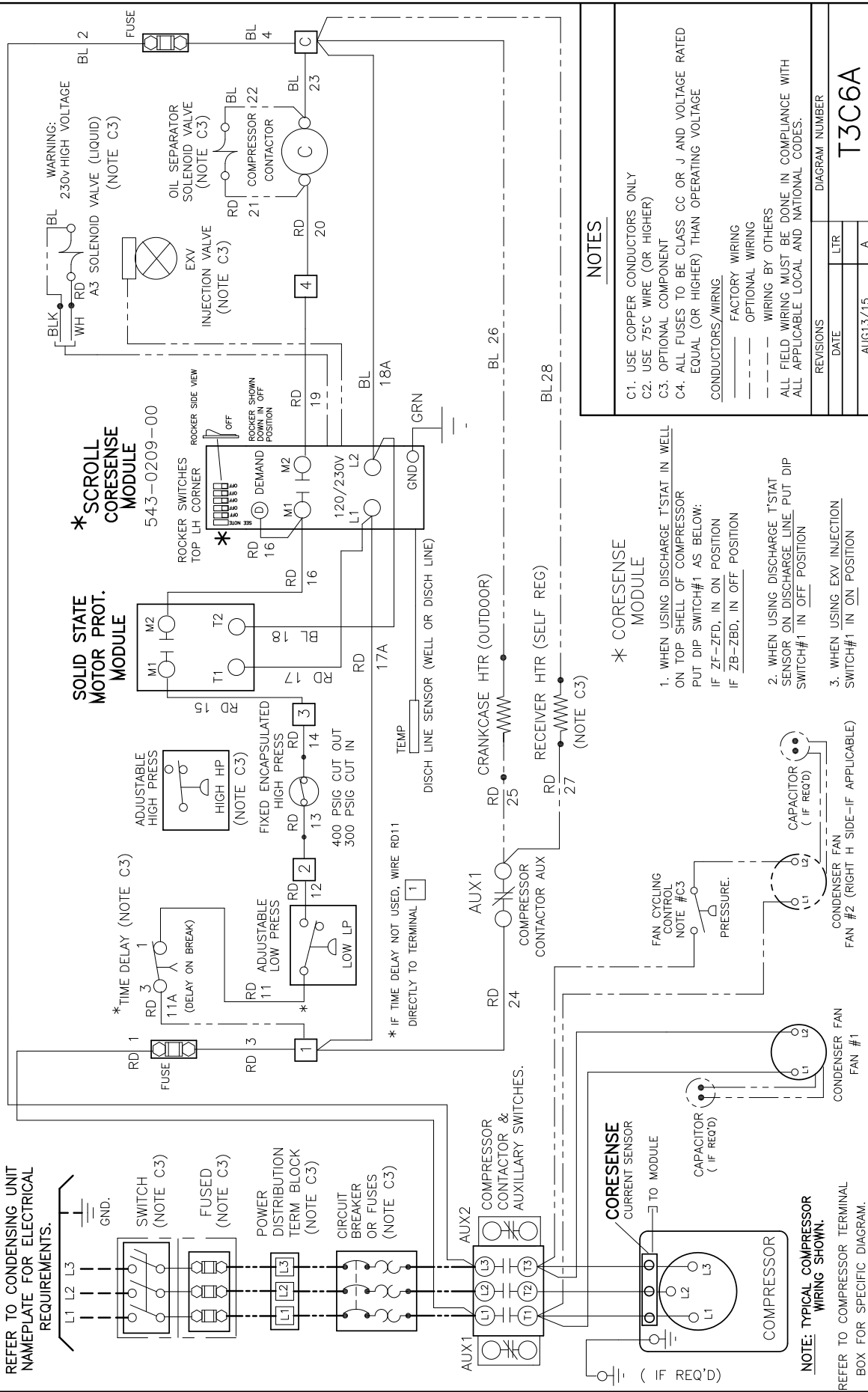

- NOTES**
- C1. USE COPPER CONDUCTORS ONLY
 - C2. USE 75°C WIRE (OR HIGHER)
 - C3. OPTIONAL COMPONENT
 - C4. ALL FUSES TO BE CLASS CC OR J AND VOLTAGE RATED EQUAL (OR HIGHER) THAN OPERATING VOLTAGE
- CONDUCTORS/WIRING
- FACTORY WIRING
 - - - OPTIONAL WIRING
 - WIRING BY OTHERS
- ALL FIELD WIRING MUST BE DONE IN COMPLIANCE WITH ALL APPLICABLE LOCAL AND NATIONAL CODES.

- * CORESENSE MODULE**
1. WHEN USING DISCHARGE T'STAT IN WELL ON TOP SHELL OF COMPRESSOR PUT DIP SWITCH#1 AS BELOW:
IF ZF-ZFD, IN ON POSITION
IF ZB-ZBD, IN OFF POSITION
 2. WHEN USING DISCHARGE T'STAT SENSOR ON DISCHARGE LINE PUT DIP SWITCH#1 IN OFF POSITION
 3. WHEN USING EXV INJECTION SWITCH#1 IN ON POSITION

- * SCROLL CORESENSE MODULE**
543-0209-00
- SOLID STATE MOTOR PROT. MODULE**
- ROCKER SWITCHES TOP LH CORNER
- ROCKER SIDE VIEW
- ROCKER SHOWN DOWN IN OFF POSITION
- WARNING: 230v HIGH VOLTAGE
- A3 SOLENOID VALVE (LIQUID) (NOTE C3)
- INJECTION VALVE EXV (NOTE C3)
- OIL SEPARATOR SOLENOID VALVE (NOTE C3)
- 21, COMPRESSOR CONTACTOR
- RD 19, RD 20, RD 23, RD 25, RD 27
- BL 2, BL 4, BL 18A, BL 26, BL 28
- FUSE
- ADJUSTABLE HIGH PRESS HIGH HP (NOTE C3)
- FIXED ENCAPSULATED HIGH PRESS 400 PSIG CUT OUT 300 PSIG CUT IN
- ADJUSTABLE LOW PRESS LOW LP
- * TIME DELAY (NOTE C3)
- RD 11A (DELAY ON BREAK)
- * IF TIME DELAY NOT USED, WIRE RD11 DIRECTLY TO TERMINAL 1
- TEMP DISCH LINE SENSOR (WELL OR DISCH LINE)
- CRANKCASE HTR (OUTDOOR)
- RECEIVER HTR (SELF REG)
- (NOTE C3)
- FAN CYCLING CONTROL NOTE #C3 PRESSURE.
- CAPACITOR (IF REQ'D)
- CONDENSER FAN FAN #2 (RIGHT H SIDE-IF APPLICABLE)
- CONDENSER FAN FAN #1
- COMPRESSOR & AUXILIARY SWITCHES.
- COMPRESSOR
- CAPACITOR (IF REQ'D)
- TO MODULE
- CAPACITOR (IF REQ'D)
- CONDENSER FAN FAN #1
- CONDENSER FAN FAN #2 (RIGHT H SIDE-IF APPLICABLE)

NOTE: TYPICAL COMPRESSOR WIRING SHOWN.
REFER TO COMPRESSOR TERMINAL BOX FOR SPECIFIC DIAGRAM.

REVISIONS		DIAGRAM NUMBER
DATE	LTR	T3C6A
AUG13/15	A	

Condensing Unit Wiring Diagram – T3L1A

- 208/230V-3-60 or 200/220V-3-50 Hz
- CORESENSE MOTOR AND OIL PROTECTION
- STANDARD CONTROL CIRCUIT

CONDENSING UNIT WIRING DIAGRAM

REFER TO CONDENSING UNIT NAMEPLATE FOR ELECTRICAL REQUIREMENTS.

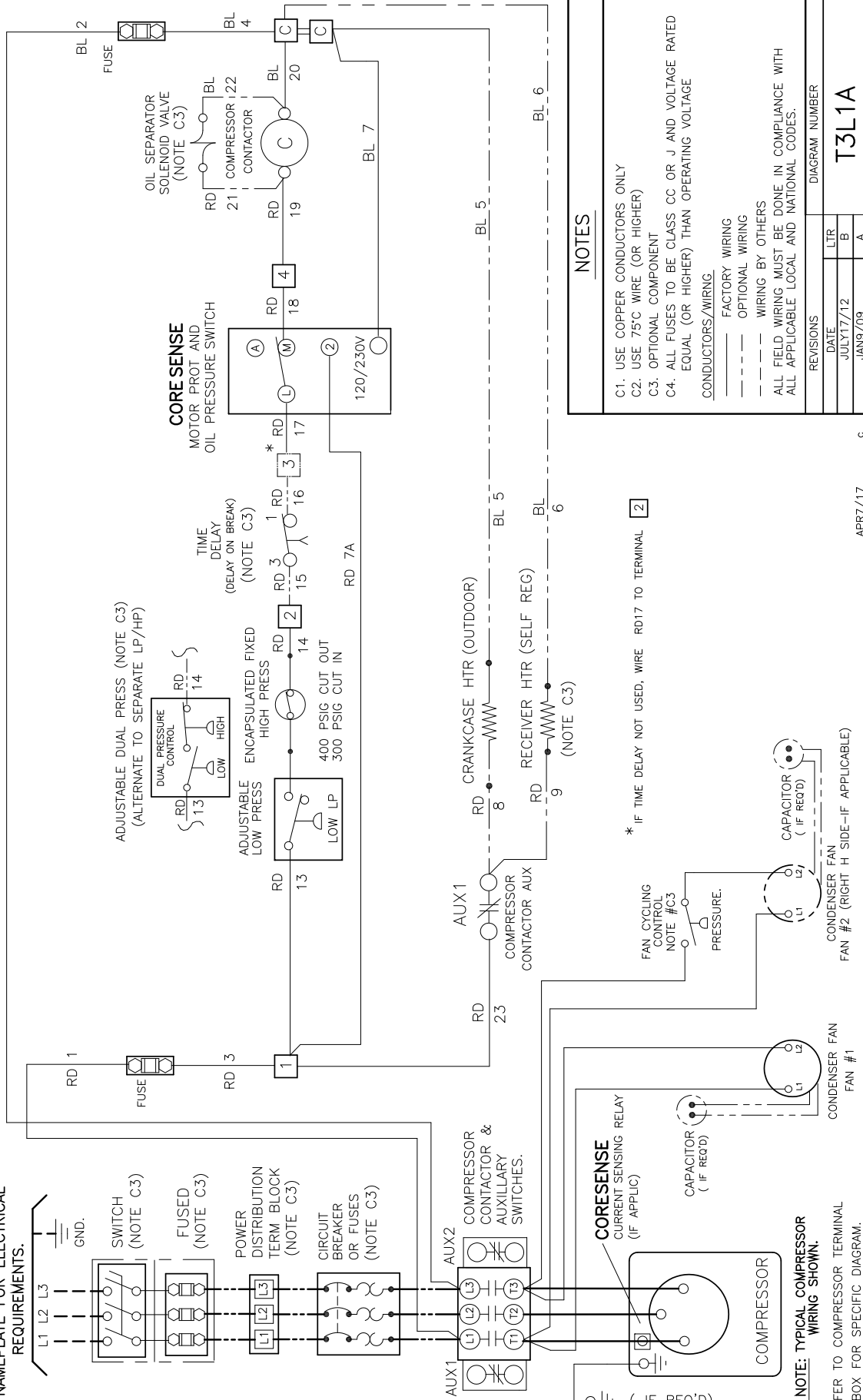

NOTES

- C1. USE COPPER CONDUCTORS ONLY
 - C2. USE 75°C WIRE (OR HIGHER)
 - C3. OPTIONAL COMPONENT
 - C4. ALL FUSES TO BE CLASS CC OR J AND VOLTAGE RATED EQUAL (OR HIGHER) THAN OPERATING VOLTAGE CONDUCTORS/WIRING.
- _____ FACTORY WIRING
 - - - - - OPTIONAL WIRING
 - - - - - WIRING BY OTHERS
- ALL FIELD WIRING MUST BE DONE IN COMPLIANCE WITH ALL APPLICABLE LOCAL AND NATIONAL CODES.

REVISIONS		DIAGRAM NUMBER	
DATE	LTR		
JULY17/12	B		
JAN9/03	A		

T3L1A

* IF TIME DELAY NOT USED, WIRE RD17 TO TERMINAL 2

NOTE: TYPICAL COMPRESSOR WIRING SHOWN.

REFER TO COMPRESSOR TERMINAL BOX FOR SPECIFIC DIAGRAM.

APR7/17 c

Condensing Unit Wiring Diagram – T4A1A

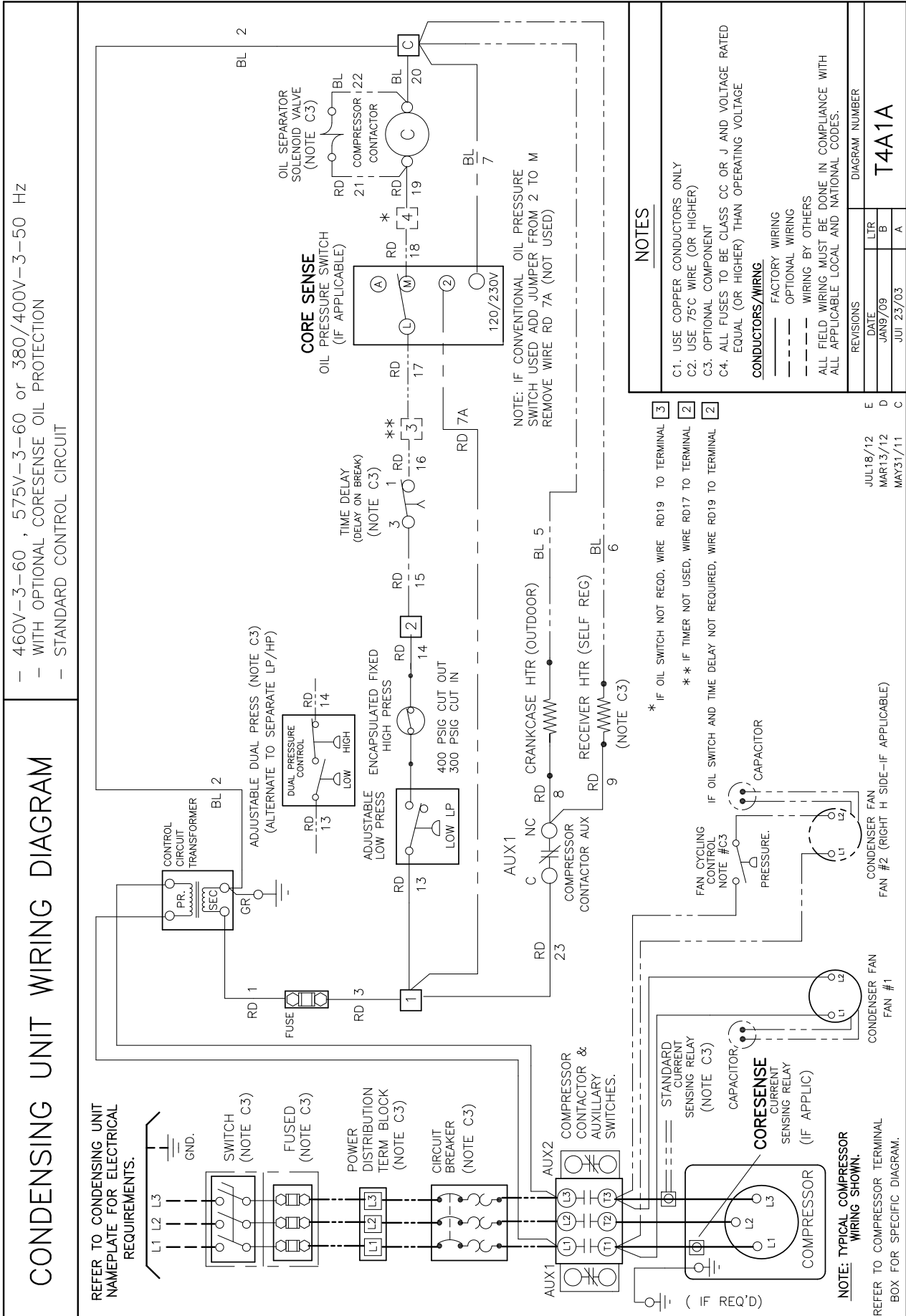

Condensing Unit Wiring Diagram – T4A6A

CONDENSING UNIT WIRING DIAGRAM

- 460V-3-60, 575V-3-60 or 380/400V-3-50 Hz
- INHERENT MOTOR OVERLOAD WITH SCROLL 260 BOM CORESENSE PROTECTION
- STANDARD CONTROL CIRCUIT

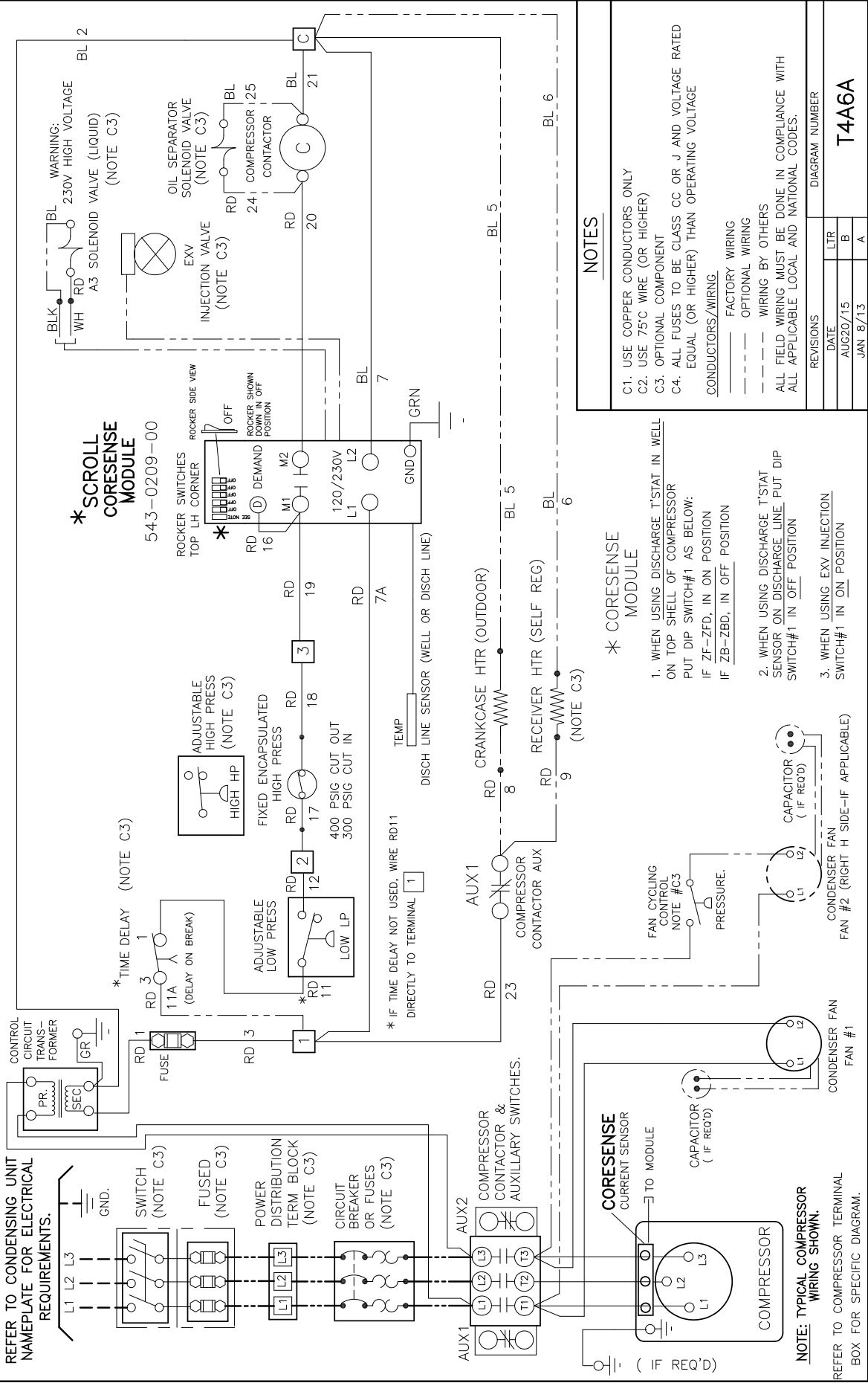

REFER TO CONDENSING UNIT NAMEPLATE FOR ELECTRICAL REQUIREMENTS.

NOTE: TYPICAL COMPRESSOR WIRING SHOWN. REFER TO COMPRESSOR TERMINAL BOX FOR SPECIFIC DIAGRAM.

NOTES

- C1. USE COPPER CONDUCTORS ONLY
 - C2. USE 75°C WIRE (OR HIGHER)
 - C3. OPTIONAL COMPONENT
 - C4. ALL FUSES TO BE CLASS CC OR J AND VOLTAGE RATED EQUAL (OR HIGHER) THAN OPERATING VOLTAGE
- CONDUCTORS/WIRING
- FACTORY WIRING
 - - - OPTIONAL WIRING
 - - - WIRING BY OTHERS
- ALL FIELD WIRING MUST BE DONE IN COMPLIANCE WITH ALL APPLICABLE LOCAL AND NATIONAL CODES.

* CORESENSE MODULE

- WHEN USING DISCHARGE T'STAT IN WELL ON TOP SHELL OF COMPRESSOR PUT DIP SWITCH#1 AS BELOW:
IF ZF-ZFD, IN ON POSITION
IF ZB-ZBD, IN OFF POSITION
- WHEN USING DISCHARGE T'STAT SENSOR ON DISCHARGE LINE PUT DIP SWITCH#1 IN OFF POSITION
- WHEN USING EXV INJECTION SWITCH#1 IN ON POSITION

REVISIONS		DIAGRAM NUMBER	
DATE	LTR	T4A6A	
AUG20/15	B		
JAN 8/13	A		

Condensing Unit Wiring Diagram – T4C6A

CONDENSING UNIT WIRING DIAGRAM

- 575V-3-60 Hz
- SCROLL 260 B/M SS MOTOR PROT MODULE AND CORESENSE MODULE
- STANDARD CONTROL CIRCUIT

REFER TO CONDENSING UNIT NAMEPLATE FOR ELECTRICAL REQUIREMENTS.

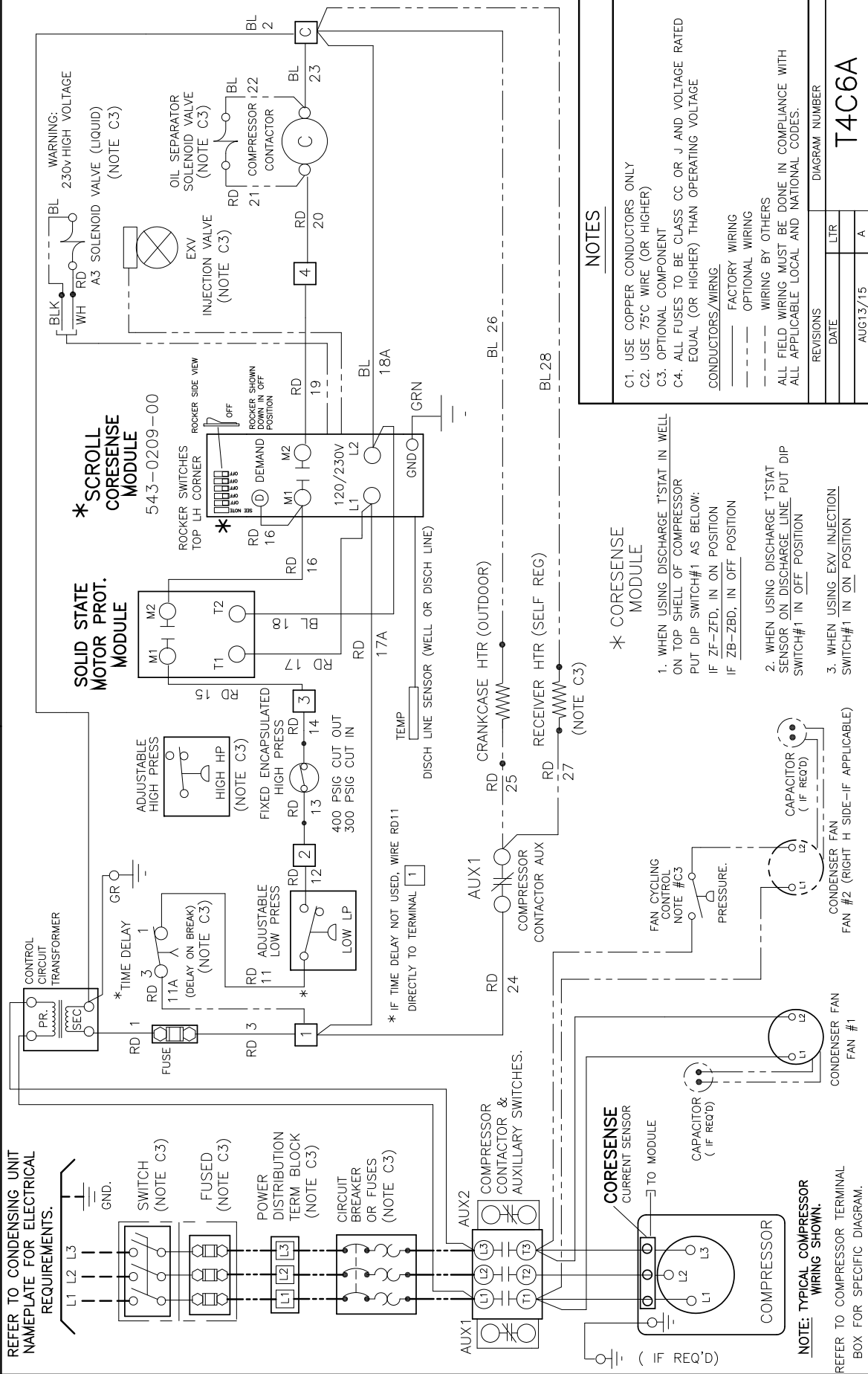

REFER TO CONDENSING UNIT NAMEPLATE FOR ELECTRICAL REQUIREMENTS.

NOTE: TYPICAL COMPRESSOR WIRING SHOWN.
REFER TO COMPRESSOR TERMINAL BOX FOR SPECIFIC DIAGRAM.

NOTES

- C1. USE COPPER CONDUCTORS ONLY
 - C2. USE 75°C WIRE (OR HIGHER)
 - C3. OPTIONAL COMPONENT
 - C4. ALL FUSES TO BE CLASS CC OR J AND VOLTAGE RATED EQUAL (OR HIGHER) THAN OPERATING VOLTAGE
- CONDUCTORS/WIRING
- FACTORY WIRING
 - - - OPTIONAL WIRING
 - WIRING BY OTHERS
- ALL FIELD WIRING MUST BE DONE IN COMPLIANCE WITH ALL APPLICABLE LOCAL AND NATIONAL CODES.

* CORESENSE MODULE

- WHEN USING DISCHARGE T'STAT IN WELL ON TOP SHELL OF COMPRESSOR PUT DIP SWITCH#1 AS BELOW:
IF ZF-ZED, IN ON POSITION
IF ZB-ZBD, IN OFF POSITION
- WHEN USING DISCHARGE T'STAT SENSOR ON DISCHARGE LINE PUT DIP SWITCH#1 IN OFF POSITION
- WHEN USING EXV INJECTION SWITCH#1 IN ON POSITION

REVISIONS		DIAGRAM NUMBER
DATE	LTR	T4C6A
	A	

Condensing Unit Wiring Diagram – T4A4A

CONDENSING UNIT WIRING DIAGRAM

- 460V-3-60, 575-3-60 or 380/400-3-50 Hz
- 2D-3D CORESENSE MOTOR AND OIL PROTECTION WITH DEMAND COOLING
- STANDARD 230V CONTROL CIRCUIT

REFER TO CONDENSING UNIT NAMEPLATE FOR ELECTRICAL REQUIREMENTS.

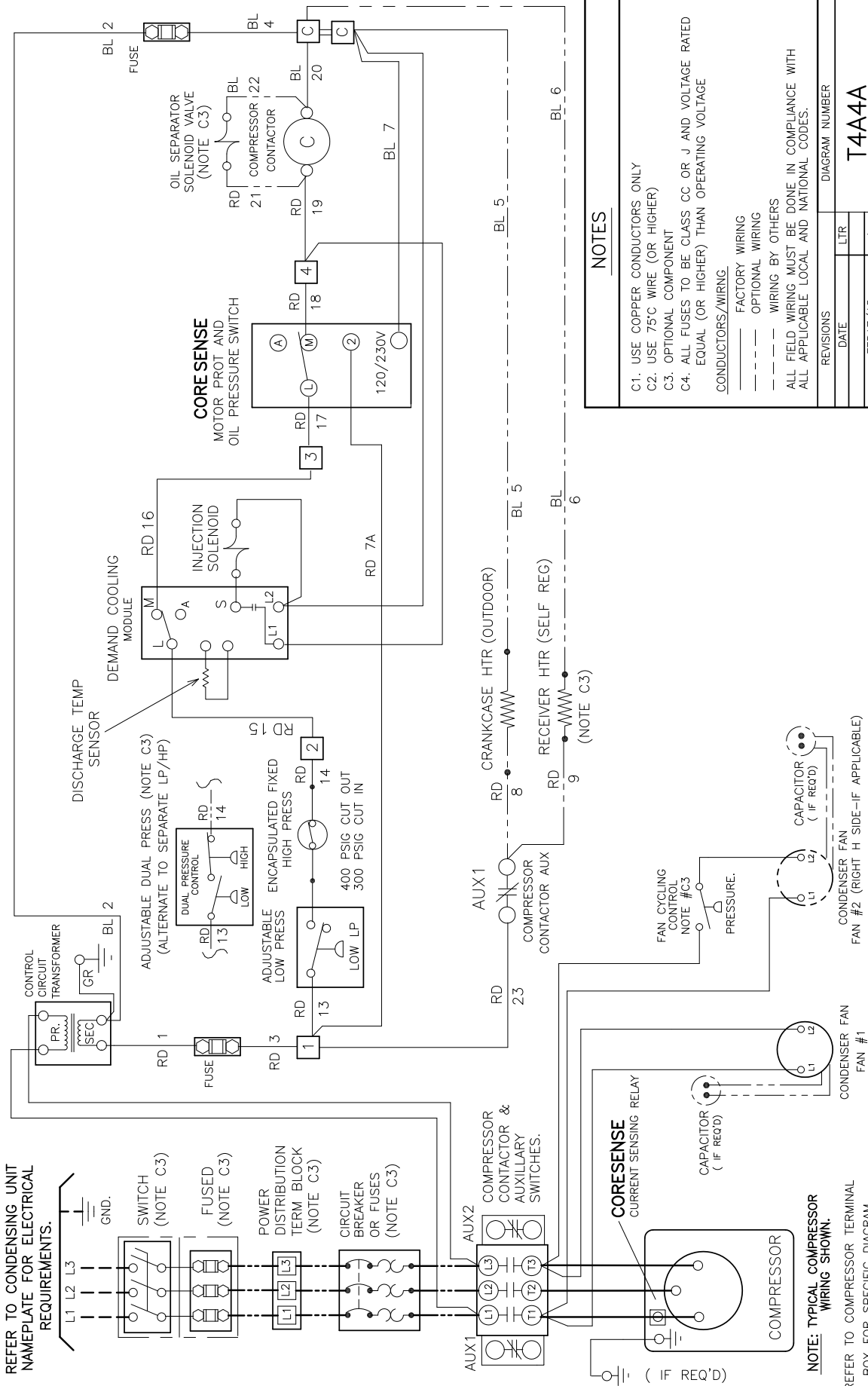

NOTE: TYPICAL COMPRESSOR WIRING SHOWN. REFER TO COMPRESSOR TERMINAL BOX FOR SPECIFIC DIAGRAM.

NOTES

- C1. USE COPPER CONDUCTORS ONLY
 - C2. USE 75°C WIRE (OR HIGHER)
 - C3. OPTIONAL COMPONENT
 - C4. ALL FUSES TO BE CLASS CC OR J AND VOLTAGE RATED EQUAL (OR HIGHER) THAN OPERATING VOLTAGE CONDUCTORS/WIRING
- FACTORY WIRING
 - - - - - OPTIONAL WIRING
 - - - - - WIRING BY OTHERS
 ALL FIELD WIRING MUST BE DONE IN COMPLIANCE WITH ALL APPLICABLE LOCAL AND NATIONAL CODES.

REVISIONS		DIAGRAM NUMBER	
DATE	LTR	T4A4A	
FEB17/15	A		

Condensing Unit Wiring Diagram – T4L1A

CONDENSING UNIT WIRING DIAGRAM

- 460V-3-60 , 575V-3-60 or 380/400V-3-50 Hz
- CORESENSE MOTOR AND OIL PROTECTION
- STANDARD CONTROL CIRCUIT

REFER TO CONDENSING UNIT NAMEPLATE FOR ELECTRICAL REQUIREMENTS.

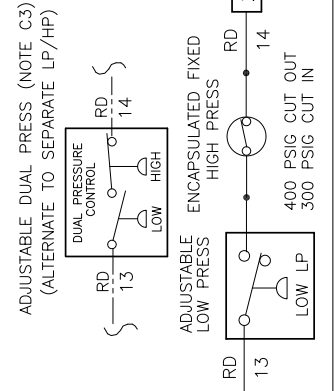
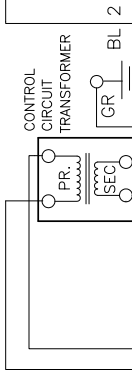
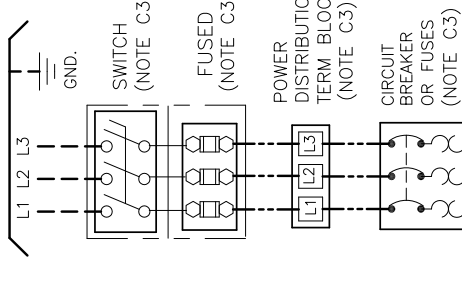

** NOTE: IF CORESENSE NOT USED
ADD SS MODULE ABOVE , ADD JUMPER TO OIL SW.(M AND 2)

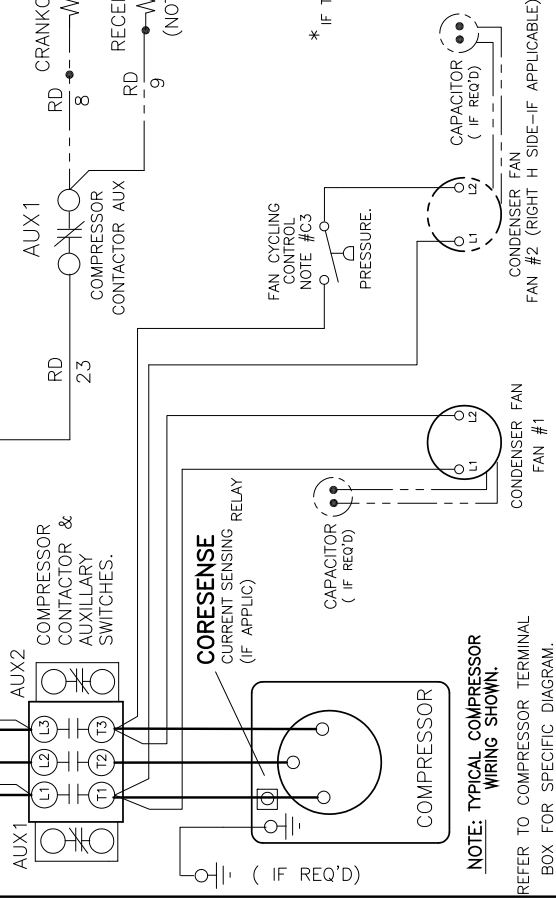

NOTE: TYPICAL COMPRESSOR WIRING SHOWN.
REFER TO COMPRESSOR TERMINAL BOX FOR SPECIFIC DIAGRAM.

NOTES

- C1. USE COPPER CONDUCTORS ONLY
 - C2. USE 75°C WIRE (OR HIGHER)
 - C3. OPTIONAL COMPONENT
 - C4. ALL FUSES TO BE CLASS CC OR J AND VOLTAGE RATED EQUAL (OR HIGHER) THAN OPERATING VOLTAGE CONDUCTORS/WIRING
- FACTORY WIRING
 - - - - - OPTIONAL WIRING
 - - - - - WIRING BY OTHERS
 ALL FIELD WIRING MUST BE DONE IN COMPLIANCE WITH ALL APPLICABLE LOCAL AND NATIONAL CODES.

REVISIONS		DIAGRAM NUMBER	
DATE	LTR	T4L1A	
APR7/17	B		
may28/09	A		

Evaporator Wiring Diagram – KA101

TYPICAL EVAPORATOR WIRING: FOR SINGLE AIR DEFROST EVAPORATOR – SINGLE POINT

FOR USE WITH: 208/230-1-60, 200/220-1-50 OR 208/230-3-60, 200/220-3-50 CONDENSING UNITS WITH OR WITHOUT DEFROST TIME CLOCK AND FOR TOTAL EVAP FAN AMPS NOT EXCEEDING 12A

CONDENSING UNIT CONTROL PANEL REFER TO COND. UNIT WIRING SECTION ABOVE

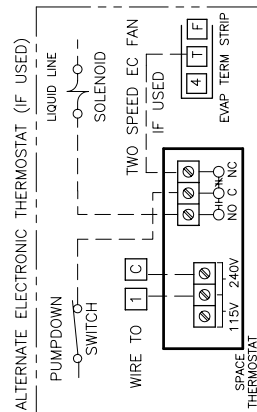
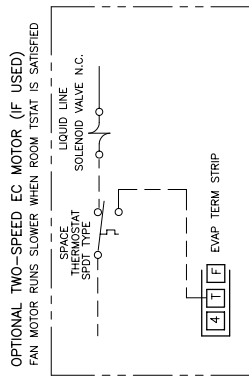
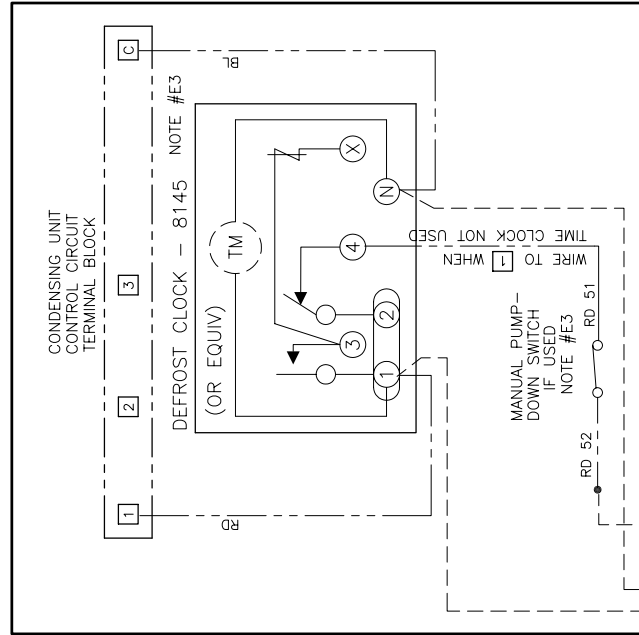

WARNING-- FOR PRE-INSTALLED ROOM T'STATS

** FIELD MODIFICATION MAY BE REQUIRED

- WHEN DEFROST TIME CLOCK IS REQUIRED, REMOVE THERMOSTAT WIRE FROM TERMINAL 4 IN UNIT COOLER, AND WIRE TO TERMINAL 4 IN TIME CLOCK, OR IF MANUAL PUMP-DOWN SWITCH FEATURE IS ALSO REQUIRED, WIRE TO SWITCH AS SHOWN

NOTES

- E1. USE COPPER CONDUCTORS ONLY
- E2. USE 75°C WIRE (OR HIGHER)
- E3. OPTIONAL COMPONENT. MAY BE FACTORY INSTALLED IN COND. UNIT, EVAPORATOR, OR SUPPLIED BY OTHERS.
- E5. OVERCURRENT PROTECTION FOR EVAPORATOR MUST NOT EXCEED MAXIMUM VALUE SHOWN ON EVAPORATOR NAMEPLATE.
- E6. ALL FUSES TO BE CLASS CC OR J AND VOLTAGE RATED EQUAL (OR HIGHER) THAN OPERATING VOLTAGE

TERMINALS

- -COMPONENT TERMINAL – MARKED
- -COMPONENT TERMINAL – UNMARKED (IDENTIFIABLE BY LOCATION)
- -COMPONENT TERMINAL – UNMARKED (UNIDENTIFIABLE)
- -TERMINAL BLOCK TERMINAL
- -WIRE SPLICE

CONDUCTORS/WIRING

- FACTORY WIRING
- WIRING BY OTHERS
- OPTIONAL COMPONENT WIRING (SOME OPTIONAL COMPONENTS MAY BE FACTORY WIRED.)

ALL FIELD WIRING MUST BE DONE IN COMPLIANCE WITH ALL APPLICABLE LOCAL AND NATIONAL CODES.

CUSTOMER

COND UNIT MODEL #	—
EVAPORATOR MODEL #	—
CUSTOMER ORDER #	—
PRODUCTION #	—
REVISIONS	
DATE	LTR
JAN 18 / 10	D
MAR26/03	A
DIAGRAM NUMBER	
KA101	

EVAPORATOR REFER TO NAMEPLATE FOR ELECTRICAL REQUIREMENTS
208/230-1-60
200/220-1-50
SEE NOTE #E5

Evaporator Wiring Diagram – LPE201

TYPICAL EVAPORATOR WIRING:

FOR TWO SINGLE LOW PROFILE ELECT DEF 230V 1 PH. EVAPORATORS—SINGLE POINT MAX TOTAL EVAP FAN AMPS—10A

FOR USE WITH: 230V SINGLE OR THREE PHASE CONDENSING UNITS WITH DEFROST TIME CLOCK, AND DEFROST HEATER CONTACTOR

CONDENSING UNIT CONTROL PANEL

REFER TO COND. UNIT WIRING SECTION ABOVE
DEFROST HEATER ELECTRICAL SERVICE FROM COMPRESSOR CONTACTOR L1, AND L2* OR POWER DISTRIBUTION TERM. BLOCK (IF REQD)

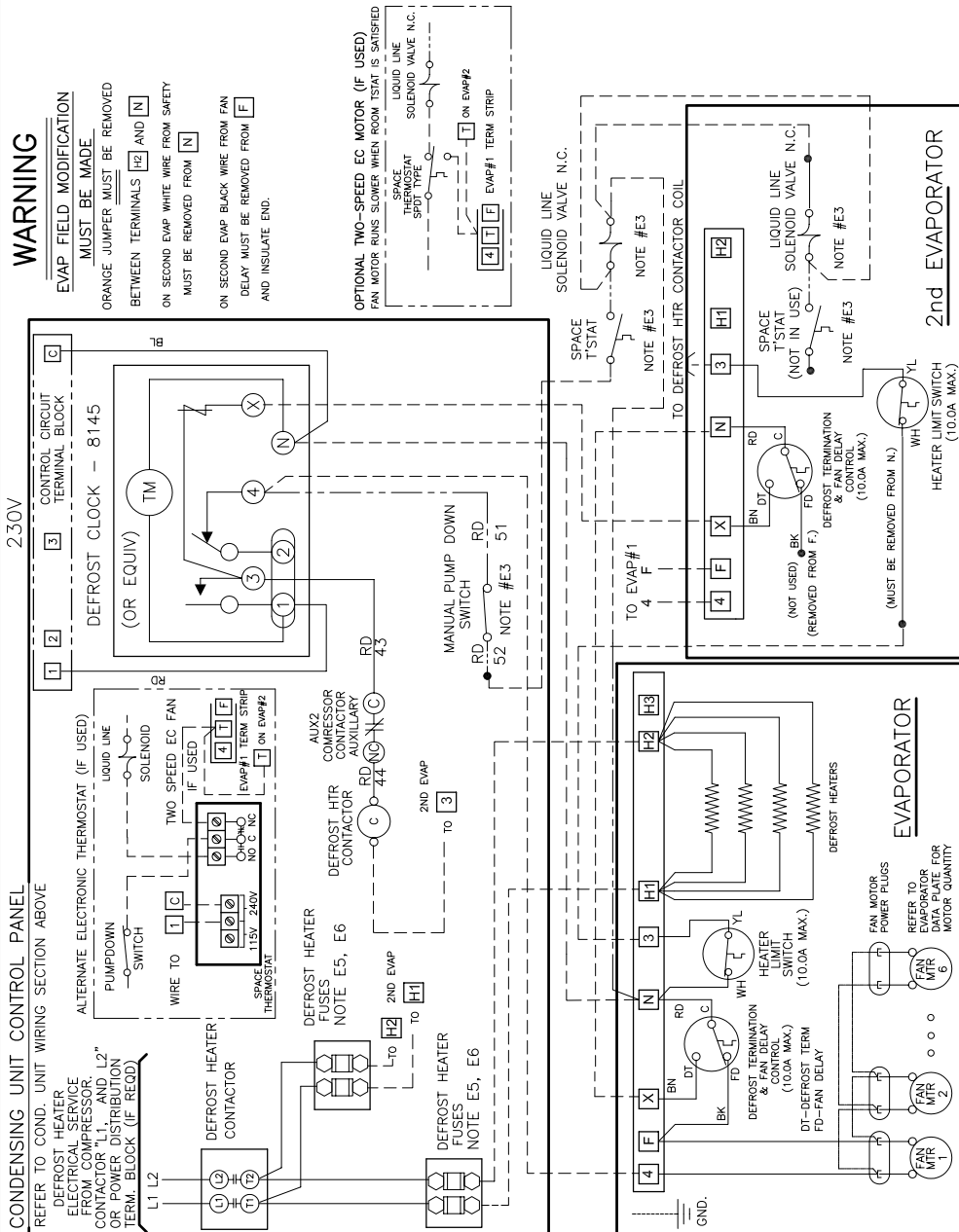

WARNING

EVAP FIELD MODIFICATION
MUST BE MADE
ORANGE JUMPER MUST BE REMOVED
BETWEEN TERMINALS H2 AND N
ON SECOND EVAP WHITE WIRE FROM FAN
MUST BE REMOVED FROM N
ON SECOND EVAP BLACK WIRE FROM FAN
DELAY MUST BE REMOVED FROM F
AND INSULATE END.

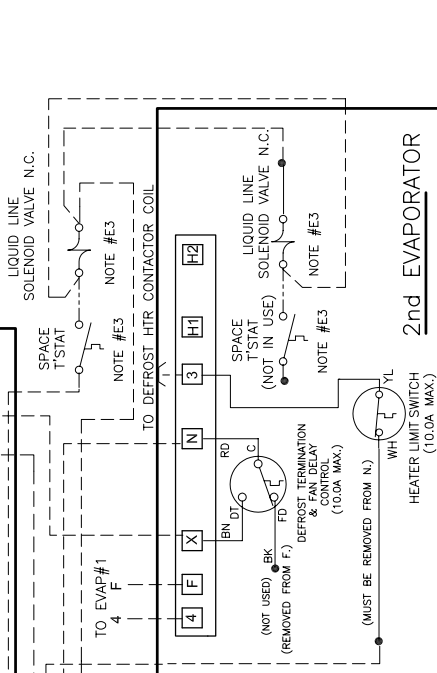
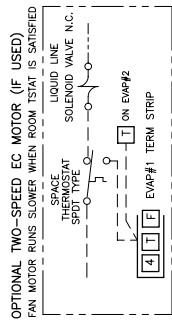

NOTES

- E1. USE COPPER CONDUCTORS ONLY
- E2. USE 75°C WIRE (OR HIGHER)
- E3. OPTIONAL COMPONENT. MAY BE FACTORY INSTALLED IN COND. UNIT, EVAPORATOR, OR SUPPLIED BY OTHERS.
- E4. HEATER LOADS ARE NOT CONCURRENT WITH REFRIGERATION LOAD
- E5. OVERCURRENT PROTECTION FOR EVAPORATOR MUST NOT EXCEED MAXIMUM VALUE SHOWN ON EVAPORATOR NAMEPLATE.
- E6. ALL FUSES TO BE CLASS CC OR J AND VOLTAGE RATED EQUAL (OR HIGHER) THAN OPERATING VOLTAGE

TERMINALS

- -COMPONENT TERMINAL - MARKED
- -COMPONENT TERMINAL - UNMARKED (IDENTIFIABLE BY LOCATION)
- -COMPONENT TERMINAL - UNMARKED (UNIDENTIFIABLE)
- -TERMINAL BLOCK TERMINAL
- -WIRE SPLICE

CONDUCTORS/WIRING

- FACTORY WIRING
- WIRING BY OTHERS
- - - OPTIONAL COMPONENT WIRING (SOME OPTIONAL COMPONENTS MAY BE FACTORY WIRED.)

ALL FIELD WIRING MUST BE DONE IN COMPLIANCE WITH ALL APPLICABLE LOCAL AND NATIONAL CODES.

CUSTOMER

COND UNIT MODEL #	-
EVAPORATOR MODEL #	-
CUSTOMER ORDER #	-
PRODUCTION #	-
REVISIONS	DIAGRAM NUMBER
DATE	LTR
JAN 18/10	E
FEB21/08	BM
LPE201	

Evaporator Wiring Diagram – JE101A

TYPICAL EVAPORATOR WIRING: FOR (1) ONE, THREE PHASE MED PROFILE ELECT DEFROST EVAPORATOR – SINGLE POINT

FOR USE WITH: THREE PHASE CONDENSING UNITS WITH DEFROST TIME CLOCK, & EVAP FAN AND DEFR. HTR. CONTACTORS.

CONDENSING UNIT CONTROL PANEL

REFER TO COND. UNIT WIRING SECTION ABOVE

DEFROST HEATER AND
EVAPORATOR FAN MOTOR
ELECTRICAL SERVICE
FROM COMPRESSOR
CONTACTOR
L1, L2 AND L3
OR POWER DISTRIBUTION
TERM. BLOCK (IF REQD)

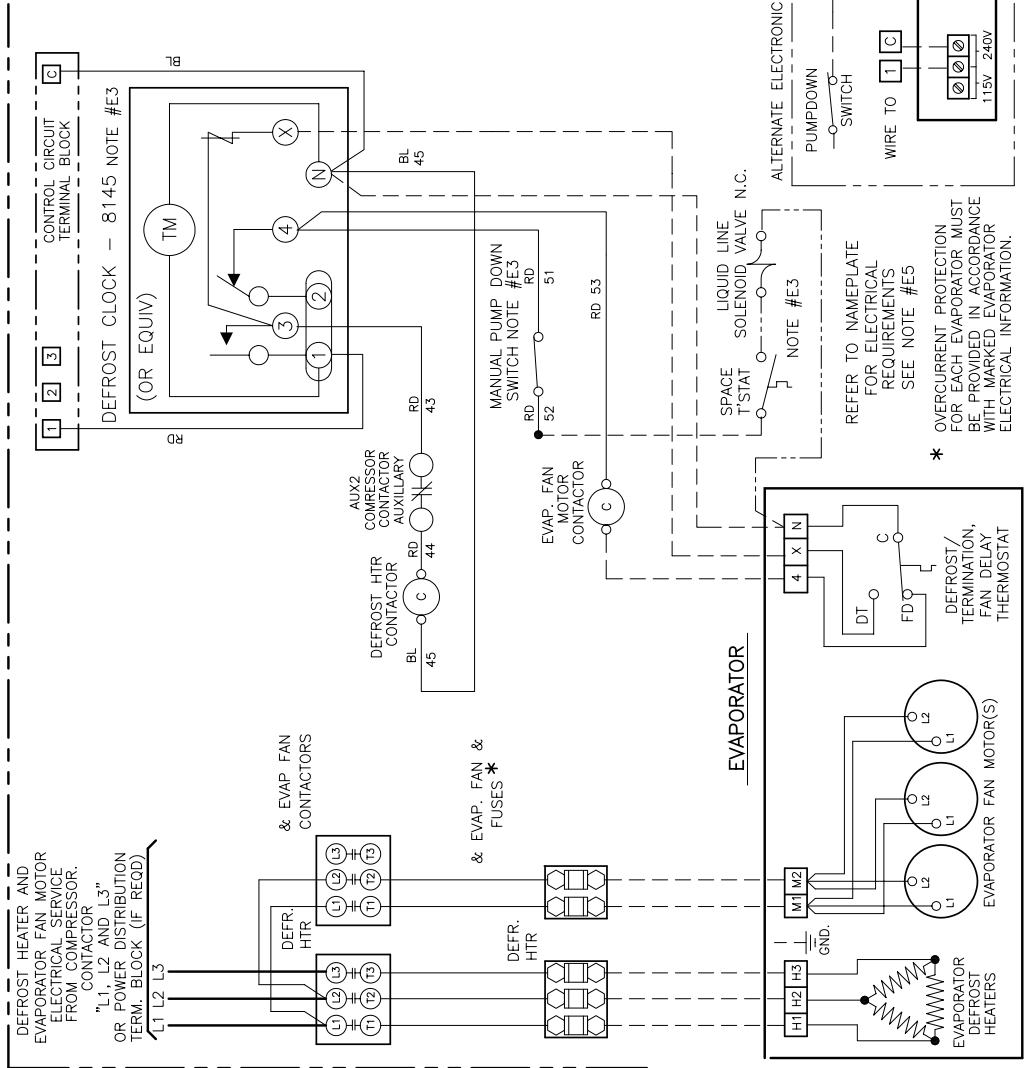

NOTES

- E1. USE COPPER CONDUCTORS ONLY
- E2. USE 75°C WIRE (OR HIGHER)
- E3. OPTIONAL COMPONENT. MAY BE FACTORY INSTALLED IN COND. UNIT, EVAPORATOR, OR SUPPLIED BY OTHERS.
- E4. HEATER LOADS ARE NOT CONCURRENT WITH REFRIGERATION LOAD
- E5. OVERCURRENT PROTECTION FOR EVAPORATOR MUST NOT EXCEED MAXIMUM VALUE SHOWN ON EVAPORATOR NAMEPLATE.
- E6. ALL FUSES TO BE CLASS CC OR J AND VOLTAGE RATED EQUAL (OR HIGHER) THAN OPERATING VOLTAGE

TERMINALS

- –COMPONENT TERMINAL – MARKED
- –COMPONENT TERMINAL – UNMARKED (IDENTIFIABLE BY LOCATION)
- –COMPONENT TERMINAL – UNMARKED (UNIDENTIFIABLE)
- –TERMINAL BLOCK TERMINAL
- –WIRE SPLICE

CONDUCTORS/WIRING

- FACTORY WIRING
- - - WIRING BY OTHERS
- - - OPTIONAL COMPONENT WIRING (SOME OPTIONAL COMPONENTS MAY BE FACTORY WIRED.)

ALL FIELD WIRING MUST BE DONE IN COMPLIANCE WITH ALL APPLICABLE LOCAL AND NATIONAL CODES.

CUSTOMER

COND UNIT MODEL #	—
EVAPORATOR MODEL #	—
CUSTOMER ORDER #	—
PRODUCTION #	—
REVISIONS	
DATE	LTR
JUNE 14/10	D
MAR26/03	A
DIAGRAM NUMBER	
JE101A	

FEB4/13 F

Evaporator Wiring Diagram – JE201A

TYPICAL EVAPORATOR WIRING: FOR TWO MED PROFILE ELECT DEFROST EVAPORATORS— SINGLE POINT

FOR USE WITH: THREE PHASE CONDENSING UNITS WITH DEFROST TIME CLOCK, & EVAP FAN AND DEFR. HTR. CONTACTORS.

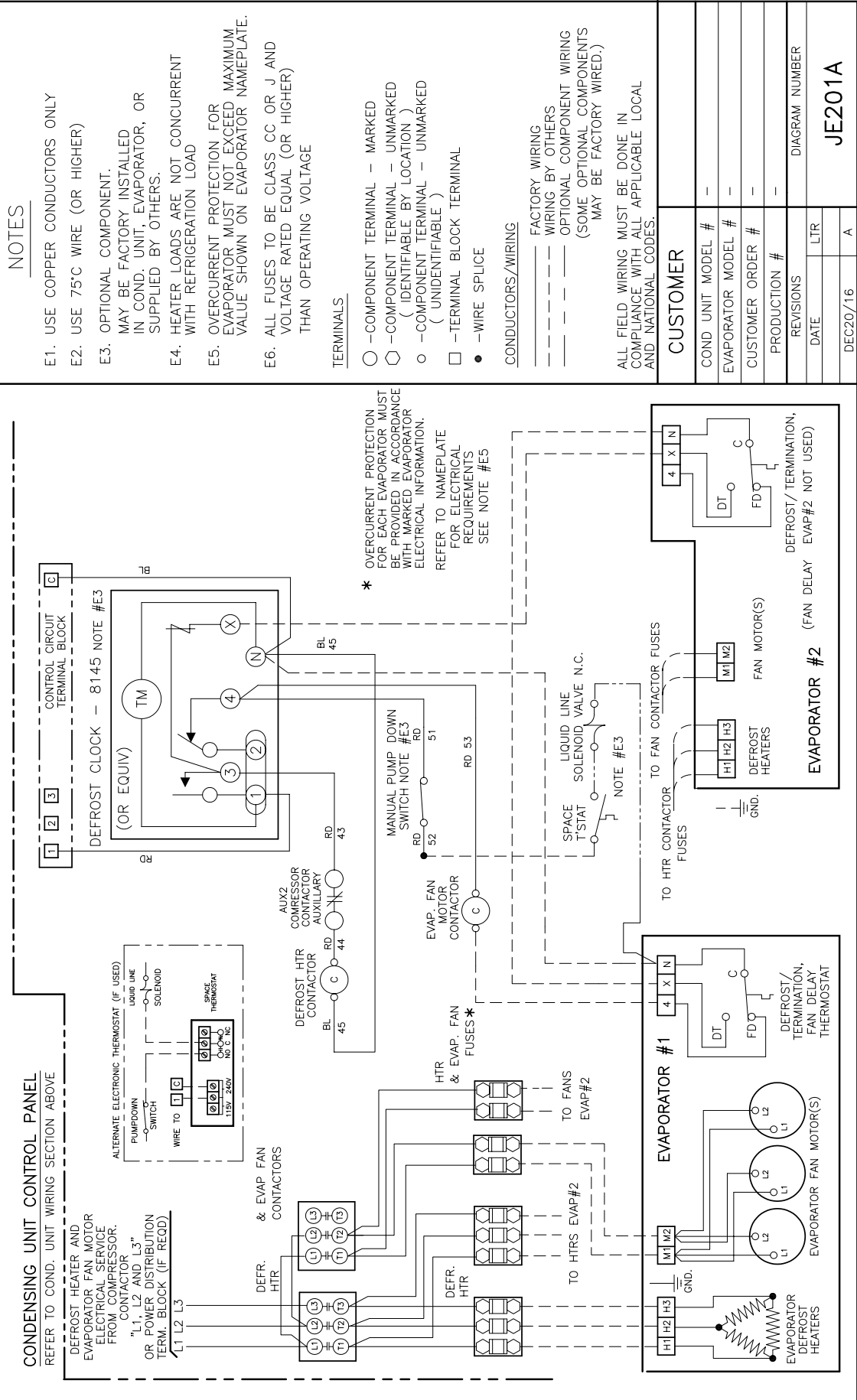

Appendix B:

Refrigerant Line Sizing Charts

REFRIGERANT LINE SIZING CHARTS

R134a

Capacity BTU/Hr.	R134a Suction Line Size from Evaporator to Compressor R134a																									Liquid Line Size					
	+45°F SST Equivalent Length					+25°F SST Equivalent Length					+0°F SST Equivalent Length					-20°F SST Equivalent Length					-40°F SST Equivalent Length					Receiver to TXV Equivalent Length					
	25'	50'	75'	100'	150'	25'	50'	75'	100'	150'	25'	50'	75'	100'	150'	25'	50'	75'	100'	150'	25'	50'	75'	100'	150'	25'	50'	75'	100'	150'	
2000	3/8	3/8	3/8	1/2	1/2	3/8	1/2	1/2	1/2	1/2	1/2	1/2	5/8	5/8	5/8	7/8	7/8	7/8	7/8	7/8	7/8	3/8	7/8	7/8	1-1/8	5/16	5/16	5/16	5/16	5/16	
3000	3/8	1/2	1/2	1/2	1/2	1/2	1/2	1/2	5/8	5/8	1/2	5/8	5/8	7/8	7/8	5/8	7/8	7/8	7/8	7/8	7/8	1/8	7/8	1-1/8	1-1/8	1-1/8	5/16	5/16	5/16	5/16	5/16
4000	1/2	1/2	1/2	1/2	5/8	1/2	5/8	5/8	5/8	5/8	5/8	5/8	7/8	7/8	7/8	7/8	7/8	7/8	7/8	1-1/8	7/8	1-1/8	1-1/8	1-1/8	1-1/8	5/16	5/16	5/16	5/16	5/16	
6000	1/2	5/8	5/8	5/8	5/8	5/8	5/8	7/8	7/8	7/8	5/8	7/8	7/8	7/8	1-1/8	7/8	7/8	1-1/8	1-1/8	1-1/8	1-1/8	1-1/8	1-1/8	1-1/8	1-1/8	5/16	5/16	5/16	5/16	5/16	
9000	5/8	5/8	5/8	7/8	7/8	5/8	7/8	7/8	7/8	7/8	7/8	7/8	1-1/8	1-1/8	1-1/8	7/8	1-1/8	1-1/8	1-1/8	1-3/8	1-1/8	1-3/8	1-3/8	1-3/8	1-1/8	5/16	5/16	5/16	5/16	3/8	
12000	5/8	7/8	7/8	7/8	7/8	7/8	7/8	7/8	7/8	1-1/8	7/8	1-1/8	1-1/8	1-1/8	1-1/8	1-1/8	1-3/8	1-3/8	1-3/8	1-3/8	1-3/8	1-3/8	1-3/8	1-3/8	1-3/8	3/8	3/8	3/8	3/8	3/8	
15000	5/8	7/8	7/8	7/8	7/8	7/8	7/8	7/8	1-1/8	1-1/8	7/8	1-1/8	1-1/8	1-1/8	1-3/8	1-1/8	1-3/8	1-3/8	1-3/8	1-5/8	1-3/8	1-5/8	1-5/8	2-1/8	2-1/8	3/8	3/8	3/8	3/8	1/2	
18000	7/8	7/8	7/8	7/8	1-1/8	7/8	7/8	1-1/8	1-1/8	1-1/8	1-1/8	1-1/8	1-3/8	1-3/8	1-3/8	1-1/8	1-3/8	1-3/8	1-5/8	1-5/8	1-3/8	1-5/8	2-1/8	2-1/8	2-1/8	3/8	3/8	3/8	1/2	1/2	
24000	7/8	7/8	1-1/8	1-1/8	1-1/8	7/8	1-1/8	1-1/8	1-1/8	1-3/8	1-1/8	1-3/8	1-3/8	1-3/8	1-5/8	1-3/8	1-5/8	1-5/8	1-5/8	2-1/8	1-5/8	1-5/8	2-1/8	2-1/8	2-1/8	3/8	3/8	1/2	1/2	1/2	
30000	7/8	1-1/8	1-1/8	1-1/8	1-1/8	1-1/8	1-1/8	1-1/8	1-3/8	1-3/8	1-1/8	1-3/8	1-3/8	1-5/8	1-5/8	1-3/8	1-5/8	2-1/8	2-1/8	2-1/8	1-5/8	2-1/8	2-1/8	2-5/8	2-5/8	1/2	1/2	1/2	1/2	1/2	
36000	7/8	1-1/8	1-1/8	1-1/8	1-3/8	1-1/8	1-1/8	1-3/8	1-3/8	1-3/8	1-3/8	1-3/8	1-5/8	1-5/8	2-1/8	1-5/8	1-5/8	2-1/8	2-1/8	2-1/8	2-1/8	2-1/8	2-1/8	2-5/8	2-5/8	1/2	1/2	1/2	1/2	5/8	
48000	1-1/8	1-1/8	1-1/8	1-3/8	1-3/8	1-1/8	1-3/8	1-3/8	1-5/8	1-5/8	1-3/8	1-5/8	1-5/8	2-1/8	2-1/8	1-5/8	2-1/8	2-1/8	2-1/8	2-5/8	2-1/8	2-5/8	2-5/8	2-5/8	3-1/8	1/2	1/2	1/2	5/8	5/8	
54000	1-1/8	1-1/8	1-3/8	1-3/8	1-3/8	1-1/8	1-3/8	1-3/8	1-5/8	1-5/8	1-3/8	1-5/8	2-1/8	2-1/8	2-1/8	2-1/8	2-1/8	2-1/8	2-5/8	2-5/8	2-1/8	2-5/8	2-5/8	3-1/8	3-1/8	1/2	1/2	5/8	5/8	5/8	
60000	1-1/8	1-3/8	1-3/8	1-3/8	1-5/8	1-3/8	1-3/8	1-5/8	1-5/8	1-5/8	1-5/8	1-5/8	2-1/8	2-1/8	2-1/8	2-1/8	2-1/8	2-1/8	2-5/8	2-5/8	2-1/8	2-5/8	2-5/8	3-1/8	3-1/8	1/2	1/2	5/8	5/8	5/8	
66000	1-1/8	1-3/8	1-3/8	1-3/8	1-5/8	1-3/8	1-3/8	1-5/8	1-5/8	2-1/8	1-5/8	2-1/8	2-1/8	2-1/8	2-1/8	2-1/8	2-1/8	2-5/8	2-5/8	2-5/8	2-5/8	2-5/8	2-5/8	3-1/8	3-1/8	1/2	5/8	5/8	5/8	7/8	
72000	1-1/8	1-3/8	1-3/8	1-5/8	1-5/8	1-3/8	1-5/8	1-5/8	1-5/8	2-1/8	1-5/8	2-1/8	2-1/8	2-1/8	2-5/8	2-1/8	2-1/8	2-5/8	2-5/8	2-5/8	2-5/8	2-5/8	2-5/8	3-1/8	3-1/8	1/2	5/8	5/8	5/8	7/8	
78000	1-1/8	1-3/8	1-3/8	1-5/8	1-5/8	1-3/8	1-5/8	1-5/8	2-1/8	2-1/8	1-5/8	2-1/8	2-1/8	2-1/8	2-5/8	2-1/8	2-5/8	2-5/8	2-5/8	3-1/8	2-5/8	3-1/8	3-1/8	3-1/8	3-5/8	1/2	5/8	5/8	5/8	7/8	
84000	1-1/8	1-3/8	1-5/8	1-5/8	1-5/8	1-3/8	1-5/8	1-5/8	2-1/8	2-1/8	1-5/8	2-1/8	2-1/8	2-1/8	2-5/8	2-1/8	2-5/8	2-5/8	2-5/8	3-1/8	2-5/8	3-1/8	3-1/8	3-5/8	3-5/8	1/2	5/8	5/8	7/8	7/8	
90000	1-3/8	1-3/8	1-5/8	1-5/8	1-5/8	1-3/8	1-5/8	2-1/8	2-1/8	2-1/8	2-1/8	2-1/8	2-1/8	2-5/8	2-5/8	2-1/8	2-5/8	2-5/8	2-5/8	3-1/8	2-5/8	3-1/8	3-1/8	3-5/8	3-5/8	1/2	5/8	5/8	7/8	7/8	
120000	1-3/8	1-5/8	1-5/8	2-1/8	2-1/8	1-5/8	2-1/8	2-1/8	2-1/8	2-1/8	2-1/8	2-1/8	2-5/8	2-5/8	2-5/8	2-5/8	2-5/8	3-1/8	3-1/8	3-5/8	3-1/8	3-1/8	3-5/8	3-5/8	4-1/8	5/8	7/8	7/8	7/8	7/8	
150000	1-3/8	1-5/8	2-1/8	2-1/8	2-1/8	1-5/8	2-1/8	2-1/8	2-1/8	2-5/8	2-1/8	2-5/8	2-5/8	3-1/8	2-5/8	3-1/8	3-1/8	3-5/8	3-5/8	4-1/8	3-5/8	3-5/8	4-1/8	4-1/8	5-1/8	5/8	7/8	7/8	7/8	7/8	
180000	1-5/8	2-1/8	2-1/8	2-1/8	2-1/8	2-1/8	2-1/8	2-1/8	2-5/8	2-5/8	2-1/8	2-5/8	2-5/8	3-1/8	3-1/8	2-5/8	3-1/8	3-5/8	3-5/8	4-1/8	3-5/8	3-5/8	4-1/8	5-1/8	5-1/8	7/8	7/8	7/8	7/8	1-1/8	
210000	1-5/8	2-1/8	2-1/8	2-1/8	2-5/8	2-1/8	2-1/8	2-5/8	2-5/8	2-5/8	2-5/8	2-5/8	3-1/8	3-1/8	3-5/8	3-1/8	3-1/8	3-5/8	3-5/8	4-1/8	3-5/8	4-1/8	5-1/8	5-1/8	5-1/8	7/8	7/8	7/8	7/8	1-1/8	
240000	2-1/8	2-1/8	2-1/8	2-5/8	2-5/8	2-1/8	2-5/8	2-5/8	2-5/8	3-1/8	2-5/8	3-1/8	3-1/8	3-1/8	3-5/8	3-1/8	3-5/8	3-5/8	4-1/8	4-1/8	3-5/8	4-1/8	5-1/8	5-1/8	5-1/8	7/8	7/8	7/8	1-1/8	1-1/8	
300000	2-1/8	2-1/8	2-5/8	2-5/8	2-5/8	2-1/8	2-5/8	2-5/8	3-1/8	3-1/8	2-5/8	3-1/8	3-5/8	3-5/8	4-1/8	3-1/8	3-5/8	4-1/8	4-1/8	5-1/8	4-1/8	5-1/8	5-1/8	5-1/8	6-1/8	7/8	7/8	1-1/8	1-1/8	1-1/8	
360000	2-1/8	2-5/8	2-5/8	2-5/8	3-1/8	2-5/8	2-5/8	3-1/8	3-1/8	3-5/8	3-1/8	3-1/8	3-5/8	3-5/8	4-1/8	3-5/8	4-1/8	4-1/8	5-1/8	5-1/8	4-1/8	5-1/8	5-1/8	6-1/8	6-1/8	7/8	1-1/8	1-1/8	1-1/8	1-3/8	
480000	2-1/8	2-5/8	2-5/8	3-1/8	3-1/8	2-5/8	3-1/8	3-1/8	3-5/8	3-5/8	3-1/8	3-5/8	4-1/8	4-1/8	5-1/8	4-1/8	5-1/8	5-1/8	5-1/8	6-1/8	5-1/8	6-1/8	6-1/8	6-1/8	8-1/8	1-1/8	1-1/8	1-1/8	1-3/8	1-3/8	
600000	2-5/8	3-1/8	3-1/8	3-1/8	3-5/8	3-1/8	3-1/8	3-5/8	3-5/8	4-1/8	3-5/8	4-1/8	4-1/8	5-1/8	5-1/8	4-1/8	5-1/8	5-1/8	6-1/8	6-1/8	5-1/8	6-1/8	8-1/8	8-1/8	1-1/8	1-1/8	1-3/8	1-3/8	1-3/8		

- Notes:**
- Line sizes are calculated at 100% system capacity
 - Suction lines sized based on a maximum total pressure drop equivalent to 2°F
 - Sizing is based on 65°F return gas at compressor with a liquid temperature of 100°F
 - Line sizes are O.D. using type 'L' copper tubing.
 - Follow proper piping practices to ensure proper oil return, including proper slopes, traps and supporting.
 - Double suction risers might be necessary with cylinder unloading. Consult factory if unsure.

REFRIGERANT LINE SIZING CHARTS

R404A R507

Capacity BTU/Hr.	R404A R507 Suction Line Size from Evaporator to Compressor															R404A R507					Liquid Line Size													
	+45°F SST Equivalent Length					+25°F SST Equivalent Length					+0°F SST Equivalent Length					-20°F SST Equivalent Length					-40°F SST Equivalent Length					Receiver to TXV Equivalent Length								
	25'	50'	75'	100'	150'	25'	50'	75'	100'	150'	25'	50'	75'	100'	150'	25'	50'	75'	100'	150'	25'	50'	75'	100'	150'	25'	50'	75'	100'	150'				
2000	5/16	3/8	3/8	3/8	3/8	3/8	3/8	3/8	1/2	1/2	1/2	1/2	1/2	1/2	1/2	1/2	1/2	5/8	5/8	5/8	5/8	5/8	5/8	5/8	5/8	5/8	5/8	7/8	7/8	3/8	3/8	3/8	3/8	3/8
3000	5/16	3/8	3/8	3/8	1/2	3/8	3/8	1/2	1/2	1/2	1/2	1/2	1/2	5/8	5/8	5/8	1/2	5/8	5/8	7/8	7/8	5/8	7/8	7/8	7/8	7/8	7/8	7/8	7/8	3/8	3/8	3/8	3/8	3/8
4000	5/16	3/8	1/2	1/2	1/2	1/2	1/2	1/2	1/2	5/8	1/2	5/8	5/8	5/8	7/8	5/8	5/8	7/8	7/8	7/8	7/8	7/8	7/8	7/8	7/8	7/8	7/8	1-1/8	3/8	3/8	3/8	3/8	3/8	
6000	1/2	1/2	1/2	1/2	5/8	1/2	1/2	5/8	5/8	5/8	5/8	5/8	7/8	7/8	7/8	5/8	7/8	7/8	7/8	7/8	7/8	7/8	7/8	7/8	7/8	7/8	1-1/8	1-1/8	1-1/8	3/8	3/8	3/8	3/8	3/8
9000	1/2	1/2	5/8	5/8	5/8	5/8	5/8	5/8	7/8	7/8	5/8	7/8	7/8	7/8	7/8	7/8	7/8	7/8	1-1/8	1-1/8	7/8	1-1/8	1-1/8	1-1/8	1-1/8	1-1/8	1-1/8	1-3/8	3/8	3/8	3/8	3/8	3/8	
12000	1/5	5/8	5/8	5/8	7/8	5/8	7/8	7/8	7/8	7/8	7/8	7/8	7/8	7/8	1-1/8	7/8	1-1/8	1-1/8	1-1/8	1-1/8	1-1/8	1-1/8	1-1/8	1-1/8	1-1/8	1-1/8	1-3/8	1-3/8	1-3/8	3/8	3/8	3/8	3/8	3/8
15000	5/8	5/8	7/8	7/8	7/8	5/8	7/8	7/8	7/8	7/8	7/8	7/8	7/8	1-1/8	1-1/8	1-1/8	7/8	1-1/8	1-1/8	1-1/8	1-3/8	1/1/8	1-3/8	1-3/8	1-3/8	1-5/8	1-5/8	3/8	3/8	3/8	3/8	1/2		
18000	5/8	7/8	7/8	7/8	7/8	7/8	7/8	7/8	7/8	1-1/8	7/8	7/8	1-1/8	1-1/8	1-1/8	1-1/8	1-1/8	1-1/8	1-3/8	1-3/8	1-1/8	1-3/8	1-3/8	1-5/8	1-5/8	1-5/8	1-5/8	3/8	1/2	1/2	1/2	1/2		
24000	5/8	7/8	7/8	7/8	7/8	7/8	7/8	7/8	1-1/8	1-1/8	7/8	1-1/8	1-1/8	1-1/8	1-3/8	1-1/8	1-3/8	1-3/8	1-3/8	1-5/8	1-3/8	1-5/8	1-5/8	1-5/8	1-5/8	2-1/8	2-1/8	1/2	1/2	1/2	1/2	1/2		
30000	7/8	7/8	7/8	7/8	1-1/8	7/8	7/8	1-1/8	1-1/8	1-1/8	1-1/8	1-1/8	1-1/8	1-3/8	1-3/8	1-3/8	1-1/8	1-3/8	1-3/8	1-5/8	1-5/8	1-3/8	1-5/8	1-5/8	1-5/8	2-1/8	2-1/8	1/2	1/2	1/2	1/2	1/2		
36000	7/8	7/8	1-1/8	1-1/8	1-1/8	7/8	1-1/8	1-1/8	1-1/8	1-3/8	1-1/8	1-1/8	1-3/8	1-3/8	1-5/8	1-3/8	1-3/8	1-5/8	1-5/8	2-1/8	1-5/8	1-5/8	1-5/8	2-1/8	2-1/8	2-1/8	2-1/8	1/2	1/2	1/2	1/2	5/8		
48000	7/8	1-1/8	1-1/8	1-1/8	1-1/8	1-1/8	1-1/8	1-1/8	1-3/8	1-3/8	1-1/8	1-3/8	1-3/8	1-5/8	1-5/8	1-3/8	1-5/8	1-5/8	2-1/8	2-1/8	1-5/8	2-1/8	2-1/8	2-1/8	2-1/8	2-5/8	1/2	1/2	5/8	5/8	5/8			
54000	7/8	1-1/8	1-1/8	1-1/8	1-3/8	1-1/8	1-1/8	1-3/8	1-3/8	1-3/8	1-3/8	1-3/8	1-3/8	1-5/8	1-5/8	1-3/8	1-5/8	2-1/8	2-1/8	2-1/8	1-5/8	2-1/8	2-1/8	2-1/8	2-5/8	1/2	1/2	5/8	5/8	5/8				
60000	1-1/8	1-1/8	1-1/8	1-1/8	1-3/8	1-1/8	1-1/8	1-3/8	1-3/8	1-5/8	1-3/8	1-3/8	1-5/8	1-5/8	2-1/8	1-5/8	1-5/8	2-1/8	2-1/8	2-1/8	2-1/8	2-1/8	2-1/8	2-5/8	2-5/8	1/2	5/8	5/8	5/8	5/8				
66000	1-1/8	1-1/8	1-1/8	1-3/8	1-3/8	1-1/8	1-3/8	1-3/8	1-3/8	1-5/8	1-3/8	1-5/8	1-5/8	1-5/8	2-1/8	1-5/8	2-1/8	2-1/8	2-1/8	2-1/8	2-1/8	2-1/8	2-1/8	2-5/8	2-5/8	1/2	5/8	5/8	5/8	7/8				
72000	1-1/8	1-1/8	1-1/8	1-3/8	1-3/8	1-1/8	1-3/8	1-3/8	1-3/8	1-5/8	1-3/8	1-5/8	1-5/8	2-1/8	2-1/8	1-5/8	2-1/8	2-1/8	2-1/8	2-1/8	2-1/8	2-1/8	2-1/8	2-5/8	2-5/8	1/2	5/8	5/8	5/8	7/8				
78000	1-1/8	1-1/8	1-3/8	1-3/8	1-3/8	1-1/8	1-3/8	1-3/8	1-5/8	1-5/8	1-3/8	1-5/8	1-5/8	2-1/8	2-1/8	1-5/8	2-1/8	2-1/8	2-1/8	2-5/8	2-1/8	2-1/8	2-5/8	2-5/8	3-1/8	1/2	5/8	5/8	7/8	7/8				
84000	1-1/8	1-1/8	1-3/8	1-3/8	1-3/8	1-1/8	1-3/8	1-3/8	1-5/8	1-5/8	1-3/8	1-5/8	2-1/8	2-1/8	2-1/8	1-5/8	2-1/8	2-1/8	2-1/8	2-5/8	2-1/8	2-5/8	2-5/8	2-5/8	3-1/8	1/2	5/8	5/8	7/8	7/8				
90000	1-3/8	1-3/8	1-3/8	1-3/8	1-5/8	1-3/8	1-3/8	1-5/8	1-5/8	1-5/8	1-3/8	1-5/8	2-1/8	2-1/8	2-1/8	1-5/8	2-1/8	2-1/8	2-1/8	2-5/8	2-1/8	2-5/8	2-5/8	2-5/8	3-1/8	5/8	5/8	7/8	7/8	7/8				
120000	1-3/8	1-3/8	1-3/8	1-5/8	1-5/8	1-3/8	1-5/8	1-5/8	2-1/8	2-1/8	1-5/8	2-1/8	2-1/8	2-1/8	2-5/8	2-1/8	2-1/8	2-5/8	2-5/8	2-5/8	2-5/8	2-5/8	2-5/8	3-1/8	3-1/8	3-1/8	5/8	7/8	7/8	7/8	7/8			
150000	1-5/8	1-5/8	1-5/8	2-1/8	2-1/8	1-3/8	1-5/8	2-1/8	2-1/8	2-1/8	2-1/8	2-1/8	2-1/8	2-5/8	2-5/8	2-1/8	2-5/8	2-5/8	2-5/8	3-1/8	2-5/8	3-1/8	3-1/8	3-1/8	3-5/8	5/8	7/8	7/8	7/8	7/8				
180000	1-5/8	1-5/8	2-1/8	2-1/8	2-1/8	1-5/8	2-1/8	2-1/8	2-1/8	2-1/8	2-1/8	2-1/8	2-1/8	2-5/8	2-5/8	2-5/8	2-1/8	2-5/8	2-5/8	3-1/8	3-1/8	2-5/8	3-1/8	3-5/8	3-5/8	7/8	7/8	7/8	7/8	1/1/8				
210000	1-5/8	2-1/8	2-1/8	2-1/8	2-1/8	1-5/8	2-1/8	2-1/8	2-1/8	2-5/8	2-1/8	2-5/8	2-5/8	2-5/8	3-1/8	2-5/8	2-5/8	3-1/8	3-1/8	3-5/8	3-1/8	3-1/8	3-5/8	3-5/8	4-1/8	7/8	7/8	7/8	1-1/8	1-1/8				
240000	1-5/8	2-1/8	2-1/8	2-1/8	2-1/8	1-5/8	2-1/8	2-1/8	2-1/8	2-5/8	2-1/8	2-5/8	2-5/8	2-5/8	3-1/8	2-5/8	3-1/8	3-1/8	3-1/8	3-5/8	3-1/8	3-5/8	3-5/8	4-1/8	4-1/8	7/8	7/8	1-1/8	1/1/8	1/1/8				
300000	2-1/8	2-1/8	2-1/8	2-5/8	2-5/8	2-1/8	2-1/8	2-5/8	2-5/8	2-5/8	2-1/8	2-5/8	3-1/8	3-1/8	3-1/8	2-5/8	3-1/8	3-5/8	3-5/8	3-5/8	3-1/8	3-5/8	4-1/8	4-1/8	5-1/8	7/8	1-1/8	1-1/8	1-1/8	1-1/8				
360000	2-1/8	2-1/8	2-5/8	2-5/8	3-1/8	2-1/8	2-5/8	2-5/8	2-5/8	3-1/8	2-5/8	2-5/8	3-1/8	3-1/8	3-5/8	3-1/8	3-1/8	3-5/8	3-5/8	4-1/8	3-5/8	4-1/8	4-1/8	5-1/8	5-1/8	7/8	1-1/8	1-1/8	1-1/8	1-3/8				
480000	2-1/8	2-1/8	2-5/8	2-5/8	2-5/8	2-1/8	2-5/8	2-5/8	3-1/8	3-1/8	2-5/8	3-1/8	3-5/8	3-5/8	3-5/8	3-1/8	3-5/8	4-1/8	4-1/8	5-1/8	4-1/8	5-1/8	5-1/8	5-1/8	6-1/8	1-1/8	1-1/8	1-3/8	1-3/8	1-3/8				
600000	2-1/8	2/5/8	2-5/8	2-5/8	3-1/8	2-5/8	2-5/8	3-1/8	3-1/8	3/5/8	3-1/8	3-5/8	3-5/8	3-5/8	4-1/8	3-5/8	4-1/8	4-1/8	5-1/8	4-1/8	5-1/8	5-1/8	6-1/8	6-1/8	1-1/8	1-3/8	1-3/8	1-3/8	1-3/8					

- Notes:**
- Line sizes are calculated at 100% system capacity
 - Suction lines sized based on a maximum total pressure drop equivalent to 2°F
 - Sizing is based on 65°F return gas at compressor with a liquid temperature of 100°F
 - Line sizes are O.D. using type 'L' copper tubing.
 - Follow proper piping practices to ensure proper oil return, including proper slopes, traps and supporting.
 - Double suction risers might be necessary with cylinder unloading. Consult factory if unsure.

REFRIGERANT LINE SIZING CHARTS

R407A R407C R407F

Capacity BTU/Hr.	R407A R407C R407F Suction Line Size from Evaporator to Compressor															R407A R407C R407F					Liquid Line Size													
	+45°F SST Equivalent Length					+25°F SST Equivalent Length					+0°F SST Equivalent Length					-20°F SST Equivalent Length					-40°F SST Equivalent Length					Receiver to TXV Equivalent Length								
	25'	50'	75'	100'	150'	25'	50'	75'	100'	150'	25'	50'	75'	100'	150'	25'	50'	75'	100'	150'	25'	50'	75'	100'	150'	25'	50'	75'	100'	150'				
2000	3/8	3/8	3/8	3/8	3/8	3/8	3/8	3/8	1/2	1/2	3/8	1/2	1/2	1/2	5/8	1/2	1/2	5/8	5/8	5/8	5/8	5/8	7/8	7/8	7/8	3/8	3/8	3/8	3/8	3/8				
3000	3/8	1/2	1/2	1/2	1/2	3/8	1/2	1/2	1/2	1/2	1/2	1/2	5/8	5/8	5/8	5/8	5/8	5/8	7/8	7/8	5/8	7/8	7/8	7/8	7/8	3/8	3/8	3/8	3/8	3/8				
4000	1/2	1/2	1/2	1/2	1/2	1/2	1/2	1/2	1/2	5/8	1/2	5/8	5/8	5/8	7/8	5/8	5/8	7/8	7/8	7/8	7/8	7/8	7/8	7/8	1-1/8	3/8	3/8	3/8	3/8	3/8				
6000	1/2	1/2	1/2	1/2	5/8	1/2	1/2	5/8	5/8	5/8	5/8	5/8	5/8	7/8	7/8	7/8	7/8	7/8	7/8	7/8	7/8	7/8	7/8	7/8	1-1/8	1-1/8	1-1/8	3/8	3/8	3/8	3/8	3/8		
9000	1/2	1/2	5/8	5/8	5/8	1/2	5/8	5/8	7/8	7/8	5/8	7/8	7/8	7/8	7/8	7/8	7/8	1-1/8	1-1/8	1-1/8	7/8	1-1/8	1-1/8	1-3/8	1-3/8	3/8	3/8	3/8	3/8	3/8	3/8			
12000	1/2	5/8	5/8	5/8	7/8	5/8	7/8	7/8	7/8	7/8	7/8	7/8	7/8	7/8	1-1/8	7/8	1-1/8	1-1/8	1-1/8	1-1/8	1-1/8	1-1/8	1-1/8	1-1/8	1-1/8	1-1/8	1-3/8	1-3/8	1-3/8	3/8	3/8	3/8	3/8	3/8
15000	5/8	5/8	7/8	7/8	7/8	5/8	7/8	7/8	7/8	7/8	7/8	7/8	7/8	1-1/8	1-1/8	7/8	1-1/8	1-1/8	1-1/8	1-3/8	1-1/8	1-1/8	1-3/8	1-3/8	1-1/8	1-1/8	1-3/8	1-3/8	1-5/8	3/8	3/8	3/8	3/8	3/8
18000	5/8	7/8	7/8	7/8	7/8	7/8	7/8	7/8	7/8	1-1/8	7/8	7/8	1-1/8	1-1/8	1-1/8	1-1/8	1-1/8	1-1/8	1-3/8	1-3/8	1-3/8	1-1/8	1-3/8	1-3/8	1-5/8	1-5/8	3/8	3/8	3/8	3/8	3/8	3/8	3/8	
24000	5/8	7/8	7/8	7/8	7/8	7/8	7/8	7/8	1-1/8	1-1/8	7/8	1-1/8	1-1/8	1-1/8	1-3/8	1-1/8	1-3/8	1-3/8	1-3/8	1-5/8	1-3/8	1-5/8	1-5/8	1-5/8	2-1/8	3/8	3/8	3/8	1/2	1/2	1/2	1/2	1/2	
30000	7/8	7/8	7/8	7/8	1-1/8	7/8	7/8	1-1/8	1-1/8	1-1/8	1-1/8	1-1/8	1-1/8	1-3/8	1-3/8	1-1/8	1-3/8	1-3/8	1-5/8	1-5/8	1-3/8	1-5/8	2-1/8	2-1/8	2-1/8	3/8	3/8	1/2	1/2	1/2	1/2	1/2		
36000	7/8	7/8	7/8	1-1/8	1-1/8	7/8	1-1/8	1-1/8	1-1/8	1-3/8	1-1/8	1-1/8	1-3/8	1-3/8	1-5/8	1-3/8	1-3/8	1-5/8	1-5/8	2-1/8	1-5/8	2-1/8	2-1/8	2-1/8	2-1/8	3/8	1/2	1/2	1/2	1/2	1/2	1/2	1/2	
48000	7/8	1-1/8	1-1/8	1-1/8	1-1/8	1-1/8	1-1/8	1-1/8	1-3/8	1-3/8	1-1/8	1-3/8	1-3/8	1-5/8	1-5/8	1-3/8	1-5/8	1-5/8	2-1/8	2-1/8	1-5/8	2-1/8	2-1/8	2-1/8	2-1/8	1/2	1/2	1/2	5/8	5/8	5/8	5/8	5/8	
54000	7/8	1-1/8	1-1/8	1-1/8	1-3/8	1-1/8	1-1/8	1-3/8	1-3/8	1-3/8	1-3/8	1-3/8	1-3/8	1-5/8	1-5/8	1-5/8	1-3/8	1-5/8	2-1/8	2-1/8	2-1/8	2-1/8	2-1/8	2-1/8	2-1/8	1/2	1/2	1/2	5/8	5/8	5/8	5/8	5/8	
60000	7/8	1-1/8	1-1/8	1-1/8	1-3/8	1-1/8	1-1/8	1-3/8	1-3/8	1-3/8	1-3/8	1-3/8	1-3/8	1-5/8	1-5/8	2-1/8	1-5/8	1-5/8	2-1/8	2-1/8	2-1/8	2-1/8	2-1/8	2-1/8	2-1/8	1/2	1/2	1/2	5/8	5/8	5/8	5/8	5/8	
66000	7/8	1-1/8	1-1/8	1-3/8	1-3/8	1-1/8	1-1/8	1-3/8	1-3/8	1-5/8	1-3/8	1-5/8	1-5/8	1-5/8	2-1/8	1-5/8	2-1/8	2-1/8	2-1/8	2-1/8	2-1/8	2-1/8	2-1/8	2-1/8	2-1/8	1/2	1/2	5/8	5/8	5/8	5/8	5/8	5/8	
72000	1-1/8	1-1/8	1/1/8	1-3/8	1-3/8	1-1/8	1-3/8	1-3/8	1-3/8	1-5/8	1-3/8	1-5/8	1-5/8	2-1/8	2-1/8	1-5/8	2-1/8	2-1/8	2-1/8	2-5/8	2-1/8	2-1/8	2-5/8	2-5/8	2-5/8	1/2	1/2	5/8	5/8	5/8	5/8	5/8	5/8	
78000	1-1/8	1-1/8	1-3/8	1-3/8	1-3/8	1-1/8	1-3/8	1-3/8	1-5/8	1-5/8	1-3/8	1-5/8	1-5/8	2-1/8	2-1/8	1-5/8	2-1/8	2-1/8	2-1/8	2-5/8	2-1/8	2-5/8	2-5/8	2-5/8	3-1/8	1/2	1/2	5/8	5/8	5/8	5/8	5/8	5/8	
84000	1-1/8	1-1/8	1-3/8	1-3/8	1-3/8	1-2/8	1-3/8	1-3/8	1-5/8	1-5/8	1-3/8	1-5/8	2-1/8	2-1/8	2-1/8	1-5/8	2-1/8	2-1/8	2-1/8	2-5/8	2-1/8	2-5/8	2-5/8	2-5/8	3-1/8	1/2	5/8	5/8	5/8	5/8	7/8	7/8	7/8	
90000	1-1/8	1-1/8	1-3/8	1-3/8	1-5/8	1-1/8	1-3/8	1-5/8	1-5/8	1-5/8	1-3/8	1-5/8	2-1/8	2-1/8	2-1/8	1-5/8	2-1/8	2-1/8	2-5/8	2-5/8	2-1/8	2-5/8	2-5/8	2-5/8	3-1/8	1/2	5/8	5/8	5/8	5/8	7/8	7/8	7/8	
120000	1-1/8	1-3/8	1-3/8	1-5/8	1-5/8	1-3/8	1-5/8	1-5/8	2-1/8	2-1/8	1-5/8	2-1/8	2-1/8	2-1/8	2-5/8	2-1/8	2-1/8	2-5/8	2-5/8	2-5/8	2-5/8	2-5/8	2-5/8	2-5/8	3-1/8	3-5/8	5/8	5/8	7/8	7/8	7/8	7/8	7/8	
150000	1-3/8	1-3/8	1-5/8	1-5/8	2-1/8	1-3/8	1-5/8	2-1/8	2-1/8	2-1/8	2-1/8	2-1/8	2-1/8	2-5/8	2-5/8	2-1/8	2-5/8	2-5/8	2-5/8	3-1/8	2-5/8	3-1/8	3-1/8	3-5/8	3-5/8	5/8	7/8	7/8	7/8	7/8	7/8	7/8	7/8	
180000	1-3/8	1-5/8	1-5/8	2-1/8	2-1/8	1-5/8	2-1/8	2-1/8	2-1/8	2-1/8	2-1/8	2-1/8	2-5/8	2-5/8	2-5/8	2-1/8	2-5/8	2-5/8	3-1/8	3-1/8	2-5/8	3-1/8	3-5/8	3-5/8	4-1/8	5/8	7/8	7/8	7/8	7/8	7/8	7/8	7/8	
210000	1-3/8	1-5/8	2-1/8	2-1/8	2-1/8	1-5/8	2-1/8	2-1/8	2-1/8	2-5/8	2-1/8	2-5/8	2-5/8	2-5/8	3-1/8	2-5/8	2-5/8	3-1/8	3-1/8	3-5/8	3-1/8	3-1/8	3-5/8	3-5/8	4-1/8	5/8	7/8	7/8	7/8	7/8	7/8	7/8	7/8	
240000	1-5/8	1-5/8	2-1/8	2-1/8	2-1/8	1-5/8	2-1/8	2-1/8	2-1/8	2-5/8	2-1/8	2-5/8	2-5/8	2-5/8	3-1/8	2-5/8	3-1/8	3-1/8	3-1/8	3-5/8	3-1/8	3-5/8	3-5/8	4-1/8	4-1/8	7/8	7/8	7/8	7/8	7/8	1-1/8	1-1/8	1-1/8	
300000	1-5/8	2-1/8	2-1/8	2-1/8	2-5/8	2-1/8	2-1/8	2-5/8	2-5/8	2-5/8	2-1/8	2-5/8	3-1/8	3-1/8	3-1/8	2-5/8	3-1/8	3-5/8	3-3/8	4-1/8	3-1/8	3-5/8	4-1/8	4-1/8	5-1/8	7/8	7/8	7/8	1-1/8	1-1/8	1-1/8	1-1/8	1-1/8	
360000	1-5/8	2-1/8	2-1/8	2-1/8	2-5/8	2-1/8	2-5/8	2-5/8	2-5/8	3-1/8	2-5/8	2-5/8	3-1/8	3-1/8	3-5/8	3-1/8	3-1/8	3-5/8	3-5/8	4-1/8	3-5/8	4-1/8	5-1/8	5-1/8	5-1/8	7/8	7/8	1-1/8	1-1/8	1-1/8	1-1/8	1-1/8	1-1/8	
480000	2-1/8	2-1/8	2-5/8	2-5/8	2-5/8	2-1/8	2-5/8	2-5/8	3-1/8	3-1/8	2-5/8	3-1/8	3-5/8	3-5/8	3-5/8	3-1/8	3-5/8	4-1/8	4-1/8	5-1/8	4-1/8	4-1/8	5-1/8	5-1/8	6-1/8	7/8	1-1/8	1-1/8	1-1/8	1-1/8	1-3/8	1-3/8	1-3/8	
600000	2-1/8	2-1/8	2-5/8	2-5/8	3-1/8	2-5/8	2-5/8	3-1/8	3-1/8	3-5/8	3-5/8	3-5/8	3-5/8	4-1/8	3-5/8	4-1/8	4-1/8	5-1/8	5-1/8	5-1/8	4-1/8	4-1/8	5-1/8	6-1/8	6-1/8	1-1/8	1-1/8	1-1/8	1-3/8	1-3/8	1-3/8	1-3/8	1-3/8	

- Notes:**
- Line sizes are calculated at 100% system capacity
 - Suction lines sized based on a maximum total pressure drop equivalent to 2°F
 - Sizing is based on 65°F return gas at compressor with a liquid temperature of 100°F
 - Line sizes are O.D. using type 'L' copper tubing.
 - Follow proper piping practices to ensure proper oil return, including proper slopes, traps and supporting.
 - Double suction risers might be necessary with cylinder unloading. Consult factory if unsure.

REFRIGERANT LINE SIZING CHARTS

R448A

Capacity BTU/Hr.	R448A Suction Line Size from Evaporator to Compressor R448A																									Liquid Line Size						
	+45°F SST Equivalent Length					+25°F SST Equivalent Length					+0°F SST Equivalent Length					-20°F SST Equivalent Length					-40°F SST Equivalent Length					Receiver to TXV Equivalent Length						
	25'	50'	75'	100'	150'	25'	50'	75'	100'	150'	25'	50'	75'	100'	150'	25'	50'	75'	100'	150'	25'	50'	75'	100'	150'	25'	50'	75'	100'	150'		
2000	3/8	3/8	3/8	3/8	3/8	3/8	3/8	3/8	1/2	1/2	1/2	1/2	1/2	1/2	1/2	1/2	1/2	5/8	5/8	5/8	5/8	5/8	5/8	5/8	7/8	7/8	3/8	3/8	3/8	3/8	3/8	
3000	3/8	1/2	1/2	1/2	1/2	1/2	1/2	1/2	1/2	1/2	1/2	1/2	1/2	5/8	5/8	1/2	5/8	5/8	5/8	7/8	5/8	7/8	7/8	7/8	7/8	7/8	7/8	3/8	3/8	3/8	3/8	3/8
4000	1/2	1/2	1/2	1/2	1/2	1/2	1/2	1/2	1/2	5/8	1/2	5/8	5/8	5/8	7/8	7/8	5/8	7/8	7/8	7/8	7/8	7/8	7/8	7/8	7/8	1-1/8	3/8	3/8	3/8	3/8	3/8	
6000	1/2	1/2	1/2	1/2	5/8	1/2	1/2	5/8	5/8	5/8	5/8	5/8	7/8	7/8	7/8	5/8	7/8	7/8	7/8	7/8	7/8	7/8	7/8	7/8	1-1/8	1-1/8	1-1/8	3/8	3/8	3/8	3/8	3/8
9000	1/2	1/2	5/8	5/8	5/8	1/2	5/8	5/8	7/8	7/8	5/8	7/8	7/8	7/8	7/8	7/8	7/8	7/8	1-1/8	1-1/8	7/8	1-1/8	1-1/8	1-1/8	1-1/8	1-3/8	3/8	3/8	3/8	3/8	3/8	
12000	1/2	5/8	5/8	5/8	7/8	5/8	5/8	7/8	7/8	7/8	7/8	7/8	7/8	7/8	1-1/8	7/8	1-1/8	1-1/8	1-1/8	1-1/8	7/8	1-1/8	1-1/8	1-1/8	1-1/8	1-3/8	3/8	3/8	3/8	3/8	3/8	
15000	5/8	5/8	7/8	7/8	7/8	5/8	7/8	7/8	7/8	7/8	7/8	7/8	7/8	1-1/8	1-1/8	7/8	1-1/8	1-1/8	1-1/8	1-3/8	1-1/8	1-3/8	1-3/8	1-3/8	1-3/8	1-5/8	3/8	3/8	3/8	3/8	3/8	
18000	5/8	7/8	7/8	7/8	7/8	7/8	7/8	7/8	7/8	1-1/8	7/8	7/8	1-1/8	1-1/8	1-1/8	1-1/8	1-1/8	1-1/8	1-3/8	1-3/8	1-1/8	1-3/8	1-3/8	1-3/8	1-5/8	1-5/8	3/8	3/8	3/8	3/8	1/2	
24000	5/8	7/8	7/8	7/8	7/8	7/8	7/8	7/8	1-1/8	1-1/8	7/8	1-1/8	1-1/8	1-1/8	1-3/8	1-1/8	1-3/8	1-3/8	1-3/8	1-5/8	1-3/8	1-3/8	1-3/8	1-5/8	1-5/8	2-1/8	3/8	3/8	3/8	3/8	1/2	
30000	7/8	7/8	7/8	7/8	1-1/8	7/8	7/8	1-1/8	1-1/8	1-1/8	1-1/8	1-1/8	1-1/8	1-3/8	1-3/8	1-1/8	1-3/8	1-3/8	1-5/8	1-5/8	1-3/8	1-5/8	1-5/8	2-1/8	2-1/8	2-1/8	3/8	3/8	1/2	1/2	1/2	
36000	7/8	7/8	7/8	1-1/8	1-1/8	7/8	1-1/8	1-1/8	1-1/8	1-3/8	1-1/8	1-1/8	1-3/8	1-3/8	1-3/8	1-3/8	1-3/8	1-3/8	1-5/8	1-5/8	2-1/8	1-5/8	1-5/8	2-1/8	2-1/8	2-1/8	3/8	1/2	1/2	1/2	1/2	
48000	7/8	1-1/8	1-1/8	1-1/8	1-1/8	1-1/8	1-1/8	1-1/8	1-3/8	1-3/8	1-1/8	1-3/8	1-3/8	1-5/8	1-5/8	1-3/8	1-5/8	1-5/8	2-1/8	2-1/8	1-5/8	2-1/8	2-1/8	2-1/8	2-1/8	2-5/8	3/8	1/2	1/2	1/2	5/8	
54000	7/8	1-1/8	1-1/8	1-1/8	1-3/8	1-1/8	1-1/8	1-3/8	1-3/8	1-3/8	1-1/8	1-3/8	1-5/8	1-5/8	1-5/8	1-3/8	1-5/8	2-1/8	2-1/8	2-1/8	1-5/8	2-1/8	2-1/8	2-1/8	2-5/8	1/2	1/2	1/2	1/2	5/8		
60000	7/8	1-1/8	1-1/8	1-1/8	1-3/8	1-1/8	1-1/8	1-3/8	1-3/8	1-3/8	1-3/8	1-3/8	1-5/8	1-5/8	2-1/8	1-3/8	1-5/8	2-1/8	2-1/8	2-1/8	2-1/8	2-1/8	2-1/8	2-5/8	2-5/8	1/2	1/2	1/2	5/8	5/8		
66000	7/8	1-1/8	1-1/8	1-3/8	1-3/8	1-1/8	1-3/8	1-3/8	1-3/8	1-5/8	1-3/8	1-3/8	1-5/8	1-5/8	2-1/8	1-5/8	2-1/8	2-1/8	2-1/8	2-1/8	2-1/8	2-1/8	2-1/8	2-5/8	2-5/8	1/2	1/2	5/8	5/8	5/8		
72000	1-1/8	1-1/8	1-1/8	1-3/8	1-3/8	1-1/8	1-3/8	1-3/8	1-3/8	1-5/8	1-3/8	1-5/8	1-5/8	1-5/8	2-1/8	1-5/8	2-1/8	2-1/8	2-1/8	2-1/8	2-1/8	2-1/8	2-1/8	2-5/8	2-5/8	1/2	1/2	5/8	5/8	5/8		
78000	7/8	1-1/8	1-3/8	1-3/8	1-3/8	1-1/8	1-3/8	1-3/8	1-5/8	1-5/8	1-3/8	1-5/8	1-5/8	2-1/8	2-1/8	1-5/8	2-1/8	2-1/8	2-1/8	2-5/8	2-1/8	2-1/8	2-5/8	2-5/8	3-1/8	1/2	1/2	5/8	5/8	5/8		
84000	1-1/8	1-1/8	1-3/8	1-3/8	1-3/8	1-1/8	1-3/8	1-3/8	1-5/8	1-5/8	1-3/8	1-5/8	1-5/8	2-1/8	2-1/8	1-5/8	2-1/8	2-1/8	2-1/8	2-5/8	2-1/8	2-5/8	2-5/8	2-5/8	3-1/8	1/2	5/8	5/8	5/8	7/8		
90000	1-1/8	1-1/8	1-3/8	1-3/8	1-3/8	1-1/8	1-3/8	1-3/8	1-5/8	1-5/8	1-3/8	1-5/8	2-1/8	2-1/8	2-1/8	1-5/8	2-1/8	2-1/8	2-1/8	2-5/8	2-1/8	2-5/8	2-5/8	2-5/8	3-1/8	5/8	5/8	5/8	5/8	7/8		
120000	1-1/8	1-3/8	1-3/8	1-5/8	1-5/8	1-3/8	1-5/8	1-5/8	1-5/8	2-1/8	1-5/8	2-1/8	2-1/8	2-1/8	2-1/8	2-1/8	2-1/8	2-5/8	2-5/8	2-5/8	2-5/8	2-5/8	2-5/8	3-1/8	3-1/8	5/8	5/8	5/8	7/8	7/8		
150000	1-3/8	1-3/8	1-5/8	1-5/8	2-1/8	1-3/8	1-5/8	2-1/8	2-1/8	2-1/8	1-5/8	2-1/8	2-1/8	2-1/8	2-5/8	2-1/8	2-5/8	2-5/8	2-5/8	3-1/8	2-5/8	3-1/8	3-1/8	3-1/8	3-5/8	5/8	7/8	7/8	7/8	7/8		
180000	1-3/8	1-5/8	1-5/8	1-5/8	2-1/8	1-5/8	2-1/8	2-1/8	2-1/8	2-1/8	2-1/8	2-1/8	2-5/8	2-5/8	2-5/8	2-1/8	2-5/8	2-5/8	3-1/8	3-1/8	2-5/8	3-1/8	3-1/8	3-5/8	3-5/8	5/8	7/8	7/8	7/8	7/8		
210000	1-3/8	1-5/8	1-5/8	2-1/8	2-1/8	1-5/8	2-1/8	2-1/8	2-1/8	2-5/8	2-1/8	2-1/8	2-5/8	2-5/8	2-5/8	2-5/8	2-5/8	3-1/8	3-1/8	3-1/8	3-1/8	3-1/8	3-1/8	3-5/8	4-1/8	5/8	7/8	7/8	7/8	7/8		
240000	1-5/8	1-5/8	2-1/8	2-1/8	2-1/8	1-5/8	2-1/8	2-1/8	2-1/8	2-5/8	2-1/8	2-5/8	2-5/8	2-5/8	3-1/8	2-5/8	3-1/8	3-1/8	3-1/8	3-5/8	3-1/8	3-5/8	3-5/8	4-1/8	4-1/8	7/8	7/8	7/8	7/8	1-1/8		
300000	1-5/8	2-1/8	2-1/8	2-1/8	2-1/8	2-1/8	2-1/8	2-5/8	2-5/8	2-5/8	2-1/8	2-5/8	2-5/8	3-1/8	3-1/8	2-5/8	3-1/8	3-1/8	3-5/8	3-5/8	3-1/8	3-5/8	1-1/8	4-1/8	5-1/8	7/8	7/8	7/8	1-1/8	1-1/8		
360000	1-5/8	2-1/8	2-1/8	2-1/8	2-5/8	2-1/8	2-1/8	2-5/8	2-5/8	2-5/8	2-5/8	2-5/8	3-1/8	3-1/8	3-5/8	3-1/8	3-1/8	3-5/8	3-5/8	4-1/8	3-5/8	4-1/8	4-1/8	5-1/8	5-1/8	7/8	1-1/8	1-1/8	1-1/8	1-1/8		
480000	2-1/8	2-1/8	2-5/8	2-5/8	2-5/8	2-1/8	2-5/8	2-5/8	3-1/8	3-1/8	2-5/8	3-1/8	3-1/8	3-5/8	3-5/8	3-1/8	3-5/8	4-1/8	4-1/8	5-1/8	3-5/8	5-1/8	5-1/8	5-1/8	6-1/8	7/8	1-1/8	1-1/8	1-3/8	1-3/8		
600000	2-5/8	2-5/8	3-1/8	3-1/8	3-5/8	2-5/8	2-5/8	3-1/8	3-1/8	3-5/8	3-1/8	3-1/8	3-5/8	3-5/8	4-1/8	3-5/8	4-1/8	4-1/8	5-1/8	4-1/8	5-1/8	5-1/8	5-1/8	6-1/8	6-1/8	1-1/8	1-1/8	1-3/8	1-3/8	1-3/8		

- Notes:**
- Line sizes are calculated at 100% system capacity
 - Suction lines sized based on a maximum total pressure drop equivalent to 2°F
 - Sizing is based on 65°F return gas at compressor with a liquid temperature of 100°F
 - Line sizes are O.D. using type 'L' copper tubing.
 - Follow proper piping practices to ensure proper oil return, including proper slopes, traps and supporting.
 - Double suction risers might be necessary with cylinder unloading. Consult factory if unsure.

REFRIGERANT LINE SIZING CHARTS

R22

Capacity BTU/Hr.	R22 Suction Line Size from Evaporator to Compressor R22																									Liquid Line Size				
	+45°F SST Equivalent Length					+25°F SST Equivalent Length					+0°F SST Equivalent Length					-20°F SST Equivalent Length					-40°F SST Equivalent Length					Receiver to TXV Equivalent Length				
	25'	50'	75'	100'	150'	25'	50'	75'	100'	150'	25'	50'	75'	100'	150'	25'	50'	75'	100'	150'	25'	50'	75'	100'	150'	25'	50'	75'	100'	150'
2000	3/8	3/8	3/8	3/8	3/8	3/8	3/8	3/8	1/2	1/2	3/8	1/2	1/2	1/2	1/2	1/2	1/2	1/2	5/8	5/8	1/2	5/8	5/8	7/8	3/8	3/8	3/8	3/8	3/8	
3000	3/8	3/8	1/2	1/2	1/2	3/8	1/2	1/2	1/2	1/2	1/2	1/2	1/2	5/8	5/8	1/2	5/8	5/8	5/8	7/8	5/8	5/8	7/8	7/8	3/8	3/8	3/8	3/8	3/8	
4000	1/2	1/2	1/2	1/2	1/2	1/2	1/2	1/2	1/2	5/8	1/2	1/2	5/8	5/8	5/8	5/8	5/8	7/8	7/8	7/8	5/8	7/8	7/8	7/8	3/8	3/8	3/8	3/8	3/8	
6000	1/2	1/2	1/2	1/2	5/8	1/2	1/2	5/8	5/8	5/8	1/2	5/8	5/8	7/8	7/8	5/8	7/8	7/8	7/8	7/8	7/8	7/8	1-1/8	1-1/8	3/8	3/8	3/8	3/8	3/8	
9000	1/2	1/2	1/2	5/8	5/8	1/2	5/8	5/8	7/8	7/8	5/8	7/8	7/8	7/8	7/8	7/8	7/8	7/8	1-1/8	1-1/8	7/8	1-1/8	1-1/8	1-1/8	3/8	3/8	3/8	3/8	3/8	
12000	1/2	5/8	5/8	5/8	7/8	5/8	5/8	7/8	7/8	7/8	7/8	7/8	7/8	1-1/8	7/8	7/8	1-1/8	1-1/8	1-1/8	1-1/8	1-1/8	1-1/8	1-1/8	1-3/8	3/8	3/8	3/8	3/8	3/8	
15000	5/8	5/8	7/8	7/8	7/8	5/8	7/8	7/8	7/8	7/8	7/8	7/8	7/8	1-1/8	7/8	1-1/8	1-1/8	1-1/8	1-3/8	1-1/8	1-1/8	1-3/8	1-3/8	3/8	3/8	3/8	3/8	3/8		
18000	5/8	5/8	7/8	7/8	7/8	5/8	7/8	7/8	7/8	7/8	7/8	7/8	1-1/8	1-1/8	7/8	1-1/8	1-1/8	1-1/8	1-3/8	1-1/8	1-3/8	1-3/8	1-3/8	3/8	3/8	3/8	3/8	3/8		
24000	5/8	7/8	7/8	7/8	7/8	7/8	7/8	7/8	1-1/8	1-1/8	7/8	1-1/8	1-1/8	1-1/8	1-3/8	1-1/8	1-1/8	1-3/8	1-3/8	1-3/8	1-3/8	1-3/8	1-3/8	3/8	3/8	2/8	1/2	1/2		
30000	7/8	7/8	7/8	7/8	1-1/8	7/8	7/8	1-1/8	1-1/8	1-1/8	1-1/8	1-1/8	1-1/8	1-3/8	1-3/8	1-1/8	1-3/8	1-3/8	1-3/8	1-5/8	1-3/8	1-5/8	1-5/8	1/2	1/2	1/2	1/2	1/2		
36000	7/8	7/8	7/8	1-1/8	1-1/8	7/8	1-1/8	1-1/8	1-1/8	1-1/8	1-1/8	1-1/8	1-3/8	1-3/8	1-1/8	1-3/8	1-3/8	1-5/8	1-5/8	1-3/8	1-5/8	1-5/8	2-1/8	1/2	1/2	1/2	1/2	1/2		
48000	7/8	1-1/8	1-1/8	1-1/8	1-1/8	7/8	1-1/8	1-1/8	1-3/8	1-3/8	1-1/8	1-3/8	1-3/8	1-5/8	1-3/8	1-5/8	1-5/8	1-5/8	2-1/8	1-3/8	1-5/8	2-1/8	2-1/8	1/2	1/2	1/2	1/2	5/8		
54000	7/8	1-1/8	1-1/8	1-1/8	1-3/8	1-1/8	1-1/8	1-1/8	1-3/8	1-3/8	1-1/8	1-3/8	1-3/8	1-5/8	1-5/8	1-3/8	1-3/8	1-5/8	2-1/8	2-1/8	1-5/8	2-1/8	2-1/8	1/2	1/2	1/2	1/2	5/8		
60000	7/8	1-1/8	1-1/8	1-1/8	1-3/8	1-1/8	1-1/8	1-3/8	1-3/8	1-3/8	1-1/8	1-3/8	1-5/8	1-5/8	1-5/8	1-3/8	1-5/8	2-1/8	2-1/8	2-1/8	1-5/8	2-1/8	2-1/8	1/2	1/2	1/2	5/8	5/8		
66000	1-1/8	1-1/8	1-1/8	1-1/8	1-3/8	1-1/8	1-1/8	1-3/8	1-3/8	1-5/8	1-3/8	1-3/8	1-5/8	1-5/8	2-1/8	1-3/8	1-5/8	2-1/8	2-1/8	2-1/8	2-1/8	2-1/8	2-5/8	1/2	1/2	1/2	5/8	5/8		
72000	1-1/8	1-1/8	1-1/8	1-3/8	1-3/8	1-1/8	1-3/8	1-3/8	1-3/8	1-5/8	1-3/8	1-3/8	1-5/8	1-5/8	2-1/8	1-5/8	1-5/8	2-1/8	2-1/8	2-1/8	2-1/8	2-1/8	2-5/8	1/2	1/2	5/8	5/8	5/8		
78000	1-1/8	1-1/8	1-3/8	1-3/8	1-3/8	1-1/8	1-3/8	1-3/8	1-3/8	1-5/8	1-3/8	1-5/8	1-5/8	1-5/8	2-1/8	1-5/8	2-1/8	2-1/8	2-1/8	2-1/8	2-1/8	2-1/8	2-5/8	1/2	1/2	5/8	5/8	5/8		
84000	1-1/8	1-1/8	1-3/8	1-3/8	1-3/8	1-1/8	1-3/8	1-3/8	1-5/8	1-5/8	1-3/8	1-5/8	1-5/8	2-1/8	2-1/8	1-5/8	2-1/8	2-1/8	2-1/8	2-1/8	2-1/8	2-1/8	2-5/8	1/2	5/8	5/8	5/8	5/8		
90000	1-1/8	1-1/8	1-3/8	1-3/8	1-3/8	1-1/8	1-3/8	1-3/8	1-5/8	1-5/8	1-3/8	1-5/8	1-5/8	2-1/8	2-1/8	1-5/8	2-1/8	2-1/8	2-1/8	2-5/8	2-1/8	2-1/8	2-5/8	1/2	5/8	5/8	5/8	7/8		
120000	1-1/8	1-3/8	1-3/8	1-5/8	1-5/8	1-3/8	1-5/8	1-5/8	1-5/8	2-1/8	1-5/8	2-1/8	2-1/8	2-1/8	2-1/8	2-1/8	2-1/8	2-1/8	2-5/8	2-5/8	2-1/8	2-5/8	3-1/8	1/2	5/8	5/8	7/8	7/8		
150000	1-3/8	1-3/8	1-5/8	1-5/8	2-1/8	1-3/8	1-5/8	2-1/8	2-1/8	2-1/8	1-5/8	2-1/8	2-1/8	2-1/8	2-5/8	2-1/8	2-1/8	2-5/8	2-5/8	2-5/8	2-5/8	2-5/8	3-1/8	5/8	5/8	7/8	7/8	7/8		
180000	1-3/8	1-5/8	1-5/8	1-5/8	2-1/8	1-5/8	1-5/8	2-1/8	2-1/8	2-1/8	2-1/8	2-1/8	2-1/8	2-5/8	2-5/8	2-1/8	2-5/8	2-5/8	2-5/8	3-1/8	2-5/8	3-1/8	3-1/8	5/8	7/8	7/8	7/8	7/8		
210000	1-3/8	1-5/8	1-5/8	2-1/8	2-1/8	1-5/8	2-1/8	2-1/8	2-1/8	2-1/8	2-1/8	2-1/8	2-5/8	2-5/8	2-5/8	2-1/8	2-5/8	2-5/8	3-1/8	3-1/8	2-5/8	3-1/8	3-1/8	5/8	7/8	7/8	7/8	7/8		
240000	1-3/8	1-5/8	2-1/8	2-1/8	2-1/8	1-5/8	2-1/8	2-1/8	2-1/8	2-5/8	2-1/8	2-5/8	2-5/8	3-1/8	2-5/8	2-5/8	3-1/8	3-1/8	3-5/8	2-5/8	3-1/8	3-5/8	3-5/8	7/8	7/8	7/8	7/8	1-1/8		
300000	1-5/8	2-1/8	2-1/8	2-1/8	2-1/8	2-1/8	2-1/8	2-1/8	2-5/8	2-5/8	2-1/8	2-5/8	2-5/8	3-1/8	3-1/8	2-5/8	3-1/8	3-1/8	3-5/8	3-1/8	3-5/8	3-5/8	4-1/8	7/8	7/8	7/8	1-1/8	1-1/8		
360000	1-5/8	2-1/8	2-1/8	2-1/8	2-5/8	2-1/8	2-1/8	2-5/8	2-5/8	2-5/8	2-5/8	2-5/8	3-1/8	3-1/8	3-1/8	2-5/8	3-1/8	3-5/8	3-5/8	4-1/8	3-1/8	3-5/8	4-1/8	7/8	7/8	1-1/8	1-1/8	1-1/8		
480000	2-1/8	2-1/8	2-5/8	2-5/8	2-5/8	2-1/8	2-5/8	2-5/8	3-1/8	3-1/8	2-5/8	3-1/8	3-1/8	3-5/8	3-5/8	3-1/8	3-5/8	3-5/8	4-1/8	4-1/8	3-5/8	4-1/8	5-1/8	7/8	1-1/8	1-1/8	1-1/8	1-3/8		
600000	2-1/8	2-5/8	2/5/8	2-5/8	3-1/8	2-5/8	2-5/8	3-1/8	3-1/8	3-1/8	2-5/8	3-1/8	3-5/8	3-5/8	4-1/8	3-1/8	3-5/8	4-1/8	4-1/8	5-1/8	4-1/8	5-1/8	6-1/8	1-1/8	1-1/8	1-1/8	1-3/8	1-3/8		

Notes:

- Line sizes are calculated at 100% system capacity
- Suction lines sized based on a maximum total pressure drop equivalent to 2°F
- Sizing is based on 65°F return gas at compressor with a liquid temperature of 100°F
- Line sizes are O.D. using type 'L' copper tubing.
- Follow proper piping practices to ensure proper oil return, including proper slopes, traps and supporting.
- Double suction risers might be necessary with cylinder unloading. Consult factory if unsure.

Appendix C:

Equipment Start-Up Sheets

Company/Location:

Condensing Unit Model:		Condensing Unit Serial:	
Evaporator Unit Model:		Evaporator Unit Serial:	
Compressor model number		Compressor serial number	
Original System start-up date:		Today's Date:	
Refrigerant Type :		Total Charge:	
System evacuation; # of times:		Final micron:	
Expansion valve - Model Number:			

**ALL READINGS SHOULD BE MADE WITH PROPERLY CALIBRATED MEASURING EQUIPMENT
ALL REQUIRED INFORMATION MUST BE SUPPLIED FOR AN ACCURATE DIAGNOSIS**

System Conditions

(Record after system has been running for a minimum of 4 hours or when lowest possible temperature has been reached)

Designed Box Temperature:		°F	
Operating Box Temperature:		°F	
Thermostat Setting: Cut- In		°F	
Thermostat Setting: Cut-Out		°F	
Thermostat Differential Setting:		°F	
Ambient Temperature Around Box Exterior:		°F	Show different temperatures if required and note on drawing.
Ambient Temperature @ Condensing Unit:		°F	
Discharge Pressure:		PSIG	
Discharge Temperature @ Service Valve:		°F	6" away from discharge valve.
Suction Pressure @ Service Valve:		PSIG	
Suction Line Temperature @ Service Valve:		°F	6" away from suction service valve.
Condensate Line Temperature:		°F	Line between the condenser and receiver.
Liquid Line Temp Leaving Receiver:		°F	
Liquid Line Temp Leaving Condensing Unit:		°F	
Liquid Line Temp Entering TXV:		°F	
Suction Pressure Leaving Evaporator:		PSIG	If available by schrader access.
Suction Line Temp @ TXV Bulb:		°F	
Evaporator Superheat:		°F	
Compressor Superheat:		°F	
CPR Setting:		PSIG	If applicable.
Pressure upstream of CPR:		PSIG	If applicable.
Pressure downstream of CPR:		PSIG	If applicable.
Oil Pressure:		PSIG	
Oil Level in Compressor Sightglass :		1/4, 1/2, 3/4	During refrigeration.
(Also, make note if bubbles are seen)		1/4, 1/2, 3/4	During pump down.
		1/4, 1/2, 3/4	During start-up after defrost.
Air Temperature Entering Evaporator:		°F	
Supply Air Temperature Leaving Evaporator:		°F	

Water Cooled Condenser

GPM:	<input type="text"/>	Water Inlet:	<input type="text"/>	Verify Inlet / Outlet Water Connection:	<input type="checkbox"/>
PSIG:	<input type="text"/>	Water Outlet:	<input type="text"/>		
Pres-Drop:	<input type="text"/>	Closed Loop:	<input type="text"/>		
Water Valve Size:	<input type="text"/>	City Water:	<input type="text"/>		
Water Valve Model:	<input type="text"/>				

Electrical Data (Record while system is running at conditions on page one (C1))

Condensing Unit

Condensing unit electrical:	<input type="text"/>	Volts	<input type="text"/>	Phase	<input type="text"/>	HZ
Voltage at compressor terminals:	<input type="text"/>	L1-L2	<input type="text"/>	L2-L3	<input type="text"/>	L1-L3
Amperage at compressor:	<input type="text"/>	L1	<input type="text"/>	L2	<input type="text"/>	L3

Evaporator Unit

Evaporator unit electrical:	<input type="text"/>	Volts	<input type="text"/>	Phase	<input type="text"/>	HZ
Voltage at motor terminals:	<input type="text"/>	L1-L2	<input type="text"/>	L2-L3	<input type="text"/>	L1-L3
Amperage at motor:	<input type="text"/>	L1	<input type="text"/>	L2	<input type="text"/>	L3

Evaporator Defrost Settings

Defrost Settings - Number per day	<input type="text"/>	
Defrost Termination :	<input type="text"/>	°F
Fan Delay Setting:	<input type="text"/>	°F

SYSTEM LAYOUT

In the space below, provide piping schematic showing details on pipe size, line run length and P-trap locations

Suction Line Size OD : Liquid Line Size OD: Suction Riser Size OD:

EQUIPMENT AND BOX LAYOUT

In the space below, please provide sketch showing box location, unit cooler location, condensing unit location complete with accurate dimensions.

A complete layout is required to visualize the job location and equipment setup.

Outside Box Dimensions (Feet) :	<input type="text"/>	Length	<input type="text"/>	Width	<input type="text"/>	Height
Box Wall Thickness (Inches) :	<input type="text"/>	Inches				
Glass Door Dimensions (Inches) :	<input type="text"/>	Length	<input type="text"/>	Width	<input type="text"/>	Height
Glass Door Construction :	<input type="text"/>					
Number of Glass Doors :	<input type="text"/>					

BOX LOADING DETAIL

Room Heat Load from Motors or Machinery: BTUH or Watts (Circle One) Lighting

Description of any and all objects inside the box (required for product load) :

MISCELLANEOUS

Describe (in detail) frost pattern on distributor feeds:

Describe (in detail) frost pattern evaporator coil surface:

Is the TXV Bulb Insulated ?

<input type="checkbox"/>	Yes / No
--------------------------	----------

Describe location of TXV Bulb :
(vertical or horizontal)

Is the Suction Line Insulated ?

<input type="checkbox"/>	Yes / No
--------------------------	----------

Please make note of any other items that may have bearing on system performance and box temperature below:

NOTES

NOTES

PRODUCT SUPPORT RESOURCES

FOR SMALL CONDENSING UNITS (TEH, TEZ, TES, TQH, TQZ)

 <p>PRODUCT SUPPORT</p>	<p><i>web:</i> www.t-rp.com/support <i>email:</i> smcu@t-rp.com <i>call:</i> 1-844-893-3222 x521</p>
--	---

FOR MEDIUM AND LARGE CONDENSING UNITS (TMS/TMD, TVS/TVD)

 <p>PRODUCT SUPPORT</p>	<p><i>web:</i> www.t-rp.com/support <i>email:</i> mdcu_lgcu@t-rp.com <i>call:</i> 1-844-893-3222 x522</p>
--	---

FOR REMOTE & WATER COOLED CONDENSING UNITS (R, TX, W)

 <p>PRODUCT SUPPORT</p>	<p><i>web:</i> www.t-rp.com/support <i>email:</i> rcu-wccu@t-rp.com <i>call:</i> 1-844-893-3222 x523</p>
--	---

PRODUCT SUPPORT RESOURCES



TROUBLESHOOTING

*email: troubleshooting@t-rp.com
call: 1-844-893-3222 x529*



SERVICE PARTS

*web: www.t-rp.com/parts
email: parts@t-rp.com
call: 1-844-893-3222 x504*



WARRANTY

*web: www.t-rp.com/warranty
email: warranty@t-rp.com
call: 1-844-893-3222 x507*



ORDERS

*email: orders@t-rp.com
call: 1-844-893-3222 x501*



SHIPPING

*email: shipping@t-rp.com
call: 1-844-893-3222 x503*

“AS BUILT” SERVICE PARTS LIST

Service Parts List
Label
To Be Attached
HERE



Trenton Refrigeration
Brantford, ON • Longview, TX
1-800-463-9517 info@t-rp.com www.t-rp.com

