

Construction methods of embankments on soft soils

The most appropriate construction method to be used in a given project is associated with factors such as geotechnical characteristics of deposits, use of the area, construction deadlines and costs involved. Figure 1.1 presents some construction methods of embankments on soft soils. Some methods contemplate settlement control and others stability control, but most methods contemplate both issues. In the case of very soft soils, it is common to use geosynthetic reinforcement associated with most of the alternatives presented in Figure 1.1.

Time constraints may render inadequate techniques such as conventional embankments (Figure 1.1A,B,C,D,M) or embankments over vertical drains (Figure 1.1K,L), favoring embankments on pile-like elements (Figure 1.1F,G,H) or lightweight fills (Figure 1.1E), which, however, may have higher costs. Removal of soft soil can be used when the layer is not very thick (Figure 1.1I,J) and the transport distances are not considerable. In urban areas, it is difficult to find areas for the disposal of excavated material, considering the environmental issue associated with this disposal.

Space constraints can also prevent the use of berms (Figure 1.1B), particularly in the case of urban areas. The geometry of the embankments and the geotechnical characteristics are highly variable factors and the construction methodology must be analyzed case by case.

I.1 REPLACEMENT OF SOFT SOILS AND DISPLACEMENT FILLS

I.1.1 Replacement of soft soils

Replacement of soft soils is the partial or total removal (Figure 1.1I,J) of these soils using draglines or excavators or the direct placement of landfill to replace the soft soil. This construction method, generally used in deposits with compressible soil thicknesses of up to 4 m, has the advantage of reducing or eliminating settlements and increasing the safety factor against failure. Initially, a working platform is set up to level the terrain, just to allow the access of equipment (Figure 1.2A,B), right after the dredger starts excavating the soft soil, followed by the filling of the excavated space with fill material (Figure 1.2C,D).

Due to the very low support capacity of the top clay layers, these steps must be performed very carefully, and the equipment should be light. For very soft soils, it is noted that service roads suffer continuous settlements, as a result of the overload of

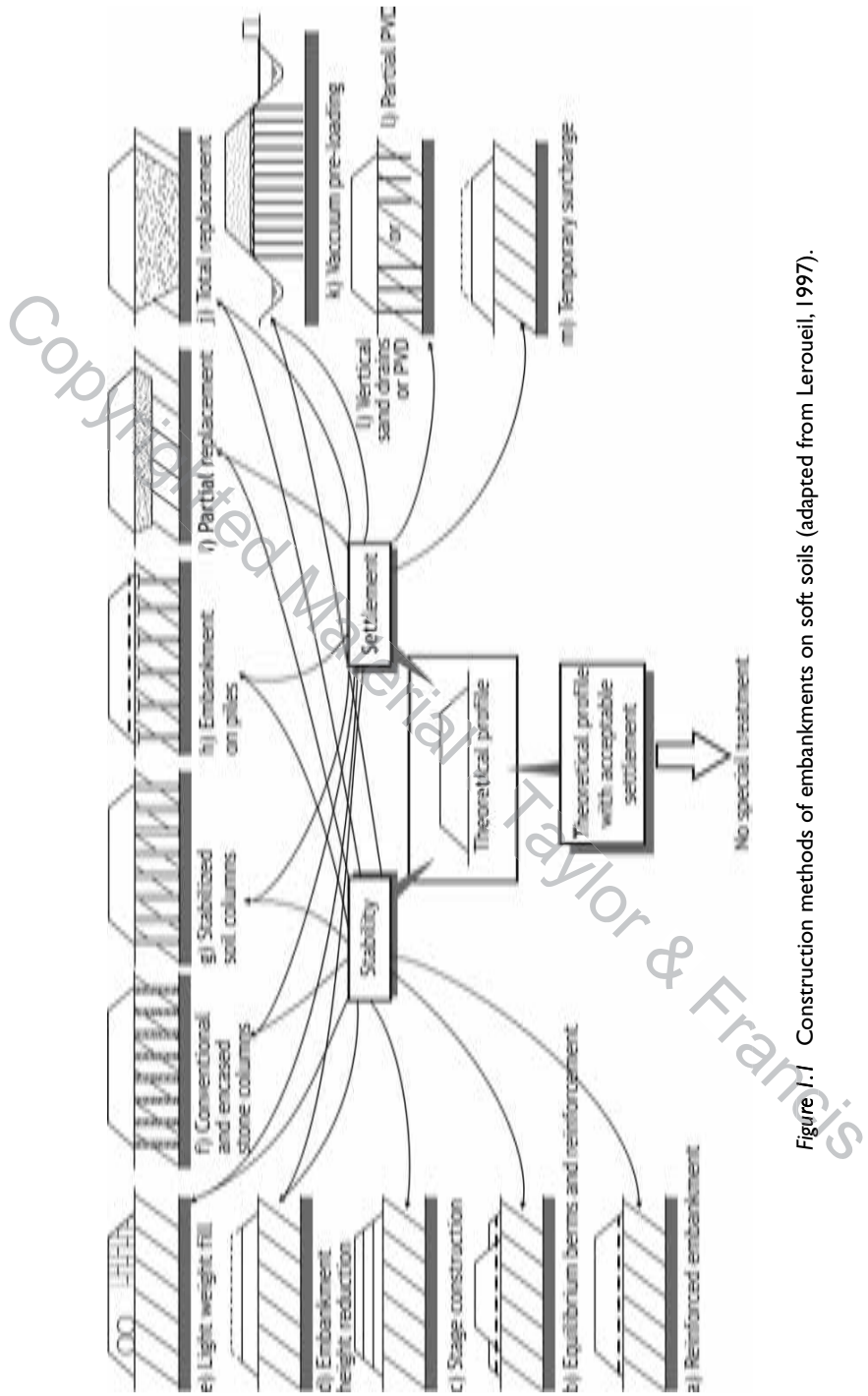

Figure 1.1 Construction methods of embankments on soft soils (adapted from Leroueil, 1997).

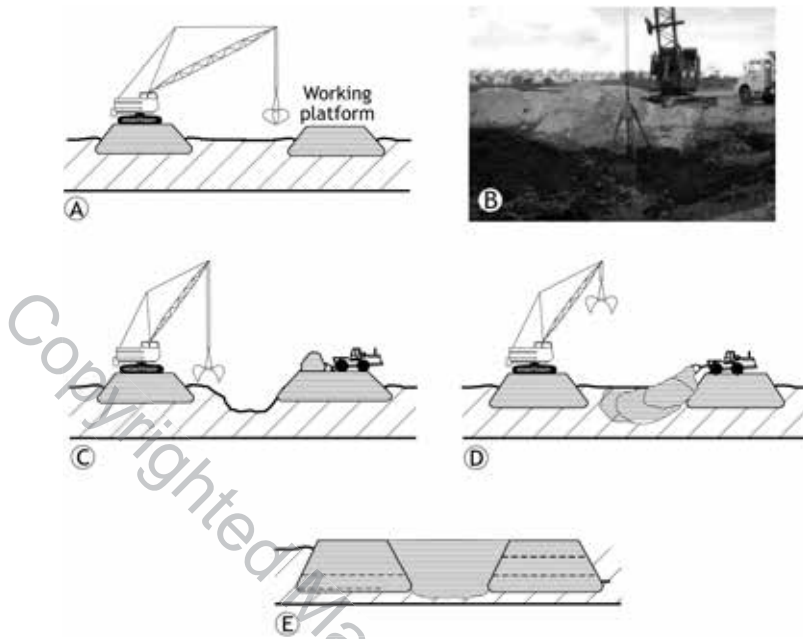

Figure 1.2 Execution schedule for soft soil replacement: (A) and (B) excavation and removal of soft soil; (C) and (D) filling of the hole; (E) replaced soil (final condition).

equipment traffic. Shortly after, the hole is completely filled with fill material (Figure 1.2E), then, it is necessary to verify the thicknesses of the remaining soft clay through boreholes.

1.1.2 Displacement fills

The displacement of soft soils can be accomplished with the embankment's own weight. This technique is called displacement fill, which is the advancement of the frontal part of the embankment, which should be higher than the designed embankment. This will push and expel part of the soft soil layer, causing its rupture and leaving the embedded fill in its place (Zayen et al., 2003). The expulsion is facilitated by the lateral and frontal release of the tip fill, as shown schematically in Figure 1.3. This construction method can be used on the periphery of the area of interest by confining the internal area, allowing the embankment in this area to be constructed with a greater thicknesses.

The thickness of the remaining soft soil must be evaluated through boreholes carried out after the excavation. If there is any remaining soft soil with thickness greater than the desirable, a temporary surcharge shall be applied to eliminate post construction settlements.

One disadvantage of the replacement and displacement methods is the difficulty in quality control, because there is no guarantee that soft material will be removed evenly,

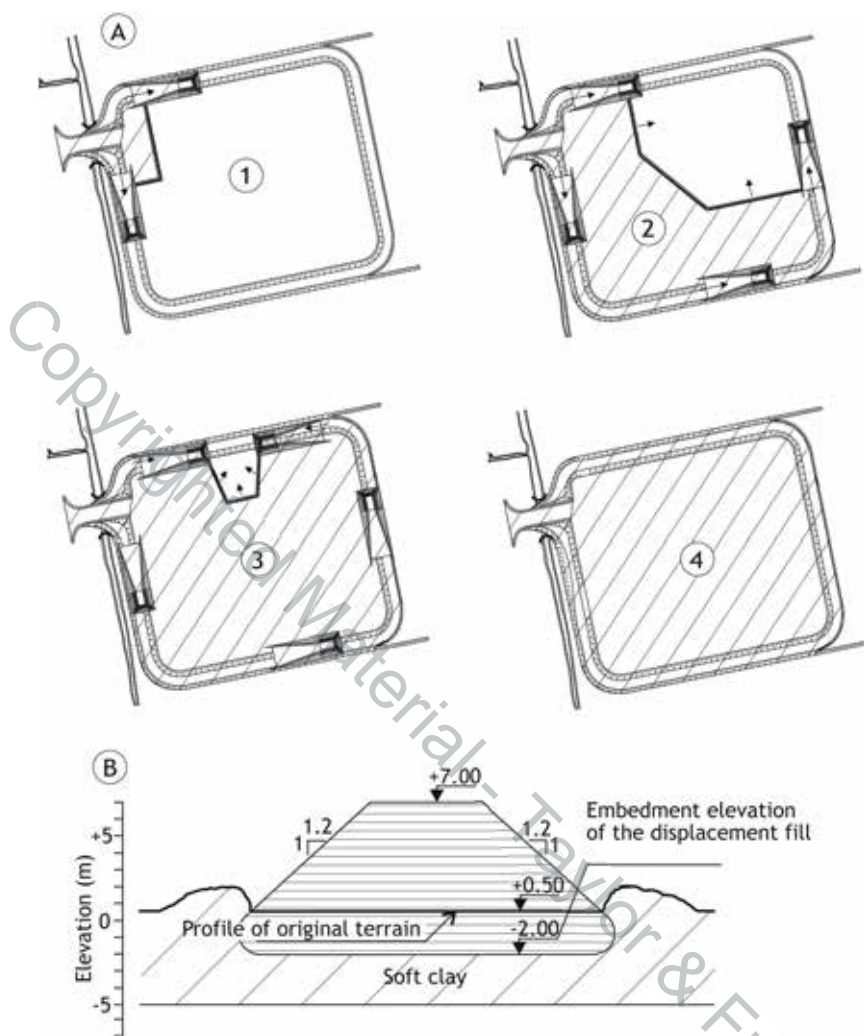

Figure 1.3 Execution methodology of displacement fill at periphery: (A) plan; (B) cross section (Zayen et al., 2003).

which may cause differential settlements. Another disadvantage is associated with high volumes of disposed material and the difficulty of disposal, mainly in urban areas, as it is a material that cannot be reused and in certain cases may even be contaminated.

Working platform

Working platforms, shown in Figure 1.4, are constructed to allow the access of heavy equipment in general for vertical drains installation and pile driving in case of piled embankments for instance. In some cases, the strength of the upper layer is so low that it is necessary to use constructive geotextiles reinforcement, with tensile strength

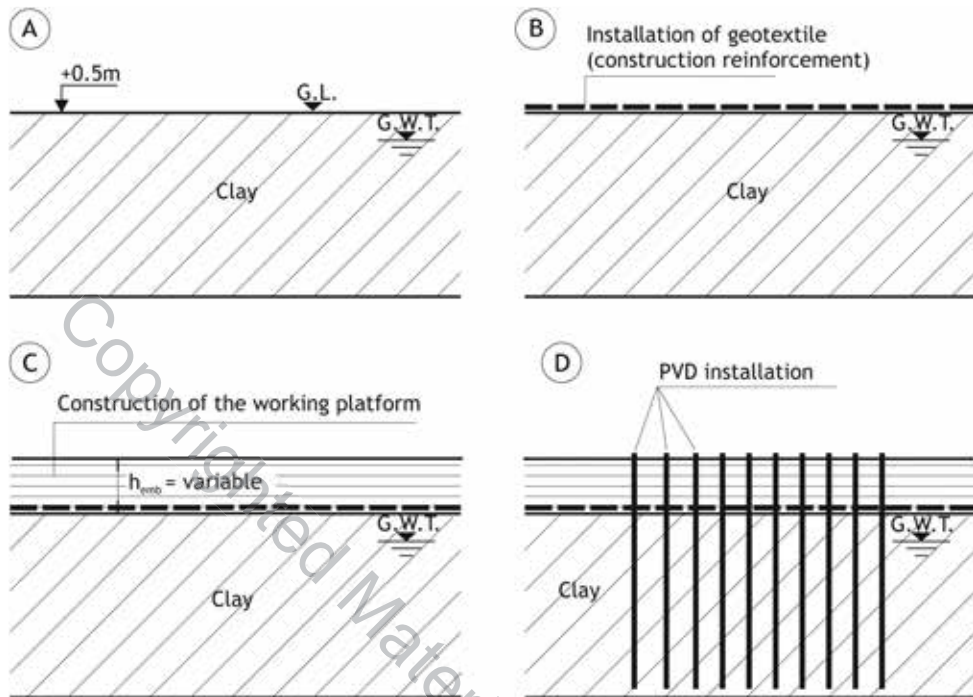

Figure 1.4 Construction of a working platform and vertical drain installation.

between 30 kN/m and 80 kN/m to minimize the loss of fill material (Almeida et al., 2008c).

1.2 CONVENTIONAL EMBANKMENT WITH TEMPORARY SURCHARGE

A conventional embankment is one constructed without any specific settlement or stability control devices. The conventional embankment may be constructed with temporary surcharge (Figure 1.1M), whose function is to speed up the primary settlements and offset all or part of the secondary settlements caused by viscous phenomena not related to the dissipation of pore pressures. The temporary surcharge method is discussed in Chapter 5.

One disadvantage of this construction method is the long time necessary for settlement stabilization in low permeability very soft deposits. Therefore, one must assess the evolution of post construction settlements so that the necessary maintenance is planned.

Another disadvantage of using surcharge is the large amount of related earthworks associated. When the estimated settlements are reached, the temporary surcharge is removed and the removed material can be used as fill in another location, as described in detail in Chapter 5.

1.3 EMBANKMENTS BUILT IN STAGES, EMBANKMENTS WITH LATERAL BERMS AND REINFORCED EMBANKMENTS

When the undrained strength of the upper layers of soft deposit is very low, one should consider the reduction of the embankment height (Figure 1.1D). However, this reduction may not be feasible, due to requirements regarding either regional flood levels, or the geometric project of the road. In such cases, due to the low safety factor against failure, the construction of the embankment (with surcharge) may not be possible in a single stage.

The construction of the embankment in stages (Figure 1.1C), which allows the gradual gain of clay strength over time, is then a construction alternative. Stability must be verified for each stage, and for this evaluation, it is necessary to monitor the overall performance by means of geotechnical instrumentation and *in situ* tests for the necessary adjustments to the project. The increase of the clay undrained strength previously estimated in the design phase should then be verified through vane tests carried out before performing each construction stage. Construction in stages is discussed in Chapters 4 and 6.

The use of equilibrium berms (Figure 1.1B) is another solution that can be adopted to increase the safety factor (F_s) regarding failure. When there are restrictions as to the length of berms, or to reduce the amount of earthworks, a basal reinforcement (e.g., Magnani et al., 2009, 2010) may be installed (Figure 1.1A) with the goal of increasing the F_s and better distributing stresses. These two solutions to increase the F_s are addressed in the Chapter 6. The geosynthetic reinforcement must be installed after the installation of the vertical drains to avoid mechanical damage to the reinforcement.

1.4 EMBANKMENT ON VERTICAL DRAINS

The early vertical drains used were sand drains, which were subsequently replaced by Prefabricated vertical drains, (PVDs). The PVDs consist of a plastic core with channel-shaped grooves, encased in a low weight nonwoven geosynthetic filter, as shown in Figure 1.5A.

The drainage blanket of embankments over PVDs, is initially constructed, which also functions as a working platform (Figure 1.4), followed by the PVD installation and the construction of the embankment. In the driving process, the PVD is attached to a driving footing, which ensures that the end of the PVD is well fixed at the bottom of the layer, when the mandrel is removed (Figure 1.5B). In general, PVDs are used in association with temporary surcharge. The installation of the PVDs is carried out using driving equipment with great productivity – about 2km per day, depending on the stratigraphy – if compared to the necessary operations to install sand drains, with important financial impacts. The experience in the west part of Rio de Janeiro has an average productivity of 1km to 2km long of PVDs installed per day, for local conditions (Sandroni, 2006b).

Vacuum preloading (Figure 1.1 K) consists of the concomitant use of surcharge techniques (Figure 1.1 M) and drains (Figure 1.1L), i.e. a system of vertical (and horizontal) drains is installed and vacuum is applied, which has a preloading effect (hydrostatic). The use of PVDs and vacuum preloading are addressed in Chapter 5.

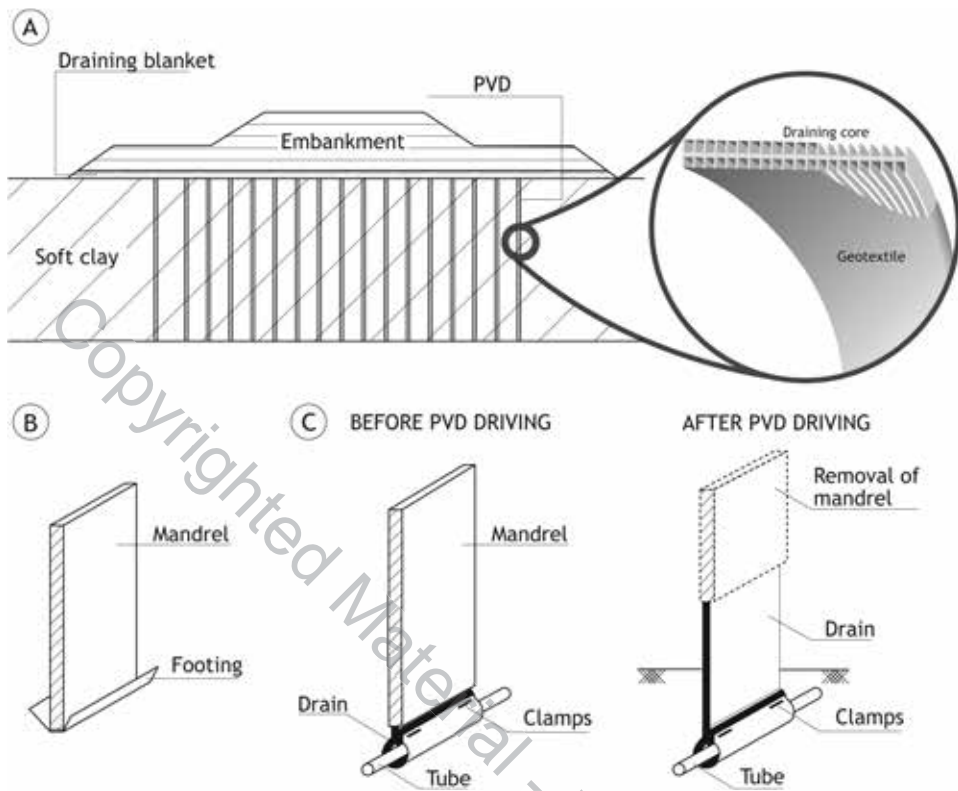

Figure 1.5 Scheme of an embankment on PVDs: (A) schematic cross section with equilibrium berms; (B) detail of the anchoring mandrel and footing of PVD; (C) detail of the driving mandrel and anchoring tube of PVDs.

1.5 LIGHTWEIGHT FILLS

The magnitude of primary settlements of the embankments on layers of soft soils is a function of increased vertical stress caused by the embankment built on the soft soil layer. Therefore, the use of lightweight materials in the embankment reduces the magnitude of these settlements. This technique, known as lightweight fill (Fig 1.1E), has the additional advantage of improving stability conditions of these embankments, also allowing for faster execution of the work and lessening differential settlements.

In Table 1.1 specific weights of certain materials are presented. These materials introduce voids into the embankments and are considered lightweight materials, such as, for example, expanded polystyrene (EPS), concrete pipes/galleries, etc.

Among the listed materials, EPS has been the most used (van Dorp, 1996), because when compared to other materials, it has a smaller specific weight (0.15 to 0.30 kN/m^3) and combines high resistance (70 to 250 kPa) with low compressibility (elastic modulus of 1 to 11 MPa). There are EPS with different weights and, strength, and when choosing an EPS, one must take into account the use of the embankment and the mobile

Table 1.1 Specific weights of lightweight materials for embankments.

Material	Specific weight (kN/m ³)
Expanded polystyrene – EPS (foam or similar)	0.15 to 0.30
Concrete pipes (diameter: 1 m to 1.5 m; wall thickness: 6 to 10 cm)	2 to 4
Shredded tires	4 to 6
Expanded clay	5 to 10
Sawdust	8 to 10

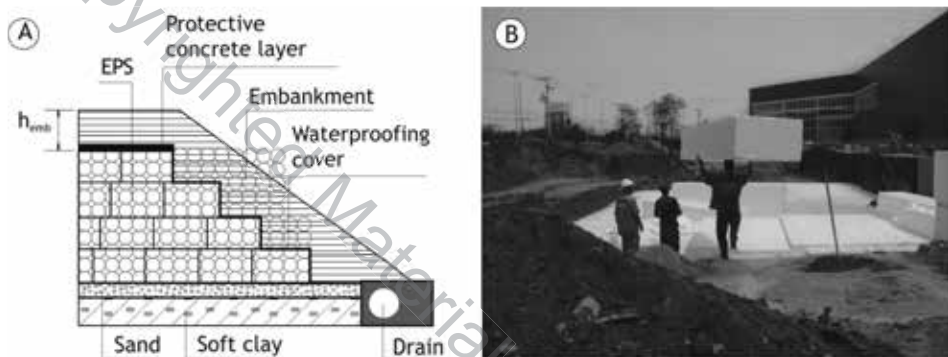

Figure 1.6 Use of EPS on embankments on soft soils: (A) cross section of an embankment built with EPS; (B) detail of the construction of an EPS embankment (Lima and Almeida, 2009).

loads. Figure 1.6 gives an example of lightweight fill, where the EPS core is surrounded with actual fill material with greater weight. In addition to the embankment, a protective concrete layer may be built, i.e. a slab approximately 10 cm to 15 cm thick on the lightweight fill, to redistribute stresses on the EPS, avoiding the punching of this material, caused mainly by vehicular traffic. Considering the load of the surrounding embankment and slab, preloading of the soft soil shall be done, with the use of vertical drains (usually partially penetrating) during the necessary period. The EPS may be sensitive to the action of organic solvents, thus it must be protected by a waterproofing cover insensitive to these liquids, as indicated in Figure 1.6A.

The thickness h_{emb} indicated in Figure 1.6 depends on the applied loads, i.e. the use of the area. On low traffic and low load sites, this thickness will be smaller than in high traffic areas.

If the area of the embankment with EPS is subject to flooding, the EPS may float, compromising the stability and overall behavior of the embankment. In this case, the EPS base should be installed above the maximum predicted water level.

The lightweight embankment with EPS may have several formats, depending on its usage, with typical block dimensions of $4.00 \times 1.25 \times 1.00$ m, but it is possible to use blocks with different dimensions according to the demands of each project, or it is even

possible to specifically cut the blocks on the worksite (Figure 1.6B). The high cost of EPS may render their implementation unsuitable in areas distant from the EPS factory, due to the cost of transporting large volumes of EPS required for the embankments.

1.6 EMBANKMENTS ON PILE-LIKE ELEMENTS

Embankments on pile-like elements (Figure 1.1F,G,H) are those in which all or part of the load of the embankment is transmitted to the more competent foundation soil, underlying the soft deposit and will be addressed in Chapter 7.

Embankments can be supported on piles or columns made of different materials. The stress distribution from the embankment to the piles or columns is done by means of a platform with caps, geogrids or slabs. Embankments on pile-like elements minimize or even – depending on the adopted solution – eliminates settlements, in addition to improving the stability of embankment. One advantage of this construction method is reducing the construction schedule of the embankment, since its construction may be done in one stage, in a relatively short period.

The treatment of soft soil with granular columns (Figure 1.1F), in addition to producing less horizontal and vertical displacements when compared to conventional embankments or embankments on drains, also dissipates pore pressures through radial drainage, which speeds up the settlements and increases shear resistance of the foundation soil mass. The encasement of these columns using tubular geosynthetics with high modulus maximizes their performance.

Piled embankment (Figure 1.1H) uses the arching effect (Terzaghi, 1943), therefore allowing the stresses of the embankment to be distributed to the piles. The efficiency of the arching increases as the height of the embankment increases, consequently distributing the load to the caps and the piles (Hewlett and Randolph, 1988). Currently, geogrids are used on the caps to increase the spacing between piles.

1.7 CONSTRUCTION METHODOLOGIES FOR HARBOR WORKS

Soft soil deposits are common in harbor works, which are usually located in coastal areas, because of the amount of sediments that occur over thousands of years, or even recent sediment deposits, due to anthropogenic activities. In Brazil, examples of such areas are, among others, ports of Santos (Ramos and Niyama, 1994), Sepetiba (Almeida et al., 1999), Itaguaí (Marques et al., 2008), Suape (Oliveira, 2006), Itajaí-Navegantes (Marques and Lacerda, 2004), Natal (Mello, Schnaid and Gaspari, 2002), Rio Grande (Dias, 2001), and also in port areas in the Amazon region (Alencar Jr. et al., 2001; Marques, Oliveira and Souza, 2008).

Harbor works (Mason, 1982) consist essentially of an anchoring dock with a yard for holding containers in general. Figure 1.7 shows possible construction schemes for port works (Mason, 1982; Tschebotarioff, 1973). The quay is usually a structure supported by piles, which can either have an associated retaining structure or not. Examples of quays with frontal retaining structures are indicated in Figure 1.7A,B,C. The case shown in Figure 1.7A includes a relief platform. This procedure has the advantage of decreasing the active pressures on the retaining structure. In the case

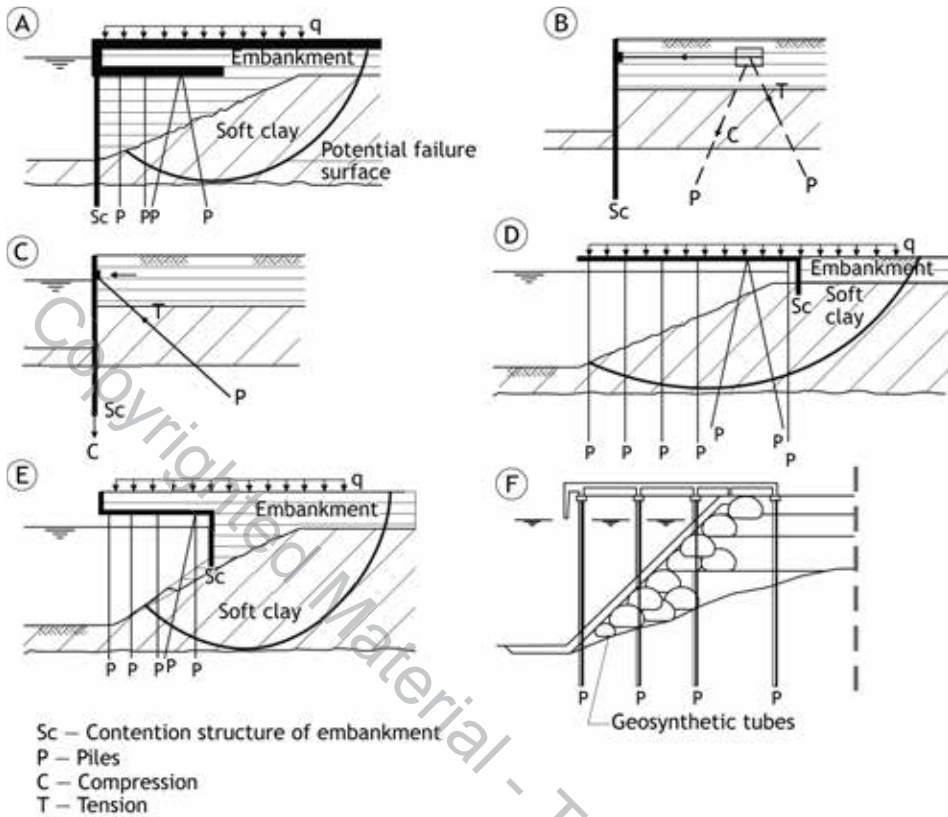

Figure 1.7 Details of geotechnical solutions in port areas.

shown in Figure 1.7 B, the retaining structure is supported by a system of two inclined piles, one being compressed and the other being tensioned. In Figure 1.7C, the retaining structure is supported by inclined piles working in tension. The compression stresses are then transmitted to the retaining structure.

In modern harbor works, which handle large vessels (the current dredging requirements reach depths of about 20 m), the retaining structures must reach great depths, so as to have the appropriate depth of embedment, in particular in the case of very thick compressible layers. Consequently, the previously described retaining structures have high costs, and alternatives have been proposed as indicated in Figure 1.7D,E. In the case shown in Figure 1.7D, the quay was expanded, and in the case of Figure 1.7E, a relief platform was used.

Figure 1.7F is a variant of Figure 1.7E and consists of an embankment, traditionally constructed with rock-fill, on the interface with the yard. An alternative to the rock-fill is the use of geotextile tubes filled with granular material or with soil cement.

Stability and settlement analysis should be carried out, regardless of the option adopted among the cases described here, and potential critical failure surfaces are shown in Figure 1.7A,D,E. In harbor works, the typical container surcharge is in the

PHASE 1

- 1 - PVD installation
- 2 - Area preparation: working platform geosynthetics and draining blanket
- 3 - Placing and installation of geosynthetic tubes
- 4 - Partial construction of the dikes
- 5 - Filling of geosynthetic tubes with the contaminated sediment to be treated

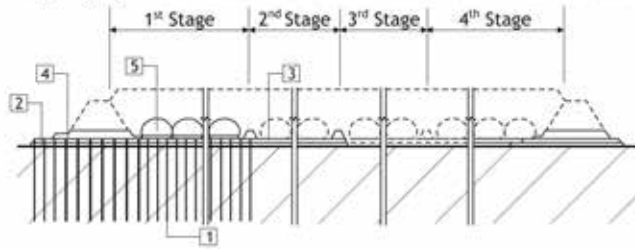

PHASE 2

- 6 - Continuing construction of dikes
- 7 - Construction of embankment
- 8 - Overload placement to accelerate settlement

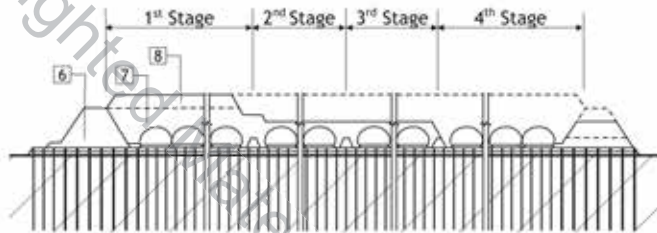

PHASE 3

- 9 - Removal of surcharge on 1st stage and placement on 2nd stage
- 10 - Displacement of surcharge from one stage to the next
- 11 - Repeat process until all areas have been overloaded

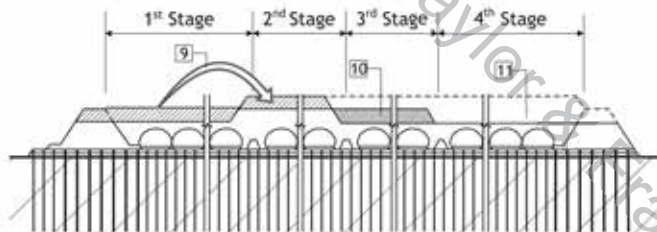

PHASE 4

- 12 - Completed and stabilized embankment

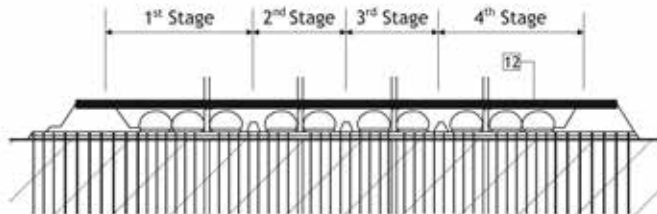

Figure 1.8 Detail of the methodology for disposal of confined sediment.

order of 50 to 80 kPa, and the magnitude of the allowed post construction settlements will depend on technical and operational factors.

In general, harbor works require dredging thick layers of sediment. In these cases, it is common that the superficial layers present such a contamination level, that environmental agencies will not allow the disposal into water bodies. The alternative has been to dispose the sediments on land and on the harbor work site or offshore. One solution is the disposal of these dredged sediments in geotextile tubes (Leshchinsky et al., 1996; Pilarczyk, 2000), which allow the dehydration of the sediment. Also, by means of physical-chemical processes, the contaminant gets attached to the sediment and the dried fluid is then disposed of under environmentally controlled conditions.

Figure 1.8 presents a constructive scheme adopted for the disposal of such contaminated sediments in confined areas on land, which has 4 phases with 12 constructive steps explained in the figure. In some cases, the geosynthetic tubes are stacked in two or three layers. Once the landfill is completed, it can then be used as a storage area.

1.8 FINAL REMARKS

The planned use of the area has an important influence on the most appropriate constructive technique of embankment on soft clay. For example, on embankments of port yards, the owner may accept post construction settlements and prefer to make periodic

Chart 1.1 Summary of construction methodologies and their characteristics.

Construction methodologies	Characteristics
Total or partial removal of soft layer	Effective, fast, high environmental impact; boreholes are necessary for measuring the quantity of removed/remaining soil
Soil expulsion with controlled rupture (displacement fill)	Used for deposits of small thickness and very dependent on local experience; boreholes are necessary to gauge the thickness of the removed/remaining soil
Conventional embankment	Stabilization of settlements is slow
Construction in stages	Used, in most cases, with vertical drains; it is necessary to monitor the clay strength gain; it is not favorable for short deadlines
Vertical drains and surcharge	Used to accelerate settlements, large accumulated experience. Temporary surcharge may minimize or suppress secondary settlements
Berms and/or reinforcement	Frequently adopted; it is necessary to assess whether the tensile strength of the reinforcement is actually mobilized <i>in situ</i>
Use of lightweight materials	Ideal for tight deadlines; relatively high costs; its use has increased
Embankments on piles with geogrid platform	Ideal for tight deadlines; various layouts and materials can be used
Granular columns (granular piles)	Granular columns that may or may not be encased with geotextile; settlements are accelerated due to the draining nature of granular columns; geogrids are sometimes installed above the granular columns
Vacuum preloading	Can partially substitute the need for surcharge with fill material; horizontal strains are much smaller than those of conventional surcharge

maintenance on the embankment, rather than investing initially on the stabilization of the settlements. However, for real estate, post construction settlements are unacceptable, since the constructor will not return to the site. On highways, settlements on bridge approaches reduce the comfort and safety of users, and on railroads, the post construction settlements should be small to minimize high maintenance costs, mainly related to the disruption of traffic. In the case of high-speed trains, for example, post construction settlements should be null.

Chart 1.1 summarizes the constructive methodologies presented in this chapter and their main features. For very soft soils it is common to use several construction techniques in parallel. For example, in the southeastern region of Brazil, particularly in the port of Santos area and in the West zone of Rio de Janeiro, in some cases, the choice has been to adopt reinforced embankments constructed in stages on vertical drains with berms and surcharge (Almeida et al., 2008c).

The decision for one executive methodology in detriment to another is a function of the geotechnical characteristics of the deposits, the use of the area (including the neighborhood), construction deadlines and the costs involved.

Copyrighted Material - Taylor & Francis