



Construction Planning and Implementation Using ANSI/TIA-322 and ANSI/ASSE A10.48

January 11, 2017

11:00 am – 12:00 pm EDT

- **James Ruedlinger**, Manager Engineer, Crown Castle
- **Mark Malouf**, President, Malouf Engineering International
- **John Erichsen**, Owner, EET LLC (moderator)
- **Limor Schafman**, Director of Content Development, TIA (webcast host)

www.TiaOnline.org @TIAOnline standards@tiaonline.org

Visit our website to learn more about upcoming workshops.



ANSI/TIA-322-2016 & ANSI/ASSE A10.48-2016

Construction Planning and Implementation for Communication Structures

***Working Together to Provide Safe Working
Environments for Communication Structures Through
Understanding and Application of the Standards***

January 11, 2017



AGENDA

- ❑ **ANSI/TIA-322 & ANSI/ASSE A10.48 Overview**
- ❑ **Roles & Responsibilities**
- ❑ **Standardized Common Terminology & Definitions**
- ❑ **Construction Classes & Rigging Plans**
- ❑ **Structure Strength Requirements Under Construction**
- ❑ **Gin Poles**



ANSI/TIA-322 & ANSI/ASSE A10.48 Overview

ANSI/TIA-1019 (published in 2004)

- Represented the first uniform engineering and operational use telecommunications construction standard for highly specialized lifting devices known as gin poles
- Developed by leading experts representing TIA and NATE through a partnership with OSHA to drive construction safety initiatives within the industry

ANSI/TIA-1019-A (published in 2011)

- Expanded on ANSI/TIA-1019 to include combined structure analysis and design criteria during construction along with means and methods (aka procedures and practices) beyond strictly gin pole activities
- Identified key roles in the telecommunications construction process



ANSI/TIA-322 & ANSI/ASSE A10.48 Overview

ANSI/TIA-1019-A Shortcomings:

- Developed by leading experts representing primarily Broadcast related work which represents only a small niche in the telecommunications industry (*assumed baseline user knowledge*)
- Mixed design and operational use content proved to be difficult to locate and clearly identify in practical application
- Did not cover (or only touched on):
 - *Fall Protection and Rescue*
 - *RF Safety*
 - *Pre-Job Planning/Site Risk Assessment*
 - *Demolition*
 - *Training*
- Lifting content focused on gin pole applications and neglected specific concerns with more common lifting block arrangements on smaller structures
 - *Tag Forces*
 - *Load Line and Tag Line Forces*
 - *Rigging Attachments*
- Confusion in Construction Classes



ANSI/TIA-322 & ANSI/ASSE A10.48 Overview

Confusion with ANSI/TIA-1019-A Construction Classes

- Did not define how to determine “rigging forces” for Construction Class limits
- No lifting limit established for Class III
- Did not distinguish between external lifting systems (e.g. cranes, lifts, etc.) and systems attached to the structure
- Construction activities requiring engineering involvement not well clarified (what activities constitute Class IV)

Table 2-1: Construction Classifications

Class	Description	Minimum Level of Responsibility
I	The scope of work does not affect the integrity of the structure and the proposed rigging loads are minor in comparison to the strength of the structure, but not exceeding rigging forces greater than 650 lbs.	Competent Rigger
II	The scope of work involves the removal or the addition of appurtenances, mounts, platforms, etc. that involve minor rigging loads in comparison to the strength of the structure, but not exceeding rigging forces greater than 1,000 lbs.	Competent Rigger
III	Rigging plans that involve work outside the scope of Class I, II or IV construction.	Qualified Person
IV	The scope of work involves custom or infrequent construction methods, removal of structural members or unique appurtenances, special engineered lifts, and unique situations.	Qualified Person with Qualified Engineer

Rigging forces?

No lifting limit

Activities not well clarified



ANSI/TIA-322 & ANSI/ASSE A10.48 Overview

ANSI/TIA-1019-A “Rigging Forces”

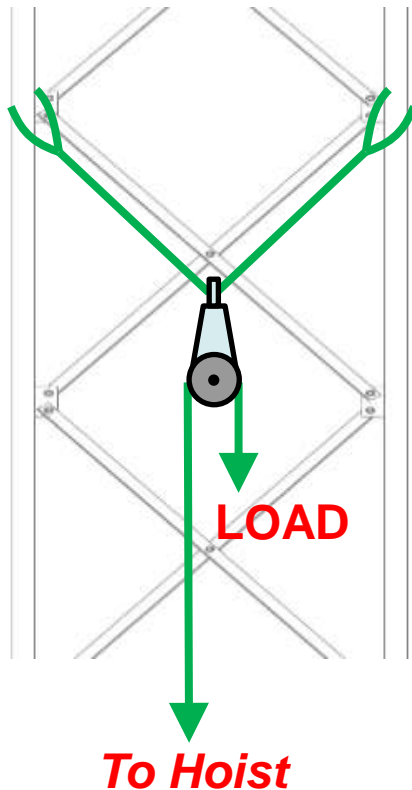

Example:

Gross Load = 300 lbs

Straight Tag Lift with Load Angle of 7° and Tag Angle of 60°

Load Line Force = 384 lbs

Tag Line Force = 94 lbs

Top Block Force = 767 lbs (7° Included Angle)

Top Bridle Sling Forces = 443 lbs ea. (60° Sling Angle)

Heel Block Force = 543 lbs (90° Included Angle)

Heel Bridle Slings = 314 lbs ea. (60° Sling Angle)

What is the effective “Rigging Forces”?

Under A10.48, lifting limits are based on Gross Load



ANSI/TIA-322 & ANSI/ASSE A10.48 Overview

- As of **January 1, 2017**, the ANSI/TIA-1019-A replaced by the ANSI/TIA-322 and ANSI/ASSE A10.48

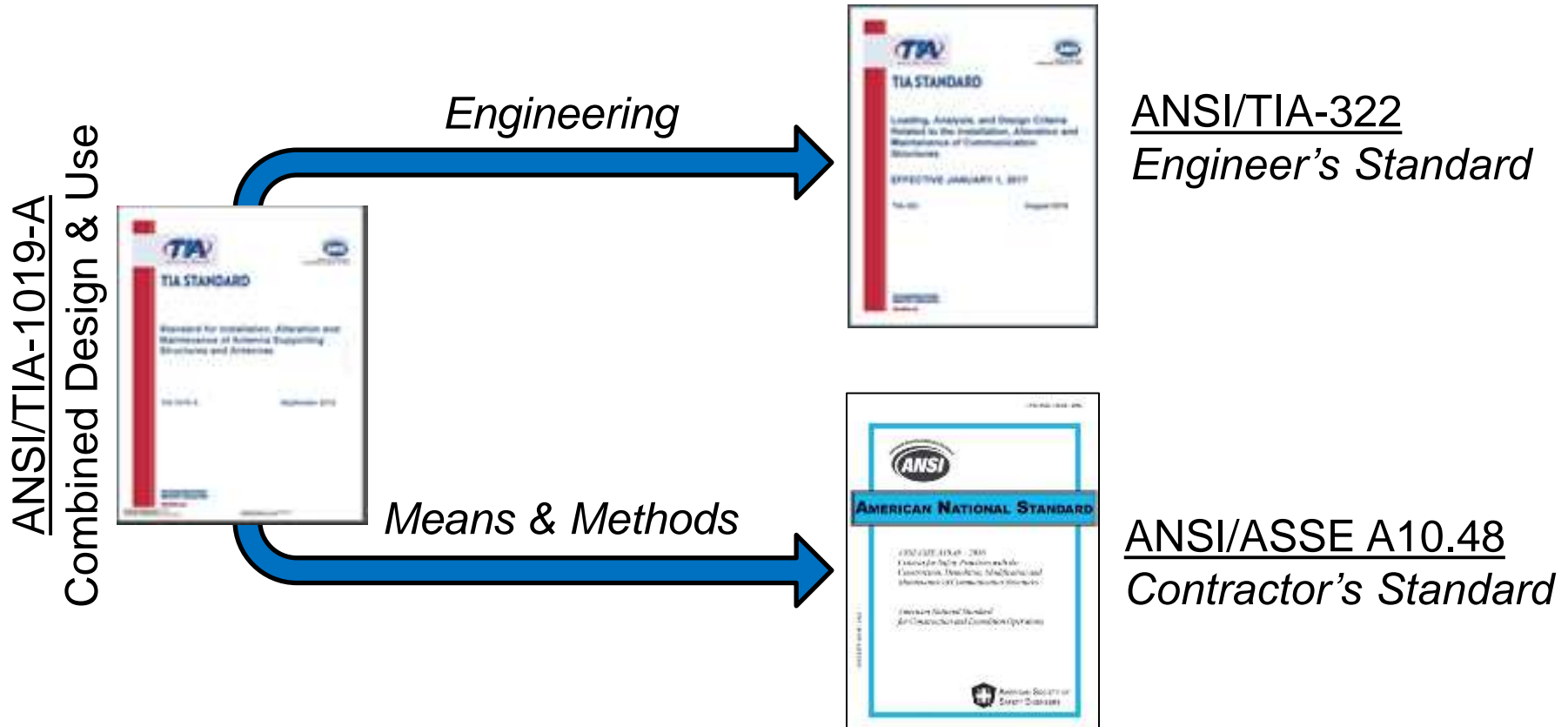



ANSI/TIA-322 & ANSI/ASSE A10.48 Overview

- **ANSI/TIA-322 and ANSI/ASSE A10.48 build upon core engineering and accepted safe work practice concepts presented in the ANSI/TIA-1019-A with expanded and focused content to facilitate greater understanding and improved communications between engineers and contractors when planning and assessing tower construction activities**
- **General conformance to all minimum construction requirements set forth in the ANSI/TIA-1019-A are satisfied or exceeded through proper application of the minimum criteria now established within the ANSI/TIA-322 and ANSI/ASSE A10.48 standards**
- **When properly utilized, results in reduced construction costs through planning, better procedures, increased risk identification and mitigation, and substantial improvements to overall construction safety and work quality**



ANSI/TIA-322 & ANSI/ASSE A10.48 Overview

Roles & Responsibilities



Roles & Responsibilities

General Contractor (ref. A10.48)

- For all Classes of construction, GC must provide a designated and qualified onsite “**Competent Rigger**” to identify hazards, take corrective measures to mitigate hazards, and to implement all necessary construction means and methods.
- For Class III and IV construction, GC must provide or engage a designated and qualified “**Qualified Person**” to assist in developing the rigging plan and to communicate construction requirements to all stakeholders.
- For Class IV construction, GC’s “**Qualified Person**” must assist in rigging plan development while coordinating and engaging necessary involvement of a “**Qualified Engineer**” to assess supporting structure under all pertinent construction phases

Roles & Responsibilities

Competent Rigger vs. Qualified Person (ref. A10-48)

Competent Rigger:

- *Required for ALL classes of construction*
- *Must be onsite*
- *Communicates directly with Qualified Person when questions arise on construction activities*

Qualified Person:

- *Only required on Class III and IV construction activities*
- *May be onsite, in office, or same individual serving as either Competent Rigger or Qualified Engineer (aka Supervising Engineer)*
- *Communicates directly with Qualified Engineer when questions arise on construction activities*





Roles & Responsibilities

Engineering

- Engineer of Record (EOR)
- Qualified Engineer
- Supervising Engineer

Roles & Responsibilities

Engineer of Record (EOR)

- Registered professional engineer with expertise in the discipline applicable to the scope of work and who assumes responsibility for the design and structural adequacy of the structure in its **COMPLETED** state





Roles & Responsibilities

Qualified Engineer

- Registered professional engineer who is knowledgeable and experienced in the communication structures industry and capable of understanding the contractor's rigging plan and the scope of work impact upon the structure, and is responsible for analyzing the structure's strength and stability while accounting for construction loads in accordance with the ANSI/TIA-322 standard
- The Qualified Engineer does **NOT** have the responsibility for development of the rigging plan, field supervision, or implementation of the construction means and methods



Roles & Responsibilities

Supervising Engineer

- Accepts all responsibilities as defined for a Qualified Engineer and assumes or shares the additional responsibilities as defined for a Qualified Person, and may have responsibility in specifying certain portions of the construction means and methods
- *Simply put, a Supervising Engineer assumes all or a portion of the responsibilities in developing the rigging plan and may additionally provide field supervision or other means of oversight to verify execution of the planned construction means and methods*





ANSI/TIA-322 & ANSI/ASSE A10.48 Overview

Standardized Common Terminology & Definitions

Standardized Common Terminology & Definitions

Standardized terminology and definitions used for setting a common language to facilitate and improve communications between engineers and contractors

- *Competent Rigger*
- *Qualified Person*
- *Engineer of Record*
- *Qualified Engineer*
- *Supervising Engineer*
- *Rigging Plan*
- *Construction Loads*
- *Gross Load*
- *Load Chart*
- *Crown/Top Block*
- *Heel/Base Block*
- *Traveling Block*
- *Load Control Line*
- *Tag Line*
- *Trolley Tag*
- *Means and Methods*
- *Panel Point*
- *Special Engineered Lift*
- *Strength Efficiency Factor*





Standardized Common Terminology & Definitions

- **Establishes key stakeholder titles and responsibilities**
- **Standardizes terminology for common equipment and components involved in telecommunications construction**
- **Provides standard set of symbols and notations for consistency in load charts and construction engineering reviews**



ANSI/TIA-322 & ANSI/ASSE A10.48 Overview

Construction Classes & Rigging Plans

Construction Classes & Rigging Plans

Overview

- **Construction Class determines the minimum personnel which must be provided or engaged by the contractor in the development, review, and implementation of their Rigging Plan**





Construction Classes & Rigging Plans

When Is A Rigging Plan Required?

- In short, a rigging plan in accordance with ANSI/ASSE A10.48 is required for **ALL** tower construction activities including, but not limited to:
 - Tower installation and/or decom of equipment/appurtenances
 - Tower structural modifications to members/components
 - Tower installation or decom/demo
 - Tower foundation installation/modification
 - Any construction activity involving telecommunication structure
- **ANSI/ASSE A10.48 provides four Construction Classes**
 - Construction classes have lifted load limits
 - Categorized by potential impact to supporting structure's strength/stability
 - Categorized by personnel involved in planning/implementation process
 - Require varying levels of documentation and involvement by project stakeholders
- **Rigging plans for Class II, III, and IV construction must be documented**

Construction Classes & Rigging Plans

Construction Class Considerations

Four Construction Classes With **Three** Basic “Buckets” Which Determine Class:

1) Construction Scope of Work

- Includes any potential impacts to supporting structure’s strength and/or stability (includes foundation)

2) Maximum Gross Load Weight when Lift System is Attached to Structure

- Staged maximum limits at 350 lbs, 500 lbs, and 2,000 lbs

3) Construction Procedures

- Includes construction sequencing and duration
- Must account for individuals’ experience implementing work





Construction Classes & Rigging Plans

Rigging Plan Overview

Rigging Plan:

A systematic and detailed presentation showing the equipment and procedures required for construction in accordance with the ANSI/ASSE A10.48 that will provide for the safety of personnel and for the stability of the structure and lifted components.

Basic Rigging Plan Elements Include:

- Project/Site Specific Information
- Key Stakeholders Responsible for Construction Planning and Implementation
- Construction Class
- Scope of Work
- Supporting Structure Information & Site Layout
- Construction Sequence and Duration
- Lifting System Details/Info & Lifted Load(s) Information
- Construction Equipment and Rigging Information Including Size and WLL Capacity, and Attachment/Anchorage Details
- Any Special Procedures, Details, or Documents Needed to Ensure A Safe Work Environment During Construction
 - *Monitoring requirements, proof testing requirements, etc.*



Construction Classes & Rigging Plans

CLASS IV
CLASS III
CLASS II
CLASS I

Class I Rigging Plans

“Minimum” Required Class For The Following:

- Gross lift loads for lift systems attached to the structure shall not exceed **350 lbs.** (excludes cranes or other lifting systems not attached to structure)
- Construction activities do **NOT** adversely impact the strength or stability of the supporting structure and SOW does not require any special, custom, or unique construction methods.
- Prepared by Qualified Person and/or Competent Rigger



Construction Classes & Rigging Plans

Class II Rigging Plans

“Minimum” Required Class For The Following:

- Gross lift loads for lift systems attached to the structure shall not exceed **500 lbs.** (excludes cranes or other lifting systems not attached to structure)
- Construction activities do **NOT** adversely impact the strength or stability of the supporting structure and SOW does not require any special, custom, or unique construction methods.
- Prepared by Qualified Person and/or Competent Rigger



Construction Classes & Rigging Plans

Class III Rigging Plans

“Minimum” Required Class For The Following:

- Gross lift loads for lift systems attached to the structure shall not exceed **2,000 lbs.** (excludes cranes or other lifting systems not attached to structure)
- All new structure and foundation construction
- All construction activities involving cranes or other lifting devices not attached to structure
- Construction activities do **NOT** adversely impact the strength or stability of the supporting structure and SOW does not require any special, custom, or unique construction methods.
- Prepared by Competent Rigger and/or Qualified Person



Construction Classes & Rigging Plans

Class IV Rigging Plans

CLASS IV
CLASS III
CLASS II
CLASS I

- Any planned lift exceeding **2,000 lbs** where the rigging system is directly attached to structure (excludes cranes or other lifting systems not attached to structure)
- Removal of structural members, or any activities involving reduced supporting structure strength or stability (i.e. structural member removal/replacement, guy wire installation/removal/replacement, significant foundation work impacting stability, etc.)
- Removal of unique appurtenances where either imposed construction loading, or supporting structure strength/stability is questioned by Contractor
- SOW involves custom or infrequent construction methods
- Special engineered lifts
- Unique situations
- All tower decom/demolition
- Prepared by Competent Rigger and/or Qualified Person with a Qualified Engineer



ANSI/TIA-322 & ANSI/ASSE A10.48 Overview

Structure Strength Requirements Under Construction



Structure Strength Requirements Under Construction

ANSI/TIA-222-G used for the basis of all supporting structure strength and stability investigations

- **Operational Loads**

- Construction loads imposed during active operations (e.g. lifting, pulling guy wires, etc.)
- Structure reviewed using a uniform effective 30 mph wind speed along with all applicable construction loads using a minimum impact factor of 1.3
- Over 30 mph considered special condition (material handling concerns, etc.)

- **Non-Operational Loads**

- Construction loads imposed during inactive times from rigging system, material, equipment, etc. (work breaks, overnight, etc.)
- Structure reviewed using non-operational wind load based upon construction duration (not less than 45 mph)
- Must account for varying stages in construction

Structure Strength Requirements Under Construction

Operational Strength Load Combination:

$$1.2 D_s + 1.0 D_g + 1.6 I_c C_1 + 1.6 W_1$$
$$0.9 D_s + 1.0 D_g + 1.6 I_c C_1 + 1.6 W_1$$

Where:

D_s – Structure Dead Load

D_g – Guy Dead Load

I_c – Impact Factor (Min 1.3)

C_1 – Operational Construction Loads

W_1 – Operational Wind Load (30 MPH)



Structure Strength Requirements Under Construction

Non-Operational Strength Load Combination:

$$1.2 D_s + 1.0 D_g + 1.6 C_2 + 1.6 W_2$$
$$0.9 D_s + 1.0 D_g + 1.6 C_2 + 1.6 W_2$$

Where:

D_s – Structure Dead Load

D_g – Guy Dead Load

C_2 – Non-Operational Construction Loads

W_2 – Non-Operational Wind Load (Based on Duration)



NOTE: Non-operational construction loading combinations shall be evaluated regardless of the anticipated duration of the construction activity to account for unforeseen delays.



Structure Strength Requirements Under Construction

Non-Operational Loads

- Appropriate construction durations utilized for the analysis of each configuration phase impacting structures' strength of stability

Construction Duration	Non-Operational Wind Requirement
One Work Day	45 mph
Less Than 24 hours	54 mph
24 hours to Less Than 1 Week	60 mph
1 Week to Less Than 6 Weeks	68 mph
6 Weeks to 6 Months	72 mph
Greater Than 6 Months	90 mph

- *Reduced wind loads account for reduced reference period (i.e. maintain same serviceable lifetime structure reliability over shorter exposure period)*
- *For durations greater than 1 week during hurricane season, appropriate plans that can be implemented before the onset of a forecasted hurricane must be prepared and included in the rigging plan (down rig, install additional bracing/shoring, temp guys, etc.) to meet strength requirements for full site hurricane wind speeds*



ANSI/TIA-322 & ANSI/ASSE A10.48 Overview

Gin Poles

Gin Poles

Configurations

- **Two Primary Gin Pole Configurations**



Vertical

(Gin Pole Mast Within 1.5° Of Vertical)



Tilted

Gin Poles

Typical Components

- **Typical Gin Pole Components:**
 - **MAST:** Triangular or square lattice sections are most common, but can be of a single pipe or member.
 - **ROOSTER HEAD:** Top sheave assembly capable of rotating load line 360 degrees.
 - **BRIDLE AND BASKET SUPPORTS:** Needed to hold or support gin pole on tower structure.
 - **LOAD, JUMP & TAG LINES:** Used to raise and lower gin pole, lift gross loads, and tag out and control a lifted load.
 - **TRACK:** May or may not be part of system, but when used aides in support of pole during its positioning on the tower.

Gin Poles

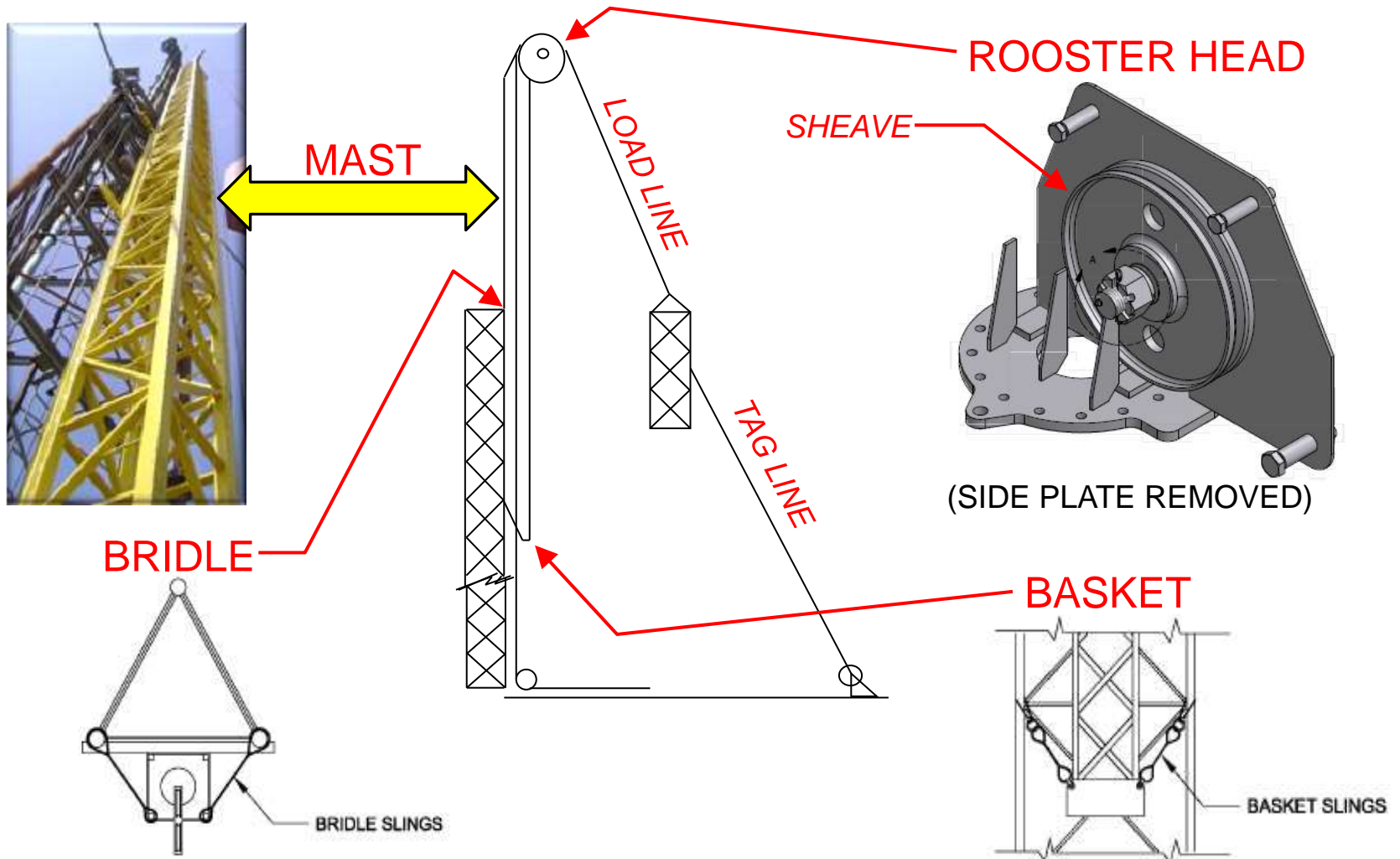

Gin Poles

Types

- Gin poles cover a broad spectrum of specialty lifting devices from a sophisticated latticed mast with a rooster head assembly to a simple tubular pole with a top block, and may utilize either steel wire rope or synthetic rope for the primary load line.





Gin Poles

Certification, Marking & Documentation Requirements

- Gin pole must be rated and certified to ANSI/TIA-322
- Gin poles and associated components must be permanently and clearly marked, and referenced to their applicable load chart(s)
- Minimum onsite documentation must include load chart(s), current inspection records, and any applicable assembly details

Inspection checklist for gin poles with columns for 'Pass', 'Fail', and 'Notes'. The checklist includes items such as 'Is the gin pole rated for the intended use?', 'Are the guy wires properly secured?', and 'Is the gin pole free of damage?'.

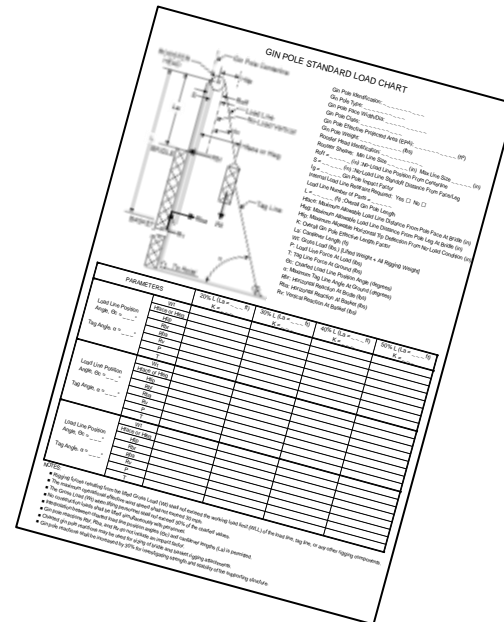



Questions?

*Working Together to Provide Safe Working
Environments for Communication Structures Through
Understanding and Application of the Standards*



Contact Information

John Erichsen, SE, PE

john.erichsen@eetllc.net

(574) 277-0670 ext.701

Mark Malouf, PE, SECB, IPF

mmalouf@maloufengineering.com

(972) 783-2578 ext.106

James Ruedlinger, PE

James.Ruedlinger@crowncastle.com

(812) 459-2053

Marianna Kramarikova

mkramarikova@tiaonline.org

(703) 907-7743



Construction Planning and Implementation Using ANSI/TIA-322 and ANSI/ASSE A10.48

January 11, 2017

11:00 am – 12:00 pm EDT

- **James Ruedlinger**, Manager Engineer, Crown Castle
- **Mark Malouf**, President, Malouf Engineering International
- **John Erichsen**, Owner, EET LLC (moderator)
- **Limor Schafman**, Director of Content Development, TIA (webcast host)

www.TiaOnline.org @TIAOnline standards@tiaonline.org

Visit our website to learn more about upcoming workshops.



TIA Standards - Ordering Information

ANSI/TIA-322 document (Published August 2016, Pages: 74)

Loading, Analysis, and Design Criteria Related to the Installation, Alteration, and Maintenance of Communication Structures

Order: IHS Markit™ Standards Store - <http://www.global.ihs.com>

Call: 1.800.447.2273

Europe and Middle East

+44 1344 328 300

Asia Pacific

+604 291 3600

TIA-222 - Structural Standard for Antenna Supporting Structures – Expected date to be published is Fall 2017.

To join TR-14 Engineering Committee, please contact standards@tiaonline.org