

Contents

Press Brake Tooling

AMADA Quality Tooling

AMADA has been the leader in the production of Precision Press Brakes for over 40 years and we have installed more than 80,000 machines worldwide. The knowledge gained from this experience has confirmed our conviction that the use of superior tooling ensures optimum performance each and every time the Press Brake is used. Using AMADA Press Brake Tooling guarantees you the edge in productivity, putting you ahead of the competition.

	Page		Page
Quality, Laser Marking & Lengths	2	Dies	
How to use this section	3	2V Dies Reversible 88°/90°	40
AFH - AMADA Fixed Height	4	2V Dies Reversible 60°/30°	42
Advantages of AFH	4	Heavy Duty 1V	43
		Heavy Duty 1V Acute	45
		Other Dies	46
Punches		Polycarbonate Dies	47
AFH Punches H=120	6	Polycarbonate Dies - Radius Bend	48
AFH Punches H=90	10	Polyurethane Die Technical Guidelines	49
AFH Punches H=160	13	Polyurethane Holders	50
Punches H=70	14	Polyurethane Die Pads	51
Radius Punches	16	Hemming	52
Colour Radius Punches	20	Hemming & Flattening	53
Multi-Radius Punches	22	Joggle Tools	54
Burring Punches	24	Punch Holder	55
Special Punch Holders	25	Holdings, Blocks & Rails	56
Flattening	25	Rolla V	58
Clamps	26	Accessories	61
Distance Pieces	27	Urethane Sheet & Tape	62
		Tooling Cabinet	62
Dies		Return Bend Limit Graphs	63
AFH 1V Dies V=4	28	Air Bending Tonnage Charts	90
AFH 1V Dies V=6	29		
AFH 1V Dies V=8	30		
AFH 1V Dies V=10	32		
AFH 1V Dies V=12	33		
AFH 1V Dies V=14	35		
AFH 1V Dies V=16	35		
AFH 1V Dies V=18	36		
AFH 1V Dies V=20	37		
AFH 1V Dies V=25	38		
AFH 1V Dies V=32 & V=40	39		



Pressbrake Tooling

Punch Quality

AMADA punches are through hardened from hot formed steel:

- For long lasting high precision
- Surface hardness: 45~50 HRC
- Body strength: **1500 N/mm²**



Die Quality

AMADA dies are AMANIT®, providing:

- Low friction on the shoulder radii
- Highest strength of the body - **1150 N/mm²**
- Corrosion resistance

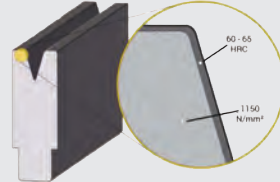

Tooling Features

With innovative heat treatment strategies and special testing techniques we are giving best durability to the steel, not only against failure caused by dead loads but also against fatigue caused by an infinite number of repeated loads.

Complete Laser Marking

All AMADA pressbrake toolings are completely marked by laser. Essential information like tooling type, angle, tonnage, length and radius are marked even on the sectional parts.



Tooling Lengths

Available in solid 835mm, solid 415mm and Sectionalized (sec) lengths for easy one-operator set-ups

Sectionalized Punch (100mm are ears):

100, 10, 15, 15, 20, 40, 50, 150, 300, 100 = 800mm

Sectionalized Die:

100, 10, 15, 15, 20, 40, 50, 150, 400 = 800mm

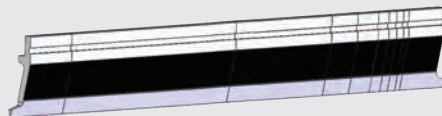
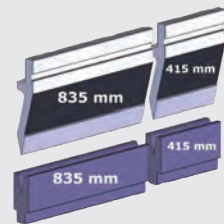

How to use this section

This section should be read as follows:

Example: #604 Punch

Angle	Radii	Code	Length	Price	Tool #604 - 100 t/m
88°	R0.6	6047061	835mm	£185	
		6047062	415mm	£107	
		6047063	Sec	£278	
90°		6049061	835mm	£185	
		6049062	415mm	£107	
		6049063	Sec	£278	

1. Tool Angle (colour coded)
2. Standard Punch Tip Radius
3. Code number for radii specified
4. Tool length
5. Tool number
6. Allowable tonnage – tonnage per metre
7. Previous tool number (if applicable)
8. Radii available – please ask for price
9. Ear tonnage – tonnage per metre

AFH - AMADA Fixed Height

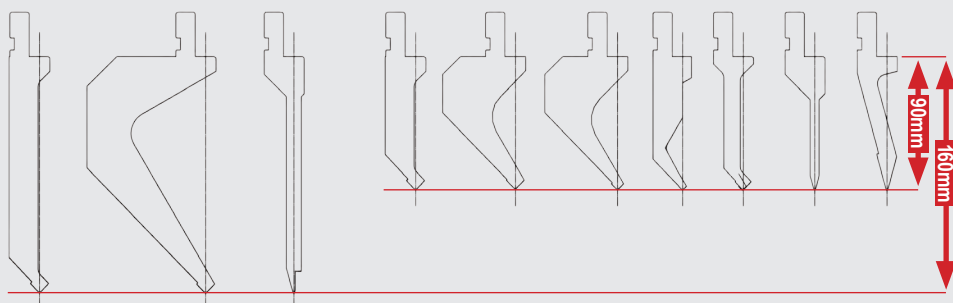
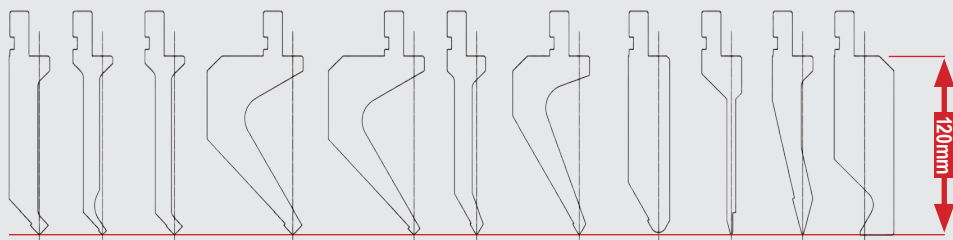

Press Brake
Tooling

V=4 to 25 86°/88°/90° V=6 to 25 60° V=6 to 25 30°

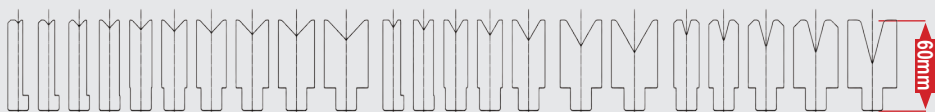

Advantages of AFH

Single V Dies

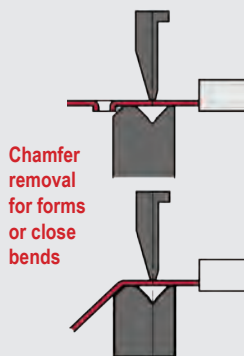
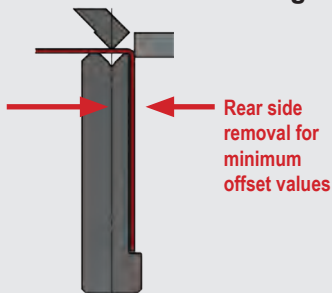

Advantages of **AFH**

Deeper box bending capability and enlarged bend return area

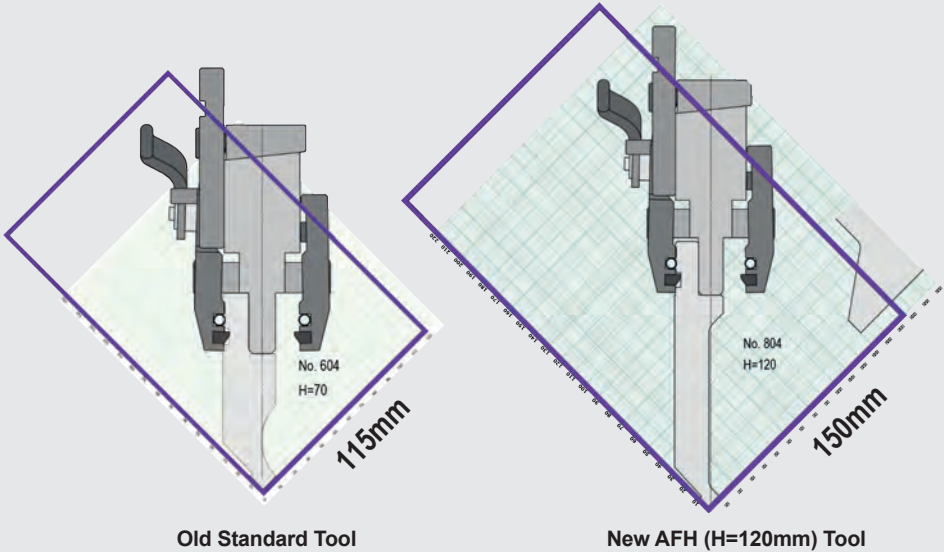

Press Brake
Tooling

Multiple punch and die profiles have a common height making pressbrake set-ups fast and stage bending easy.

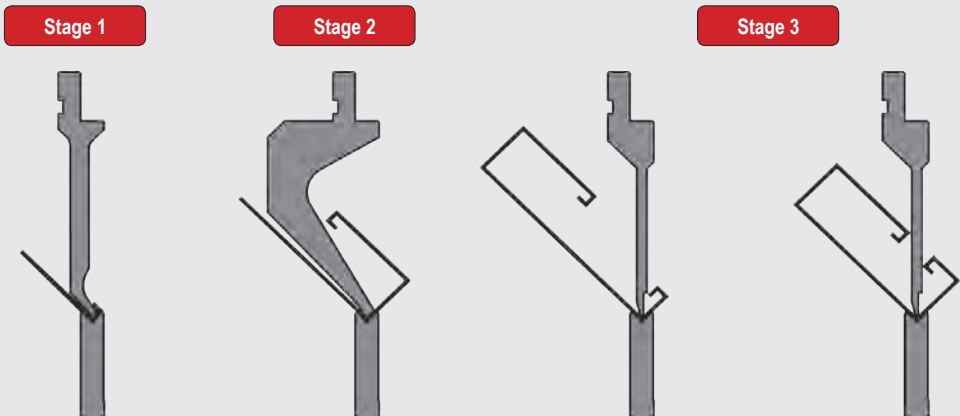

This example shows 3 different profiles in one machine bed set-up

AFH Punches H=120

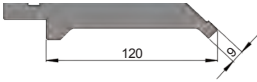
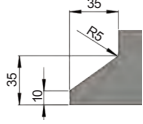
Angle	Radii	Code	Length	Price	Tool #804 AFH - 100 t/m
86°	R0.6	8048061	835mm	£292	R1.5 & R3.0 also available in 86° only  9mm tip  Ear tonnage = 45 t/m
		8048062	415mm	£165	
		8048063	Sec	£419	
88°		8047061	835mm	£292	
		8047062	415mm	£165	
		8047063	Sec	£419	
90°		8049061	835mm	£292	
		8049062	415mm	£165	
		8049063	Sec	£419	

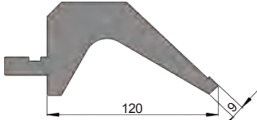
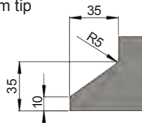
Angle	Radii	Code	Length	Price	Tool #847 AFH - 50 t/m
86°	R0.6	8478061	835mm	£717	R1.5 & R3.0 also available in 86° only  9mm tip  Ear tonnage = 45 t/m
		8478062	415mm	£429	
		8478063	Sec	£1,099	
88°		8477061	835mm	£717	
		8477062	415mm	£429	
		8477063	Sec	£1,099	
90°		8479061	835mm	£717	
		8479062	415mm	£429	
		8479063	Sec	£1,099	

AFH Punches H=120

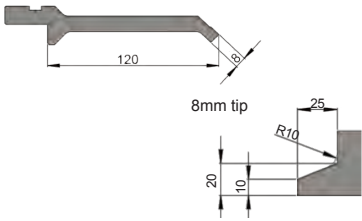
Angle	Radii	Code	Length	Price	Tool #820 AFH - 50 t/m
86°	R0.6	8208061	835mm	£474	<p>R1.5 also available in 86° only</p>  <p>8mm tip</p> <p>Ear tonnage = 20 t/m</p>
		8208062	415mm	£281	
		8208063	Sec	£735	
88°		8207061	835mm	£474	
		8207062	415mm	£281	
		8207063	Sec	£735	

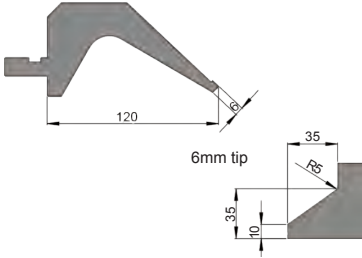
Angle	Radii	Code	Length	Price	Tool #846 AFH - 45 t/m
86°	R0.6	8468061	835mm	£731	 <p>6mm tip</p> <p>Ear tonnage = 35 t/m</p>
		8468062	415mm	£437	
		8468063	Sec	£1,120	
88°		8467061	835mm	£731	
		8467062	415mm	£437	
		8467063	Sec	£1,120	

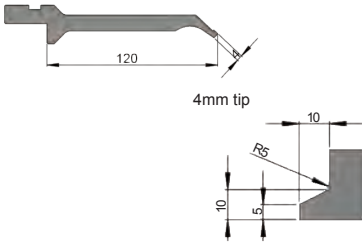
Angle	Radii	Code	Length	Price	Tool #817 AFH - 30 t/m
86°	R0.6	8178061	835mm	£453	 <p>4mm tip</p> <p>Ear tonnage = 15 t/m</p>
		8178062	415mm	£273	
		8178063	Sec	£697	
88°		8177061	835mm	£453	
		8177062	415mm	£273	
		8177063	Sec	£697	

AFH Punches H=120

Angle	Radii	Code	Length	Price	Tool #814 AFH - 45 t/m
30°	R0.6	8143061	835mm	£444	 <p>Ear tonnage = 12 t/m</p>
		8143062	415mm	£308	
		8143063	Sec	£644	

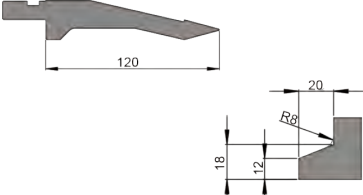
Angle	Radii	Code	Length	Price	Tool #831 AFH - 100 t/m
26°	R0.6	8312061	835mm	£509	<p>R1.5, R3.0 & R4.0 also available in 30° only</p>  <p>Ear tonnage = 30 t/m</p>
		8312062	415mm	£261	
		8312063	Sec	£668	
30°	R0.6	8313061	835mm	£454	
		8313062	415mm	£233	
		8313063	Sec	£596	

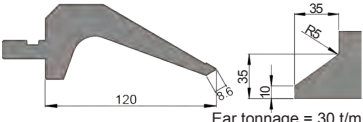
Angle	Radii	Code	Length	Price	Tool #841 AFH - 70 t/m
60°	R0.6	8416061	835mm	£598	<p>R1.5 also available</p>  <p>Ear tonnage = 30 t/m</p>
		8416062	415mm	£333	
		8416063	Sec	£832	

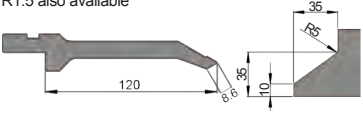
Angle	Radii	Code	Length	Price	Tool #840 AFH - 70 t/m
60°	R0.6	8406061	835mm	£372	<p>R1.5 also available</p>  <p>Ear tonnage = 30 t/m</p>
		8406062	415mm	£222	
		8406063	Sec	£548	

AFH Punches H=120

Angle	Radii	Code	Length	Price	Tool #803 AFH - 100 t/m
60°	R6.0	8036601	835mm	£395	
		8036602	415mm	£219	
		8036603	Sec	£556	
	R5.0	8036501	835mm	£494	
		8036502	415mm	£274	
		8036503	Sec	£695	

Angle	Radii	Code	Length	Price	Tool #822 AFH - 100 t/m
Flattening		8220001	835mm	£466	
		8220002	415mm	£266	
		8220003	Sec (no ears)	£686	

Example of Staged Flattening

AFH Punches H=90

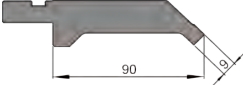
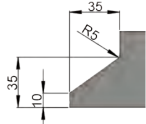
Angle	Radii	Code	Length	Price	Tool #704 AFH - 100 t/m
86°	R0.6	7048061	835mm	£298	<p>R1.5 & R3.0 also available in 86° only</p>  <p>9mm tip</p>  <p>Ear tonnage = 45 t/m</p> <p>Was #0S01 (86°) Was #0S02 (90°)</p>
		7048062	415mm	£173	
		7048063	Sec	£414	
88°		7047061	835mm	£298	
		7047062	415mm	£173	
		7047063	Sec	£414	
90°		7049061	835mm	£298	
		7049062	415mm	£173	
		7049063	Sec	£414	

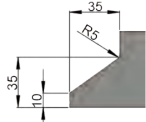
Angle	Radii	Code	Length	Price	Tool #747 AFH - 80 t/m
86°	R0.6	7478061	835mm	£398	<p>R1.5 & R3.0 also available in 86° only</p>  <p>9mm tip</p>  <p>Ear tonnage = 45 t/m</p> <p>Was #452 (88°)</p>
		7478062	415mm	£210	
		7478063	Sec	£531	
88°		7477061	835mm	£398	
		7477062	415mm	£210	
		7477063	Sec	£531	
90°		7479061	835mm	£398	
		7479062	415mm	£210	
		7479063	Sec	£531	

AFH Punches H=90

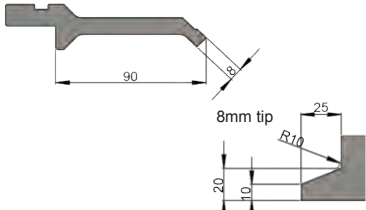
Angle	Radii	Code	Length	Price	Tool #720 AFH - 50 t/m
86°	R0.6	7208061	835mm	£446	 <p>R1.5 also available in 86° only</p> <p>Was #0S03 (86°)</p> <p>Ear tonnage = 20 t/m</p>
		7208062	415mm	£264	
		7208063	Sec	£710	
88°		7207061	835mm	£446	
		7207062	415mm	£264	
		7207063	Sec	£710	

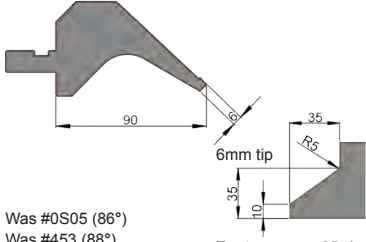
Angle	Radii	Code	Length	Price	Tool #746 AFH - 55 t/m
86°	R0.6	7468061	835mm	£452	 <p>Was #0S05 (86°)</p> <p>Was #453 (88°)</p> <p>Ear tonnage = 35 t/m</p>
		7468062	415mm	£244	
		7468063	Sec	£576	
88°		7467061	835mm	£452	
		7467062	415mm	£244	
		7467063	Sec	£576	

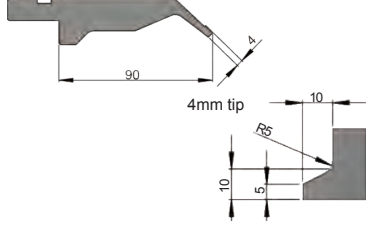
Angle	Radii	Code	Length	Price	Tool #717 AFH - 20 t/m
86°	R0.6	7178061	835mm	£457	 <p>Ear tonnage = 15 t/m</p>
		7178062	415mm	£265	
		7178063	Sec	£621	
88°		7177061	835mm	£457	
		7177062	415mm	£265	
		7177063	Sec	£621	

AFH Punches H=90

Angle	Radii	Code	Length	Price	Tool #731 AFH - 100 t/m
30°	R0.6	7313061	835mm	£386	<p>R1.5 & R3.0 also available</p> <p>Ear tonnage = 30 t/m</p>
		7313062	415mm	£220	
		7313063	Sec	£493	

Angle	Radii	Code	Length	Price	Tool #713 AFH - 45 t/m
30°	R0.6	7133061	835mm	£411	<p>Ear tonnage = 12 t/m</p>
		7133062	415mm	£237	
		7133063	Sec	£615	

AFH Punches H=160

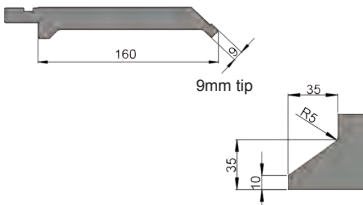
Angle	Radii	Code	Length	Price	Tool #904 AFH - 100 t/m
86°	R0.6	9048061	835mm	£881	<p>R1.5 & R3.0 also available in 86° only</p>  <p>9mm tip</p> <p>Ear tonnage = 45 t/m</p>
		9048062	415mm	£527	
		9048063	Sec	£1,075	
88°		9047061	835mm	£881	
		9047062	415mm	£527	
		9047063	Sec	£1,075	

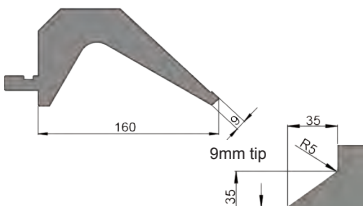
Angle	Radii	Code	Length	Price	Tool #947 AFH - 50 t/m
86°	R0.6	9478061	835mm	£1,248	<p>R1.5 & R3.0 also available in 86° only</p>  <p>9mm tip</p> <p>Ear tonnage = 45 t/m</p>
		9478062	415mm	£736	
		9478063	Sec	£1,586	
88°		9477061	835mm	£1,248	
		9477062	415mm	£736	
		9477063	Sec	£1,586	

Was #472 (88°)

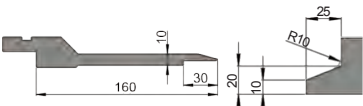
Angle	Radii	Code	Length	Price	Tool #914 AFH - 45 t/m
30°	R0.6	9143061	835mm	£1,030	 <p>Ear tonnage = 12 t/m</p>
		9143062	415mm	£575	
		9143063	Sec	£1,297	

Punches H=70

Angle	Radii	Code	Length	Price	Tool #604 - 100 t/m
88°	R0.6	6047061	835mm	£185	<p>R0.2, R0.8, R1.5 & R3.0 also available in 88° R0.2 also available in 90°</p> <p>Was #4 (88°) Was #16 (90°)</p> <p>Ear tonnage = 45 t/m</p>
		6047062	415mm	£107	
		Sec	£278		
90°		6049061	835mm	£185	
		6049062	415mm	£107	
		Sec	£278		

Angle	Radii	Code	Length	Price	Tool #617 - 30 t/m
88°	R0.6	6177061	835mm	£349	<p>R0.2 & R0.8 also available in 88° R0.2 also available in 90°</p> <p>Was #117 (88°) Was #116 (90°)</p> <p>Ear tonnage = 15 t/m</p>
		6177062	415mm	£200	
		Sec	£523		
90°		6179061	835mm	£349	
		6179062	415mm	£200	
		Sec	£523		

Angle	Radii	Code	Length	Price	Tool #640 - 100 t/m
60°	R0.8	6406081	835mm	£320	<p>Was #704</p> <p>Ear tonnage = 30 t/m</p>
		6406082	415mm	£227	
		Sec	£460		

Punches H=70

Angle	Radii	Code	Length	Price	Tool #640 - 100 t/m
60°	R2.0	6406201	835mm	£320	
		6406202	415mm	£227	
		6406203	Sec	£460	

Angle	Radii	Code	Length	Price	Tool #603 - 100 t/m
60°	R6.0	6036601	835mm	£336	
		6036602	415mm	£189	
		6036603	Sec	£504	

Angle	Radii	Code	Length	Price	Tool #631 - 100 t/m
30°	R0.52	6313051	835mm	£255	
		6313052	415mm	£151	
		6313053	Sec	£375	

Angle	Radii	Code	Length	Price	Tool #622 - 100 t/m
Flattening		6220001	835mm	£408	
		6220002	415mm	£228	

Radius Punches

	Radii	Code	Length	Price	Tool #0150 Holder - 100 t/m*
		0150001	830mm	£215	 <p>Was #15</p>
		0150002	412mm	£129	

	Radii	Code	Length	Price	Tool #17 - 100 t/m
	R7.0	0170071	835mm	£106	
		0170072	415mm	£59	

	Radii	Code	Length	Price	Tool #17 - 100 t/m
	R8.0	0170081	835mm	£113	
		0170082	415mm	£61	

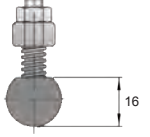
	Radii	Code	Length	Price	Tool #17 - 100 t/m
	R9.0	0170091	835mm	£124	
		0170092	415mm	£66	

	Radii	Code	Length	Price	Tool #17 - 100 t/m
	R10.0	0170101	835mm	£63	
		0170102	415mm	£40	

* For higher Holder, please call the Tooling Hotline

Radius Punches

	Radii	Code	Length	Price	Tool #17 - 100 t/m
	R11.0	0170111	835mm	£153	
		0170112	415mm	£83	

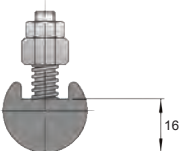
	Radii	Code	Length	Price	Tool #17 - 100 t/m
	R12.5	0170121	835mm	£165	
		0170122	415mm	£91	

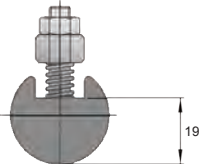
	Radii	Code	Length	Price	Tool #17 - 100 t/m
	R14.0	0170141	835mm	£173	
		0170142	415mm	£95	

	Radii	Code	Length	Price	Tool #17 - 100 t/m
	R15.0	0170151	835mm	£89	
		0170152	415mm	£49	

	Radii	Code	Length	Price	Tool #17 - 100 t/m
	R16.0	0170161	835mm	£189	
		0170162	415mm	£106	

Radius Punches

	Radii	Code	Length	Price	Tool #17 - 100 t/m
	R17.5	0170171	835mm	£90	
		0170172	415mm	£57	

	Radii	Code	Length	Price	Tool #17 - 100 t/m
	R20.0	0170201	835mm	£112	
		0170202	415mm	£69	

	Radii	Code	Length	Price	Tool #17 - 100 t/m
	R22.5	0170221	835mm	£230	
		0170222	415mm	£139	

	Radii	Code	Length	Price	Tool #17 - 100 t/m
	R25.0	0170251	835mm	£128	
		0170252	415mm	£77	

	Radii	Code	Length	Price	Tool #17 - 100 t/m
	R30.0	0170301	835mm	£158	
		0170302	415mm	£91	

Radius Punches

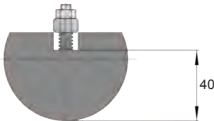
	Radii	Code	Length	Price	Tool #17 - 100 t/m
	R35.0	0170351	835mm	£385	
		0170352	415mm	£230	

	Radii	Code	Length	Price	Tool #17 - 100 t/m
	R40.0	0170401	835mm	£417	
		0170402	415mm	£246	

	Radii	Code	Length	Price	Tool #17 - 100 t/m
	R45.0	0170451	835mm	£474	
		0170452	415mm	£274	

	Radii	Code	Length	Price	Tool #17 - 100 t/m
	R50.0	0170501	835mm	£490	
		0170502	415mm	£281	

Colour Radius Punches

	Radii	Code	Length	Price	Tool #CR30 - 50 t/m
		730001	835mm	£814	
		730002	415mm	£602	
		730801	Sec*	£1,250	

	Radii	Code	Length	Price	Yellow
	R12.5	03YE01	835mm	£74	
		03YE02	415mm	£60	
		03BYE1	Sec*	£103	

	Radii	Code	Length	Price	Red
	R15.0	03RE01	835mm	£74	
		03RE02	415mm	£60	
		03BRE1	Sec*	£103	

	Radii	Code	Length	Price	Black
	R17.5	03BR01	835mm	£74	
		03BR02	415mm	£60	
		03BBR1	Sec*	£103	

	Radii	Code	Length	Price	Light Blue
	R20.0	03SB01	835mm	£74	
		03SB02	415mm	£60	
		03BSB1	Sec*	£103	

Colour Radius Punches

	Radii	Code	Length	Price	Green
	R22.5	03GR01	835mm	£74	
		03GR02	415mm	£60	
		03BGR1	Sec*	£103	

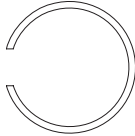
	Radii	Code	Length	Price	White
	R25.0	03HD01	835mm	£74	
		03HD02	415mm	£60	
		03BHD1	Sec*	£103	

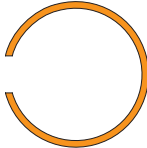
	Radii	Code	Length	Price	Orange
	R27.5	03OR01	835mm	£74	
		03OR02	415mm	£60	
		03BOR1	Sec*	£103	

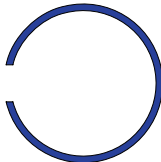
	Radii	Code	Length	Price	Dark Blue
	R30.0	03BU01	835mm	£74	
		03BU02	415mm	£60	
		03BBU1	Sec*	£103	

* Sec length: 25, 40, 50, 100, 120, 200, 300 = 835mm

Multi-Radius Punches

	Radii	Code	Length	Price	Tool #91 Holder
		691001	835mm	£834	 <p>Ear Type</p>
		691002	415mm	£561	
		691801	Sec*	£971	

	Radii	Code	Length	Price	Tool #90
	R3.0	090301	835mm	£183	
		090302	415mm	£128	
		090831	Sec*	£200	

	Radii	Code	Length	Price	Tool #90
	R4.0	090401	835mm	£183	
		090402	415mm	£128	
		090841	Sec*	£200	

	Radii	Code	Length	Price	Tool #90
	R5.0	090501	835mm	£183	
		090502	415mm	£128	
		090851	Sec*	£200	

	Radii	Code	Length	Price	Tool #90
	R6.0	090601	835mm	£183	
		090602	415mm	£128	
		090861	Sec*	£200	

Multi-Radius Punches

	Radii	Code	Length	Price	Tool #90
	R8.0	090801	835mm	£183	
		090802	415mm	£128	
		090881	Sec*	£200	

	Radii	Code	Length	Price	Tool #90
	R10.0	090101	835mm	£183	
		090102	415mm	£128	
		090811	Sec*	£200	

* Sec length: 100 (ear), 20, 25, 30, 35, 40, 50, 70, 165, 200, 100 (ear) = 835mm

Burring Punches

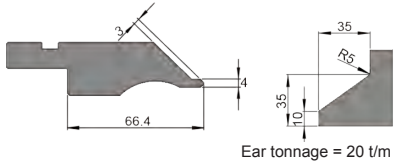
Angle	Radii	Code	Length	Price	Tool #486 - 40 t/m
88°	R0.6	604861	835mm	£389	
		604862	415mm	£238	
		648861	Sec*	£536	

Angle	Radii	Code	Length	Price	Tool #496 - 80 t/m
88°	R0.6	604961	835mm	£357	
		604962	415mm	£207	
		648961	Sec*	£467	

* Sec length: 100 (ear), 10, 15, 20, 40, 50, 200, 300, 100 (ear) = 835mm

Burring Punches

Components with burred or extruded holes can be formed easily without interference

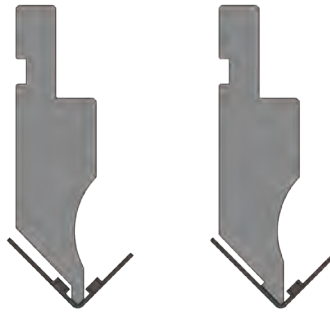

Special Punch Holders

Machine Type	Code	Length	Price	Tool #225
Machines with open height of 300mm	225002	415mm	£161	

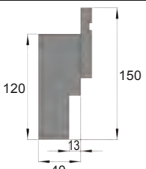

Machine Type	Code	Length	Price	Tool #227
Machines with open height of 370mm or more	227002	415mm	£294	



Above holders to be used in place of standard distance pieces when the required bend tonnage exceeds 100 t/m

Flattening

Angle	Radii	Code	Length	Price	Tool #020
Flattening		0200001	835mm	£93	
		0200002	415mm	£55	

Clamps

Code	Price	AGRIP M	
905200	£530		

Code	Price	SGRIP	SGRIP Rear Clamp Assy
903100 (SGRIP)	£349		
903300 (Rear Clamp)	£96		

Code	Price	Fast Clamp
980000	£79	

Note: Requires 2-off C10549 (Bolt) & 2-off C52487 (Spring)
Please ask for prices

Code	Price	Quick Release
C58621	POA	

Note: Includes bolts and springs

Code	Price	Standard
961000	£33	

Note: Requires 2-off C10549 (Bolt) & 2-off C52487 (Spring)
Please ask for prices

Distance Pieces

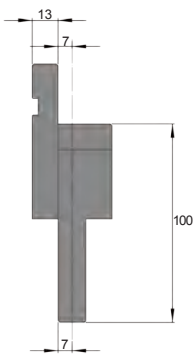
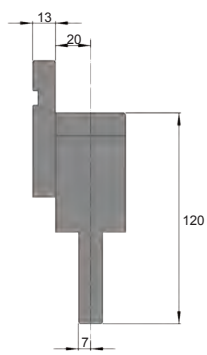
Code	Price	ZI Standard	ZII Standard
C58652 ZI	POA		
C58654 ZII	POA		

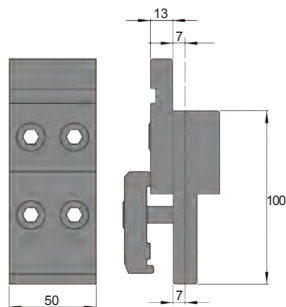
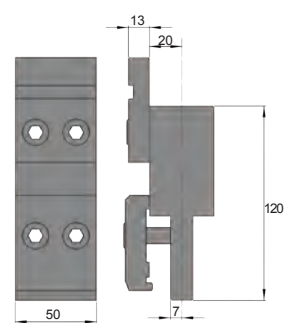
Code	Price	ZI Narrow	ZII Narrow
912000 ZI	£272		
913000 ZII	£272		

Press Brake
Tooling

AFH 1V Dies V=4

Angle	V-Size	Code	Length	Price	Tool #0848 AFH - 75 t/m
86°	V4	0848101	835mm	£464	
		0848102	415mm	£254	
		0848103	Sec	£564	

Angle	V-Size	Code	Length	Price	Tool #0847 AFH - 75 t/m
88°	V4	0847101	835mm	£464	
		0847102	415mm	£254	
		0847103	Sec	£564	

Angle	V-Size	Code	Length	Price	Tool #0849 AFH - 75 t/m
90°	V4	0849101	835mm	£464	
		0849102	415mm	£254	
		0849103	Sec	£564	

Angle	V-Size	Code	Length	Price	Tool #1848 STAGED - 75 t/m
86°	V4	1848101	835mm	£464	
		1848102	415mm	£254	
		1848103	Sec	£564	

Was #OS84

AFH 1V Dies V=6

Angle	V-Size	Code	Length	Price	Tool #0708 AFH - 80 t/m
86°	V6	0708151	835mm	£290	
		0708152	415mm	£163	
		0708153	Sec	£350	

Angle	V-Size	Code	Length	Price	Tool #0707 AFH - 80 t/m
88°	V6	0707151	835mm	£290	
		0707152	415mm	£163	
		0707153	Sec	£350	

Angle	V-Size	Code	Length	Price	Tool #0709 AFH - 80 t/m
90°	V6	0709151	835mm	£290	
		0709152	415mm	£163	
		0709153	Sec	£350	

Was #70

Angle	V-Size	Code	Length	Price	Tool #0703 AFH - 50 t/m
30°	V6	0703101	835mm	£464	
		0703102	415mm	£254	
		0703103	Sec	£564	

Was #14006

Angle	V-Size	Code	Length	Price	Tool #0706 AFH - 38 t/m
60°	V6	0706061	835mm	£407	
		0706062	415mm	£224	
		0706063	Sec	£492	

Was #170

AFH 1V Dies V=6

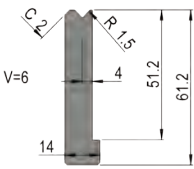
Angle	V-Size	Code	Length	Price	Tool #1708 STAGED - 80 t/m
86°	V6	1708151	835mm	£431	
		1708152	415mm	£241	
		1708153	Sec	£609	

Angle	V-Size	Code	Length	Price	Tool #1703 STAGED - 40 t/m
30°	V6	1703101	835mm	£550	
		1703102	415mm	£308	
		1703103	Sec	£728	

AFH 1V Dies V=8

Angle	V-Size	Code	Length	Price	Tool #0718 AFH - 90 t/m
86°	V8	0718151	835mm	£290	
		0718152	415mm	£163	
		0718153	Sec	£350	

Angle	V-Size	Code	Length	Price	Tool #0717 AFH - 90 t/m
88°	V8	0717151	835mm	£290	
		0717152	415mm	£163	
		0717153	Sec	£350	

AFH 1V Dies V=8

Angle	V-Size	Code	Length	Price	Tool #0719 AFH - 90 t/m
90°	V8	0719151	835mm	£290	 <p>Was #71</p>
		0719152	415mm	£163	
		0719153	Sec	£350	

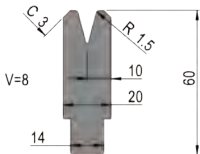
Angle	V-Size	Code	Length	Price	Tool #0713 AFH - 60 t/m
30°	V8	0713151	835mm	£464	 <p>Was #71</p>
		0713152	415mm	£254	
		0713153	Sec	£564	

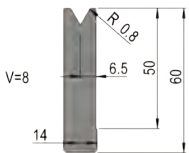
Angle	V-Size	Code	Length	Price	Tool #0716 AFH - 45 t/m
60°	V8	0716081	835mm	£407	 <p>Was #171</p>
		0716082	415mm	£224	
		0716083	Sec	£492	

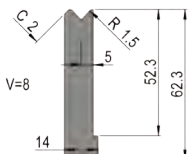
Angle	V-Size	Code	Length	Price	Tool #1718 STAGED - 90 t/m
86°	V8	1718151	835mm	£431	 <p>Was #OS71</p>
		1718152	415mm	£241	
		1718153	Sec	£609	

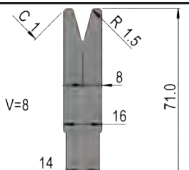
Angle	V-Size	Code	Length	Price	Tool #1713 STAGED - 50 t/m
30°	V8	1713151	835mm	£550	 <p>Was #OS713</p>
		1713152	415mm	£308	
		1713153	Sec	£728	

AFH 1V Dies V=10

Angle	V-Size	Code	Length	Price	Tool #0728 AFH - 100 t/m
86°	V10	0728201	835mm	£290	
		0728202	415mm	£163	
		0728203	Sec	£350	

Angle	V-Size	Code	Length	Price	Tool #0727 AFH - 100 t/m
88°	V10	0727201	835mm	£290	
		0727202	415mm	£163	
		0727203	Sec	£350	

Angle	V-Size	Code	Length	Price	Tool #0729 AFH - 100 t/m
90°	V10	0729201	835mm	£290	
		0729202	415mm	£163	
		0729203	Sec	£350	

Angle	V-Size	Code	Length	Price	Tool #0723 AFH - 70 t/m
30°	V10	0723201	835mm	£464	
		0723202	415mm	£254	
		0723203	Sec	£564	

Angle	V-Size	Code	Length	Price	Tool #0726 AFH - 55 t/m
60°	V10	0726101	835mm	£407	
		0726102	415mm	£224	
		0726103	Sec	£492	

Press Brake Tooling

AFH 1V Dies V=10

Angle	V-Size	Code	Length	Price	Tool #1728 STAGED - 100 t/m
86°	V10	1728201	835mm	£431	
		1728202	415mm	£241	
		1728203	Sec	£609	

Angle	V-Size	Code	Length	Price	Tool #1723 STAGED - 60 t/m
30°	V10	1723201	835mm	£573	
		1723202	415mm	£321	
		1723203	Sec	£750	

AFH 1V Dies V=12

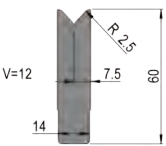
Angle	V-Size	Code	Length	Price	Tool #0748 AFH - 100 t/m
86°	V12	0748251	835mm	£290	
		0748252	415mm	£163	
		0748253	Sec	£350	

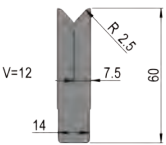
Angle	V-Size	Code	Length	Price	Tool #0747 AFH - 100 t/m
88°	V12	0747251	835mm	£290	
		0747252	415mm	£163	
		0747253	Sec	£350	

AFH 1V Dies V=12

Angle	V-Size	Code	Length	Price	Tool #0749 AFH - 100 t/m
90°	V12	0749251	835mm	£290	
		0749252	415mm	£163	
		0749253	Sec	£350	

Angle	V-Size	Code	Length	Price	Tool #0743 AFH - 80 t/m
30°	V12	0743251	835mm	£464	
		0743252	415mm	£254	
		0743253	Sec	£564	

Angle	V-Size	Code	Length	Price	Tool #0746 AFH - 55 t/m
60°	V12	0746121	835mm	£407	
		0746122	415mm	£224	
		0746123	Sec	£492	

Angle	V-Size	Code	Length	Price	Tool #1748 STAGED - 100 t/m
86°	V12	1748251	835mm	£467	
		1748252	415mm	£262	
		1748253	Sec	£645	

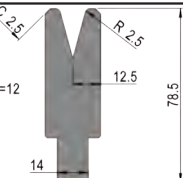
Angle	V-Size	Code	Length	Price	Tool #1743 STAGED - 70 t/m
30°	V12	1743251	835mm	£573	
		1743252	415mm	£321	
		1743253	Sec	£750	

AFH 1V Dies V=14

Angle	V-Size	Code	Length	Price	Tool #0768 AFH - 100 t/m
86°	V14	0768251	835mm	£351	
		0768252	415mm	£192	
		0768253	Sec	£400	

Angle	V-Size	Code	Length	Price	Tool #0767 AFH - 100 t/m
88°	V14	0767251	835mm	£351	
		0767252	415mm	£192	
		0767253	Sec	£400	

Was #76

AFH 1V Dies V=16

Angle	V-Size	Code	Length	Price	Tool #0778 AFH - 100 t/m
86°	V16	0778251	835mm	£436	
		0778252	415mm	£255	
		0778253	Sec	£512	

Angle	V-Size	Code	Length	Price	Tool #0777 AFH - 100 t/m
88°	V16	0777251	835mm	£436	
		0777252	415mm	£255	
		0777253	Sec	£512	

Was #77

AFH 1V Dies V=16

Angle	V-Size	Code	Length	Price	Tool #0773 AFH - 60 t/m
30°	V16	0773301	835mm	£568	
		0773302	415mm	£335	
		0773303	Sec	£687	

Angle	V-Size	Code	Length	Price	Tool #0776 AFH - 65 t/m
60°	V16	0776161	835mm	£511	
		0776162	415mm	£304	
		0776163	Sec	£616	

Angle	V-Size	Code	Length	Price	Tool #1778 STAGED - 100 t/m
86°	V16	1778251	835mm	£518	
		1778252	415mm	£290	
		1778253	Sec	£694	

AFH 1V Dies V=18

Angle	V-Size	Code	Length	Price	Tool #0788 AFH - 100 t/m
86°	V18	0788251	835mm	£491	
		0788252	415mm	£293	
		0788253	Sec	£592	

AFH 1V Dies V=18

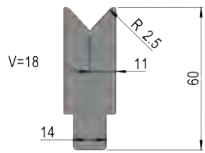
Angle	V-Size	Code	Length	Price	Tool #0787 AFH - 100 t/m
88°	V18	0787251	835mm	£491	
		0787252	415mm	£293	
		0787253	Sec	£592	

AFH 1V Dies V=20

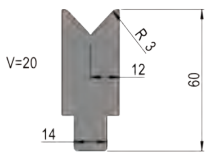
Angle	V-Size	Code	Length	Price	Tool #0798 AFH - 100 t/m
86°	V20	0798301	835mm	£505	
		0798302	415mm	£300	
		0798303	Sec	£610	

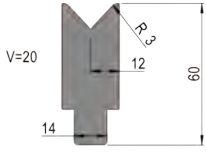
Angle	V-Size	Code	Length	Price	Tool #0797 AFH - 100 t/m
88°	V20	0797301	835mm	£505	
		0797302	415mm	£300	
		0797303	Sec	£610	

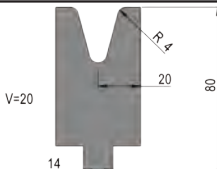
Angle	V-Size	Code	Length	Price	Tool #0793 - 60 t/m
30°	V20	0793401	835mm	£596	
		0793402	415mm	£350	
		0793403	Sec	£723	

AFH 1V Dies V=20

Angle	V-Size	Code	Length	Price	Tool #0796 AFH – 85 t/m
60°	V20	0796201	835mm	£541	 <p>Was #179</p>
		0796202	415mm	£320	
		0796203	Sec	£652	

Angle	V-Size	Code	Length	Price	Tool #1798 STAGED - 100 t/m
86°	V20	1798301	835mm	£530	 <p>Was #OS79</p>
		1798302	415mm	£317	
		1798303	Sec	£710	

AFH 1V Dies V=25

Angle	V-Size	Code	Length	Price	Tool #0828 AFH - 100 t/m
86°	V25	0828301	835mm	£520	
		0828302	415mm	£308	
		0828303	Sec	£627	

Angle	V-Size	Code	Length	Price	Tool #0827 AFH - 100 t/m
88°	V25	0827301	835mm	£520	 <p>Was #82</p>
		0827302	415mm	£308	
		0827303	Sec	£627	

AFH 1V Dies V=25

Angle	V-Size	Code	Length	Price	Tool #0823 – 60 t/m
30°	V25	0823401	835mm	£616	
		0823402	415mm	£363	
		0823403	Sec	£747	

Angle	V-Size	Code	Length	Price	Tool #0826 AFH – 85 t/m
60°	V25	0826251	835mm	£558	
		0826252	415mm	£331	
		0826253	Sec	£676	

Angle	V-Size	Code	Length	Price	Tool #1828 STAGED – 100 t/m
86°	V25	1828301	835mm	£568	
		1828302	415mm	£318	
		1828303	Sec	£746	

AFH 1V Dies V=32 & V=40

Angle	V-Size	Code	Length	Price	Tool #0874 (V32) & Tool #0884 (V40) – 100 t/m
84°	V32	0874401	835mm	£658	
		0874402	415mm	£390	
		0874403	Sec	£767	
	V40	0884401	835mm	£737	
		0884402	415mm	£478	
		0884403	Sec	£867	

2V Dies Reversible 88°/90°

Angle	V-Size	Code	Length	Price	Tool #501704 / #501904 – 60 t/m
88°	V4 & V7	5017041	835mm	£296	
		5017042	415mm	£165	
		5017043	Sec	£398	
90°		5019041	835mm	£296	
		5019042	415mm	£165	
		5019043	Sec	£398	

Angle	V-Size	Code	Length	Price	Tool #507704 / #507904 – 65 t/m
88°	V5 & V9	5077041	835mm	£296	
		5077042	415mm	£165	
		5077043	Sec	£398	
90°		5079041	835mm	£296	
		5079042	415mm	£165	
		5079043	Sec	£398	

Angle	V-Size	Code	Length	Price	Tool #502704 / #502904 – 70 t/m
88°	V6 & V10	5027041	835mm	£296	
		5027042	415mm	£165	
		5027043	Sec	£398	
90°		5029041	835mm	£296	
		5029042	415mm	£165	
		5029043	Sec	£398	

2V Dies Reversible 88°/90°

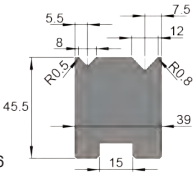
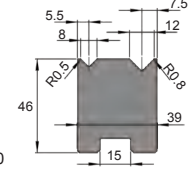
Angle	V-Size	Code	Length	Price	Tool #503705 / #503905 – 70 t/m	
88°	V8 & V12	5037051	835mm	£296	 <p>Was #50396</p>	
		5037052	415mm	£165		
		5037053	Sec	£398		
90°		5039051	835mm	£296		 <p>Was #50390</p>
		5039052	415mm	£165		
		5039053	Sec	£398		

Angle	V-Size	Code	Length	Price	Tool #504705 – 100 t/m
88°	V14 & V18	5047051	835mm	£296	 <p>Was #50490</p>
		5047052	415mm	£165	
		5047053	Sec	£398	

Angle	V-Size	Code	Length	Price	Tool #505705 – 100 t/m
88°	V12 & V20	5057051	835mm	£296	 <p>Was #50590</p>
		5057052	415mm	£165	
		5057053	Sec	£398	

Angle	V-Size	Code	Length	Price	Tool #506708 – 100 t/m
88°	V16 & V25	5067081	835mm	£296	 <p>Was #50690</p>
		5067082	415mm	£165	
		5067083	Sec	£398	

2V Dies Reversible 60°/30°

Angle	V-Size	Code	Length	Price	Tool #502606 – 60 t/m
60°	V6 & V10	5026061	835mm	£386	 <p>Was #50260</p>
		5026062	415mm	£215	
		5026063	Sec	£522	

Angle	V-Size	Code	Length	Price	Tool #503608 – 60 t/m
60°	V8 & V12	5036081	835mm	£420	 <p>Was #50360</p>
		5036082	415mm	£236	
		5036083	Sec	£567	

Angle	V-Size	Code	Length	Price	Tool #506616 – 60 t/m
60°	V16 & V25	5066161	835mm	£503	 <p>Was #50660</p>
		5066162	415mm	£282	
		5066163	Sec	£680	

Angle	V-Size	Code	Length	Price	Tool #339310 – 40 t/m
30°	V8 & V12	3393101	835mm	£387	 <p>Was #339</p>
		3393102	415mm	£256	
		3393103	Sec	£495	

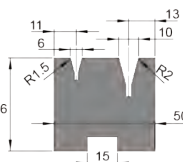
Angle	V-Size	Code	Length	Price	Tool #337315 – 26 t/m
30°	V6 & V10	3373151	835mm	£503	 <p>Was #33706</p>
		3373152	415mm	£282	
		3373153	Sec	£680	

Heavy Duty 1V

Angle	V-Size	Code	Length	Price	Tool #35 – 100 t/m
85°	V32	035001	835mm	£206	
		035002	415mm	£138	

Angle	V-Size	Code	Length	Price	Tool #36 – 100 t/m
85°	V40	036001	835mm	£210	
		036002	415mm	£140	

Angle	V-Size	Code	Length	Price	Tool #37 – 100 t/m
85°	V50	037001	835mm	£221	
		037002	415mm	£145	

Angle	V-Size	Code	Length	Price	Tool #0385 – 100 t/m
85°	V63	0385501	835mm	£478	
		0385502	415mm	£268	

Was #38

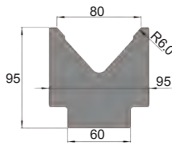
Angle	V-Size	Code	Length	Price	Tool #13 – 100 t/m
85°	V80	013601	835mm	£606	
		013602	415mm	£363	

Heavy Duty 1V

Angle	V-Size	Code	Length	Price	Tool #18 – 100 t/m
85°	V100	018601	835mm	£809	
		018602	415mm	£494	

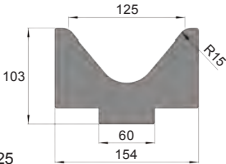
Angle	V-Size	Code	Length	Price	Tool #039015 – 100 t/m
80°	V125	0390151	835mm	£1,157	
		0390152	415mm	£695	

Was #Z0125

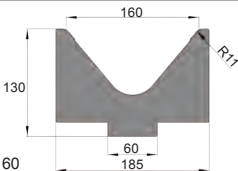
Angle	V-Size	Code	Length	Price	Tool #014011 – 100 t/m
80°	V160	0140111	835mm	£1,363	
		0140112	415mm	£914	

Was #Z0160

Heavy Duty 1V - Acute

Angle	V-Size	Code	Length	Price	Tool #340 – 80 t/m
30°	V18	340001	835mm	£273	
		340002	415mm	£158	

Angle	V-Size	Code	Length	Price	Tool #341 – 60 t/m
30°	V25	341001	835mm	£294	
		341002	415mm	£179	

Angle	V-Size	Code	Length	Price	Tool #342 – 40 t/m
45°	V32	342001	835mm	£294	
		342002	415mm	£179	

Angle	V-Size	Code	Length	Price	Tool #343150 – 70 t/m
45°	V40	3431501	835mm	£411	
		3431502	415mm	£230	

Was #343

Angle	V-Size	Code	Length	Price	Tool #038650 – 100 t/m
60°	V63	0386501	835mm	£950	
		0386502	415mm	£531	

Was #03806

Heavy Duty 1V - Acute

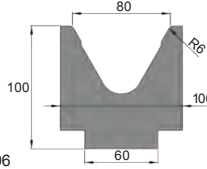
Angle	V-Size	Code	Length	Price	Tool #013660 – 100 t/m
60°	V80	0136601	835mm	£1,193	
		0136602	415mm	£658	

Angle	V-Size	Code	Length	Price	Tool #0871 – 100 t/m
45°	V32	0871501	835mm	£658	
		0871502	415mm	£390	

Angle	V-Size	Code	Length	Price	Tool #0881 – 100 t/m
45°	V40	0881501	835mm	£737	
		0881502	415mm	£478	

Other Dies

	V-Size	Code	Length	Price	Tool #0129 – 100 t/m
	V6, V10, V18	0129001	835mm	£203	
		0129002	415mm	£122	

Polycarbonate Dies

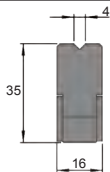
Angle	V-Size	Code	Length	Price	Tool #331 – 32 t/m
88°	V4	331881	835mm	£168	
		331882	415mm	£104	

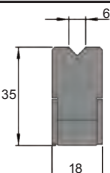
Angle	V-Size	Code	Length	Price	Tool #332 – 32 t/m
88°	V6	332881	835mm	£168	
		332882	415mm	£104	

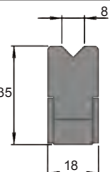
Angle	V-Size	Code	Length	Price	Tool #333 – 32 t/m
88°	V8	333001	835mm	£168	
		333002	415mm	£104	

Angle	V-Size	Code	Length	Price	Tool #334 – 32 t/m
88°	V10	334001	835mm	£168	
		334002	415mm	£104	

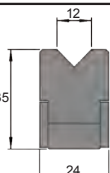
Angle	V-Size	Code	Length	Price	Tool #335 – 32 t/m
88°	V12	335001	835mm	£168	
		335002	415mm	£104	

Polycarbonate Dies - Radius Bend

Angle	V-Size	Code	Length	Price	Tool #351 – 50 t/m
70°	V32	351001	835mm	£406	
		351002	415mm	£236	

Angle	V-Size	Code	Length	Price	Tool #361 – 50 t/m
70°	V40	361001	835mm	£438	
		361002	415mm	£252	

Angle	V-Size	Code	Length	Price	Tool #371 – 50 t/m
70°	V50	371001	835mm	£483	
		371002	415mm	£273	

Press Brake Tooling

Specification

		V=32			V=40			V=50		
		Mild Steel	Stainless	Aluminium	Mild Steel	Stainless	Aluminium	Mild Steel	Stainless	Aluminium
Radius	thk	0.4~2.3	0.4~1.5	0.4~3.0	0.6~2.3	0.6~1.5	0.6~3.0	0.8~2.3	0.8~1.5	0.8~3.0
6.0		✓	✓	✓						
8.0		✓	✓	✓	✓	✓	✓			
10.0		✓	✓	✓	✓	✓	✓	✓	✓	✓
12.5		✓	✓	✓	✓	✓	✓	✓	✓	✓
15.0			✓		✓	✓	✓	✓	✓	✓
17.5					✓	✓	✓	✓	✓	✓
20.0						✓		✓	✓	✓
22.5								✓	✓	✓
25.0									✓	

Note: All dimensions in mm

Polyurethane Die Technical Guidelines

1. Select Die Pad required

Radius (mm) thk(mm)	10	15	17.5	20	25	30
0.4	Die 50 x 50			Die 80 x 30		
0.6						
0.8						
1.0						
1.2	Die 110 x 45			Die 110 x 45		
1.6						
2.3	Die 110 x 45			Die 110 x 45		
2.6						
3.2	Die 110 x 45			Die 110 x 45		

Larger die includes the application range of smaller die

2. Tonnage guidelines

Tonnage to bend 90° in Mild Steel (400N/mm²) using Die Holder # 60(4) with Die Pad 80x30 # 61(4)

Radius (mm) thk(mm)	10	15	17.5	20	25
0.4	13	16	18	21	26
0.6	15	18	21	24	29
0.8	17	21	23	27	33
1.0	19	23	27	30	36
1.2	22	25	29	34	39
1.6	26	30	34	40	46
2.3	34	39	43	50	58
2.6	37	43	47	55	63
3.2	48	54	60		

Tonnage required using Urethane Dies is 4-6 x more than standard steel dies. Please ensure that you are within the tonnage limits of both the tooling and machine when bending large radii or long lengths

3. Other considerations

- No marking
- Excellent radius shape
- One die for many radius applications
- High tonnage required
- Die pad is a consumable item
- Short flanges can be difficult

Polyurethane Holders

Width	Code	Length	Price	Tool #60 (1)
25mm	060011	835mm	£271	
	060012	415mm	£166	

Width	Code	Length	Price	Tool #60 (2)
30mm	060021	835mm	£271	
	060022	415mm	£166	

Width	Code	Length	Price	Tool #60 (3)
50mm	060031	835mm	£756	
	060032	415mm	£452	

Width	Code	Length	Price	Tool #60 (4)
80mm	060041	835mm	£756	
	060042	415mm	£452	

Width	Code	Length	Price	Tool #60 (5)
110mm	060051	835mm	£1,155	
	060052	415mm	£683	

Polyurethane Die Pads

Pad Size	Code	Length	Price	Tool #61 (1)
25 x 25	061121	835mm	£47	 <p>Polyurethane</p>
	061122	415mm	£22	

Pad Size	Code	Length	Price	Tool #61 (2)
25 x 30	061221	835mm	£50	 <p>Polyurethane</p>
	061222	415mm	£26	

Pad Size	Code	Length	Price	Tool #61 (3)
50 x 50	061321	835mm	£173	 <p>Polyurethane</p>
	061322	415mm	£93	

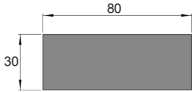
Pad Size	Code	Length	Price	Tool #61 (4)
30 x 80	061421	835mm	£165	 <p>Polyurethane</p>
	061422	415mm	£93	

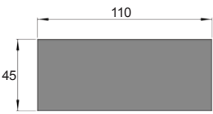
Pad Size	Code	Length	Price	Tool #61 (5)
45 x 110	061521	835mm	£336	 <p>Polyurethane</p>
	061522	415mm	£177	

Hemming

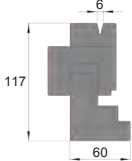
Angle	V-Size	Code	Length	Price	Tool #106310 – 65 t/m
30°	V6	1063101	835mm	£857	 <p>Was #10469</p>
		1063102	415mm	£517	

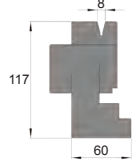
Angle	V-Size	Code	Length	Price	Tool #108310 – 65 t/m
30°	V8	1083101	835mm	£857	 <p>Was #10409</p>
		1083102	415mm	£517	

Angle	V-Size	Code	Length	Price	Tool #006310
30°	V6	0063101	835mm	£276	 <p>Was #80149</p>
		0063102	415mm	£167	



Angle	V-Size	Code	Length	Price	Tool #008310
30°	V8	0083101	835mm	£276	 <p>Was #80139</p>
		0083102	415mm	£167	

Note: For replacement bolts and springs see page 61

Hemming & Flattening

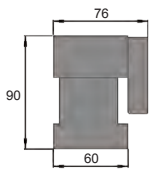
Angle	V-Size	Code	Length	Price	Tool #112220 – 100 t/m
26°	V12	1122201	835mm	£748	 Was #Z330
		1122202	415mm	£441	

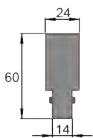
		Code	Length	Price	Tool #105
		105061	835mm	£683	
		105062	415mm	£452	

		Code	Length	Price	Tool #1600 STAGED – 100 t/m
Flattening		1600001	835mm	£349	 Was #OSF600
		1600002	415mm	£197	
		1600003	Sec	£526	
Tool Stop		1600011	835mm	£167	 Tool Stops
		1600012	415mm	£95	
		1600013	Sec	£243	

Note: Tool stop prevents thrust force and sideways movement of the tool. Use with Punch Holder #0282 or #0582 - see page 55. Tool is reversible and can be mounted on a punch or die holder.

Joggle Tools

Joggle	Code	Length	Price	Tool #Z3 STAGED – 100 t/m
3.0	1630061	835mm	£491	
	1630062	415mm	£276	
	1630063	Sec	£668	

Joggle	Code	Length	Price	Tool #Z4 STAGED – 100 t/m
4.0	1640081	835mm	£491	
	1640082	415mm	£276	
	1640083	Sec	£668	

Joggle	Code	Length	Price	Tool #Z5 STAGED – 100 t/m
5.0	1650101	835mm	£491	
	1650102	415mm	£276	
	1650103	Sec	£668	

Joggle	Code	Length	Price	Tool #Z6 STAGED – 100 t/m
6.0	1660101	835mm	£518	
	1660102	415mm	£290	
	1660103	Sec	£694	

Joggle	Code	Length	Price	Tool #Z8 STAGED – 100 t/m
8.0	1680101	835mm	£518	
	1680102	415mm	£290	
	1680103	Sec	£694	

Joggle Tools

Joggle	Code	Length	Price	Tool #Z10 STAGED – 100 t/m
10.0	1610101	835mm	£518	
	1610102	415mm	£290	
	1610103	Sec	£694	

Note: Use with #815 Die Holder & #582 (H=120) or #282 (H=90) Punch Holder below. Staged Joggle tools are reversible and can be mounted on a punch or die holder. Two of each code are required to make a punch and die set.

Punch Holder

Height	Code	Length	Price	Tool #0582 – 100 t/m
120mm	0582002	415mm	£511	<p>Was #OSPH582</p>

Height	Code	Length	Price	Tool #0282 - 100 t/m
90mm	0282002	415mm	£434	<p>Was #OSPH282</p>

Holders, Blocks & Rails

Height	Code	Length	Price	Tool #0815 – 100 t/m
51.5mm (use with 1V Dies)	0815001	840mm	£478	 <p>Was #815</p>
	0815002	420mm	£254	

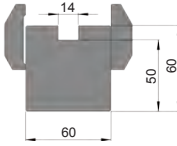
Height	Code	Length	Price	Tool #5330 – 100 t/m
50mm (use with 1V Dies or Heavy Duty)	5330001	1050mm	£713	 <p>Was #533</p>
	5330002	450mm	£363	

Height	Code	Length	Price	Tool #5340 – 100 t/m
90mm (use with 1V Dies)	5340001	1050mm	£552	
	5340002	450mm	£341	

Height	Code	Length	Price	Support for Tool #5340
90mm (use with #5340 above)	5340011	1050mm	£106	
	5340012	450mm	£66	

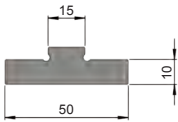
Height	Code	Length	Price	Tool #3000 Rail
10mm (use with 2V Reversible Dies)	3000001	835mm	£160	 <p>Was #300</p>
	3000002	415mm	£132	

Holders, Blocks & Rails

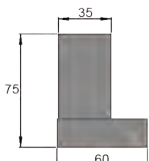
Height	Code	Length	Price	Tool #75H (2910)
75mm (use with 2V Dies)	2910001	835mm	£172	
	2910002	415mm	£87	

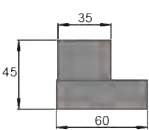
Height	Code	Length	Price	Tool #45H (2930)
45mm (use with 2V Dies)	2930001	835mm	£138	
	2930002	415mm	£75	

Height	Code	Length	Price	Tool #39H (2900)
39mm (use with 2V Dies)	2900001	835mm	£125	
	2900002	415mm	£64	

Height	Code	Length	Price	Tool #055
55mm	0550001	835mm	£314	
	0550002	415mm	£175	

Was #55

Height	Code	Length	Price	Adaptor for Polycarbonate Dies – 100 t/m
Adaptor (use with #5340 or #0815 holders)	3300011	834mm	£231	
	3300012	414mm	£128	

Rolla V

Model 1

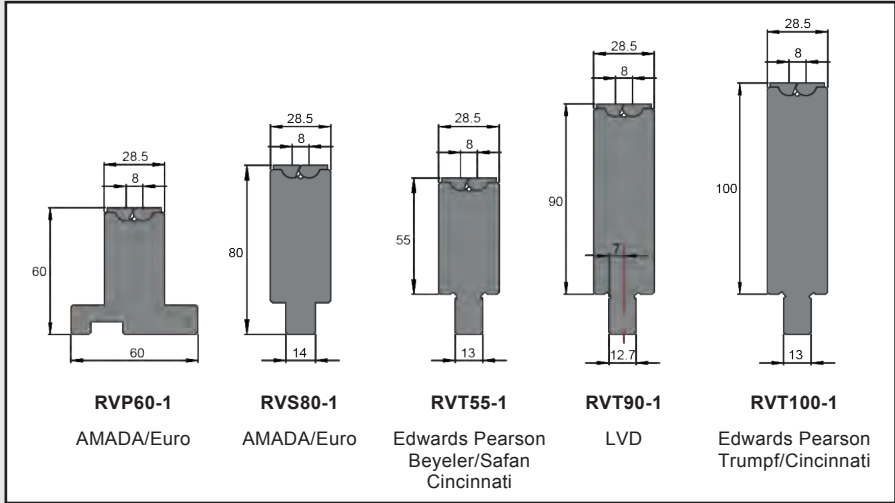

Model 2

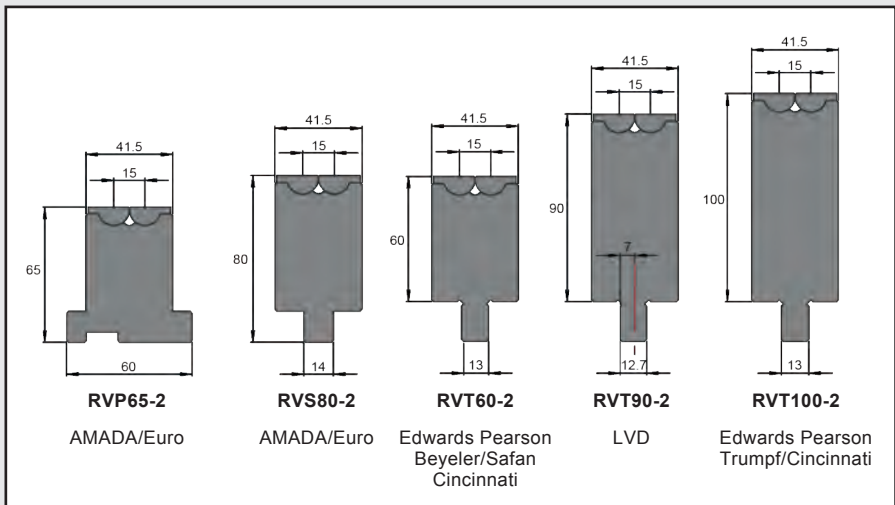

Rolla V

Model 3

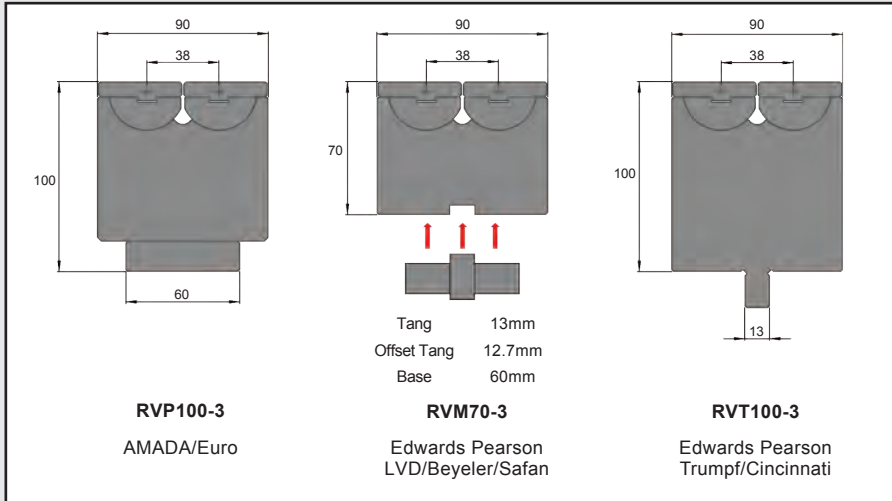

Lengths

Model	Length	Sec Length
Model 1	500mm	1x15, 1x20, 1x25, 1x30, 1x50, 1x100, 1x200 = 440mm
Model 2	500mm	1x20, 1x25, 1x30, 1x35, 1x40, 1x100, 1x200 = 450mm
Model 3	500mm	1x45, 1x50, 1x60, 1x100, 1x200 = 455mm

Model	Length	Length
Model 3 Adjustable & HD	200mm	500mm
Model 4 Adjustable	200mm	500mm

Please contact AMADA tooling for prices

Rolla V

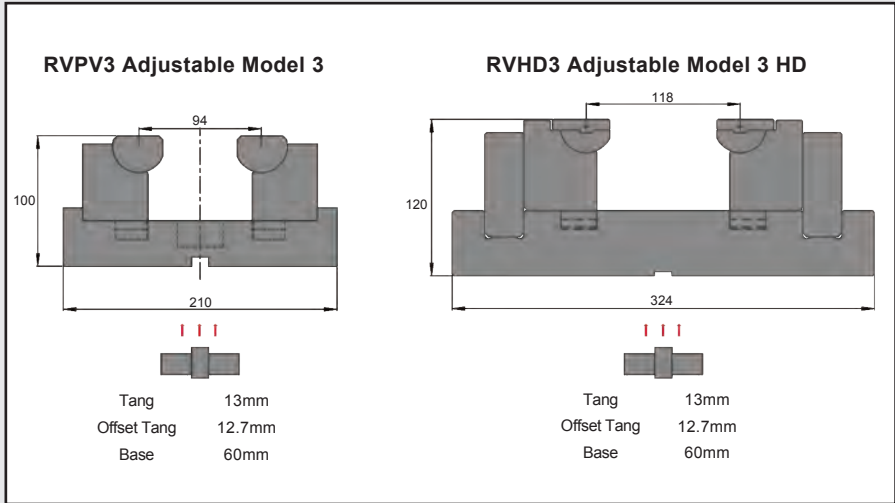

Model 3 Adjustable



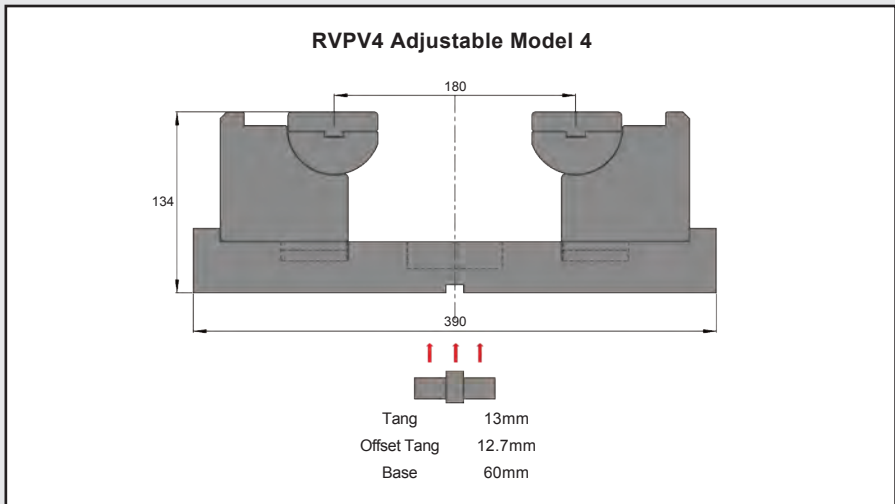

Model 4 Adjustable



Accessories

Code	Price	Magnetic Squaring Arm (LH)	Magnetic Squaring Arm (RH)
93000L (Left Hand)	£175		
93000R (Right Hand)	£175		

Code	Price	Side Gauge	Angle Gauge
930000 (Side Gauge)	£265		
935000 (Angle Gauge)	£103		

Code	Price	2V & 1V Die Accessories
800100	£0.70	Set bolt for 2V Die M8 x 25
800200	£1.51	Spring for 1V & 2V Die
800300	£1.51	Washer for 2V Die
800400	£0.70	Set bolt for 1V Die M8 x 30
800500	£3.24	Washer for 1V Die

Code	Price	Hemming Die Accessories
800600	£2.80	Stripper bolt STO 8 x 45
800690	£2.80	Stripper bolt STO 8 x 55
800800	£1.51	Spring
800900	£0.70	Fixing bolt M6 x 30

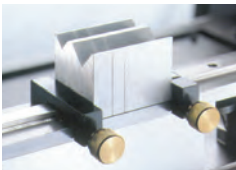
Code	Price	2V Die Stopper
936000	£63	

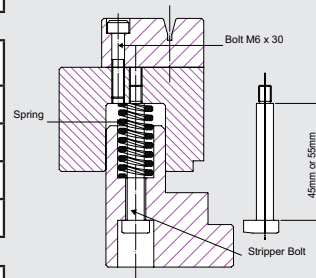

Urethane Sheet & Tape

Code	Price	Tool #42620	Tool #42619
426201 (0.3mm thick)	£16 Per metre	 <p>For use up to 1mm Mild Steel</p>	 <p>For use from 1mm - 2mm Mild Steel</p>
426191 (0.5mm thick)	£22 Per metre		

Code	Price	Tool #42618	Marking Protection Strip
426181 (1.0mm thick)	£32 Per metre	 <p>For use over 2mm Mild Steel</p>	
909910 (0.3mm thick)	£170 (10m)		

Tooling Cabinet

Tooling Cabinet:

Keep your tooling organised and free from workplace atmospheric dust.

Width	1040mm
Height	1240mm
Depth	1000mm

Code: 990000

Price: £1,740



Air Bending Tonnage Chart: Mild Steel

How to Read the Pressure Chart

If the material thickness and inner radius are known, the following information can be obtained from the chart below:

1. Tonnage required to bend material of 1 metre length
2. V-width to be used
3. Minimum flange length

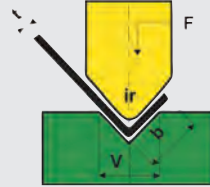

t mm	4	6	7	8	10	12	14	16	18	20	25	32	40	50	63	80	100	125	160	200	250	V																	
	2.8	4	5	5.5	7	8.5	10	11	13.5	14	17.5	22	28	35	45	55	71	89	113	140	175	b																	
	0.7	1	1.1	1.3	1.6	2	2.3	2.6	3	3.3	4	5	6.5	8	10	13	16	20	26	33	41	ir																	
0.5	4	3																																					
0.6	6	4	4	4																																			
0.8		7	7	5	4																																		
1		11	10	8	7	6																																	
1.2			14	12	10	8	7	6																															
1.4				15	13	11	10	9	8																														
1.6					17	15	13	11	10	9																													
2						22	19	17	15	13	11																												
2.3							25	23	19	17	15	12																											
2.6								28	25	22	18	14																											
3									34	30	24	19	15																										
3.2										34	27	22	17	14																									
3.5											33	26	20	16	13																								
4												43	34	27	21	17																							
4.5													44	34	27	21																							
5														52	42	33	26	21																					
6															60	48	38	30	24																				
7																	52	41	33	26																			
9																		67	54	43																			
10	t	Material thickness (tensile strength: 45 - 50kg/mm ²)																																					
12	F	Tonnage per 1 metre																																					
16	ir	Inside radius																																					
19	b	Minimum flange length																																					
22	V	V-width																																					
25																																							
30																							240																

Material Thickness and V-Width

The distance across the die opening is known as the V-width. The appropriate V-width should be selected in accordance with the thickness of material being bent. The table below shows the optimum relationship between the material thickness and V-width, although in practice this relationship is often determined by specific requirements, including flange lengths (b), the components inner bend radius (ir) and the tonnage capacity of the machine and tooling.

Relationship of Material Thickness (t) and V-Width

Material Thickness (t) mm	0.5 - 2.5	3.0 - 8.0	9.0 - 10.0	12.0 or more
V-Width	6 x t	8 x t	10 x t	12 x t

Air Bending Tonnage Chart: Stainless Steel

How to Read the Pressure Chart

If the material thickness and inner radius are known, the following information can be obtained from the chart below:

1. Tonnage required to bend material of 1 metre length
2. V-width to be used
3. Minimum flange length

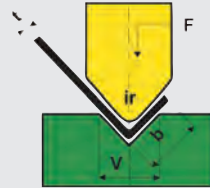

t mm	4	6	7	8	10	12	14	16	18	20	25	32	40	50	63	80	100	125	160	200	250	V	
	2.8	4	5	5.5	7	8.5	10	11	13.5	14	17.5	22	28	35	45	55	71	89	113	140	175	b	
	0.7	1	1.1	1.3	1.6	2	2.3	2.6	3	3.3	4	5	6.5	8	10	13	16	20	26	33	41	ir	
0.5	6	5																					
0.6	9	6	6	6																			
0.7	12	8	8	6	6																		
0.8		11	11	8	7																		
0.9		13	12	10	8	7																	
1		17	15	12	11	8																	
1.2			21	18	15	12	11	9															
1.5						20	17	15	13	12													
2						33	29	26	23	20	17												
2.5								39	35	30	25	19											
3									51	45	36	29	23										
4											65	51	41	32	26								
5												78	63	50	39	32							
6													90	72	57	45	36						
8	t	Material thickness (tensile strength: 52 - 60kg/mm ²)																					
10	F	Tonnage per 1 metre																					
12	ir	Inside radius																					
15	b	Minimum flange length																					
20	V	V-width																					
25																							
30																							360

Press Brake Tooling

Material Thickness and V-Width

The distance across the die opening is known as the V-width. The appropriate V-width should be selected in accordance with the thickness of material being bent. The table below shows the optimum relationship between the material thickness and V-width, although in practice this relationship is often determined by specific requirements, including flange lengths (b), the components inner bend radius (ir) and the tonnage capacity of the machine and tooling.

Relationship of Material Thickness (t) and V-Width

Material Thickness (t) mm	0.5 - 2.5	3.0 - 8.0	9.0 - 10.0	12.0 or more
V-Width	6 x t	8 x t	10 x t	12 x t

Further Information



For further information about AMADA's products and services, please contact:

Machines:

Tel: 01562 749 737
E-mail: info@amada.co.uk
www.amada.co.uk/product

Service/Software:

Tel: 01562 749 555
E-mail: shl@amada.co.uk
E-mail: software@amada.co.uk
www.amada.co.uk/service

Tooling:

Tel: 01562 749 761
E-mail: tooling.info@amada.co.uk
www.amada.co.uk/service/tooling

Parts & Consumables:

Tel: 01562 749 524
E-mail: parts@amada.co.uk
www.amada.co.uk/service/parts

01562 749 500 info@amada.co.uk www.amada.co.uk