

Report No. 78-113
Contract No. NAS8-33244

STANDALONE ENGINE SIMULATOR (SAES)
ENGINE DYNAMICS SIMULATOR (EDS)
XEROX SIGMA 5
INTERFACE HARDWARE MANUAL

(NASA-CR-161301) STANDALONE ENGINE SIMULATOR (SAES), ENGINE DYNAMICS SIMULATOR (EDS) XEROX SIGMA 5. INTERFACE HARDWARE MANUAL (M&S Computing, Inc., Huntsville, Ala.) : 111 p. HC A06/MF A01 N79-32213 Unclas 38176 CSCL 21E G3/07

July 17, 1979



Prepared for:

George C. Marshall Space Flight Center
National Aeronautics and Space Administration
Marshall Space Flight Center, Alabama 35812

PREFACE

Presented in this document are hardware descriptions of the Engine Dynamics Simulator (EDS) - Engine Sensor Simulator (ESS) and EDS - Xerox Sigma 560 (Sigma) interfaces. Development of these interfaces was performed by M&S Computing, Inc., under Contract No. NAS8-33244 for the Engineering Management Office of the Shuttle Projects Office of George C. Marshall Space Flight Center (MSFC). The NASA COR for this contract is Mr. B. J. Funderburk, SA23.

Prepared by:

Philip M. Kirshtein
Schelly Black
Ray Pearson

Approved by:



H. A. Helton

TABLE OF CONTENTS

<u>Section</u>	<u>Page</u>
1. SCOPE OF DOCUMENT	1
2. APPLICABLE DOCUMENTS	3
3. EDS-ESS INTERFACE	5
3.1 General Information	5
3.2 Data Paths Provided for Different Modes of Operation	5
3.2.1 Block Diagram Information	5
3.2.2 Self-Test Data Paths	10
3.2.3 Reading Interface Status	10
3.2.4 Loading the Address Register	10
3.2.5 Transferring D/A Data to the ESS	10
3.2.6 Transferring A/D Data from the ESS	10
3.3 Control, Signals, and Logic	16
3.3.1 Control Signals	16
3.3.2 D/A Control Logic	16
3.3.3 A/D Control Logic	16
4. EDS SIGMA 506 INTERFACE	19
4.1 General Information	19
4.2 Data Paths Provided for Different Modes of Operation	19
4.2.1 Block Diagram Information	19
4.2.2 Self-Test Data Path	19
4.2.3 Transferring Data to the Sigma 560	24
4.2.4 Transferring Data from the Sigma	24
APPENDIX A	A-1
APPENDIX B	B-1
APPENDIX C	C-1

LIST OF FIGURES

<u>Section</u>	<u>Title</u>	<u>Page</u>
3.1-1	SAES System Configuration Block Diagram	6
3.1-2	SAES ESS/EDS Interface - Interface Interconnect	7
3.1-3	SAES ESS/EDS Interface - UDIF/ESS Interface Connector Pin Functions	8
3.2.1-1	SAES ESS/EDS Interface Block Diagram	9
3.2.2-1	SAES ESS/EDS Interface Block Diagram Self-Test Data Paths	11
3.2.3-1	SAES ESS/EDS Interface Block Diagram Read Status Data Path	12
3.2.4-1	SAES ESS/EDS Interface Block Diagram Load Address Register Data Path	13
3.2.5-1	SAES ESS/EDS Interface Block Diagram Write D/A Data Path	14
3.2.6-1	SAES ESS/EDS Interface Block Diagram Read A/D Data Path	15
3.3.2-1	SAES ESS/EDS Interface D/A Control Timing Diagram	17
3.3.3-1	SAES ESS/EDS Interface A/D Control Timing Diagram	18
4.1-1	SAES/MMES Interface - EDS/7902 Interface Interconnect	20
4.1.2	SAES/MMES Interface - UDIF/7902 Interface Connector Pin Functions	21
4.2.1-1	SAES/MMES Interface - Interface Block Diagram	22
4.2.2-1	SAES/MMES Interface - Interface Self-Test Data Path	23
4.2.3-1	SAES/MMES Interface Block Diagram - SAES to MMES Transfer Data Path	24
4.2.3-2	SAES/MMES Interface - SAES to MMES Transfer Timing Diagram	25
4.2.4-1	SAES/MMES Interface Block Diagram MMES to SAES Transfer Data Path	26
4.2.4-2	SAES/MMES Interface - SAES to MMES Transfer Timing Diagram	27

LIST OF ACRONYMS

DEC	Digital Equipment Corporation
EDS	Engine Dynamics Simulator
ESS	Engine Sensor Simulator
HEF	High External Function
HEFA	High External Function Acknowledge
HOA	High Output Acknowledged
HODR	High Output Data Ready
MSFC	Marshall Space Flight Center
NASA	National Aeronautics and Space Administration
SAES	Standalone Engine Simulator
UDIF	Unibus DMA Interface

1. SCOPE OF DOCUMENT

This document is intended as a description of the ESS-EDS and EDS-Sigma interfaces within the Standalone Engine Simulator (SAES).

The operation of these interfaces, including the definition and use of special function signals and data flow paths within them during data transfers, is presented along with detailed schematics and circuit layouts of the described equipment.

(BLANK)

2. APPLICABLE DOCUMENTS

The following is a list of documents which describe hardware connected to these interfaces and software used to communicate through them.

- Standalone Engine Simulator, Engine Sensor Simulator Hardware Manual, Report No. 78-112, dated April 16, 1979.
- Model 7902 Extended Device Subcontroller Technical Specifications, XDS 98 03 93A.
- Standalone Engine Simulator Engine Dynamic Simulator Simulation Program Detailed Design Specification/Software User Manual, Report No. 78-118, dated April 16, 1979.
- Unibus DMA Interface Manual, Report No. 79-014, dated April 25, 1979.

PRECEDING PAGE BLANK NOT FILMED

(BLANK)

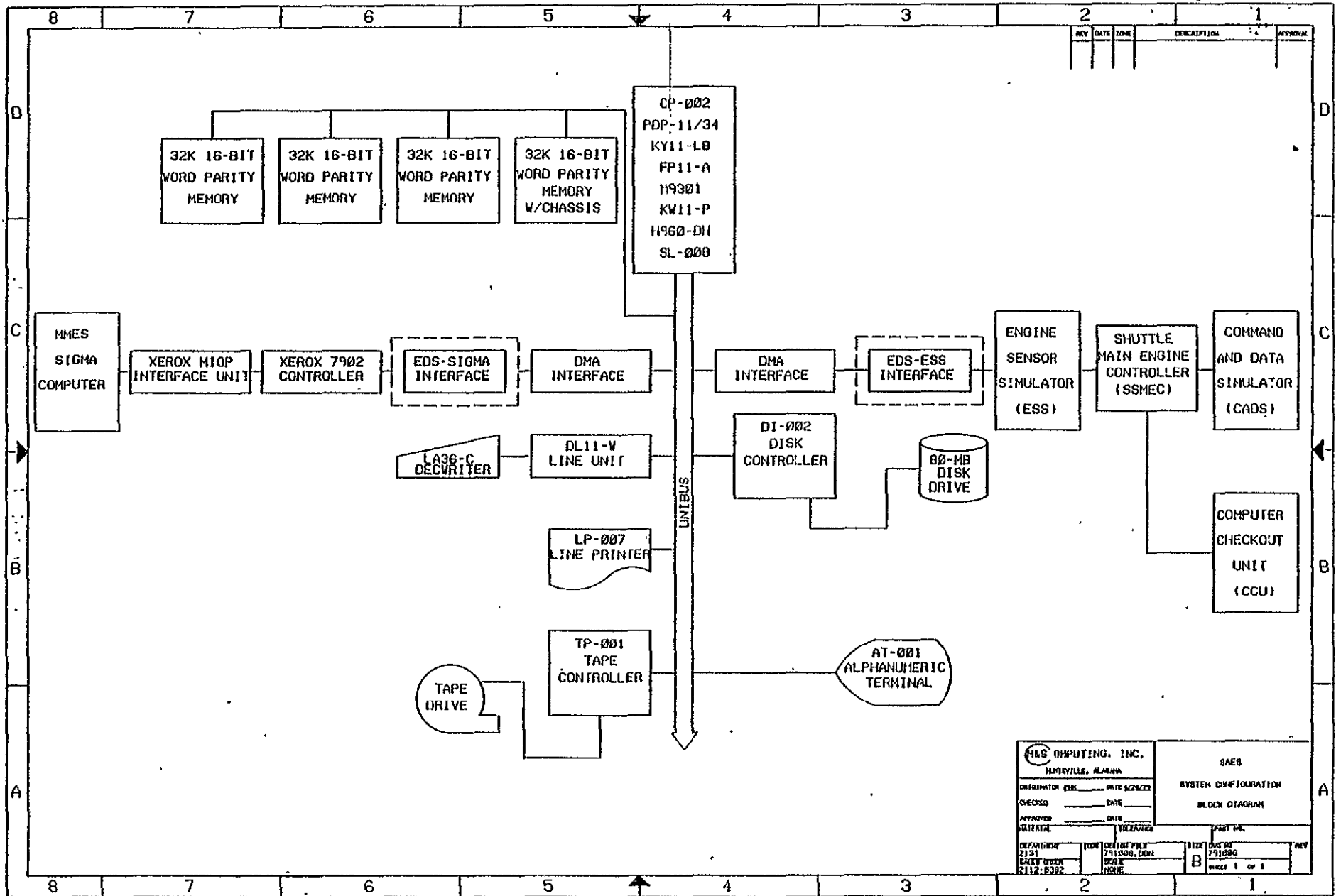

MILS COMPUTING, INC. TUSSEVILLE, ALABAMA		SAEB	
DESIGNATOR: 2131		SYSTEM CONFIGURATION	
CHECKED: 2112-8392		BLOCK DIAGRAM	
APPROVED: _____		DATE: _____	
REVISED: _____		DATE: _____	
DEPARTMENT: 2131	DESIGN FILE: 791508, DDN	BOX: B	DWG NO: 791508
DATE: 2112-8392	SCALE: NONE	SHEET 1 OF 1	

FIG. 3.1:1

- 9 - PRECEDING PAGE BLANK NOT FILMED

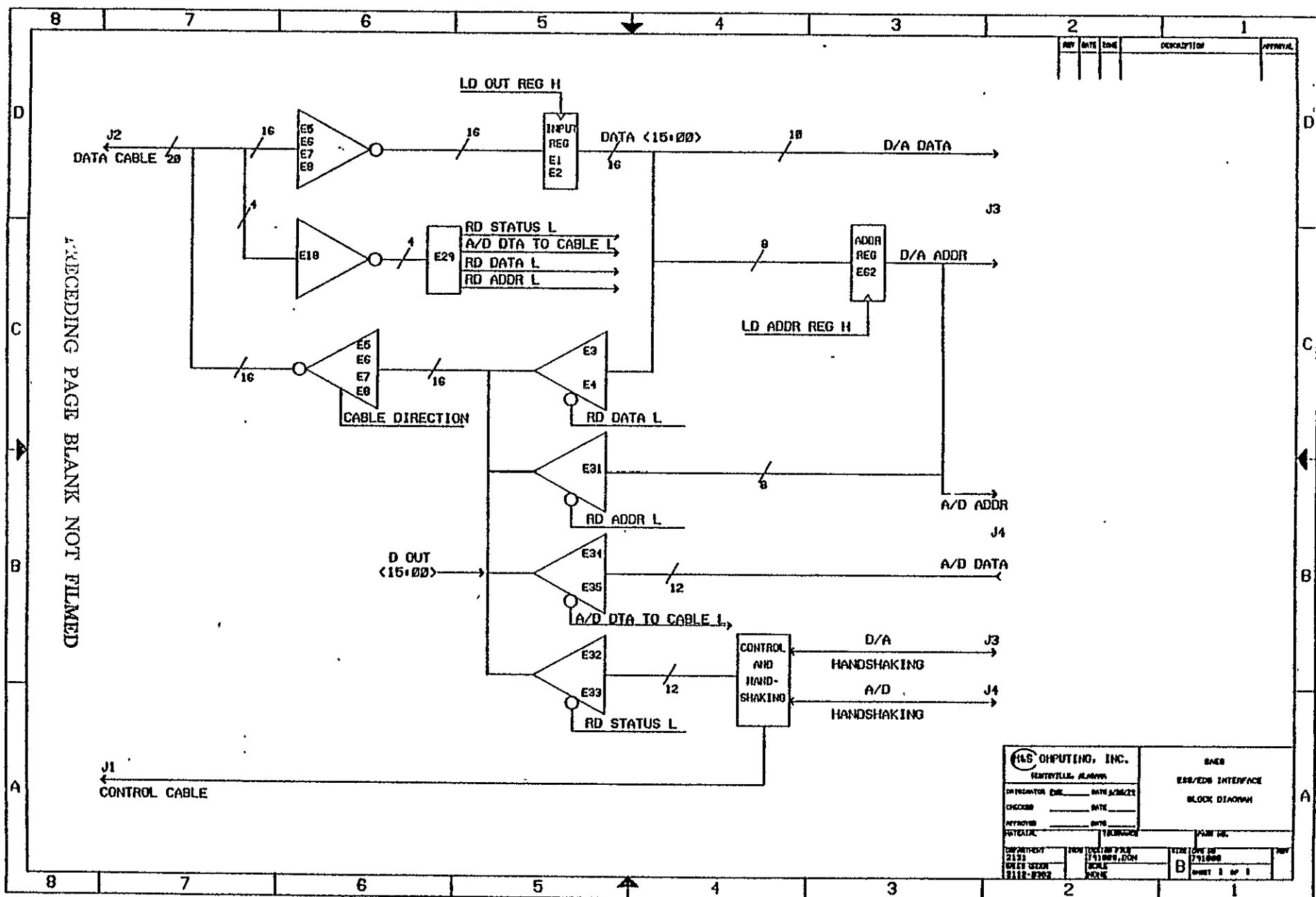

IBM COMPUTING, INC. BENTONVILLE, ALABAMA		SALES	
DIRECTOR: _____ DATE: 5/26/71		ESS/EDS INTERFACE	
CHECKED: _____ DATE: _____		BLOCK DIAGRAM	
APPROVED: _____ DATE: _____		PARTIAL: _____	
DEPARTMENT: 2132		DATE: 7/18/71	SCALE: 1/16" = 1"
PROJECT: 2132-2000		SCALE: 1/16" = 1"	REV: B
1112-2000		PAGE 1 OF 1	

FIG. 9.2.1-1

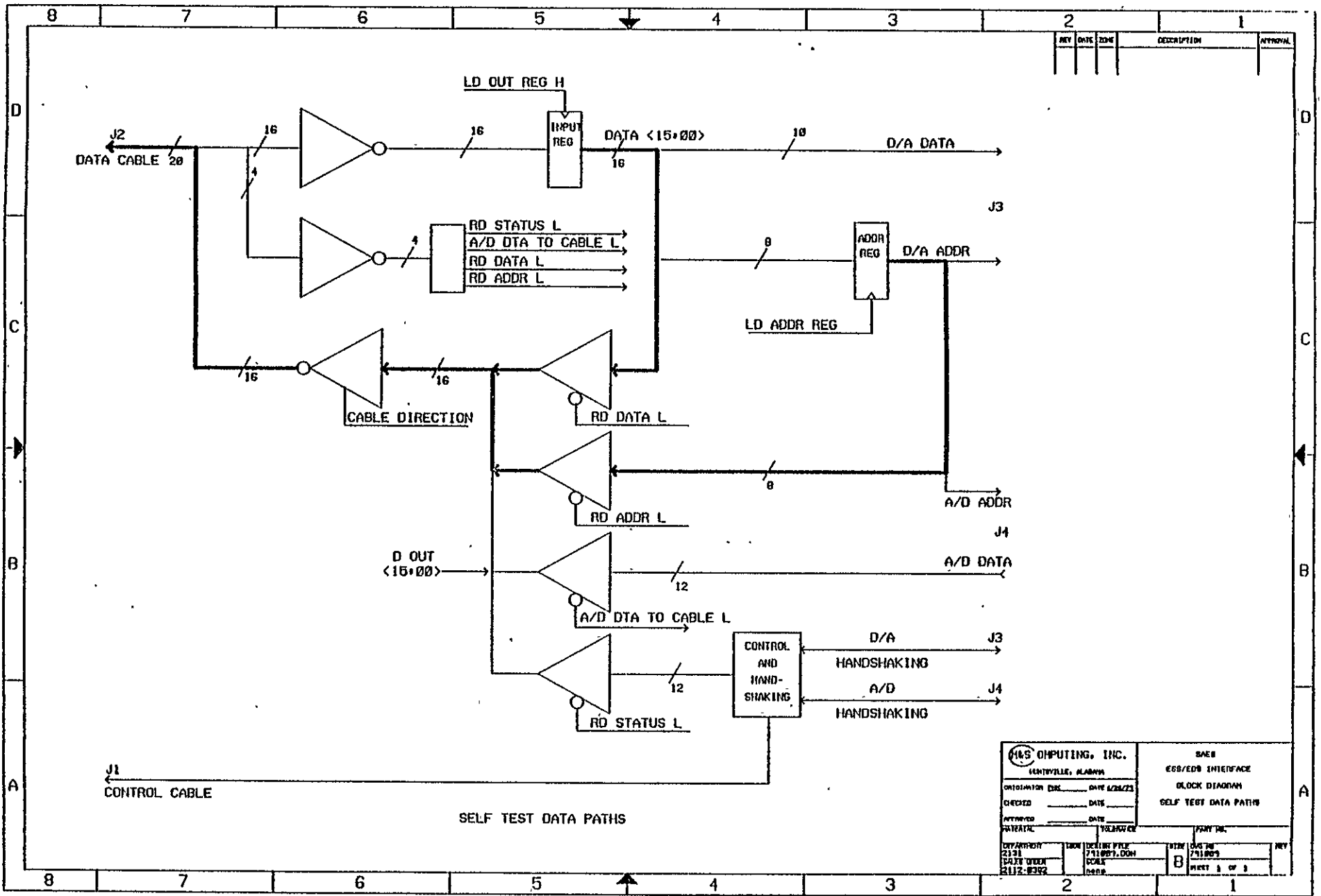

QIS COMPUTING, INC. CENTVILLE, ALABAMA		SAES EGS/EDS INTERFACE	
ORIGINATOR: DRG	DATE: 6/26/73	BLOCK DIAGRAM	
CHECKED:	DATE:	SELF TEST DATA PATHS	
APPROVED:	DATE:		
BY: [Signature]	FOR: [Signature]	FORM NO.	
DEPARTMENT: 2121	ENGINE FILE: 711807.D08	REV: B	DATE: 7/1/80
DATE ORDER: 2112-8392	QUANTITY:	PAGE 2 OF 3	

- 11 -

FIG. 3.2.2-1

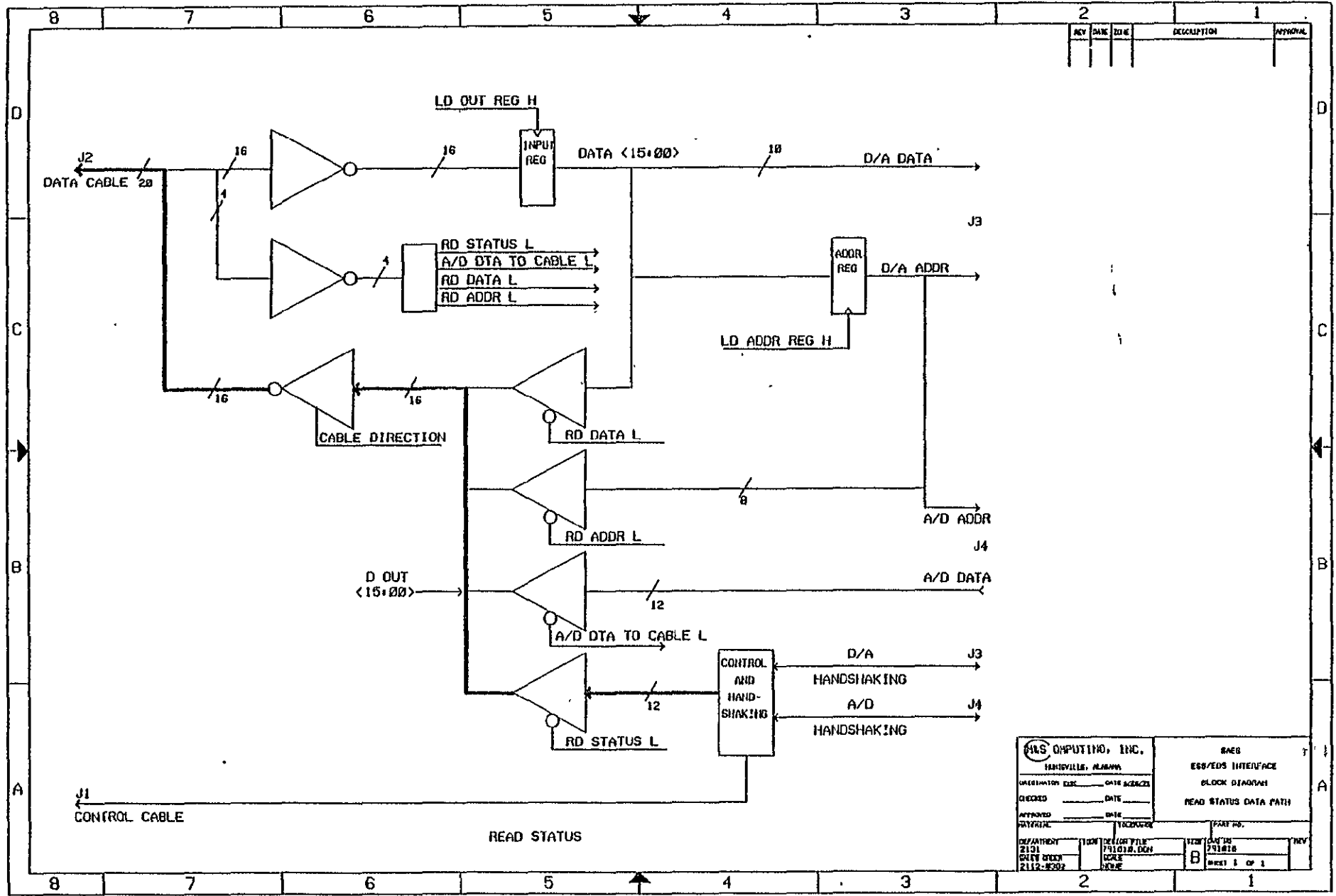

ALS COMPUTING, INC. FENTONVILLE, ALABAMA		SAES ESS/EDS INTERFACE BLOCK DIAGRAM READ STATUS DATA PATH	
DESIGNATION: _____	DATE: _____	DESIGNER: _____	DATE: _____
CHECKED: _____	DATE: _____	APPROVED: _____	DATE: _____
DEPARTMENT: 2131 DATE DRAWN: 2/11/72		DRAWN BY: DCM CHECKED BY: HVE	
TITLE: 2112-#302		PART NO.: _____ SHEET: B OF: 1	

-12-

FIG. 3.2.3-1

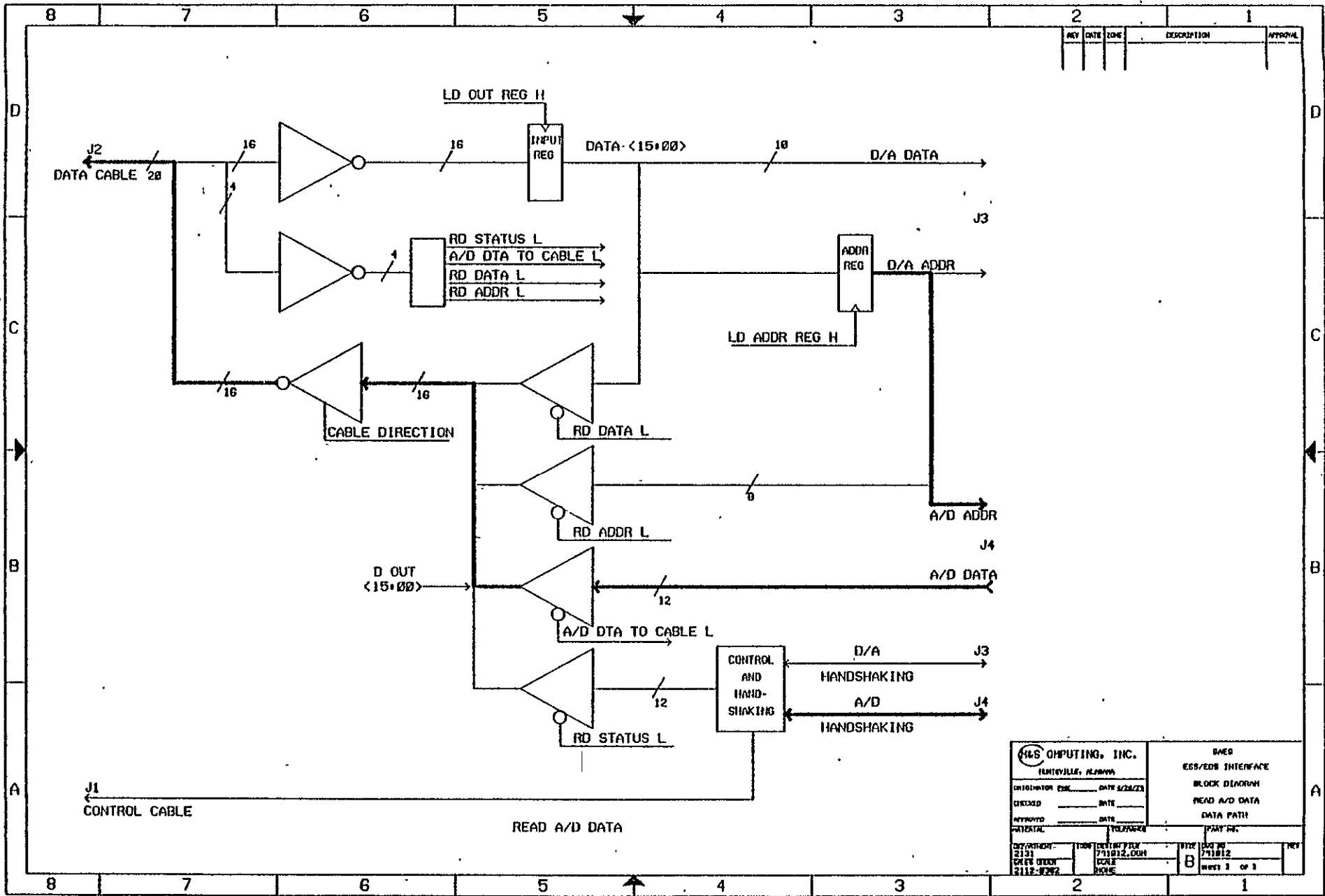

REV	DATE	ZONE	DESCRIPTION	APPROVAL

TELECOMPUTING, INC. (MONTREAL, ALABAMA)		BAEF ESS/EDS INTERFACE BLOCK DIAGRAM	
INDICATOR: _____ CIRCUIT: _____ REVISION: _____ MATERIAL: _____	DATE: _____ DATE: _____ DATE: _____	DATE: _____ DATE: _____ DATE: _____	DATE: _____ DATE: _____ DATE: _____
DRAWING: 2112 DATE: 08/08 FILE: 2112-8282	TITLE: 751812.000 SCALE: NONE	SIZE: B SHEET: 1 of 1	DESIGNED BY: _____ CHECKED BY: _____ DATE: _____

FIG. 3.2.0-1

3.2.2-1). Both loops require that the input register, E1 and E2, be loaded from the data bus. The first loop provides for reading the contents of the input register through tristate buffers E3 and E4 (RD DATA L). The second loop requires that the address register E62 be loaded with data contained in the input register. (Note, this is an 8-bit register). In this case, the self-test loop is completed through E31, (RD ADDR L).

In either self-test loop, the data read back from a register should match, bit for bit with the data loaded into that register.

3.2.3 Reading Interface Status

The status of the interface and the ESS may be read by the UDIF through tristate buffers E32 and E33 (RD STATUS L). See Figure 3.2.3-1. All interface/ESS handshaking signals may be read through this path.

3.2.4 Loading the Address Register

The ESS address register may be loaded with data on J2 by first loading the input register with the desired data (LD OUT REG H) and then loading the address register with that data from the input register. See Figure 3.2.4-1. This process is done for both ESS analog-to-digital (A/D) and digital-to-analog (D/A) addresses.

3.2.5 Transferring D/A Data to the ESS

To transfer data to the ESS, the device address in the ESS for which the data is intended must first be loaded into the interface address register (see Figure 3.2.5-1). After the address register has been loaded, the interface input register is loaded with the new data for the ESS. Handshaking then takes place between the interface and the ESS. High Output Data Ready (HODR) is activated, and remains high until the ESS responds with High Output Acknowledged (HOA).

3.2.6 Transferring A/D Data from the ESS

To transfer A/D data from the ESS, the device address in the ESS from which data is required must first be loaded into the interface address register (see Figure 3.2.6-1). After the address register has been loaded, handshaking takes place between the interface and the ESS. High External Function HEF) goes high and remains high until High External Function Acknowledge (HEFA) is received from the ESS.

3.3 Control, Signals, and Logic

3.3.1 Control Signals

User-defined signals from the UDIF are used in the interface for three functions:

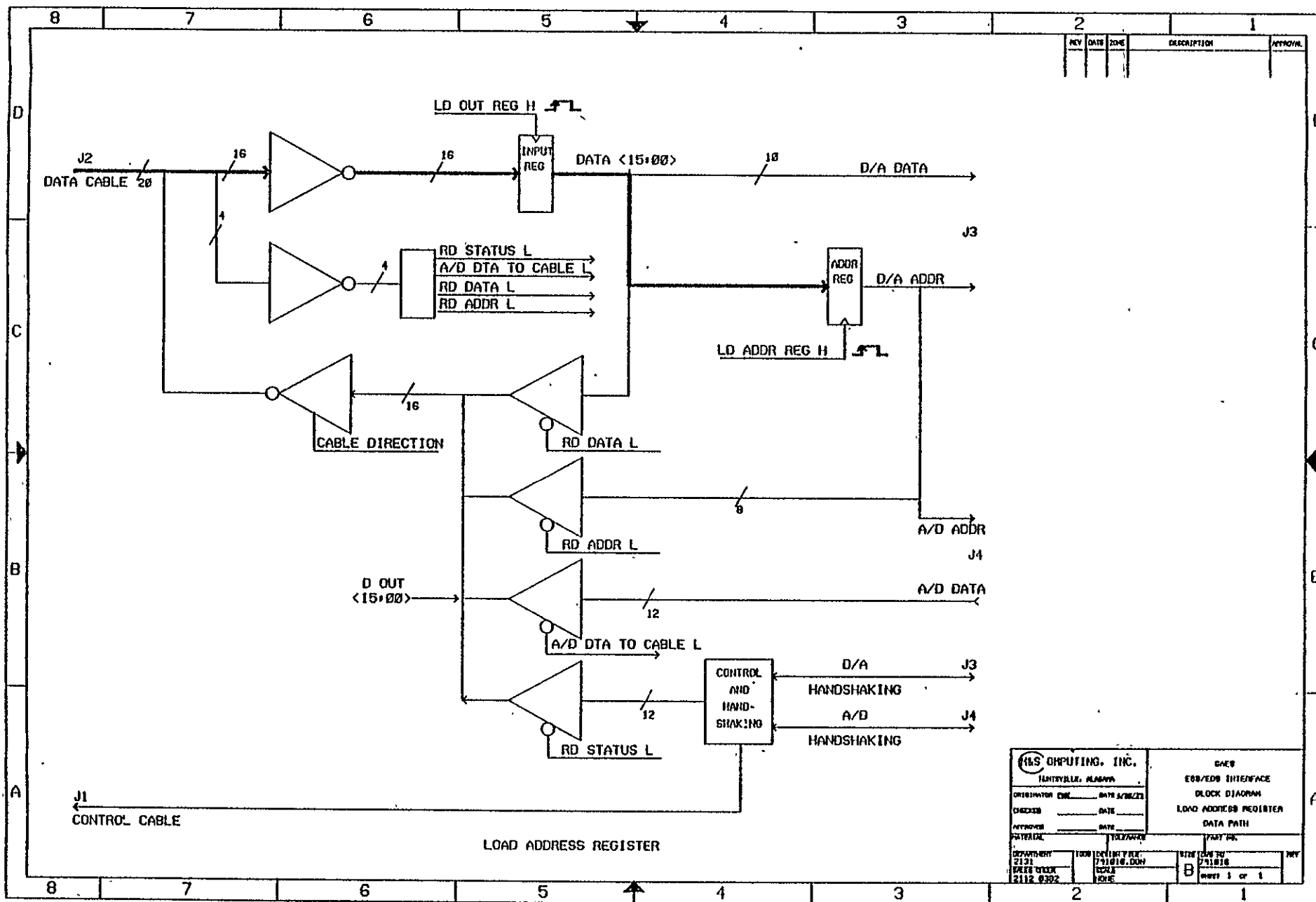

IBS COMPUTING, INC. HUNTSVILLE, ALABAMA		DATE ESB/EDS INTERFACE BLOCK DIAGRAM LOAD ADDRESS REGISTER DATA PATH	
DESIGNER: EML CHECKED: _____ APPROVED: _____ DATE: _____	DATE: _____ DATE: _____ DATE: _____	DATE: _____ DATE: _____ DATE: _____	DATE: _____ DATE: _____ DATE: _____
DEPARTMENT: 2131 FILE: 2112 0302	1000 DATE: 2/18/80 FILE: 2112 0302	1000 DATE: 2/18/80 FILE: 2112 0302	1000 DATE: 2/18/80 FILE: 2112 0302

FIG. 3.2.4-1

4. EDS SIGMA 560 INTERFACE

4.1 General Information

The EDS Sigma 560 interface (referred to as the interface in Section 4.) is composed of two boards: one DEC hex high wirewrap card (W9500), card 1, located in the EDS memory cabinet, and one Xerox wirewrap card, card 2, located remotely in a model 7902 Extended Device Controller. Power for card 1 is supplied from the memory backplane in which it is installed. Card 2 contains a +5 volt regulator and obtains +8 volts from the 7902 in which it is installed.

Communication with the interface from the EDS end takes place through two ribbon cables connected to an M&S Computing MI-018 PDP-11 Unibus DMA Interface also located in the EDS memory cabinet. For UDIF replacement information, see Appendix C. Communication between interface card 1 and card 2 takes place through a single 50-conductor ribbon cable. Interface card 2 communicates with the Sigma 560 through the model 7902 subcontroller (the model 7902 will be considered as part of the Sigma 560 hereafter). Data paths are wirewrapped on the 7902 backplane.

Interface cards 1 and 2 are completely isolated from each other by optical means. Figure 3.1-1 shows how this interface fits into the P6 SAES configuration. Figure 4.1-1 shows the interconnect between this interface and adjacent subsystems. Figure 4.1-2 shows the connector pin function for this interface.

4.2 Data Paths Provided for Different Modes of Operation

4.2.1 Block Diagram Information

Figure 4.2.1-1 is an operational block diagram of the interface. All blocks in this diagram except for the control and handshaking blocks contain designators referring to integrated circuits comprising that block. Bus and signal names used on the block diagram are the same as those used on the schematic, Appendix B.

The number of lines in each bus on the block diagram is designated by a slash mark adjacent to which is a number specifying the number of lines in that bus.

4.2.2 Self-Test Data Path

Figure 4.2.2-1 shows the built-in interface self-test path. Data which has been latched in input register E7 of card 1 is wrapped back around to card 1 as D OUT by E10 and E11 on card 2. This wrapped around data should match bit for bit with the data that was latched in the input register of card 1. EN CSL H is not asserted for this function.

- 1 FCN 1 Select D/A (active low).
2. FCN 2 Enable parity error (active high).
3. FCN 3 Reset (active high).

NOTE: The parity error bit is connected; however, the parity error circuitry in the interface is not connected back to the UDIF.

3.3.2 D/A Control Logic

Figure 3.3.2-1 shows a timing diagram of signals used in a D/A transfer. The transfer shown is for a single address and data word. If more than one word of data is to be sent to the ESS, the sequence followed by LD DEST REG L, LD ADDR H, TSYNC H, HOA, and HODR will be repeated, transferring one word, address and data, for every cycle as shown until WD CNTR OVF L is asserted by the UDIF. The timing diagram begins in an interface reset state.

3.3.3 A/D Control Logic

Figure 3.3.3-1 shows a timing diagram of signals used in an A/D transfer. The sequence shown is for two words of data, from consecutive addresses in the ESS, being transferred to the EDS. The starting ESS address is loaded when HEF is asserted. After conversion in the ESS (time-dependent on address), HIDR is received, initiating a cycle which will be repeated until WD CNTR OVF H is received from the UDIF ending the block transfer.

The ESS A/D controller reset (HLWF) is asserted by the interface as the inverse of SEL D/A L. The timing diagram begins in an interface reset state.

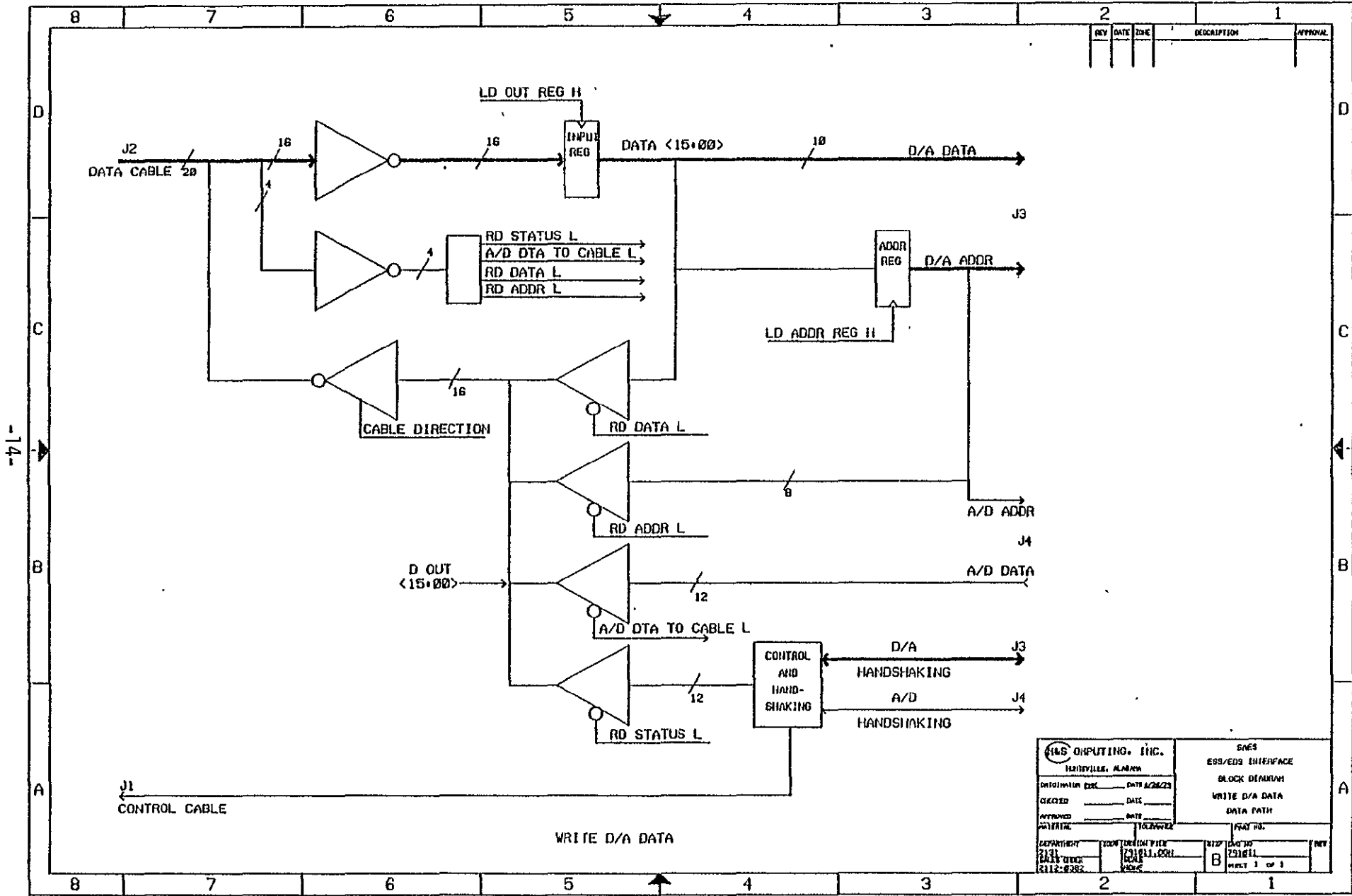

SIG COMPUTING, INC. MADISONVILLE, ALABAMA		ESS/EDS INTERFACE	
ORIGINATOR DESK _____	DATE ACB/23 _____	BLOCK DESIGN	
CHECKED _____	DATE _____	WRITE D/A DATA	
APPROVED _____	DATE _____	DATA PATH	
DATE _____	TOLERANCE _____	PAGE NO. _____	
DEPARTMENT _____	CONTROL ROOM _____	REV _____	REV _____
DATE _____	SCALE _____	B	731811
5112-8382	8382	PART 1 OF 1	

FIG. 3.2.6-1

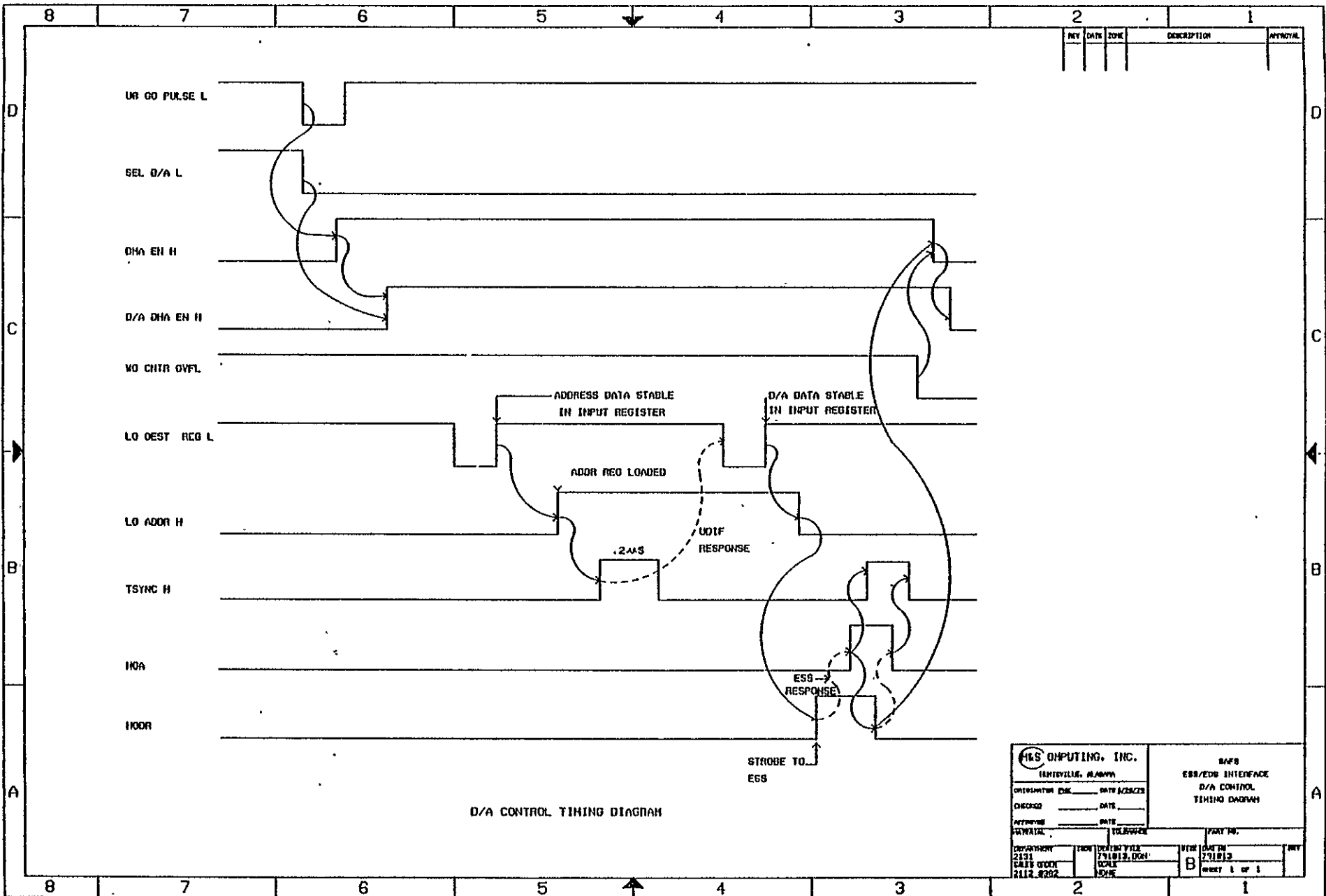

D/A CONTROL TIMING DIAGRAM

FILES OUTPUTING, INC. FENTLEVILLE, ALABAMA		SAFS ESS/EDS INTERFACE D/A CONTROL TIMING DIAGRAM	
DESIGNED BY	DATE	DATE	DATE
CHECKED	DATE	DATE	DATE
APPROVED	DATE	DATE	DATE
REVISED	DATE	DATE	DATE
DEPARTMENT	TRON	DESIGN FILE	FILE NO.
2131	791813.DON	B	731813
SALES CODE	SCALE	REV	REV
2112.8382	1/8"	B	1

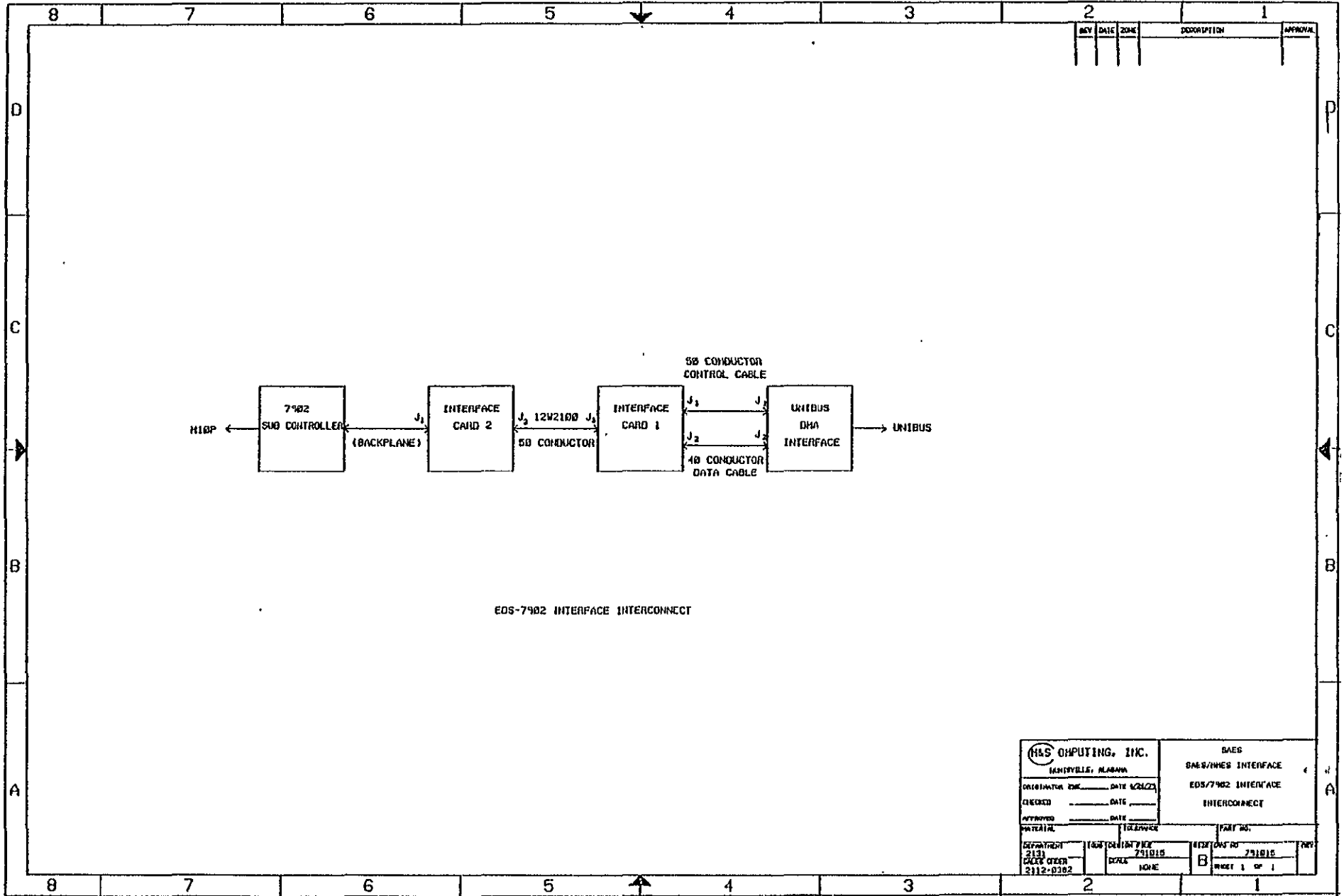

EOS-7902 INTERFACE INTERCONNECT

		BAES SAES/HNES INTERFACE	
MOBILE, ALABAMA		EOS-7902 INTERFACE INTERCONNECT	
ORIGINATOR DSK _____	DATE 4/21/72	APPROVED _____	
CHECKED _____	DATE _____	MATERIAL _____	
DEPARTMENT 213	TECH CENTER 251015	DRAWING NO. B	SHEET 1 OF 1
CALL ORDER 2112-0302	DATA NONE	PART NO.	

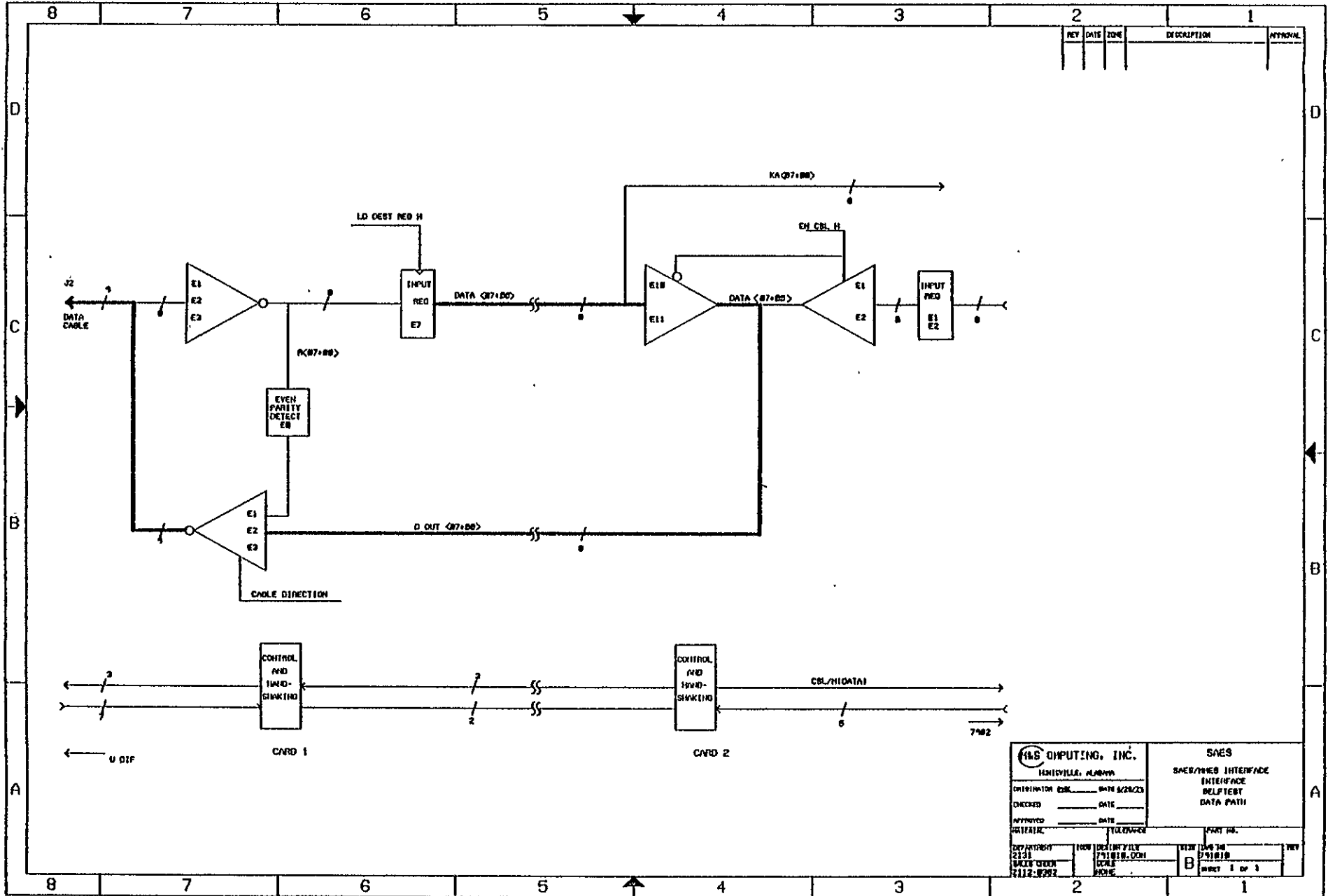

FLS COMPUTING, INC. HENRIEVILLE, ALABAMA		SAES SAES/ONES INTERFACE INTERFACE DELTAY DATA PATH	
ORIGINATOR	DATE	DATE	DATE
CHECKED	DATE	DATE	DATE
APPROVED	DATE	DATE	DATE
DESIGNED	DATE	DATE	DATE
DEPARTMENT	HOW IDENTIFIED	HOW IDENTIFIED	HOW IDENTIFIED
2131	7/18/68.DCH	7/31/68	7/31/68
BACKSHEET	SCALE	SCALE	SCALE
2112-8992	NONE	NONE	NONE
sheet 1 of 1		sheet 1 of 1	

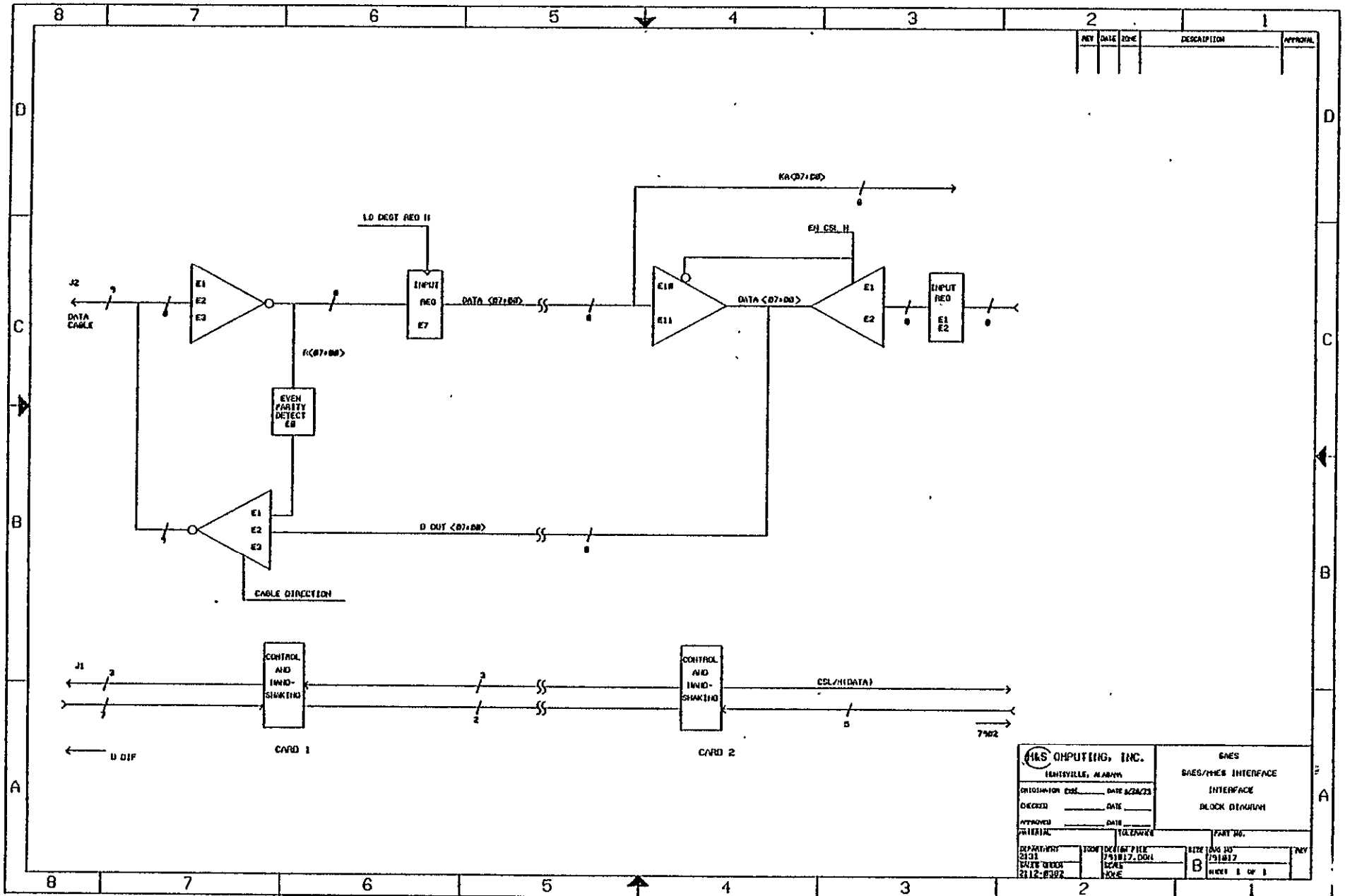

GMS COMPUTING, INC. MEMPHISVILLE, ALABAMA		GMS GMS/IBM INTERFACE	
ORIGINATOR DES. _____	DATE ACCTD _____	INTERFACE	
CHECKED _____	DATE _____	BLOCK DIAGRAM	
APPROVED _____	DATE _____		
PARTIAL _____	TOLERANCE _____	PART NO. _____	
DEPARTMENT 2131	WORK CENTER 751817-DD1	SIZE (AS SH)	REV
SCALE 1:12-6392	SCALE NONE	B	751817
		SHEET 1 OF 1	

FIG. 4.2.1-1

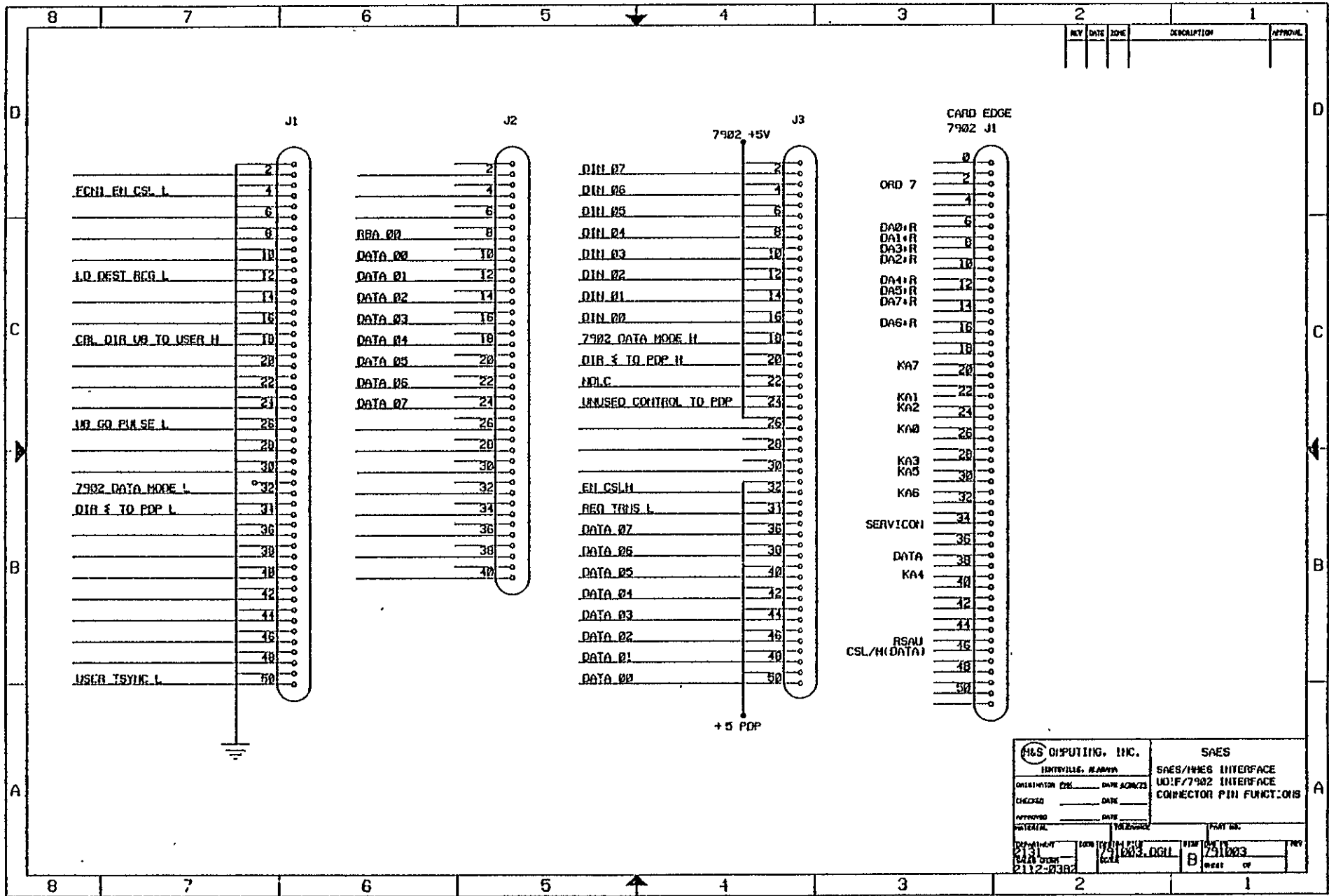

H&S COMPUTING, INC. BENTONVILLE, ARKANSAS		SAES SAES/H&S INTERFACE UOIF/7902 INTERFACE CORRECTOR PIN FUNCTIONS	
DESIGNER	DATE	ZONE	APPROVAL
2112-R382	7/25/83	083-DGL	7/31/83
2112-R382	SCALE	8	WEST OF

FIG 4.1-2

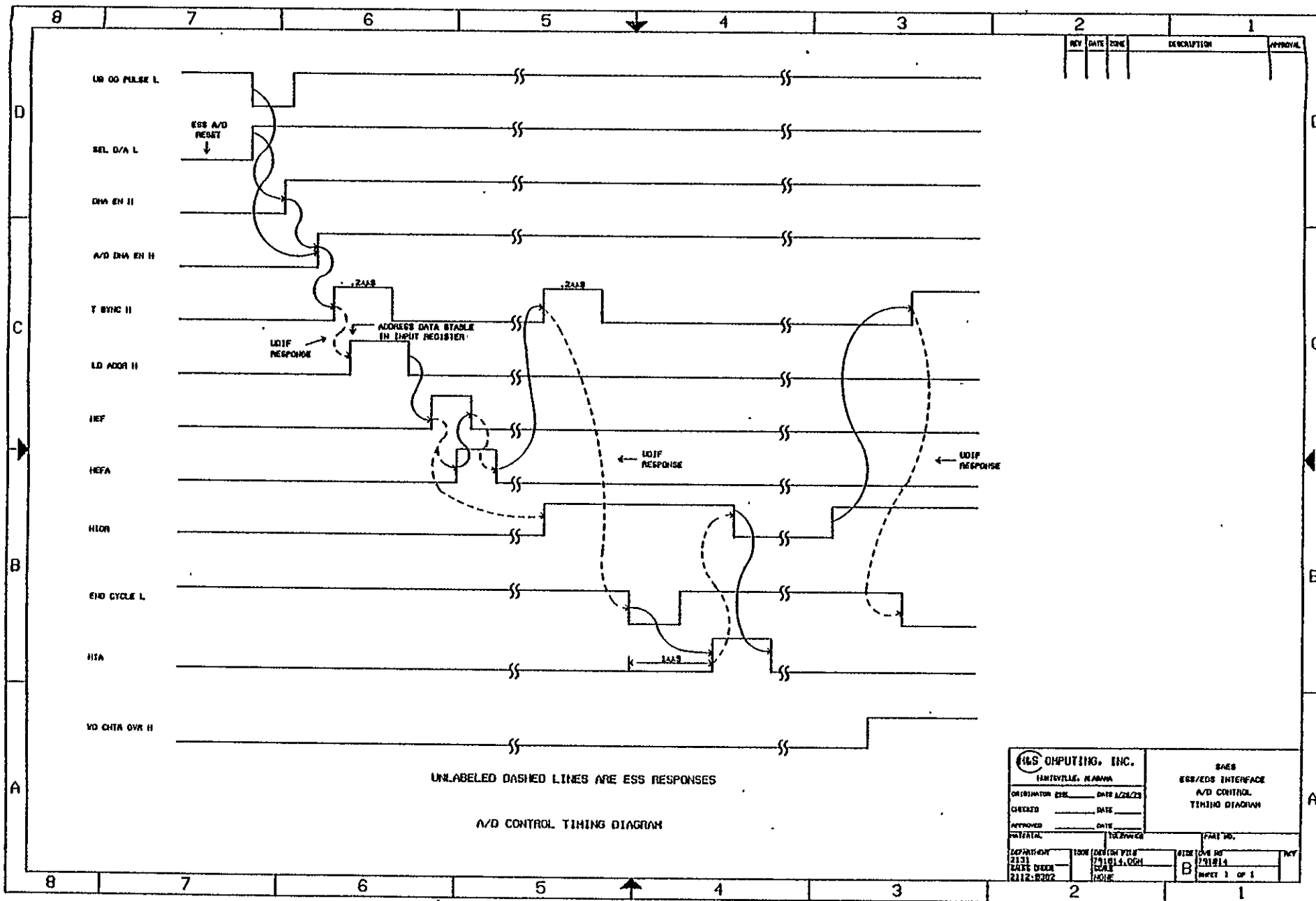

Fig. 3.3.3-1

4.2.3 Transferring Data to the Sigma 560

Figure 4.2.3-1 shows the path data takes when being transferred from the EDS to the Sigma 560. It should be noted that the EDS is slaved to the Sigma 560 as far as transfers are concerned; that is, the Sigma 560 sets the direction in which a transfer is to take place and then initiates the transfer.

Figure 4.2.3-2 shows a timing diagram of two transfers from EDS to Sigma 560. The transfer is initiated by the 7902 subcontroller asserting DATA. The direction which the transfer is to take place is present when this signal is sent. The UDIF will respond to this DATA interrupt by loading one byte of data in the interface card 1 input register. The LD DEST REG H pulse which latches data in the input register also triggers a chain of events which connect service to the 7902 and latch the data there. A transfer is completed when the signal DATA is dropped. Point A on the timing diagram marks where one transfer ends and the next begins.

4.2.4 Transferring Data from the Sigma 560 to the EDS

Figure 4.2.4-1 shows the data path for transferring data from the Sigma 560 to the EDS. In this mode, there may only be one byte of data processed per transfer.

Figure 4.2.4-2 shows a timing diagram of a transfer from the Sigma 560 to the EDS. The transfer is initiated by the 7902 subcontroller asserting DATA. The direction in which the transfer is to take place is present when this signal is sent. The UDIF will respond to this DATA interrupt with a UB GO PULSE H which triggers a chain of events latching data from the 7902 in the interface card 2 input register and then in the UDIF destination register. After data has been latched in the card 2 input register, the transfer is ended by DATA dropping to a low state.

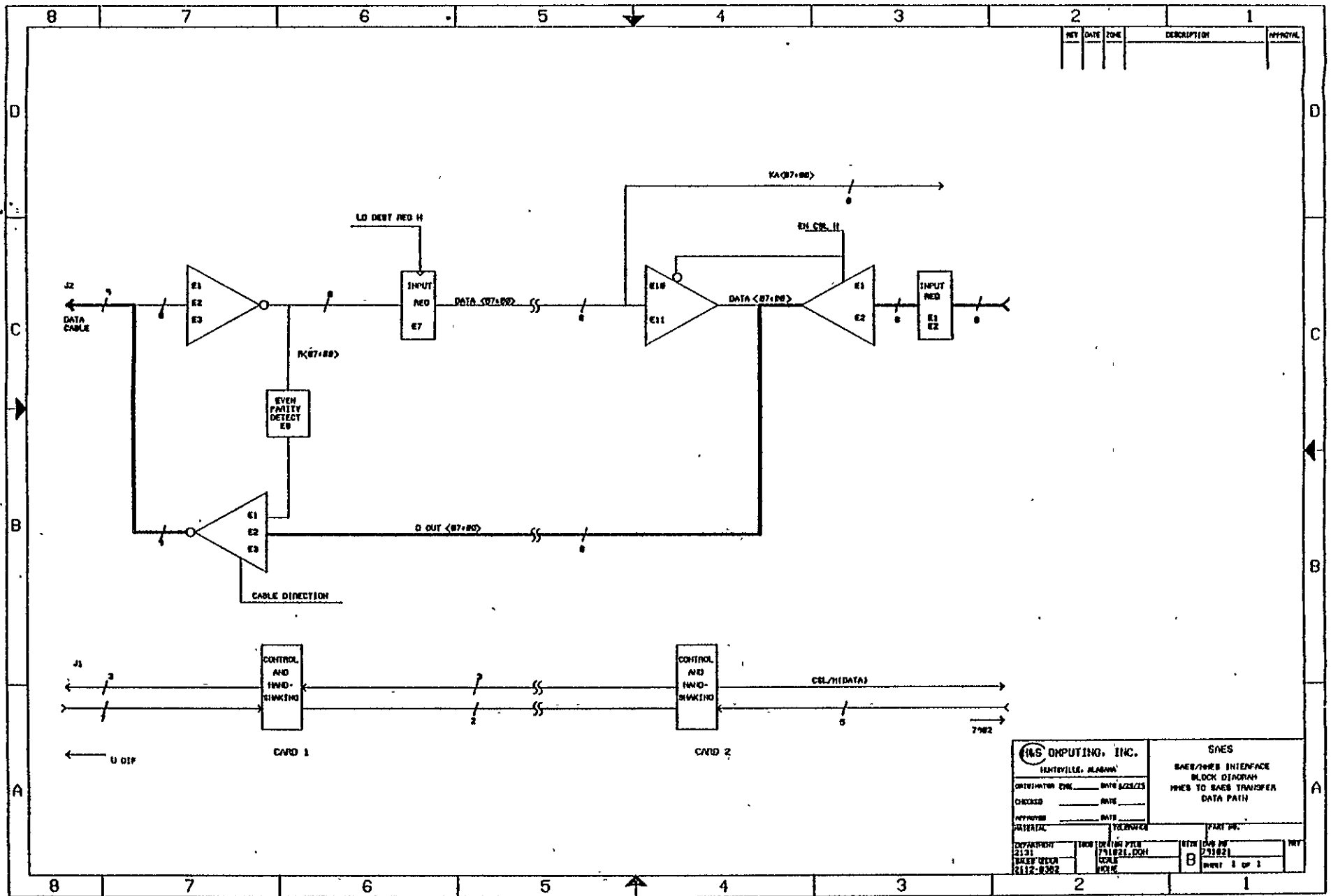

ALS COMPUTING, INC. HUNTSVILLE, ALABAMA		SAES SAES/HSB INTERFACE BLOCK DIAGRAM HWES TO SAES TRANSFER DATA PATH	
ORIGINATOR: EDC CHECKED: _____ APPROVED: _____ INITIAL: _____	DATE: _____ DATE: _____ DATE: _____	PART NO.: _____ REV: _____ SCALE: _____ HOLD: _____	DRAWING NO.: 731821 SHEET: 1 of 1

FIG. 4.2.4-1

APPENDIX A
SCHEMATICS
AND
WIREWRAP LIST

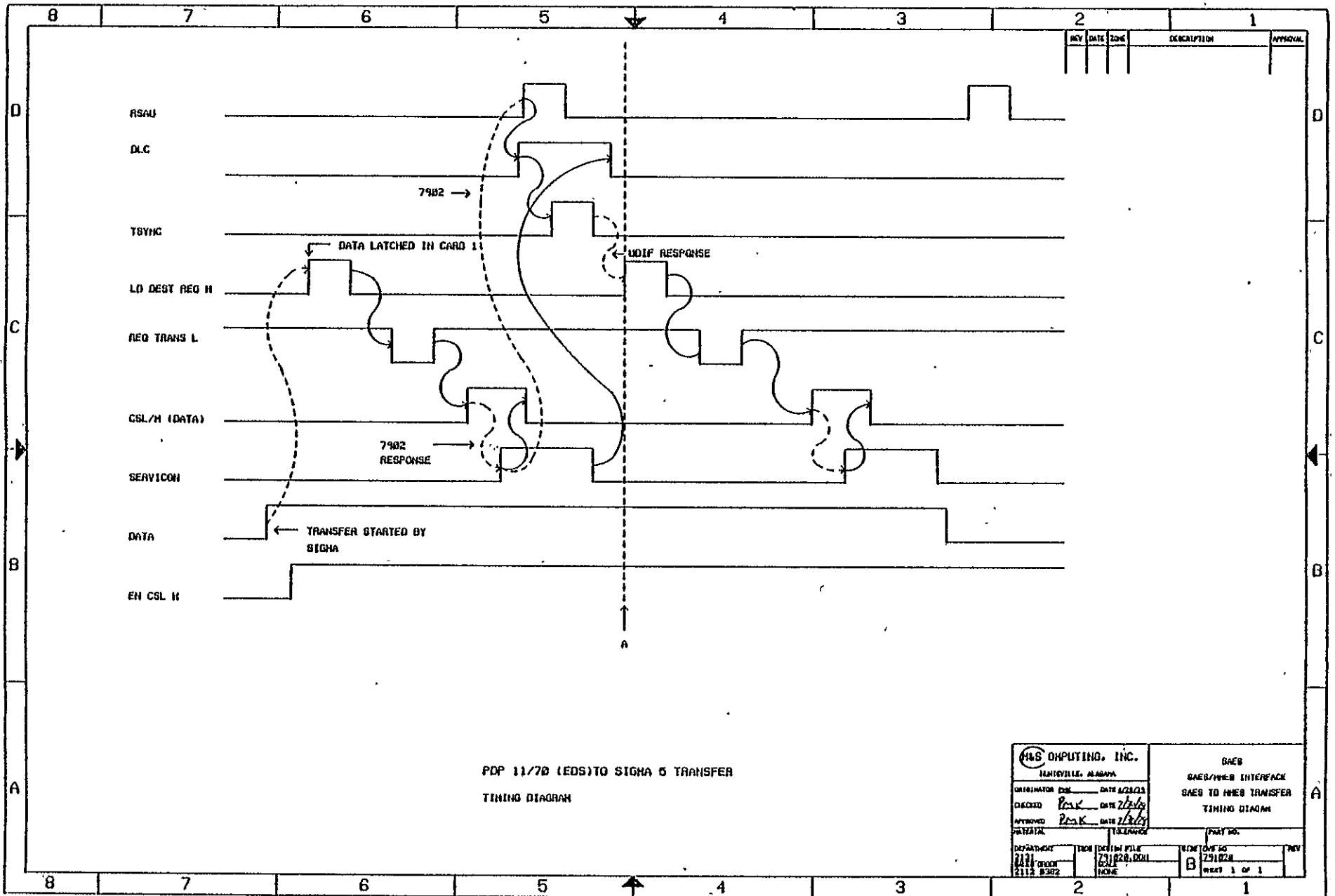

PDP 11/70 (EDS) TO SIGMA 5 TRANSFER
TIMING DIAGRAM

H&S COMPUTING, INC. BIRMINGHAM, ALABAMA		BAES BAES/INHEB INTERFACE BAES TO INHEB TRANSFER TIMING DIAGRAM	
ORIGINATOR: <u>BAE</u> DATE: <u>6/23/73</u>	CHECKED: <u>BAE</u> DATE: <u>7/2/73</u>	APPROVED: <u>BAE</u> DATE: <u>7/2/73</u>	PARTIAL: <input type="checkbox"/>
DEPARTMENT: <u>2112</u> DIVISION: <u>SYSTEMS</u> PROJECT: <u>2112 #302</u>	ITEM: <u>731828.C01</u> TITLE: <u>INHEB</u>	ITEM NO.: <u>B</u> QUANTITY: <u>251824</u>	PART NO.: <u>1</u> SHEET: <u>1 OF 1</u>

GENERAL PAGE IS
OF POOR QUALITY

PODDOUT FRAME

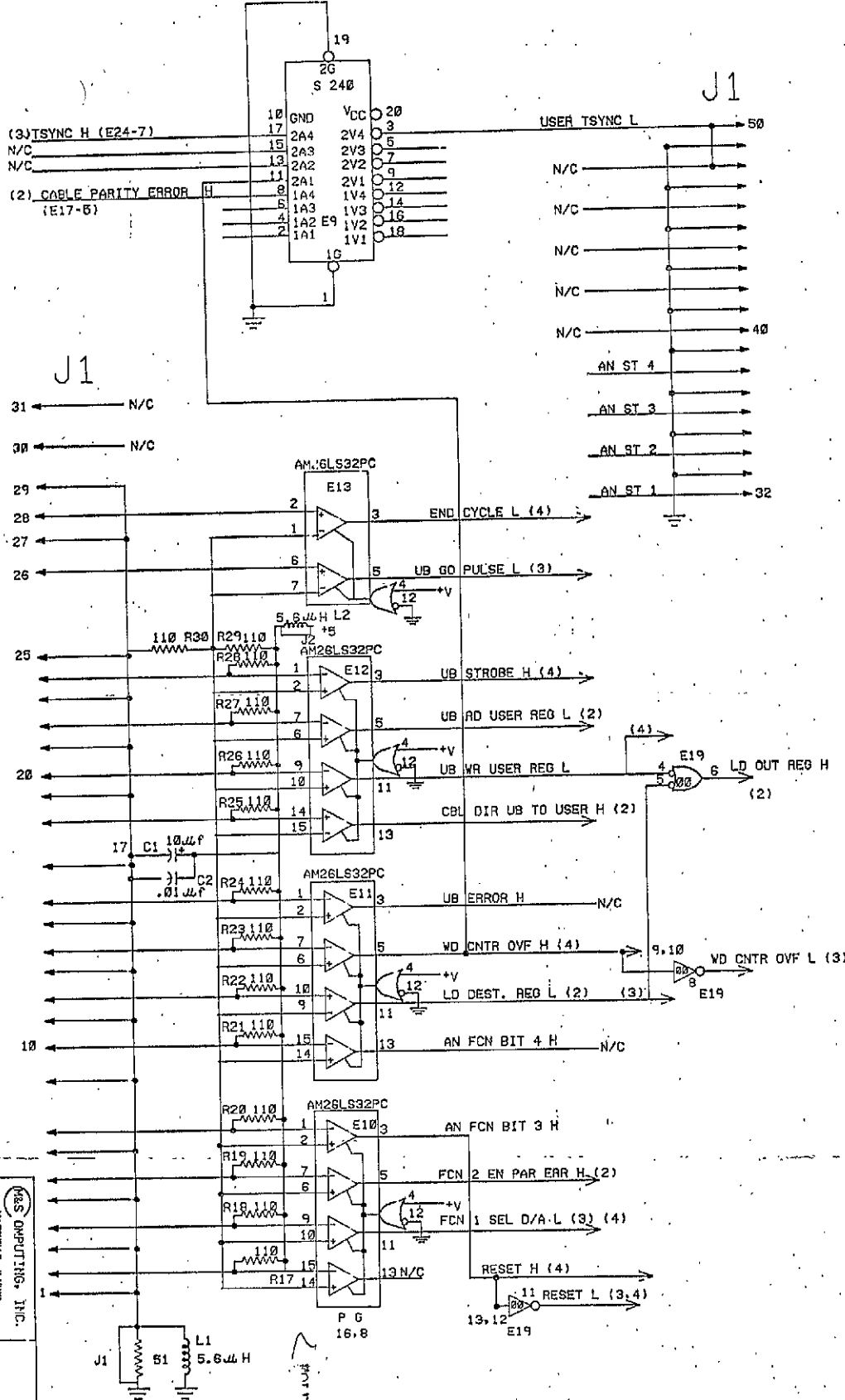

SAES
ESS/ERS INTERFACE
LOGIC DIAGRAM
ESS/FGP 1134 INTERFACE

DESIGNER: HANSHU, M. KAWA
CHECKED: DATE: ANT: GCH/CH
APPROVED: DATE: ANT: T/SS/SS

ISSUE NO. TO: 1000
DATE: 11/13/82
BY: P
SHEET 1 OF 7

REV DATE TIME DESCRIPTION

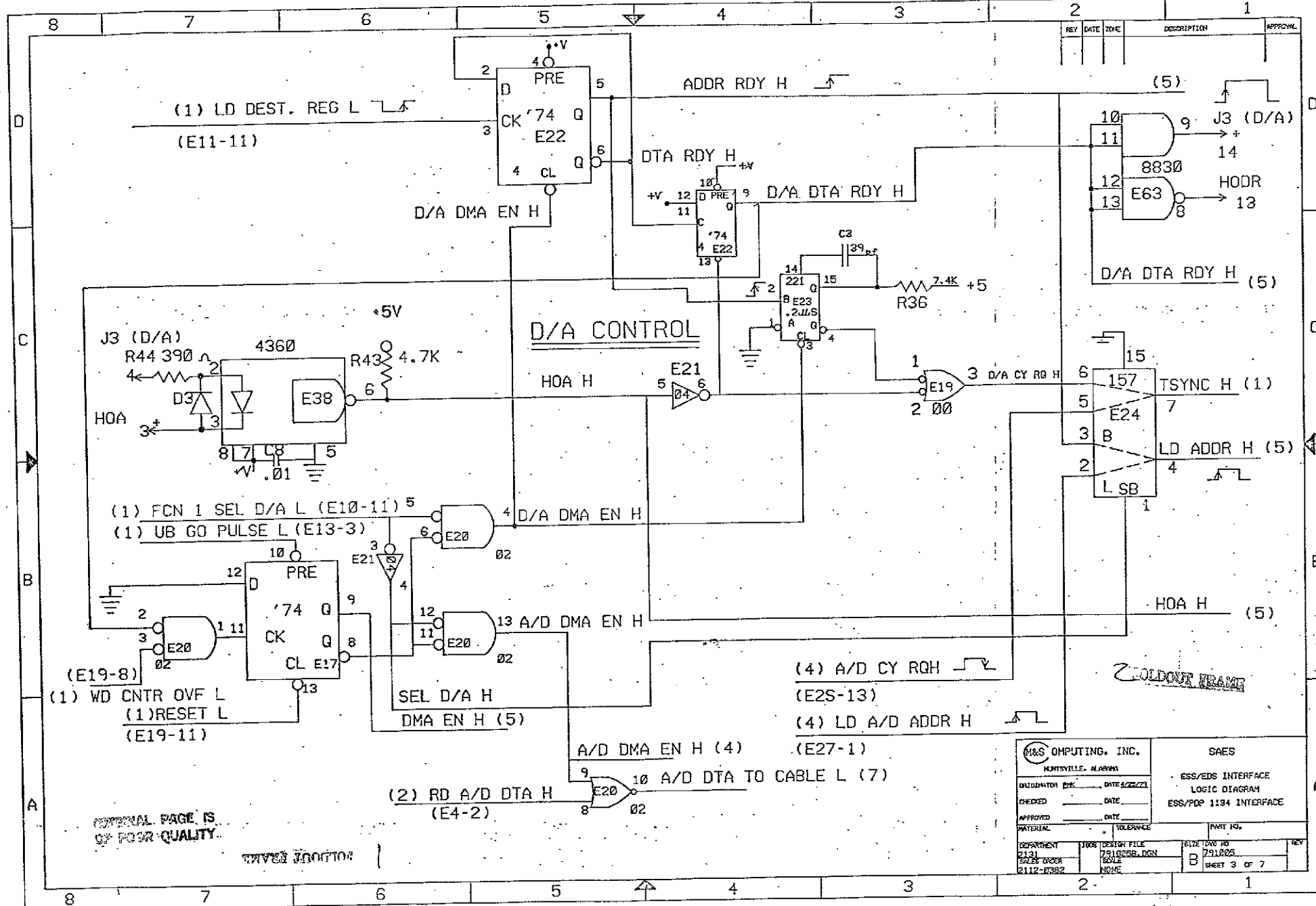

REV	DATE	ZONE	DESCRIPTION	APPROVAL

EXTERNAL PAGE IS
OF POOR QUALITY

M&S COMPUTING, INC. MONTVILLE, ALABAMA		SAES	
ORIGINATOR: [] DATE: []		ESS/EDS INTERFACE	
CHECKED: [] DATE: []		LOGIC DIAGRAM	
APPROVED: [] DATE: []		ESS/PPD 1194 INTERFACE	
MATERIAL: [] TOLERANCE: []		PART NO. []	
DEPARTMENT: []	JOB: []	DESIGN FILE: []	FILE: []
SALES ORDER: []	PRICE: []	DATE: []	NO: []

WILDOUT FRAME

REV	DATE	ZONE	DESCRIPTION	APPROVAL

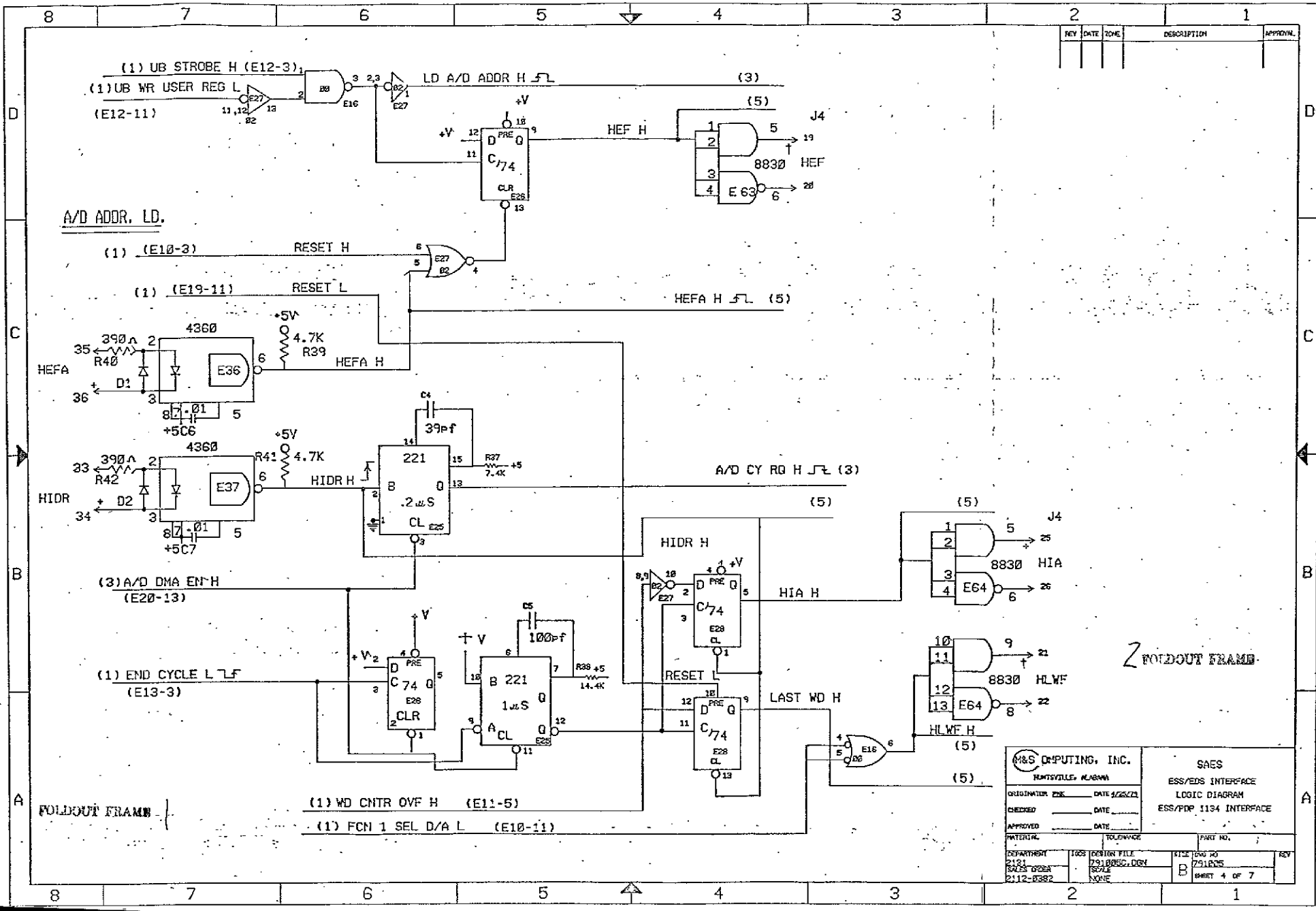

Z FOLDOUT FRAME

M&S COMPUTING, INC. BENTONVILLE, ALABAMA		SAES	
ORIGINATOR P#K _____ DATE 1/25/71		ESS/EDS INTERFACE	
CHECKED _____ DATE _____		LOGIC DIAGRAM	
APPROVED _____ DATE _____		ESS/PDP 1134 INTERFACE	
MATERIAL _____ TELEPHONE _____		PART NO. _____	
DEPARTMENT 2112	TITLE DESIGN FILE 7511BSC.D01	SIZE 8 1/2 X 11	REV 7511BSC
SALES 0324	SCALE NONE	DATE 1/25/71	SHEET 4 OF 7
2112-0382			

D/A & A/D ADDRESS

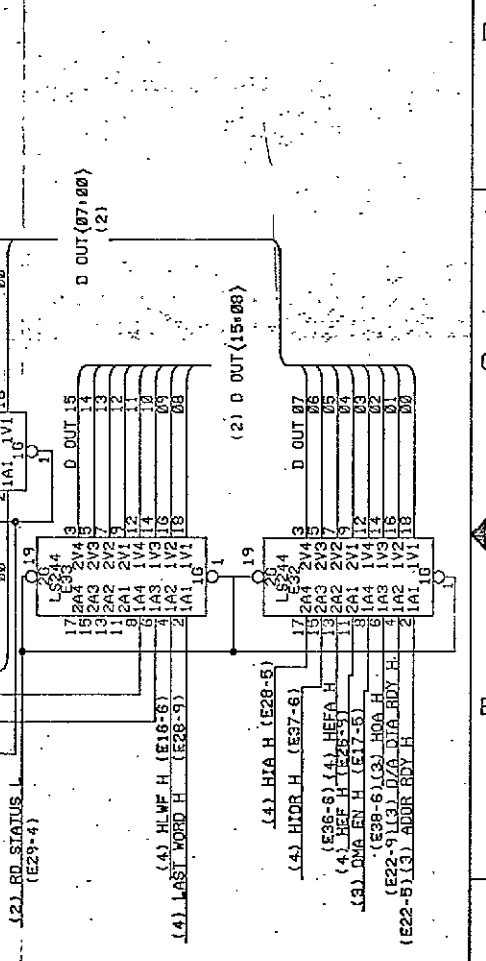
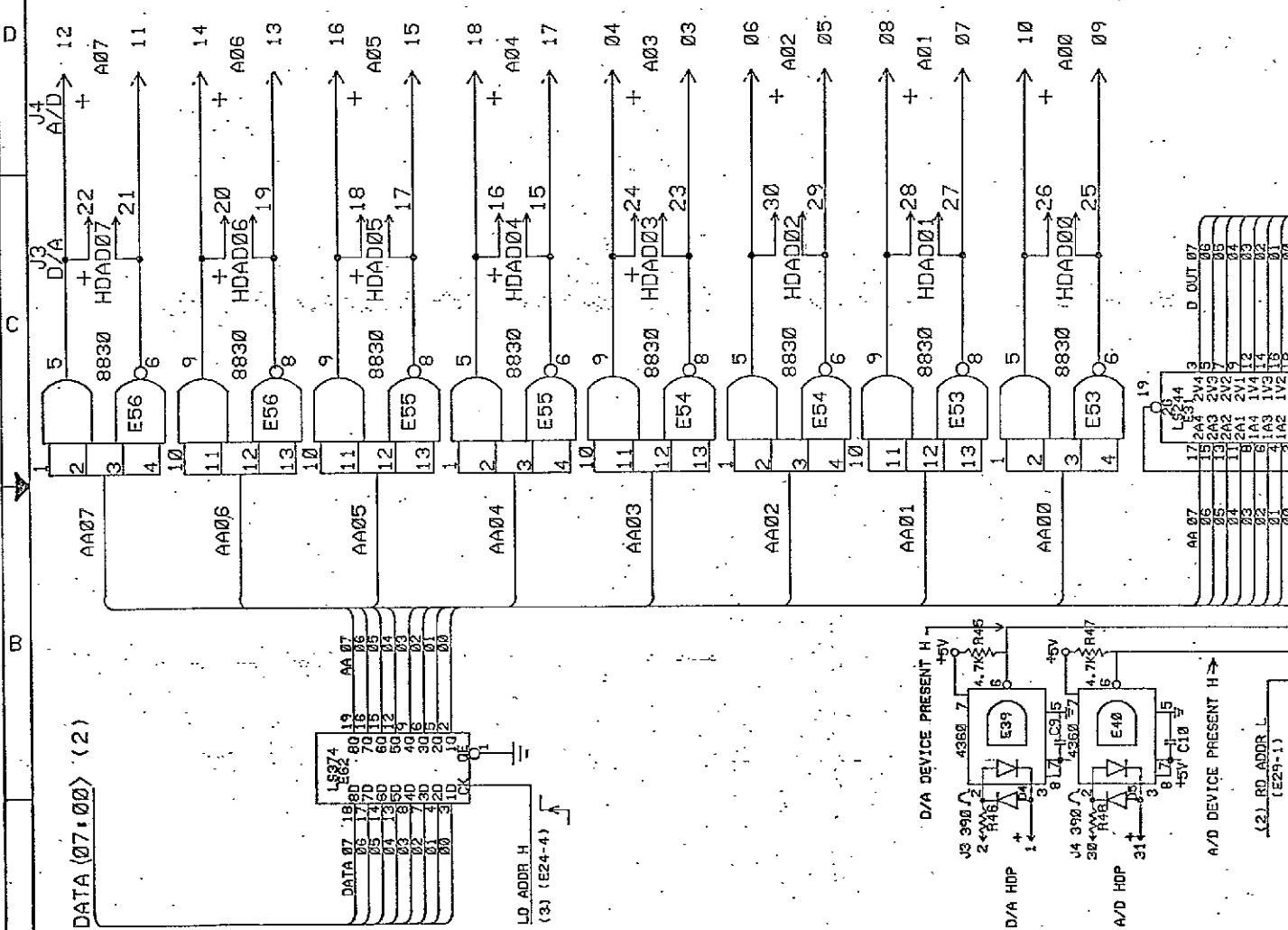

REV	DATE	ZONE	DESCRIPTION	APPROVAL

M&S COMPUTING, INC.		SAES	
MONTVILLE, ALABAMA		ESS/EDS INTERFACE	
ORIGINATOR: DK		DATE: 2/22/72	
DESIGNED: 		DATE: 	
APPROVED: 		DATE: 	
PARTIAL: 		TOLERANCE: 	
DEPARTMENT: 1005		DESIGNER: FILE	
DRAWN: ORDER		SCALE: NONE	
2112-8382		SHEET: 5 OF 7	

NO. 10047-1

2 FOLDOUT FRAME

REV	DATE	ZONE	DESCRIPTION	APPROVAL

D/A DATA WORD

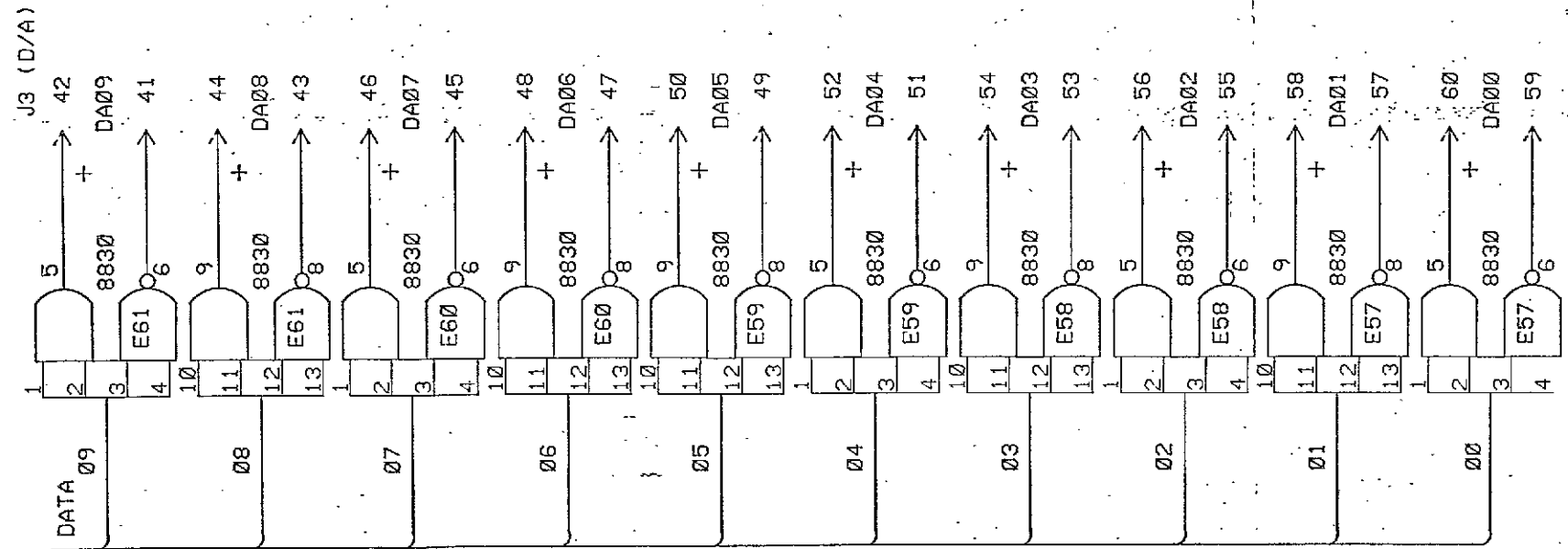

DATA 09: 000
(2)

2 FOLDOUT FRAME

FOLDOUT FRAME

M&S COMPUTING, INC. HUNTSVILLE, ALABAMA		SAES ESS/EDS INTERFACE LOGIC DIAGRAM ESS/PDP 1134 INTERFACE	
DESIGNATOR: PHE	DATE: 6/22/71		
CHECKED: _____	DATE: _____		
APPROVED: _____	DATE: _____		
PARTIAL: _____	TELEPHONE: _____	PART NO.: _____	
DEPARTMENT: 2131	DESIGN FILE: 731PCE_DCN	SHEET NO: B	REV: 731005
PROJECT NUMBER: 2112-8382	SCALE: NONE	SHEET 6 OF 7	

REV	DATE	ZONE	DESCRIPTION	APPROVAL

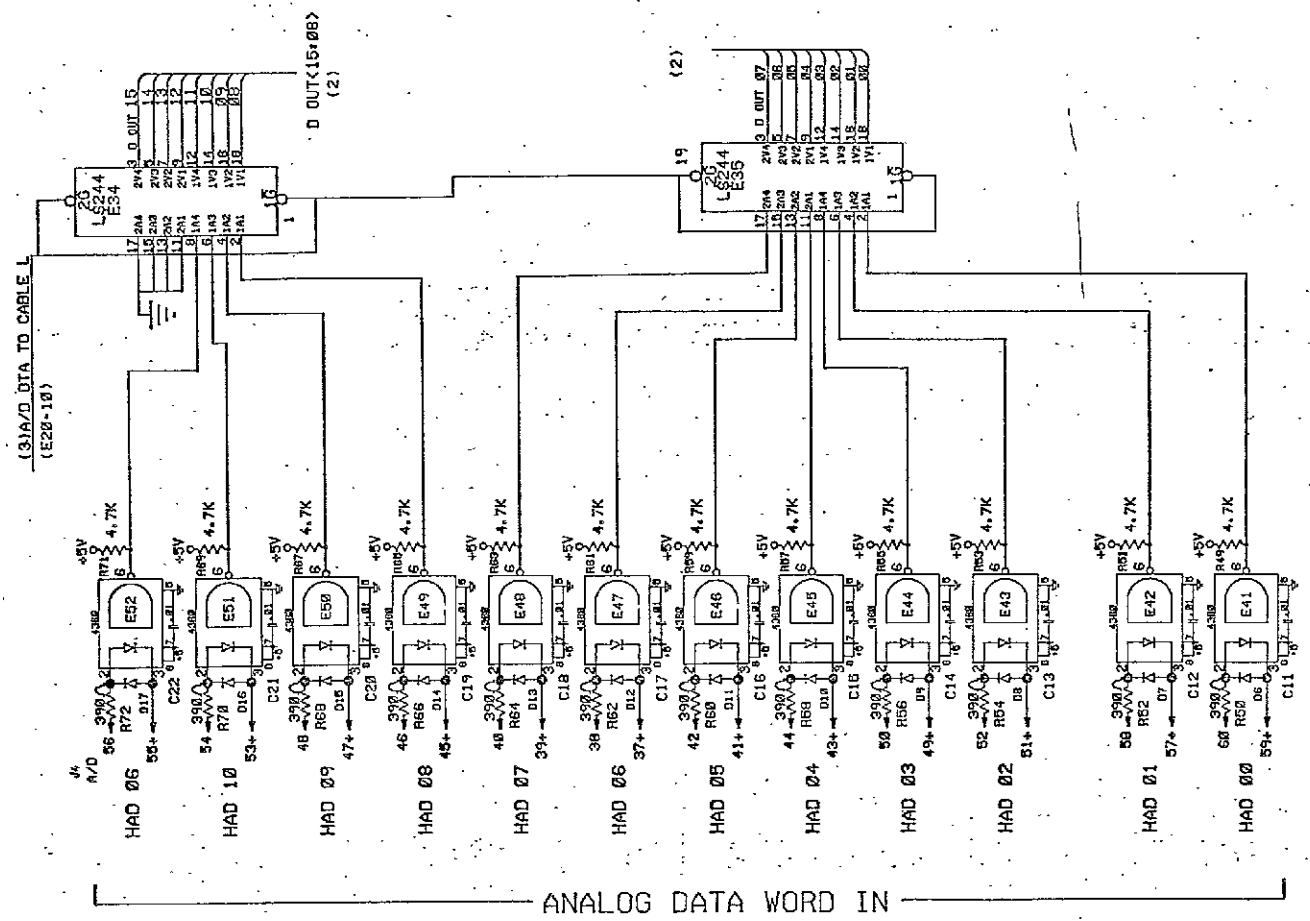

FOLDOUT FRAME

ORIGINAL PAGE IS
OF POOR QUALITY

2 FOLDOUT FRAME

M&S COMPUTING, INC. HUNTSVILLE, ALABAMA		SAES ESS/EDS INTERFACE LOGIC DIAGRAM ESS/PDP 1134 INTERFACE	
ORIGINATOR: ENK CHECKED: _____ APPROVED: _____ MATERIAL: _____	DATE: 5/28/73 DATE: _____ DATE: _____ TOLERANCE: _____	PART NO. 2112-1000-00 2112-0255-00N SCALE: NONE	REV: _____ 2112-1000-00 2112-0255 SHEET 7 OF 7

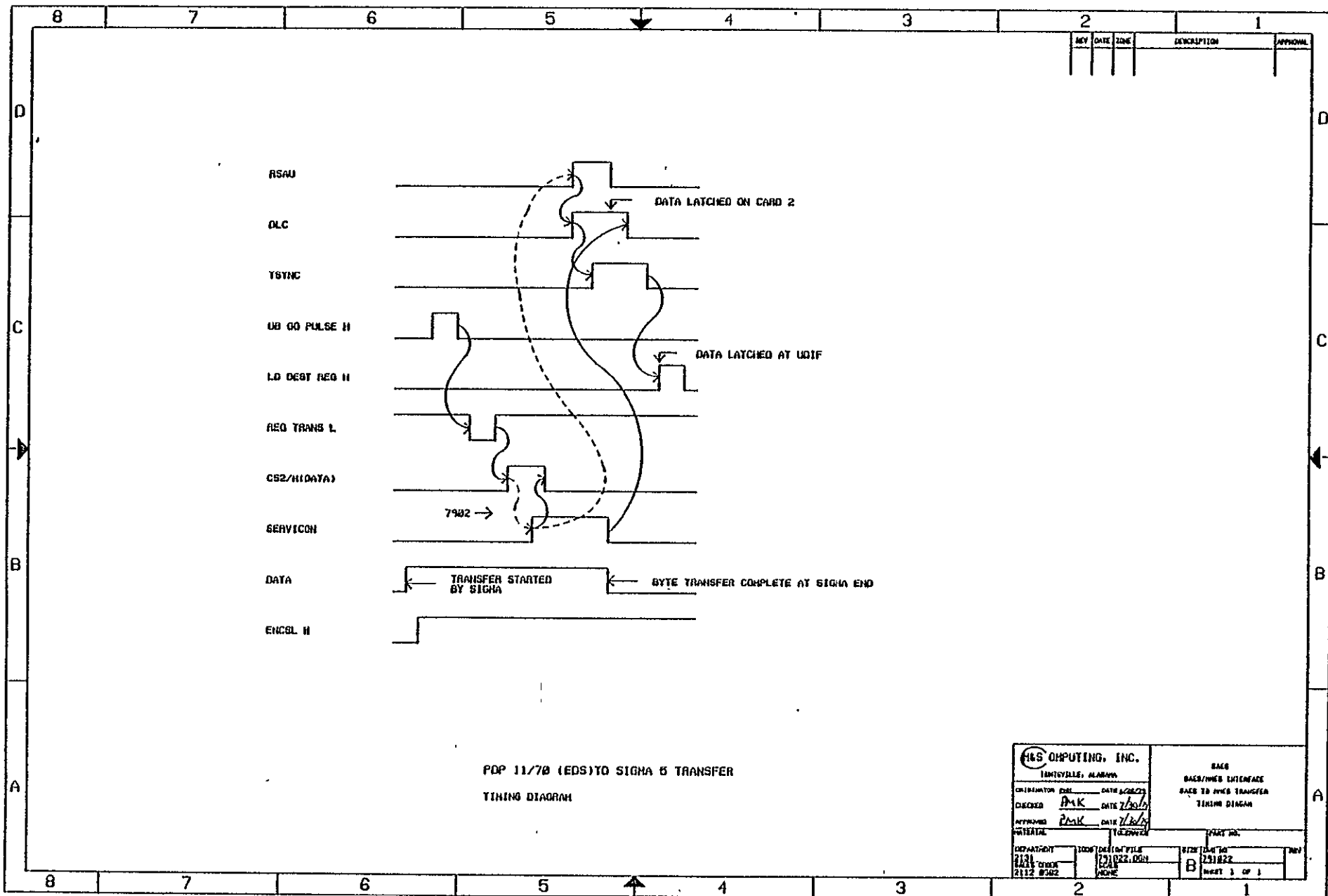

FIGS COMPUTING, INC. TAMPSVILLE, ALABAMA		PAGE BASED ON THE LITERATURE BASED TO THE TRANSFER TIMING DIAGRAM	
ORIGINATOR: EBL	DATE: 7/30/67		
CHECKED: <i>PAK</i>	DATE: 7/30/67		
APPROVED: <i>PAK</i>	DATE: 7/30/67		
INITIALS:	TELEPHONE:	PART NO.:	
DEPARTMENT: 2112	LOCATION: 2112 B362	SIZE: B	DATE: 7/31/67
2112 B362		PAGE 3 OF 3	

FIG. 4.2.4-2

SAES
ESS/EDS INTERFACE
LAYOUT
WIREWAP LIST

A-9

PRECEDING PAGE BLANK NOT FILMED

PART NO.	VALUE / TYPE	LOCATION
E1	74LS373	LL-1
E2	74LS373	LL-13
E3	74LS244	LL-25
E4	74LS244	LL-37
E5	8641	JJ-1
E6	8641	JJ-16
E7	8641	JJ-32
E8	8641	JJ-48
E9	74S240	LL-49
E10	AM26LS32PC	FF-1
E11	AM26LS32PC	FF-16
E12	AM26LS32PC	FF-32
E13	AM26LS32PC	FF-48
E14	74S280	DD-1 *
E15	74S280	DD-10
E16	7400	DD-A
E17	7474	DD-28
E18	8641	DD-46
E19	7400	FF-57
E20	7402	DD-37
E21	7404	BB-58
E22	7474	BB-49
E23	74221	BB-39
E24	74157	BB-26
E25	74221	BB-13
E26	7474	BB-1
E27	7402	Z-1
E28	7474	Z-10
E29	7442	Z-19
E30	—————	—————
E31	74S244	W-1
E32	74S244	W-13
E33	74S244	W-25
E34	74S244	W-37

PART NO.	VALUE / TYPE	LOCATION
E35	74S244	W-49
E36	4360	U-18(U-59)
E37	4360	U-28(U-49)
E38	4360	U-38(U-39)
E39	4360	U-48(U-29)
E40	4360	U-58(U-19)
E41	4360	K-58
E42	4360	K-48
E43	4360	K-38
E44	4360	K-28
E45	4360	K-18
E46	4360	K-Ø8
E47	4360	H-58
E48	4360	H-48
E49	4360	H-38
E50	4360	H-28
E51	4360	H-18
E52	4360	H-Ø8
E53	8830	M-57
E54	8830	M-49
E55	8830	M-41
E56	8830	M-33
E57	8830	M-25
E58	8830	M-17
E59	8830	M-9
E60	8830	M-1
E61	8830	P-1
E62	74LS374	E-1
E63	8830	Z-38
E64	8830	Z-29

SEE NOTE

* INSTALLED BACKWARDS ON SN1
NOTE: PINS ARE INDICATED FOR SN2, SN1 DIFFERS AS NOTED

PART NO.	VALUE / TYPE	LOCATION
R1	180	JJ-10
R2	110	JJ-11
R3		JJ-12
R4		JJ-13
R5		JJ-26
R6		JJ-27
R7		JJ-28
R8		JJ-29
R9		JJ-42
R10		JJ-43
R11		JJ-44
R12		JJ-45
R13		JJ-57
R14		JJ-58
R15		JJ-59
R16	110	JJ-60
R17		FF-10
R18		FF-11
R19		FF-12
R20		FF-13
R21		FF-26
R22		FF-27
R23		FF-28
R24		FF-29
R25		FF-42
R26		FF-43
R27		FF-44
R28		FF-45
R29		JJ-61
R30	110	JJ-62
R31	51	JJ-64
R32	110	DD-56
R33		DD-57
R34		DD-58

PART NO.	VALUE / TYPE	LOCATION
R35	110	DD-59
R36	7.15K 1% 1/8wt	BB-37
R37	7.15K 1% 1/8wt	BB-24
R38	15K 1% 1/8wt	BB-11
R39	4.7K	U-23(U-64)
R40	390	U-16(U-57)
R41	4.7K	U-33(U-54)
R42	390	U-26(U-47)
R43	4.7K	U-43(U-44)
R44	390	U-36(U-37)
R45	4.7K	U-53(U-34)
R46	390	U-46(U-27)
R47	4.7K	U-63(U-24)
R48	390	U-56(U-27)
R49	4.7K	K-63
R50	390	K-56
R51	4.7K	K-53
R52	390	K-46
R53	4.7K	K-43
R54	390	K-36
R55	4.7K	K-33
R56	390	K-26
R57	4.7K	K-23
R58	390	K-16
R59	4.7K	K-13
R60	390	K-06
R61	4.7K	H-63
R62	390	H-56
R63	4.7K	H-53
R64	390	H-46
R65	4.7K	H-43
R66	390	H-36
R67	4.7K	H-33
R68	390	H-26

S22
A213

PART NO.	VALUE / TYPE	LOCATION
R69	4.7K	H-23
R70	390	H-16
R71	4.7K	H-13
R72	390	H-06
D1	4484	U-17(U-58)
D2		U-27(U-48)
D3		U-37(U-38)
D4		U-47(U-28)
D5		U-57(U-18)
D6		K-57
D7		K-47
D8		K-37
D9		K-27
D10		K-17
D11		K-07
D12		H-57
D13		H-47
D14		H-37
D15		H-27
D16		H-17
D17		H-07
C1	10 μ f 25V TANT	NN-64
C2	.1 μ f 200V disc	NN-62
C3	39 pF 200V disc	BB-35
C4	39 pF 200V disc	BB-22
C5	100 pF 200V disc	BB-9
C23	10 μ f 25V TANT	DD-64
C24	.1 μ f 200V disc	DD-62

A-14

PART NO.	VALUE / TYPE	LOCATION
bypass	.1 μ f 200V	LL-11
		LL-35
		JJ-25
		JJ-41
		FF-25
		FF-41
		BB-8
		BB-34
		BB-56
		Z-17
		Z-36
		W-23
		W-47
		U-24
		J-34
		J-44
		J-54
		J-64
		M-16
		M-32
		M-48
		K-14
		K-24
		K-34
		K-44
		K-54
		K-64
		H-14
		H-24
		H-34
		H-44
		H-54
		H-64
		DD-17
		DD-35

DD-35

START: To:

PAGE # 7

GROUND BUS

J1(33,35,37,39,41,43,45,47,49)

J2(ODD)

E1-1, E1-10, LL-11, E2-1, E2-10, E3-10, LL-35, E4-10, E9-19, E9-1, E9-10

E5-8, E6-8, JJ-25, E7-8, JJ-41, E8-8, JJ-64

E10-12, E10-8, E11-12, E11-8, FF-25, E12-12, E12-8, E13-12, E13-8, E19-7

E14-7, E15-7, DD-17, E16-7, E17-12, E17-7, DD-35, E20-7, E18-14, E18-11

E18-8, E18-5

E26-7, BB-8, E25-1, E25-8, E24-15, E24-8, BB-34, E23-1, E23-8

E22-7, BB-56, E21-7

E27-7, E28-7, Z-17, E29-8, E64-7, Z-36, E63-7

E31-10, E32-10, W-23, E33-10, E34-17, E34-15, E34-13, E34-11

E34-10, W-47, E35-10

START:

TO:

PAGE # 8

GROUND BUS : CONTINUED

E36-5, U-24, E37-5, U-34, E38-5, U-44, E39-5, U-54

E40-5, U-64

E61-7

E60-7, E59-7, M-16, E58-7, E57-7, M-32, E56-7, E55-7, M-48,

E54-7, E53-7

E46-5, K-14, E45-5, K-24, E44-5, K-34, E43-5, K-44, E42-5,

K-54, E41-5, K-64

E52-5, H-14, E51-5, H-24, E50-5, H-34, E49-5, H-44, E48-5, H-54

E47-5, H-64

E62-1, E62-10

ORIGINAL PAGE IS
OF POOR QUALITY

START:

To:

PAGE #9

+5 Bus

E1-20, MM-11, E2-20, E3-20, MM-35, E4-20, E9-20

ES-16, KK-10, KK-11, KK-12, KK-13, E6-16, KK-25, KK-26, KK-27, KK-28, KK-29,
E7-16, KK-41, KK-42, KK-43, KK-44, KK-45, E8-16, KK-57, KK-58, KK-59
KK-60, KK-61

NN-64, NN-62

E10-16, E10-4, HH-10, HH-11, HH-12, HH-13, E11-16, E11-4, HH-25, HH-26
HH-27, HH-28, HH-29, E12-16, E12-4, HH-41, HH-42, HH-43, HH-44,
HH-45, E13-16, E13-4, E19-14

E14-14, E15-14, EE-17, E16-14, E17-14, EE-35, E20-14, E18-16,
EE-56, EE-57, EE-58, EE-59, EE-62, EE-64

E26-2, E26-4, E26-14, E26-12, E26-10, CC-8, CC-11, E25-16, E25-10
CC-24, E24-16, CC-34, CC-37, E23-16, E22-4, E22-14, E22-12,
E22-10, CC-56, E21-14

E27-14, E28-4, E28-14, AA-17, E29-16, E64-14, AA-36, E63-14

E31-20, E32-20, Y-23, E33-20, E34-20, Y-47, E35-20

START:

To:

PAGE #10

+5 Bus: CONTINUED

E36-8, E36-7, V-23, V-24, E37-8, E37-7, V-33, V-34, E38-8, E38-7

V-43, V-44, E39-8, E39-7, V-53, V-54, E40-8, E40-7, V-63, V-64

E61-14

E60-14, E59-14, N-16, E58-14, E57-14, N-32, E56-14, E55-14,

N-48, E54-14, E53-14

E46-8, E46-7, L-13, L-14, E45-8, E45-7, L-23, L-24, E44-8, E44-7,

L-33, L-34, E43-8, E43-7, L-43, L-44, E42-8, E42-7, L-53, L-54

E41-8, E41-7, L-63, L-64

E52-8, E52-7, J-13, J-14, E51-8, E51-7, J-23, J-24, E50-8, E50-7, J-33,

J-34, E49-8, E49-7, J-43, J-44, E48-8, E48-7, J-53, J-54,

E47-8, E47-7, J-63, J-64

E62-20

LATCHED ADDR BUS

START: To:

PAGE# 13

AA00 E62-2	E53(1,2,3,4), E31-2	Sht. 5 ↓
AA01 E62-5	E53(10,11,12,13), E31-4 ✓	
AA02 E62-6	E54(1,2,3,4), E31-6 ✓	
AA03 E62-9	E54(10,11,12,13), E31-8 ✓	
AA04 E62-12	E55(1,2,3,4), E31-11 ✓	
AA05 E62-15	E55(10,11,12,13), E31-13 ✓	
AA06 E62-16	E56(10,11,12,13), E31-15 ✓	
AA07 E62-19	E56(1,2,3,4), E31-17 ✓	

A/D DATA IN

PAGE # 15

S.K. 7

START:

TO:

⁰⁰E41-6 R49-K, E35-2 ✓ ✓

⁰¹E42-6 R51-K, E35-4 ✓ ✓

⁰²E43-6 R53-K, E35-6 ✓ ✓

⁰³E44-6 R55-K, E35-8 ✓ ✓

⁰⁴E45-6 R57-K, E35-11 ✓ ✓

⁰⁵E46-6 R59-K, E35-13 ✓ ✓

⁰⁶E47-6 R61-H, E35-15 ✓ ✓

⁰⁷E48-6 R63-H, E35-17 ✓ ✓

⁰⁸E49-6 R65-H, E34-2 ✓ ✓

⁰⁹E50-6 R67-H, E34-4 ✓ ✓

¹⁰E51-6 R69-H, E34-6 ✓ ✓

¹¹E52-6 R71-H, E34-8 ✓ ✓

Control/UB

J2

2/2

START: To:

PAGE # 16

R1-JJ	E5-1, J2/40 ✓
R2-JJ	E5-4, J2/38 ✓
R3-JJ	E5-12, J2/36 ✓
R4-JJ	E5-15, J2/34 ✓
R5-JJ	E6-1, J2/32 ✓
R6-JJ	E6-4, J2/30 ✓
R7-JJ	E6-12, J2/28 ✓
R8-JJ	E6-15, J2/26 ✓
R9-JJ	E7-1, J2/24 ✓
R10-JJ	E7-4, J2/22 ✓
R11-JJ	E7-12, J2/20 ✓
R12-JJ	E7-15, J2/18 ✓
R13-JJ	E8-1, J2/16 ✓
R14-JJ	E8-4, J2/14 ✓
R15-JJ	E8-12, J2/12 ✓
R16-JJ	E8-15, J2/10 ✓
R32-DD	E18-1, J2/8 ✓
R33-DD	E18-4, J2/6 ✓
R34-DD	E18-12, J2/4 ✓
R35-DD	E18-15, J2/2 ✓
C24-DD	C23-DD, J2/23 ✓
NN-31	J2/1 thru 39 (ODD) ✓
R	- ERD
	COL/PIN

D/A DATA

START: To:

E57-6	J3/59 ✓	DA00
E57-5	J3/60 ✓	
E57-8	J3/57 ✓	DA01
E57-9	J3/58 ✓	
E58-6	J3/55 ✓	DA02
E58-5	J3/56 ✓	
E58-8	J3/53 ✓	DA03
E58-9	J3/54 ✓	
E59-6	J3/51 ✓	DA04
E59-5	J3/52 ✓	
E59-8	J3/49 ✓	DA05
E59-9	J3/50 ✓	
E60-8	J3/47 ✓	DA06
E60-9	J3/48 ✓	
E60-6	J3/45 ✓	DA07
E60-5	J3/46 ✓	
E61-8	J3/43 ✓	DA08
E61-9	J3/44 ✓	
E61-6	J3/41 ✓	DA09
E61-5	J3/42 ✓	

ANALOG DATA WORD IN

START:	To:	PAGE#
D6-L	E41-3, J4/59 ✓✓	19 7/18, 7
R50-L	J4/60 ✓✓	HAD 00
R50-K	D6-K, E41-2 ✓✓	
D7-L	E42-3, J4/57 ✓✓	
R52-L	J4/58 ✓✓	HAD 01
R52-K	D7-K, E42-2 ✓✓	
D8-L	E43-3, J4/51 ✓✓	
R54-L	J4/52 ✓✓	HAD 02
R54-K	D8-K, E43-2 ✓✓	
D9-L	E44-3, J4/49 ✓✓	
R56-L	J4/50 ✓✓	HAD 03
R56-K	D9-K, E44-2 ✓✓	
D10-L	E45-3, J4/43 ✓✓	
R58-L	J4/44 ✓✓	HAD 04
R58-K	D10-K, E45-2 ✓✓	
D11-L	E46-3, J4/41 ✓✓	
R60-L	J4/42 ✓✓	HAD 05
R60-K	D11-K, E46-2 ✓✓	
D12-J	E47-3, J4/37 ✓✓	
R62-J	J4/38 ✓✓	HAD 06
R62-H	D12-H, E47-2 ✓✓	
D13-J	E48-3, J4/39 ✓✓	
R64-J	J4/40 ✓✓	HAD 07
R64-H	D13-H, E48-2 ✓✓	
D14-J	E49-3, J4/45 ✓✓	
R66-J	J4/46 ✓✓	HAD 08
R66-H	D14-H, E49-2 ✓✓	

A/D & D/A I/F CONTROL

START:	To:		
D5-V	E40-3, J4/31 ✓		
R48-V	J4/30 ✓	A/D HDP	Fig. 3
R48-U	D5-U, E40-2 ✓		
D4-V	E39-3, J3/1 ✓		
R46-V	J3/2 ✓	D/A HDP	Fig. 5
R46-U	D4-U, E39-2 ✓		
D3-V	E38-3, J3/3 ✓		
R44-V	J3/4 ✓	HOA (D/A)	Fig. 3
R44-U	D3-U, E38-2 ✓		
D2-V	E37-3, J4/34 ✓		
R42-V	J4/33 ✓	HIDR	Fig. 4
R42-U	D2-U, E37-2 ✓		
D1-V	E36-3, J4/36 ✓		
R40-V	J4/35 ✓	HEFA	Fig. 4
R40-U	D1-U, E36-2 ✓		
E63-8	J3/13 ✓	HCDR (D/A)	Fig. 3
E63-9	J3/14 ✓		
E63-6	J4/20 ✓	HEF (A/D)	Fig. 4
E63-5	J4/19 ✓		
E64-8	J4/22 ✓	HLFW	Fig. 4
E64-9	J4/21 ✓		
E64-6	J4/26 ✓	HIA	Fig. 4
E64-5	J4/25 ✓		

CONTROL LOGIC

START:	To:	PAGE#
	END CYCLE L	22
E13-3	E26-3 ✓	22, 1, 4
	LB GO PULSE L	22, 1, 3
E13-5	E17-10 ✓	
	LB STROBE H	22, 1, 4
E12-3	E16-1 ✓	
	LB RD USER REG. L	22, 1, 2
E12-5	E29-12 ✓	
	LB WR USER REG L	22, 1, 4
E12-11	E19-4, E27-11, E27-12 ✓	
	CBL DIR LB TO USER H	22, 1, 2
E12-13	E18-7, E18-9, E16-12, E16-9, E8-7, E8-9, E7-7, E7-9 E6-7, E6-9, E5-7, E5-9 ✓	
	WD CNTR OVF H	22, 1, 4
E11-5	E19-9, E19-10, E28-12, E27-8, E27-9	
	WD CNTR OVF L	22, 1, 3
E19-8	E31-3 ✓	
	LD OUT REG H	22, 1, 2
E19-6	E1-11, E2-11 ✓	

ORIGINAL PAGE IS
OF POOR QUALITY

START: To:

PAGE# 24

R30-KK R31-KK, L1-MIII, C1-PP, C2-PP, J1/17 ✓

J1/15, J1/13, J1/11, J1/9, J1/7, J1/5, J1/3, J1/1

J1/19, J1/21, J1/23, J1/25, J1/27, J1/29 ✓

C2-NN C1-NN, L2-LL, R29-KK, R17 thru R28 (HH) ✓

R30-JJ R29-JJ, E13-1, E13-9, E12-2, E12-6, E12-10, E12-15, E11-2 ✓
 E11-6, E11-9, E11-14, E10-2, E10-6, E10-10, E10-14 ✓

E13-2 J1/28 ✓

E13-6 J1/26 ✓

E10-15 R17-FF, J1/2 ✓

E10-9 R18-FF, J1/4 ✓

E10-7 R19-FF, J1/6 ✓

E10-1 R20-FF, J1/8 ✓

E11-15 R21-FF, J1/10 ✓

E11-10 R22-FF, J1/12 ✓

E11-7 R23-FF, J1/14 ✓

E11-1 R24-FF, J1/16 ✓

E12-14 R25-FF, J1/18 ✓

E12-9 R26-FF, J1/20 ✓

E12-7 R27-FF, J1/22 ✓

E13-1 R28-FF, J1/24 ✓

LIB CONTROL (31)

Sheet 1

START: To:

PAGE # 25

RR-31 J1/33, J1/35, J1/37, J1/39, J1/41, J1/43, J1/45, J1/47, J1/49

GRD BUS

COLUMN/PIN

E9-3 J1/50 ✓✓

E9-12 J1/32 ✓ CABLE Parity ERROR LINE TO UDIF, NOT INSTALLED

L1-LL L1-MM / intentional shorting of components

L2-LL L2-MM /

Control

Dist 2

START:	To:	PAGE #
	EVEN PARITY. RCV H	26
E18-3	E16-13 ✓	8/2
E18-6	E29-15 ✓	8/2
E18-10	E29-14 ✓	8/2
E18-13	E29-13 ✓	8/2
E18-2	E16-10, E15-6 ✓	7/2
E16-8	E17-2 ✓	3/2
E14-6	E15-8 ✓	7/2
E29-3	E21-1 ✓	6/2
E17-6	E17-4 ✓	8/2
E29-2	E3-19, E3-1, E4-19, E4-1 ✓	2/2
	RD A/D DATA H	2/2, 3
E21-2	E20-8 ✓	
	RD ADDR L	8/2, 2, 5
E29-1	E31-1, E31-19 ✓	
	RD STATUS L A-35	8/2, 2, 5
E29-4	E33-19, E33-1, E32-19, E32-1 ✓	

A/D ADDR LD
G. 1-6

Dir 4

PAGE # 27

START:	To:	
	UB WR USER REG L	Dir 4
E27-13	E16-2	
E16-3	E27-2, E27-3, E26-11	Dir 4
E27-4	E26-13	Dir 4
E27-10	E28-2	Dir 4
E28-3	E28-11, E25-12	Dir 4
	HEF H	Dir 4, 5
E26-9	E32-11, E63-(1,2,3,4)	
	HEFA H	Dir 4, 5
R39-U	E36-6, E32-13, E27-5	
	HIDR H	Dir 4, 5
R41-U	E32-15, E28-1, E28-13, E25-2, E37-6	
	A/D CY RQ H	Dir 4, 3
E25-13	E24-5	

A/D ADDR LD
E27-1, E24-2

Bit 4

START:	To:	PAGE #
	LAST WD H.	28 Bit 4, 5
E28-9	E33-2 ✓	
	HLWF H	Bit 4, 5
E16-6	E33-4, E64(10, 11, 12, 13) ✓	
	H1A H	Bit 4, 5
E28-5	E32-17, E64-(1, 2, 3, 4) ✓	
C5-BB	R38-BB, E25-7 ✓	Bit 4
C5-CC	E25-6 ✓	
C4-BB	R37-BB, E25-15 ✓	Bit 4
C4-CC	E25-14 ✓	
	LD A/D ADDR H	Bit 4, 3
E27-1	E24-2 ✓	
	A/D DMA EN H	Bit 4, 3
E20-13	E20-9, E25-3, E25-11, E26-1 ✓	

Control

2.1.1

START:	To:	PAGE#
	A/D DTA TO CABLE L	29 Pl. 3, 7
E20-10	E35-19, E35-1, E34-1, E34-19 ✓	
	DATA RDY H	Pl. 3
E22-2	E22-6, E22-11 ✓	
	D/A DATA EN H	Pl. 3
E20-4	E22-1, E23-3 ✓	
E21-6	E22-13, E19-2 ✓	Pl. 5
E20-11	E20-6, E17-8 ✓	Pl. 3
E20-12	E21-4, E24-1 ✓	Pl. 5
	DATA DATA RDY H	
E20-2	E22-9, E63-(10,11,12,13), E32-4 ✓	Pl. 3, 5
	HOA H	
R43-U	E38-6, E21-5, E32-6 ✓	Pl. 3, 5
	DATA EN H	Pl. 3, 5
E17-9	E32-8 ✓	
	LD ADDR H	Pl. 3, 5
E24-4	E62-11 ✓	
	ADDR RDY H	Pl. 3, 5
E22-5	E23-2, E24-3, E32-2 ✓	

START:

TO:

PAGE# 30

R47-U	E40-6, E33-6 ✓	8/15/5
R45-U	E39-6, E33-8 ✓	2/15/5
E19-3	E24-6 ✓ D/A CYC RPT H	8/15/3
C3-BB	R36-BB, E23-15 ✓	2/15/3
C3-CC	E23-14 ✓	
E23-4	E19-1 ✓	8/15/3
E20-1	E17-11	
E16-11	E14-4	
E2-H3	E12-13	
E21-12	E21-11 E21-9	
J1-50	J1-48	
REMOVE	E26-5 to E25-10	
"	E28-8 to E16-4	
"	GND FROM E25-9	
ADD	E26-3 to E25-9	
	E25-10 to VCC	
	E16-4 to E16-5	
	J1-34 to E9-9	
	E9-11 to E19-9	
	D-K2 to D-L2	
	D-M2 to D-N2	
	D-R2 to D-P2	A-39
	D-S2 to D-T2	
	C-A1 to C-B1	

APPENDIX B

SCHMATICS
AND
WIREWRAP LIST

REV	DATE	TIME	DESCRIPTION	APPROVAL

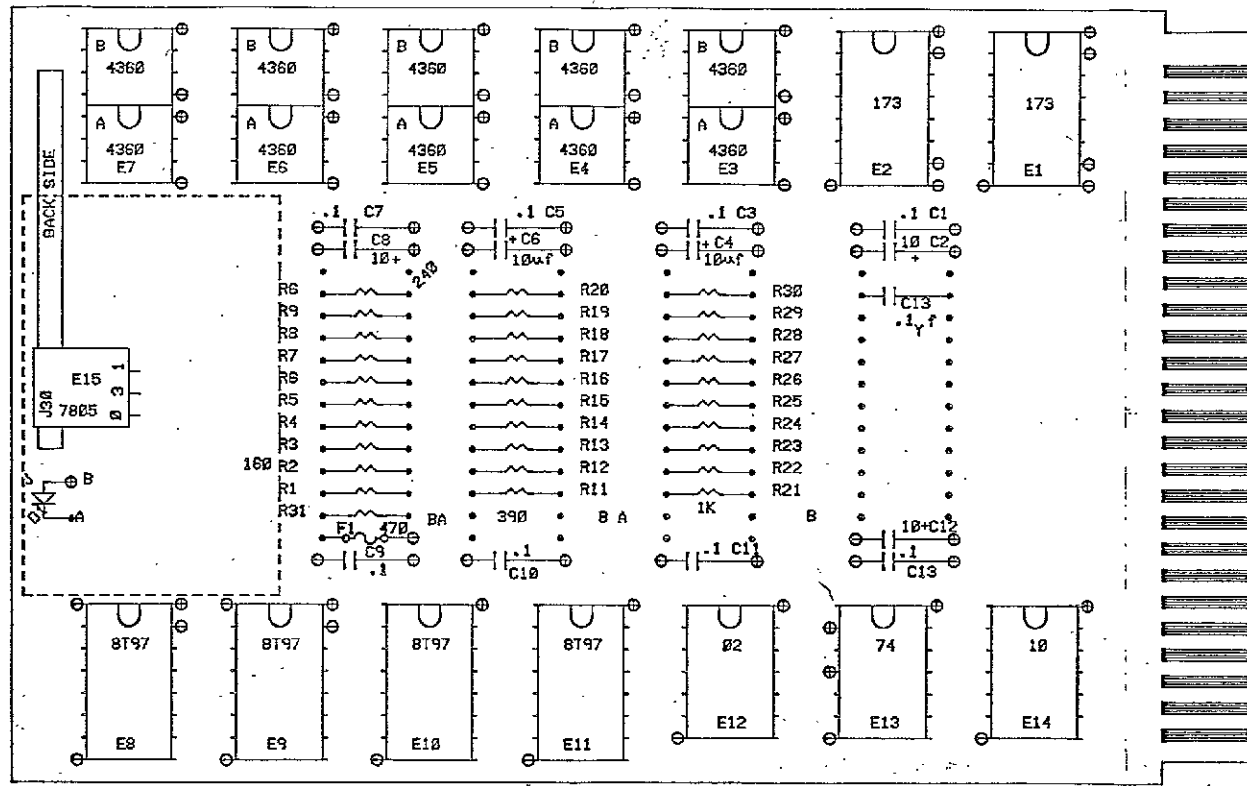

COMPONENT SIDE

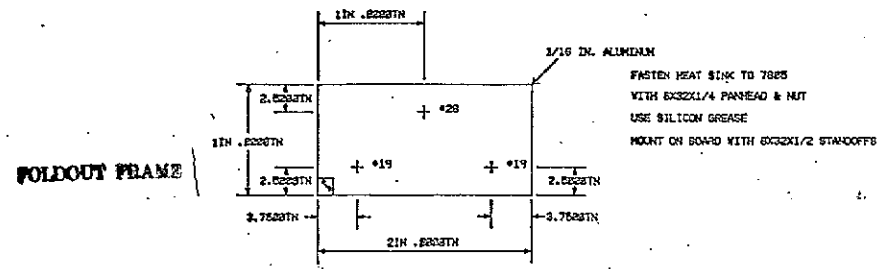

2 FOLDOUT FRAME

M&S COMPUTING, INC. MONTVILLE, ALABAMA		SAES	
ORDINATOR P/NK _____ DATE _____		SAES/MMES INTERFACE	
CHECKED _____ DATE _____		COMPONENT ARRANGEMENT	
APPROVED _____ DATE _____		11/70 DMA/7902 INTERFACE	
MATERIAL: _____ TOLERANCES: _____		PART NO. _____	
DEPARTMENT 2131	DATE DESIGN FILE 791002.DGN	SCALE 1:1	REV B
DRAWN BY 2112-9382	DATE 11/70	SHEET 1 OF 1	

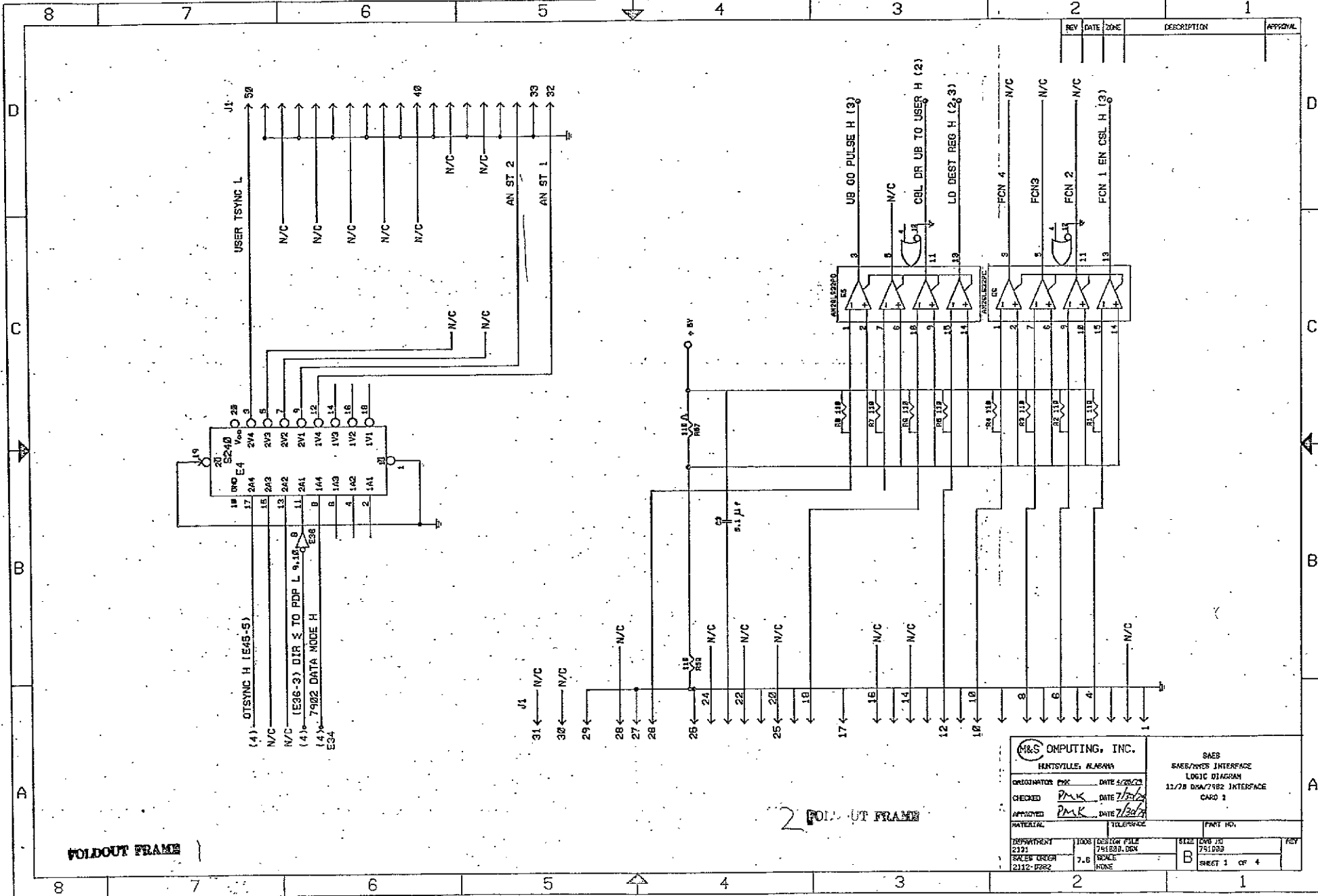

REV	DATE	ZONE	DESCRIPTION	APPROVAL

M&S COMPUTING, INC.
 HUNTSVILLE, ALABAMA

SAES
 SAES/HWS INTERFACE
 LOGIC DIAGRAM
 11/78 DSA/7982 INTERFACE
 CARD 1

ORDINATOR PMK DATE 5/28/82
 CHECKED PMK DATE 7/28/82
 APPROVED PMK DATE 7/28/82

PARTIAL: _____ TELEPHONE: _____ PART NO: _____

DEPARTMENT 2121	1008 DESIGN FILE 79183B.DWG	8182 DWS JSI 751D39	TEST
SALES ORDER 2112-0082	7.6 PRICE NONE	B	SHEET 1 OF 4

FOLDOUT FRAME

2 FOLDOUT FRAME

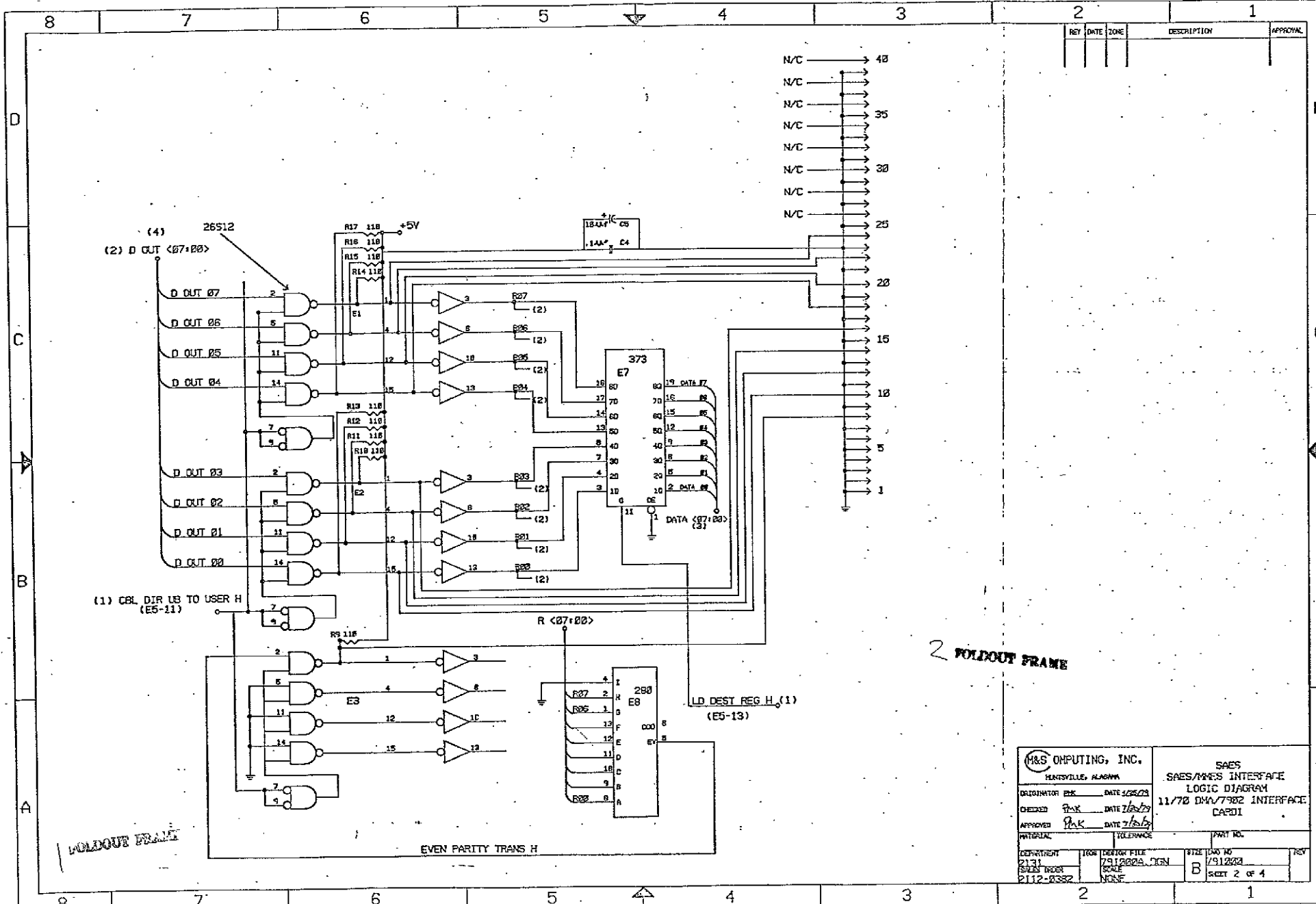

(4) 26512
(2) D OUT <07*00>

(1) CBL DIR US TO USER H
(E5-11)

R <07*00>

LD DEST REG H (1)
(E5-13)

EVEN PARITY TRANS H

2 FOLDOUT FRAME

FOLDOUT FRAME

REV		DATE	ZONE	DESCRIPTION	APPROVAL

M&S COMPUTING, INC. HENSVILLE, ALABAMA		SAES SAES/MMS INTERFACE LOGIC DIAGRAM 11/70 DMA/7982 INTERFACE CARD1			
ORIGINATOR PK CHECKED PK APPROVED PK MATERIAL	DATE 12/29/79 DATE 12/29/79 DATE 12/29/79				
DEPARTMENT 2131 DRAWING NO. 2112-0332	TITLE 751200A.IGN SCALE NGR	SIZE B DATE 9/12/82	SHEET 2 OF 4		

REV	DATE	BY	DESCRIPTION	APPROVAL

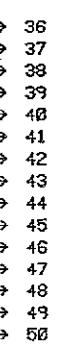
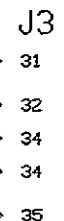
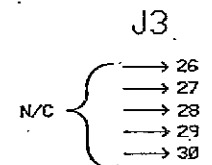
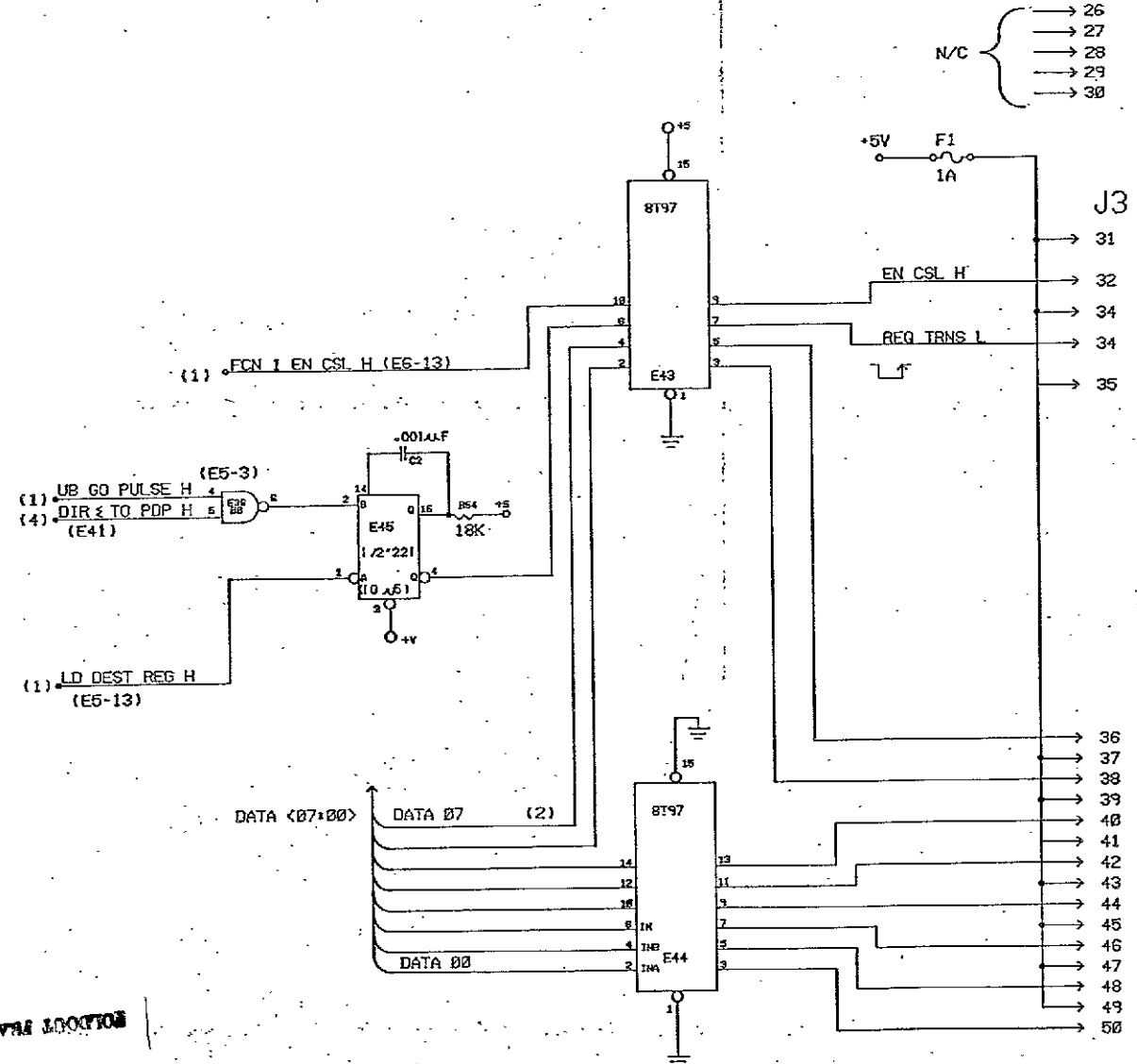

2 FOLDOUT FRAME

FRAME LOCATION

M&S COMPUTING, INC. HUNTSVILLE, ALABAMA		SAES	
ORIGINATOR: ENK		DATE: 4/28/73	
CHECKED: PAK		DATE: 7/30/73	
APPROVED: PAK		DATE: 7/30/73	
PARTIAL		TOLERANCE	
DEPARTMENT: 2131		PART NO.:	
SALES CODE: 2112-0382		731000	
TOOL: NONE		B	
DESIGN FILE: 791000.DGN		SHEET 3 OF 4	
DATE: 7/30/73		REV:	

REV	DATE	ZONE	DESCRIPTION	APPROVAL

J3

FOLDFOUT FRAME

(2)
D OUT <07, 00>

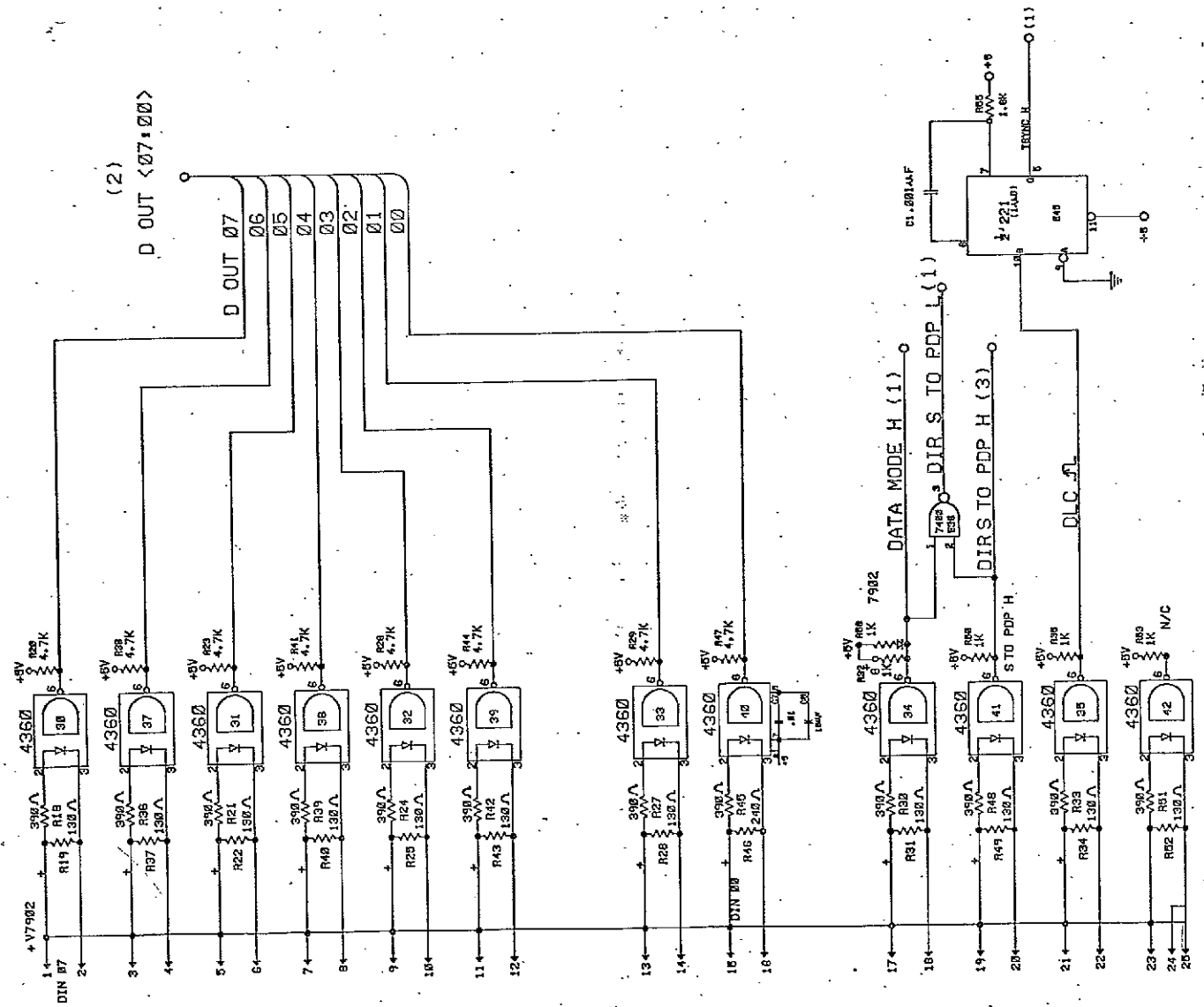

2 FOLDFOUT FRAME

M&S COMPUTING, INC. Huntsville, Alabama		SAES	
DATE 4/28/73		SAES/MHES INTERFACE	
CHECKED <i>Pmk</i> DATE 7/3/73		LOGIC DIAGRAM	
APPROVED <i>Pmk</i> DATE 7/3/73		11/70 DMA/7902 INTERFACE	
MATERIAL TOLERANCE		CARD1	
DESIGNER	DATE	SIZE	PWT NO.
2131	7/3/73	B	791880
2112-8382	NONE	SHEET 4 OF 4	

REV	DATE	BY	DESCRIPTION	APPROVAL

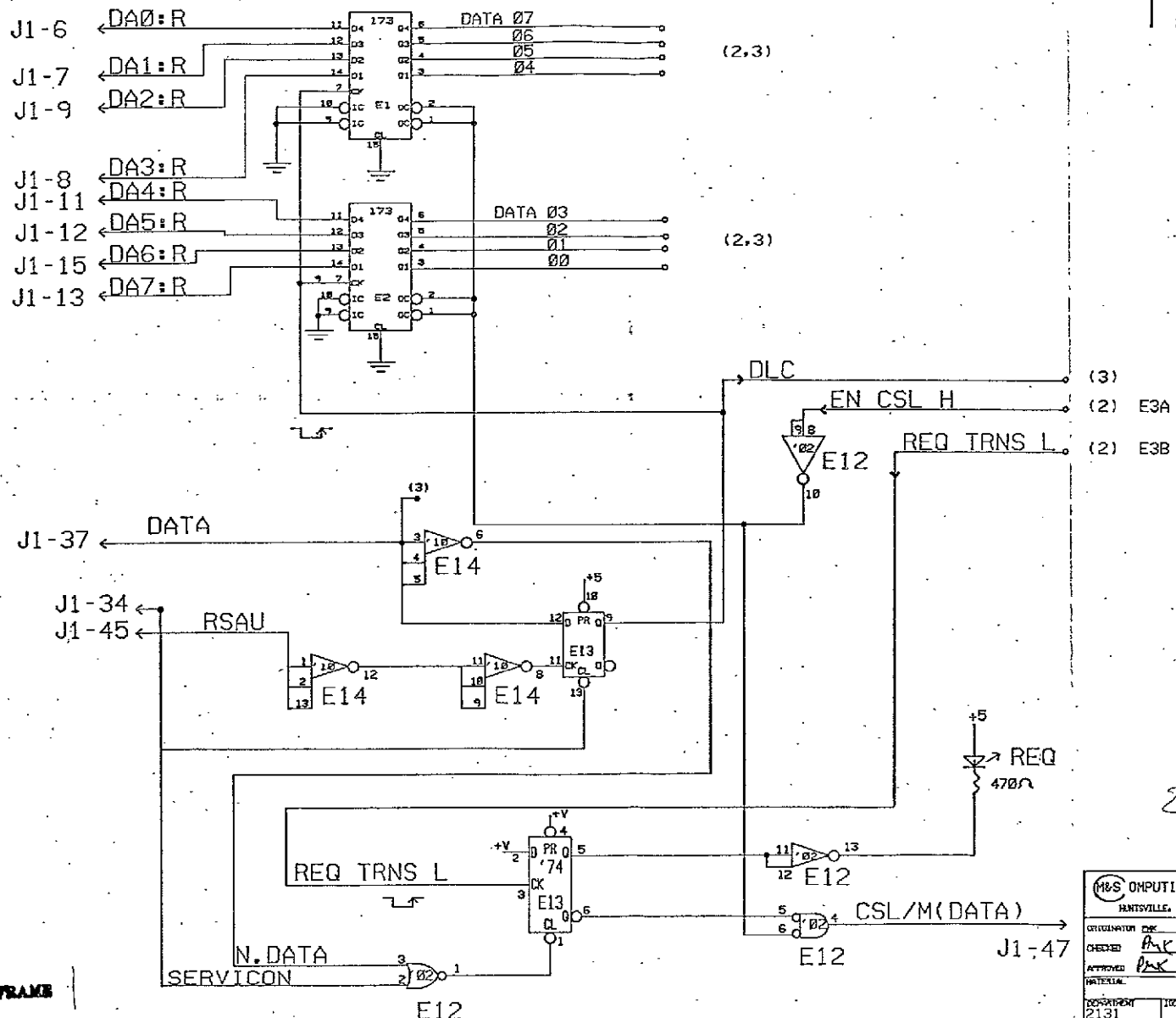

2 FOLDOUT FRAME

FOLDOUT FRAME

M&S COMPUTING, INC. HUNTSVILLE, ALABAMA		SAES SAES/MMES INTERFACE LOGIC DIAGRAM	
ORIGINATOR: <i>DK</i> CHECKED: <i>DK</i> APPROVED: <i>DK</i> MATERIAL:	DATE: <i>1/22/71</i> DATE: <i>2/6/71</i> DATE: <i>2/6/71</i>	11/70 DMA/7902 INTERFACE CARD 2	
DEPARTMENT: 2131 SCALE CODES: 2112-0302	ORDER FILE: 791001.DGN NONE	SIZE: 1005 30 B	REV: 291001 sheet 1 of 3

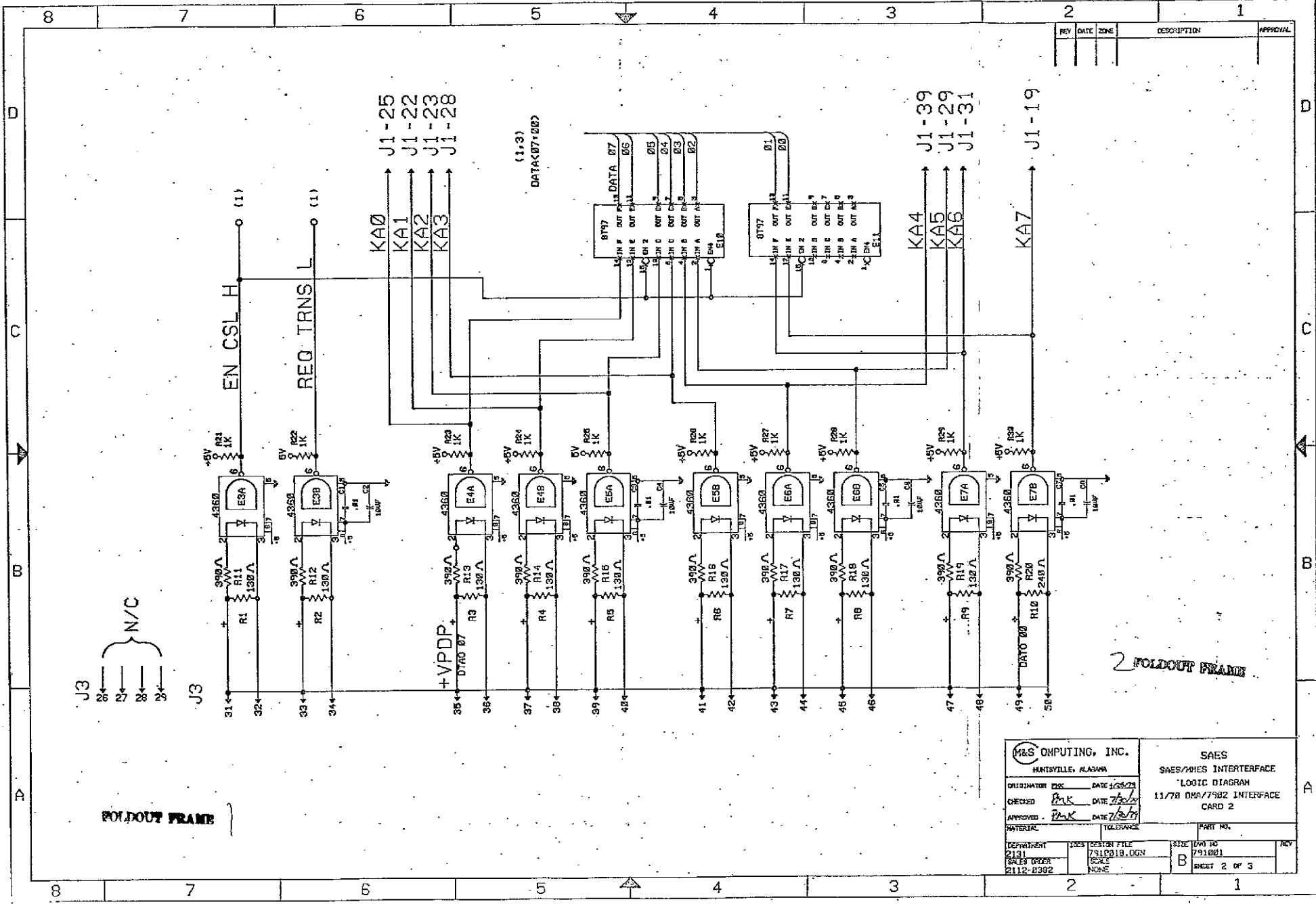

J3
26
27
28
29
N/C

FOLDOUT FRAME

(1,3)
DATA(07,08)

2 FOLDOUT FRAME

M&S COMPUTING, INC. HUNTSVILLE, ALABAMA		SAES SAES/AMES INTERINTERFACE LOGIC DIAGRAM	
ORIGINATOR: <i>PK</i>	DATE: <i>1/28/78</i>	11/78 DMA/7982 INTERFACE CARD 2	
CHECKED: <i>PK</i>	DATE: <i>7/2/77</i>		
APPROVED: <i>PK</i>	DATE: <i>7/2/77</i>		
MATERIAL:	TOLERANCE:	PART NO.:	
DEPARTMENT: 2131	DRAWING FILE: 7910018.DGN	SIZE: 0.00 TO 0.01	REV: 791001
SALES ORDER: 2112-0392	SCALE: NONE	B	SHEET 2 OF 3

REV	DATE	ZONE	DESCRIPTION	APPROVAL

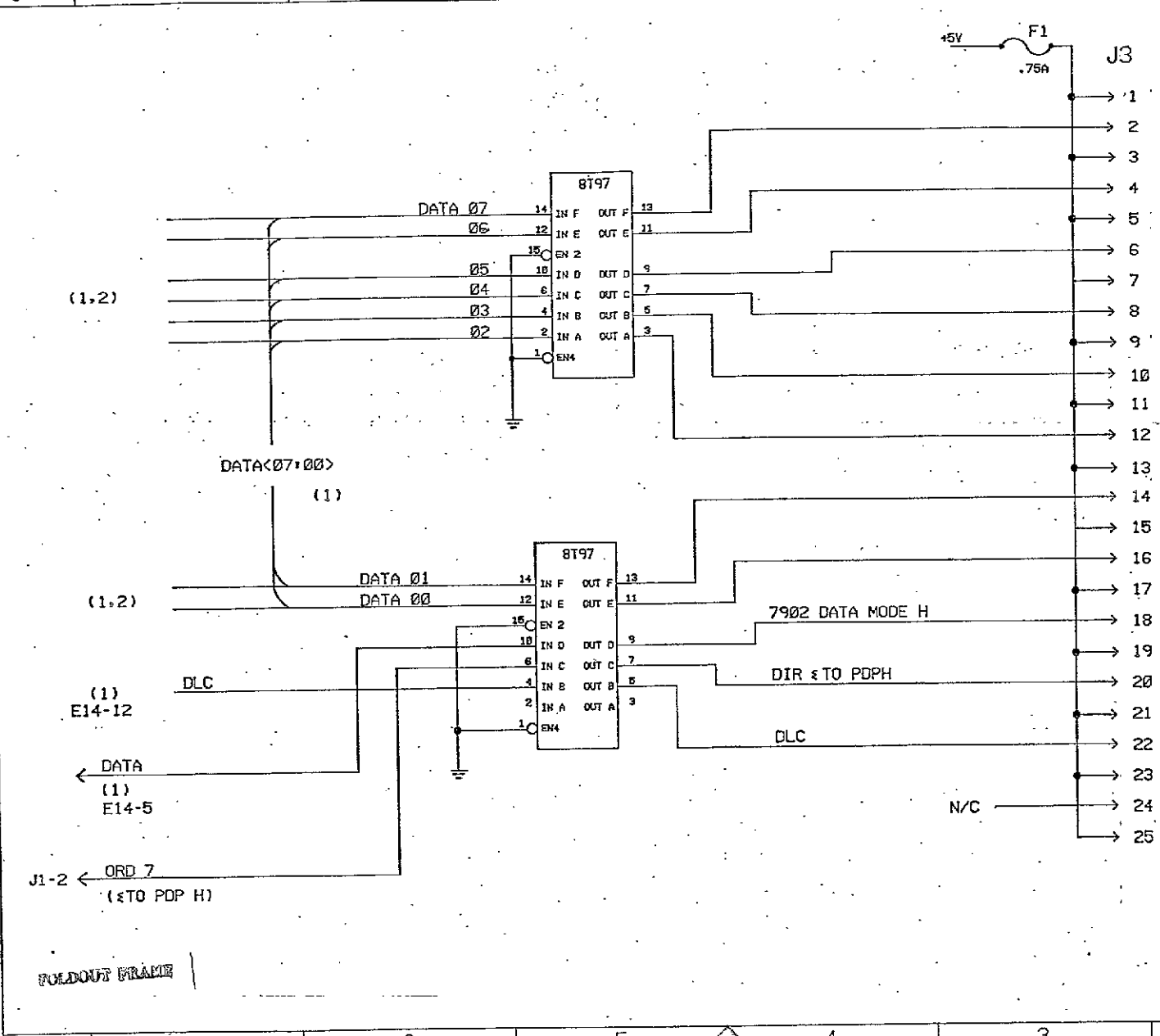

2 FOLDOUT FRAME

M&S COMPUTING, INC. MONTICELLO, ALABAMA		SAES SAES/MMES INTERFACE LOGIC DIAGRAM	
COORDINATOR	DATE	11/78	DHA/7902 INTERFACE
CHECKED	DATE	11/78	CARD 2
APPROVED	DATE	11/78	
PARTIAL	TOLERANCE	PART NO.	
DEPARTMENT	1008 DESIG FILE	SIZE	NO
2131	791001A.DGN	B	791001
SALES ORDER	SERIAL	sheet 3 of 3	
2112-0382	NONE		

SAES
SAES/MMES INTERFACE
WIREWAP LAYOUT LIST

CARD 1

Reference Drawing
Logic Diagram 791000

B-10

PRECEDING PAGE BLANK NOT FILMED

START:

To:

PAGE # 5

GROUND BUSS

J₂ (ODD) , J₁ (ODD)

E1-8, LL-14, E2-8, E3-14, E3-11, E3-5, E3-8, LL-34

E4-1, E4-19, E4-10, E5-12, E5-9, LL-56, E6-12, E6-8

E7-1, E7-10, JJ-31, E8-4, E8-7, JJ-44, JJ-49, JJ-54, JJ-59

E30-5, K-8, E31-5, K-21, E32-5, E33-5, K-39, E34-5, E35-5, K-56

E37-5, H-12, E38-5, E39-5, H-30, E40-5, E41-5, H-48, E42-5

E43-1, E43-8, E-43, E44-1, E44-15, E44-8, E45-8, E45-9

START:

To:

PAGE #6

+5 BUSS

E1-16, MM-14, E2-16, E3-16, MM-34, E4-20, E5-16, E5-4

MM-56, E6-16, E6-4

KK-4, KK-7, E7-20, KK-31, E8-14, KK-40, (KK-42 → KK-63)

M-2

E30-8, L-8, L-9, E31-8, L-18, L-21, E32-8, L-27, E33-8

L-36, L-39, E34-8, L-45, E35-8, L-54, L-56, E36-14

E37-8, J-9, J-12, E38-8, J-18, E39-8, J-27, J-30, E40-8

J-36, E41-8, J-45, J-48, E42-8, J-54, J-58, J-60, J-64

E43-16, E43-15, F-43, E44-16, E45-16, E45-3, E45-11

J3

SHEET 4

11/34 / SIGMA IF
CARD 1

START:

TO:

PAGE # 7

R19-L R18-L, J3-1 ✓

R22-L R21-H, J3-5 ✓

R25-L R24-L, J3-9 ✓

R28-L R27-L, J3-13 ✓

R31-L R30-L, J3-17 ✓

R34-L R33-L, J3-21 ✓

R37-J R36-J, J3-3 ✓

R40-J R39-J, J3-7 ✓

R43-J R42-J, J3-11 ✓

R46-J R45-J, J3-15 ✓

R49-J R48-J, J3-19 ✓

R52-J R51-J, J3-23 ✓

J3-2 R19-K, E30-3 ✓

J3-4 R37-H, E37-3 ✓

J3-6 R22-K, E31-3 ✓

J3-8 R40-H, E38-3 ✓

J3-10 R25-K, E32-3 ✓

J3-12 R43-H, E39-3 ✓

J3-14 R28-K, E33-3 ✓

J3-16 R46-H, E40-3 ✓

J3-18 R31-K, E34-3 ✓

J3-20 R49-H, E41-3 ✓

J3-22 R34-K, E35-3 ✓

J3-24 R52-H, E42-3 ✓

ORIGINAL PAGE IS
OF POOR QUALITY

START: To:

PAGE # 8

J3-1	J3-3, J3-5, J3-7, J3-9, J3-11, J3-13, J3-15, J3-17, J3-19		
	J3-21, J3-23, J3-25, IN RTN	SHEET 4	✓
F1-H	J3-31, J3-33, J3-35, J3-37, J3-39, J3-41, J3-43, J3-45		
	J3-47, J3-49 ✓ out RTN	SHEET 3	

E43-9	J3-32	EN CSL H	✓	
E43-7	J3-34	REQ TRNS L	✓	
E43-5	J3-36	} DATA OUT	✓	
E43-3	J3-38		✓	
E44-13	J3-40		✓	
E44-11	J3-42		SHEET 3	✓
E44-9	J3-44		✓	
E44-7	J3-46		✓	
E44-5	J3-48	✓		
E44-3	J3-50	✓		

START: To:

PAGE # 9

E44-2	E7-2	DATA 95 ✓
E44-4	E7-5	✓
E44-6	E7-6	✓
E44-10	E7-9	✓
E44-12	E7-12	✓
E44-14	E7-15	✓
E43 2	E7-16	✓
E43-4	E7-19	✓

DATA <01.00>

E2-13	E8-8, E7-3	✓
E2-10	E8-9, E7-4	✓
E2-6	E8-10, E7-7	✓
E2-3	E8-11, E7-8	✓ R <07:00>
E1-13	E8-12, E7-13	✓
E1-10	E8-13, E7-14	✓
E1-6	E8-1, E7-17	✓
E1-3	E8-2, E7-18	✓

R20-K	E30-6, E1-2	✓
R38-H	E37-6, E1-5	✓
R23-K	E31-6, E1-11	✓
R41-H	E38-6, E1-14	✓ D: - <01.00>
R26-K	E32-6, E2-2	✓
R44-H	E39-6, E2-5	✓
R29-K	E33-6, E2-11	✓ B-19
R47-H	E40-6, E2-14	✓

START: To:

PAGE# 10

R58-N	D1-M ✓	
D1-N	E34-6, R32-K, E36-1, E4-8 ✓	DATA MODE H
E41-6	R50-H, E36-5, E36-2 ✓	DIRE TO PDP H
E35-6	R35-K, E45-10 ✓	NDLC
C1-H	E45-6 ✓	
R55-H	C1-J, E45-7 ✓	
E45-5	E4-17 ✓	T SYNC H
E36-3	E36-9, E36-10 } ✓	DIRE TO PDP L H
E36-8	E4-11 }	
E6-13	E43-10 ✓	FCW I ENCSL H
E5-3	E36-4 ✓	UB GO PULSE H
E45-1	E5-13, E7-11 ✓	LD DEST REG H
E1-7	E1-9, E2-7, E2-9, E3-7, E3-9, E5-11 ✓	CBL DIR WB TO USER H

J1 WIRING

START:

TO:

PAGE # 12

R56-JJ	C3-JJ, J1-25 (BURAPS) ✓
R57-JJ	R56-KK, ES-2, ES-6, ES-9, ES-14, EG-2, EG-6, EG-10, EG-14 ✓
R1-JJ	EG-15, J1-4 ✓
R2-JJ	EG-9, J1-6 ✓
R3-JJ	EG-7, J1-8 ✓
R4-JJ	EG-1, J1-10 ✓
R5-JJ	ES-15, J1-12 ✓
R6-JJ	ES-10, J1-18 ✓
R7-JJ	ES-7 ✓
R8-JJ	ES-1, J1-26 ✓
E4-2	J1-32
E4-9	J1-34 ✓
E4-3	J1-50 ✓

CONTINUITY COMPLETION

CARD	EDGE CONNECTOR	PINS
D-L2	D-L2	✓ B67
D-M2	D-N2	✓ B66
D-P2	D-R2	✓ B65
D-S2	D-T2	✓ B64
C-A1	C-B1	✓ NPG

START: To:

PAGE# 13

R36-H E37-2

R39-H E38-2

R42-H E39-2

R45-H E40-2

R48-H E41-2

R51-H E42-2

R18-K E30-2

R21-K E31-2

R24-K E32-2

R27-K E33-2

R30-K E34-2

R33-K E35-2

E36-G E45-2

ORIGINAL PAGE IS
OF POOR QUALITY

SAES
SAES/MMES INTERFACE
WIREWRAP LIST

CARD 2

START: To:

PAGE # 2

J1-2	E1-15, E1-10, E1-9, E1-8, C1-A, C2-A, E2-15, E2-10, E2-9	GROUND
	E2-8, C3-A, C4-A, E3A-5, E3B-5, E4A-5, E4B-5	
	C5-A, C6-A, E5A-5, E5B-5, E6A-5, E6B-5	
	C7-A, C8-A, E7A-5, E7B-5, E15-3, E8-1, E8-8, E9-8, E8-15, E9-1,	
	C9-A, E9-15, E10-8, E11-8, C10-A, E12-7, E13-7, C11-A, E14-7,	
	C13-A, C12-A	
J1-51	E15-1	+8V
E15-2	D1-B, E8-16, E9-16, C9-B, F1-B, E10-16, E11-16, C10-B, E12-14,	+5V
	E13-2, E13-4, C11-B, E13-14, E14-14, C13-B, C12-B, E13-10	
E15-2	E7A-8, E7B-8, E6B-8, E6A-8, C7-B, C8-B, E5A-8, E5B-8,	
	E4B-8, E4A-8, C3-B, C4-B, E3A-8, E3B-8, E2-16, E1-16,	
	C1-B, C2-B	
F1-A	J3 - {1, 3, 5, 7, 9, 11, 13, 15, 17, 19, 21, 23, 25}	

START: To:

PAGE # 3

J1-6	E1-11		DA0:R
J1-7	E1-12		DA1:R
J1-9	E1-13		DA2:R
J1-8	E1-14		DA3:R
J1-11	E2-11		DA4:R
J1-12	E2-12		DA5:R
J1-15	E2-13		DA6:R
J1-13	E2-14		DA7:R
J1-37	E14-3, E14-4, E14-5, E9-10, E13-12		DATA
J1-34	E13-13, E12-2		SERVICON
J1-45	E14-2, E14-1, E14-13		RSAU
E14-6	E12-3		NDA
E12-1	E13-1		DATA+SERVICON
E13-8	E12-5		NREQ
E12-10	E12-6, E2-1, E2-2, E1-1, E1-2		EN CSLL
E14-12	E14-11, E14-10, E14-9		NRSAU
E3B-6	E13-3		REQ TRANS L
E1-6	E10-13, E8-14		DATA Q7
E1-5	E10-11, E8-12		DATA Q6
E1-4	E10-9, E8-10		DATA Q5
E1-3	E10-7, E8-6		DATA Q4
E2-6	E10-5, E8-4		DATA Q3
E2-5	E10-3, E8-2		DATA Q2
E2-4	E11-13, E9-14		DATA Q1
E2-3	E11-11, E9-12	B-27	DATA Q0
E14-8	E13-11		RSAAU
E2-7	E1-7, E13-9, E9-4		DLC

START:

TO:

PAGE # 5

J3-31	J3-33, J3-35, J3-37, J3-39, J3-41, J3-43, J3-45, J3-47, J3-49 ✓
J3-31	R1-B, R11-A ✓
J3-33	R2-B, R2-A ✓
J3-35	R3-B, R3-A ✓
J3-37	R4-B, R4-A ✓
J3-39	R5-B, R5-A ✓
J3-41	R6-B, R6-A ✓
J3-43	R7-B, R7-A ✓
J3-45	R8-B, R8-A ✓
J3-47	R9-B, R9-A ✓
J3-49	R10-B, R20-A
J3-32	R1-A, E3A-3 ✓
J3-34	R2-A, E3B-3 ✓
J3-36	R3-A, E4A-3 ✓
J3-38	R4-A, E4B-3 ✓
J3-40	R5-A, E5A-3 ✓
J3-42	R6-A, E5B-3 ✓
J3-44	R7-A, E6A-3 ✓
J3-46	R8-A, E6B-3 ✓
J3-48	R9-A, E7A-3 ✓
J3-50	R10-A, E7B-3 ✓

START:

TO:

PAGE # 6

R11-B	E3A-2 ✓
R12-B	E3B-2 ✓
R13-B	E4A-2 ✓
R14-B	E4B-2 ✓
R15-B	E5A-2 ✓
R16-B	E5B-2 ✓
R17-B	E6A-2 ✓
R18-B	E6B-2 ✓
R19-B	E7A-2 ✓
R20-B	E7B-2 ✓

L12-B	R21-B, R22-B, R23-B, R24-B, R25-B, R26-B, R27-B, R28-B, R29-B, R30-B
-------	--

R21-A	E3A-6 ✓
R22-A	E3B-6 ✓
R23-A	E4A-6 ✓
R24-A	E4B-6 ✓
R25-A	E5A-6 ✓
R26-A	E5B-6 ✓
R27-A	E6A-6 ✓
R28-A	E6B-6 ✓
R29-A	E7A-6 ✓
R30-A	E7B-6 ✓

SIGNAL	IF PLAN	DL7902
DA0:R	6	24-5
DA1:R	7	24-8
DA2:R	9	24-23
DA3:R	8	24-29
DA4:R	11	24-41
DA5:R	12	24-17
DA6:R	15	24-26
DA7:R	13	24-44
DATA	37	22-35
SERV:CON	34	23-38
RSAU	45	28-06
PHTO	21	29-11
CSL/M(DATA)	47	23-37
KA0	25	21-47
KA1	22	21-24
KA2	23	21-43
KA3	28	21-36
KA4	39	21-21
KA5	29	21-02
KA6	31	21-12
KA7	19	21-11
ORD 7	2	21-9

MUOP MODS TO 7902 + IF

APPENDIX C

UDIF REPLACEMENT

The UDIF boards used in the SAES Engine Dynamics Simulator for the EDS/ESS and the EDS/MMES interfaces differ in two ways:

1. The vector interrupt address for the ESS interface is 0260 while the MMES interface uses address 0264 as an interrupt vector.
2. The UDIF register addresses for the ESS interface begin at octal address 17764000 while the MMES interface UDIF register addresses begin at octal address 17764040.

The vector interrupt address for the ESS interface is obtained by setting positions 2, 4, and 5 of the dip switch on board 2 to the on state (away from the side marked open).

The vector interrupt address for the MMES interface is obtained by setting positions 2, 4, 5, and 7 to the on state.

The starting address for the UDIF registers is set with jumpers at the lower left-hand corner of board 1. For the ESS interface, jumper number 8 is connected to G. For the MMES interface, jumpers number 8 and 5 are connected to G.