



Ergonomics evaluation into the safety of stepladders

Literature and standards review
Phase 1

Prepared by
Loughborough University
for the Health and Safety Executive

CONTRACT RESEARCH REPORT
418/2002



Ergonomics evaluation into the safety of stepladders

Literature and standards review Phase 1

**Tanya Navarro BA BSc MSc
Laurence Clift MSc**

**Research Institute for Consumer Ergonomics
Loughborough University
Holywell Building, Holywell Way
Loughborough
Leicestershire LE11 3TU
United Kingdom**

This report serves to summarise the current state of publications, literature, Standards and Regulations affecting the safety of stepladders, particularly where intended for, or used in, the UK market. It reviews the current state of knowledge on ladder design, user expectation, risk perception and accident epidemiology. It further contains a review and comparison of the applicable laws and technical standards which cover products sold and used in the UK, where appropriate exploring the relationship between these publications and those available in other countries. This work is intended to establish the knowledge base necessary to justify, design and execute a range of dynamic testing intended to examine in more depth the factors affecting the stability of stepladders.

This report and the work it describes were funded by the Health and Safety Executive. Its contents, including any opinions and/or conclusions expressed, are those of the authors and do not necessarily reflect HSE policy.

© Crown copyright 2002

Applications for reproduction should be made in writing to:
Copyright Unit, Her Majesty's Stationery Office,
St Clements House, 2-16 Colegate, Norwich NR3 1BQ

First published 2002

ISBN 0 7176 2302 5

All rights reserved. No part of this publication may be reproduced, stored in a retrieval system, or transmitted in any form or by any means (electronic, mechanical, photocopying, recording or otherwise) without the prior written permission of the copyright owner.

Contents

1.0 Background and scope of the study.....	1
2.0 Investigation into stepladder accidents.....	5
2.1 Accidents in the workplace	5
2.2 Other data on ladder accidents	12
2.3 Stepladder accidents in a domestic setting.....	14
2.4 European data.....	17
2.5 Causes of stepladder accidents.....	19
2.6 Stability testing	22
2.7 Overall Conclusions	27
3.0 Ladders	29
3.1 Types.....	29
3.2 Ownership	30
3.3 Effects of stepladder rung shape, spacing and angle.....	30
3.4 Ladder usage	33
3.5 Conclusions.....	39
4.0 Instructions and warnings.....	40
4.1 Guidelines and standards on warnings and the safe use of products.....	40
4.2 Why warnings fail.....	41
4.3 Development of effective warnings	44
4.4 Labelling on ladders.....	45
5.0 Comparison of European, National and International Standards ..	47
5.1 A review of BS EN 131 : Ladders	48
5.2 A review of BS 2037 : 1994.....	57
5.3 Comparison of EN 131 : 1993 and BS 2037 : 1994.....	65
5.4 Comparison of EN 131 with other national standards	66
5.5 Conclusion	67
6.0 Regulations Applicable to Ladders	68
6.1 Provision and Use of Work Equipment Regulations 1998 (PUWER 98).....	68
6.2 The Management of Health and Safety at Work Regulation 1999	69
6.3 The Workplace (Health, Safety and Welfare) Regulations (WHSW) 1992.....	69

6.4	A Guide to the Construction (Health, Safety and Welfare) Regulations (CHSW) 1996	70
6.5	ANNEX: AMENDING PROPOSAL OF DIRECTIVE 89/655/EEC CONCERNING THE MINIMUM SAFETY AND HEALTH REQUIREMENTS FOR THE USE OF WORK EQUIPMENT BY WORKERS AT WORK (SECOND INDIVIDUAL DIRECTIVE WITHIN THE MEANING OF ARTICLE 16 OF DIRECTIVE 89/391/EEC) Version 4.4.....	71
6.6	Conclusion and recommendations	75
7.0 Conformity with European Union Requirements		77
8.0 Product review.....		79
8.1	Selection criteria and purchase of ladders.....	79
8.2	List of organisations and individuals contacted	82
9.0 References		83
10.0 Standards and Regulations		87
11.0 Glossary.....		89
 APPENDICES		
Appendix: 1	Table of Standards Comparison.....	91
Appendix: 2	Ladder Products Reviewed.....	101
Appendix: 3	Example Letter – Agencies.....	107
Appendix: 4	Example Letter – Manufacturers.....	111
Appendix: 5	Example Letter – Hire Shops.....	115
Appendix: 6	Example Letter – Consumers Associations.....	119
Appendix: 7	People, Organisations and Agencies Contacted.....	123

Table of Figures

Figure 1	6
Figure 2	8
Figure 3	8
Figure 4	9
Figure 5	9
Figure 6	11
Figure 7	11
Figure 8	12
Figure 9	50
Figure 10	53
Figure 11	53
Figure 12	54
Figure 13 & Figure 14	55
Figure 15	55
Figure 16	59
Figure 17	61
Figure 18	63
Figure 19	64

Executive Summary

This review appraises relevant published documents to determine the current understanding of the issues affecting the stability of stepladders. In doing so it identifies that, whilst there have been many attempts to conduct research into this issue, these have only ever been partly successful. Most research appears to only address certain aspects of the safety provided, instead of approaching the problem holistically. As such, actions following any research undertaken have been small-scale, largely unmonitored and arguably ineffective.

A further appraisal of the human factors issues relating to stepladder use reveals it to be a complex area, involving not just simple mechanical actions, but also risk perception, behaviour modifications and the effectiveness of warnings and labelling. Again, whilst some considerable effort has been made in examining the manifestations of these variables, there is little solid evidence for an understanding of the causes and effects that can fundamentally alter the safety of the stepladder in use.

A review of the accident statistics reveals that stepladders are certainly a highly injurious product. Despite this, the manufacture and use of these products appears less well controlled than other equipment and devices such as power tools or personal protective equipment. However, it is quite clear that intervention in this area could be highly effective in both the prevention of personal suffering and also the saving of costs.

The last section of this report deals with a comparison of the current standards and regulations controlling the manufacture and use of stepladders. It can be seen that whilst considerable effort is being made to ensure that a technically capable product is being manufactured, and professional use is well controlled, these steps do not appear to be effective in reducing the number or severity of accidents in the real world. It is patent that an element is missing in the safety equation, and the conclusion of this report is that only through a better understanding of the users' needs and behaviour can this can be identified. Accordingly, a proposal is made to undertake extensive dynamic trials involving stepladders to evaluate the key variables controlling their stability in use.

See also *Ergonomics evaluation into the safety of stepladders - User profile and dynamic testing: Phase 2* CRR423/2002 HSE Books 2002 ISBN 0 7176 2315 7

1.0 BACKGROUND AND SCOPE OF THE STUDY

This review aims to build upon the knowledge and test methods used in the DTI report (DTI, 1996), in order to examine the behaviour and characteristics of stepladder users, as well as to assess the stability of the stepladders they commonly use. If appropriate the review will, in conjunction with comprehensive dynamic testing, contribute to the proposal of draft requirements for a performance-based test to quantify and help to improve the stability of stepladders. Throughout the document, references to 'ladders' are used only where the source data has not identified type of ladder. All other references are type-specific.

Ladders have been an enduring consumer safety concern, with significant numbers of deaths, hospitalisations and serious injuries attributable to their use. In accident statistics, stepladders are commonly amongst some of the most injurious products within both the domestic and industrial environments and this leads to considerable human suffering and financial cost. This is more surprising given the other objects accounting for injuries, such as grinders, power saws, etc. and activities undertaken, such as vehicle maintenance. The fact that such patently dangerous tools and activities are responsible for lower accident rates than domestic stepladder use suggests that there is a fundamental problem associated with both the design and application of stepladders to tasks.

In the face of this high accident rate, considerable efforts have been made by government bodies and independent research groups to understand the nature of stepladder use and to offer remedial measures for the safety issues identified. The efforts have not been restricted to the UK or Europe, but are seen in virtually all industrialised countries.

Curiously, stepladders are perceived by the majority of users as hazardous products, primarily because of their insubstantial structure and the feelings of insecurity that they generate. Whilst this modifies user behaviour to some degree, it does not, in itself, seem to be a sufficiently strong message to prevent accidents occurring. This would appear, therefore, to contradict the popular belief of risk compensation unless there is another, as yet concealed, factor involved. It has been suggested that this factor may involve mechanical failure of stepladder systems, either through inappropriate use or poor design and manufacture, leading to user injuries. This would appear to be at least partially substantiated by the number of stepladder accidents reported to Trading Standards Officers and Health and Safety Agencies alleging that the stepladder failed whilst in normal use. If such failures were occurring without user misuse, the design of stepladders currently available to the public must be brought into question.

In the majority of such cases, users allege that they were not misusing the stepladder in any way. Such widespread conviction further suggests that either the stepladders involved are faulty in some way or that the user's perception of reasonable use does not match that of the manufacturers. Unfortunately, it is often difficult after an accident to establish whether damage appearing on the stepladder was inflicted during the event by other agents, or occurred spontaneously and initiated the accident. Because of this difficulty, few criminal or civil actions are pursued and, and hence the suitability of current stepladder designs is not challenged.

Stepladder manufacture is largely controlled through the application of voluntary British and European Standards. However, the UK differs somewhat from other European countries in offering a Standard specific to stepladders intended for domestic use (BS 2037 : 1994). The European Standard (BS EN131 : 1993) does not discriminate between 'domestic' and 'light trades' use. This discrepancy is the subject of considerable debate, and has caused some problems where a UK product is supplied to other European countries.

Of greater importance, however, is the apparent difference between the user's expectations and the safety limits that the stepladder provides. Most stepladders bear considerable amounts of user advice, which often seems to contradict the very purpose for which stepladders are intended. Messages such as 'Do not use a stepladder to access high places' or 'Do not stand on the top platform of the stepladder' may have little impact on users who believe that such actions are clearly within the normal function of stepladders.

The continuing trends in accident statistics suggest that user demands, especially for stability, are not being met. Previous research has shown that users do not follow instructions on the use of stepladders, but prefer to trust systems which they self-determine as safe. If this is normal user behaviour, then it must be considered as reasonable, and manufacturers must accommodate it in their designs. Accordingly, there is a need for a suitable test specification which manufacturers, and others, can use to demonstrate that adequate stability is being provided.

Whilst considerable efforts have been made to evaluate the performance of stepladder systems, few studies have approached the problem from the user's perspective. Structural strength and other parameters are quantified on the basis of pre-defined tasks, apparently without foundation on real-world use. Similarly, current standards do not contain a dynamic testing element. Static deformation is clearly an essential part of an effective testing regime, but may not be sufficient on its own to ensure adequate safety in a product which may be in use for many years and which may have a finite fatigue life.

This research intends to establish whether dynamic testing of stepladders is an essential requirement of an effective Standards program. More importantly, it will evaluate whether such testing should accurately reflect the normal behaviour of users, and the reasonable demands they will make on stepladder systems. By adequately measuring, understanding and defining these demands it should be possible to specify a simple and reliable test which will ensure that the user is offered adequate levels of safety. Once this has been established, the benefits of user education and other remedial measures can also be maximised.

This research is the first Phase of this project and establishes the current state of knowledge regarding the stability of stepladders. It also compares and contrasts the various standards and regulations affecting their safety, and identifies any gaps in the knowledge which must be filled prior to undertaking effective dynamic testing.

2.0 INVESTIGATION INTO STEPLADDER ACCIDENTS

2.1 ACCIDENTS IN THE WORKPLACE

2.1.1 MARCODE¹

The Health and Safety Laboratory (HSL, 2000) carried out an investigation into accidents involving all types of ladders. They analysed MARCODE accident data, with particular emphasis on causation. The data was analysed for the years 1990 to 1995, inclusive. The data showed a steady increase in numbers until 1993, after which time the numbers of accidents declined. The severity of the accidents has remained constant. The majority of accidents (56%) resulted in major injuries, although this figure is partially explained by the nature of the sample; HSE-investigated accidents tend to be more serious. The study found the peak age profile of people injured in stepladder accidents to be between 36 and 55. However, in their study, the age of 14% of the individuals was unknown. The victims of the accidents were either employed or self-employed. There were very few trainees involved. The industries that showed the highest incidence of stepladder accidents were construction, manufacturing, agriculture and the service industries.

2.1.2 Reporting of Injuries, Diseases and Dangerous Occurrences Regulations 1995 (RIDDOR) data

Employers, those in control of work premises and self-employed people are required under RIDDOR to report some work-related accidents, diseases and dangerous occurrences. This is a legal requirement and enables the Health and Safety Executive and local authorities to identify where and how risks arise, and to investigate serious accidents. Incidences of the following must be reported:

- A death or major injury.
- An over-three-day injury (an employee or self-employed person is unable to work for over three days after suffering accident at work, but does not have a major injury).
- A work-related disease.
- Dangerous occurrence (something happens that does not result in a reportable injury, but which easily could have).

RIDDOR data on incidence and occupational groups associated with falls from a height involving ladders (all types of ladder) was obtained for the five main industrial sectors, known to have the highest incidence of ladder accidents:

¹ MARCODE is the Database of Investigated Accidents (originally Marches Code)

- Agriculture.
- Construction.
- Manufacturing.
- Service industries.
- Energy.

The data refers to injuries reported to the following bodies:

- Food Operations Directive (FOD).
- Chemical and Hazardous Installations Directive (CHID).
- Nuclear Safety Directive (NSD).
- Local Authorities (LA).

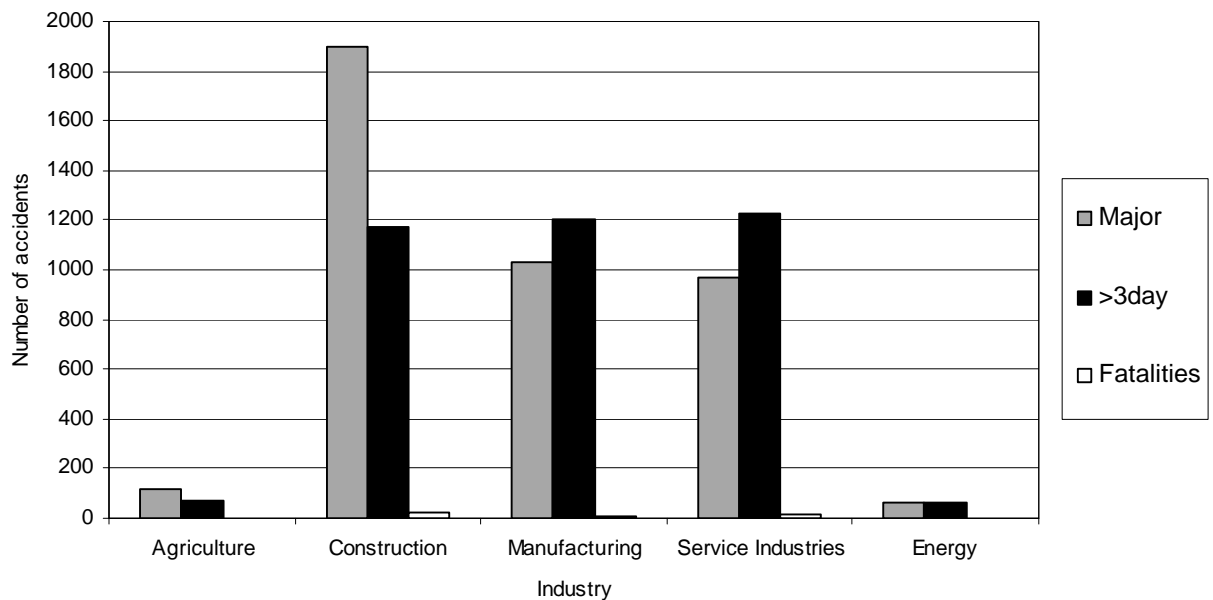

Figure 1
A comparison of the numbers of injuries resulting from ladder-related falls in the major industrial sectors

Figure 1 shows the large differences in the numbers of accidents occurring between the industrial sectors. As can be seen, injuries resulting from falls related to ladder use are most common in the construction industry, which has a much higher number of major injuries and fatalities than the other industries. The numbers include all registered injuries, whether they are inflicted upon employed, self-employed, trainees, or members of the public. A major injury is regarded as a serious injury, and an ‘over three day injury’ refers to a slight injury, but nevertheless one that has lasted for more than three days. If this lasts over three days, the employee is required to provide a self-certificate in order that they may be registered as ‘sick’.

Table 1 shows the numbers of non-employees (self-employed, members of public, trainees, work experience) involved in falls associated with ladders in the industrial sectors. Construction still shows the highest numbers of injuries sustained, with the percentage of non-employed injured being 12%. Of these, 10% were trainees or individuals on work experience, which could suggest that a lack of knowledge or experience is a contributory factor to ladder falls injuries. Similarly, agriculture shows a figure of 11% injured from ladder falls.

Table 1
Numbers of major and >3 day ladder accidents sustained by non-employees of the main industrial sectors

Industry	Serious Accidents	Total number of accidents
Agriculture	21 (11%)	191
Construction	358(12%)	3094
Manufacturing	66 (3%)	2243
Service industries	106 (5%)	2210
Energy	4 (3%)	130

Both agriculture and construction industries tend to employ fairly large numbers of semi-skilled, transient workers, which leads to a large proportion of the workforce being self-employed. This employment status may mean that their level of training is less tightly monitored, which may account for the high numbers of accidents.

2.1.3 Ladder Accidents Across the Industrial Sectors

Figures 2 to 5 show a comparative analysis of the types of ladder accidents, which occurred across the five selected industrial sectors between 1997 and 2000. Figure 2 (Agriculture) demonstrates a reduction in numbers of serious or ‘major injuries’ over the three years, whereas the number of slight or ‘over three day injuries’ remains constant. However, ‘major injuries’ predominate. This trend can also be seen in the construction industry in Figure 3.

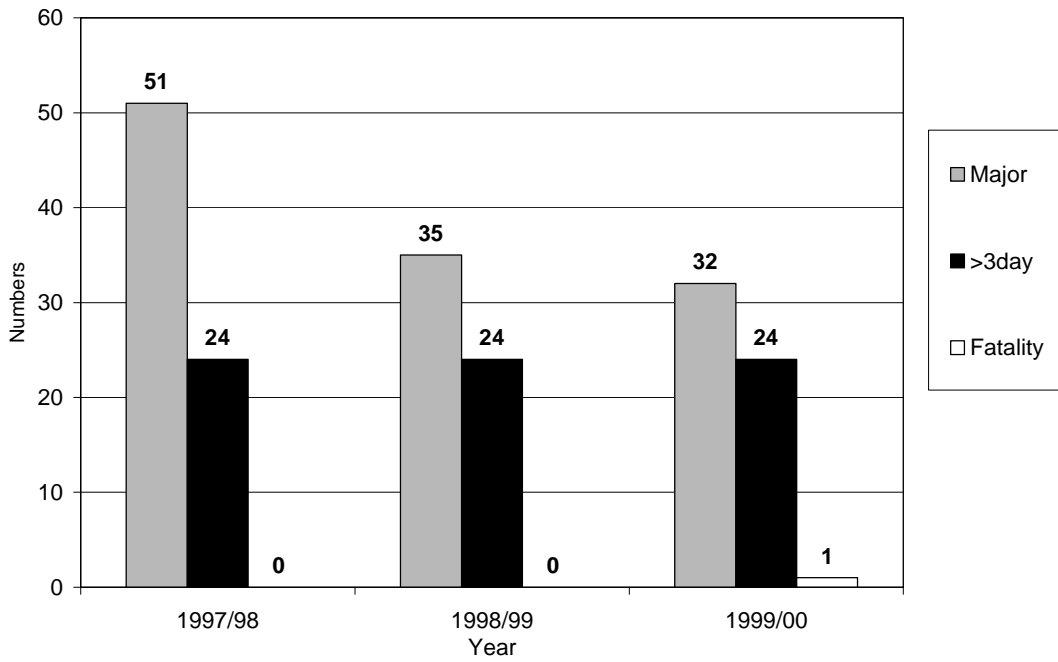

Figure 2
Reported ladder accidents in the agricultural industry

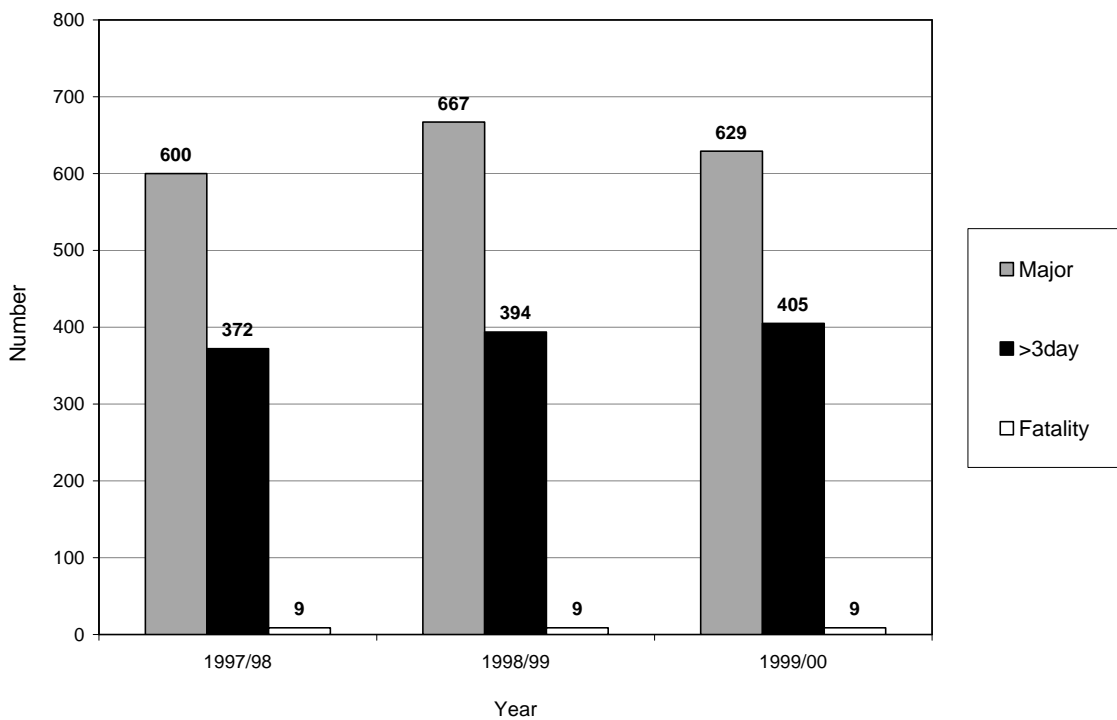

Figure 3
Reported ladder accidents in the construction industry

As can be seen from these figures, the numbers of accidents in the construction sector are far greater than those in other industrial sectors.

However, further research into the events surrounding these injuries is necessary to determine the reasons for this association.

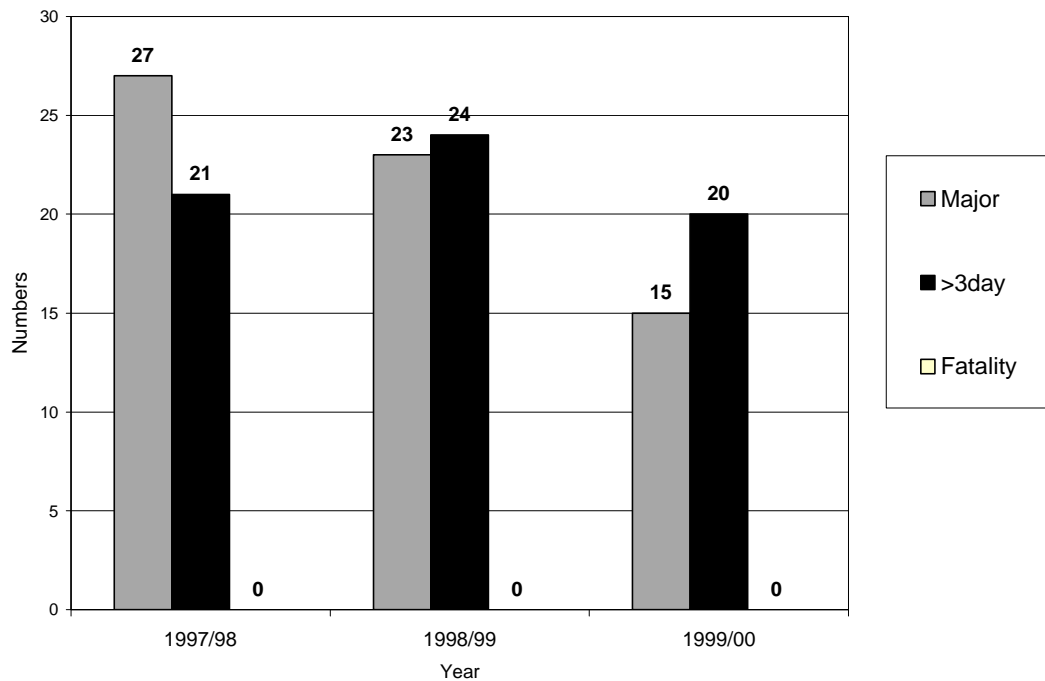

Figure 4
Reported ladder accidents in the energy industry

Figure 4 shows a decline in the numbers of injuries associated with the energy industry. From 1998 to 1999, there was a decline in serious or ‘major injuries’ in favour of slight or ‘over three day injuries’; a trend also reflected in the manufacturing industry (Figure 5).

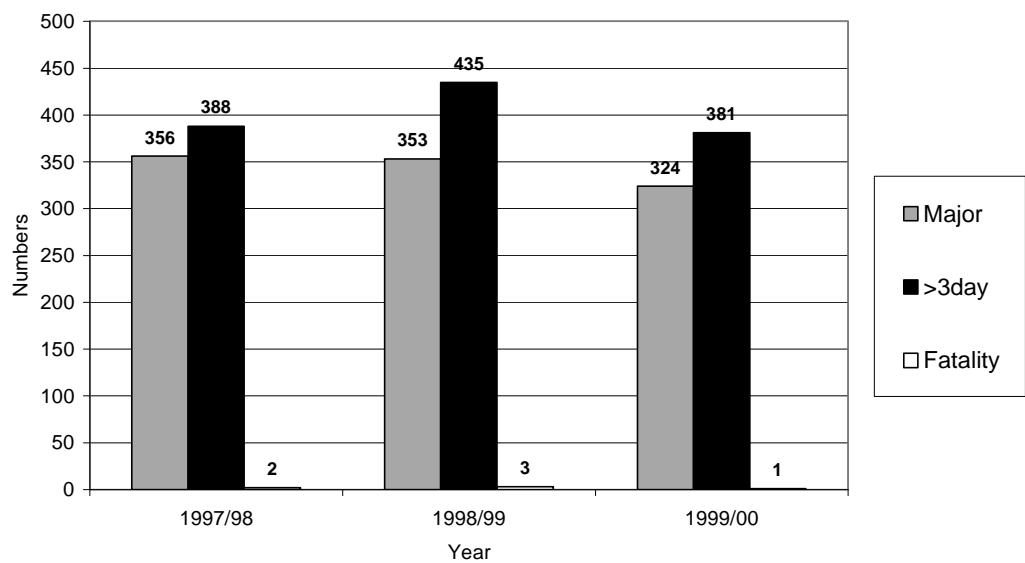

Figure 5
Reported ladder accidents in the manufacturing industry

It would be useful to know whether this decline is a true reflection of events or whether it is a result of other factors, such as a change in the reporting of injuries, a change in the nature of health care provision, changes in the size of the workforce or other such variables. If such variables could be excluded, with the same end result, then this might be an area for further research, in order to determine the reason for the reduction in major injuries.

2.1.4 Injury Profile

Table 2 describes two types of falls, namely low and high falls. A low fall is defined as a fall below two metres, whereas a high fall is a fall from a height above two metres (Health and Safety Commission, 2000). Interestingly, it appears that there are more low falls causing serious injuries than there are high falls. This is true for the construction and agricultural sectors. This situation is confirmed in other research in which it is reported that falls from relatively low heights are frequently serious, and it is not unusual for falls from 1.2 m (4 ') to be fatal. In an analysis of fall accidents, Snyder (1977) showed that people who fell less than 6 m (20') landed on their heads 76% of the time. However, people who fell more than 6 m landed on their feet 63% of the time. In relatively short falls, the head is more likely to be injured than in the higher falls.

Table 2
The relationship between injury profile and distance fallen.
These figures only includes accidents where the type of fall has been specified

Industry	High Falls		Low Falls	
	Serious	Slight	Serious	Slight
Agriculture	52 (66%)	27 (34%)	57 (59%)	40 (41%)
Construction	891 (69%)	405 (31%)	891 (57%)	670 (43%)
Manufacturing	447 (63%)	262 (37%)	514 (39%)	819 (61%)
Service Industries	383 (57%)	289 (43%)	492 (39%)	769 (61%)
Energy	23 (68%)	11 (32%)	37 (44%)	47 (66%)
Total	1796 (64%)	994 (36%)	1991 (49%)	2345 (51%)

However, once the total number of falls is considered, it can be seen that there are approximately 1500 more low falls than high falls. Furthermore, after adjustment for exposure, it may be anticipated that high falls will lead to a higher percentage of more serious injuries than low fall accidents.

This is confirmed by Figure 6, which shows that high fall accidents account for the majority of major injuries, and low fall accidents result in more slight injuries.

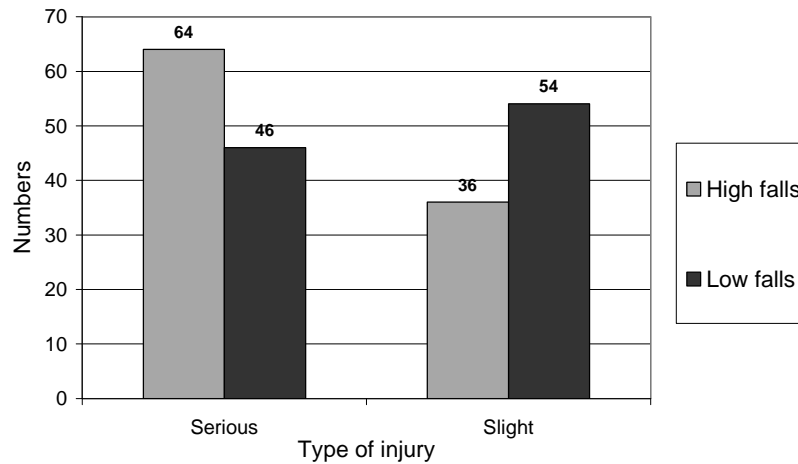

Figure 6
Percentage of total number of accidents by severity and height

2.1.5 Falls in the Construction Industry

Data from the HSE (HSE Presentation, 2001) on the fatalities in the construction sector between 1997 and 2000/01 showed that the most common cause of fatal accidents within this sector occurred as a result of a fall (52%). Of this, 23% were falls from ladders, although the type of ladder is not specified. The occupational groups most affected are shown in Figure 7 with painters and decorators being the most common victims of fatal falls from a ladder.

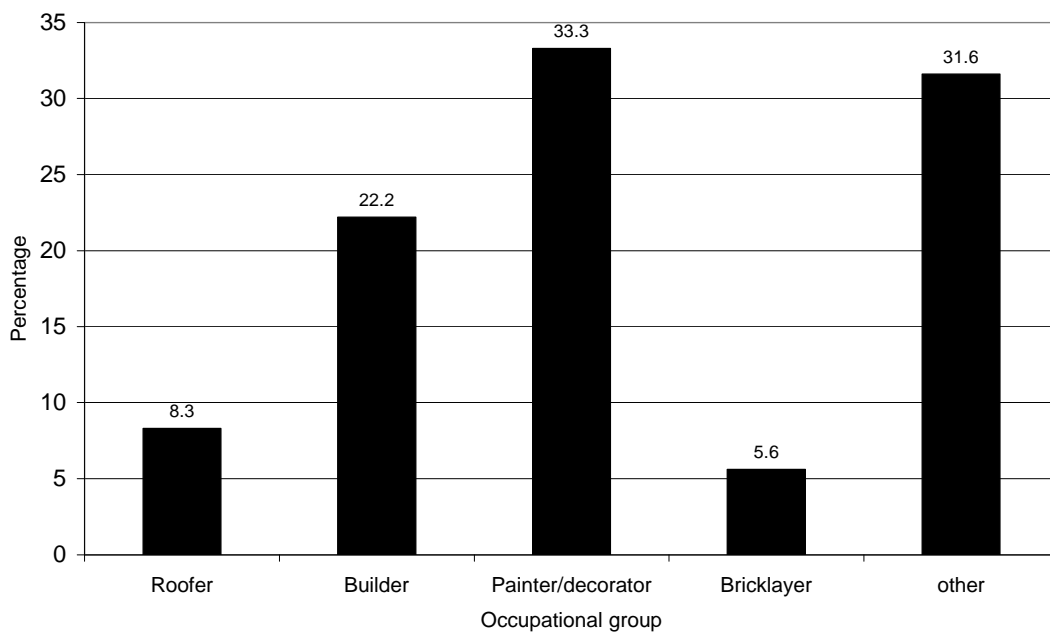

Figure 7
Falls from ladders by occupation

The causes associated with the falls given in Figure 7 are as follows:

- Untied or unsecured ladder (33.3%).
- No known cause (20.5%).
- Over-reaching (12.8%).
- Slipped/lost footing (7.7%).
- Defective ladder (5.5%).
- Knocked off (5.1%), over-balanced (5.1%), scaffold overturning (5.1%).
- Dismantling (2.6%).
- Age of victim (2.6%).

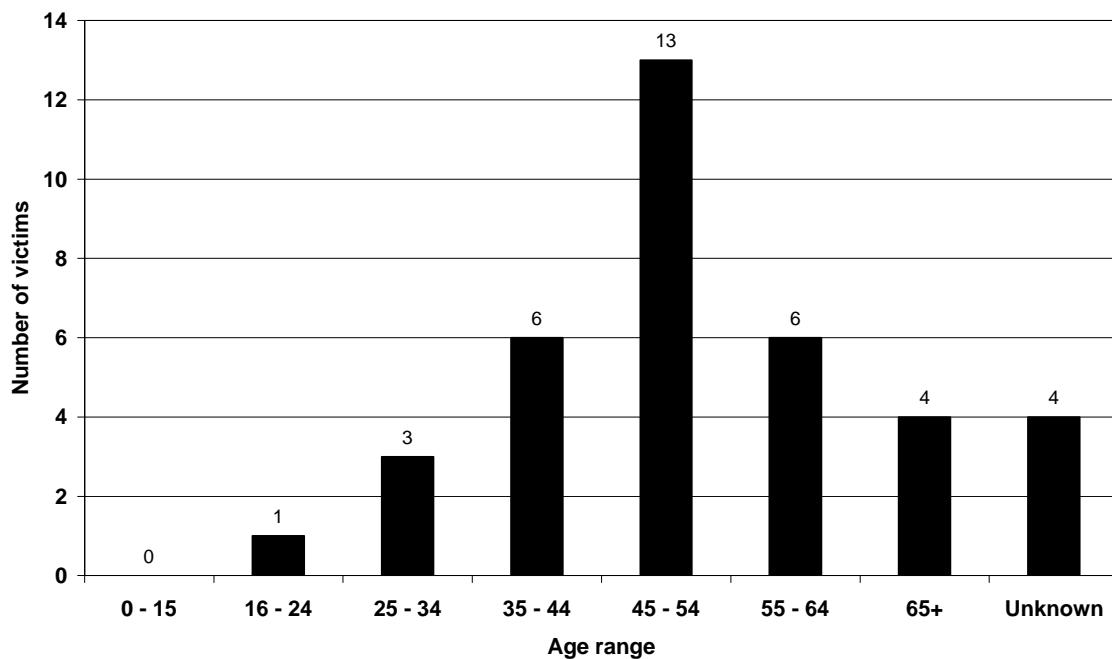

Figure 8
Ages of victims of fatal ladder fall accidents

Figure 8 shows the age range of those victims falling from ladders. This data shows a narrower age range than presented in the MARCODE data.

2.2 OTHER DATA ON LADDER ACCIDENTS

2.2.1 European Data

Björnstig and Johnsson (1992) found that work-place stepladder accidents increased in frequency at the beginning of the week, with a clustering of injuries at the beginning and end of the working day. This could be due to acclimatisation and fatigue periods, within which the users are more vulnerable to a fall.

The injuries sustained at work were more serious than those occurring during leisure time, potentially due to the harder floor surfaces. The study also found that 25% of accident victims were injured when falling against an object under or around the stepladder. Other injury scenarios exist, 20% reported having injured themselves against the stepladder itself.

Axelsson and Carter (1995) reported that nearly 5% of all reported occupational accidents (600 per year in the Swedish Construction Industry) are stepladder accidents. The aim of their report was to develop measures to prevent portable stepladder accidents in the construction industry, primarily in the form of alternatives to portable stepladders.

Approximately 10% of falls occurred during descent, while the victim was taking the final step, regardless of ladder type. Despite the low fall distances involved, the result was often a serious injury. The authors speculated that the final step is particularly hazardous since the individual cannot easily visually perceive the transition from ladder to surface. Furthermore, the distance from the surface to the bottom rung was consistently less than the standardised distance between the remaining rungs. The point was made that despite building codes, which require stair risers to be equidistant throughout, there are no comparable requirements for ladders. The quality of ladders in use within the Swedish construction industry appears to be high, as mechanical failure was rarely reported as a contributing factor to the occupational accidents studied and almost all ladders reportedly met Swedish ladder Standards.

2.2.2 Australian and American Data

A paper by The Victorian Workcover Authority (2000), surveyed existing international research into the causal factors implicated in ladder accidents, in order to inform the development of regulations to control the hazards. The literature investigated was mainly from the USA and Sweden.

Cohen and Lin (1991) undertook an eighteen-month epidemiological study of workplace accidents involving portable stepladders. The subjects were drawn from a database of workers returning to a hospital Casualty Department. A random control group of workers, who had not experienced a stepladder accident, was also selected from the same companies. Using univariate analysis, a number of risk factors for a stepladder accident were identified. These were then analysed in order to determine their impact as predictors of stepladder accidents. Workers on the evening or night shift were six or seven times more likely to be involved in an accident; they tended to work longer hours and were less able to control their flow of work; their work often necessitated great strength but was often considered as 'boring'. This suggests that fatigue and greater exposure to the hazard may play an important role in accidents.

Stepladder accidents were also nearly five times more likely to occur on a slippery surface, of which the worst performer was concrete. There were also non-significant indicators. For instance, those involved in accidents were more likely to be stressed about home and financial matters, and also likely to engage in risk-taking behaviour.

Janicak (1998) inspected the OSHA fatality records of the US construction industry in another study, which indicated that approximately 20% of all fatalities in the US construction industry were due to falls from stepladders.

2.2.3 Conclusion

The workers most commonly involved in accidents are painters and decorators within the construction industry, between 36 and 55 years of age. However, other industries and activities also appear to contain a high level of risk. Because of this it may be useful to investigate the nature of mechanisms and events surrounding 'major' and 'over three-day injuries', in order to determine the causal factors for the relationship between industry and injury profile, as well as the reasons for any changing injury profile. This may involve the collection of more detailed data than is presently required under RIDDOR. Finally, work-related accidents seem to be more frequent at the beginning of the working week and fatigue and organisational factors have also been implicated with the causation of ladder accidents.

2.3 STEPLADDER ACCIDENTS IN A DOMESTIC SETTING

Approximately 30,000 people in the UK attend an accident and emergency (A&E) department of a hospital each year following a fall from a stepladder. It is the third most common cause of injury (DTI, 2000). The high level of accidents involving stepladders prompted a report in 1996 into the safety of stepladders by the Consumer Safety Unit (CSU), now the Consumer Affairs Directorate (CAD) of the Department of Trade and Industry (DTI). They found that the injuries can be serious and can also cause longer-term health effects. (DTI, 1996)

2.3.1 UK HASS AND LASS Data

Data was obtained from the Home Accident Surveillance System including Leisure activities (HASS & LASS data 1998). Table 3 presents a summary of the numbers and types of stepladder involved in accidents, where the ladder type is specified. It can be seen that stepladders are involved in the highest numbers of accidents, of all ladder types.

Table 3
Numbers and types of ladders involved in accidents

Ladder type	HASS count	LASS count	Total count	Total National Estimate
Leaning	264	12	276	5 390
Stepladders/ Steps	677	21	698	13 632
Loft ladder	131	2	133	2 597
A-frame ladder	144	4	148	2 890
Other ladder	112	22	134	2 617
Unspecified ladder	780	95	875	17 088
Scaffolding/tower	75	68	143	

2.3.2 Ladder and Stepladder Survey 1988

Hitchcock and Stroud (1988) carried out a survey on behalf of the CSU, into ladder and stepladder use in the home environment. The aims were to find out what ladder types were being used, how they were used, and for which tasks. This survey included details of ownership and storage, in addition to any accidents suffered during ladder use. The authors carried out a nation-wide telephone survey of 255 ladder users, and 15 visits were undertaken to observe people first hand, using their ladders at home. An additional 419 reported accidents were selected from the Home Accident Surveillance System (HASS) database for further analysis.

It was found that 73% of those people suffering an accident were male, aged between 20 and 50 years old. Surprisingly, victims aged 61 and over had the next highest incidence of ladder accidents (25%). These accidents occurred mainly during house repairs or renovation-related (DIY) or maintenance activities and took place more often outside the house (55%). Cleaning windows accounted for 10% of accidents.

2.3.3 Review of Ladder Accident Data 1988/89

The Research Institute for Consumer Ergonomics (RICE) carried out a review of DTI Home Accident Surveillance System data (HASS) on ladder accidents for the years 1988 and 1989 (DTI, 1997). This was done in order to understand the trends and user groups involved, and to provide a basis for the design of user trials into the stability of ladders. In total, 2,797 incidents were studied over the two-year period.

Accidents were found to affect a larger age group than previously thought; being evenly spread between the ages 20 to 69 years.

Males were still the largest group affected (75%), with the majority of accidents taking place outside. Stepladders were the main ladder-type involved in 76% of all known accidents. Stepladders were the ladder-type used in 91% of incidents with women, however most of these accidents took place inside. The main activities for all accidents were household maintenance, cleaning and gardening.

Following this, HASS data was compared with PORS data (Dutch home accidents). The main findings were similar, except that there were a greater number of females in the PORS analysis (40%).

2.3.4 Consumer Safety Unit Study 1996

Lawrence et al (1996) carried out a further assessment of the safety of stepladders, for the CSU. This was commissioned due to concern about the large numbers of injuries each year involving stepladders. There are around 14,000 people injured and 50 fatalities in the UK each year, in accidents involving stepladders. Men were still the group most affected (over 55 years old), which supports previous research. It was further noted that the annual injury rate had not altered significantly in the last 6 years.

A user profile was established via in-depth interviews with 329 users of stepladders (defined by using a stepladder at least once a year). From this, they found that males and older respondents were more likely to be the main users. Males reported using a stepladder twice as much as females. Consequently, there were a greater proportion of males (61%) than females involved in ladder accidents. The 55-64 year old age group was reported to be the most frequent user group (3 times a month). This may account for the higher incidence of accidents in older users.

Details of the tasks performed using stepladders were obtained. Over half the respondents said they used their stepladder for painting and decorating. Most popular additional uses were DIY and cleaning, and gaining access to a loft or different levels. Two thirds said they had used the stepladder in the garden, at some time.

The HASS data scrutinised in this report showed that around 27,500 people attended A&E each year in the UK, following a fall from a stepladder at home. The numbers of people who subsequently required treatment was approximately 14,000. No age group showed prevalence, but men had twice as many accidents as women, which again corresponds with previous and subsequent data.

LASS data recorded that around 1,600 people in the UK attended A&E each year, following a fall from a stepladder. Data concerning the location of the accident showed that the numbers of accidents occurring inside and outside were fairly similar. However, 414 accidents were recorded as “unspecified home” and could have occurred either inside or outside. The most common activity was recorded as DIY and/or maintenance (512 cases). There were, nevertheless, 628 cases where the activity was not specified.

2.4 EUROPEAN DATA

2.4.1 Ladder Accidents In Sweden

Björnstig and Johnsson (1992) analysed data on ladder accidents in Sweden. Here, there were between 5,000 and 6,000 leisure-use ladder accidents per year, and 2000 work-related use accidents. These figures only relate to accidents requiring hospital care. The authors reviewed the hospital records of 114 ladder accidents, occurring between January 1985 and March 1986. The figures showed a higher proportion of males (81%) than females injured, than had been previously found in the UK. The average age of victims was 42 years old, which does correspond with previous research

2.4.2 The International Consumer Research And Testing Ltd (ICRT)

The ICRT (2000) carried out a large-scale, in-depth study funded by the Directorate General XXIV of the European Commission to undertake research into the safety of ladders. ICRT is an association of 26 consumer organisations from 22 countries, mostly in Europe. Their remit is to provide impartial and objective consumer information. The aim of the study was to address the safety hazards associated with the construction and use of portable ladders and make recommendations for improvements in the safe use of ladders and stepladders. The project was carried out in collaboration with 14 independent consumer organisations from the Member States of the European Union. Accident data were obtained from 9 countries. Details of 12,327 portable ladder accidents occurring in the domestic environment over the period 1987 to 1997 were collated. It was found that only limited information on ladder type was provided by some countries: The ladder type was not known in 71% of Finland’s accidents and 61% of Sweden’s. The data from the Netherlands showed that the accidents were split between leaning ladders (48%) and standing stepladders (52%).

Details of the severity of injury were obtained for 7,080 cases, which showed that 64% of accidents were severe; requiring immediate professional medical attention and follow up treatment or in-patient care. A further 28% were moderate, requiring professional medical attention after the accident occurred, 7% were slight and 12 accidents were fatal.

This seems like a low figure, more so as it is measured over twelve years, considering there are 50 fatalities per year, in the UK.

The authors were able to obtain details of 37 individual accidents from Finland. These revealed, males, aged between 30 and 70 years old to be the main victims involved in 57% of all accidents. Whereas, children aged between 3 and 9 years are involved in 19% of accidents. Of the accidents involving females, 56% occurred whilst they were using step stools.

Information gained from France, where the national estimate for portable stepladder accidents is 70,000 per year, showed an unusually high association of younger people with stepladder accidents: about 60% of those stepladder accidents associated with people less than 20 years of age, were a result of play activities. The percentage of males involved was found to be similar to other studies (73%), with DIY activities accounting for 58% accidents.

In the Netherlands, 50% of those involved in stepladder accidents were between 25 and 54 years of age, and males (60%), were still affected more than females. Of the accidents involving males, DIY was the activity most commonly associated with a stepladder accident, and 80% of these took place within a domestic environment. Of the accidents affecting females, the majority took place during domestic activities, such as window cleaning and curtain hanging.

Results from Sweden indicated that stepladder accidents in a domestic setting were twice as common as occupational stepladder accidents, and that 77% of domestic ladder accidents occurred outdoors. These results conflict with Partridge (1998) who, after analysing UK data, found 50% of accidents to be occupationally related.

Four countries provided information on activity when the accident occurred; Finland, Netherlands, Portugal and Sweden. However, although Finland provided information, in over 50% of the cases the activity was not known. The categories that were indicated by ICRT, other than “not known” and “other”, were:

- Outdoor painting
- Indoor decorating
- Outdoor maintenance
- Carrying a ladder
- Moving a ladder

The latter two categories do not appear to be related to the task being performed whilst on the stepladder.

Of the cases allocated to one of the categories: outdoor painting, indoor decorating and outdoor maintenance, painting outdoors appears to be the most common activity. This concurs with the data on occupational sector involvement.

2.4.3 Conclusions

Stepladder accidents are responsible for large numbers of injuries across Europe, with France and United Kingdom's combined accident total estimated to be 100,000 per year. Males aged between 20 and 60 are most likely to be affected, however, the incidence is highest between the ages of 40 to 60. The activities most commonly associated with domestic stepladder accidents are outdoor, DIY and maintenance. Women suffer approximately 30% of accidents, of which a very high proportion involve stepladders (91%) and which are mostly inside a house.

2.5 CAUSES OF STEPLADDER ACCIDENTS

2.5.1 Failures Due To Defects

There are two types of possible causes for defects (Goldsmith, 1985), which may result in a stepladder failing: manufacturing defects and design defects. Manufacturing defects occur when the materials or workmanship of a stepladder is faulty, and may be prevented by adequate quality control. Design defects occur when safety features or specifications for the materials or manufacturing process are insufficient to prevent a stepladder failure. The critical point is made that a design is particularly defective when a failure occurs during types of use which are either promoted or intended by the manufacturer, or which could have been readily anticipated by him.

Goldsmith studied accident data (50 cases), and found the majority of failures were with aluminium stepladders and more often with extension ladders than stepladders. Of the 19 stepladder failures, the modes were:

- rail (or stile) failure with aluminium ladders (42%)
- bracing (support between rung and stile) failure with aluminium ladders (21%)
- unstable condition with aluminium ladders (16%)
- unstable condition with wood ladders (5%)
- cuts from sharp edges with aluminium (5%)

Rail and brace failures included bending, breaking or twisting of these structures, due to a lack of strength for the load imposed on them.

Occasionally both rails and braces failed in the same accident; however, it was usual for one to fail first leading to the failure of the other, due to the consequent transfer of force. This type of failure, however, has been difficult to reproduce within a controlled environment.

It is possible that age and 'wear and tear' of the stepladder may contribute to these stepladder failures. Previous research has only been carried out on stepladders purchased specifically for testing and has not considered real life ageing and storage. However, the data shows that many stepladders are over 16 years old (Hitchcock and Stroud, 1988).

2.5.2 User Behaviour

In contrast, however, a study by Hitchcock and Stroud (1988) contradicts the work of Goldsmith; showing less than 5% of the 419 accidents studied, actually resulted from a stepladder failure, and thereby allocating the responsibility for the initiation of stepladder accidents to the user.

Similarly, Lawrence et al (1996) analysed data from Trading Standards and Environmental Health Officers. This study showed the most commonly reported damage consisted of buckling to the bottom of the stile. Therefore, as damage consistent with a sideways fall appeared to be the most common or probable type of mechanical failure, a testing programme was designed to include a method of inducing this type of failure. The aims were to see at what point, if any, buckling occurred during a fall, and to allow comparison of stepladder design. Tests, however, failed to reproduce these results; thus mechanical failure was deemed unlikely to be a major cause of accidents. It was suggested that the most common accident scenario appeared to involve the user mis-stepping, slipping and over-reaching or the stepladder slipping or tipping. It was recommended that design changes should incorporate design solutions to reduce overreaching, and reduce the need for sideways use.

Partridge et al. (1998) carried out a retrospective study of victims of stepladder falls, in order to investigate causes and outcomes of stepladder accidents. The medical records of patients attending hospital between January 1993 and December 1995 were reviewed. Wherever possible, the patients then underwent a structured telephone interview to provide additional information about the circumstances of their fall. There were 59 patients who sustained injuries after falling from a stepladder. All were adults aged between 26 and 59 years of age, predominantly male (93%). This is a much higher figure than found previously. The victims had all fallen a distance of between 1 and 15 feet. Fractures were observed in 36% of the cases and there was no relationship between distance fallen and the occurrence of a fracture. Out of 59 patients, 42 were interviewed.

Most falls (79%) were attributed to excessive reaching or incorrect stepladder placement. The authors concluded that simple safety measures might have prevented the majority of the falls in this study. They went on to recommend that public health efforts should emphasise education on safe stepladder practices and techniques, to reduce the possibility of injury in the event of a fall.

2.5.3 Stepladder Slippage

Hitchcock and Stroud (1988) reported that 5% of accidents studied are known to have resulted from a stepladder slipping. Similarly, Björnstig and Johnsson (1992) found that 41% of leaning ladders slid to the ground, whereas 48% fell sideways. In most cases, this was attributed to reaching out too far sideways or an unintentional movement of the ladder. In the case of stepladders it could be inferred that the ladders might have been used parallel to the task, which is often described by the ladder manufacturer as ‘misuse’. This issue is discussed in Section 3.4.2.

Axelsson and Carter (1995) questioned 85 ladder accident victims in Sweden to obtain detailed information about factors contributing to the accidents. Accidents were divided between straight ladders (n=39) and stepladders (n=33). Their findings agreed with previous research in that tipping sideways was the most common preceding event with users of stepladders, and misstepping the final step while descending accounted for 10% of all accidents. Furthermore, for straight ladders, slipping of the base was the most common event preceding the injury. Low angle of inclination was a common contributing factor.

In the large-scale study by ICRT (2000) only 3 countries were able to provide information on the causes of the accidents. The Netherlands reported 88% of accidents were due to the user slipping. The causes of the remaining 12% were not known. Table 4 presents causation, as reported by Finland and Sweden. The actual number of accidents was not given, the data being expressed as percentages.

Table 4
Reported causes of stepladder injuries in Finland and Sweden

Causes	Finland (% of accidents)	Sweden (% of accidents)
Top of stepladder slips	3	2
Bottom of stepladder slips	5	9
Stepladder tips	2	10
User slips	18	55
Defect on stepladder	4	2
Other	0	6
Not known	68	16

It can be seen that the most common recorded cause of an accident in Finland and Sweden is due to user slipping, although the precise mechanism is unclear.

2.5.4 Other Data on Causes of Occupational Accidents

A study by Janicak (1998) reinforced a number of other studies (Axelsson and Carter, 1995; Tyrens, 1980; Vira, 1979), which show that stepladder accidents occur more frequently while the victim is working on the stepladder, rather than using it as a means of access or egress. Over-reaching (reaching overhead or over-extending the body beyond the handrail of the stepladder) is the most common accident pattern across all ladder types, accounting for 19% of all accidents investigated. This also concurs with the findings of Cohen and Lin (1991), who showed that workers are often in awkward or difficult positions at the time of an accident.

Similarly, a study by the Health and Safety Laboratory (HSL, 2000) showed that the most common accident types are those in which the stepladder slips or the user falls from the stepladder. In instances where the users falls, access may be an issue. Stepladder failures are more rare. However, where they do occur, the stepladder maintenance procedure is a causal factor. Organisational factors contributed to over two-thirds of accidents (67.9%). This category included systems of work, as well as training. Important employee factors included misuse of equipment, operator error and failure to comply with instructions. Key physical factors include access or egress problems and defective equipment.

2.5.5 Conclusions

User-related factors are by far the largest cause of accidents. These have been listed as mis-stepping, slipping and over-reaching, and may also result in the stepladder slipping or tipping over. Additionally, there are a variety of factors implicated in accidents, such as manufacturing or design defects. However, research has shown that design defects are much more common than manufacturing defects; a design defect (a design which does not take into account types of use, commonly employed by the users) would seem to be a critical issue for the stepladder industry.

2.6 STABILITY TESTING

Considering the high number of associated accidents and fatalities each year, there has been relatively little research into the area of stability testing of stepladders. Importantly, it is an area which is not included within BS 2037 : 1994 Portable aluminium ladders, steps, trestles and lightweight stagings or BS EN 131 : Ladders. Several studies have attempted to address this issue.

2.6.1 UK Studies

The CSU published research (DTI, 1997) carried out by RICE in 1993 to investigate issues relating to the use, performance, and testing of domestic ladders (Class 3), which included leaning ladders, combination ladders and stepladders. With reference to stepladders, they found conflicting advice on the ladders regarding the safety of the top tread for standing. Sources also conflicted regarding whether one or two hands should be used to hold on to the ladder when climbing. Regarding reaching, recommendations varied from 'do not lean out at all', to 'do not overstretch or lean out too far/excessively'.

The authors concluded that several of the recommendations made for safe use were vague and open to wide interpretation by users. A fundamental criticism was that recommendations often represented the ideal, and failed to give safe alternatives when ideal use was not possible. As the accident analysis showed that 76% of accidents involved stepladders, safety recommendations were criticised for relating to all ladders, rather than targeting use of stepladders. In addition, current safety advice and static tests for ladders did not appear to be preventing ladder accidents, as ladders built to comply with the Standards appeared to be failing under normal conditions of use.

The study aimed to establish the dynamic circumstances surrounding the use of domestic ladders, with particular reference to accidents, and normal use and misuse of ladders, in order to determine whether the current static ladder tests adequately predict the performance of ladders in real life. Whilst the study focussed on leaning ladders, some findings emerged relevant to all ladders.

- Any movement of the ladder (e.g. flexion of the structure) threatened the confidence of the user, the security of footings and the mechanical integrity of the ladder.
- Users generated forces in excess of their own body weight, through accelerative forces whilst climbing ladders. These were as high as 150% of the user's weight in the axial plane of the ladder; namely, down the ladder stiles.

Issues relevant to angle of leaning ladders were as follows:

- Reducing the angle of use reduced the frictional security of the ladder.
- Reducing the angle of use placed significantly higher loading levels on the ladder in the normal plane (at the preferred angle users were less careful on the ladder).
- There were no significant differences between side loading levels at 66° and 75°.
- Sway of the ladder platform in the normal plane is worse at 66° than at 75°.

- Sway of the ladder platform in the lateral plane was independent of angle but modified by task type. The sway was worse for reach tasks and relatively unchanged for lifting tasks. The user responding to the feel of the ladder accounted for these changes.
- Stress upon the ladder in the normal plane was higher (40%) at 66° than at 75°. Approximately 15% of this can be accounted for by changes in geometry, the rest by user behaviour.
- Stresses in the lateral plane were unaffected by changes in angle.

The recommendation was made for a slip resistance test when the ladder is set at 66°, in order to challenge the ladder design with ‘real life’ situations. It was further recommended that dynamic testing should be incorporated to type-approve ladder models for acceptable levels of stress and movement, as well as to test for endurance against a cyclical force.

DTI post research comments (DTI, 1997) stated that the ‘Slip Factor’ and ‘Dynamic’ test requirements would be addressed in the forthcoming revision of the European Standard (EN 131 parts 1 & 2). The DTI argued, that dynamic testing of production samples of ladders for endurance was not considered necessary, provided the Classification for Use, used in the old British Standards, was included in the European Standard. The reason for this was that the maximum static vertical loads, quoted in the Standard by the Classification categories i.e. Class 1, 2 and 3, were arrived at by taking into account not only the loads expected, but also the variations of endurance expected in the three classes. However, the origin of the values for the Classification categories is not patent and the work demonstrated that loads greater than the user’s own weight could readily be generated in use. It was also suggested in this report that the nature of use for Class 3 (domestic) and Class 2 (light trades, now EN131) is unlikely to be substantially different.

2.6.2 European Studies

The most recent research into the stability of stepladders was carried out by the ICRT (2000). The test programme was based on EN 131, with the addition of a number of consumer requirements not included in EN 131, for example the presence of user instructions, stability testing of portable stepladders and requirements for accessories. They tested a total of 243 ladders, of which 126 were stepladders, comprising 42 different brands. Each brand was tested using three samples. The results showed that only a few models met the requirements of EN 131. Moreover, when applying the requirements strictly, about 50% of products failed, and 67% of stepladders received a final rating of ‘below average’. Only 33% of stepladders met the requirements of EN 131, as well as consumer requirements.

Some of the reasons given for failure included lack of strength of steps, rungs and platforms. Also the materials did not meet minimum thickness requirements.

Most products did not have adequate labelling. It was also recommended that EN 131 be adopted as the Standard for portable stepladders in all EU countries, but that it should contain stability and durability tests. Furthermore, the test loads should be reconsidered, to ensure the safety of the consumer. The final point made was the need to include in the Standard requirements for stability under normal working conditions.

Recommendations for further work included:

- The assessment of subjective safety and acceptability levels.
- The development of a dynamic test to investigate levels of force and movement generated by users.
- Ongoing, random, quality control endurance testing for all stepladders.

2.6.3 Design Recommendations

Björnstig and Johnsson (1992) cite a suggestion by Jüptner (1976), to prevent the sideways toppling of stepladders; namely that ladders should be broader at the bottom than at the top. This would help prevent the centre of gravity from moving outside the ladder-footprint. However, the authors also believe that there is a need for further development of ladder construction, particularly to reduce the risks of slipping or tipping of the ladder, or slipping and tripping on rungs or steps by the user. Furthermore, improvement of safety accessories (e.g. slide protection) to suit older types of ladders would be valuable.

Axelsson and Carter (1995) proposed two design modifications that would improve ladder safety. These were: stabilisers on the base of ladders, and equi-distance between all rungs, including from the ground surface to the first rung. They argued that there is a need for improved user education. None of the occupational users interviewed in the study recalled receiving any information about safe ladder use and few were familiar with the risks associated with low angles of inclination when using leaning ladders. In addition, few were aware of the potential safety benefits provided by simple mechanical supports.

Ladder manufacturers were criticised by Goldsmith (1985) for continuing to produce ladders with minimal safety features, despite the fact that 65,000 people each year in the USA were estimated to suffer injury associated with the use of a ladder. He stated that until manufacturers are forced to meet higher levels of safety in the stepladders which they market, inferior and hazardous stepladders will be produced, purchased and used by the consuming public. He subsequently suggested improvements to stepladder design, to increase safety and reliability.

The display of warnings was given as a simple design feature to prevent accidents. However, it is pointed out that these must be placed where the user can easily see them and take the appropriate precautions. He recommends the use of adequate quality control to prevent mechanical failures and improvements to the design in order to make the parts stronger. He described the use of gusseting, bracing or increasing the cross-sectional modulus as methods of supplying the necessary strength to prevent failures. However, this should be seen in the light of more recent research, which suggests that mechanical failure of a stepladder is a rare occurrence.

Lawrence et al (1996) also suggested that work should be done on design solutions to reduce over-reaching, provide feedback on over-reaching and instability and reduce the need for sideways use. Other design aspects to be reviewed included methods to reduce slipping and misstepping and improving balance and ease of assembly, particularly of combination ladders. Furthermore, it is recommended that any design changes are reviewed with a view to overall safety and not just reducing injuries from falls.

2.6.4 Conclusions

Despite the high numbers of victims suffering the consequences of a fall from a stepladder, there has been very little research into the area of stability of stepladders. Yet the stepladder accident statistics suggest that there is a need for research into this area, in order to understand the performance of stepladders when challenged with real-life use.

This would appear to be at least partially substantiated by the number of stepladder accidents reported to Trading Standards Officers alleging that the stepladder failed whilst in normal use. If such failures were occurring without user misuse, the design of stepladders currently available to the public must be brought into question. In the majority of such cases, consumers allege that they were not misusing the stepladder in any way. Such widespread conviction further suggests that either the stepladders involved are faulty in some way or that the user's perception of reasonable use does not match that of the manufacturers. Stepladder manufacture is largely controlled through the application of voluntary British and European Standards. The UK differs somewhat from other European countries in offering a Standard specific to stepladders intended for domestic use (BS 2037 : 1994). However, the European Standard (BS EN131 : 1993) does not discriminate between 'domestic' and 'light trades' use. This discrepancy is the subject of considerable debate.

In addition, current Standards do not contain a requirement for dynamic testing.

Static deformation is clearly an essential part of an effective testing regime, but may not be sufficient on its own to ensure adequate safety in a product which may be in use for many years and which may have a finite fatigue life. Indeed, it would seem appropriate to ensure manufacturers design stepladders, which can withstand use in the consumer's preferred mode by means of design tests and Standards that reflect this.

2.7 OVERALL CONCLUSIONS

Despite the studies conducted, and the knowledge gained, stepladder accidents are still responsible for huge numbers of occupational and domestic injuries across Europe. This demonstrates that the existing safety Standards could be improved to address the real users and uses of stepladders. The highest incidence of accidents is seen amongst males between of 40 and 60 years of age, who are the main users of this equipment with common activities being DIY and maintenance. However, all studies of domestic users consistently report approximately one third of victims to be women. Workplace statistics (pertaining to ladders in general) show that the construction and agricultural industries have the highest incidence of ladder accidents, with painting and decorating as the occupation most commonly suffering fatalities.

Most households own a ladder, which is likely to be an aluminium stepladder with 5 or 6 treads. This is the type of ladder is most associated with accidents, of which the commonest are the user slipping or falling.

There is clearly a range of activities which the ladder user may undertake which, whilst undesirable, fall within the diversity of normal use. These present a challenge for the manufacturer, since they do not want the user to undertake these activities, but must accept that they will. This is normally termed 'reasonably foreseeable misuse'. A popular example is that of a flat-bladed screwdriver. As a tool, its primary intention is to insert and remove screws, but virtually any user asked will report that it is also used to open tins of paint. This use must then be considered 'reasonably foreseeable'.

There is some skill necessary in defining the borders between foreseeable misuse and abuse, and manufacturers may require outside expertise in order to achieve the necessary balance. Again, in respect of the screwdriver, opening tins of paint may be foreseeable misuse, whereas use as a chisel (or, worse, use as a weapon) may be considered abuse.

This distinction has important implications for a manufacturer. Current legislation requires that their products must be safe in conditions of normal use or reasonably foreseeable misuse.

This means that the manufacturer must appraise the range of tasks that will be undertaken with their product, and design it such that it presents the minimum of risks in these situations. This precludes product manufacturers from applying numerous warnings to their products advising users not to undertake activities, which they quite patently will do. Failure to enact these responsibilities can culminate in the manufacturer facing criminal prosecution in addition to civil liability claims.

3.0 LADDERS

3.1 TYPES

In 1981, an appraisal of 26 stepladders on the American market (Consumer Reports, 1981) found that the most common size of ladder was 6 feet. Half of the 7 million stepladders produced every year were made of wood, and slightly less than half were made of aluminium. Some stepladders for industrial use were made of steel, magnesium or fibreglass. They tested 15 wooden and 11 aluminium stepladders in accordance with Underwriters Laboratories (UL) and American National Standards Institute (ANSI) for strength, rigidity (resistance to swaying and resistance to 'walking') and stability. They concluded that wooden stepladders were more rigid, strong, stable and a little cheaper than aluminium. However, aluminium stepladders required no special storage and were easier to manoeuvre. The major disadvantage of aluminium was its conductivity which made it potentially dangerous to use near electrical power cables or circuits.

Information about available brands and models of stepladder in Europe was obtained from a market survey by ICRT (2000). This was carried out across all participating European consumer organisations. It was found that nearly 200 types of portable stepladder were available. However, only a few of these were available in the majority of participating countries. Thus, a selection criteria was adopted, which included equipment that was both widely available, as well as popular on individual markets. Some steel stepladders were found, but aluminium stepladders were discovered to be the most common product.

Goldsmith's report (1985) focused on portable stepladders, as they were more often involved in accidents and there were more falls from stepladders (54%) than leaning ladders (46%). Stepladders were found to be manufactured in various lengths, with the maximum height generally being 10 feet; beyond this they are considered to become unstable.

The materials used in their construction; ie wood, fibreglass or aluminium enables the further classification of stepladders. Aluminium stepladders are made of open shapes which can twist, fold or bend under too much stress, and be weakened from metal fatigue or bending due to rough use or handling. The main advantage for aluminium stepladders, however, is their low weight, which makes them easy to handle and carry around. Nevertheless, wood and fibreglass stepladders are generally considered to be safer than aluminium because of the risks associated with its conductivity (Goldsmith, 1985). A fibreglass stepladder outperforms others, yet it is disadvantaged by its high price.

3.2 OWNERSHIP

Hitchcock, D. and Stroud, P. (1988) in a telephone survey of 255 people, showed that most respondents (52%) use two ladders, 29% use only one ladder and 19% use at least 3 ladders. Most households owned these ladders (93%), with only a minimum being borrowed (7%). No ladders were hired. Of stepladders used, over 50% were made of wood, whereas over 50% of extendible ladders were made of aluminium.

Stepladders were much more popular than any other type of ladder; more than twice as many people used them. The majority of ladders were less than 10 feet high when fully extended. Most of all the ladders purchased (60%) were bought from DIY outlets. Small, DIY shops were the preferred purchase venue, rather than large retail outlets, such as a superstore. However, the preferred purchase venue is likely to have changed since this research was carried out, due to the rise in numbers and popularity of the superstores.

Stepladders were generally kept for long periods of time. Over 50% of the ladders were aged between 1 and 10 years, but 28% were more than 16 years old, which supports the need to test 'used' or second hand stepladders during research. In addition, there were more free-standing stepladders in the older category. Ladders were reported to be used regularly and frequently with 33% using a free standing stepladder at least once a month. Stepladders were used in over 50% of cases, for the widest range of tasks.

There were relatively few defects reported. The most common defect (18%) was mould or corrosion, which accounted for about 10% of stepladders. This may be due to the choice taken for their storage location. Only 13% of stepladders were stored in the recommended way (supported along the bottom stiles or by separate supports), whereas over 50% were stored by leaving them against a wall or similar. Very few ladder accessories were being used. These were mainly with leaning ladders.

A study by Lawrence et al (1996) showed that the number of British households owning a stepladder had fallen to 77%, a drop of 17% in eight years. The commonest type owned were one way, 5 or 6 tread, aluminium stepladders. A third of consumers owned combination (3 way) stepladders, and one third of consumers had stepladders higher than 6 treads.

3.3 EFFECTS OF STEPLADDER RUNG SHAPE, SPACING AND ANGLE

In a study by Juptner (1976) preferred rung shape for improved ladder safety was investigated. The study involved altering rung shape to see how it affected user behaviour.

The variable measured was the distance reached by the participant when putting bolts into prepared holes. The researchers found that the reach envelope was significantly reduced (11 cm) by a rung with curved sides.

McIntyre (1979) carried out a study examining the mechanics of ladder climbing with special emphasis on the effects of rung spacing and user characteristics on the ability of the user to ascend a ladder. The report argued that accidents where the user fails to negotiate the ladder safely (e.g. failure to locate one or more body parts on the ladder, or difficulty in co-ordinating movement patterns), may be due to factors beyond the control of the user. These factors might include the dimensions of the ladder or encountering unexpected distractions. The adoption of an inappropriate gait may be another factor.

In order to further analyse this, two experiments were carried out. The first was designed to ascertain the temporal characteristics and gait patterns used by participants when ascending a ladder; having received no instructions regarding climbing technique. However, the results of the initial study revealed little evidence to suggest a preferred climbing gait. The purpose of the second experiment was to examine the effects of rung spacing and specific anthropometric characteristics of the participant, on their ability to ascend the ladder using an experimenter-defined gait.

Twenty male participants were assigned to one of two ten-member groups according to their height. The mean standing height for the tall and short participant groups was 1.92 m and 1.71 m respectively. Each participant performed at least 3 trials; each trial corresponded to one of the following rung spacings:

- 0.305m (normal based on ANSI, 1972)
- 0.203m (narrow)
- 0.406m (wide)

The results showed that participants in the taller group spent less time in contact with the ladder rung, and more time in the airborne phase, compared to those in the shorter group. Furthermore, there were indications that users have a preferred rate of ascent which is maintained despite changes in the climbing apparatus.

Instances of overshooting of the target rung were found when rung spacing was 0.203m (narrow). This overshooting occurred only at the participants' feet. It was suggested that visual monitoring was a likely explanation for the hands being accurately placed.

The primary role of the hands is the maintenance of stability. This was shown by force data, which also demonstrated that for the short participant group, increases in rung spacing were accompanied by increases in forces applied. Additionally, there was also an increase in the parallel (side to side, known as ‘sway’) to perpendicular (up and down, known as ‘bounce’) force ratio for narrow and wide rung spacing. Thus, those ladders which have either narrow or wide rung spacing increase the forces required to safely ascend or descend thereby increasing the likelihood of a ladder-user being unable to exert the required hand-stabilising forces. However, the decreased effort required to ascend ladders with the narrower rung spacing would lessen the possibility of an accident occurring for this type of ladder.

Ouellet et al (1991) were not able to reproduce McIntyre’s effects (McIntyre, 1979). The authors investigated the biomechanics of stepladder climbing. They used an adjustable stepladder, on which the angle of the stile, the depth of the steps and the step spacing could all be adjusted. Table 5 shows the adjustment available.

Table 5
Variables tested and measurements chosen by Ouellet et al (1991)

Variables Tested	Measurements
Stile slopes (3)	65 °, 75 ° and 80°
Step depths (2)	75mm and 320mm
Vertical step spacing (2)	271mm and 310mm

The results showed an increase in the duration of the climbing cycle and the lifting phase when angles were greater. This implies that a stepladder set at a more vertical position (80°), represents increased effort on the part of the user, as well as an increased, perceived risk of falling. A slight increase in speed was noted when users were climbing a stepladder with a steeper slope. It was suggested that this occurred because the participants were trying to maintain their rhythm in spite of the increased difficulty of the task.

Step depth was not seen to affect the length of the climbing cycle or that of its pressure and lifting stages. Furthermore, it did not affect the joint angles of the legs. Vertical step spacing, however, decreased the load on one particular muscle (vastus lateralis) and had no effect on other groups. Thus, stepladder configuration did not seem to affect climbing pattern in any major way and expressing preferences for their design was considered to be arbitrary. Those

parameters showing the greatest number of significant effects were found to be the slope of the ladder, followed by vertical spacing and step depth, in decreasing order.

3.4 LADDER USAGE

3.4.1 Angle of Leaning Ladder Use and Stature of the User

An investigation by Dewar (1977) analysed accident consideration; particularly accidents attributed to misplacing of feet or 'stumbling' when climbing. On the basis of accident reports, Dewar noted that 66% of ladder accidents resulted from the ladder slipping, whilst the remaining 34% were attributed to the user misplacing his feet. The focus was on two factors which might affect the chances of an error of feet misplacement occurring; angle of ladder and stature of the user.

The study included analysis of displacement and rotation of pelvic girdle and trunk, as well as rotation of knee and hip joints. There were 35 male participants which were filmed climbing a ladder set at 70.4° and 75.2° to the horizontal. The body movements demonstrated whilst climbing were compared with the participant's normal walking gait.

Dewar found that when instructed to use one of two angled ladders people most commonly chose a 3:1 (vertical distance: horizontal distance) angle ratio. It was noted that, at a steeper angle, the user often experienced feelings of heightened insecurity due to a fear of falling backwards. This is combined with an increased awkwardness in climbing the ladder. This issue was further explored by Dufresne (1992) who found users consistently tended to use the ladder at lower than the recommended angles of usage. RICE (1997) also confirmed this during later research. The results indicated that when a ladder is set at a steeper angle the user's hands play a greater role in maintaining balance. With a steeper angled ladder Dewar found greater posterior displacement i.e. leaning further back from ladder. He concluded that the user's hands were contributing to stability of the body. If the hands were to slip there was less chance of the user regaining his balance. The study also found greater differences in body movements in tall and short participants. This may be due to the dimensions of ladders being best suited to the 'average' user. Therefore, users falling within the extremes of the size range have to modify their movements, which in turn leads to an increased risk of accidents. This agrees with research carried out by McIntyre (1979).

3.4.2 User Behaviour and Ladder ‘Misuse’

Observational data has shown that the manufacturer’s definition of ‘misuse’ would include much of the common use of ladders as many people ‘over-reach’ or ‘over-stretch’ due to the needs of the task in hand. It has also been shown that users routinely use the stepladders parallel to the task as opposed to perpendicular as instructed. This is a mode of usage for which current stepladder designs may not be ideal.

With specific reference to stepladders this may prove a challenging area. For instance, it is known that many users will orientate a ladder parallel to the work surface for ease of access. This is in contradiction to the intention of the manufacturer to use the stepladder perpendicular to the work surface for safety. There is a strong argument to say that merely advising the user not to utilise the stepladder in this configuration is failing to acknowledge this condition of reasonably foreseeable misuse, and that the correct resolution is to design the stepladder such that it may be safely used in this way. This argument does not dilute the need for effective warnings and labelling, moreover it precludes manufacturers relying on these to compensate for poor product design.

Furthermore, labelling which advises users against such ‘misuse’ seems to have little effect, seen by the constantly high accident figures. Users often do not read, or comply with, these warnings, wrongly perceiving the risk of an accident to be quite small. Tests have shown that the design and size of the stepladder may affect user behaviour and effort required. Thus, an improved design accommodating known stepladder usage may improve the safety and stability of stepladders. In order to assess this further it is recommended that stability testing is carried out under real-life conditions. This will facilitate understanding of the user behaviours and allow measurement of the forces generated, which might affect ladder stability. This will further enable the development of a dynamic test for inclusion within the Standard.

A paper by Erman (1986) reports his informal investigation of people’s awareness, understanding of, and compliance with, the warning provided with stepladders not to stand on the top step or top platform. The majority questioned said they did stand on the top of a stepladder, even those that were aware of the warnings to the contrary. The author pointed out the futility of displaying warnings which have an unrealistic expectation of compliance. Attention is drawn to an improved design available on the European market for at least 20 years. This has a stepladder with a handrail either at the top or on the side 30 to 36 inches above the top step. This allows the user to maintain balance either by holding on to the handrail or leaning against it. Erman (1986) further justified the comments by detailing the negligible costs involved in implementing such a design modification.

The author states that it can be expected that users will use the top of a three or four foot stepladder in order to achieve the desired height for the intended task. Changes to make stepladders safer may include the extension of side rails along the steps to a height where they could be used as hand rails, and placement of a bar across the top of these rails to make the construction stronger. However, it is possible that users might then feel safe enough to carry out activities which they might otherwise not have done, such as overreaching.

This is an example of a popular theory known as 'risk compensation'. This idea, widely promulgated in the automotive safety arena by John Adams (1995), suggests that individuals will compensate for safer equipment and environments by undertaking riskier activities. In reality, this manifests itself as the using up of safety margins as performance benefits. A simple example would be that when consumers were provided with better braking in vehicles, they brake later and harder, rather utilising the benefit as an increased safety provision.

This theory goes on further to suggest that different individuals are predisposed to different levels of risk, and even that it might be possible to categorise groups of individuals on their risk taking attitude. This disposition can lead some individuals to behave in ways involving very high risk because they perceive that they are safe – for instance, if a leaning ladder is 'footed' the ladder user may be inclined to lean out much further. However, in controlled studies there has been little, if any, evidence of risk compensation occurring. (Thompson et al 2001)

In a large study by Hitchcock and Stroud (1988) on user behaviour with ladders, a telephone survey was carried out. This found that 60% of respondents claimed they carried out safety checks prior to using a ladder (e.g. ensuring the ladder was level, the fixings were secure, the ladder angled correctly). Yet, there were no significant differences between the number of accidents reported where safety checks had been made, and the number of accidents reported where safety checks had not been made. This suggests that fewer safety checks are made than claimed by the respondents, or that when safety checks are made they are not identifying the potential causes of accidents. In addition, 15 people aged between 16 and 85 were observed at home either performing or simulating a task that they normally performed whilst using their ladder. The authors admitted the potential problem of the 'Hawthorn Effect'; the positive consequences of benign supervision (Roethlisberger & William, 1939). Despite this, several observations of problems or unsafe use were made, for example:

- A ladder was used in front of a doorway (leaning ladder).
- People missed their step when climbing up and/or down (leaning and freestanding stepladders).
- Children were playing in the vicinity of the ladder in several cases, which could have resulted in a collision.
- Users 'over-reached' rather than move the ladders.
- Several people carried loose items up the ladder, sometimes with both hands.
- Several users compromised when faced with a choice of either insufficient space to lean the top of the ladder properly and fully against a surface or to ensure the ladder was on even ground.
- A ladder was used at a steeper angle, due to uneven ground.

- A participant descended the ladder facing outwards.
- A participant used an extension ladder with a broken rope mechanism.
- Very few safety checks were made on stepladders, with the exception of ensuring correct location of the platform at the top of the stepladders.
- Users stood on parts not designed for this, in order to facilitate a higher reach.
- No ladder accessories were used.

Generally the stepladders and short-length ladders were treated with far less respect than the longer, leaning ladders. Participants often attempted to use their ladders for tasks not suited to their ladder height or position.

Similarly, a study by Dufresne (1992) was designed to investigate the risk perceived by ladder users, in order to facilitate a better understanding of user's behaviour. This study was necessary because despite the manufacturers being aware of, and producing, ladders according to current standards, consumers frequently purchase a ladder that represents a safety hazard. This occurs because the specifications mainly address the requirements and test methods for ladder structure and do not consider the user's task requirements or their feelings of safety on the ladders. However, it has been shown that the perception of risk and the consequences of exposure affect human risk-taking behaviour. The results indicated that ladder users compromised between hazards perceived at different ladder inclinations, in order to select a preferred inclination. The recommended ladder inclination is 75°, whereas the mean preferred inclination was 65.2°; which is considerably lower than the recommendations. The author proposed design modifications which would reduce the risk of ladder slippage and increase sideways stability, thereby accommodating the user's preferred inclination, whilst presenting a safer ladder to use.

A study by Lawrence et al (1996) carried out in-depth interviews with 329 users. The majority of respondents (80%) said that they used stepladders parallel to the task, and over a quarter said they stood backwards on the treads; this was found to be more common in men than women (41% compared to 14%). The study also found that out of the 208 users who owned a one-way stepladder, 13% had used it as a leaning ladder (i.e. unfolded against a wall). Most respondents had never carried out any maintenance or repairs to their stepladder.

The testing programme permitting evaluation of stepladder safety was carried out in two parts:

- observation of typical use of stepladders by inexperienced users (n=40) permitted analysis of the frequency and types of unsafe behaviour and misuse exhibited;
- reconstruction of over-reaching, to produce a sideways fall, permitting observation and analysis of falls.

Two ladder types were used; one way and three way, 5 tread aluminium stepladders, as these were found to be the most popular amongst ladder users.

Participants were told that the aim of the experiment was to record biomechanical data on their movements. Stepladders were available only to help them reach the high parts of the task and they should only use it if and when they needed. Eight of the forty participants performed each task five times as an extended trial to see if the way they used the stepladders changed over a longer period.

The results showed:

- None of the participants read the instructions before use.
- No one checked for damage.
- No one assembled the three-way stepladder correctly the first time on their own.
- More males than females were prepared to go higher up the stepladder i.e. to the top platform on the one-way or to the fifth tread on the three-way stepladder.
- The majority of participants (80%) used both stepladders parallel to the tasks.
- Most participants seemed to over-reach, but this was difficult to assess accurately and to quantify.

On the whole, participants' behaviours did not alter over increased use; only one male participant started to reposition the stepladder during the trial. In addition, participants generally seemed to be more careful, due to a lack of familiarity with combination ladders.

During the simulation of falls testing, no obvious differences were found in stability between stepladders in terms of distance reached before the ladder became unstable. Furthermore, none of the stepladders buckled whether they conformed to BS 2037 Class 1 or Class 3 or EN 131 or not. The floor surface appeared to affect the manner in which tipping occurred. Following tipping, the stepladder righted itself in only one out of the 75 trials on a steel surface and in 22 out of 75 trials on a carpeted surface.

3.5 CONCLUSIONS

Ladders are made of a variety of materials: wood, steel, aluminium, magnesium and fibreglass. The most popular ladders are aluminium stepladders, due to their minimal weight and relative cheapness. Most homes (77%) own a stepladder however, this type of ladder is also involved in the highest number of accidents.

The shape of the rung has been shown to affect the stepladder user's behaviour, preventing over-reaching. Similarly, a stepladder with a steeper than average slope prompts the user to increase the speed of ascent. Thus, despite later research to the contrary, personal preferences in stepladder configuration may have some safety benefit. This is a subject, which warrants further research.

Research shows that leaning ladder angle plays a part in influencing the user's feelings of security and therefore affects behaviour. At steeper angles, the secure and correct placement of the hands becomes vitally important, as they enable the user to maintain stability throughout the task. Furthermore, those ladder users of a larger or smaller than average size are more likely to have an accident, which might indicate a need for customisation of equipment for such individuals. This would impact most upon employers, as they are required to provide 'suitable and safe' equipment.

It has been shown that users tend to use stepladders for whatever purposes they deem necessary, whether their ladder is the correct equipment for the task or not. Thus, the current display of warnings may be futile as it may be expected that users will not comply with the recommendations. An improved design accommodating known usage is suggested as an effective alternative to increased warnings. However, improvements to warnings may still be made.

4.0 INSTRUCTIONS AND WARNINGS

4.1 GUIDELINES AND STANDARDS ON WARNINGS AND THE SAFE USE OF PRODUCTS

The content and appearance of warnings has been given much attention. Research has shown that warnings and instructions may serve two purposes (Page, 2000). For a new user, these provide new information and for a more experienced user, they can serve to attract attention to a hazard.

In 1988, the DTI published instructions and safety information to help manufacturers with all aspects of writing instructions (Cooper and Page, 1988). In addition, they also published a document on safety instructions (CSU, 1998), which is intended to give manufacturers a better awareness and understanding of the consumer's needs of safety information.

Similarly, American (ANSI, 1990) guidelines state that manufacturers have a duty to warn ultimate users of dangers inherent in the product in terms of its:

- intended use; and
- reasonably foreseeable misuse.

The American Standards, ANSI Z535.1, 2, 3, 4 and 5 (1991) are useful on the development of warnings. The most relevant ones give useful advice on signs and labelling.

There are various other standards providing advice on instructions to be included on labels, as well as separate instruction leaflets guides (BS 4884: 1992; BS 4899: 1991; ISO Guide 37 1990).

The most useful of the current Standards available to manufacturers is ANSI Z535.4 1991 Product safety signs and labels. This Standard contains details of product safety signs and labels. The areas covered are outlined in Table 6 and serve as an indication of the issues that need to be addressed in the production of effective warnings and labelling.

Table 6
Product safety sign and labels in ANSI Z535.4 1991

Sign classification	Letter style and size
Hazard classification	Letter style
Signal word selection	Letter size
Multiple hazard identification	
Sign or label format	Sign and label placement
Panels	Location
Panel arrangement	Protection
Safety alert symbol	
Border	
Word message	
Pictorial	
Safety sign and label	Expected life and maintenance
Colours	Expected life
Standard colours	Maintenance
Signal word panels	Product user
Message panels	instructions
Pictorial panels	Replacement
Border	Installation procedures
Colour options	
Pictorials	
Recognition	
Testing for understandability	

4.2 WHY WARNINGS FAIL

4.2.1 Risk and Hazard Perception

Young et al (1990) reported that many research papers have noted that terms such as: hazard, risk and danger are all interchangeable to the layperson. However, there is also disagreement amongst experts as to what is meant by risk, although at the root of most definitions is the possibility of loss. This has three essential elements:

1. the loss itself;
2. the significance of these losses;
3. the uncertainty associated with the losses.

These factors are entirely subjective. Thus uncertainty has been suggested as a contributor to the overall risk of any situation (Yates 1992). When analysing risk, experts consider the likelihood of loss to be the most important measure. However, lay people are far more likely to consider the severity of loss or injury.

Karnes et al (1986) suggested that this was because the likelihood of injury or loss in most domestic settings is too low for most people to contemplate and so potential severity is far easier and more relevant. For the lay person estimation of high severity, low risk events is very poor.

Page (2000) suggests that the presumption that most people will avoid risk seems to be a reasonable one. However, this is not universally true and some people are indifferent to risk, whilst others will seek out risk. The author describes such people as 'thrill-seeking'. Thus, the personality and the situation influence the individual behaviour and risk-taking. Different levels of risk perception are described for different circumstances. People who are high-sensation seekers have also been found to tend towards dependencies on addictive substances, such as alcohol and drugs. Research by the British Medical Association (1987) showed that some consumers persisted in potentially harmful activities even when they were well aware of the consequences.

Page (2000) reports that people are more willing to accept voluntary risks than involuntary ones; it being common for people to dismiss risks on the basis of 'it won't happen to me'. This situation is especially likely if the risks are familiar and under their personal control.

Yates (1992) found that judgements on the levels of risk associated with a situation or actions were made on the basis of the relative frequency of the loss and subjective reasoning on cause and effect.

Many experiments have also shown (Karnes et al, 1986) that benign experience with a product or situation may produce some lessening of the perception of risk. This leads to a situation where those people with experience of a product or situation may judge the risks to be lower than those with less experience of a product do.

The perception of risk therefore varies both with the individual, and with their level of expertise in the area of risk assessment. Furthermore, some individuals actively seek out risk, rather than avoiding it. It has also been found that where a product or situation is familiar, the perception of risk is likely to be lessened.

4.2.2 Compliance With Warnings

Lehto and Miller (1986) described warnings as stimuli that alert people to hazardous conditions. However, little research has been addressed directly to the effects of warnings on decision-making (Stewart and Martin, 1994).

Page (2000) reports that people are habituated not to respond to unimportant stimuli, and many warnings are neglected not because of a conscious decision but due to habit.

It has also been shown that people are more likely to comply with a warning message in conditions of low cost and when they see another person complying (Wogalter et al 1989). In addition, warnings or instructions that reinforce beliefs about the consumer's ability to control accidents may be useful. The context in which the warnings are encountered, and the nature of the message itself, affect the quality and credibility of the message. (Handmer and Penning-Rowsell, 1990).

Other research by Robinson (1986) and Strawbridge (1986) on the design of instruction manuals and warnings indicated that there is a steady decline in the number of subjects who first noticed, then read and finally followed a warning.

When critical information was embedded within the rest of the instructions, compliance with the warning was significantly reduced. Although highlighting of warnings increased the numbers who read them, some people were able to fully recall warnings yet failed to carry them out. The placing of warnings within a specifically dedicated section dramatically increased the numbers who read, recalled, and complied with warnings.

In work on the general public's compliance with warnings and instructions, Leonard et al (1986) advocated the use of 'signal' words in an attempt to improve the levels of compliance. These are as follows:

- DANGER - an imminently hazardous situation which, if not avoided will result in death or serious injury;
- WARNING - a potentially hazardous situation which if not avoided could result in death or serious injury;
- CAUTION - a potentially hazardous situation which if not avoided may result in minor or moderate injury.

Frantz (1999) indicated in a recent paper, that excessively comprehensive lists of warnings were not to be recommended. Pictograms are often suggested as being a good resolution to the issues of warnings but research by Page (2000) found that they are poorly understood, and that their development and testing is frequently not undertaken due to expense. Therefore, providing warnings about all risks associated with a particular product is an incorrect approach.

The provision of warnings requires consideration of the potential impact, both positive and negative, of adding a particular warning to a product or manual. Furthermore, this consideration should not be limited to the potential warning at issue, but should also extend to the likely impact that such a proposed warning might have on the perception of, and response to, other warnings on the product and to warnings in general.

4.3 DEVELOPMENT OF EFFECTIVE WARNINGS

McGuire (1988) made the following recommendations to manufacturers, in order to establish the level of care exercised in preparing its product-use instructions. These were as follows:

- ensure that the instructional material is reviewed by several knowledgeable and responsible people and the final version is not signed off by the technical writer alone;
- carry out crucial testing of the material with consumers before wide scale market introduction of the product;
- document how the instructions were tested, what the tests showed and how they acted on the findings of such tests;
- ensure that warnings about misuse, abuse and inherent dangers are spelled out and their consequences described.

The ANSI test ANSI Z535.4 : 1991 for symbols requires the following:

- an appropriate test group of at least 50 people who are representative of the final users of the product
- score results based on:
 - correct responses
 - wrong responses
 - critical confusions (opposite to the correct response)
 - no response
- an acceptance level of:
 - more than 85% correct responses
 - less than 5% critical confusions
 - modification and re-testing of unsatisfactory symbols until a satisfactory one is found

However, this would be expensive to test, but possibly warranted due to the high numbers of ladder fall accidents.

There is also an ISO Standard, ISO 9186: 1989 for the development of public information symbols but this only requires a 66% rate of certain or likely understanding of the symbol with no requirement for assessing critical confusions. This would also be expensive to test.

Testing may be expensive but considering the requirement on manufacturers to take reasonably practicable steps to make their products safe, as well as the potentially serious consequences of ladder fall accidents, it may be recommended.

4.4 LABELLING ON LADDERS

Interviews carried out during a study by Lawrence et al (1996) revealed that the majority of stepladders purchased, conformed to Class 3 rating, with Class 1 stepladders being less common and more expensive. The volume and variety of sales was found to be concentrated through the large DIY multiples. There was also a lack of on-product information with respect to explanations of duty rating, maintenance, storage and inspection for specific damage and wear.

Whilst nearly all stepladders were found to have permanent labelling on safe use, few users were aware of it and recall of the messages was poor.

Lawrence et al. (1996) concluded that despite obvious safety labelling and warnings, these often remained unread. There was a definite need to raise awareness of these safety messages. They suggested that information be provided on:

- Limiting over-reaching.
- Use of stepladder facing the task.
- Use of stepladder on firm and level ground.
- Duty rating system used in British Standards.
- Advice on selection of stepladders.
- Advice on assembly of combination ladders.
- Suitability of stepladders for specific jobs.

Lawrence et al 1996 expressed concern that EN 131 does not have any requirement for safety labelling. It was suggested that this is reviewed and stepladders conforming to the Standard should be labelled. It was also suggested that a review of the Standards is carried out, to justify current test loads and methods used and the inclusion of performance and fatigue-testing methods. This is now in hand, as, there is currently a mandate from the European Committee for Standardisation (CEN) to review and evaluate stepladder standards.

The outcome of the study by Lawrence et al. (1996) was a DTI publicity leaflet, entitled 'Choosing a stepladder'.

This leaflet covers the following areas:

- Explanation of Standards and rating system.
- Checking stepladder for damage.
- Appropriate footwear.
- Positioning the ladder – away from overhead hazards, firm & level base, stepladder locked in position, and front on to the task.
- Behaviour whilst on the ladder – keeping a secure grip, never more than one person, no loose tools, both feet on step, never over-reach.
- Advice on storage.

This leaflet is supplied with all new ladders, but consumer response has not been measured.

5.0 COMPARISON OF EUROPEAN, NATIONAL AND INTERNATIONAL STANDARDS

A search was carried out of existing relevant standards relating to stepladders. The standards were taken from the UK, Europe, America, Canada and Australia, as these countries all have populations with comparable characteristics. Initially EN 131 : 1993 and BS 2037 : 1994 are reviewed here and a comparison made. EN 131 is currently under review by Committee B/512.

Subsequently, these are compared with other international Standards. The aim was to discover which contained requirements, or test methods, more stringent than BS EN 131. All standards reviewed are listed in Table 7. Those national standards identical to BS EN 131 were not reviewed. These relate to countries which have adopted EN 131. A list of these can be found in Table 8.

BS 1129: 1990 : Portable timber ladders, steps trestles and lightweight stagings is also not reviewed, as the scope is similar to BS 2037 except for the materials used. It also differs from BS 2037 only in the dimensions of the platform and the depth of step, and in that compliance only depends upon the quality and type of woods used. There are no design verification tests.

Table 7
This contains a list of all the standards reviewed

Standard	Title	Country
EN 131 Part 1 1993 -	Terms	European
EN 131 Part 2 1993 -	Specification	European
BS1129 : 1990	Portable timber ladders, steps trestles and lightweight stagings	UK
BS2037 : 1994	Portable aluminium ladders, steps trestles and light weight stagings	UK
EATS13/1 : 1987	Portable glass fibre ladders and steps, Technical specification	UK
AS 1657 : 1992	Platforms, walkways and ladders for personnel	Australian
UL 112 : 1998	Portable wood ladders (Underwriters independent Standard)	US
UL 184 : 1997	Portable metal ladders (Underwriters independent Standard)	US
ANSI A14.1/2000	Ladders- Wood safety requirements	US
ANSI A14.2/2000	Portable metal ladders	US
AS/NZS 1892.1: 1996	Portable ladders (metal)	Australia and New Zealand
AS/1892.2-92	Portable ladders (timber)	Australia
ANSI A14.5 : 2000	Ladders - portable reinforced plastic - safety requirements	US
CSA Z11 M81	Portable ladders (rp: 03/83, 12/87)	Canada

5.1 A REVIEW OF BS EN 131 : LADDERS

BS EN 131 : 1993 : Parts 1 and 2 were prepared under the direction of the Technical Sector Board for Building and Civil Engineering, and were published by the European Committee for Standardisation (CEN). The committee comprises the national standards organisations of the following countries: Austria, Belgium, Denmark, Finland, France, Germany, Greece, Iceland, Ireland, Italy, Luxembourg, Netherlands, Norway, Portugal, Spain, Sweden, Switzerland and the United Kingdom. The CEN members are bound to comply with internal Regulations, which stipulate that the European Standard must be given the status of a national standard, without any alteration. The Standard comprises two elemental parts:

Part 1 : Specification for terms, types and functional sizes

Part 2 : Specification for requirements, testing and marking

BS EN 131 supersedes Class 2 of BS 1129 : 1990 and Class 2 of BS 2037 : 1990. It covers types of portable ladders covered by BS 1129 and BS 2037. In addition, it is also concerned with sectional, mobile and combination ladders, not previously covered in British Standards. It does not cover ladders for special professional use.

BS EN 131 : Part 1 gives definitions and general terms, dimensions and general design characteristics, as well as technical requirements of safety for the materials used. Unlike BS 2037, there is only one duty rating of 110kg, with a maximum loading of 150kg for ladders to conform to this Standard. However, there is work currently in progress to separate this standard into two, performance-based, classes.

There are several types of ladder covered by BS EN 131, including:

- Mobile ladders.
- Rung ladders.
- Push-up extending ladders.
- Sectional ladders.
- Combination ladders.
- Leaning stepladders.

Table 8
European member state implementations of BS EN 131 Part 1 and BS EN 131 Part 2

Standard	Title	Country
UNI EN 131 Part 1: 1994	Ladders - specification for terms, types, functional sizes	Italy
UNI EN 131 Part 2 : 1994	Ladders - specification for requirements, testing, marking	Italy
DIN EN 131 Part 1 1993	Ladders, terms, types, functional sizes	Germany
DIN EN 131 Part 2: 1993	Ladders; requirements, testing, marking	Germany
NBN EN 131-1: 1993	Echelles - terminologie, types, dimensions fonctionnelles	Belgium
NBN EN 131-2: 1993	Echelles - exigences, essais, marquage	Belgium
NF EN 131-1: 1993	Echelles - terminologie, types, dimensions fonctionnelles	France
NF EN 131-2: 1993	Echelles - exigences, essais, marquage	France

This report is only concerned with one type of ladder in BS EN 131; ladders referred to as ‘standing step ladder’. This is defined as a “two legged, self-supporting stepladder, unilaterally or bilaterally ascendable; with or without platform”. A platform is regarded as a step. The various types of stepladder displayed in BS EN 131 : Part 1 are depicted in Figure 9.



A. Platform ladder



B. Standing rung ladder

•
•



C. Standing rung ladder with splayed stiles



D. Standing rung ladder with parallel stiles and stabilisers

Figure 9
Four types of step ladder depicted in BS EN 131 Part 1 : 1993

5.1.1 Section 1: Functional Sizes

- **Steps** should not be less than 80 mm from front to back.
- **Platform** should have a minimum depth and width of 250 mm.
- **Distance between rungs** on a standing rung ladder must be between 250 mm and 300 mm. Distance between rungs on a standing stepladder with platform is greater, at between 230 and 300 mm.
- **BS EN 131 : Part 2** gives specifications for materials, functional size requirements, testing and marking.

5.1.2 Section 2: Materials

- **Aluminium alloy and steel** used must conform to given standards, and be of a minimum thickness of 1.2 mm or 1 mm respectively. The minimum thickness given does not include metal fixings and washers.
- **Wood** is a complex material for purposes of safe construction. There is a detailed section containing specifications of species, general condition, knots, pitch pockets, moisture content, use of laminated wood and adhesives.
- **A design section** specifies the avoidance of shearing points and the need for durability of the connections. Furthermore, specifications and standards are given for the fixings used.
- **Surface finish** should not be a potential cause of injury and all materials should be coated to prevent corrosion or atmospheric damage. Hinges must be durable and secure against unintentional opening and there must be opening restraints to prevent the ladder from opening beyond the normal use configuration.
- **Rungs and steps** (the platform is regarded as a step) must have an anti-skid surface and be durably and firmly connected to the stiles. Various examples of joint construction are given, as well as the minimum thickness of steps, which should be not less than 18mm.
- **The platform** must have an anti-skid surface and must lift up as the ladder is folded. Furthermore, it must remain in position when the ladder is in use.
- **Anti-skid** bottom ends (feet) of ladders may consist of a variety of devices, such as safety shoes or spikes, amongst others. However, wooden stiles are considered to be anti-skid.

5.1.3 Section: Testing

A number of reproducible tests are described in order that manufacturers can test the conformity of their product with the requirements of the Standard.

- **Strength Test**

This test is carried out on the folded ladder, laid flat as in Figure 10 so that the stiles and rails are all in a horizontal position.

A pre-load of 500 N is applied for one minute. The test load of 1000 N is applied for one minute. After removal of the load, measurements are taken. The permanent deformation f of the ladder must not exceed 0.1% of the distance l between the supports.

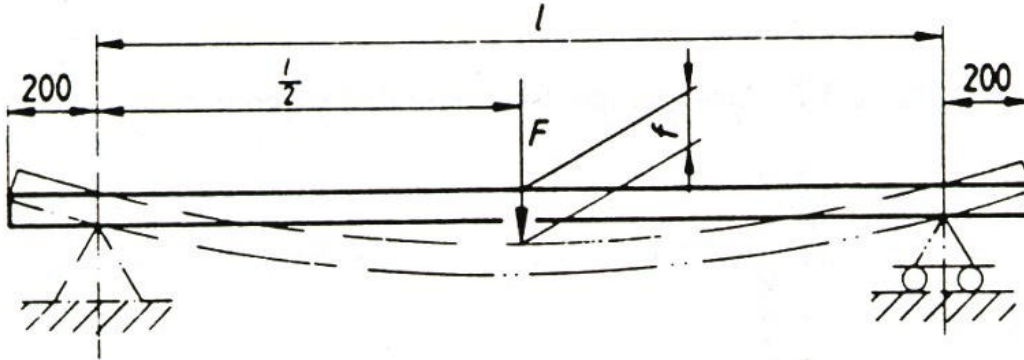

Figure 10
Ladder position for the strength and bending tests

- **Bending Test**

This is carried out with the ladder in the horizontal position, as in Figure 10. A pre-load of 100 N is applied for one minute. Thereafter, a test load of 750 N is applied for at least one minute. The maximum permissible deflection is a function of the distance between the supports (Section 4.3, BS EN 131 : Part 2)

- **Lateral Deflection Test**

The ladder is placed in a lateral position, as in Figure 11. A pre-load of 100 N is applied for one minute. A test load of 250 N is then applied to the middle of the lower stile for one minute. The maximum permissible deflection is 5% of the distance between the stiles.

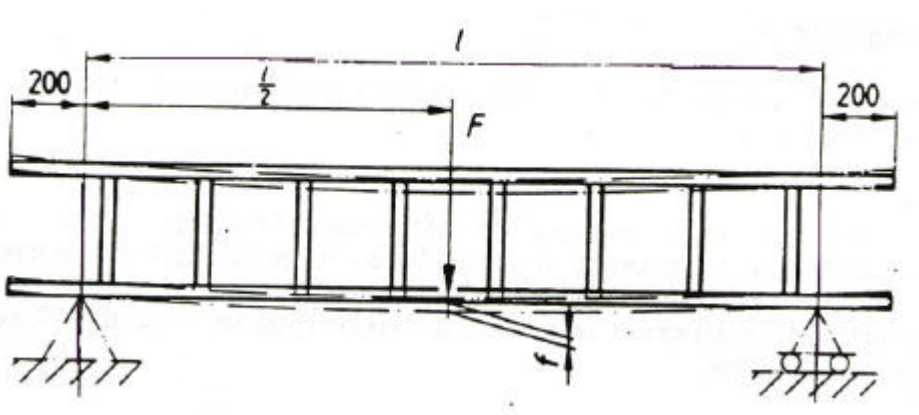

Figure 11
Ladder position during lateral deflection test

- **Bottom Stile Ends Test**

The ladder is placed on a support with the stiles in a horizontal position, as in Figure 12. The ladder is fixed to the support up to the level of the lowest step. A load of 50mm wide is placed 25mm from the end of the stile, inclusive of the foot.

A vertical force of 900 N is applied across the middle of the load for one minute. The permanent deflection must not exceed 2mm. Cracks or fractures are not permissible. The test is performed at all supporting legs.

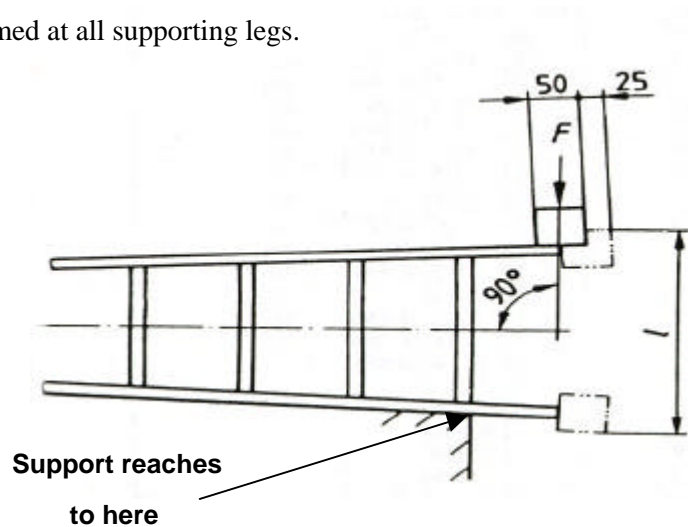

Figure 12
Bottom stile ends test

- **Bending test for steps and platforms**

A pre-load of 200 N is applied for one minute. A test load F of 2600 N is applied to the ladder in the normal position of use across the full depth of the step, as shown in Figure 13. This is applied for one minute. The maximum permanent deformation, after removal of the test load is 0.5% of the inner width of the tested step.

- **Torsion test of steps**

This is tested with the ladder in the normal position of use, as shown in Figure 14, torque M of 50 Nm is applied to the centre of the step. This is applied alternately, 10 times clockwise and 10 times anticlockwise. There must be no relative movement between step and stile. The maximum permanent deformation is $\pm 1^\circ$.

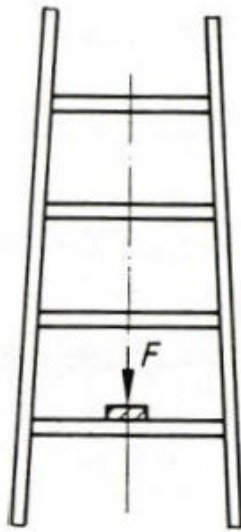

Figure 13
Bending Test of Steps and Platform

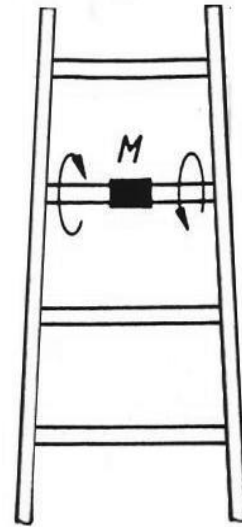

Figure 14
Torsion test of steps

- **Test of opening restraint**

With the ladder placed in a working position, as in Figure 15, each leg is placed on a platform with rollers, to enable the ladder feet to move freely under loading.

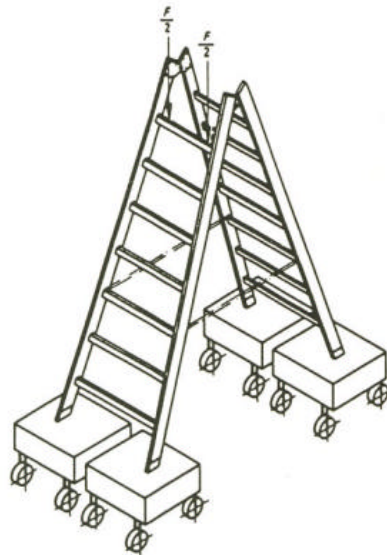

Figure 15
Test of opening restraint

The test load of 2600 N must be divided into two loads, which are to be applied to the uppermost step, as close as possible to the stiles for bilaterally ascendable ladders. For platform stepladders, the load is to be applied to the front end of the platform, and then repeated at the rear end. The load is to be applied for one minute.

The Standard recommends that there be no visible permanent deformation or cracks, unless this does not impair the ladder's fitness for use. The latter is obviously a somewhat subjective assessment.

5.1.4 Marking

Only ladders complying with this Standard may be marked EN 131. The ladder must also show the product name, manufacturer and/or supplier, year and month of manufacture and/or serial number, type of ladder and the maximum permissible load.

5.2 A REVIEW OF BS 2037 : 1994

This Standard supersedes BS 2037 : 1990, Portable aluminium ladders, steps trestles and light weight stagings. It covers three classifications of ladder:

- **Class 1 – Industrial** – heavy duty, high frequency use and onerous conditions of use, carriage and storage. Suitable for industrial purposes. The maximum expected combined weight of user and tools is 130 kg.
- **Class 2 – Light trades** – low frequency use and less onerous conditions of use, carriage and storage. However, this class has been withdrawn and is now covered by BS EN 131.
- **Class 3 – Domestic** – light use only, maximum duty rating load is 95 kg.

There are several types of ladder covered by BS 2037 : 1994, including:

- Single section ladders, including shelf ladders.
- Extending ladders.
- Standing stepladders, swing back steps, folding steps and ladder backed steps.
- Folding trestles.
- Lightweight stagings.
- Combination ladders.

For the purposes of this review, only the Sections relevant to step ladders will be considered.

This Standard also contains guidance on the following areas:

- Care and use of ladders; handling, storage and transport.
- Maintenance.
- Inspection.
- Painting.
- Cleanliness.
- Electrical hazards.
- Fixing of the ladder.

There is also a section on general use of ladders. Within this, users are advised that the ladder is not designed for ‘side loading’ and that ‘such abuse should be avoided’. Furthermore, ladders should be kept close to the work and ‘overreaching’ should be avoided. It is also advised not to stand on the top tread and that the user ‘should face the ladder’ when ascending and descending.

5.2.1 Section 1: Materials

- **Specifications** are given for the component materials of various parts, including: guide brackets and fixed and latching hooks, hinges and decking.
- **Feet of stiles** and capping for upper ends of treads shall be plastic, rubber or timber.

5.2.2 Tolerances on Functional Sizes

- **Spacing** of steps and treads shall not vary by more than ± 2.0 mm. Ladders must conform to the specification in the Standard for length, with an allowable tolerance of ± 25 mm.

5.2.3 Marking

This must be clear and durable. There are guidelines for testing of durability. Tie-on labels are not to be used. The following information must be given:

- Manufacturer.
- Number and date of British Standard BS 2037 : 1994.
- Class and duty rating.
- Never use damaged equipment.
- Ensure firm and level base.
- Check for hazards at top.
- Folding trestles.
- Lightweight stagings.
- Avoid electrical hazards.
- Avoid overreaching.
- Keep a secure grip.
- Never stand on top rail of stepladder or the top of swing back steps.

5.2.4 Section 2: Functional Sizes

- **Distance between stiles and specification for ladder feet.**

The minimum width for the top stile of stepladders is 250 mm. This increases by 12 mm per tread for Classes 1 and 2 and by 22 mm for Class 3. The bottom ends or feet must be fitted with non-slip feet, which should be securely fixed but removable.

- **Size, number and spacing of treads**

These should be not less than 75mm wide from front to back, with a textured surface. Steps can have any number of treads; up to 16 treads for Class 1, 10 treads for Class 2 and 9 treads for Class 3.

The spacing must be uniform at between 225 and 300 mm, whereas the distance from the bottom of the feet to the top of the first tread must be between 125 and 300 mm.

- **Platform**

This should have a minimum depth and width of 250 mm.

- **Top**

This must have a textured surface, and be not less than 100 mm from front to back.

- **Opening restraint**

There must be a locking device between the front and back stile, in order to limit the opening of the steps, and to ensure that the inclination of the back is between 72° and 80°.

5.2.5 Testing

Several design verification tests are included.

- **Rigidity**

A wheel is attached to one of the back stiles, as in Figure 16, to allow the leg to move freely. The steps should be placed in an open position and a specific pre-load and load are applied to the tread below the platform for one minute.

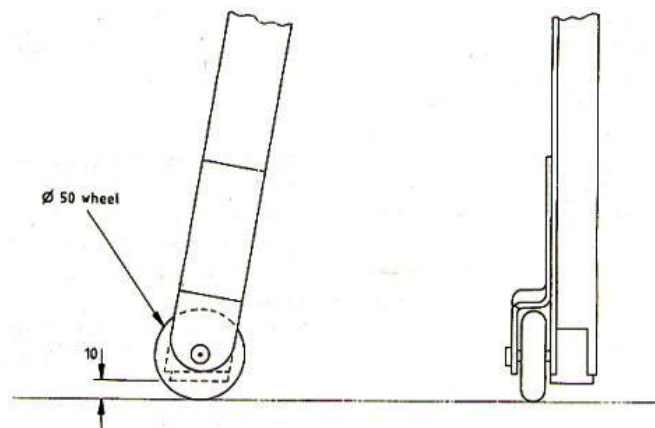

Figure 16
Method of attaching wheel to back stile of stepladder to allow free movement

The class of ladder determines the weight of the load. The loads are given in Table 9. When tested, the steps must show no permanent deformation or damage. A spread of 8 mm between the front and rear stiles is acceptable.

Table 9
Test loads for rigidity testing of stepladders

Duty rating	Pre-load (kg)	Load (kg)
Class 1	95	130
Class 2	90	120
Class 3	85	110

- **Test for treads**

This is carried out with the ladder in a working position. A load, as given in Table 10, is applied to a ladder-tread.

Table 10
Test loads for treads

Duty rating	Test load (kg)
Class 1	225
Class 2	200
Class 3	180

This is done for one minute each, in two separate positions, at the centre and close to one end. The tread must support the load, and there must be no permanent deformation greater than 1.0 mm.

- **Deflection under load**

The ladder is supported, as shown in Figure 17. The distance between the supports is the test span (L) and must be measured. A pre-load is applied vertically to the centre of the ladder for a duration of 30 seconds. This must be distributed over 50 mm, so that the stiles are loaded equally.

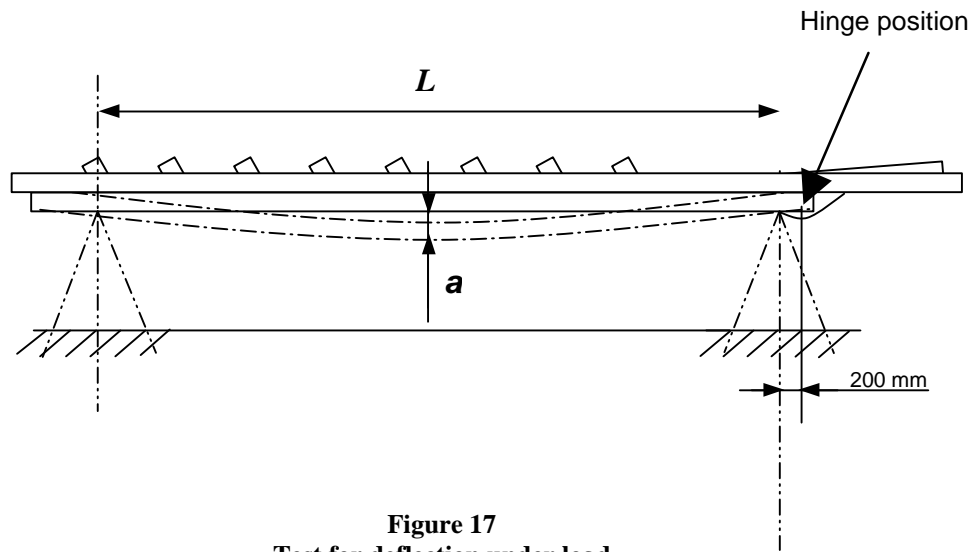

Figure 17
Test for deflection under load

This load is removed, a datum point is established. A test load is then applied to the centre of one of the stiles over a 50 mm area, according to the class of ladder. The test load is applied for one minute. See Table 11 for the required pre-loads and loads.

Table 11
Pre-loads and loads for deflection test

Duty rating	Pre-load (kg)	Test load (kg)
Class 1	55	75
Class 2	50	65
Class 3	40	55

The vertical deflection (**a**) at the centre of the test span must be measured not less than 30 seconds after the test load has been removed. The equation below gives the maximum allowable deflection (Max **a**) for ladders less than 12 m in length.

$$\text{Max } a \leq \frac{L}{37.2}$$

After removal of the test load, there should be no permanent damage and the permanent deflection must not exceed 1.0 mm per metre of test span.

- **Strength test**

The ladder is supported horizontally under the stiles as shown in Figure 17: Test for deflection under load. The distance between the supports is the test span (L) and must be measured. A pre-load is applied vertically to the centre of the ladder for one minute. This must be distributed over 50 mm, so that the stiles are loaded equally.

Once this is removed, a datum point is established. A test load is then applied to the centre of one of the stiles over a 50 mm area, according to the class of ladder. See Table 12 for the required pre-loads and loads. These are higher than in the test for ‘deflection under load’. The test load is applied for one minute.

Table 12
Pre-loads and loads for strength test

Duty rating	Pre-load (kg)	Test load (kg)
Class 1	95	130
Class 2	80	110
Class 3	70	95

The vertical deflection (a) at the centre of the test span must be measured not less than 30 seconds after the test load has been removed. The equation below gives the maximum allowable deflection (Max a) for ladders less than 12 m in length.

$$\text{Max } a \leq \frac{L}{37.2}$$

After removal of the test load, there should be no permanent damage and the permanent deflection must not exceed 1.0 mm per metre of test span.

- **Sideways bending**

The ladder is placed on its side, as shown in Figure 18. The top of the ladder is supported 200 mm in from the hinge point, as in Figure 17. Datum is determined after a pre-load of 15 kg is applied for one minute. A test load is then applied at the centre of the span, over a distance of 50 mm. The class of the ladder, as shown in Table 13, determines the weight of the test load. The vertical deflection is then measured before the test load is removed.

The residual deflection is measured between the centre of the supports, one minute after removal of the test load. The deflection must not exceed $0.0033 L$. The residual deflection must not exceed 1 mm per metre.

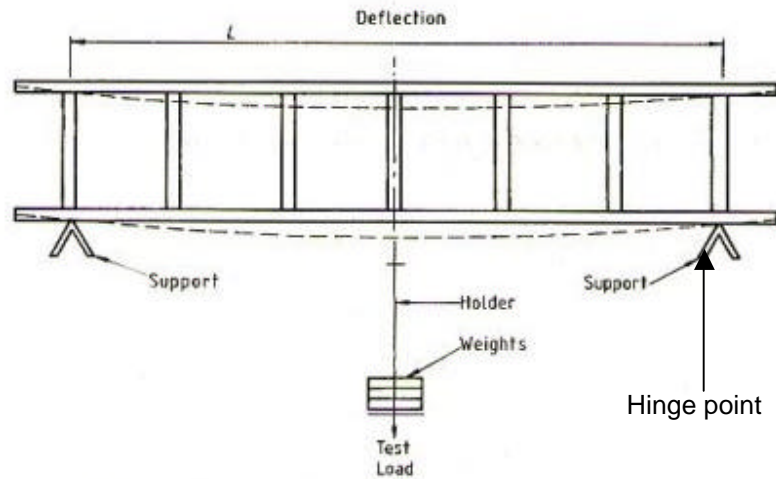

Figure 18
Sideways bending test

Table 13
Pre-loads and test loads for sideways bending test

Duty rating	Pre-load (kg)	Test load (kg)
Class 1	15	27
Class 2	15	25
Class 3	15	23

- **Cantilever bending**

The stepladder is placed on its side, as shown in Figure 19; unsupported from the bottom of the stile to the centre point of the bottom step. After a datum point is established on the end of the stile, a test load is applied, as in Table 14.

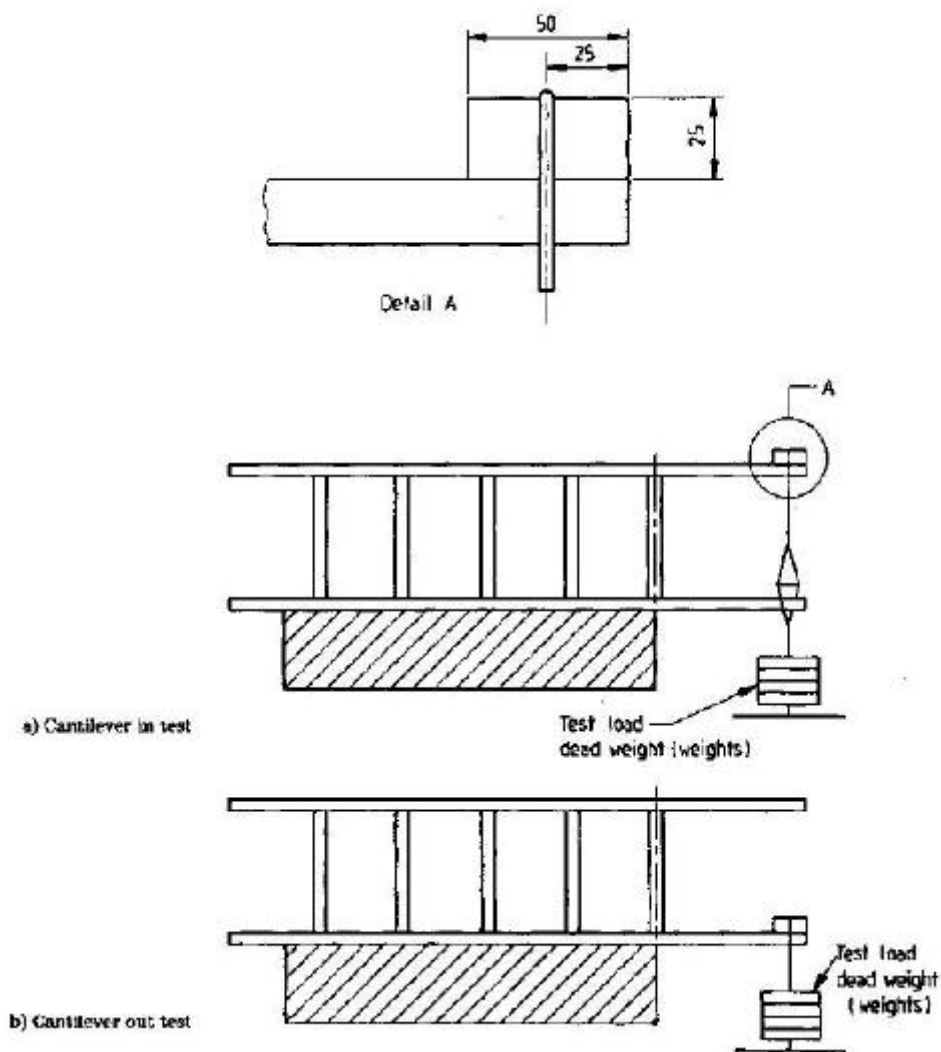

Figure 19
Cantilever bending test

Table 14
Test loads for cantilever bending

Duty rating	Test load (kg)
Class 1	125
Class 2	120
Class 3	90

The load is applied for a minimum of one minute. Once the load is removed the residual deflection must be measured within one minute of removal of the load. This process is then repeated for the lower stile. The permanent deformation of each stile must not exceed 6 mm.

5.3 COMPARISON OF EN 131 : 1993 AND BS 2037 : 1994

There are 18 countries in the CEN/TC93, all of which are required to adopt EN 131 without any alteration. However, only five countries so far have adopted EN 131 as their own national Standard.

EN 131 was intended to replace Class 2 of BS 1129 and BS 2037, which applies to ladders for 'light trade' purposes. Yet, this Standard has a higher maximum expected combined weight of user and tools (150kg), than the maximum loading requirement placed on Class 1 ladders (130 kg) for industrial purposes. There are, however, plans to separate EN 131 into two, performance related, classes.

5.3.1 Functional Sizes

The minimum distance between stiles in BS 2037 is 250 mm, which is narrower than EN 131, which stipulates a minimum width of 280 mm. There is also a greater range of distances between rungs in the British Standard (225 to 300mm), whereas the minimum distance in EN 131 is 250 mm. There is, however, no apparent size limit on step ladders in EN 131, whereas BS 2037 limits Class 1 ladders to 16 treads, Class 2 ladders to 10 treads and Class 3 ladders to 9 treads. EN 131 requires treads to have a greater minimum width than the British Standards.

5.3.2 Labelling

EN 131 does not currently have any requirement for safety labelling; only requiring ladders to display information on: product identification, permissible loads and angle of use. The British Standard requires instructions to be given, such as 'check for hazards at top' and 'avoid electrical hazards'. There are currently, however, plans to include safety labelling as pictograms or text, which must be attached to all ladders. This will also cover the maximum permissible load and the number of people permitted on the ladder.

5.3.3 Care and Use of Ladders

The British Standard has a section giving guidance and recommendations on the care and use of ladders, however, there is no such guidance in the European Standard. Again, this is an area which is under review. Thus, there are currently plans to include sections on ladder inspection, ladder positioning and erection, use of the ladder, repair, maintenance and storage. It is also intended to include areas to be considered for risk assessment.

5.3.4 Performance Tests

EN 131 uses heavier test loads for the tread and platform test (See Appendix 1 for Table of Standards Comparison) and has a more stringent criterion for success for the bottom stile ends test than BS EN 131. However, both Standards use similar test techniques and neither contains any stability or fatigue tests. The test loads are also currently under review, with a view to possibly making the requirements more stringent.

5.4 COMPARISON OF EN 131 WITH OTHER NATIONAL STANDARDS

The requirements within EN131 were compared with Standards from other countries.

5.4.1 European Standards

Italy, Belgium, France and Germany have all adopted EN 131 as their national standard. Thus, a comparison is unnecessary.

5.4.2 USA Standards

The ANSI and UL Regulations are very similar, although ANSI provides slightly more detail. The comparable design specifications are identical except for a slightly smaller distance requirement between stiles in UL 112. A comparison of ANSI with EN 131 showed that the USA places many requirements on manufacturers with respect to safety labelling. In addition, functional size requirements are somewhat larger for the 'distance between treads' and 'platform size' specifications. Interestingly, the minimum thickness of treads is less than that specified in EN 131, despite the test loads in ANSI and UL tests being one third heavier. ANSI contains mostly design verification tests.

5.4.3 Australia and New Zealand Standard

A comparison of AS/NZS 1892.1 with EN 131 reveals some requirements and test methods to be similar in approach, yet, there are some differences in the dimensional requirements. The AS/NZS Standard allows a wider range in the 'distance between treads' measurement, yet the minimum thickness of the treads themselves is less than that specified in EN 131. The AS/NZS Standard was similar to EN 131 in that it was the only other standard having a requirement for a 'lateral deflection test of the supporting leg' (of the ladder). However, a major difference between the Standards is that AS/NZS requires much heavier test loads to be used. In the latter test, for example, the test load required is almost four times that of the EN Standard.

Similarly, the test load for the step torsion test involved torques of double that required in the European Standard. The AS/NZS Standard also has some additional tests that are not covered by EN 131, such as the stability and walking tests (see Appendix 1). The AS/NZS Standard has more safety labelling than EN 131 but less than all the ANSI, UL and BS Standards.

5.5 CONCLUSION

Despite a requirement for EU Member States to adopt EN 131, only five countries have adopted it as their national standard. From the comparison with other national standards in the USA, Australia, and New Zealand, there are both similarities as well as major differences. EN 131 is the only national standard which lacks stability or performance-related tests. Furthermore, the test loads are much higher in other comparable standards. This implies that the test loads and the criteria applied for their selection may need to be re-evaluated. In addition, all other national standards have some requirement for safety labelling, with the exception of EN 131. However, as has been indicated, there are plans to include these elements into a revised standard.

6.0 REGULATIONS APPLICABLE TO LADDERS

A review of Health and Safety Regulations was carried out to discover which were applicable to the use of stepladders. The following includes the relevant clauses from the cited Regulations.

6.1 PROVISION AND USE OF WORK EQUIPMENT REGULATIONS 1998 (PUWER 98)

The Health and Safety Executive (HSE) produced this document after consultation with industry. These Regulations apply to all workplaces and work situations where the Health and Safety at Work etc Act 1974 (HSW Act) applies and are intended to ensure that work equipment does not result in an accident, regardless of its age, condition, or origins. Ladders are covered under this guidance and are defined as work equipment.

6.1.1 Suitability (Regulation 4)

This regulation places a duty on employers to ensure that work equipment is suitable for the person and the task for which it is intended. This means the employer should ensure the equipment is used according to the manufacturer's instructions. Furthermore, employers should take into account the working conditions and the risks to the health and safety of the individual using the equipment.

6.1.2 Ergonomics (Regulation 4)

PUWER 98 recommends that employers should take into account the ergonomic risks. The equipment should take into account the size and shape of the individual and operators should not be expected to exert undue force or reach beyond their normal limitations.

6.1.3 Maintenance (Regulation 5)

An employer should make sure the work equipment provided is maintained to good working order and is in good repair. The frequency of maintenance should take into account the intensity and frequency of use, operating environment and potential risks to health and safety of equipment failure.

6.1.4 Risk Assessment and Inspection (Regulation 6)

Where a risk assessment has identified a significant risk to the individual from the work equipment, a suitable inspection must be made. Falls from ladders result in approximately 50 fatalities per year. Thus, ladders could be viewed as posing a significant risk.

6.1.5 Specific Risks (Regulation 7)

Where the use of the equipment involves a specific risk, every employer should ensure that use of the equipment is restricted to those individuals whose task it is to use it and that repairs are carried out by a specifically designated and trained person.

6.1.6 Information and Instruction (Regulation 8)

Employers shall ensure that all persons who use work equipment have health and safety information available and written instructions for the safe use of the equipment.

6.1.7 Training (Regulation 9)

Each employer must ensure that all persons using work equipment have received training on the health and safety issues and precautions to be taken.

6.1.8 Stability (Regulation 20)

Employers shall ensure that work equipment is stabilised. In the case of ladders, 'where the stability of the work equipment is not inherent in its design', or where it is mounted in a position where stability could be compromised, additional measures should be taken to ensure its stability. Ladders should also be at the correct angle and tied or footed.

6.2 THE MANAGEMENT OF HEALTH AND SAFETY AT WORK REGULATIONS 1999

This is the revised version of the 'Management of Health and Safety at Work Regulations 1992'. These Regulations require every employer and self employed person to make a suitable and sufficient assessment of the risks to workers or anyone else affected by their work. The hazards should be identified and preventive and protective measures undertaken to control the risks identified. Finally, periodic reviews should be carried out to ensure that the system remains effective.

6.3 THE WORKPLACE (HEALTH, SAFETY AND WELFARE) REGULATIONS (WHSW) 1992

These were drawn up after consultation with representatives from the Trades Union Congress, the Confederation of British Industry, local authorities and the HSE. These Regulations apply to a wide range of workplaces.

6.3.1 Falls (Regulation 13)

This covers falls or falling objects and states that practicable, suitable and effective measures should be taken to prevent any person falling a distance or being struck by a falling object likely to cause personal injury.

6.3.2 Ability to Clean Windows etc Safely (Regulation 16)

Windows and skylights in a workplace should be designed so that they may be cleaned safely. This may include windows, which pivot so that the outer surface is turned inwards or the provision of suitable conditions for the future cleaning of windows. This provision refers to access for ladders and requires a firm, level surface on which to place the ladders, and suitable points for fixing the ladder if they are over six metres in length. Furthermore, there should be suitable and suitably placed points for anchoring of a safety harness.

6.4 A GUIDE TO THE CONSTRUCTION (HEALTH, SAFETY AND WELFARE) REGULATIONS (CHSW) 1996

These are simplified construction Regulations, which also include new provisions arising from the implementation of an EC Directive on construction (92/57/EEC).

The CHSW Regulations explain the detailed ways of working in construction activities, and are aimed at protecting the health, safety and welfare of persons carrying out construction work, as well as giving protection to others who may be affected by the work. These Regulations apply to employers, employees and anyone doing construction work.

6.4.1 Safe Place of Work (Regulation 5)

Persons involved in construction have a general duty to ensure a safe place of work. This also applies to work at height and requires that 'reasonably practicable steps' be taken to provide for safety and the minimisation of risks to health. More than 50% of the fatal accidents in construction are the result of a fall. The Regulations aim to prevent falls from any height, but have specified certain steps to be taken for work over two metres high. Where the work cannot be carried out at ground level it is necessary to provide physical safeguards in order to prevent falls from occurring.

6.4.2 Precaution Against Falls (Regulations 6 and 7)

If this is not reasonably practicable, due to short task duration or task difficulty, it is advised to use personal suspension equipment such as rope access or boatswain's chairs.

If these are impractical for the reasons given above, equipment which will arrest falls must be considered such as a safety harness. Any specific equipment must be erected or installed under the supervision of a competent person.

6.4.3 Training and Inspection (Regulation 28, 29 and 30)

Construction activities must only be carried out by persons with relevant training or experience, or supervised by those with the appropriate levels of training or experience. Before any work at height is carried out, the place of work must be inspected by a competent person, who must be satisfied that the work can be completed safely.

6.5 ANNEX: AMENDING PROPOSAL OF DIRECTIVE 89/655/EEC CONCERNING THE MINIMUM SAFETY AND HEALTH REQUIREMENTS FOR THE USE OF WORK EQUIPMENT BY WORKERS AT WORK (SECOND INDIVIDUAL DIRECTIVE WITHIN THE MEANING OF ARTICLE 16 OF DIRECTIVE 89/391/EEC) Version 4.4

This Directive is intended to regulate safety on temporary work at height. The aim is to reduce the incidence and severity of injuries caused by falls from a height. It provides a hierarchy for the selection and minimum requirements for the use of access equipment for temporary work at height, as well as specific requirements for common forms of temporary access, such as ladders and scaffolding.

6.5.1 Regulation 4

Employers are required to select the most suitable and safest access equipment, based on their risk assessment. This selection must also take into account the frequency, the height and the duration of the task. Furthermore, they are required to put into place measures that will prevent or arrest falls from a height. Collective equipment (netting) should take precedence over personal protective equipment (lanyards). The presumption is made that ladders and rope access will only be used as workstations when the use of other, safer equipment (scaffolding) is not justified due to the low level of risk, the duration of the task, or other features of the site that the employer cannot alter.

6.5.2 Specific Provisions Regarding the Use of Ladders (Regulation 4.2)

Ladders must be positioned and secured to ensure stability during use. They must rest on a stable, immobile footing, such that the rungs are horizontal. The stiles must be secured by an anti-slip device.

Ladders must be used in such a way that workers can access a secure handhold or support at all times. Any load to be carried must not prevent the maintenance of a secure handhold.

6.5.3 National and International Regulations Applicable to Ladders and Stepladders

In October 2000, the Victorian Workcover Authority produced the following review of national and international regulations applicable to ladders and stepladders, as a part of larger survey on the causal factors implicated in accidents involving ladders.

United States

The *OSHA Regulations Part 1926 Safety and Health Regulations for Construction (Duty to have fall protection – 1926.501)* provide that employees working at 6 feet (1.8 m) or more above lower levels shall be protected by guardrail systems, safety net system, or personal fall arrest systems – except when the employer can demonstrate that it is infeasible or creates a greater hazard to use these systems, the employer shall develop and implement a fall protection plan which meets the requirements of the Regulations.

Ladders – 1926.1053(b) provides in great, prescriptive detail for the use of fixed and portable ladders. The Regulations does not establish a hierarchy of control; employers are permitted to select fall protection measures compatible with the type of work being undertaken. The sections dealing with ladders (1053 (a) and (b)) do not indicate that ladders are to be avoided if safer alternatives are practicable.

Canada

Part II of the Canadian Labour Code provides overarching legislation. Standards are framed within the terms of this legislation. The available information on use of ladders recommends that a safety harnesses be used in conjunction with ladders when working 3 m or more off the ground or when working with both hands.

The Ontario *Occupational Health and Safety Act, Construction Projects O. Reg. 213/91*, regulate ladders under Part II General Construction. These provisions prescribe requirements for the design, manufacture and maintenance of ladders. In respect to use, a ladder is required to be placed:

“so that its base is not less than one quarter, and not more than one third, of the length of the ladder from a point directly below the top of the ladder and at the same level as the base of the ladder if the base is not securely fastened”.

Ladders that are used as a regular means of access between levels of a structure.

- “(a) shall extend at the upper level at least 900 mm above the landing or floor;
- (b) shall have a clear space of 150 mm behind every rung;
- (c) shall be located so that an adequate landing surface free of obstacles is available at the top and bottom of ladder;
- (d) shall be secured at the top and bottom to prevent movement”.

Stepladders are specifically regulated as follows:

“When a stepladder is being used as a self-supporting unit, its legs shall be fully spread and its spreader shall be locked”.

“No worker shall stand on the top of, or the pail shelf of, a stepladder”.

In British Columbia, s.13.8 of the *Occupational Health and Safety Regulation* places a number of “use restrictions” on ladders:

“(1) A worker must not work from the top two rungs of a portable single or extension ladder or the top two steps of a step ladder unless permitted by the manufacturer.

(2) A ladder must not be used as a scaffold component, nor as a horizontal walkway, ramp or work platform support unless it is part of a premanufactured or engineered system.

(3) A worker may work from a portable ladder without fall protection provided that

- (a) the work is a light duty task of short duration at each location,
- (b) the worker’s centre of gravity is maintained between the ladder’s side rails,
- (c) the worker will generally have one hand available to hold onto the ladder or other support, and
- (d) the ladder is not positioned near an edge or floor opening that would significantly increase the potential fall distance”.

New Zealand

The Occupational Safety and Health Service of the Department of Labour, New Zealand has developed *Guidelines for the Prevention of Falls* (January 2000) to assist duty-holders in meeting the requirements of the *Health and Safety in Employment Act 1992* and *Regulations 1995*.

The guidelines are “primarily aimed at the construction industry, in relation to the design, building, maintenance and demolition of structures”, but they also have application “to a wide range of work situations where workers are placed in a position from which falls are possible”. They apply to work carried out from 3 m or more in height. However, “where there is a possibility of serious harm from a fall of less than 3 m, fall protection is still needed”.

A generic hierarchy of control is adopted: elimination, isolation or minimisation (the least preferred option). Control measures to prevent falls are not set out under this hierarchy, so it is not possible to discern whether ladders are included in, or excluded from, the hierarchy. Guidelines for ladders are fall under the heading “Temporary Non-Fixed Access and Platforms”, which also covers perimeter protection and cantilevered temporary work platforms. Ladders are required to comply with the relevant New Zealand Standards. The permissible heights for single, extension and stepladders are the same as those adopted in Australia.

Sweden

Section II (27) of Part B “Specific minimum requirements for on-site workstations” of the *Ordinance of the Swedish National Board of Occupational Safety and Health containing Provisions on Building and Civil Engineering Work* (AFS 1994: 52) states:

“27.1 Falls from a height shall be physically prevented in particular by means of solid cradles which are sufficiently high and have at least a toe-guard, a main handrail and an intermediate handrail or equivalent alternative.

“27.2 In principle, work at a height shall be carried out only with appropriate equipment or using collective protection devices such as cradles, platforms and safety nets”.

It further states:

“If the use of such equipment is not possible because of the nature of the work, suitable means of access shall be provided and safety harnesses or other anchoring safety methods shall be used”

These requirements have been harmonised with the European Union’s Council Directive 92/57/EEC on the implementation of minimum safety and health requirements at temporary or mobile construction sites. The Swedish ordinance and the EU directive establish a simple dual hierarchy here.

In the first instance, collective, passive protection devices must be used to prevent falls. If this is not practicable, individual, active devices must be adopted. Ladders do not appear to belong in this hierarchy.

A number of Swedish National Board of Occupational Safety and Health ordinances preceded AFS 1994: 52:

- Protection Against Injuries Due to Falls (AFS 1981: 14)
- Work on Roofs (ASF 1983: 12)
- Provisions on Ladders and Trestles (AFS 1985: 15).

Unfortunately, these were not readily available.

European Union

In addition to provisions reproduced above in Swedish ordinance AFS 1994:52, the European Directive 92/57/EEC Part B *Specific Minimum requirements for on-site workstations*, clause 6.4 requires that:

“Ladders must be sufficiently strong and correctly maintained. They must be correctly used, in appropriate places and in accordance with their intended purpose”.

Ladders do not appear to be included in the hierarchy.

Thus, it can be seen that there is little unity across national borders, with respect to specific regulations concerning the use of stepladders.

6.6 CONCLUSION AND RECOMMENDATIONS

Despite there being no specific national Health and Safety Regulations which specifically apply to stepladders, the Regulations adequately cover all aspects of the use of ladders. However, the amended draft Directive covering Temporary Work at Heights does begin to address some of the issues relating to ladders. Considering the numbers of accidents occurring with this type of equipment, a regulation specific to ladders may be recommended. Similarly, it is clear that internationally there are few Regulations which apply specifically to stepladders. This is an area, which is currently being improved but also requires further development.

7.0 CONFORMITY WITH EUROPEAN UNION REQUIREMENTS

Directives are European-wide policy regulations, which set out essential health and safety requirements to be complied with before a product can be sold within the European economic area. Once it was established that there is no directive covering ladders or stepladders, enquiries were made in order to establish the existence of any regulations applicable to ladders. These enquiries were directed to the Department of Trade and Industry, and the Customs and Excise Advice Desk. The following response was given: there are no specific regulations to be complied with in order to sell a stepladder within the European Union. Essentially, it is the responsibility of the manufacturer to make sure that the product fits in with national safety regulations. Thus, as there is no specific directive that applies to ladders, it follows that ladders must comply with the General Product Safety Directive if they are to be sold within Europe. These issues are to be considered more fully as part of the second phase of this project.

8.0 PRODUCT REVIEW

8.1 SELECTION CRITERIA AND PURCHASE OF LADDERS

The selection process aimed to select ladders from the whole range of those available to the consumer. This required a sample of stepladders of a variety of materials (aluminium, wood and fibreglass) and representing a cross section of quality, assumed to be broadly reflected in the price.

Ladder manufacturers in the UK were contacted to request catalogues of their products. The catalogues were reviewed to identify stepladders with a BS : 2037 (domestic and industrial) and EN 131 rating. Combination ladders were also included, although these do not fall within the British Standard classification for domestic ladders. Over 100 ladders were identified, as well as the material, duty rating, height and number of treads and whether they conformed to any standard. The most common design was an aluminium stepladder with a platform and guardrail.

From this product review, eight stepladders were selected for the trials. The final ladders selected are presented in Table 15. This selection was based on criteria including popularity, height, design and material of construction. Thus, a stepladder was chosen from each category: Class 1, BS EN131, and Class 3. These were all platform stepladders with a guardrail. Subsequently, three stepladders of similar design and height, but different materials were chosen, so as to afford comparison. The latter had neither platform nor guardrail. A combination ladder was also included, as these are becoming increasingly popular, due to their multi-functionality, as was a double-sided stepladder.

Table 15
The final selection of ladders used for the trials.

Ladder	Description	Class	Max step height
A	3 way, aluminium combination	Class 3	1700 mm
B	Industrial swingback steps	Class 1	2370 mm
C	Aluminium stepladder	Class 3	1565 mm
D	Aluminium stepladder	Class 1	1545 mm
E	Timber builder's steps	Class 1	2395 mm
F	Light trade steps	BS EN 131	1795 mm
G	Fibreglass stepladder	300lbs load	2330 mm
H	Double sided Steps	Class 1	1953 mm

8.1.1 Specification of Ladders Purchased

A comprehensive specification of each ladder purchased for the study is presented in Table 16. In this specification each ladder has been described by 19 attributes relating to its dimensions, design, materials and manufacture.

This specification was compiled following observation and measurement. It was completed in order to provide descriptive information in the event of a ladder failure. The specification is not intended to be as comprehensive as technical information provided by the manufacturer.

Table 16 – Specification of the Stepladders Used in the Trials

Ladder	A	B	C	D	E	F	G	H
Model:	3 way, combination	Industrial swing back steps	Aluminium stepladder	Aluminium stepladder	Timber builder's steps	Light trade steps	Fibreglass stepladder	Double sided Steps
Price:	£60.00 +VAT	£130 + VAT	£55 + VAT	£25 + VAT	£160 + VAT	£150 + VAT	£150 + VAT	£175 + VAT
Material:	Aluminium	Aluminium	Aluminium	Aluminium	Wood	Aluminium	Fibre Glass	Aluminium
Dimensions:								
Height to platform/top when open:	1700 mm	2370 mm	1565 mm	1545 mm	2395 mm	1795 mm	2330 mm	1953 mm
Weight	5.30 kg	11.10 kg	6.40 kg	5.30 kg	18.40 kg	8.90 kg	13.10 kg	11.40 kg
Height to platform/top when closed:	1805 mm	2595 mm	2374 mm	2133 mm	2500 mm	2675 mm	2433 mm	2105 mm
Stile detail:								
Width:	50 mm	85 mm	47 mm	40 mm	70 mm	40 mm	80 mm	77mm
Length	1975 mm	2535 mm	2374 mm	2133 mm	2500 mm	2675 mm	2433 mm	2105 mm
Tread/rung detail:								
No. of treads:	5	9	6	6	9	7	7	7
Tread width (y):	48 mm	85 mm	80 mm	80 mm	88 mm	95 mm	80 mm	79 mm
Tread depth (z):	20	25mm	44 mm	37 mm	24 mm	40 mm	43 mm	30 mm
Tread length (x) at bottom step:	380 mm or splayed = 400 mm	498 mm	470 mm	510 mm	510 mm	569 mm	600 mm	440 mm
Tread length (x) at first step from top	380 mm	308 mm	345 mm	360 mm	315 mm	395 mm	370 mm	280 mm
Angle of tread (open):	Varied from 185° to 187° one side and 160° to 161°	180°	180°	180°	181	180°	180°	180°
Distance between treads:	300 mm	235 mm	235 mm	225 mm	240 mm	245 mm	290 mm	260 mm
Distance from floor to 1 st tread:	300 mm	250 mm	180 mm	200 mm	237 mm	165 mm	300 mm	250 mm
Footprint size:								
X axis	450 mm	565 mm	505 mm	540 mm	575 mm	585 mm	635 mm	510 mm
Y axis	1275 mm	1605 mm	1375 mm	1220 mm	1370 mm	1580 mm	1350 mm	1705 mm
Location of labelling:	Left side @ top	Left side @ middle	Under platform	Left side @ top	Right side @ middle	Under platform	Top cap	Only 1 side, at bottom

8.2 LIST OF ORGANISATIONS AND INDIVIDUALS CONTACTED

Appendix 7 details the organisations contacted for their opinions as part of this review, as well as the level of response recorded.

9.0 REFERENCES

ADAMS, J.

1995 Risk. *UCL Press Limited*, London.

AXELSSON, P.O. & CARTER, N.

1995 Measures to prevent portable ladder accidents in the construction industry. *Ergonomics*, **38(2)**, p.250-259.

BRITISH MEDICAL ASSOCIATION

1987 Living with risk. *John Wiley and Sons*.

BJÖRNSTIG, U. & JOHNSON, J.

1992 Ladder injuries: mechanisms, injuries and consequences. *Journal of Safety Research*, **23**, p.9-18.

BLOSWICK, D.S., CHAFFIN, D.B., ANDRES, R.O., HERRIN, G.D. & MCMAHAN, P.B.

1984 Ladder climbing biomechanics. In: *Proceedings of the 1984 International Conference on Occupational Ergonomics*. p.573-577.

CHAFFIN, D.B., MIODOSKI, R., STOBBE, T., BOYDSTUN, L. & ARMSTRONG, T.

1978 An ergonomic basis for recommendations pertaining to specific sections of OSHA Standard 29CFR Part 1910, subpart D – *Walking and working surfaces*
OSHA Department of Labor, Washington DC.

CONSUMER REPORTS

1981 Stepladders: What you want is one that's strong, stable and rigid. p.538-540.

COOPER, S. & PAGE, M.

1988 Instructions for consumer products: guidelines for better instructions and safety information for consumer products. *Consumer Safety Unit, DTI*. ISBN 011 514650 4.

CONSUMER SAFETY UNIT

1998 Writing safety instructions for consumer products. *The Qualitative Consultancy*.

DEPARTMENT OF TRADE AND INDUSTRY

1996 The Stepladder User's Guide. *A publication with the support of the British Ladder Manufacturer's Association. Consumer Safety Unit, DTI*. URN96/778.

DEPARTMENT OF TRADE AND INDUSTRY

1997 Consumer safety research: investigation into domestic use of and accidents with mobile towers. *Consumer Affairs and Competition Policy Directorate, DTI*. URN 97/750.

DEPARTMENT OF TRADE AND INDUSTRY

1997 Research Programme into the Need for Dynamic Testing of Domestic Ladders. Research Institute for Consumer Ergonomics (*RICE*) report for the *Consumer Safety Unit, DTI*.

DEPARTMENT OF TRADE AND INDUSTRY

2000 Home Accident Surveillance System including leisure activities: 22nd Annual Report 1998 data. *Consumer Safety Unit, DTI*. URN 00/32.

DEWAR, M.E.

1977 Body movements in climbing a ladder. *Ergonomics*, **20(1)**, p.67-86.

DUFRESNE, R.

1992 An Ergonomics Investigation of Ladder Users' Risk Perception. *Project Report for Postgraduate course in Ergonomics, Loughborough University of Technology.*

ERMAN, N.

1986 Ergonomic design of ladders. *Accident Analysis and Prevention*, **18(5)**, p.442.

FIELD, B., TORE. L.J., KENNINGHAM, L. & LEE, S.

2000 Strategic occupational injury prevention. Falls from heights – A report on claims, fatalities and injury severity outcomes. *Policy Research Papers, Melbourne.*

FRANTZ, J.P., RHOADES, T.P., YOUNG, S.L. & SCHILLER, J.A.

1999 Potential problems associated with overusing warnings. In: *Proceedings of the 7th International Conference on Product Safety Research, ECOSA*, Washington. p.273.

GOLDSMITH, A.

1985 The Role of Good Design and Manufacturing in Preventing Ladder Accidents. *Journal of Product Liability*, **8**, p.127–140.

GOMER, F.E.

1986 Evaluating the effectiveness of warnings under prevailing working conditions. *Proceedings of the Human Factors Society 30th Annual Meeting*, p.712-715.

HANDMER, J., & PENNING-ROUSELL, E.

1990 Hazards and the communication of risk. *Gower Technical, Aldershot*. ISBN 0 566 02784 4.

HEALTH AND SAFETY LABORATORY

2000 Analysis of accidents involving ladders. *Human Factors Group, Sheffield*

HEALTH AND SAFETY EXECUTIVE

Construction Sector - based on RIDDOR Reportable Fatal, 1997 to 2000/01 (Half year). *HSE PowerPoint Presentation*

HITCHCOCK, D., STROUD, P.

1988 A survey of ladder users. *ICE report for the Consumer Safety Unit, DTI.*

INTERNATIONAL CONSUMER RESEARCH AND TESTING

2000 Safely arriving at heights – and back to earth again. Portable ladders and stepladders. *International Consumer Research and Testing Ltd, London.*

JANICAK, C.A.

1998 Falls-related deaths in the construction industry. *Journal of Safety Research*, **29(1)**, p.35-42.

JÜPTNER, H.

1976 Safety on ladders: an ergonomic design approach. *Applied Ergonomics*, **7(4)**, p.221-223.

LAWRENCE, N., HOPKINSON, N.L., NORRIS, B.J. & WILSON, J.R.

1996 Consumer safety research: assessment of the safety of stepladders. *Consumer Safety Unit, DTI*. URN96/913.

KARNES, E. W., LEONARD, S. D. & RACHWAL, G.

1986 Effects of benign experience on the perception of risk. *Proceedings of the Human Factors Society 30th Annual Meeting* p.121-125.

LEHTO, M.R. & MILLER, J.M.

1986 Warnings: fundamentals, design and evaluation methodologies. *Fuller Technical Publications, Ann Arbor, Michigan*. ISBN 0 940537 00 1.

LEONARD, S.D., MATTHEWS, D. & KARNES, E.W.

1986 How does the population interpret warning signs? *In: Proceedings of the Human Factors Society 30th Annual Meeting*. p.116-120.

ROETHLISBERGER, F.J. & WILLIAM, J.

1939 *Management and the Worker*, Chicago.

MCGUIRE, E.P.

1988 Product-use instructions: how to evaluate them in manufacturer negligence. *Journal of Products Liability*. (11), p.293-297.

MCINTYRE, D.R.

1979 The effects of rung spacing on the mechanics of ladder ascent. *PhD Dissertation presented to the Department of Physical Education and the Graduate School of the University of Oregon*.

PARTRIDGE, R.A., VIRK, A.S. & ANTOSIA, R.E.

1998 Causes and patterns of injury from ladder falls. *Academic Emergency Medicine*, 5 (1), p.31-34.

QUELLET, B., DESSUREAULT, J. & LAURENCELLE, L.

1991 Ladder climbing. Ladder chemistry. *Travail Humain*, 54(3), p.251-265.

ROBINSON, G.H.

1986 Toward a methodology for the design of warnings. *In: Proceedings of the Human Factors Society 30th Annual Meeting*. p.106-110.

SNYDER R G.

1977 Occupational falls. Ann Arbor: *Highways Research Safety Institute*. University of Michigan.

STEWART, D.W. & MARTIN, I.M.

1994 Intended and unintended consequences of warning messages: A review and synthesis of empirical research. *Journal of Public Policy and Marketing*, 13(1), p.1-19.

STRAWBRIDGE, J.A.

1986 The influence of position, highlighting, and imbedding on warning effectiveness. *In: Proceedings of the Human Factors Society 30th Annual Meeting*, p.716-720.

THE QUALITATIVE CONSULTANCY

1998 Writing safety instructions for consumer products. *Consumer Safety Unit, DTI*. URN 98/768.

THOMPSON, D.C., THOMPSON, R.S. & RIVARA, F.P.

2001 Risk compensation theory should be subject to systematic reviews of the scientific evidence. *Injury prevention*. 7, p.86-88

VICTORIAN WORKCOVER AUTHORITY

2000 Portable Ladders: Fall protection or fall hazard? *Prevention of Falls Policy Group*, Australia

WOGALTER, M.S., ALLISON, S.T. & M^cKENNA, N.A.

1989 Effects of cost and social influence on warning compliance. *Human Factors*, **31**, p.133-140.

YATES, J.F. (Ed)

1992 Risk taking behaviour. John Wiley and Sons.

YOUNG, S.L., BRELSFORD, J.W. & WOGALTER, M.S.

1990 Judgements of hazard, risk and danger. Do they differ? *Proceedings of the Human Factors Society 34th Annual Meeting*, p.503 - 507.

10.0 STANDARDS AND REGULATIONS

ANSI Z535.1 to .4 –1991 American National Standard for Safety Color Code, Environmental and Facility Safety Signs, Criteria for Safety Symbols, Product Safety Signs and Labels and Accident Prevention Tags. *American National Standards Institute.*

ANSI Guide for developing user product information. 1990 *ANSI Consumer Interest Council.*

BS 4884 : 1992 Technical Manuals. Parts 1 - 3. *BSI Standards.*

BS 4899 : 1991/2 User's requirements for technical manuals (based on the principles of BS 4884). *BSI Standards.*

BS 2037 : 1994 : Portable aluminium ladders, steps trestles and lightweight stagings. *BSI Standards*

BS EN 131 : Ladders Part 1 : Specification for terms, types and functional sizes. *BSI Standards.*

BS EN 131 : Ladders Part 2 : Specification for requirements, testing and marking. *BSI Standards.*

British Standard (Draft) : Code of practice for the use of portable ladders, trestles and similar equipment 2001

ISO 9186: 1989 Procedures for the development and testing of public information symbols. *International Organization for Standardization, Switzerland.*

ISO GUIDE 37: 1995 Instructions for use of products of consumer interest. *International Organization for Standardization, Switzerland.*

A GUIDE TO THE CONSTRUCTION (HEALTH, SAFETY AND WELFARE) REGULATIONS 1996.

Health and Safety Executive. 1996

ANNEX: AMENDING PROPOSAL OF DIRECTIVE 89/655/EEC CONCERNING THE MINIMUM SAFETY AND HEALTH REQUIREMENTS FOR THE USE OF WORK EQUIPMENT BY WORKERS AT WORK (SECOND INDIVIDUAL DIRECTIVE WITHIN THE MEANING OF ARTICLE 16 OF DIRECTIVE 89/391/EEC) Version 4.4, March 2000 Section 4: Provisions concerning the use of work equipment provided for temporary work at height. The European Parliament and the Council of the European Union.

MANAGEMENT OF HEALTH AND SAFETY AT WORK 1999.

Approved Code of Practice and Guidance. *Health and Safety Commission, 2000*

OCCUPATIONAL HEALTH AND SAFETY (PREVENTION OF FALLS) REGULATIONS

2000. Victoria, Australia.

POWER 1998 : SAFE USE OF WORK EQUIPMENT.

Provision and Use of Work Equipment Regulations 1998. Approved Code of Practice and Guidance. *Health and Safety Commission, 1998*

THE WORKPLACE (HEALTH, SAFETY AND WELFARE) REGULATIONS 1992.

Approved Code of Practice. *Health and Safety Commission, 1992*

11.0 GLOSSARY

Bottom brace	Device which is intended to prevent the lower end of the stile from buckling
Distance between steps	The vertical gap the steps, measured as close to the stiles as possible. This distance is measured from the top surface of a step to the top surface of the next step.
Duty rating	The category assigned to a ladder which indicates the service capability of the ladder, as used in British Standard BS2037.
Handrail	Device for holding on at the upper end of a stepladder.
Inner width	The usable distance between the inner sides of the stiles.
Ladder	Device incorporating steps or rungs on which a person may step to ascend or descend.
Opening restraint/or	Device which secures the two legs of the ladder from spreader sliding apart
Platform	Topmost walking surface of a standing stepladder.
Portable ladder	Ladder which can be transported and set up without mechanical aid.
Stepladder	Portable, self-supporting ladder with steps horizontal during use.
Standing stepladder	Self-supporting stepladder, unilaterally or bilaterally ascendable: with or without platform.
Step	Climbing support with a walking surface.
Stile	Lateral part of a ladder which supports the steps as well as cross struts of supporting legs.
Top cap	The uppermost horizontal member of a portable stepladder.
Top step	The first step immediately below the top surface or top cap. When there is no top cap, the top step is the first step below the top of the rails.
Total length	Distance measured from the bottom of the foot to the top end of the top cap.
Width of the step	Distance along the walking surface of the step measured from front to back.
Visible damage	Damage visible to the eye, without recourse to optical measuring devices

Appendix 1

Table of Standards Comparison

	EN 131-2 1992	ANSI A14.1-2000	ANSI A14.2-2000	UL 184 1997	UL 112 1998	BS 1129 : 1990	13-1 Issue 1:1987 Technical Specification	AS 1657 – 1992
Specification within Standard	Max vertical Load 150kg	(Wood) Type IA 300lbs (136kg) -extra heavy duty- Type I 250lbs (113kg) Type II 225lbs (102kg) Type III 200lbs (91kg) - domestic-	(Portable metal) Stepladders longer than 20 feet shall not be supplied Extra heavy duty IA Heavy duty I Medium duty II Light duty III	(Portable Metal ladders) 300lbs (136kg) 250lbs (113kg) 225lbs (102kg) 200lbs (91kg)	(Portable wooden ladders) 300lbs (136kg) 250lbs (113kg) 225lbs (102kg) 200lbs (91kg) Max size - 20 ft	Portable timber ladders, steps, trestles and lightweight stagings Class 1: Industrial 130kg Class 2 :Light trades Class 3 :Domestic use 95kg	Portable glass fibre ladder and steps Class 1: Industrial 130kg	Fixed platforms, walkways, stairways and ladders – Design construction and installation
Distance between stiles 12 inches.(305mm) Increases from top to bottom, 1-1/4 inches per foot of stile length (104mm)	✓ Not less than 280mm	✓	✓	✓	✓ Minimum of 11 ½ inches (292mm) Increases from top to bottom, 1-1/4 inches per foot of stile length (104mm)	✓ Swing back steps - Minimum width 250 and not more than 375mm. Increases 25 to 50 mm per 500mm of stile length Platform steps - Class 1 and 3–Minimum between 325 to 330 for steps under 1800mm. Minimum 380mm for steps over 1800mm	✓ Minimum width 250mm. Increased by 12mm per tread for classes 1 & 2 and by 22mm for class 3	✓ Width not less than 450mm
Equally spaced steps between 250mm and 300mm apart, limit deviation of ±2mm	✓	✓ 12 inches ± 1/4 (305mm ± 6)	✓ 12 inches ± 1/8 (305mm ± 3)	✓ 12 inches ± 1/8 (305 ± 3.2mm)	✓ 12 inches ± 1/8 (305 ± 3.2mm)	✓ 225 to 300mm	✓ 225 to 305mm	✓ 200 to 250mm
Legs have opening restraints	✓	✓	✓	✓	✓	✓	✗	✗
Foot friction test	✗ Bottom ends of ladder to be anti-skid wood considered anti-skid	✓ Step ladder Slip Test – Preloaded ladder (200lbs). Pulling force of 35lbs at 1inch above test surface. No movement in excess of ¼ inch permitted.	✓ Step ladder Slip Test – Preloaded ladder (200lbs). Pulling force of 35lbs at 1inch above test surface. No movement in excess of ¼ inch permitted	✓ Step ladder Slip Test – Preloaded ladder (200lbs). Pulling force of 35lbs at 1inch above test surface. No movement in excess of ¼ inch (6.35mm) permitted	✓ Step ladder Slip Test – Preloaded ladder (200lbs). Pulling force of 35lbs at 1inch above test surface. No movement in excess of ¼ inch (6.35mm) permitted	✗	✗	✗
Steps have anti-skid walking surface	✓	✓ The minimum thickness of step provides for cutting of tread grooves of ¼ width and 1/16 inch depth	✓	✓	✓ The minimum thickness of step provides for cutting of tread grooves of ¼ width and 1/16 inch depth	✓ Groove not to exceed 2mm to provide non-slip surface	✓ Designed with slip resistant configuration	✓ Slip resistant surface
Length restrictions	✗	✓ Type IA Type I Type II – 3 to 12 feet Type III – 3 to 6 feet	✓ Type IA } 3 to 20 feet Type I } Type II – 3 to 12 feet Type III – 3 to 6 feet	✓ 300lbs } 3 to 20 feet 250lbs } 225lbs - 3 to 12 feet 200lbs - 3 to 6 feet	✓ 300lbs } 3 to 20 feet 250lbs } 225lbs - 3 to 12 feet 200lbs - 3 to 6 feet	✗	✓ Maximum length 6m	✓ Maximum length 6m

	EN 131-2 1992	ANSI A14.1-2000	ANSI A14.2-2000	UL 184 1997	UL 112 1998	BS 1129 : 1990	13-1 Issue 1:1987 Technical Specification	AS 1657 – 1992	
Size or thickness of step	✓ Minimum walking surface width of 80mm	✓ Working surface width from 3 to 5 1/2 inches (76.2mm to 140)	✓ Depth (working surface) not less than 3 inches (76.2mm)	✓ Depth (Working surface) not less than 3 inches (76.2mm)	✓ Depth (Working surface) from 76.2 to 108mm Minimum thickness 19.1mm	✓ Depth from 63 to 103mm Thickness from 31 to 51mm	✗	✓ Minimum depth (working surface) 100mm	
Platform Specifications	✓ <ul style="list-style-type: none"> • Minimum topmost walking surface of 250mm x 250mm • Anti skid surface • Bending test as for steps 	✓ <ul style="list-style-type: none"> • minimum width of 381mm • compression test • no failure or permanent deformation 	✓ <ul style="list-style-type: none"> • Type I, 1A and II – minimum of 356mm x 362mm • Type III – minimum of 330mm x 100mm • Platform bending test • no failure or permanent deformation 	✓ <ul style="list-style-type: none"> • Minimum of 356mm x 362mm • coated with slip-resistant material 	✓ <ul style="list-style-type: none"> • Minimum width 381mm 	✓ <ul style="list-style-type: none"> • From front to back 355 ± 25 mm 	✗	✓ <ul style="list-style-type: none"> • Fixed platform Minimum of 600mm 	
Labelling for stepladders	✓ <ul style="list-style-type: none"> • Name/date/number • Type of ladder • Maximum permissible load • Angle of use 	✓ <ul style="list-style-type: none"> • Ladder size • Duty rating • Highest standing level • Model name/number • Manufacturer • Manufacturing plant • Month/year • ANSI compliance • Danger, do not stand or sit (on top cap) • Do not stand or sit above this rung, you can lose your balance (on first step below top cap, if less than 18 inches from top cap) 	✓ <ul style="list-style-type: none"> • Ladder size • Duty rating • Highest standing level • Model name/number • Manufacturer • Manufacturing plant • Month/year • ANSI compliance • Danger, do not stand or sit (on top cap) • Do not stand or sit above this rung, you can lose your balance (on first step below top cap, if less than 18 inches from top cap) 	✓ <ul style="list-style-type: none"> • Highest standing level • Electrical shock danger • Ladder size • Duty rating • Highest standing level • Model name/number • Manufacturer • Manufacturing plant • Month/year • Ansl compliance • Danger, do not stand or sit (on top cap) • Do not stand or sit above this rung, you can lose your balance (on first step below top cap, if less than 18 inches from top cap) 	✓ <ul style="list-style-type: none"> • Highest standing level • Electrical shock danger • Ladder size • Duty rating • Highest standing level • Model name/number • Manufacturer • Manufacturing plant • Month/year • Ansl compliance • Danger, do not stand or sit (on top cap) • Do not stand or sit above this rung, you can lose your balance (on first step below top cap, if less than 18 inches from top cap) 	✓ <ul style="list-style-type: none"> • Manufacturer • BSI compliance • Class and duty rating • Never use damaged equipment • Ensure firm and level base • Check for hazards at top • Avoid electrical hazards • Avoid overreaching • Keep a secure grip • Never stand on top rail 	✓ <ul style="list-style-type: none"> • Manufacturer • Serial number • ESI 13-1 compliance 	✗	
Handrail length	✓ 600mm	✓ minimum 508mm	✓ minimum 508mm	✓ minimum 508mm	✓ minimum 508mm	✓ minimum 600mm or knee rail minimum 450mm	✗	✓ 900mm	
Opening restraint and hinges test	✓	✓	✓	✓	✓	✗	✗	✗	
Height of platform ± 5mm from mean and no visible permanent deformation shall occur		<p>Rail torsion and spreader test - Pre-loaded ladder (200lbs) horizontal force towards rear of ladder. 300lbs - 125lbs (57kg) 250lbs - 100lbs (45kg) 225lbs - 75lbs (34kg) 200lbs - 50lbs (22.7)</p> <p>Spreaders to remain locked, no major permanent deformation. Minor deformation of less than 1/8 inch (3.2mm)</p>	<p>Rail torsion and spreader test - Pre-loaded ladder (200lbs) horizontal force towards rear of ladder. 300lbs - 125lbs (57kg) 250lbs - 100lbs (45kg) 225lbs - 75lbs (34kg) 200lbs - 50lbs (22.7)</p> <p>Spreaders to remain locked, no major permanent deformation. Minor deformation of less than 1/8 inch (3.2mm)</p>	<p>Rail torsion and spreader test - Pre-loaded ladder (200lbs) horizontal force towards rear of ladder. 300lbs - 125lbs (57kg) 250lbs - 100lbs (45kg) 225lbs - 75lbs (34kg) 200lbs - 50lbs (22.7)</p> <p>Spreaders to remain locked, no major permanent deformation. Minor deformation of less than 1/8 inch (3.2mm)</p>	<p>Rail torsion and spreader test - Pre-loaded ladder (200lbs) horizontal force towards rear of ladder. 300lbs - 125lbs (57kg) 250lbs - 100lbs (45kg) 225lbs - 75lbs (34kg) 200lbs - 50lbs (22.7)</p> <p>Spreaders to remain locked, no major permanent deformation. Minor deformation of less than 1/8 inch (3.2mm)</p>				

	EN 131-2 1992	ANSI A14.1-2000	ANSI A14.2-2000	UL 184 1997	UL 112 1998	BS 1129 : 1990	13-1 Issue 1:1987 Technical Specification	AS 1657 – 1992
Lateral deflection test of supporting leg – pre-load of 100 N for 1 minute, then 250 N for 1 minute. Max. deflection 0.5% of the length of the step	✓	✗	✓ No pre-load. Load applied for one minute 200lbs (907N) 175lbs (793N) 150lbs (680N) 125lbs (567N) Permanent deformation not to exceed 6.4mm	✓ No pre-load. Load applied for one minute 200lbs (907N) 175lbs (793N) 150lbs (680N) 125lbs (567N) Permanent deformation not to exceed 6.4mm	✗	✗	✗	✗
Bottom stile ends test – 900N at 50mm width, for 1 minute. Permanent deflection must not exceed 2mm, no cracks or fractures allowed	✓	✗	✓ Load applied for one minute 200lbs (907N) 175lbs (793N) 150lbs (680N) 125lbs (567N) Permanent deformation not to exceed 6.4mm	✓ Load applied for one minute 200lbs (907N) 175lbs (793N) 150lbs (680N) 125lbs (567N) Permanent deformation not to exceed 6.4mm	✗	✗	✗	✗
Tread and platform bending test – Pre-load 200N for 1 minute, then 2600N vertically, over 100mm for 1 minute. Max. deformation 0,5% of length of step	✓	✗	✓ No pre-load Loaded for 1 minute according to duty rating: Type IA 4530 N Type I 4080 N Type II 3850 N Type III 3628 N Max permanent deformation, 1% of length of the step	✓ No pre-load Loaded for 1 minute according to duty rating: Type IA 4530 N Type I 4080 N Type II 3850 N Type III 3628 N Max permanent deformation, 1% of length of the step	✓ Loaded for 1 minute according to duty rating: Type IA 4530 N Type I 4080 N Type II 3850 N Type III 3628 N Max permanent deformation, 1% of length of the step	✗	✓ Loaded for 1 minute according to duty rating: Type IA 4530 N Type I 4080 N Type II 3850 N Type III 3628 N Max permanent deformation, 1% of length of the step	✗
Step torsion test – Torque of 50 N m applied over 100mm. 10 times clockwise and 10 anticlockwise for 10 seconds each time. No relative movement in stile step. Permanent deformation max. ±1°	✓	✗	✗	✗	✗	✗	✗	✗
Torsional stability test - Pre-loaded ladder (200lbs) Horizontal force towards rear of ladder. 300lbs - 125lbs (57kg) 250lbs - 100lbs (45kg) 225lbs - 75lbs (34kg) 200lbs - 50lbs (22.7) No movement with respect to the floor, in excess of 1 inch (25mm). No major permanent deformation. Minor deformation of less than 1/8 inch	✗	✓ Type IA 30lbs (14kg) Type I 30lbs (14kg) Type II 25lbs (11kg) Type III 20lbs (9kg) No movement with respect to the floor, in excess of 1 inch (25mm). No major permanent deformation. Minor deformation of less than 1/8 inch acceptable(3mm)	✓ Type IA 30lbs (14kg) Type I 30lbs (14kg) Type II 25lbs (11kg) Type III 20lbs (9kg) No movement with respect to the floor, in excess of 1 inch (25mm). No major permanent deformation. Minor deformation of less than 1/8 inch acceptable(3mm)	✓ Type IA 30lbs (14kg) Type I 30lbs (14kg) Type II 25lbs (11kg) Type III 20lbs (9kg) No movement with respect to the floor, in excess of 1 inch (25mm). No major permanent deformation. Minor deformation of less than 1/8 inch acceptable(3mm)	✓ Type IA 30lbs (14kg) Type I 30lbs (14kg) Type II 25lbs (11kg) Type III 20lbs (9kg) No movement with respect to the floor, in excess of 1 inch (25mm). No major permanent deformation. Minor deformation of less than 1/8 inch acceptable(3mm)	✗	✗	✗

	EN 131-2 1992	ANSI A14.1-2000	ANSI A14.2-2000	UL 184 1997	UL 112 1998	BS 1129 : 1990	13-1 Issue 1:1987 Technical Specification	AS 1657 – 1992
<p>Stability test – pre-loaded with 120kg, then tested non simultaneously - forces to front (15kg), side (12kg), and rear (25.5kg) –</p> <p>Bottom surface of stiles and back legs shall remain in contact with the level surface</p>	✘	✓ Pre-loaded ladder (200lbs) Front (f) side (s) and rear (r) stability test – Pulling forces of 25 lb (f), 22 lb (s) and 45 lb (r) Must not tip over, no visible damage or test failure	✓ Pre-loaded ladder (200lbs) Front (f) side (s) and rear (r) stability test – Pulling forces of 25 lb (f), 22 lb (s) and 45 lb (r) Must not tip over, no visible damage or test failure	✓ Pre-loaded ladder (200lbs) Front (f) side (s) and rear (r) stability test – Pulling forces of 25 lb (f), 22 lb (s) and 45 lb (r) Must not tip over, no visible damage or test failure	✓ Pre-loaded ladder (200lbs) Front (f) side (s) and rear (r) stability test – Pulling forces of 25 lb (f), 22 lb (s) and 45 lb (r) Must not tip over, no visible damage or test failure	✘	✓ Pre-loaded ladder (200lbs) Front (f) side (s) and rear (r) stability test – Pulling forces of 25 lb (f), 20 (s) and 45 (r) Must not tip over	✘
<p>Walking test – 10kg load applied, horizontal force applied by hand and released x 5. Opening restraints remained locked and walking distance W=20L^{1.65}</p>	✘	✘	✘	✘	✘	✘	✘	✘

	ANSI A14.5-2000	AS/NZS 1892.1:1996	BS 2037 : 1994	CAN3-Z11-M81
Specification within Standard	(Portable reinforced plastic) Stepladders longer than 20 feet shall not be supplied	(Metal) Load 120kg for Industrial 100kg for domestic	Portable aluminium ladders, steps, trestles and lightweight stagings Class 1: Industrial 130kg Class 2: Light trades Class 3: Domestic use 95kg	(Portable ladders) Grade 1 Industrial – heavy use Grade 2 Tradesman and farm – Medium Grade 3 Household - Light
Horizontal distance between stiles 12 inches.(305mm) Increases from top to bottom, 1-1/4 inches per foot of stile length (104mm)	✓	✓	✓ Minimum width for parallel-sided ladders is 355mm. Minimum for other stepladders is 250mm. Increased by 12mm per tread for classes 1 & 2 and by 22mm for class 3	✓ Stepladders - From top to bottom, increases a minimum of 1 mm/10 mm 1.2 in/ft of side-rail length Platform – Minimum clear width 350 mm (14 in). Small platform ladders, minimum width 330 mm (13 in), increasing 1 mm/12 _ (1 in/ft)
Equally spaced steps between 250mm and 300mm apart, limit deviation of ±2mm	✓ 12 inches ± 1/8 (305 mm ± 3)	✓ 248 ±2mm to 306 ±2mm	✓ 225 to 300mm	✓ 300 mm
Legs have opening restraints	✓	✓	✓	✓
Foot friction test	✓ Step ladder Slip Test – Preloaded ladder (200lbs). Pulling force of 35lbs at 1inch above test surface. No movement in excess of ¼ inch permitted	✓ Material to resist slipping. Coefficient of static friction not less than 0.5	✗ Feet to be soled with hardwood, plastics or rubber	✗
Steps have anti-skid walking surface	✓	✓	✓ Treads have textured upper surfaces	✓
Length restrictions	✓ Type IA Type I Type II - 3 to 12 feet Type III - 3 to 6 feet	✓ 6.1m for industrial 2.4m for domestic	✓ Class 1: 16 treads Class 2: 10 treads Class 3: 9 treads	✓ Grade 1 Less than 20 feet Grade 2 Less than 12 feet Grade 3 Less than 6.5 feet
Minimum working surface or width of step	✓ Minimum working surface width of 3 inches (76.2mm)	✓ Working surface width not less than 75mm	✓ Not less than 75mm wide	✓ Minimum working surface width of (75 mm) 3 inches
Platform Specifications	✓ Type I, 1A and II – minimum of 129032 mm ² (200 in ²) Type III – 83870.8 mm ² (130 square inches)	✓ • Top cap minimum of 75mm from front to back • Bending test as for steps	✓ • Minimum of 250mm x 250mm • Textured surface • Bending test as for steps	✓ Platform – minimum of 129032 mm ² (200 in ²) Small platform ladders, minimum width 85000 mm ² (130 in ²), and not more than 170000 mm ² (250 in ²)

	ANSI A14.5-2000	AS/NZS 1892.1:1996	BS 2037 : 1994	CAN3-Z11-M81
Labelling for stepladders	✓ <ul style="list-style-type: none"> Ladder size Duty rating Highest standing level Model name/number Manufacturer Manufacturing plant Month/year ANSI compliance Danger, do not stand or sit (on top cap) Do not stand or sit above this rung, you can lose your balance (on first step below top cap, if less than 18 inches from top cap) 	✓ <ul style="list-style-type: none"> Manufacturer Duty rating Electrical hazard To be used fully open Not to stand higher than second top tread, if not platform ladder 	✓ <ul style="list-style-type: none"> Manufacturer BSI compliance Class and duty rating Never use damaged equipment Ensure firm and level base Check for hazards at top Avoid electrical hazards Avoid overreaching Keep a secure grip Never stand on top rail 	✓ <ul style="list-style-type: none"> Manufacturer Month/year Ladder size Grade, projected use and load rating Keep feet firm and level Check ladder before use. Lock spreaders. The use of damaged ladders can be dangerous Do not overreach Do not stand or sit on top Avoid contact with electrical wiring or devices;
Handrail length	✓ Minimum 508 mm	✗	✗	✓ Minimum 500 mm
Opening restraint and hinges test	✓ Rail torsion and spreader test - Pre-loaded ladder (200lbs) horizontal force towards rear of ladder. 300lbs – 125lbs (57kg) 250lbs – 100lbs (45kg) 225lbs – 75lbs (34kg) 200lbs – 50lbs (22.7) Spreader to remain locked, no major permanent deformation. Minor deformation of less than 1/8 inch (3.2mm)	✗	✗	✗
Height of platform ± 5mm from mean and no visible permanent deformation shall occur				
Lateral deflection test of supporting leg – pre-load of 100 N for 1 minute, then 250 N for 1 minute. Max. deflection 0.5% of the length of the step	✗	✓ 980 N at back stile. Permanent deformation 6mm	✗	✗
Bottom stile ends test (including supporting legs)– 900N at 50mm width, for 1 minute. Permanent deflection must not exceed 2mm, no cracks or fractures allowed	✓ Load applied for one minute 200lbs (907N) 175lbs (793N) 150lbs (680N) 125lbs (567N) Permanent deformation not to exceed 6.4mm	✓ 1470 N at 50mm, Permanent deflection 2mm	✓ Test load Class 1: 125kg (1250N) Class 2: 120kg (1200N) Class 3: 90kg (900N) Maximum permanent deformation 6mm	✓ Front/rear rail Grade 1 200lb/125 Grade 2 150/100 Grade 3 100/75
Tread and platform bending test – Pre-load 200N for 1 minute, then 2600N vertically, over 100mm for 1 minute. Max. deformation 0,5% of length of step	✓ No pre-load Loaded for 1 minute according to duty rating: Type IA 4530 N Type I 4080 N Type II 3850 N Type III 3628 N Max permanent deformation, 1% of length of the step	✓	✓ Test load Class 1: 225kg (2250N) Class 2: 200kg (2000N) Class 3: 180kg (1800N) Max permanent deformation 1mm	✓ No pre-load Loaded for 1 minute according to grade Grade 1 410lb/9000N Grade 2 385lb/8500N Grade 3 360lb/8000N Max permanent deformation, 1% of length of the step

	ANSI A14.5-2000	AS/NZS 1892.1:1996	BS 2037 : 1994	CAN3-Z11-M81
<p>Step torsion test – Torque of 50 N m applied over 100mm. 10 times clockwise and 10 anticlockwise for 10 seconds each time. No relative movement in stile step. Permanent deformation max. ±1°</p>	x	✓ Torque of 100 N m applied, clock and anti clockwise, x 10 No relative movement in stile step	x	x
<p>Torsional stability test - Pre-loaded ladder (200lbs) Horizontal force towards rear of ladder. 300lbs - 125lbs (57kg) 250lbs - 100lbs (45kg) 225lbs - 75lbs (34kg) 200lbs - 50lbs (22.7) No movement with respect to the floor, in excess of 1 inch (25mm). No major permanent deformation. Minor deformation of less than 1/8 inch</p>	✓ Type IA 30lbs (14kg) Type I 30lbs (14kg) Type II 25lbs (11kg) Type III 20lbs (9kg) No movement with respect to the floor, in excess of 1 inch (25mm). No major permanent deformation. Minor deformation of less than 1/8 inch acceptable(3mm)	x	x	✓ A horizontal force increasing to 85 N directed to rear of ladder. No movement with respect to the floor, in excess of 1 inch (25mm), until force exceeds 85N (8.5kg). No major permanent deformation. Minor deformation of less than 1/8 inch acceptable(3mm)
<p>Stability test – pre-loaded with 120 kg (264 lb), then tested non simultaneously - forces to front (15kg), side (12kg), and rear (25.5kg) – Bottom surface of stiles and back legs shall remain in contact with the level surface</p>	✓ Pre-loaded ladder 200 lb (91 kg) Front (f) side (s) and rear (r) stability test – Pulling forces of 25 lb (f), 20 lb (s) and 45 lb (r) Must not tip over, no visible damage or test failure	✓	x	✓ Pre-loaded ladder 90 kg (198 kg) Front (f) side (s) and rear (r) stability test – Pulling forces of 25 lb (f), 22 lb (s) and 45 lb (r) Must not tip over.
<p>Walking test – 10kg load applied, horizontal force applied by hand and released x 5. Opening restraints remained locked and walking distance $W=20L^{1.85}$</p>	x	✓	x	x

Appendix 2

Ladder Products Reviewed

Manufacturer	Material	Ladder type	Duty rating	Treads	Height to platform	Conforms to standard
Blueseal	Aluminium	Platform stepladder	Class 1	3 to 8	1500 mm	BS 2037
Blueseal	Aluminium	3 way ladder	Class 1	- n/k	1560 mm	BS 2037
Blueseal	Aluminium	Steps, dual handrails	Class 1	3 to 8	1790 mm	BS 2037
ABRU	Aluminium	Combination ladder	None	- n/k	2100 mm to top tread	BS EN131
BPS ladders	Aluminium	Atlas steps	Class 3	3 to 8	1790 mm	BS 2037
BPS ladders	Aluminium	Aluminium Builders steps	Class 1	5 to 14	2900 mm to top tread	BS 2037
BPS ladders	Timber	Timber Builders steps	Class 1	6 to 10	2300 mm to top tread	BS 1129
BPS ladders	Aluminium	Aluminium steps	Class 1	6 to 12	2500 mm	BS 2037
BPS ladders	Aluminium	Aluminium - light trade steps	150 kgs	3 to 8	1800 mm	BS EN131
BPS ladders	Aluminium	Aluminium climalux steps	None	3 to 8	1800 mm	BS EN131
SGB Youngman	Aluminium	Industrial platform step ladder	Class 1	3 to 12	2520 mm	BS 2037
BLMA	Aluminium	Industrial aluminium swingback steps	Class 1	4 to 14	3300 mm	BS 2037
BLMA	Aluminium	Aluminium industrial platform steps	Class 1	5 to 12	2800 mm	BS 2037
BLMA	Timber	Timber builders steps	Class 1	5 to 12	2900 mm	BS 1129
BLMA	Timber	Timber platform steps	Class 1	5 to 12	2900 mm	BS 1129
Aluval	Aluminium	Aluminium, with handrail,	Class 3	2 to 7	1560 mm	BS 2037
Aluval	Aluminium	Aluminium 3 way ladder,	Class 3	- n/k	1560 mm	BS 2037
Aluval	Aluminium	Aluminium all in one	Class 3	- n/k	1800 mm to top of stile	BS EN131
Parrs	Aluminium	Light industrial	Class 1	3 to 10	2370 mm	BS 2037
Parrs	Aluminium	Heavy duty steps, larger platform,	Class 1	6 to 16	3780 mm	BS 2037
Parrs	Aluminium	Double sided	Class 1	7 to 10	2355 mm	BS 2037
Parrs	Aluminium	Adjustable	None	- n/k	2438 mm	None
Parrs	Aluminium	Three way stepladder,	Class 1	- n/k	3100 mm	BS 2037
Parrs	Glass fibre	Swing back steps	None	4 to 10	2540 mm	None
Parrs	Timber	Swing back steps	Class 1	5 to 12	2970 mm	BS 1129
Parrs	Timber	Platform steps	Class 1	6 to 15	3500 mm	BS 1129
Bs	Aluminium	3 way steps	Class 1	- n/k	1560 mm	BS 2037
Bs	Aluminium	Combined step and ladder	None	- n/k	1980 mm	None
Bs	Aluminium	Professional adjustable ladder	Class 1	- n/k	2300 mm	BS 2037
Bs	Aluminium	Double sided steps	Class 1	5 to 8	1950 mm	BS 2037
Bs	Aluminium	Industrial swingback steps	Class 1	3 to 12	2570 mm	BS EN131
Bs	Aluminium	Industrial platform steps	Class 1	3 to 12	2570 mm	BS 2037

Manufacturer	Material	Ladder type	Duty rating	Treads	Height to platform	Conforms to standard
Bs	Aluminium	Combination ladder, for trade and DIY	None	- n/k	6500 mm	BS EN131
Bs	Glass fibre	Platform steps	None	3 to 12	2580mm	BS EN131
Bs	Glass fibre	Swing back steps	None	3 to 12	2570 mm	BS EN131
Bs	Glass fibre	Heavy duty, platform steps	None	4 to 12	2090 mm	BS EN131
Bs	Glass fibre	Heavy duty, swing back steps	None	4 to 12	2030 mm	BS EN131
KXT	Aluminium	Builders steps	Class 1	3 to 13	3250 mm	BS 2037
KXT	Aluminium	Industrial platform steps	Class 1	3 to 13	3250 mm	BS 2037
KXT	Aluminium	Light duty steps, auto locking platform	Class 3	3 to 7	1630 mm	domestic
KXT	Aluminium	Folding step ladders	None	3 to 5	1470 mm	None
KXT	Glass fibre	Non conductive steps	None	3 to 7	2440 mm	domestic
Bratts	Timber	Swing back steps, for industrial use	Class 1	- n/k	2970 mm	BS1129
Bratts	Timber	Trade pattern	None	- n/k	2540 mm	BS1129
Bratts	Timber	Platform steps	Class 1	- n/k	3500 mm	BS1129
Bratts	Timber	Double sided folding steps	None	- n/k	3120 mm	BS1129
Bratts	Glass fibre	One way, aluminium treads	None	4 to 10	2540 mm	BS EN131, ESI 13-1
Bratts	Glass fibre	Swing back steps with glass fibre treads	None	4 to 10	2540 mm	BS EN131, ESI 13-1
Bratts	Glass fibre	Folding platform with aluminium treads	None	4 to 10	2430 mm	BS EN131, ESI 13-1
Bratts	Glass fibre	Folding platform with Glass fibre treads	None	4 to 10	3050 mm	BS EN131, ESI 13-1
Bratts	Glass fibre	Double sided steps, aluminium treads	None	4 to 10	2590 mm	BS EN131, ESI 13-1
Bratts	Glass fibre	Double sided steps, glass fibre steps	None	4 to 10	2590 mm	BS EN131, ESI 13-1
Bratts	Aluminium	Combination ladder	Class 1	- n/k	closed length 3050 mm	BS 2037
Bratts	Aluminium	Platform steps	Class 1	3 to 24	5660 mm	BS 2037
Bratts	Aluminium	Swingback steps	Class 1	3 to 12	2820 mm	BS 2037
Bratts	Aluminium	Swingback steps	Class 1	3 to 20	4705 mm	BS 2037
Bratts	Aluminium	Swingback steps	Class 1	2 to 6	1400 mm	BS 2037
Bratts	Aluminium	Double sided steps	Class 1	4 to 10	2400 mm	BS 2037
Bratts	Aluminium	Platform steps	Class 1	2 to 10	2370 mm	BS 2037
Titan	Aluminium	Combination ladder	150kgs	7 to 12	5600 mm	BS EN131
Titan	Aluminium	Folding ladder, with splayed legs	150kgs	- n/k	-	BS EN131
Titan	Timber	Builders steps, industrial pattern	Class 1	6 to 12	2800 mm	BS 1129
Titan	Timber	Builders steps, trade pattern	None	6 to 12	2600 mm	None

Manufacturer	Material	Ladder type	Duty rating	Treads	Height to platform	Conforms to standard
Titan	Aluminium	Folding ladders, with stabiliser	150kgs	- n/k	-	BS EN131
Titan	Aluminium	Industrial platform steps	Class 1	6 to 12	2900 mm	BS 2037
Titan	Aluminium	Painter's steps	Class 1	5 to 13	3100 mm	BS 2037
Titan	Aluminium	Double sided steps, trade and industrial	Class 1	3 to 8	2000 mm	BS 2037
Titan	Aluminium	Combination stepladder for tradesmen	None	- n/k	2000 mm	None
Titan	Aluminium	Platform steps	150kgs	2 to 8	1800 mm	BS EN131
Titan	Aluminium	Compact platform stepladder	150kgs	3 to 7	1600 mm	BS EN131
Titan	Aluminium	Platform steps	Class 3	2 to 8	1800 mm	BS 2037
Titan	Aluminium	3 way ladder, domestic	None	5	-	None
Titan	Fibreglass	Painters steps, aluminium treads	250kgs	5 to 10	2310 mm	None
Titan	Fibreglass	Double sided, aluminium treads	250kgs	6 to 12	3350 mm	None
Titan	Fibreglass	Platform steps, aluminium treads	300lbs	6 to 10	2900 mm	None
Titan	Fibreglass	Combination stepladder, aluminium treads	300lbs	- n/k	2300 mm	None
Ramsay	Aluminium	Combination ladders	None	- n/k	3050 mm	BS 2037
Ramsay	Aluminium	Platform steps	Class 1	3 to 24	6570 mm	BS 2037
Ramsay	Aluminium	Platform steps	Class 1	2 to 10	3070 mm	BS 2037
Ramsay	Aluminium	Swingback steps	Class 1	3 to 12	3140 mm	BS 2037
Ramsay	Aluminium	Swingback steps	Class 1	3 to 20	4700 mm	BS 2037
Ramsay	Aluminium	Swingback steps	Class 1	2 to 6	1625 mm	BS 2037
Ramsay	Aluminium	Double sided steps	Class 1	4 to 10	2350 mm	BS 2037
Ramsay	Timber	Swingback steps	Class 1	5 to 12	2740 mm	BS 1129
Ramsay	Timber	Platform steps	Class 1	6 to 12	2790 mm	BS 1129
Ramsay	Glassfibre	Platform step	None	4 to 10	2430 mm	BS EN131, ESI 13-1
Ramsay	Glassfibre	Swingback steps	None	4 to 10	2275 mm	BS EN131, ESI 13-1
Zarges	Aluminium	Mastersteps	None	3 to 10	3000 mm	None
Zarges	Aluminium	Platform steps	150kgs	3 to 10	2210 mm	BS EN131
Zarges	Aluminium	Aluminium stepladder with platform,	150kgs	3 to 8	1770 mm	BS EN131
Zarges	Aluminium	Aluminium builder/painters steps	Class 1	5 to 13	3170 mm	BS 2037
Zarges	Aluminium	Platform steps	Class 1	6 to 12	2250 mm	BS EN131
Zarges	Timber	Timber builders/painters steps	None	6 to 12	4010 mm	BS 1129
Zarges	Aluminium	Aluminium swingback steps,	Class 1	4 to 12	2550 mm	BS EN131

Manufacturer	Material	Ladder type	Duty rating	Treads	Height to platform	Conforms to standard
Zarges	Aluminium	Aluminium double sided swingback	None	2 x 7	1650 mm	BS EN131
Kingfisher ladders	Fibreglass	Double sided steps	Class 1	- n/k	3600 mm	None
Kingfisher ladders	Fibreglass	Transformable	Class 1	-n/k	3300 mm	None
Kingfisher ladders	Fibreglass	Compact platform stepladder	Class 1	- n/k	1600 mm	None
Kingfisher ladders	Aluminium	Super stepladder	Class 1	- n/k	2800 mm	BS EN131
Kingfisher ladders	Aluminium	Multi purpose ladder	Class 3	- n/k	1200 mm	BS EN131
Kingfisher ladders	Aluminium	5 way mini scaffold	Class 3	- n/k	1700 mm to top of stile	None

Appendix 3

Example Letter – Agencies

Dear Sir/Madam,

Re: Stability of Step Ladders

The Research Institute for Consumer Ergonomics is currently undertaking research on behalf of the Health and Safety Executive investigating the stability of stepladders. The contract has arisen out of the fact that recent research has highlighted a high level of accidents involving stepladders occurring each year. A comparison of British and European Standards has also found that neither contain stability tests.

Therefore the research is aimed at improving the level of stepladder safety and therefore reduce the number of accidents which occur during their use.

We are currently investigating what research has already been done in the area of stepladder stability and what solutions have been adopted by the industry, both in terms of design and the information which is provided for the retailer and purchaser.

Therefore we would be grateful if you could provide any information specifically about the following:

- Examples of any advice leaflets for consumers
- In-house training information
- In-house published research.
- Information about returns/complaints which relate to stability issues,
- Issues arising from consumer misuse which have caused a stability problem.
- General comments relating stepladder retailing.

All information will be treated in strict confidence.

At a later point in the research we envisage that we will be conducting subjective testing on a number of different ladder designs. With this in mind, would it be possible for you to send us sales information about your current range of stepladders and supply details.

If you wish to know any further information about the research please contact me on 01509 283300, or email me on the address below.

Thanking you in anticipation of your help.

Yours faithfully,

.....

Appendix 4

Example Letter – Manufacturers

Dear Sir/Madam,

Re: Stability of Step Ladders

The Research Institute for Consumer Ergonomics is currently undertaking research on behalf of the Health and Safety Executive investigating the stability of stepladders. The contract has arisen out of the fact that recent research has highlighted a high level of accidents involving stepladders occurring each year. A comparison of British and European Standards has also found that neither contain stability tests.

Therefore the research is aimed at improving the level of stepladder safety and therefore reduce the number of accidents which occur during their use.

We are currently investigating what research has already been done in the area of stepladder stability and what solutions have been adopted by the industry, both in terms of design and the information which is provided for the retailer and purchaser.

Therefore we would be grateful if you could provide any information specifically about the following:

- Design details to improve the stability of stepladders you currently manufacture.
- Published research.
- Information about returns/complaints which relate to stability issues,
- Issues arising from consumer misuse which have caused a stability problem.
- Any training information or publicity material relating to using stepladders.

All information will be treated in strict confidence.

At a later point in the research we envisage that we will be conducting subjective testing on a number of different ladder designs. With this in mind, would it be possible for you to send us sales information about your current range of stepladders and supply details.

If you wish to know any further information about the research please contact me on 01509 283300, or email me on the address below.

Thanking you in anticipation of your help.

Yours faithfully,

.....

Appendix 5

Example Letter – Hire Shops

Dear Sir/Madam,

Re: Stability of Step Ladders

The Research Institute for Consumer Ergonomics is currently undertaking research on behalf of the Health and Safety Executive investigating the stability of stepladders. The contract has arisen out of the fact that recent research has highlighted a high level of accidents involving stepladders occurring each year. A comparison of British and European Standards has also found that neither contain stability tests.

Therefore the research is aimed at improving the level of stepladder safety and therefore reduce the number of accidents which occur during their use.

We are currently investigating what research has already been done in the area of stepladder stability and what solutions have been adopted by the industry, both in terms of design and the information which is provided for the retailer and purchaser.

Therefore we would be grateful if you could provide any information specifically about the following:

- Advice leaflets given to customers relating on safe stepladder usage
- Information given at point of hire.
- Information about returns/complaints which relate to stability issues,
- Issues arising from consumer misuse.
- Any in house training information.

All information will be treated in strict confidence.

If you wish to know any further information about the research please contact me on 01509 283300, or email me on the address below.

Thanking you in anticipation of your help.

Yours faithfully

.....

Appendix 6

Example Letter – Consumer Associations

Dear Sir/Madam,

Re: Stability of Step Ladders

The Research Institute for Consumer Ergonomics is currently undertaking research on behalf of the Health and Safety Executive investigating the stability of stepladders. The contract has arisen out of the fact that recent research has highlighted a high level of accidents involving stepladders occurring each year. A comparison of British and European Standards has also found that neither contain stability tests.

Therefore the research is aimed at improving the level of stepladder safety and therefore reduce the number of accidents which occur during their use.

We are currently investigating what research has already been done in the area of stepladder stability and what solutions have been adopted by the industry, both in terms of design and the information which is provided for the retailer and purchaser.

Therefore we would be grateful if you could provide any information specifically about the following:

- Press releases relating to stepladders.
- Published research/information/publicity material relating to using stepladders.
- Any consumer information related to the topic.
- Issues arising from consumer complaints or misuse which have caused a stability problem.

All information will be treated in strict confidence.

If you wish to know any further information about the research please contact me on 01509 283300, or email me on the address below.

Thanking you in anticipation of your help.

Yours faithfully,

.....

Appendix 7

People, Organisations and Agencies Contacted

Company	Letter Response		Telephone Response	
	YES	NO	YES	NO
1st Call Hire & Sales Ltd		✓		✓
A J B Products Ltd		✓		✓
A B Chance UK Ltd		✓		✓
A Bratt & Son Ltd	✓			
Abacus Hire Centre		✓		✓
Abru Ltd	✓		✓	
Access Ladders		✓	✓	
Acorn Hire Ltd		✓		✓
Action Ltd		✓		✓
Akro Plant Ltd		✓		✓
Al Murad DIY		✓	✓	
Alan Davies (Stainless) Ltd		✓	✓	
Alan Hewitt Ltd		✓	✓	
Alexandra Hire Services Ltd	✓			
Alide Plant Services Ltd		✓		✓
Alloy Ladder Co		✓		✓
Alton Industries (GB) Ltd		✓		✓
American Ladder Institute	✓			
American Nationl Stand Inst		✓		✓
Amercan Society of Safety Engineers		✓	✓	
American Subcontractors		✓		✓
Ankalad		✓		✓
Arco East Midlands		✓		✓
Argos Ltd		✓	✓	
Ash of Ancoats		✓	✓	
Asfield DIY		✓	✓	
Associated General Contractors		✓		✓
Association Portugesa	✓			
Association des consommateurs	✓			
Associazione Consumatori		✓		✓
Austin Group Yorkshire Ladders		✓	✓	
Austin White Ladders		✓	✓	
B & W Loft Ladders		✓		✓
B D S Ladders Ltd		✓	✓	

Company	Letter Response		Telephone Response	
	YES	NO	YES	NO
Beldray Ltd	✓			✓
Bobs DIY		✓	✓	
Bonanza DIT		✓	✓	
Bradford Ladder Co		✓	✓	
Brian Marsh	✓		✓	
British Safety Council	✓			
British Standards Institute	✓			✓
Browns Ladders		✓	✓	
Brunel Towers Ltd		✓	✓	
Building Research Establishment		✓		✓
Bureau European de Sumons		✓		✓
Burton Wire & Tube Co		✓	✓	
C P hire		✓		✓
C P Hire Belfast		✓		✓
C A Brown Ladders		✓	✓	
Cameron & Moore (Gridplex)		✓		✓
CEN		✓		✓
Chase Manufacturing			✓	✓
Clow Group Limited		✓	✓	
Conningsby Metal		✓		✓
Construction Industry		✓		✓
Consummentenbond (CB)		✓		✓
Consumer Council Denmark		✓		✓
Consumers Association (CA)		✓		✓
Consumers Association (Canada)		✓		✓
Consumers Association (Ireland)	✓			
Conways DIY Centre		✓		✓
Dave Mornington	✓		✓	
DIY Centre		✓		✓
Dart Ltd		✓		✓
Dee Bees DIY		✓	✓	
Delyn Hire		✓		✓
Discount Home Supplies		✓	✓	
Do-it-yourself Shop		✓	✓	
Draper Tool Company		✓		✓
Drew Clark & Co		✓		✓
Dunric DIY		✓	✓	
Dunwoodys		✓		✓
E H Bailey & Co Ltd	✓			
E V B Engineering Ltd		✓	✓	
Edwards Pland & Tool Hire		✓		✓
Ekipizol Consumers Association		✓		✓
Enfield Safety Supplies		✓		✓

Company	Letter Response		Telephone Response	
	YES	NO	YES	NO
Essener Equipment Co		✓		✓
European Association for the co-ordination		✓		✓
Evonlode DIY		✓	✓	
F Parr Ltd		✓		✓
F L Wraight & Co Ltd		✓	✓	
F R Palmer Ltd		✓		✓
F A Heffer & CO		✓		✓
Featherline Industries Ltd		✓		✓
Federation Romande des Consommateurs	✓			
Freds DIY		✓	✓	
Freemans		✓		✓
G C Dewey & Son Ltd		✓		✓
G P C Industries		✓	✓	
Gastle Fabrications		✓		✓
Geoffs DIY		✓	✓	
Globe Ladders		✓	✓	
Godfrey DIY Superstores		✓		✓
Grattans Plc		✓		✓
Great Mills Retail Ltd		✓		✓
Great Universal Stores		✓		✓
Green Bull		✓		✓
Greengate Construction		✓		✓
Greenham Trading Ltd		✓		✓
Guardrail Fabrication Ltd		✓		✓
Gutters and Ladders		✓	✓	
H C Slingsby Plc	✓			
Handi Hire		✓		✓
Hartley Hire		✓		✓
Hedley Handling		✓	✓	
Higgins Hire		✓		✓
Hi-Grear Tool Hire		✓		✓
Hire It		✓		✓
Hire Stores Ltd		✓		✓
Hollaender Rouner Ltd		✓	✓	
Holland Ladder & Manufacturers		✓		✓
HSS Hire Shop		✓		✓
Hydrosteps Ltd		✓	✓	
In 2 DIY		✓		✓
International Consumers		✓		✓
Isaac Lord Ltd		✓	✓	
Ireland Hire Centre		✓		✓
J & J Enright		✓	✓	
J Gorstidge Ltd		✓	✓	
Jewson Direct		✓		✓

Company	Letter Response		Telephone Response	
	YES	NO	YES	NO
John S Tilley Ladder Co		✓		✓
King & Stevens Ltd		✓		✓
Kingfisher Ladders		✓	✓	
Kon Sumentverket-Ko		✓		✓
Krause Inc		✓		✓
Kuluttajavirasto (KUV)		✓		✓
Kursaal Tool Hire		✓		✓
Ladder & Fencing Industries		✓		✓
Ladder Finder		✓		✓
Ladder Craft Ltd	✓			
Langbridge		✓		✓
Lansford Access Ltd		✓	✓	
Leicester Shelving UK Ltd				✓
Littlewoods & Sons		✓	✓	
Louisville Ladder Group		✓		✓
Lynn Ladder & Scaffolding		✓		✓
Lyte Industries		✓		✓
M & S Supplies		✓		✓
MG Ladder & Access		✓		✓
M R P Trucks & Trolleys		✓	✓	
Machine Mart Ltd		✓		✓
Mackays of cambridge Ltd		✓	✓	
Metallic Ladder Manufacturers		✓		✓
Michigan Ladder Co		✓		✓
Midland Ladder Co		✓	✓	
Mr Lofty		✓		✓
N S G Services Group Plc		✓		✓
Newlins Ltd		✓		✓
Next Plc		✓		✓
Oldham Plant Hire		✓		✓
Orange Ladders Ltd		✓	✓	
Organisation Generale des Consommateurs		✓		✓
Peter Greenwood		✓		✓
P P Paul		✓	✓	
Power Access Systems		✓	✓	
Powersure Hire & Service		✓		✓
Ramsay & Sons (Forfar) Limited		✓		✓
Rapid Racking Ltd		✓		✓
Redhill Manufacturing Ltd		✓		✓
REDWAY Bardsley		✓		✓
Rob-Ind UK		✓		✓
Roger Haydock & Co Ltd	✓			
Ronco Sales Organisation	✓			
ROSPA		✓		✓
S G B Youngman	✓			✓

Company	Letter Response		Telephone Response	
	YES	NO	YES	NO
SGB International		✓		✓
S G B Manufacturers		✓		✓
S M L (Worcester) Limited	✓			
Signet DIY		✓	✓	
Sinbad Tools		✓		✓
Smiths Equipment		✓		✓
Stiftung Warentest	✓			
Stinson Sales & Manufacturing		✓		✓
Stokes Ladders		✓		✓
Storage Solution		✓		✓
Surespan Ltd		✓		✓
T B Davies		✓		✓
T J Dobson		✓		✓
Tamms Direct Ltd		✓		✓
The Loft Centre Group Ltd		✓		✓
Timber abd Tile Products		✓		✓
Travis Perkins Tool Hire		✓		✓
Truscott (Storage & Partinioning) Ltd		✓		✓
U B M Tool Hire		✓		✓
Union Federale des Consommiters		✓		✓
Up a Loft		✓		✓
W H Hulley		✓		✓
W J Chow & Co Ltd		✓		✓
Wakefields Storage Handling		✓		✓
The Welconstruct Company		✓		✓
Werner Company		✓		✓
Wraight Handling Ltd				
Y C Youngman		✓		✓
Zarges UK Ltd		✓		✓



MAIL ORDER

HSE priced and free
publications are
available from:

HSE Books
PO Box 1999
Sudbury
Suffolk CO10 2WA
Tel: 01787 881165
Fax: 01787 313995
Website: www.hsebooks.co.uk

RETAIL

HSE priced publications
are available from booksellers

HEALTH AND SAFETY INFORMATION

HSE InfoLine
Tel: 08701 545500
Fax: 02920 859260
e-mail: hseinformationservices@natbrit.com
or write to:
HSE Information Services
Caerphilly Business Park
Caerphilly CF83 3GG

HSE website: www.hse.gov.uk

CRR 418

£15.00

ISBN 0-7176-2302-5

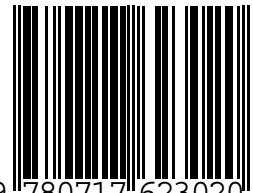

9 780717 623020