



CONVENTIONAL CRANE

180 TONS

AMERICAN 8470

BOOM LENGTHS:
40 TO 280 FT

JIB LENGTHS:
30 TO 60 FT

JIB OFFSETS:
0 - 15 - 30



NOTES:



8470 CARRIER SPECIFICATION

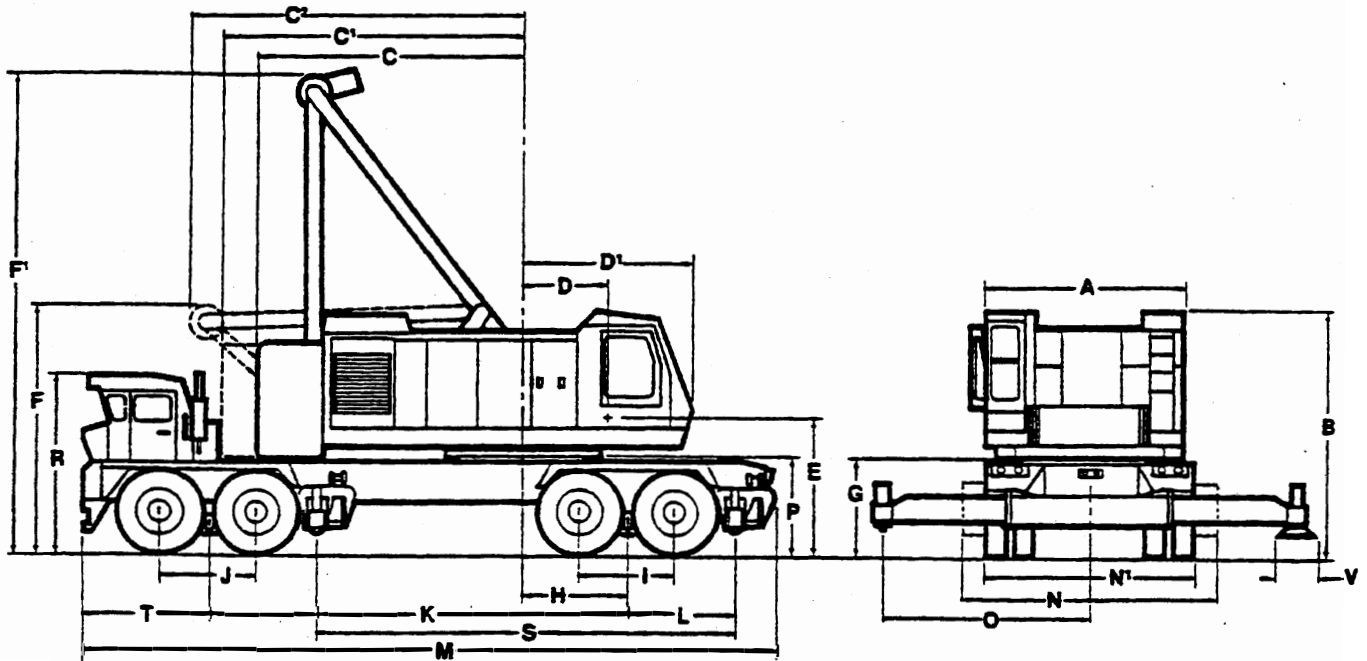

GENERAL DIMENSIONS

	FL	MM		FL	MM
A. Width of Cab.....	10'4"	3150 mm	L. Centerline of Rear Bogie to		
B. Height to Top of Cab	13'0"	3962 mm	Centerline of Rear Outrigger...	6'3¼"	1924 mm
C. Tailswing Over Cwt. Retracted ...	14'0"	4267 mm	M. Overall Length	36'1¼"	11004 mm
C ₁ . Tailswing Over Cwt. Extended ...	16'0"	4876 mm	N. Width Over Outriggers Retracted ..		3962 mm
C ₂ . Tailswing Over A-Frame			N ₁ . Width, Outriggers Removed	13'6"	3352 mm
Lowered	17'9½"	54223 mm	O. Centerline of Rotation to Centerline		
D. Centerline of Rotation to			of Outrigger Jack, Extended	12'0"	3657 mm
Centerline of Boom Foot	4'6"	1371 mm	P. Height Over Mounting Plate	5'0½"	1536 mm
D ₁ . Centerline of Rotation			R. Height Over Carrier Cab	9'4"	2845 mm
to Front of Cab	8'10¼"	2711 mm	S. Centerline of Rear Outrigger to		
E. Ground to Centerline			Centerline of Front Outrigger ...	22'0"	6705 mm
of Boom Foot	7'2¼"	2203 mm	T. Center of Rear Outrigger to		
F. Height Over A-Frame Lowered ...	13'2"	4013 mm	Rear of Carrier	1'7½"	495 mm
F ₁ . Height Over A-Frame Raised	25'2"	7670 mm	U. Distance from Front Bogie to		
G. Ground to Bottom of Cwt.	5'3½"	1613 mm	Front Bumper	6'2"	1879 mm
H. Centerline of Rotation to			V. Outrigger Float Diameter	3'6"	1066 mm
Centerline of Rear Bogie	5'6¼"	1682 mm	Turning Radius Over		
I. Distance Between Rear Axles	5'0"	1524 mm	Front Bumper	65'0"	19812 mm
J. Distance Between Front Axles	5'0"	1524 mm	Clearance Under Equalizing Beam ..	7½"	190 mm
K. Centerline of Rear Bogie to Centerline			Clearance Under Differential	12"	304 mm
of Front Bogie (Wheelbase).....	22'0"	6705 mm			



PORTLAND OFFICE: 503.283.3111
SEATTLE OFFICE: 206.784.1054

WWW.NESSCAMPBELL.COM

AMERICAN HOIST & DERRICK CO.
ST. PAUL, MINNESOTA 55107

MODEL 8470 TRUCK CRANE RATINGS IN POUNDS
77L TUBULAR BOOM W/TAPERED TIP
68,500 LBS EXTENDED CTWT.-13' WIDE
AMERICAN CARRIER

BOOM LENGTH (FEET)	RADIUS IN FEET	BOOM ANGLE DEGREES	OUTRIGGERS FREE		OUTRIGGERS SET		FEET FROM BOOM POINT TO GROUND
			OVER SIDE	OVER REAR	OVER SIDE & FRONT	OVER REAR	
80'	18	80.3		79,520*	176,410*	176,410*	86
	20	78.8		74,840*	176,410*	176,410*	86
	25	75.2		65,240*	160,780*	160,780*	85
	30	71.4		57,550*	133,880*	133,880*	83
	35	67.6		51,480*	114,800*	114,800*	81
	40	63.7		46,350*	100,400*	100,400*	79
	50	55.3		38,520*	76,150	79,480	73
	60	46.1	17,960*	31,540*	59,190	61,880	65
	70	35.0	14,640*	25,800*	48,000	50,260	53
80	19.3	12,090*	21,600*	40,090	42,050	34	
90'	19	80.7		76,190*	176,300*	176,300*	96
	20	80.1		73,930*	176,300*	176,300*	96
	25	76.8		64,390*	160,680*	160,680*	95
	30	73.5		56,750*	133,780*	133,780*	94
	35	70.2		50,730*	114,720*	114,720*	92
	40	66.8		45,630*	100,320*	100,320*	90
	50	59.6		37,870*	75,980	79,300	85
	60	51.9	17,490*	31,250*	59,010	61,700	78
	70	43.3	14,180*	25,510*	47,800	50,060	69
80	33.0	11,640*	21,290	39,870	41,820	56	
90	18.2	9,640*	18,080	33,990	35,700	35	
100'	21	80.5		70,940*	176,080*	176,080*	106
	25	78.2		63,600*	160,590*	160,590*	105
	30	75.2		56,000*	133,690*	133,690*	104
	35	72.2		50,020*	114,640*	114,640*	102
	40	69.2		44,950*	100,240*	100,240*	101
	50	62.9		37,250*	75,780	79,100	96
	60	56.3	17,020*	30,950*	58,800	61,490	90
	70	49.1	13,730*	25,210*	47,570	49,830	83
	80	41.0	11,200*	20,990	39,630	41,580	73
	90	31.2	9,200*	17,770	33,730	35,450	59
100	17.3	7,650*	15,300	29,240	30,770	37	
110'	22	80.8		67,980*	176,080*	176,080*	116
	25	79.3		62,700*	160,490*	160,490*	115
	30	76.6		55,140*	133,590*	133,590*	114
	35	73.9		49,210*	114,560*	114,560*	113
	40	71.2		44,170*	100,160*	100,160*	111
	50	65.6	20,740*	36,520*	75,510	78,820	107
	60	59.7	16,460*	30,580*	58,530	61,210	102
	70	53.5	13,190*	24,840	47,280	49,540	96
	80	46.7	10,680*	20,630	39,330	41,280	87
	90	39.0	8,690*	17,410	33,430	35,140	76
	100	29.8	7,180*	14,960	28,960	30,490	62
110	16.4	5,820*	12,880	25,300	26,670	38	



PORTLAND OFFICE: 503.283.3111
SEATTLE OFFICE: 206.784.1054

WWW.NESSCAMPBELL.COM

AMERICAN HOIST & DERRICK CO.
ST. PAUL, MINNESOTA 55107

MODEL 8470 TRUCK CRANE RATINGS IN POUNDS
77L TUBULAR BOOM W/TAPERED TIP
68,500 LBS EXTENDED CTWTS-13' WIDE
AMERICAN CARRIER

BOOM LENGTH (FEET)	RADIUS IN FEET	BOOM ANGLE DEGREES	OUTRIGGERS FREE		OUTRIGGERS SET		FEET FROM BOOM POINT TO GROUND
			OVER SIDE	OVER REAR	OVER SIDE & FRONT	OVER REAR	
120'	24	80.6		63,390*	166,900*	166,900*	126
	25	80.2		61,880*	160,400*	160,400*	125
	30	77.7		54,340*	133,500*	133,500*	125
	35	75.3		48,470*	114,490*	114,490*	123
	40	72.8		43,450*	100,090*	100,090*	122
	50	67.7	20,170*	35,850*	75,230	78,540	118
	60	62.5	15,920*	30,210*	58,250	60,930	114
	70	56.9	12,660*	24,470	46,980	49,230	108
	80	51.0	10,160*	20,260	39,020	40,970	101
	90	44.6	8,180*	17,030	33,110	34,810	91
	100	37.3	6,720*	14,630	28,670	30,200	80
	110	28.5	5,370*	12,540	25,010	26,380	64
120	15.7	4,240*	10,830	22,020	23,280	40	
130'	25	80.9		61,980*	160,300*	160,300*	136
	30	78.7		54,440*	133,400*	133,400*	135
	35	76.4		48,580*	114,410*	114,410*	134
	40	74.2		43,550*	100,010*	100,010*	132
	50	69.5	20,270*	35,960*	75,280	78,590	129
	60	64.7	16,050*	30,300*	58,320	61,000	125
	70	59.7	12,780*	24,550	47,050	49,310	120
	80	54.5	10,270*	20,330	39,090	41,040	113
	90	48.9	8,300*	17,110	33,180	34,890	105
	100	42.7	6,870*	14,740	28,770	30,300	95
	110	35.8	5,520*	12,660	25,120	26,490	83
	120	27.3	4,390*	10,940	22,130	23,350	67
130	15.1	3,420*	9,500	19,660	20,810	41	
140'	27	80.8		57,880*	148,250*	148,250*	145
	30	79.5		53,580*	133,310*	133,310*	145
	35	77.4		47,760*	114,330*	114,330*	144
	40	75.3		42,760*	99,930*	99,930*	143
	50	71.0	19,670*	35,250*	75,020	78,320	140
	60	66.6	15,480*	29,720*	58,030	60,720	136
	70	62.1	12,230*	24,170	46,750	49,010	131
	80	57.4	9,740*	19,960	38,780	40,730	125
	90	52.4	7,770*	16,730	32,850	34,560	118
	100	47.0	6,360*	14,380	28,460	29,990	110
	110	41.1	5,030*	12,300	24,810	26,180	99
	120	34.4	3,910*	10,580	21,820	23,070	86
130	26.3	2,960*	9,150	19,350	20,500	69	
140	14.6	2,110*	7,910	17,250	18,310	42	
150'	28	81.0			142,820*	142,820*	155
	30	80.2			133,210*	133,210*	155
	35	78.3			114,260*	114,260*	154
	40	76.3			99,860*	99,860*	153
	50	72.3			74,730	78,030	150
	60	68.3			57,740	60,420	147
70	64.1			46,440	48,700	142	



PORTLAND OFFICE: 503.283.3111
SEATTLE OFFICE: 206.784.1054
WWW.NESSCAMPBELL.COM

AMERICAN HOIST & DERRICK CO.
ST. PAUL, MINNESOTA 55107

MODEL 8470 TRUCK CRANE RATINGS IN POUNDS
77L TUBULAR BOOM W/TAPERED TIP
68,500 LBS EXTENDED CTWT.-13' WIDE
AMERICAN CARRIER

BOOM LENGTH (FEET)	RADIUS IN FEET	BOOM ANGLE DEGREES	OUTRIGGERS FREE		OUTRIGGERS SET		FEET FROM BOOM POINT TO GROUND
			OVER SIDE	OVER REAR	OVER SIDE & FRONT	OVER REAR	
150'	80	59.8			38,470	40,410	137
	90	55.2			32,530	34,240	130
	100	50.5			28,160	29,680	123
	110	45.3			24,490	25,860	114
	120	39.6			21,500	22,750	103
	130	33.2			19,030	20,170	89
	140	25.4			16,930	17,990	72
	150	14.1			15,140	16,130	44
160'	30	80.8			133,120*	133,120*	165
	35	79.0			114,180*	114,180*	164
	40	77.2			99,780*	99,780*	163
	50	73.5			74,420	77,720	161
	60	69.7			57,420	60,100	157
	70	65.8			46,110	48,360	153
	80	61.8			38,110	40,050	148
	90	57.7			32,410	34,120	142
	100	53.4			27,810	29,330	136
	110	48.7			24,150	25,520	128
	120	43.8			21,160	22,410	118
	130	38.3			18,670	19,820	106
140	32.1			16,570	17,630	92	
150	24.6			14,790	15,770	74	
160	13.6			13,240	14,150	45	
170'	32	80.7			124,920*	124,920*	175
	35	79.7			114,110*	114,110*	174
	40	77.9			99,710*	99,710*	174
	50	74.5			74,100	77,400	171
	60	70.9			57,100	59,770	168
	70	67.3			45,760	48,010	164
	80	63.6			37,760	39,700	160
	90	59.8			32,080	33,780	154
	100	55.8			27,470	28,990	148
	110	51.6			23,790	25,160	141
	120	47.2			20,810	22,050	132
	130	42.4			18,320	19,470	122
	140	37.1			16,220	17,280	110
150	31.1			14,430	15,410	95	
160	23.8			12,870	13,790	76	
170	13.2			11,530	12,390	46	
180'	33	80.9			100,890*	100,890*	185
	35	80.2			100,890*	100,890*	185
	40	78.6			99,630*	99,630*	184
	50	75.4			73,960	77,260	181
	60	72.0			56,990	59,660	178
	70	68.7			45,650	47,900	175
	80	65.2			37,650	39,590	171
90	61.6			32,000	33,700	166	



PORTLAND OFFICE: 503.283.3111
SEATTLE OFFICE: 206.784.1054
WWW.NESSCAMPBELL.COM

AMERICAN HOIST & DERRICK CO.
ST. PAUL, MINNESOTA 55107

MODEL 8470 TRUCK CRANE RATINGS IN POUNDS
77L TUBULAR BOOM W/TAPERED TIP
68,500 LBS EXTENDED CTWT.-13' WIDE
AMERICAN CARRIER

BOOM LENGTH (FEET)	RADIUS IN FEET	BOOM ANGLE DEGREES	OUTRIGGERS FREE		OUTRIGGERS SET		FEET FROM BOOM POINT TO GROUND
			OVER SIDE	OVER REAR	OVER SIDE & FRONT	OVER REAR	
180'	100	58.0			27,390	28,910	160
	110	54.1			23,720	25,090	153
	120	50.1			20,730	21,970	145
	130	45.8			18,240	19,390	136
	140	41.2			16,150	17,210	126
	150	36.1			14,350	15,340	113
	160	30.2			12,810	13,730	98
	170	23.2			11,460	12,320	78
	180	12.8			10,280	11,090	47
190'	35	80.8			93,740*	93,740*	195
	40	79.2			93,740*	93,740*	194
	50	76.1			73,680	76,980	192
	60	73.0			56,680	59,360	189
	70	69.8			45,340	47,590	186
	80	66.6			37,320	39,260	152
	90	63.3			31,670	33,380	177
	100	59.8			27,060	28,580	172
	110	56.3			23,390	24,750	165
	120	52.6			20,390	21,640	158
	130	48.7			17,900	19,050	150
	140	44.5			15,800	16,860	140
	150	40.0			14,000	14,990	129
160	35.1			12,460	13,380	116	
170	29.4			11,100	11,970	101	
180	22.5			9,920	10,730	80	
190	12.5			8,860	9,630	48	
200'	36	80.9			87,240*	87,240*	205
	40	79.8			87,240*	87,240*	204
	50	76.9			73,380	76,670	202
	60	73.9			56,370	59,040	199
	70	70.9			45,010	47,260	196
	80	67.8			36,980	38,920	192
	90	64.7			31,350	33,050	188
	100	61.5			26,720	28,230	183
	110	58.2			23,050	24,420	177
	120	54.7			20,050	21,290	171
	130	51.1			17,550	18,700	163
	140	47.4			15,460	16,510	154
	150	43.3			13,660	14,640	144
	160	39.0			12,110	13,030	133
	170	34.2			10,750	11,610	120
	180	28.7			9,550	10,370	103
190	22.0			8,500	9,270	82	
200	12.2			7,570	8,300	49	



PORTLAND OFFICE: 503.283.3111
SEATTLE OFFICE: 206.784.1054
WWW.NESSCAMPBELL.COM

AMERICAN HOIST & DERRICK CO.
ST. PAUL, MINNESOTA 55107

MODEL 8470 TRUCK CRANE RATINGS IN POUNDS
77L TUBULAR BOOM W/TAPERED TIP
68,500 LBS EXTENDED CTWT.-13' WIDE
AMERICAN CARRIER

BOOM LENGTH (FEET)	RADIUS IN FEET	BOOM ANGLE DEGREES	OUTRIGGERS FREE		OUTRIGGERS SET		FEET FROM: BOOM POINT TO GROUND
			OVER SIDE	OVER REAR	OVER SIDE & FRONT	OVER REAR	
210'	38	80.8			81,160*	81,160*	215
	40	80.3			81,160*	81,160*	214
	50	77.5			73,060	76,350	212
	60	74.7			56,060	58,730	210
	70	71.8			44,670	46,910	207
	80	68.9			36,620	38,560	203
	90	66.0			31,000	32,700	199
	100	63.0			26,360	27,880	194
	110	59.8			22,680	24,050	189
	120	56.6			19,690	20,930	183
	130	53.3			17,190	18,330	176
	140	49.8			15,080	16,140	168
	150	46.1			13,280	14,270	159
	160	42.2			11,730	12,650	148
	170	38.0			10,370	11,230	137
	180	33.3			9,180	9,990	123
	190	28.0			8,120	8,890	106
200	21.4			7,180	7,910	84	
210	11.9			6,340	7,030	50	
220'	39	81.0			75,450*	75,450*	225
	40	80.7			75,450*	75,450*	224
	50	78.1			72,750	74,780*	222
	60	75.4			55,730	58,390	220
	70	72.7			44,320	46,560	217
	80	69.9			36,260	38,190	214
	90	67.1			30,650	32,350	210
	100	64.3			26,010	27,520	205
	110	61.3			22,320	23,690	200
	120	58.3			19,310	20,560	194
	130	55.2			16,820	17,970	188
	140	52.0			14,710	15,770	181
	150	48.6			12,910	13,890	172
	160	45.0			11,350	12,270	163
170	41.2			9,990	10,850	152	
180	37.1			8,790	9,610	140	
190	32.5			7,740	8,500	126	
200	27.3			6,790	7,520	108	
210	20.9			5,950	6,640	86	
220	11.6			5,200	5,860	52	
230'	41	80.9			58,270*	58,270*	234
	50	78.6			57,490*	57,490*	233
	60	76.0			55,520	56,240*	230
	70	73.5			44,120	46,360	228
	80	70.8			36,070	38,000	225
	90	68.2			30,480	32,180	221
	100	65.5			25,840	27,360	216
110	62.7			22,160	23,520	212	



PORTLAND OFFICE: 503.283.3111
SEATTLE OFFICE: 206.784.1054
WWW.NESSCAMPBELL.COM

AMERICAN HOIST & DERRICK CO.
ST. PAUL, MINNESOTA 55107

MODEL 8470 TRUCK CRANE RATINGS IN POUNDS
77L TUBULAR BOOM W/TAPERED TIP
68,500 LBS EXTENDED CTWT.-13' WIDE
AMERICAN CARRIER

BOOM LENGTH (FEET)	RADIUS IN FEET	BOOM ANGLE DEGREES	OUTRIGGERS FREE		OUTRIGGERS SET		FEET FROM BOOM POINT TO GROUND
			OVER SIDE	OVER REAR	OVER SIDE & FRONT	OVER REAR	
230'	120	59.9			19,150	20,400	206
	130	56.9			16,660	17,800	200
	140	53.9			14,560	15,610	193
	150	50.8			12,750	13,740	185
	160	47.5			11,200	12,120	177
	170	44.0			9,830	10,700	167
	180	40.3			8,650	9,460	156
	190	36.2			7,580	8,350	143
	200	31.8			6,640	7,370	128
	210	26.7			5,790	6,480	111
	220	20.5			5,030	5,690	88
230	11.4			4,360	4,990	53	
240'	43	80.8			54,870*	54,870*	244
	50	79.1			54,250*	54,250*	243
	60	76.6			52,870*	52,870*	241
	70	74.2			43,790	46,030	238
	80	71.7			35,730	37,660	235
	90	69.1			30,150	31,850	232
	100	66.6			25,510	27,020	227
	110	63.9			21,810	23,180	223
	120	61.2			18,810	20,050	218
	130	58.5			16,310	17,450	212
	140	55.6			14,190	15,250	205
	150	52.7			12,400	13,380	198
	160	49.6			10,830	11,750	190
	170	46.4			9,480	10,340	181
	180	43.0			8,280	9,090	171
	190	39.4			7,220	7,950	160
	200	35.5			6,270	6,990	146
210	31.1			5,420	6,110	131	
220	26.1			4,650	5,310	113	
230	20.0			3,970	4,600	89	
240	11.1			3,350	3,950	54	
250'	44	80.9			51,530*	51,530*	254
	50	79.5			51,110*	51,110*	253
	60	77.2			49,630*	49,630*	251
	70	74.8			43,460	45,700	249
	80	72.4			35,390	37,310	246
	90	70.0			29,820	31,510	242
	100	67.5			25,170	26,680	238
	110	65.0			21,470	22,830	234
	120	62.5			18,460	19,700	229
	130	59.9			15,950	17,100	223
	140	57.2			13,840	14,900	217
150	54.4			12,030	13,010	211	
160	51.5			10,480	11,390	203	
170	48.5			9,110	9,970	195	



PORTLAND OFFICE: 503.283.3111
SEATTLE OFFICE: 206.784.1054
WWW.NESSCAMPBELL.COM

BOOM LENGTH (FEET)	RADIUS IN FEET	BOOM ANGLE DEGREES	OUTRIGGERS FREE		OUTRIGGERS SET		FEET FROM BOOM POINT TO GROUND
			OVER SIDE	OVER REAR	OVER SIDE & FRONT	OVER REAR	
250'	180	45.4			7,910	8,720	185
	190	42.1			6,850	7,610	175
	200	38.6			5,900	6,620	163
	210	34.7			5,050	5,740	150
	220	30.5			4,290	4,950	134
	230	25.6			3,590	4,220	115
	240	19.6			2,960	3,560	91
	250	10.9			2,410	2,980	54
260'	46	80.8			48,590*	48,590*	264
	50	79.9			48,190*	48,190*	263
	60	77.7			47,030*	47,030*	261
	70	75.4			43,680	45,460*	259
	80	73.1			35,590	37,520	256
	90	70.8			30,040	31,730	253
	100	68.5			25,380	26,890	249
	110	66.1			21,670	23,040	245
	120	63.6			18,660	19,900	240
	130	61.1			16,150	17,290	235
	140	58.6			14,030	15,090	229
	150	56.0			12,220	13,200	223
	160	53.3			10,660	11,570	216
	170	50.5			9,300	10,160	208
	180	47.5			8,100	8,910	199
	190	44.5			7,030	7,790	189
	200	41.2			6,080	6,800	179
	210	37.8			5,230	5,920	167
220	34.0			4,460	5,110	153	
230	29.9			3,760	4,390	137	
240	25.1			3,140	3,740	117	
250	19.2			2,560	3,140	93	
260	10.7			2,050	2,610	55	
270'	47	80.9			45,680*	45,680*	274
	50	80.3			45,360*	45,360*	273
	60	78.1			44,050*	44,050*	271
	70	76.0			42,480*	42,480*	269
	80	73.8			35,240	37,170	266
	90	71.5			29,690	31,380	263
	100	69.3			25,020	26,530	260
	110	67.0			21,310	22,670	256
	120	64.7			18,290	19,530	251
	130	62.3			15,780	16,920	246
	140	59.9			13,660	14,720	241
	150	57.4			11,850	12,830	235
	160	54.8			10,280	11,200	228
	170	52.2			8,920	9,780	221
180	49.5			7,710	8,520	212	
190	46.6			6,650	7,410	203	



PORTLAND OFFICE: 503.283.3111
SEATTLE OFFICE: 206.784.1054
WWW.NESSCAMPBELL.COM

AMERICAN HOIST & DERRICK CO.
ST. PAUL, MINNESOTA 55107

MODEL 8470 TRUCK CRANE RATINGS IN POUNDS
77L TUBULAR BOOM W/TAPERED TIP
68,500 LBS EXTENDED CIWT.-13' WIDE
AMERICAN CARRIER

BOOM LENGTH (FEET)	RADIUS IN FEET	BOOM ANGLE DEGREES	OUTRIGGERS FREE		OUTRIGGERS SET		FEET FROM BOOM POINT TO GROUND
			OVER SIDE	OVER REAR	OVER SIDE & FRONT	OVER REAR	
270'	200	43.6			5,700	6,420	193
	210	40.4			4,840	5,530	182
	220	37.0			4,070	4,730	170
	230	33.4			3,380	4,000	156
	240	29.3			2,740	3,340	139
	250	24.6			2,160	2,740	120
	260	18.9			1,650	2,200	95
	270	10.5			1,180	1,710	56
280'	49	80.9			36,530*	36,530*	284
	50	80.6			36,310*	36,310*	284
	60	78.6			35,230*	35,230*	252
	70	76.5			33,770*	33,770*	279
	80	74.4			31,120*	31,120*	277
	90	72.2			29,460	29,910*	274
	100	70.1			24,800	26,310	270
	110	67.9			21,100	22,460	267
	120	65.6			18,080	19,320	262
	130	63.4			15,570	16,710	252
	140	61.1			13,450	14,510	252
	150	58.7			11,640	12,620	246
	160	56.3			10,080	10,990	240
	170	53.8			8,710	9,570	233
	180	51.2			7,510	8,320	225
	190	48.5			6,440	7,200	217
	200	45.7			5,490	6,220	208
	210	42.8			4,640	5,330	197
	220	39.7			3,860	4,520	186
	230	36.4			3,160	3,790	173
240	32.7			2,530	3,130	159	
250	28.7			1,950	2,530	142	
260	24.1			1,430	1,980	122	
270	18.5				1,490	96	

These ratings comply with ANSI B30.5 Code. They are applicable only when the crane is used in accordance with good operating practice, including the limitations shown on page 3499 of the operator's manual.

Ratings are in pounds and do not exceed 85% of the load which would cause tipping at the given radii, with crane standing level on a firm uniformly supporting surface.

Tire inflation pressure for "Free Ratings" and up to 1 MPH is 130 psi front bogie and 95 psi rear bogie. Tire pressure should be reduced for over-the-road travel. See operating manual for recommended tire loading and tire pressure for travel speeds above 1 MPH.

Lifting over front requires front outriggers set.



PORTLAND OFFICE: 503.283.3111
SEATTLE OFFICE: 206.784.1054
WWW.NESSCAMPBELL.COM

BOOM LENGTH (FEET)	RADIUS IN FEET	BOOM ANGLE DEGREES	OUTRIGGERS FREE		OUTRIGGERS SET		FEET FROM BOOM POINT TO GROUND
			OVER SIDE	OVER REAR	OVER SIDE & FRONT	OVER REAR	
50'	12	84.3		95,410*	360,000*	360,000*	58
	13	83.1		91,940*	357,600*	360,000*	58
	14	82.0		89,140*	326,220*	326,220*	58
	15	80.8		86,020*	317,410*	317,410*	58
	20	75.0		73,130*	238,040*	238,040*	57
	25	69.0		63,320*	190,480*	190,480*	55
	30	62.8		55,520*	158,750*	158,750*	53
	35	56.0		49,220*	126,530	131,630	50
	40	48.7	26,050*	43,950*	102,340	106,680	46
50	29.7	19,330*	35,780*	73,030	76,370	33	
60'	13	84.3		90,970*	355,970*	360,000*	68
	15	82.4		85,100*	317,230*	317,230*	68
	20	77.6		72,320*	237,880*	237,880*	67
	25	72.6		62,620*	190,360*	190,360*	65
	30	67.6		54,900*	158,650*	158,650*	64
	35	62.3		48,670*	126,790	131,870	61
	40	56.7	25,740*	43,440*	102,530	106,860	58
	50	44.1	19,100*	35,370*	73,200	76,530	50
60	26.9	14,440*	28,500	56,030	58,730	35	
70'	14	84.3		86,730*	335,990*	339,650*	78
	16	82.6		81,310*	297,150*	297,150*	78
	20	79.3		71,530*	237,730*	237,730*	77
	25	75.2		61,910*	190,240*	190,240*	76
	30	70.9		54,270*	158,550*	158,550*	74
	35	66.5		48,090*	126,890	131,970	72
	40	62.0	25,360*	42,900*	102,580	106,910	70
	50	52.1	18,800*	34,920*	73,230	76,560	63
	60	40.6	14,220*	28,440	56,090	58,780	53
70	24.7	10,760*	22,570	44,750	47,010	37	
80'	17	82.8		77,740*	279,550*	279,550*	86
	20	80.7		70,610*	237,580*	237,580*	87
	25	77.1		61,090*	190,130*	190,130*	86
	30	73.4		53,490*	158,450*	158,450*	85
	35	69.6	29,380*	47,380*	126,860	131,940	83
	40	65.7	24,840*	42,220*	102,510	106,830	81
	50	57.6	18,330*	34,310*	73,120	76,440	76
	60	48.5	13,820*	28,220	55,980	58,670	68
	70	37.8	10,400*	22,370	44,650	46,910	57
	80	23.0	7,740*	18,050	36,610	38,560	39
90'	18	83.0		74,280*	263,790*	263,790*	98
	20	81.7		69,750*	237,430*	237,430*	97
	25	78.5		60,310*	190,020*	190,020*	96
	30	75.3		52,770*	158,360*	158,360*	95
	35	71.9	28,850*	46,700*	126,800	131,860	94
	40	68.6	24,320*	41,560*	102,380	106,700	92
	50	61.5	17,860*	33,730*	72,970	76,280	87
	60	54.0	13,400*	27,920*	55,820	58,510	81



PORTLAND OFFICE: 503.283.3111
SEATTLE OFFICE: 206.784.1054
WWW.NESSCAMPBELL.COM

AMERICAN HOIST & DERRICK CO.
ST. PAUL, MINNESOTA 55107

MODEL 8470 TRUCK CRANE RATINGS IN POUNDS
77L TUBULAR BOOM W/HAMMERHEAD TIP
68,500 LBS EXTENDED CTWT.-13' WIDE
AMERICAN CARRIER

BOOM LENGTH (FEET)	RADIUS IN FEET	BOOM ANGLE DEGREES	OUTRIGGERS FREE		OUTRIGGERS SET		FEET FROM BOOM POINT TO GROUND	
			OVER SIDE	OVER REAR	OVER SIDE & FRONT	OVER REAR		
90'	70	45.5	10,000*	22,120*	44,480	46,740	72	
	80	35.5	7,390*	17,830	36,460	38,400	60	
	90	21.6	5,350*	14,570	30,520	32,230	41	
100'	20	82.5		69,900*	236,630*	236,630*	107	
	25	79.7		60,490*	189,900*	189,900*	107	
	30	76.8		52,980*	158,260*	158,260*	106	
	35	73.8	29,110*	46,940*	127,050	132,120	104	
	40	70.8	24,580*	41,800*	102,640	106,950	103	
	50	64.6	18,140*	33,990*	73,230	76,540	98	
	60	58.0	13,720*	28,230*	56,120	58,810	93	
	70	51.0	10,330*	22,410	44,780	47,040	86	
	80	43.0	7,740*	18,120	36,770	38,710	76	
	90	33.6	5,770*	14,940	30,900	32,610	63	
	100	20.4	4,030*	12,280	26,220	27,740	42	
110'	21	82.7		67,000*	222,990*	222,990*	117	
	25	80.6		59,620*	189,790*	189,790*	117	
	30	78.0		52,170*	158,170*	158,170*	116	
	35	75.3	28,490*	46,170*	126,940	132,000	115	
	40	72.6	23,980*	41,060*	102,470	106,780	113	
	50	67.1	17,590*	33,310*	73,020	76,330	109	
	60	61.3	13,220*	27,610*	55,910	58,590	105	
	70	55.1	9,850*	22,090	44,550	46,810	98	
	80	48.4	7,270*	17,810	36,520	38,470	90	
	90	40.9	5,350*	14,660	30,680	32,350	80	
		100	31.9	3,650*	12,030	26,020	27,550	66
	110	19.4	2,220*	9,880	22,290	23,670	44	
120'	22	82.8		64,120*	212,010*	212,010*	127	
	25	81.4		58,820*	189,680*	189,680*	127	
	30	79.0	33,490*	51,400*	158,070*	158,070*	126	
	35	76.5	27,910*	45,450*	126,790	131,850	125	
	40	74.1	23,410*	40,360*	102,280	106,580	124	
	50	69.1	17,060*	32,670*	72,800	76,100	120	
	60	63.8	12,710*	27,000*	55,660	58,340	116	
	70	58.4	9,360*	21,760	44,290	46,550	110	
	80	52.5	6,800*	17,480	36,260	38,200	103	
	90	46.2	4,920*	14,360	30,440	32,150	95	
		100	39.0	3,250*	11,750	25,790	27,310	83
		110	30.5	1,850*	9,620	22,080	23,450	69
	120	18.5	640*	7,830	19,030	20,280	46	
130'	23	82.9		61,260*	200,230*	200,230*	137	
	25	82.1		57,920*	189,570*	189,570*	137	
	30	79.8	32,810*	50,560*	157,980*	157,980*	136	
	35	77.6	27,270*	44,650*	126,630	131,680	135	
	40	75.3	22,780*	39,590*	102,070	106,360	134	
	50	70.7	16,460*	31,950*	72,530	75,840	131	
	60	66.0	12,150*	26,340*	55,390	58,070	127	
	70	61.1	8,820*	21,390	44,000	46,250	122	



PORTLAND OFFICE: 503.283.3111
SEATTLE OFFICE: 206.784.1054
WWW.NESSCAMPBELL.COM

BOOM LENGTH (FEET)	RADIUS IN FEET	BOOM ANGLE DEGREES	OUTRIGGERS FREE		OUTRIGGERS SET		FEET FROM BOOM POINT TO GROUND
			OVER SIDE	OVER REAR	OVER SIDE & FRONT	OVER REAR	
130'	80	55.9	6,260*	17,100	35,950	37,890	116
	90	50.3	4,420*	14,010	30,140	31,850	108
	100	44.3	2,760*	11,400	25,500	27,020	99
	110	37.4	1,380*	9,280	21,780	23,160	87
	120	29.2		7,510	18,750	20,000	71
	130	17.8		6,020	16,220	17,360	47
140'	25	82.6		57,090*	184,850*	184,850*	147
	30	80.6	32,160*	49,770*	157,880*	157,880*	146
	35	78.5	26,650*	43,910*	126,440	131,480	145
	40	76.4	22,170*	38,860*	101,830	106,120	144
	50	72.2	15,900*	31,280*	72,270	75,570	141
	60	67.8	11,610*	25,710*	55,100	57,780	138
	70	63.3	8,290*	21,020	43,700	45,950	133
	80	58.6	5,740*	16,730	35,640	37,580	128
	90	53.7	3,940*	13,660	29,850	31,550	121
	100	48.4	2,290*	11,060	25,200	26,720	113
	110	42.6	910*	8,930	21,480	22,860	103
	120	36.0		7,180	18,460	19,710	90
	130	28.1			15,930	17,080	74
	140	17.1			13,780	14,840	49
150'	26	82.7			144,050*	144,050*	157
	30	81.2			142,380*	142,380*	156
	35	79.3			126,390	131,430	156
	40	77.3			101,770	106,070	155
	50	73.4			72,230	75,530	152
	60	69.4			55,090	57,760	149
	70	65.2			43,680	45,930	144
	80	60.9			35,630	37,570	139
	90	56.4			29,860	31,570	133
	100	51.7			25,210	26,740	126
	110	46.6			21,510	22,890	117
	120	41.0			18,490	19,740	106
	130	34.7			15,970	17,120	93
	140	27.1			13,830	14,900	76
150	16.5			12,000	12,990	50	
160'	27	82.8			133,140*	133,140*	167
	30	81.7			133,140*	133,140*	167
	35	79.9			126,230	131,260	166
	40	78.1			101,560	105,850	165
	50	74.4			71,970	75,270	162
	60	70.7			54,820	57,490	159
	70	66.9			43,390	45,640	155
	80	62.9			35,310	37,250	151
	90	58.8			29,570	31,270	145
	100	54.5			24,910	26,430	138
	110	49.9			21,200	22,570	130
	120	45.0			18,180	19,430	121



PORTLAND OFFICE: 503.283.3111
SEATTLE OFFICE: 206.784.1054
WWW.NESSCAMPBELL.COM

AMERICAN HOIST & DERRICK CO.
ST. PAUL, MINNESOTA 55107

MODEL 8470 TRUCK CRANE RATINGS IN POUNDS
77L TUBULAR BOOM W/HAMMERHEAD TIP
68,500 LBS EXTENDED CTWT.-13' WIDE
AMERICAN CARRIER

BOOM LENGTH (FEET)	RADIUS IN FEET	BOOM ANGLE DEGREES	OUTRIGGERS FREE		OUTRIGGERS SET		FEET FROM BOOM POINT TO GROUND
			OVER SIDE	OVER REAR	OVER SIDE & FRONT	OVER REAR	
160'	130	39.7			15,660	16,810	110
	140	33.6			13,530	14,590	96
	150	26.2			11,700	12,690	78
	160	15.9			10,110	11,040	51
170'	28	82.9			121,630*	121,630*	177
	30	82.2			121,630*	121,630*	177
	35	80.5			121,630*	121,630*	176
	40	78.8			101,330	105,610	175
	50	75.4			71,710	75,000	173
	60	71.9			54,540	57,210	170
	70	68.3			43,090	45,340	166
	80	64.6			35,000	36,940	162
	90	60.8			29,260	30,960	157
	100	56.9			24,610	26,130	150
	110	52.7			20,890	22,260	143
	120	48.3			17,860	19,110	135
	130	43.6			15,340	16,490	125
	140	38.4			13,210	14,270	113
150	32.5			11,390	12,380	99	
160	25.4			9,800	10,720	81	
170	15.4			8,420	9,290	53	
180'	29	83.0			111,840*	111,840*	187
	30	82.7			111,840*	111,840*	187
	35	81.1			111,840*	111,840*	186
	40	79.5			101,100	105,380	185
	50	76.2			71,420	74,720	183
	60	72.9			54,250	56,920	180
	70	69.6			42,770	45,020	177
	80	66.1			34,670	36,600	173
	90	62.6			28,930	30,640	168
	100	58.9			24,270	25,780	162
	110	55.1			20,560	21,930	156
	120	51.1			17,520	18,770	148
	130	46.9			15,000	16,150	139
	140	42.3			12,860	13,920	129
150	37.3			11,050	12,030	117	
160	31.6			9,460	10,380	102	
170	24.7			8,080	8,940	83	
180	14.9			6,850	7,660	54	
190'	31	82.8			103,020*	103,020*	197
	35	81.5			103,020*	103,020*	196
	40	80.0			100,850	103,020*	195
	50	76.9			71,140	74,430	193
	60	73.8			53,940	56,610	191
	70	70.7			42,450	44,690	187
	80	67.4			34,330	36,260	184
	90	64.1			28,610	30,310	179



PORTLAND OFFICE: 503.283.3111
SEATTLE OFFICE: 206.784.1054
WWW.NESSCAMPBELL.COM

AMERICAN HOIST & DERRICK CO.
ST. PAUL, MINNESOTA 55107

MODEL 8470 TRUCK CRANE RATINGS IN POUNDS
77L TUBULAR BOOM W/HAMMERHEAD TIP
68,500 LBS EXTENDED CTWT.-13' WIDE
AMERICAN CARRIER

BOOM LENGTH (FEET)	RADIUS IN FEET	BOOM ANGLE DEGREES	OUTRIGGERS FREE		OUTRIGGERS SET		FEET FROM BOOM POINT TO GROUND
			OVER SIDE	OVER REAR	OVER SIDE & FRONT	OVER REAR	
190'	100	60.7			23,930	25,450	174
	110	57.2			20,210	21,580	168
	120	53.5			17,180	18,430	161
	130	49.7			14,650	15,800	153
	140	45.5			12,520	13,580	144
	150	41.1			10,700	11,680	133
	160	36.2			9,110	10,030	120
	170	30.7			7,730	8,600	105
	180	24.0			6,520	7,330	85
	190	14.5			5,420	6,190	55
200'	32	82.8			78,400*	78,400*	207
	35	82.0			78,400*	78,400*	206
	40	80.5			78,400*	78,400*	206
	50	77.6			70,970	74,260	204
	60	74.7			53,800	56,470	201
	70	71.7			42,310	44,550	198
	80	68.6			34,190	36,130	194
	90	65.5			28,490	30,190	190
	100	62.3			23,820	25,340	185
	110	59.0			20,100	21,470	180
	120	55.6			17,060	18,310	173
	130	52.1			14,550	15,690	166
	140	48.3			12,410	13,470	157
	150	44.3			10,590	11,580	148
160	40.0			9,010	9,930	136	
170	35.3			7,640	8,500	123	
180	29.9			6,420	7,230	107	
190	23.3			5,340	6,110	87	
200	14.1			4,370	5,100	56	
210	33	82.9			73,670*	73,670*	217
	35	82.3			73,670*	73,670*	216
	40	81.0			73,670*	73,670*	216
	50	78.2			70,710	72,950*	214
	60	75.4			53,520	56,180	211
	70	72.6			42,000	44,240	209
	80	69.7			33,870	35,800	205
	90	66.8			28,180	29,880	201
	100	63.7			23,500	25,020	196
	110	60.7			19,770	21,140	191
	120	57.5			16,730	17,980	185
	130	54.2			14,210	15,350	178
	140	50.7			12,080	13,140	171
	150	47.1			10,250	11,230	162
160	43.2			8,670	9,590	152	



PORTLAND OFFICE: 503.283.3111
SEATTLE OFFICE: 206.784.1054
WWW.NESSCAMPBELL.COM

AMERICAN HOIST & DERRICK CO.
ST. PAUL, MINNESOTA 55107

MODEL 8470 TRUCK CRANE RATINGS IN POUNDS
77L TUBULAR BOOM W/HAMMERHEAD TIP
68,500 LBS EXTENDED CTWT.-13' WIDE
AMERICAN CARRIER

BOOM LENGTH (FEET)	RADIUS IN FEET	BOOM ANGLE DEGREES	OUTRIGGERS FREE		OUTRIGGERS SET		FEET FROM BOOM POINT TO GROUND
			OVER SIDE	OVER REAR	OVER SIDE & FRONT	OVER REAR	
210'	170	39.0			7,290	8,150	140
	180	34.4			6,080	6,890	126
	190	29.1			5,000	5,760	110
	200	22.8			4,030	4,760	89
	210	13.8			3,160	3,860	58
220'	34	83.0			68,990*	68,990*	227
	35	82.7			68,920*	68,920*	226
	40	81.4			68,920*	68,920*	226
	50	78.7			67,960*	67,960*	224
	60	76.1			53,230	55,890	222
	70	73.4			41,690	43,930	219
	80	70.7			33,550	35,480	216
	90	67.9			27,870	29,560	212
	100	65.0			23,180	24,690	208
	110	62.1			19,450	20,810	203
	120	59.1			16,400	17,650	197
	130	56.0			13,870	15,010	191
	140	52.8			11,730	12,790	183
	150	49.5			9,910	10,890	175
	160	45.9			8,330	9,250	166
	170	42.1			6,950	7,810	156
	180	38.1			5,730	6,540	143
190	33.6			4,640	5,410	129	
200	28.4			3,690	4,410	112	
210	22.2			2,820	3,510	91	
220	13.5			2,030	2,690	59	
230'	36	82.8			63,190*	63,190*	236
	40	81.8			63,150*	63,150*	236
	50	79.2			62,230*	62,230*	234
	60	76.7			52,930	55,590	232
	70	74.1			41,370	43,610	229
	80	71.5			33,210	35,140	226
	90	68.9			27,530	29,230	223
	100	66.2			22,840	24,350	219
	110	63.4			19,100	20,470	214
	120	60.6			16,050	17,300	209
	130	57.7			13,520	14,660	202
	140	54.7			11,380	12,430	196
	150	51.6			9,550	10,530	188
	160	48.3			7,960	8,880	180
	170	44.8			6,580	7,440	170
180	41.2			5,360	6,170	159	
190	37.2			4,280	5,040	147	
200	32.8			3,310	4,040	132	
210	27.8			2,440	3,130	115	
220	21.7			1,660	2,320	93	
230	13.1				1,580	60	



PORTLAND OFFICE: 503.283.3111
SEATTLE OFFICE: 206.784.1054
WWW.NESSCAMPBELL.COM

CRANE SERIAL NUMBER FOR THIS SHEET: 8009A-02933
 SN: 8009A-02933
 SN: 8009A-02933

BOOM LENGTH FEET	LOAD RADII FEET	BOOM ANGLE DEGREES	STATIC CONDITIONS		P-RIBBING		DIST. FROM BOOM POINT FEET
			SIDE RISE FEET	OVER BEAM FEET	OVER BEAM FEET	OVER BEAM FEET	
25	80.9	80.9	114.410	114.410	114.410	114.410	136
30	78.7	78.7	114.410	114.410	114.410	114.410	135
35	76.4	76.4	114.410	114.410	114.410	92.400	134
40	74.2	74.2	100.010	100.010	100.010	78.030	132
45	69.5	69.5	75.280	75.280	75.280	65.060	129
50	64.7	64.7	58.130	58.130	58.130	43.450	126
55	60.0	60.0	47.050	47.050	47.050	34.780	123
60	54.5	54.5	29.090	29.090	29.090	24.820	113
65	48.9	48.9	31.180	31.180	31.180	24.280	109
70	42.7	42.7	28.770	28.770	28.770	20.710	95
75	35.8	35.8	25.120	25.120	25.120	17.850	83
80	27.3	27.3	22.130	22.130	22.130	15.270	67
85	15.1	15.1	18.560	18.560	18.560	13.850	41
27	81	81	114.330	114.330	114.330	114.330	145
30	79.5	79.5	114.330	114.330	114.330	114.330	145
35	77.4	77.4	114.330	114.330	114.330	92.200	144
40	75.3	75.3	99.930	99.930	99.930	78.810	143
45	71	71	75.020	75.020	75.020	58.420	140
50	66.8	66.8	58.020	58.020	58.020	43.120	136
55	62.1	62.1	46.750	46.750	46.750	34.420	131
60	57.4	57.4	35.780	35.780	35.780	28.540	125
65	52.4	52.4	32.650	32.650	32.650	23.950	118
70	47	47	28.460	28.460	28.460	20.400	110
75	41.1	41.1	24.810	24.810	24.810	17.570	99
80	34.4	34.4	21.830	21.830	21.830	15.250	65
85	28.3	28.3	19.350	19.350	19.350	13.340	69
90	14.5	14.5	17.250	17.250	17.250	11.710	42

ABBREVIATED CRANE CHARTS FOR USE WITH ROLLING OUTRIGGERS

CHART IS DERIVED FROM PUBLISHED AMHOIST CHARTS. STATIC CONDITIONS IS DERIVED FROM 8500 POUND ROLLING COUNTERWEIGHT. ROLLING CONDITIONS IS DERIVED FROM 5000 POUND ROLLING COUNTERWEIGHT.

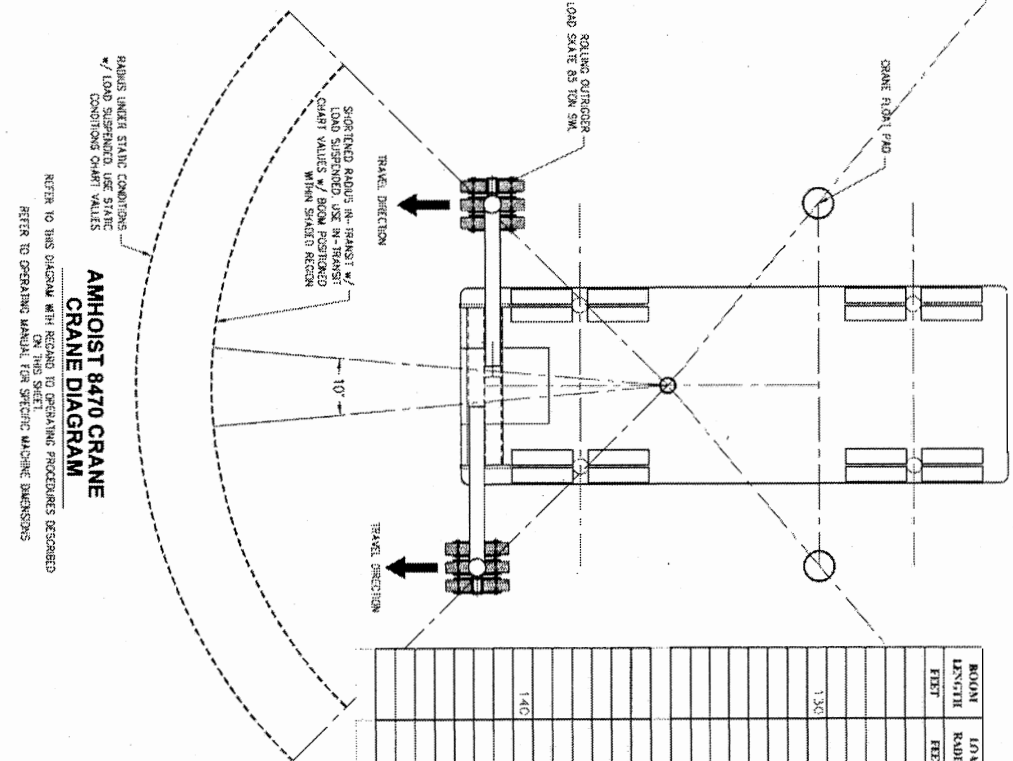

AMHOIST 8470 CRANE CRANE DIAGRAM

BOOM SHEET STAIN CONDITIONS. *LOADS MUST BE USED WITH CONDITIONS CHART VALUES. REFER TO THIS CHART WITH REGARD TO OPERATING PROCEDURES DESCRIBED ON THIS SHEET. REFER TO OPERATING MANUAL FOR SPECIFIC MACHINE DIMENSIONS.

INCORPORATED CONSULTING ENGINEERS
 811 First Avenue, Suite 1300
 Seattle, WA 98101
 Phone: 206-461-1100
 Fax: 206-461-1188
 Email: info@nesscambell.com

PRO: INCORPORATED IS NOT RESPONSIBLE FOR SAFETY PROCEDURES, METHODS OR PROCEDURES OF OPERATION, OR THE CONSTRUCTION OF THE DESIGN, SHOWING OR THESE DIMENSIONS. THESE SPECIFICATIONS ARE GENERAL, OR NOT CALLED OUT. THE SPECIFICATIONS SHALL COMPLY TO STANDARDS OF THE AMERICAN SOCIETY OF MECHANICAL ENGINEERS (ASME) AND ARE NOT INTENDED FOR DESIGN. NO DESIGNER'S APPROVAL FROM PAD DIMENSIONS ARE ALSO NOT TO BE USED IN ANY MANNER THAT WOULD CONSTITUTE A DETRIMENT TO THE DESIGN OR INTEGRITY TO PAD.



AMERICAN HOIST & RIGGING TRUCK CRANE WITH 68,500 POUND COUNTERWEIGHT (SEE SHEET 2 OF 3 AND 3 OF 3 THESE SHEETS APPLY ONLY TO THE MACHINES WITH SERIAL NUMBERS LISTED IN THE TITLE BLOCK)

- GENERAL LIFT PLANNING / PROCEDURES WHEN USING ROLLING OUTRIGGERS**
- THE SUSPENDED LOAD SHALL BE A MAXIMUM OF 114,000 POUNDS
 MAXIMUM BOOM LENGTH SHALL BE 140 FEET
- GENERALIZATION OF THE PAD TO THE PROJECT SITE. THE WORK SCENARIO FOR LIFTING AND SETTING OF THE LOADS SHOULD BE REVIEWED BY NESS CAMPBELL. A SPECIFIC JOB HAZARD ANALYSIS (JHA) SHALL BE DEVELOPED TO IDENTIFY THE INITIAL RISK (DIRECTION), FINAL SETTING POSITION(S) AND THE OPERATING LOAD/RISKS FOR EACH POSITION. BEARING CAPACITY FOR THE CRANE SHALL BE DETERMINED IN ADVANCE TO SUPPORT OPERATIONS TO OPERATIONS. CONCRETE SHALL BE PLACED IN ADVANCE TO SUPPORT OPERATIONS TO OPERATIONS. IF NESS CRANE IS RESPONSIBLE FOR THE FOUNDATION, COORDINATE WITH NESS MANAGEMENT TO ASSESS FOUNDATION RISKS.
- TRAVEL PATH CONSIDERATION**
- SET-UP CRANE ON FIRM, SMOOTH, UNIFORM SUPPORT SURFACE SUCH AS CONCRETE OR STEEL PLATES.
 - THE CRANE SHALL BE LEVEL TO THE LONGITUDINAL AND TRANSVERSE AXES.
 - THE CRANE TRAVEL PATH SHALL BE CLEAR OF ALL OBSTACLES THAT WILL IMPAIR ROLLING OF CRANE.

- CRANE SETUP**
- SMACK WELDED BUSH TO WORKING POSITION OVER REAR OPERATING OVERLAY.
 - REMOVE FRONT AND REAR OUTRIGGER BEAMS TO MAXIMUM EXTENSION LIMIT.
 - ATTACH ROLLING OUTRIGGER ASSEMBLIES TO THE EXTENDED CYLINDER PINS.
 - SECURE ROLLING OUTRIGGER YAMK SYSTEMS AND CLAMP TIGHT.
 - EXTEND REAR OUTRIGGER BEAM CYLINDERS UNTIL WHEELS ON ROLLING OUTRIGGER ASSEMBLY CONTACT FOUNDATION.
 - EXTEND FRONT EXTENSION UNTIL THE TOP PLATE OF THE TELESCOPING BOX BEAM CONTACTS THE REAR. TOP PLATE OF FIXED REAR OUTRIGGER BOX-BEAM.
 - EXTEND THE CYLINDERS AN ADDITIONAL 1/2" (FIELD) REAR BOX-BEAMS AND MAINTAIN WHEEL CONTACT.
 - INFLATE TIRES TO 100-120 PSI.
 - WORK WITH THE STATIC CONDITIONS CHART COLUMN, LIFT THE SUSPENDED LOAD, AND SWING TO THE FULL COUNTERWEIGHT WITH 5' OF EXTENSION.

- CRANE USE DURING TRANSIT USING ROLLING OUTRIGGERS**
- CLEAR NON-ESSENTIAL PERSONNEL FROM THE CRANE TRAVEL PATH AND UNDER THE BOOM.
 - CRANE OPERATOR SHALL BE SEATED IN THE OPERATOR'S CAB.
 - CRANE OPERATOR SHALL CONTROL BEARING FUNCTIONS FROM DRIVERS CAB.
 - CRANE OPERATOR SHALL CONTROL BEARING FUNCTIONS FROM THE OPERATOR'S CAB.
 - DELEGATED SIGNALMAN DIRECTS CRANE AND CARRIER MOVEMENTS FROM THE GROUND. PROVIDE CONTINUOUS VISIBILITY FOR ALL OPERATIONS.
 - CRANE OPERATOR SHALL BE SEATED IN THE OPERATOR'S CAB.
- AFTER LIFTING THE LOAD, THE BOOM SHALL REMAIN CENTERED WITHIN 5' CIRCLES OF CRANE AXIS AT ALL TIMES DURING TRAVEL. ON ROLLING OUTRIGGERS, SIGHTED RADII SHOULD BE HOLDING AREA IN ACCORDANCE WITH THE "IN-TRANSIT" CHART COLUMN ON THIS SHEET.
- POSITION FRONT OUTRIGGERS AND FRONT STABILIZER AS CLOSE TO THE FOUNDATION AS PRACTICAL.
 - POSITION REAR OUTRIGGERS AS CLOSE TO THE FOUNDATION AS PRACTICAL.
 - PREVENT LOAD FROM SWINGING VIA HAND-FIELD TECHNIQUE. HALT TRAVEL IF SWINGING PERSISTS.

- CRANE CHARTS (FOR CRANE CONFIGURED WITH 68,500 POUND COUNTERWEIGHT)**
- URING TRANSIT PORTIONS OF LIFTING AND SETTING OPERATION, COUNTER LOAD AT RADII USING THE CHART VALUES SHALL BE MAINTAINED. THIS SHALL PROVIDE COUNTERLOAD TO SHORTEN RADII WHILE TRAVELING WITH THE SUSPENDED LOAD.
 - IN A STATIC CONDITION, IF SWINGING THE LOAD BEHIND THE REAR OUTRIGGER IS REQUIRED, REFER TO OVER SIZE & FRONT AS APPROPRIATE. ALSO OPERATE THE FRONT OUTRIGGERS PER RADII OF THE CHART.
 - IF IT BECOMES NECESSARY TO OPERATE ON RUBBER WITH ROLLING OUTRIGGERS, OPERATORS GET THE COUNTERWEIGHT TO APPROX 50,000 POUNDS FREE CAPACITY CHART WITH 68,500 POUNDS COUNTERWEIGHT.

REFERENCES:
 ASME B30.5 "MOBILE AND LOCOMOTIVE CRANES"

PROJECT:
NESS 8470 TRUCK CRANES
 SN: 8206H-02939 & 8009A-02933

TRUCK CRANE W/ ROLLING OUTRIGGERS
 PROCEDURES AND CONTROLS

REVISED BY: [Signature]
 DATE: [Blank]
 CHECKED BY: [Blank]
 DATE: [Blank]

1 OF 3

NESS CAMPBELL
 CRANE + RIGGING

PORTLAND OFFICE: 503.289.3111
 SEATTLE OFFICE: 206.784.1054
 WWW.NESSCAMPBELL.COM