

# LS Conversion Components

<b>Adapter Pipes</b> . . . . .	261
<b>Engine Conversion Kit for Straight Axle</b> . . . . .	261
<b>Engine Install Kits</b> . . . . .	257
<b>Engine Mounts</b> . . . . .	258
<b>Engine Accessory Drive Kits</b> . . . . .	257
<b>Exhaust Manifolds</b> . . . . .	261
<b>Fuel Filter Regulator Kit</b> . . . . .	262
<b>Fuel Line Kit</b> . . . . .	262
<b>Fuel Pump</b> . . . . .	262
<b>Fuel Pump Kit</b> . . . . .	262
<b>Header Kits</b> . . . . .	258
<b>Oil Pan Kits</b> . . . . .	259, 260
<b>Oxygen Sensor</b> . . . . .	262
<b>Oxygen Sensor Bung</b> . . . . .	262
<b>Transmission Crossmember</b> . . . . .	261
<b>Tune Up Kits</b> . . . . .	258
<b>Tuning Software</b> . . . . .	258
<b>Wire Harnesses</b> . . . . .	263





#CPLS1-SAK

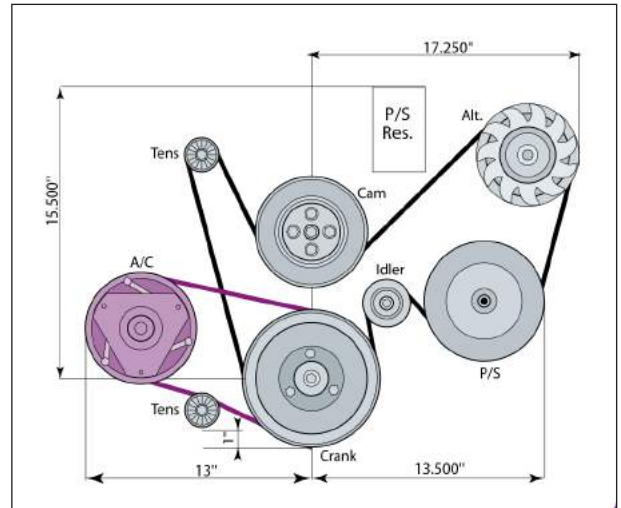

#CPLS1-SAK-TN

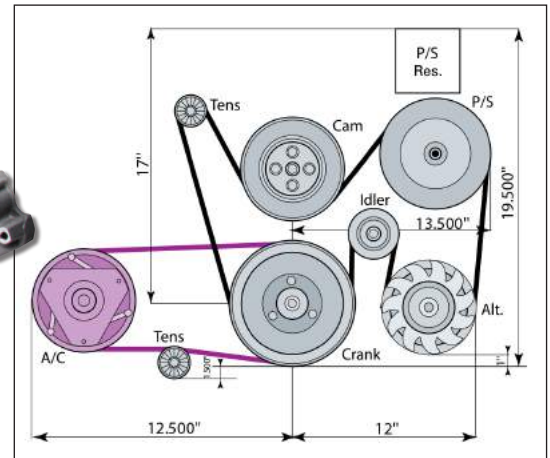

**ENGINE INSTALL KITS FOR LS1, LS2, LS3, & LS6**

It's time to install an engine that requires no maintenance, is super light-weight, puts out unbelievable horsepower and torque yet gives you a car you can just jump in, hit the key and go. We've got just what you need to finish off that motor and get it into your ride. These kit will work on all LS motors and 2000 and newer Vortec motors. Kit includes A/C compressor and bracket, P/S pump and bracket, P/S reservoir, alternator and bracket, pulleys, tensioners, belts and hardware.

<b>CPLS1-SAK</b>	Engine accessory kit	<b>\$1,529.00</b>
<b>CPLS1-SAK-TN</b>	Engine accessory kit	<b>\$1,529.00</b>
<b>25960709</b>	Power Steering Pump, each	<b>\$300.00</b>
<b>26046502</b>	Plastic Reservoir, each	<b>\$57.00</b>
<b>12568997</b>	Power Steering Pulley, each	<b>\$26.00</b>
<b>12555222</b>	Reservoir Bracket, each	<b>\$10.00</b>

**Holley**

**NEW!**

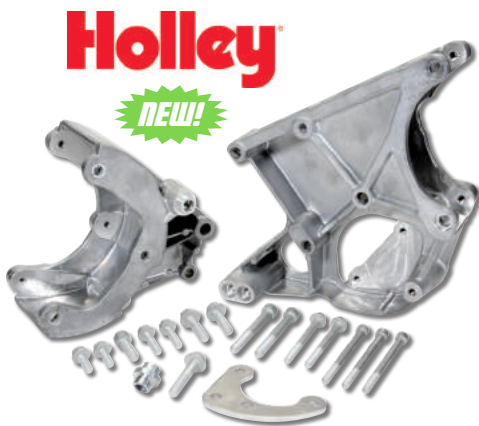

#20-131



#21-1



#21-2



#21-3

**LS ENGINE ACCESSORY DRIVE KITS**

Holley is proud to announce a simple, clean, cost effective accessory drive solution that solves the challenges encountered when swapping an LS motor into a muscle car, truck, hot rod or other vehicle. These brackets look truly at home on any LS engine as if they came from the factory this way. Accessory drive bracket kits come as driver side only (alternator/power steering mount), passenger side only (R4 air conditioning mount) or as a complete kit with both. You will also need an installation kit depending on whether you are using standard belt alignment (Corvette, CTS-V & G8) middle belt alignment (F-body & GTO) or long belt alignment (trucks & '00-up Camaro).

<b>20-131</b>	LS Accessory Drive Bracket (for R4 compressor) kit	<b>\$249.00</b>
<b>20-132</b>	LS Accessory Drive Bracket (for Sanden compressor) kit	<b>\$269.00</b>
<b>20-135</b>	LS Accessory Bracket kit (no compressor brackets)	<b>\$149.00</b>
<b>21-1</b>	LS Installation Kit (standard belt alignment)	<b>\$53.00</b>
<b>21-2</b>	LS Installation Kit (middle belt alignment)	<b>\$69.00</b>
<b>21-3</b>	LS Installation Kit (long belt alignment)	<b>\$100.00</b>





## LS1 ENGINE MOUNTS

CPP has all the combinations of LS engine brackets to get your motor into your project.

<b>12621HKR</b>	LS swap engine plates, clamshell style, kit	<b>\$115.00</b>
<b>12624HKR</b>	LS swap engine plates (1/2" forward), kit	<b>\$86.00</b>
<b>LS1-KS</b>	LS swap engine plates (stock location), kit	<b>\$69.00</b>
<b>LS1-K3</b>	LS swap engine plates (3" forward), kit	<b>\$69.00</b>
<b>LS1-K125</b>	LS swap engine plates (1.25" forward), kit	<b>\$69.00</b>
<b>LS1-KU-P</b>	FitRite™ LS swap engine plates (adjustable 1/2" rear - 3-1/2" forward) with POLYPLUS™ pad mounts, kit	<b>\$129.00</b>
<b>LS1-KULAC-P</b>	FitRite™ LS swap engine plates (adjustable 2-1/4" - 3-3/4" forward for low A/C compressor) with POLYPLUS™ pad mounts, kit	<b>\$129.00</b>



## HEADER KITS

We've got hot rod headers for many applications in multiple finishes! Available for small block and big block Chevy, LS engines and the popular 348/409 motors. Small block applications have 1-5/8" tubes and big block applications have 1-3/4" tubes. Gaskets and collectors are also included. Mini starter may be required. *Note: LS headers will not work for LS7.*

<b>2313HKR</b>	Block hugger, LS, coated, pair	<b>\$428.00</b>
<b>H8027</b>	Block hugger, small block, raw, pair	<b>\$169.00</b>
<b>H8029</b>	Block hugger, big block, raw, pair	<b>\$189.00</b>
<b>H8014</b>	Block hugger, LS, raw, pair	<b>\$199.00</b>
<b>CPH-LS01</b>	Block hugger, LS, pair	<b>\$95.00</b>
<b>CPH-LS02</b>	LS, stainless steel, pair	<b>\$139.00</b>
<b>CPH-LS03</b>	Hugger headers, pair	<b>\$211.00</b>
<b>CPH-LS04</b>	Shorty, LS, stainless, pair	<b>\$239.00</b>

## TUNE UP KITS

Includes MSD 8.5mm ignition wires, NGK spark plugs, oxygen sensors and oxygen sensor bungs. LS1 and Vortec tune up kits have the option of choosing which style oxygen sensor is required (square black, square gray or flat black). This kit is complete and will work as a great upgrade on any conversion engine.



<b>PKIT-1008A</b>	1997-04 LS1 Engines (Corvette, Camaro, Firebird, GTO), flat black	<b>\$190.00</b>
<b>PKIT-1008B</b>	1997-04 LS1 Engines (Corvette, Camaro, Firebird, GTO), square black	<b>\$190.00</b>
<b>PKIT-1008C</b>	97-04 LS1 Engines (Corvette, Camaro, Firebird, GTO), square grey	<b>\$190.00</b>
<b>PKIT-1018</b>	2008 - up LS3 and Vortec engines (Corvette, Camaro, GMC Trucks, Chevy Trucks)	<b>\$230.00</b>
<b>PKIT-1011A</b>	1999 - 07 Vortec engines (GMC Trucks, Chevy Trucks), flat black	<b>\$200.00</b>
<b>PKIT-1011B</b>	1999 - 07 Vortec engines (GMC Trucks, Chevy Trucks), square black	<b>\$200.00</b>
<b>PKIT-1011C</b>	1999 - 07 Vortec engines (GMC Trucks, Chevy Trucks), square grey	<b>\$200.00</b>



## HP TUNERS PRO MPVI TUNING SOFTWARE

This software is regarded as the best for unlocking the power potential of any LS or Vortec Gen III or IV engine/transmission combination. It allows complete control of your LS or Vortec computer from removing VATs and lowering fan temperatures to tuning fuel and timing maps. This kit includes the complete VCM Tuning Software, Scanning Software, Wide Band Oxygen Sensor hook up, Tuning Cable and 8 Credits.

<b>P6021</b>	kit	<b>\$649.00</b>
--------------	-----	-----------------

### OIL PAN KITS AND COMPONENTS

Looking for a specialty oil pan kit to install that LS motor into your ride or a small block Chevy into your classic Nova? LS kits include oil pan and pickup tube. #5557LS1-OPK also includes dipstick tube and dipstick and is a factory style pan. #302-1 and #401-111 have a low profile design which is ideal for applications with limited cross member clearance. Nova kits include oil pan, oil pump pickup and gaskets. Milodon kits also include rear oil pan baffle, windage tray and windage tray stud kit. #CP1009 kits also include dipstick, tube and engine perch conversion kit.

<b>5557LS1-OPK</b>	<i>OE LS oil pan, kit</i>	<b>\$299.00</b>
<b>302-1</b>	<i>Holley LS oil pan, plain, kit</i>	<b>\$399.00</b>
<b>302-1BK</b>	<i>Holley LS oil pan, black, kit</i>	<b>\$399.00</b>
<b>302-1P</b>	<i>Holley LS oil pan, polished, kit</i>	<b>\$479.00</b>
<b>302-2</b>	<i>Holley LS oil pan, plain, kit</i>	<b>\$399.00</b>
<b>302-2BK</b>	<i>Holley LS oil pan, black, kit</i>	<b>\$399.00</b>
<b>302-2P</b>	<i>Holley LS oil pan, polished, kit</i>	<b>\$479.00</b>
<b>401-111</b>	<i>Mast LS oil pan, kit</i> <small>NEW</small>	<b>\$449.00</b>
<b>30710</b>	<i>Big block Chevy, each</i>	<b>\$129.00</b>
<b>30915</b>	<i>LS (will not fit 55-57 Chevy), each</i>	<b>\$369.00</b>
<b>18600</b>	<i>Oil pump pickup, small block, each</i>	<b>\$15.00</b>
<b>18610</b>	<i>Oil pump pickup, big block, each</i>	<b>\$18.00</b>

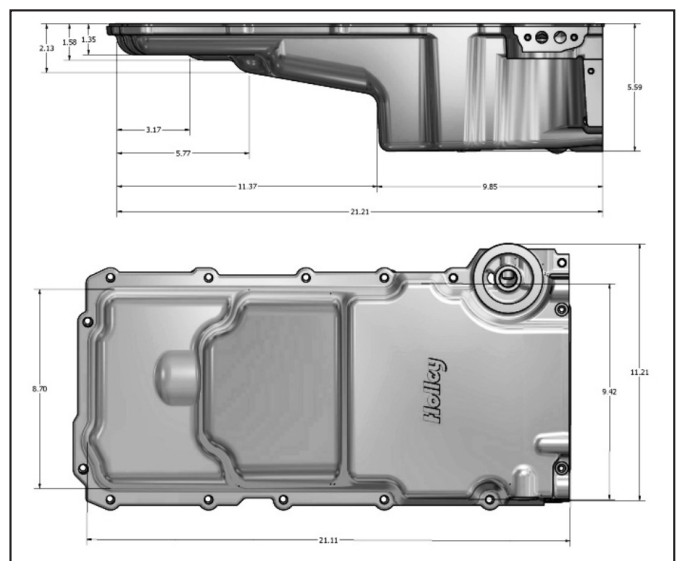
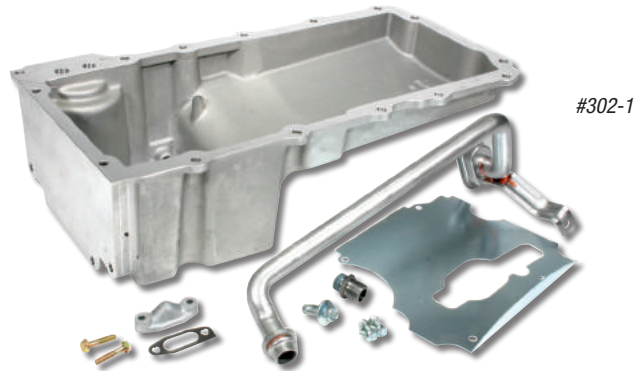
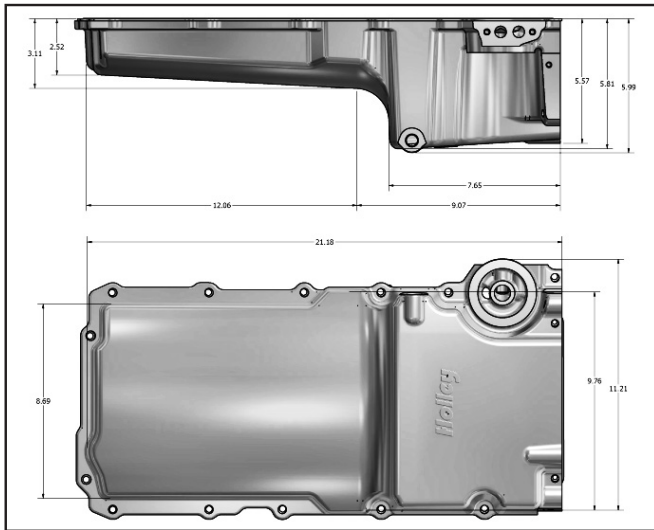
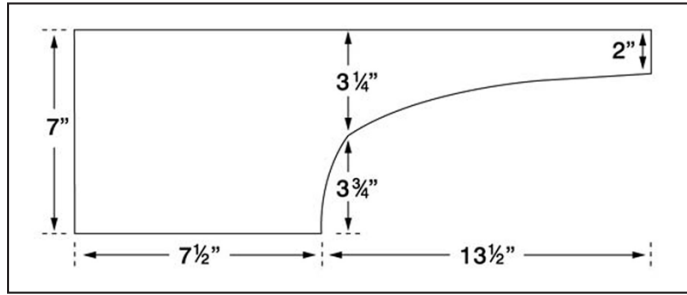
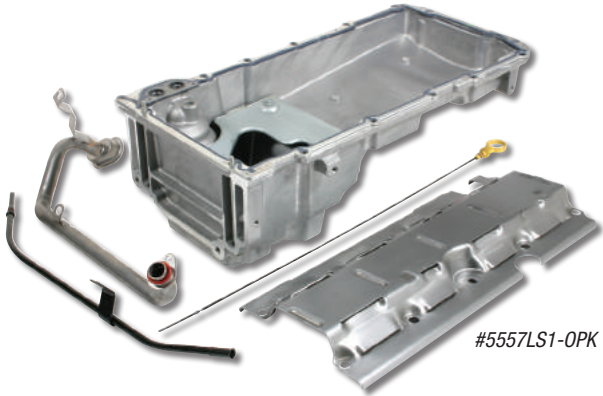

LS CONVERSION COMPONENTS



**NEW!**

### LS OIL PANS

These fabricated aluminum oil pans are a high performance addition to you LS motor and provide the most clearance available in an attractive aluminum finish. A wet sump, fully baffled design with seven quart capacity and will accommodate a 4.125" stroke with factory rods. No dipstick provision is provided and pickup, windage tray and gaskets are sold separately. Available in front or rear sump. Fits LS1 & LS6.

LS1-OPFS	Front sump, each	\$220.00
LS1-OPRS	Rear sump, each	\$220.00



**NEW!**

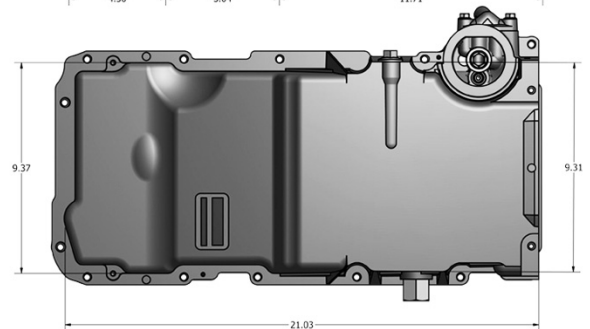
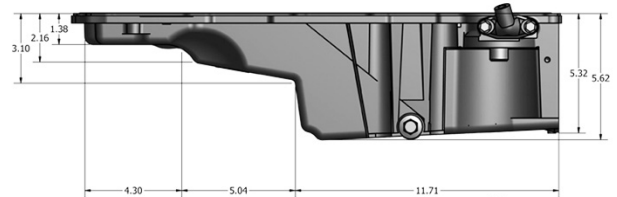
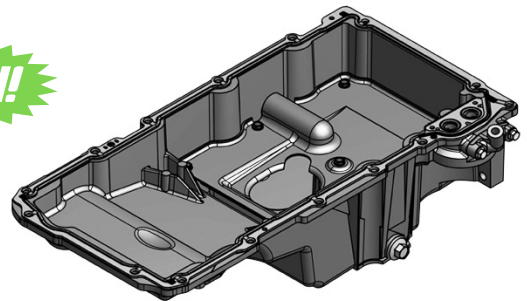

### F BODY OIL PAN KIT

This kit allows you to replace your stock LS or Vortec oil pan for proper clearance in your conversion vehicle. The F-Body pan will work in numerous applications. Includes NEW GM Oil Pan, Oil Pump Pickup Tube, Windage Tray, Dipstick Tube, Dipstick, seals and hardware for easy installation.

PKIT-1014	kit	\$375.00
-----------	-----	----------

Are you stuck?

Grab our Brake & Power Steering Installation Guide...

Call for a copy today or access it on our website 24 hours a day

@ [www.ClassicPerform.com](http://www.ClassicPerform.com)

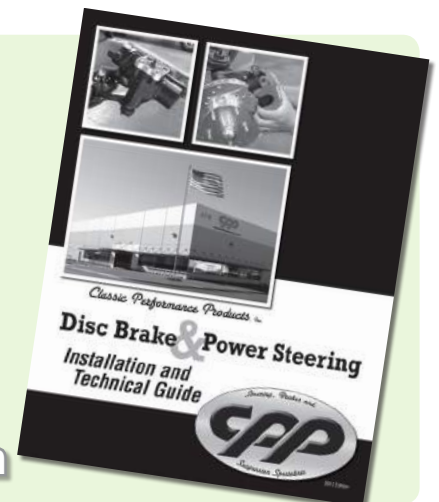





#8501-3HKR



#8501HKR

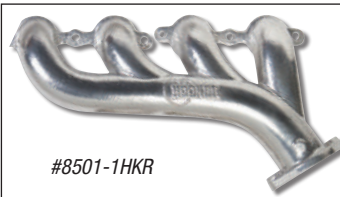

#8501-1HKR

### HOOKER EXHAUST MANIFOLDS

Hooker Headers are engineered to provide maximum exhaust flow increasing horsepower, torque and improving throttle response. Other features include tight tuck design for maximum clearance, Hi-Silicon-Moly ductile iron construction for increased durability and corrosion resistance, high flow design for maximum flow and reduced backpressure, and available in raw, high heat paint or ceramic coating options.

<b>8501HKR</b>	GM LS (except LS7 & LS9), raw finish	<b>\$427.00</b>
<b>8501-3HKR</b>	GM LS (except LS7 & LS9), black ceramic finish	<b>\$427.00</b>
<b>8501-1HKR</b>	GM LS (except LS7 & LS9), silver ceramic finish	<b>\$427.00</b>



#CP4810-LS1RK



#CP4810-LS1PK

### LS ENGINE CONVERSION KIT FOR STRAIGHT AXLE

Updating your early hauler to a modern drive train could not be any easier than our straight axle LS Series engine and LS adapter brackets. The crossmember can be bolted to the frame and the FitRite™ LS adapters will make installation quick and easy.

<b>CP4810-LS1PK</b>	Poly bushings, kit	<b>\$179.00</b>
<b>CP4810-LS1RK</b>	Rubber bushings, kit	<b>\$159.00</b>



### HOOKER ADAPTER PIPES

When connecting mid-length headers and cast iron manifolds to Hooker's full exhaust kits, an adapter pipe is required to fill that gap between the end of the headers or manifolds and Hooker's exhaust systems (which are designed to work with long tube header systems). Hooker has created a full line of adapter tubes that fill the gap and include all hardware and gaskets for a clean and simple connection. These adapter pipes are designed to connect #8501HKR exhaust manifolds to C10 LS Swap 2.5" exhaust systems. Stainless steel construction.

<b>70701403-RHKR</b>	1973-87 C10 LS Swap Mid-Pipe Adapter Pipes	<b>\$427.00</b>
----------------------	--	-----------------



### TRANSMISSION CROSSMEMBER

<b>CP90044</b>	1955-57 Chevy Fullsize, each	<b>\$89.00</b>
<b>XMCA67697</b>	Th700 Trans Crossmember, 1967-69 Camaro 700R4	<b>\$195.00</b>
<b>XMCA67698</b>	4L80E Trans Crossmember, 1967-69 Camaro 4L80E	<b>\$195.00</b>
<b>XMCA6769T</b>	T-56 Trans Crossmember, 1967-69 Camaro	<b>\$195.00</b>
<b>XMCA70747</b>	TH700 Trans Crossmember, 1970-74 Camaro 700R4	<b>\$195.00</b>
<b>XMCA75817</b>	700R4 Trans Crossmember, 1975-81 Camaro	<b>\$195.00</b>
<b>XMCH64677</b>	TH700 Trans Crossmember, 1964-67 Chevelle 700R4 hard top	<b>\$225.00</b>



For a more in-depth look at some of our featured products, go to:

<http://www.cpptalk.com/ShopTalkSite/>

LS CONVERSION COMPONENTS



**NEW!**

### FUEL PUMP KITS

This kit is complete to work without modification to your stock LS/Vortec or LT1/4 Fuel Rails. External pump kits include a high flow externally mounted 255-lph fuel pump. Includes braided steel fuel line, fuel fittings, Corvette fuel filter/pressure regulator and all fittings required for installation.

<b>PKIT-1017</b>	LS/Vortec External mount	<b>\$465.00</b>
<b>PKIT-1004</b>	LS/Vortec External mount, High Horsepower	<b>\$505.00</b>
<b>PKIT-1007</b>	LS/Vortec Internal mount	<b>\$429.00</b>
<b>PKIT-1003</b>	LT1/LT4 Internal mount (no Corvette fuel filter/pressure regulator)	<b>\$429.00</b>

### LS FUEL LINE KIT

Purchasing a LS style gas tank conversion? We now have a complete fuel line and regulator kit to plumb all your fuel lines in your ride. Comes with fuel hose, all fittings (standard or 45° ends), and regulator/filter combo.



**NEW!**

<b>LS-LINE-KIT</b>	Fuel line kit for LS engine	<b>\$235.00</b>
<b>LS-LINE-KIT45</b>	Fuel line kit for LS engine with 2- 45 degree hose ends	<b>\$247.00</b>

### LS FUEL FILTER REGULATOR KIT

These fuel regulator/filter combinations are a must with any LS engine conversion. Available in standard barb or -6AN Quick disconnect fittings. Perfect for plumbing your own fuel system.



**NEW!**

<b>LS9904</b>	LS fuel filter/regulator 58 psi, each	<b>\$35.00</b>
<b>LS9904-KIT</b>	LS fuel filter/regulator 58 psi, with -6 AN quick disconnect fittings, kit	<b>\$70.00</b>



**NEW!**

### FUEL PUMPS

These Walbro 255-lph fuel pump is ideal for all for all Gen III and Gen IV LS and VORTEC engine conversions. It delivers more than enough fuel to power your engine conversion. Its universal design is perfect for any conversion. These Walbro high-pressure inline fuel pumps have a lightweight, compact design that fits most EFI applications, including turbo and supercharged, and are QS9000 certified. They're ideal as universal fuel pumps for replacement, racing, or performance purposes where higher pressure fuel is necessary. So, when it comes to your fuel delivery needs, you can depend on Walbro! *Note that these pumps are great for a conversion that already uses an internal pump like GM C/K Trucks and Ford Mustangs. It includes wiring and pick up filter.*

<b>PACC-1026</b>	External mount	<b>\$130.00</b>
<b>PACC-1016</b>	Internal mount	<b>\$130.00</b>

### CORVETTE FUEL FILTER/PRESSURE REGULATOR

This filter/pressure regulator allows perfect fuel pressure for any LS or Vortec conversion. Simply plumb your fuel supply line, fuel return line and a single line to the engine and your fuel system is completed. No need for a secondary regulator or filter.



**NEW!**

<b>PACC-1028</b>	each	<b>\$55.00</b>
------------------	------	----------------



**NEW!**

### OXYGEN SENSOR

These Oxygen Sensors are used in many OEM applications including all LT1, LS and Vortec Engines with Drive by Cable and Drive by Wire Throttle Body.

<b>PACC-1036</b>	4 wire, square black	<b>\$60.00</b>
<b>PACC-1002</b>	For Vortec Engine, square white	<b>\$60.00</b>
<b>PACC-1003</b>	For LS and Vortec Gen IV 58X Engine, triangular gray	<b>\$85.00</b>

### OXYGEN SENSOR BUNG

These weld-in oxygen sensor fittings are a must when you're retrofitting either fuel injection or testing equipment to the exhaust of your vehicle. For all LT1, LS and Vortec Engines. They can be placed anywhere in the exhaust system and come ready for installation.



<b>PACC-1024</b>	each	<b>\$8.00</b>
------------------	------	---------------

**Classic-Fit**  
**EFI**  
FUEL INJECTION-READY TANKS

## Check out our EFI Gas Tanks

Chevy Truck..... page 52  
 Chevy Fullsize..... page 133  
 Nova & Camaro..... page 178  
 Chevelle & El Camino..... page 216



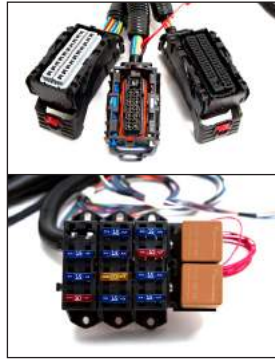
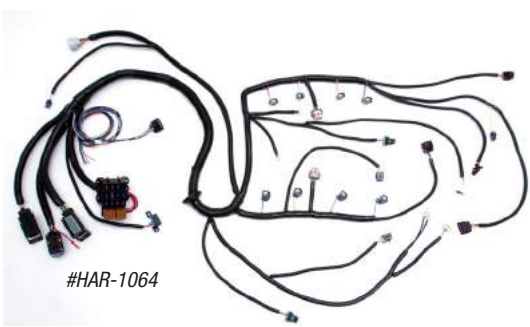

**WIRE HARNESSSES**

So you have our LS Series engine installed and now you are ready to wire it all up? These harnesses are designed for retrofitting LS Series engines in your older Classic Car or truck, perfect for use with our engine upgrade install kits. These are a complete standalone harness that are year and model specific and work with all factory engine components. Available for all 4L60-80E series automatics as well as the popular T56 manual transmissions; See all applications below for your specific year and engine model. Please note Alternator Pin style, Mass Airflow sensor, CAM type and MAP Sensor type options below. These are based off your engines stock setup; so please call us directly with any questions if you are unsure of your particular setup. Harnesses are professionally constructed from brand new GM Delphi connectors and TXL (Polyethylene Cross Linked) high temperature wire to GM specifications. All harnesses are 100% quality inspected prior to shipping. *Note: Harnesses are for non-emissions equipped vehicles and do not include air pump or EGR provisions.*

HAR #	DESCRIPTION	ALTERNATOR TYPE	INJECTOR TYPE	MAF TYPE	CAM TYPE	MAP SENSOR TYPE	PRICE
HAR-1012	1997-2002 LS1 (5.7L) w/ 4L60E Auto Transmission Wiring Harness (DBC)	4 Pin	EV1	3 Pin	N/A	DELPHI	\$519.00
HAR-1013	1997-02 LS1 (5.7L) w/ T56 Manual Transmission Wiring Harness (DBC)	4 Pin	EV1	3 Pin	N/A	DELPHI	\$519.00
HAR-1014	2003-07 VORTEC w/ 4L60E Auto Transmission Wiring Harness (DBW)	4 Pin	Multec	5 Pin	N/A	DELPHI	\$549.00
HAR-1018	1999-03 VORTEC w/ 4L60E Auto Transmission Wiring Harness (DBC)	4 Pin	Multec	5 Pin	N/A	DELPHI	\$519.00
HAR-1035	2006-13 LS7 (7.0L) w/ T56 Manual Transmission Wiring Harness	4 Pin	EV6	LS3 MAF	NON-VVT	DELPHI	\$569.00
HAR-1036	2006-13 LS7 (7.0L) w/ 4L60E Auto Transmission Wiring Harness	4 Pin	EV6	LS3 MAF	NON-VVT	DELPHI	\$645.00
HAR-1037	2008-13 LS3 (6.2L) w/T56/TR6060 Manual Transmission Wiring Harness	4 Pin	EV6	LS3 MAF	NON-VVT	BOSCH	\$569.00
HAR-1038	2008-13 LS3 (6.2L) w/ 4L60E Auto Transmission Wiring Harness	4 Pin	EV6	LS3 MAF	NON-VVT	BOSCH	\$645.00
HAR-1045	2008-09 L76 (6.0L) w/T56/TR6060 Manual Transmission Wiring Harness	2 Pin	EV6	07-08 Vortec	NON-VVT	BOSCH	\$569.00
HAR-1046	2008-09 L76 (6.0L) w/ 4L60E Auto Transmission Wiring Harness	2 Pin	EV6	07-08 Vortec	NON-VVT	BOSCH	\$645.00
HAR-1063	2005-07 LS2 (6.0L) 58X ) w/T56/TR6060 Manual Transmission Wiring Harness	4 Pin	EV6	LS3 MAF	NON-VVT	DELPHI	\$569.00
HAR-1064	2005-07 LS2 (6.0L) 58X w/ 4L60E Auto Transmission Wiring Harness	4 Pin	EV6	LS3 MAF	NON-VVT	DELPHI	\$645.00
HAR-1065	2008 LS2 (6.0L) 58X ) w/T56/TR6060 Manual Transmission Wiring Harness	2 Pin	EV6	LS3 MAF	NON-VVT	DELPHI	\$569.00
HAR-1066	2008 LS2 (6.0L) 58X w/ 4L60E Auto Transmission Wiring Harness	2 Pin	EV6	LS3 MAF	NON-VVT	DELPHI	\$645.00
HAR-1067	2010-13 L99 (6.2L) ) w/T56/TR6060 Manual Transmission Wiring Harness	2 Pin	EV6	LS3 MAF	VVT	BOSCH	\$569.00
HAR-1068	2010-13 L99 (6.2L) w/ 4L60E Auto Transmission Wiring Harness	2 Pin	EV6	LS3 MAF	VVT	BOSCH	\$645.00
HAR-1070	2006-13 LS7 (7.0L) w/ 6L80E Auto Transmission Wiring Harness	4 Pin	EV6	LS3 MAF	NON-VVT	DELPHI	\$695.00
HAR-1071	2008-13 LS3 (6.2L) w/ 6L80E Auto Transmission Wiring Harness	4 Pin	EV6	LS3 MAF	NON-VVT	BOSCH	\$695.00
HAR-1075	2008-09 L76 (6.0L) w/ 6L80E Auto Transmission Wiring Harness	2 Pin	EV6	LS3 MAF	VVT	BOSCH	\$695.00
HAR-1077	2005-07 LS2 (6.0L) 58X w/ 6L80E Auto Transmission Wiring Harness	4 Pin	EV6	LS3 MAF	NON-VVT	DELPHI	\$695.00
HAR-1078	2008 LS2 (6.0L) w/ 6L80E Auto Transmission Wiring Harness	2 Pin	EV6	LS3 MAF	NON-VVT	DELPHI	\$695.00
HAR-1079	2010-13 L99 (6.2L) w/ 6L80E Auto Transmission Wiring Harness	2 Pin	EV6	LS3 MAF	VVT	BOSCH	\$695.00

LS CONVERSION COMPONENTS



IN OUR AREA?

Visit our showroom...

For directions and hours, see the inside front of this catalog or visit us online @ [www.classicperform.com](http://www.classicperform.com)