

G21/GSR21 SERIES UNITS

G21 and GSR21 units are condensing furnaces utilizing the pulse combustion process. Initially, combustion takes place in an enclosed chamber. Then, as combustion products pass through the heat exchanger system into a coil, the latent heat of combustion is extracted and water is condensed from the exhaust gas.

The unit uses a redundant gas valve to assure safety shut-off as required by A.G.A. The units are manufactured for natural gas application. L.P. kits for A.G.A. / C.G.A. units are available for field changeover.

An electronic direct spark ignition control initiates combustion. The ignition control serves four functions: pre-purge, ignition, flame sensing and post-purge. Controls reset in the event of nuisance lockout. The control also verifies loss of combustion during a cycle, closing the gas valve. A differential pressure switch shuts down the unit immediately if there are obstructions in the exhaust outlet or air intake.

A purge blower clears the combustion chamber before and after each heating cycle to ensure proper air mixture for start-up.

All units feature direct drive multi-speed blower motors.

"V" series units feature an electronically controlled blower motor (ICM1 or ICM2) controlled by a VSP control (VSP1 or VSP2-1). The VSP controls blower CFM using either a

PWM (pulse width modulation) signal or fixed 24 VAC or VDC signal.

These signals are generated by optional controls such as the Harmony zone control system, Efficiency Plus Humidity Control (CCB1) or a thermostat. A PWM signal is generated by the Harmony zone control system. A fixed DC signal is generated by the Efficiency Plus Humidity Control (CCB1) and a 24 VAC signal is generated by a thermostat.

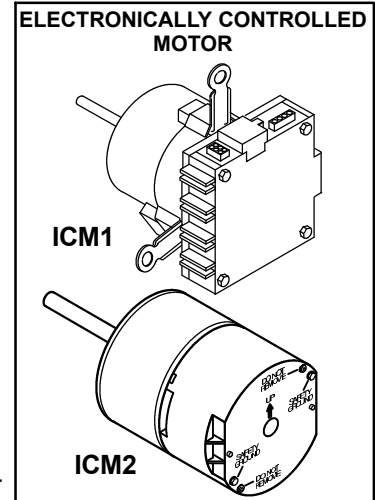

The Harmony zone control system produces a PWM signal to regulate blower CFM. The CCB1 varies indoor blower speed in response to indoor humidity demand. The CCB1 produces a DC signal.

When a two-speed condensing unit is used with the Harmony zone control system or CCB1, compressor speed as well as indoor blower CFM are controlled more accurately than with a conventional two stage thermostat.

All specifications in this manual are subject to change.

PULSE COMBUSTION PROCESS

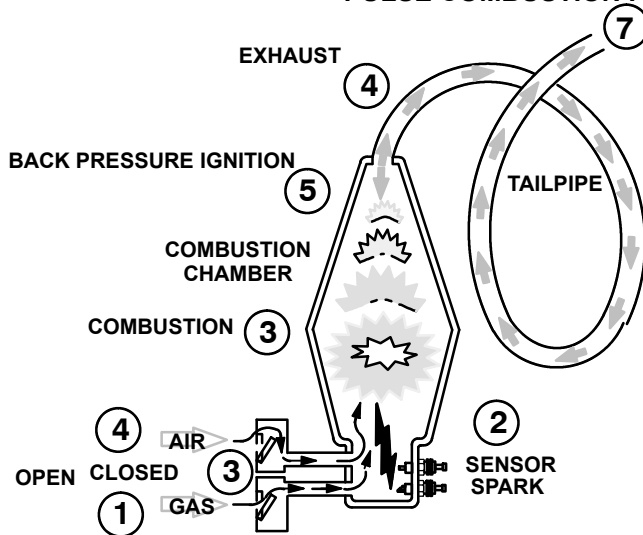

- 1 - Gas and air enter and mix in combustion chamber
- 2 - To start the cycle a spark is used to ignite the gas and air mixture (this is one "pulse").
- 3 - Positive pressure from combustion closes flapper valves and forces exhaust gases down the tailpipe.
- 4 - Exhaust gases leaving chamber create a negative pressure. This opens the flapper valve drawing in gas and air.
- 5 - At the same instant, part of the pulse is reflected back from the tailpipe causing the new gas and air mixture to ignite. No spark is needed. (this is another "pulse").
- 6 - Steps 4 and 5 repeat 60 to 70 times per second forming consecutive "pulses" of 1/4 to 1/2 Btuh each.
- 7 - Latent heat is removed from combustion products and condensate (water) is formed in the condensate coil.

TABLE OF CONTENTS

General ----- Page 1	Electrical Checkout ----- Page 59
Parts Arrangement ----- Page 3	Gas, Air, Spark Check ----- Page 60
Specifications ----- Page 4-6	Electrical Testing ----- Page 61
Blower Data ----- Page 6-10	ICM2-VSP2 ----- Page 62
Component Illustration ----- Page 11	ICM1-VSP1 ----- Page 63-65
I Application ----- Page 12	Additional Charts ----- Page 66-68
II Unit Components ----- Page 12-36	VIII Wiring and Sequence of Operation -----
VSP1 Blower Control ----- Page 15-16	G21Q ----- Page 69-70
VSP2 Blower Control ----- Page 17-19	GSR21Q ----- Page 71-72
Ignition Control ----- Page 21-24	G21V ----- Page 73-74
Blower Motor Q Units ----- Page 29	GSR21V ----- Page 75-76
ICM1 and ICM2 ----- Page 30-36	G21Q W/ GC3 ----- Page 77-78
III Installation ----- Page 36-44	G21Q W/ GC1 ----- Page 79-80
IV Maintenance ----- Page 45-46	GSR21Q W/ GC3 ----- Page 81-82
V Unit Checkout ----- Page 46-53	GSR21Q W/ GC1 ----- Page 83-84
VI Troubleshooting ----- Page 54-56	G21V W/ GC1 ----- Page 85-86
VII Troubleshooting Charts Page 57-68	G21V W/ GC3 ----- Page 87-88
GC1 Ignition Control ----- Page 57	GSR21V W/ GC1 ----- Page 89-90
GC3 Ignition Control ----- Page 58	GSR21V W/ GC3 ----- Page 91-92
G891 Ignition Control ----- Page 58	Jumper Summary Tables ----- Page 93-99

ELECTROSTATIC DISCHARGE (ESD) Precautions and Procedures

CAUTION

Electrostatic discharge can affect electronic components. Take precautions during furnace installation and service to protect the furnace's electronic controls. Precautions will help to avoid control exposure to electrostatic discharge by putting the furnace, the control and the technician at the same electrostatic potential. Neutralize electrostatic charge by touching hand and all tools on an unpainted unit surface, such as the gas valve or blower deck, before performing any service procedure.

PARTS ARRANGEMENT (G21 UPFLOW UNIT)

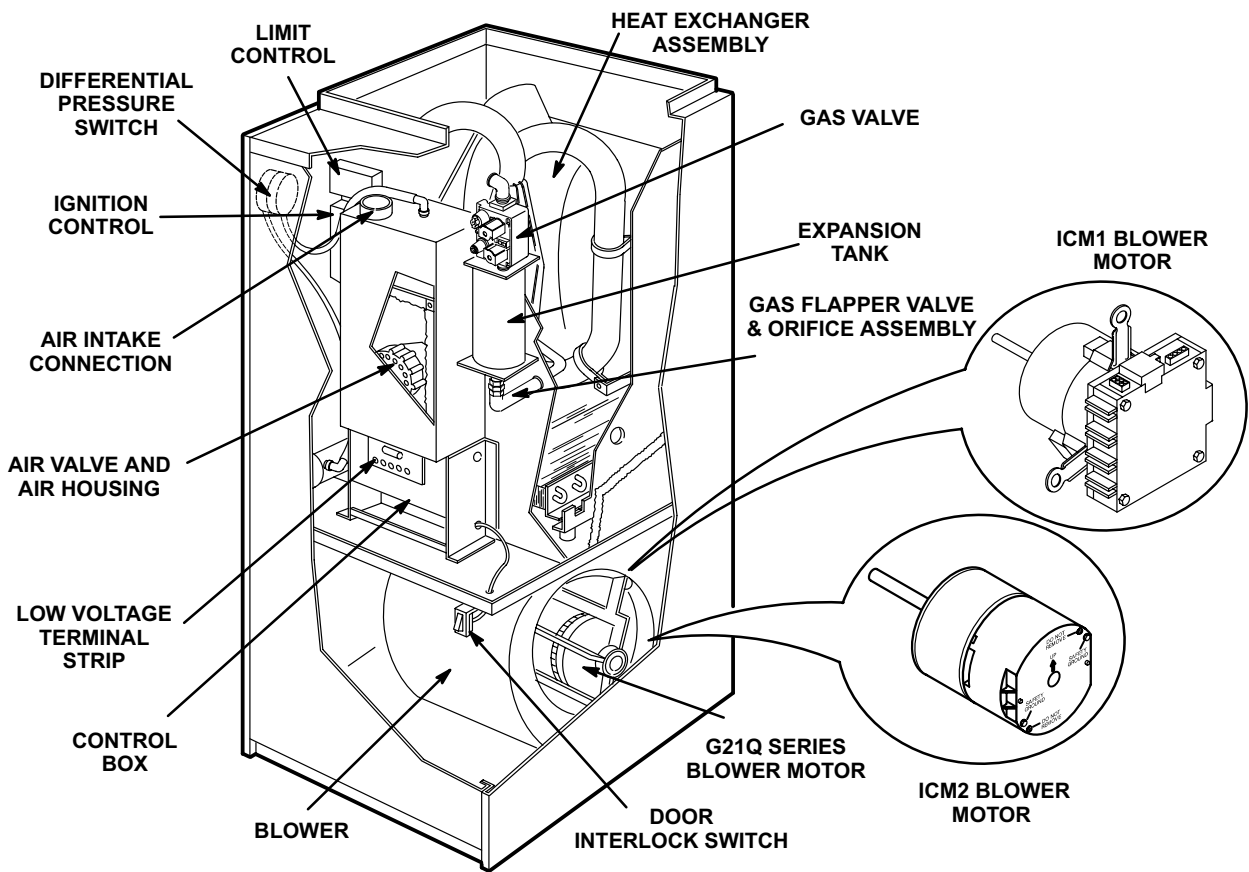

PARTS ARRANGEMENT (GSR21 DOWNFLOW HORIZONTAL UNIT)

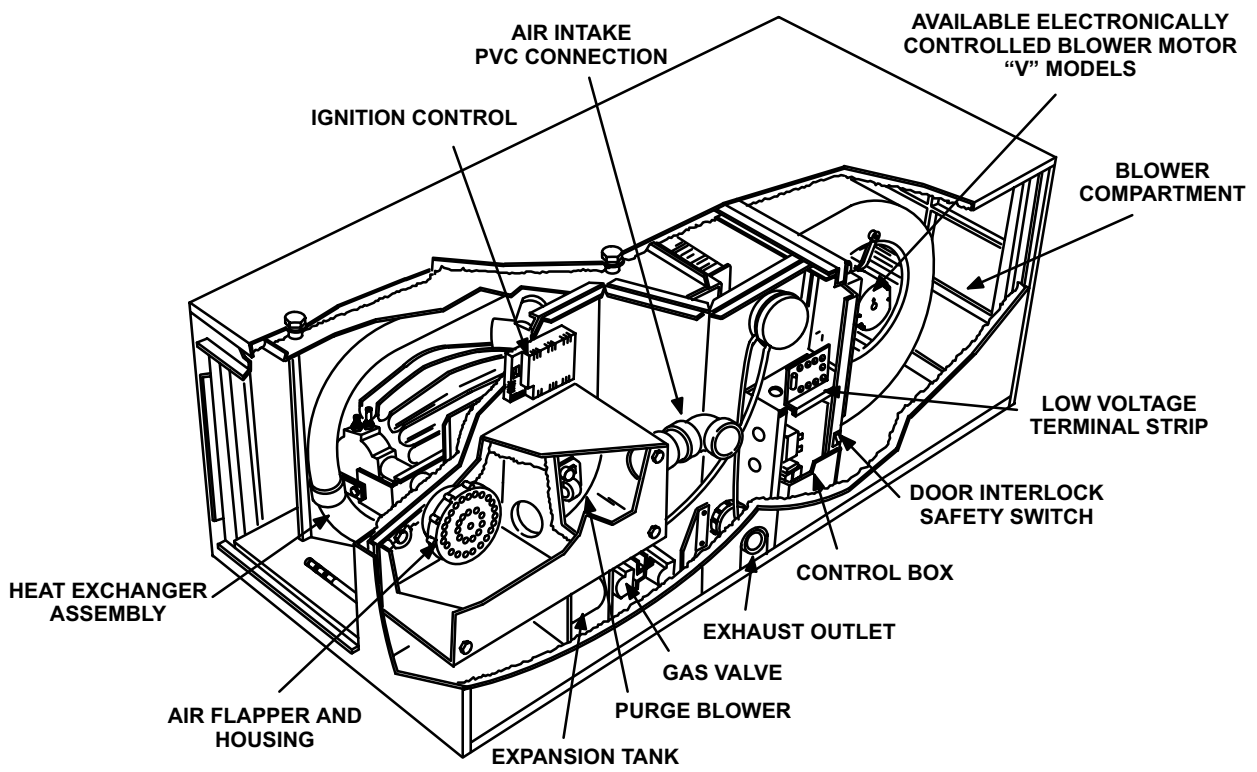

SPECIFICATIONS (units equipped with conventional multi-speed blower motor)

Model No.		G21Q3-40	G21Q3-60	G21Q4-60
Input Btuh		40,000	60,000	60,000
Output Btuh		38,000	55,000	55,000
*A.F.U.E.		96.2%	94.1%	94.1%
California Seasonal Efficiency		90.7%	89.9%	88.8%
Temperature rise range (°F)		35 — 65	40 — 70	35 — 65
High static certified by A.G.A. (in wg.)		.50	.50	.50
Gas Piping Size I.P.S. (in.)	Natural	1/2	1/2	1/2
	**LPG	1/2	1/2	1/2
Vent/Intake air pipe size connection (in.)		2	2	2
Condensate drain connection (in.) SDR11		1/2	1/2	1/2
Blower wheel nominal diameter x width (in.)		10 x 8	10 x 8	11 x 9
Blower motor hp		1/3	1/3	1/2
Number and size of filters (in.)		(1) 16 x 25 x 1	(1) 16 x 25 x 1	(1) 16 x 25 x 1
Tons of cooling that can be added		1-1/2 — 3	1-1/2 — 3	2-1/2 — 4
Electrical characteristics		120 volts — 60 hertz — 1 phase (less than 12 amps) All models		
**LPG kit (optional)		LB-65810A	LB-65810B	LB-65810B
External Filter Mounting Kit (optional)	Part No.	LB-81871CA	LB-81871CA	LB-81871CA
	•Filter size (in.)	(1) 16 x 25 x 1	(1) 16 x 25 x 1	(1) 16 x 25 x 1

•Filter is not furnished with kit. Filter kit utilizes existing filter supplied with G21 unit.

*Annual Fuel Utilization Efficiency based on D.O.E. test procedures and according to F.T.C. labeling regulations.

Isolated combustion system rating for non-weatherized furnaces.

**LPG kit must be ordered extra for field changeover.

SPECIFICATIONS (units equipped with conventional multi-speed blower motor)

Model No.		G21Q3-80	G21Q4-80	G21Q5-80	G21Q3-100	G21Q4/5-100
Input Btuh		80,000	80,000	80,000	100,000	100,000
Output Btuh		73,000	73,000	74,000	93,000	95,000
*A.F.U.E.		93.9%	93.9%	93.2%	94.9%	94.5%
California Seasonal Efficiency		90.1%	88.9%	88.3%	90.8%	89.6%
Temperature rise range (°F)		45 — 75	40 — 70	35 — 65	55 — 85	40 — 70
High static certified by A.G.A. (in wg.)		.50	.50	.50	.50	.50
Gas Piping Size I.P.S. (in.)	Natural	1/2	1/2	1/2	1/2	1/2
	**LPG	1/2	1/2	1/2	1/2	1/2
Vent/Intake air pipe size connection (in.)		2	2	2	2	2
Condensate drain connection (in.) SDR11		1/2	1/2	1/2	1/2	1/2
Blower wheel nominal diameter x width (in.)		10 x 8	11 x 9	12 x 12	10 x 8	12 x 12
Blower motor hp		1/3	1/2	3/4	1/2	3/4
Number and size of filters (in.)		(1) 16 x 25 x 1	(1) 16 x 25 x 1	(1) 20 x 25 x 1	(1) 20 x 25 x 1	(1) 20 x 25 x 1
Tons of cooling that can be added		2 — 3	2-1/2 — 4	4 or 5	2 — 3	3-1/2 — 5
Electrical characteristics		120 volts — 60 hertz — 1 phase (less than 12 amps) All models				
**LPG kit (optional)		LB-65810B	LB-65810B	LB-65810B	LB-65810C	LB-65810C
External Filter Mounting Kit (optional)	Part No.	LB-81871CA	LB-81871CA	LB-81871CB	LB-81871CB	LB-81871CB
	•Filter size (in.)	(1) 16 x 25 x 1	(1) 16 x 25 x 1	(1) 20 x 25 x 1	(1) 20 x 25 x 1	(1) 20 x 25 x 1

•Filter is not furnished with kit. Filter kit utilizes existing filter supplied with G21 unit.

*Annual Fuel Utilization Efficiency based on D.O.E. test procedures and according to F.T.C. labeling regulations.

Isolated combustion system rating for non-weatherized furnaces.

**LPG kit must be ordered extra for field changeover.

SPECIFICATIONS (contd.)

SPECIFICATIONS (units equipped with conventional multi-speed blower motor)

Model No.		GSR21Q3-50	GSR21Q4-50	GSR21Q3-80	GSR21Q4/5-80	GSR21Q4/5-100
Input Btuh		50,000	50,000	80,000	80,000	100,000
Output Btuh		47,000	47,000	71,000	72,000	92,000
*A.F.U.E.		94.8%	95.3%	91.7%	94.1%	92.0%
California Seasonal Efficiency		89.7%	90.1%	87.6%	88.6%	87.3%
Temperature rise range (°F)		30 — 60	25 — 55	40 — 70	30 — 60	45 — 75
High static certified by A.G.A. (in wg.)		.50	.50	.50	.50	.50
Gas Piping Size I.P.S. (in.)	Natural	1/2	1/2	1/2	1/2	1/2
	•LPG	1/2	1/2	1/2	1/2	1/2
Vent/Intake air pipe size connection (in.)		2	2	2	2	2
Condensate drain connection (in.) SDR11		1/2	1/2	1/2	1/2	1/2
Blower wheel nominal diameter x width (in.)		10 x 8	10 x 10	10 x 10	12 x 12	12 x 12
Blower motor hp		1/3	1/2	1/3	3/4	3/4
Number and size of filters (in.)		(1) 20 x 25 x 1				
Tons of cooling that can be added		1-1/2 — 3	3-1/2 — 4	2 — 3	3-1/2 — 5	3-1/2 — 5
Electrical characteristics		120 volts — 60 hertz — 1 phase (less than 12 amps) All models				
LPG kit (optional)		**Furnished				•LB-65810C
Optional Horizontal Support Frame Kit — Ship. Weight		LB-56495CA (All Models) — 18 lbs.				
Optional Downflow Additive Base — Shipping Weight		LB-80639BB (All Models) — 6 lbs.				

•LPG kit must be ordered extra for field changeover.

*Annual Fuel Utilization Efficiency based on D.O.E. test procedures and according to F.T.C. labeling regulations.

Isolated combustion system rating for non-weatherized furnaces.

**LPG orifice furnished as standard with unit for field changeover. Convertible gas valve requires simple adjustment without adding any parts. See installation instructions.

SPECIFICATIONS (units equipped with electronically controlled blower motor)

Model No.		G21V3-60	G21V3-80	G21V5-80	G21V5-100
Input Btuh		60,000	80,000	80,000	100,000
Output Btuh		55,000	73,000	74,000	95,000
*A.F.U.E.		94.3%	94.5%	93.4%	94.5%
California Seasonal Efficiency		92.5%	92.4%	90.9%	91.5%
Temperature rise range (°F)		40 — 70	45 — 75	35 — 65	40 — 70
High static certified by A.G.A. (in wg.)		.80	.80	.80	.80
Gas Piping Size I.P.S. (in.)	Natural	1/2	1/2	1/2	1/2
	**LPG	1/2	1/2	1/2	1/2
Vent/Intake air pipe size connection (in.)		2	2	2	2
Condensate drain connection (in.) SDR11		1/2	1/2	1/2	1/2
Blower wheel nominal diameter x width (in.)		10 x 8	10 x 8	11-1/2 x 9	11-1/2 x 9
Blower motor hp		1/2	1/2	1	1
Number and size of filters (in.)		(1) 16 x 25 x 1	(1) 16 x 25 x 1	(1) 20 x 25 x 1	(1) 20 x 25 x 1
Tons of cooling that can be added		1-1/2, 2, 2-1/2 or 3	2, 2-1/2 or 3	3-1/2, 4 or 5	3-1/2, 4 or 5
Electrical characteristics		120V - 60hertz - 1 phase - 12.0 Amps Max		120V - 60hertz - 1 phase - 14.5 Amps Max	
External Filter Cabinet (furnished) •Filter size (in.)		(1) 16 x 25 x 1	(1) 16 x 25 x 1	(1) 20 x 25 x 1	(1) 20 x 25 x 1
**LPG kit (optional)		LB-65810B	LB-65810B	LB-65810B	LB-65810C

•Filter is not furnished with cabinet. Filter cabinet utilizes existing filter supplied with G21V unit.

*Annual Fuel Utilization Efficiency based on D.O.E. test procedures and according to F.T.C. labeling regulations.

Isolated combustion system rating for non-weatherized furnaces.

**LPG kit must be ordered extra for field changeover.

SPECIFICATIONS (contd.)

SPECIFICATIONS (units equipped with electronically controlled blower motor)

Model No.		GSR21V3-80	GSR21V5-80	GSR21V5-100
Input Btuh		80,000	80,000	100,000
Output Btuh		71,000	72,000	92,000
*A.F.U.E.		94.5%	94.6%	92.0%
California Seasonal Efficiency		92.5%	92.1%	89.7%
Temperature rise range (°F)		40 — 70	30 — 60	45 — 75
High static certified by A.G.A. (in wg.)		.80	.80	.80
Gas Piping Size I.P.S. (in.)	Natural	1/2	1/2	1/2
	•LPG	1/2	1/2	1/2
Vent/Intake air pipe size connection (in.)		2	2	2
Condensate drain connection (in.) SDR11		1/2	1/2	1/2
Blower wheel nominal diameter x width (in.)		10 x 8	11-1/2 x 9	11-1/2 x 9
Blower motor hp		1/2	1	1
Number and size of filters (in.)		(1) 20 x 25 x 1		
Tons of cooling that can be added		2 — 3	3-1/2 — 5	3-1/2 — 5
Electrical characteristics		120V - 60hertz - 1 phase 12.0 Amps Max	120V - 60hertz - 1 phase - 14.5 Amps Max	
•LPG kit (optional)		**Furnished		LB-65810C
Optional Horizontal Support Frame Kit — Ship. Weight		LB-56495CA (All Models) — 18 lbs.		
Optional Downflow Additive Base — Shipping Weight		LB-80639BB (All Models) — 6 lbs.		

•LPG kit must be ordered extra for field changeover.

*Annual Fuel Utilization Efficiency based on D.O.E. test procedures and according to F.T.C. labeling regulations.

Isolated combustion system rating for non-weatherized furnaces.

**LPG orifice furnished as standard with unit for field changeover. Convertible gas valve requires simple adjustment without adding any parts. See installation instructions.

BLOWER DATA

(units equipped with conventional multi-speed blower motor)

**G21Q3-40, G21Q3-60 AND G21Q3-80
BLOWER PERFORMANCE**

External Static Pressure (in. wg)	Air Volume @ Various Speeds		
	High	Medium	Low
0	1585	1392	920
.05	1558	1364	917
.10	1533	1354	915
.15	1505	1335	912
.20	1477	1315	905
.25	1447	1294	893
.30	1418	1272	887
.40	1355	1225	858
.50	1282	1164	803

NOTE — All cfm data is measured external to unit with the air filter in place.

G21Q5-80 BLOWER PERFORMANCE

External Static Pressure (in. wg)	Air Volume (cfm) @ Various Speeds				
	High	Med-High	Medium	Med-Low	Low
0	2460	2350	2155	1900	1695
.05	2430	2310	2130	1875	1675
.10	2395	2275	2100	1855	1655
.15	2355	2240	2065	1825	1625
.20	2315	2205	2035	1800	1600
.25	2275	2175	1995	1780	1570
.30	2235	2130	1960	1740	1540
.40	2155	2055	1880	1675	1480
.50	2070	1970	1790	1605	1410
.60	1980	1890	1710	1540	1345

NOTE — All cfm data is measured external to unit with the air filter in place.

BLOWER DATA (contd.) (units equipped with conventional multi-speed blower motor)

**G21Q4-60 AND G21Q4-80
BLOWER PERFORMANCE**

External Static Pressure (in. wg)	Air Volume @ Various Speeds		
	High	Medium	Low
0	1793	1295	1050
.05	1770	1290	1050
.10	1747	1285	1050
.15	1724	1280	1050
.20	1700	1275	1050
.25	1675	1267	1050
.30	1648	1258	1050
.40	1585	1233	1036
.50	1517	1193	1012

NOTE — All cfm data is measured external to unit with the air filter in place.

G21Q3-100 BLOWER PERFORMANCE

External Static Pressure (in. wg)	Air Volume @ Various Speeds		
	High	Medium	Low
0	1850	1660	1500
.05	1805	1635	1470
.10	1760	1610	1440
.15	1720	1575	1420
.20	1680	1540	1400
.25	1635	1505	1375
.30	1590	1470	1350
.40	1500	1400	1290
.50	1400	1320	1220
.60	1290	1230	1140

NOTE — All cfm data is measured external to unit with the air filter in place.

G21Q4/5-100 BLOWER PERFORMANCE

External Static Pressure (in. wg)	Air Volume (cfm) @ Various Speeds				
	High	Med-High	Medium	Med-Low	Low
0	2450	2340	2140	1910	1690
.05	2420	2310	2110	1880	1670
.10	2390	2270	2080	1860	1640
.15	2350	2240	2050	1830	1620
.20	2320	2210	2020	1800	1590
.25	2280	2170	1990	1770	1570
.30	2250	2140	1960	1740	1540
.40	2180	2060	1890	1680	1480
.50	2100	1980	1810	1610	1420
.60	2005	1890	1740	1530	1350

NOTE — All cfm data is measured external to unit with the air filter in place.

GSR21Q3-50 BLOWER PERFORMANCE

External Static Pressure (in. wg)	Air Volume (cfm) @ Various Speeds			
	High	Med-High	Med-Low	Low
0	1640	1405	1070	875
.05	1620	1390	1065	870
.10	1595	1375	1060	865
.15	1570	1360	1055	860
.20	1545	1345	1045	855
.25	1520	1325	1035	850
.30	1490	1305	1025	840
.40	1430	1260	995	810
.50	1365	1200	960	775
.60	1285	1135	910	735
.70	1195	1055	840	----
.80	1085	955	755	----

NOTE — All cfm data is measured external to unit with the air filter in place.

GSR21Q3-80 BLOWER PERFORMANCE

External Static Pressure (in. wg)	Air Volume @ Various Speeds		
	High	Medium	Low
0	1735	1455	1095
.05	1720	1445	1090
.10	1700	1435	1085
.15	1675	1420	1080
.20	1640	1405	1070
.25	1615	1385	1060
.30	1585	1355	1045
.40	1520	1290	995
.50	1440	1210	930
.60	1330	1120	870
.70	1180	1015	----
.80	1035	900	----

NOTE — All cfm data is measured external to unit with the air filter in place.

BLOWER DATA (contd.) (units equipped with conventional multi-speed blower motor)

GSR21Q4-50 BLOWER PERFORMANCE

External Static Pressure (in. wg)	Air Volume (cfm) @ Various Speeds			
	High	Med-High	Med-Low	Low
0	1935	1725	1530	1225
.05	1900	1695	1515	1220
.10	1865	1665	1490	1210
.15	1825	1630	1465	1195
.20	1790	1595	1435	1175
.25	1745	1560	1400	1140
.30	1700	1520	1365	1105
.40	1585	1420	1285	1030
.50	1470	1320	1200	975
.60	1360	1215	1115	920
.70	1235	1115	1030	----
.80	1105	1000	930	----

NOTE — All cfm data is measured external to unit with the air filter in place.

GSR21Q4/5-80 BLOWER PERFORMANCE

External Static Pressure (in. wg)	Air Volume (cfm) @ Various Speeds				
	High	Med-High	Medium	Med-Low	Low
0	2355	2205	1965	1740	1520
.05	2325	2175	1940	1715	1495
.10	2290	2150	1920	1695	1475
.15	2255	2115	1890	1670	1450
.20	2220	2085	1860	1645	1425
.25	2185	2050	1830	1620	1400
.30	2150	2020	1800	1595	1375
.40	2080	1950	1745	1540	1320
.50	2000	1880	1680	1475	1260
.60	1915	1805	1615	1410	1195
.70	1825	1720	1540	1330	----
.80	1730	1635	1460	1240	----

NOTE — All cfm data is measured external to unit with the air filter in place.

GSR21Q4/5-100 BLOWER PERFORMANCE

External Static Pressure (in. wg)	Air Volume (cfm) @ Various Speeds				
	High	Med-High	Medium	Med-Low	Low
0	2275	2140	1940	1725	1520
.05	2245	2110	1915	1700	1490
.10	2215	2075	1885	1675	1465
.15	2185	2040	1860	1645	1435
.20	2150	2005	1830	1620	1410
.25	2115	1970	1805	1590	1380
.30	2075	1935	1775	1560	1350
.40	1990	1870	1710	1500	1290
.50	1925	1800	1645	1435	1235
.60	1835	1730	1570	1370	1175
.70	1760	1650	1490	1300	----
.80	1675	1570	1400	1225	----

NOTE — All cfm data is measured external to unit with the air filter in place.

Units Equipped With an Electronically Controlled Blower Motor ICM2

**G21V3-60/80 BLOWER MOTOR PERFORMANCE
(For Static Pressure 0.0" to 0.8" w.g.)**

ADJUST JUMPER SETTING	LOW SPEED				HIGH (COOL) SPEED				HEAT SPEED			
	VSP2-1 JUMPER POSITION				VSP2-1 JUMPER POSITION				VSP2-1 JUMPER POSITION			
	1	2	3	4	1	2	3	4	1	2	3	4
+	540	700	830	1000	1150	1260	1400	1410	1150	1250	1350	1420
NORM	490	630	740	880	1040	1140	1240	1265	1030	1140	1220	1300
-	440	560	670	800	940	1030	1140	1160	920	1020	1100	1190

NOTE ADJUST position on JPB1 ("NORM", "+", or "-") determines the row of CFM available to use.

NOTE — All air data is measured external to the unit with the air filter in place.
Blower maintains a constant CFM throughout a range of varying static pressures.

BLOWER DATA (contd.) (units equipped with an electronically controlled blower motor ICM2)

**G21V5-80/100 BLOWER MOTOR PERFORMANCE
(For Static Pressure 0.0" to 0.8" w.g.)**

ADJUST JUMPER SETTING	LOW SPEED				HIGH (COOL) SPEED				HEAT SPEED			
	VSP2-1 JUMPER POSITION				VSP2-1 JUMPER POSITION				VSP2-1 JUMPER POSITION			
	1	2	3	4	1	2	3	4	1	2	3	4
+	800	1050	1410	1620	1710	2030	2270*	2270*	1900	2140	2270*	2270*
NORM	720	950	1280	1500	1570	1850	2100	2220	1700	1940	2080	2200
-	620	850	1120	1310	1420	1650	1860	1990	1520	1730	1860	1940

NOTE ADJUST position on JPBI ("NORM", "+", or "-") determines the row of CFM available to use.

*2300 CFM @ 0.2" w.g.; 2250 CFM @ 0.5" w.g.; 2200 CFM @ 0.8" w.g.

NOTE — All air data is measured external to the unit with the air filter in place.
Blower maintains a constant CFM throughout a range of varying static pressures.

**GSR21V3-80 BLOWER MOTOR PERFORMANCE
(For Static Pressure 0.0" to 0.8" w.g.)**

ADJUST JUMPER SETTING	LOW SPEED				HIGH (COOL) SPEED				HEAT SPEED			
	VSP2-1 JUMPER POSITION				VSP2-1 JUMPER POSITION				VSP2-1 JUMPER POSITION			
	1	2	3	4	1	2	3	4	1	2	3	4
+	520	670	800	960	1110	1220	1340	1420	1110	1210	1310	1420
NORM	480	600	740	880	1070	1160	1270	1300	1000	1100	1200	1280
-	420	550	650	770	950	1040	1150	1170	900	1000	1100	1160

NOTE ADJUST position on JPBI ("NORM", "+", or "-") determines the row of CFM available to use.

NOTE — All air data is measured external to the unit with the air filter in place.
Blower maintains a constant CFM throughout a range of varying static pressures.

**GSR21V5-80/100 BLOWER MOTOR PERFORMANCE
(For Static Pressure 0.0" to 0.8" w.g.)**

ADJUST JUMPER SETTING	LOW SPEED				HIGH (COOL) SPEED				HEAT SPEED			
	VSP2-1 JUMPER POSITION				VSP2-1 JUMPER POSITION				VSP2-1 JUMPER POSITION			
	1	2	3	4	1	2	3	4	1	2	3	4
+	860	1100	1460	1740	1800	2090	2100 *	2100 *	1930	2100 *	2100 *	2100 *
NORM	770	1020	1390	1580	1720	1990	2100 *	2100 *	1800	2000	2100 *	2100 *
-	680	900	1180	1400	1450	1690	1940	2040	1580	1780	1920	2010

NOTE ADJUST position on JPBI ("NORM", "+", or "-") determines the row of CFM available to use.

*2200 CFM @ 0.2" w.g.; 2100 CFM @ 0.5" w.g.; 2000 CFM @ 0.8" w.g.

NOTE — All air data is measured external to the unit with the air filter in place.
Blower maintains a constant CFM throughout a range of varying static pressures.

Units Equipped With an Electronically Controlled Blower Motor ICM1

G21V3-60, G21V3-80 BLOWER PERFORMANCE

FACTORY BLOWER SPEED SETTINGS

G21V3-60

Low Speed Heat/Cool — tap 2
 High Speed Cooling — tap 11
 High Speed Heat — tap 6

G21V3-80

Low Speed Heat/Cool — tap 2
 High Speed Cooling — tap 11
 High Speed Heat — tap 7

External Static Pressure (in. wg.)	Air Volume (cfm) @ Various Speeds										
	Tap 1	Tap 2	Tap 3	Tap 4	Tap 5	Tap 6	Tap 7	Tap 8	Tap 9	Tap 10	Tap 11
0 thru .80	----	490	635	760	880	1030	1140	1220	1345	1420	1420

NOTE — All air data is measured external to the unit with the air filter in place.
 *Blower maintains a constant CFM throughout a range of varying static pressures.

G21V5-80, G21V5-100 BLOWER PERFORMANCE

FACTORY BLOWER SPEED SETTINGS

G21V5-80

Low Speed Heat/Cool — tap 2
 High Speed Cooling — tap 11
 High Speed Heat — tap 6

G21V5-100

Low Speed Heat/Cool — tap 2
 High Speed Cooling — tap 11
 High Speed Heat — tap 7

External Static Pressure (in. wg.)	Air Volume (cfm) @ Various Speeds										
	Tap 1	Tap 2	Tap 3	Tap 4	Tap 5	Tap 6	Tap 7	Tap 8	Tap 9	Tap 10	Tap 11
0 thru .80	----	770	1015	1305	1510	1685	1820	2010	2050	2100	2100

NOTE — All air data is measured external to the unit with the air filter in place.
 *Blower maintains a constant CFM throughout a range of varying static pressures.

GSR21V3-80 BLOWER PERFORMANCE

FACTORY BLOWER SPEED SETTINGS

GSR21V3-80

Low Speed Heat/Cool — tap 3
 High Speed Cooling — tap 11
 High Speed Heat — tap 7

External Static Pressure (in. wg.)	Air Volume (cfm) @ Various Speeds										
	Tap 1	Tap 2	Tap 3	Tap 4	Tap 5	Tap 6	Tap 7	Tap 8	Tap 9	Tap 10	Tap 11
0 thru .80	----	----	480	655	790	960	1120	1220	1365	1460	1460

NOTE — All air data is measured external to the unit with the air filter in place.
 *Blower maintains a constant CFM throughout a range of varying static pressures.

GSR21V5-80, GSR21V5-100 BLOWER PERFORMANCE

FACTORY BLOWER SPEED SETTINGS

GSR21V5-80

Low Speed Heat/Cool — tap 2
 High Speed Cooling — tap 11
 High Speed Heat — tap 6

GSR21V5-100

Low Speed Heat/Cool — tap 2
 High Speed Cooling — tap 11
 High Speed Heat — tap 7

External Static Pressure (in. wg.)	Air Volume (cfm) @ Various Speeds										
	Tap 1	Tap 2	Tap 3	Tap 4	Tap 5	Tap 6	Tap 7	Tap 8	Tap 9	Tap 10	Tap 11
0 thru .80	----	890	990	1230	1425	1605	1735	1900	2015	2090	2090

NOTE — All air data is measured external to the unit with the air filter in place.
 *Blower maintains a constant CFM throughout a range of varying static pressures.

UNIT COMPONENTS UPFLOW "Q" UNITS

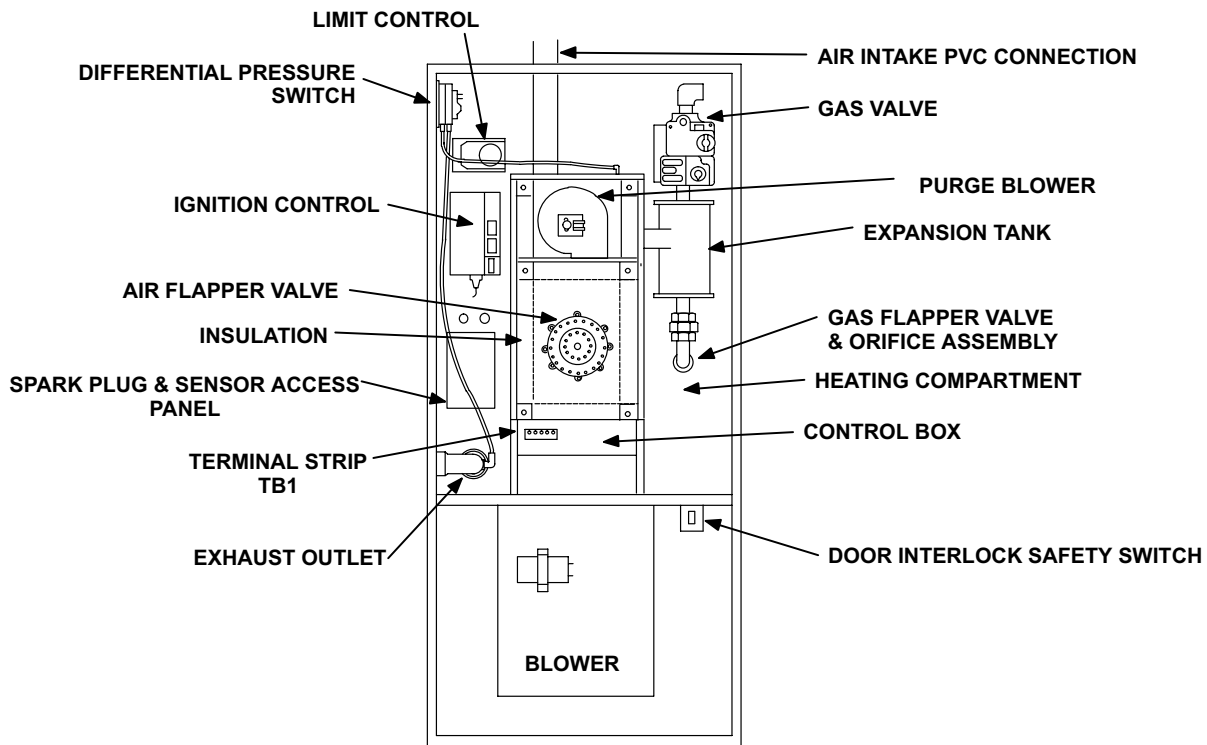

**UNIT COMPONENTS HORIZONTAL/REVERSE FLOW "V" UNITS
(ICM2 SHOWN WITH VSP2-1)**

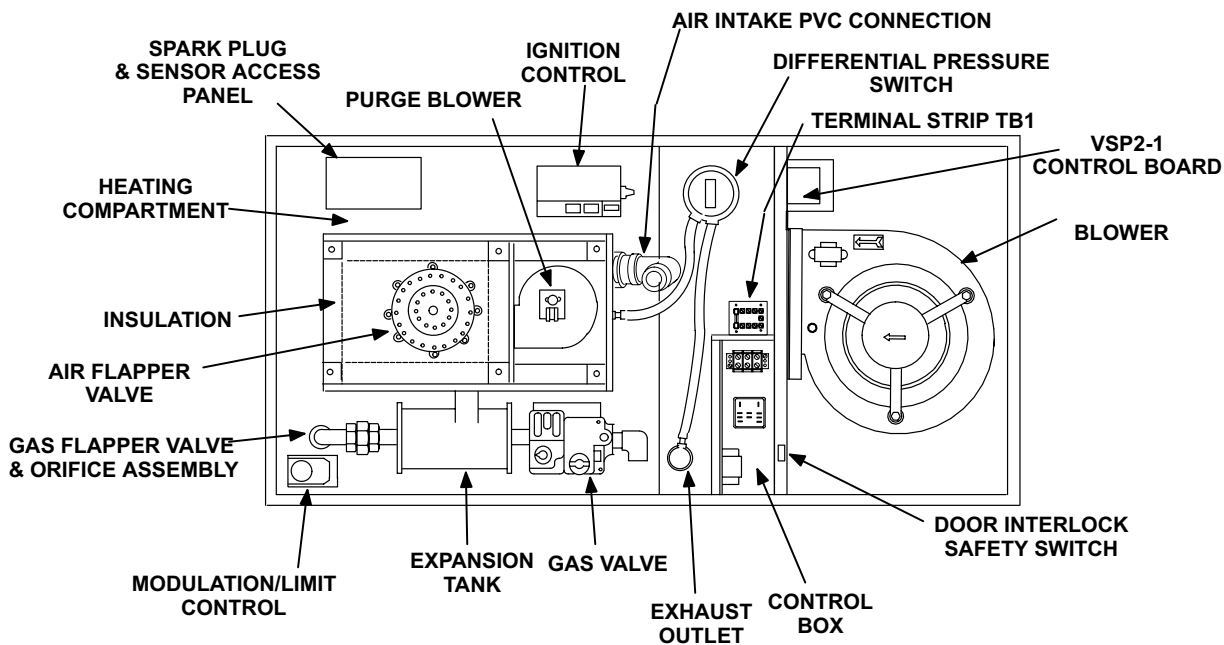

I - APPLICATION

G21/GSR21 unit input range covers 40,000 through 100,000 Btuh. See specifications table.

G21/GSR21 models use the same cabinet size as the existing G14/GSR14 furnace line. All units in the G21/GSR21 series use direct drive blowers and accept cooling coils in nominal tonnages up to 5 tons for the -80, -100. Consult the Engineering Handbook for proper sizing. Slab filters are used for either bottom or side return air in G21 models and top return air in GSR21 models.

II - UNIT COMPONENTS

A - Control Box (Figures 1 and 2)

The G21 control box is located below the air intake chamber. -40, -60 and -80 control boxes are designed to open over the exhaust PVC line when the unit is set up for right-hand discharge of exhaust. -100 control boxes are designed to open over the exhaust PVC line when the unit is set up for left-hand discharge of exhaust.

The GSR21 control box is located in the lower right-hand corner of the heating compartment in horizontal installations and in the upper right-hand corner of the heating compartment in reverse flow applications.

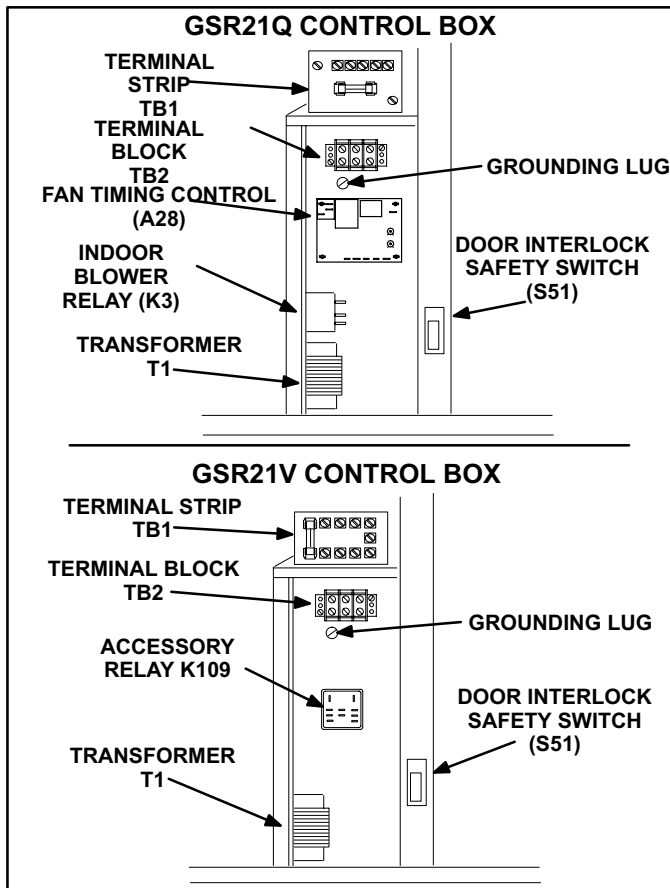

FIGURE 1

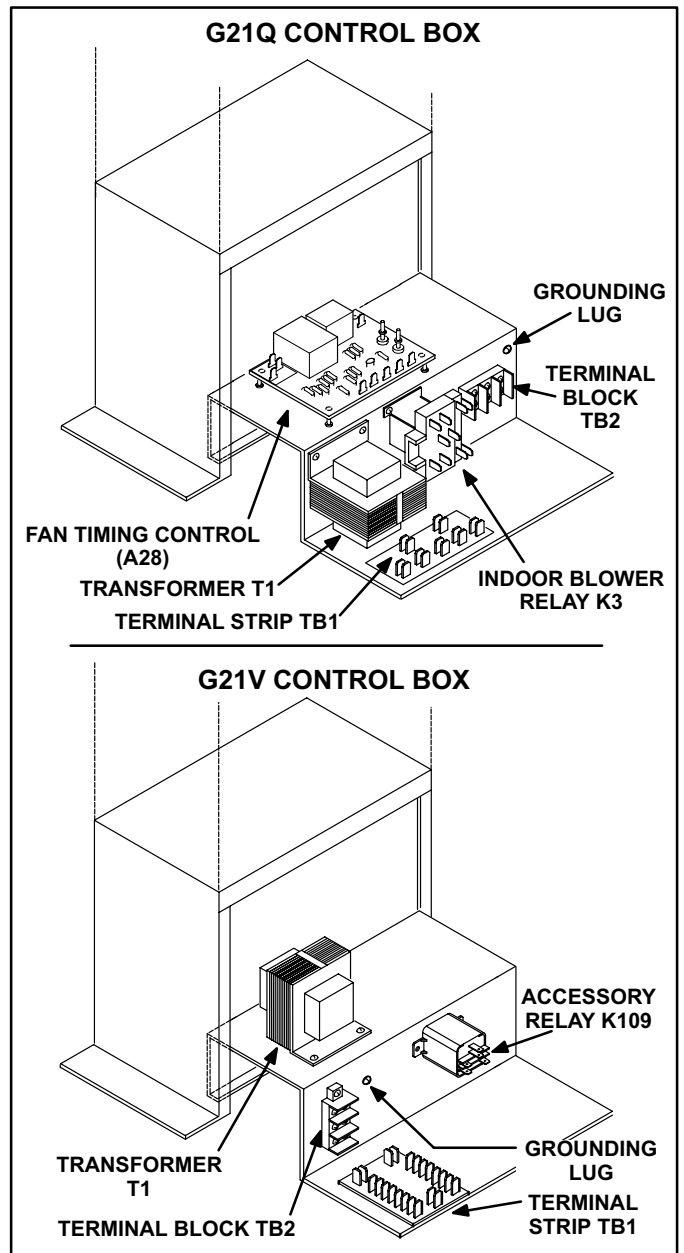

FIGURE 2

1 - Control Transformer T1

A transformer (T1) located inside the control box provides power to the low voltage section of the unit. Transformers are rated at 30VA for "Q" models and 50VA for "V" models with a 120V primary and 24V secondary.

2 - Transformer Fuse F1

Transformer T1 is protected by a fuse F1. See table 1 for fuse ratings. The fuse is located on the TB1 terminal strip.

TABLE 1

APPLICATION	TRANSFORMER FUSE	
	F1	FUSE RATING
"V" MODELS		3 AMP MDX SLOW BLOW
"Q" MODELS		2 AMP AGC FAST BLOW

3 - Low Voltage Terminal Strip TB1

A low voltage terminal strip (TB1) with thermostat markings is located outside the control box. See figures 3, 4 and 5.

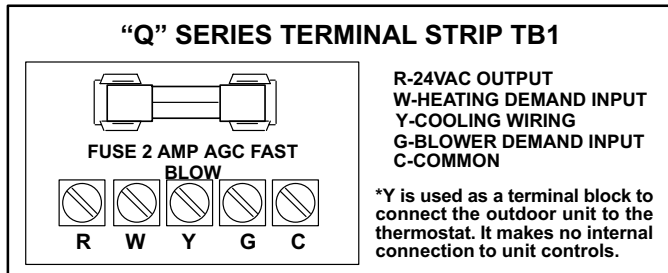

FIGURE 3

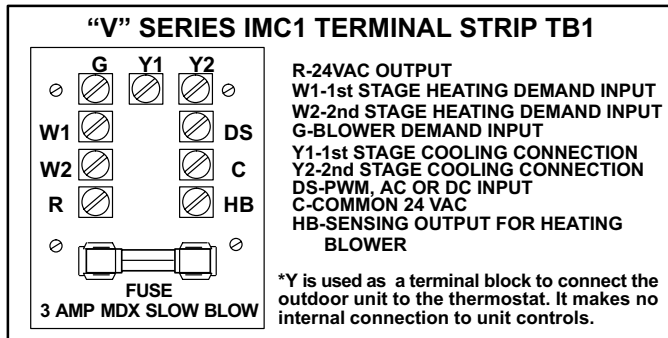

FIGURE 4

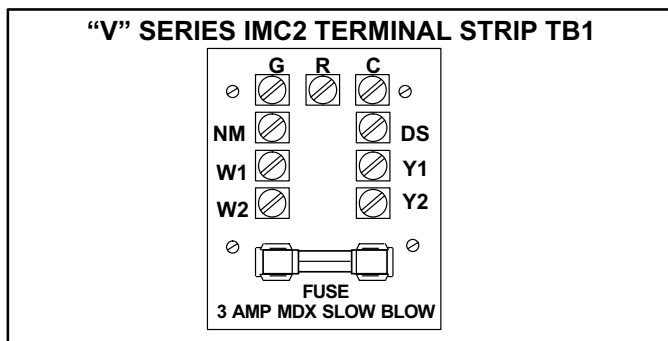

FIGURE 5

The following terminal designations are unique to "V" series with the **IMC1** motor:

"R" This signal provides 24VAC to the thermostat and, in zoning applications, to the zone control.

"DS" This is the speed regulation input that switches the blower from LOW to HIGH speed in cooling mode. DS is the PWM (pulse width modulation) input in zoning applications. When used with the CCB1 it is a 12-17VDC signal. When used without the CCB or Harmony it is a 24 VAC signal from the thermostat.

"HB" This is an output signal, to tell the zone control when the electronically controlled blower is energized from either a heating demand or a tripped secondary limit.

The following terminal designations are unique to "V" series units with the **IMC2** motor:

"R" This signal provides 24VAC to the thermostat and, in Harmony II zoning applications, to the control center.

"DS" This is the speed regulation input that switches the blower from LOW to HIGH speed, in cooling mode. DS is the PWM (pulse width modulation) input in zoning applications that use Harmony II zoning system.

"NM" This terminal is used for non-zoning (Non-Harmony), non-modulating applications where heat exchanger modulation is **NOT** desired. The heat demand from the thermostat should be wired to this terminal **instead** of W1.

CAUTION

For units with the IMC2 motor do not connect the heat demand wire to both the W1 and the NM terminals. Damage to the unit will occur. Use the W1 terminal for zoning (Harmony) applications and the NM terminal for non-zoning (Non-Harmony) applications.

"W1" This terminal is used for zoning (Harmony) modulating applications where heat exchanger modulation **IS** desired. This terminal is also used for the first stage of a two-stage heating application.

"W2" This terminal is used for two-stage heating. Two-stage heating is not available when using the non-modulating **NM** terminal.

For field wiring to terminal strips see figures 3, 4 and 5. See tables 2 and 3 for jumper connections.

TABLE 2
IMC1 MOTOR

TB1 TERMINAL STRIP JUMPERS "V" MODELS	
APPLICATION	JUMPERS REQUIRED
Single Stage Heating	"HB" Jumpered to "W2"
Single-Speed Compressor, No CCB1, Without Harmony	"DS" Jumpered to "G"
Two-Speed Compressor, No CCB1, Without Harmony	"DS" Jumpered to "Y2"
CCB1 With Single-Speed or Two-Speed Compressor, Without Harmony	No Jumpers Required*

*Never Jumper "Y2" to "DS" when a CCB1 control is used. Damage to the CCB1 will occur.

TABLE 3
IMC2 MOTOR

TB1 TERMINAL STRIP JUMPERS "V" MODELS	
APPLICATION	JUMPERS REQUIRED
Single Stage Heating	See Figure 13 For Pin Setting
Single-Speed Compressor, No CCB1, Without Harmony	"DS" Jumpered to "G"
Two-Speed Compressor, No CCB1, Without Harmony	"DS" Jumpered to "Y2"
CCB1 With Single-Speed or Two-Speed Compressor, Without Harmony	No Jumpers Required*

*Never Jumper "Y2" to "DS" when a CCB1 control is used. Damage to the CCB1 will occur.

NOTE For single stage heat application with the IMC2 motor VSP2-1 will have a selector pin for single or second stage heating. See figure 13.

Refer to tables 18 through 22 for a complete listing of all jumpers used.

If a two speed condensing unit is used and Harmony or CCB1 is not used jumper DS to Y2. The blower will operate on the low speed heat/cool tap during first stage cooling (low speed compressor). During second stage cooling (high speed compressor), the blower will operate on the high speed cooling tap. If a single speed condensing unit and no Harmony or CCB1 is used, jumper DS to G. The blower will operate on the high speed cooling tap during the cooling mode.

⚠ CAUTION

Never jumper "Y2" to "DS" if a CCB1 control is used. Damage to the CCB1 control will occur.

⚠ IMPORTANT

"Y2" must be jumpered to "DS" in two-speed, non-zoned application when CCB1 is not used.

4 - Terminal Block TB2 (Figure 6)

Line voltage is routed to the unit through a power supply terminal block (TB2) located inside the control box. The terminal block is energized at all times.

In "Q" units the accessory terminal (ACC) is energized any time there is a blower demand. In "V" units the accessory terminal is energized by the VSP control and is powered when the blower is running.

The accessory terminal can be used for accessories such as an electronic air cleaner.

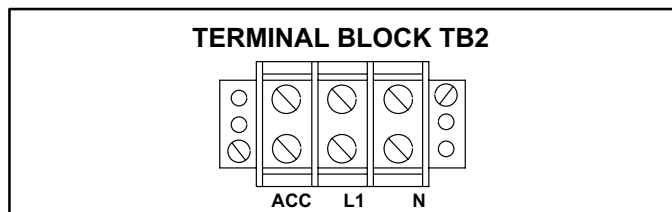

FIGURE 6

5 - K3 Indoor Blower Relay "Q" Models Only

A double-pole, double-throw indoor blower relay is located inside the control box to provide power to the blower. K3 relay contacts also control the 120V accessory terminal located on terminal strip TB2.

6 - Watchguard Control Board (A18) GC1 Control Only

The watchguard control board is illustrated in figure 7. Watchguard serves as an automatic electronic ignition reset device. Watchguard is a N.C. SPST self-resetting timer wired in series with W1 thermostat demand. It is built into the ignition control on all units equipped with GC-3 or Johnson ignition control. On GC-1 equipped units it is externally mounted.

For GC-1 equipped units Watchguard is enabled with a heating demand. After one hour (unit locked out or running) of continuous thermostat demand, watchguard opens for two minutes then closes remaking the rmostat demand W1. This resets electronic ignition control A3. After this break, a thermostat demand for heat will allow the unit to fire. If ignition is not successful unit lockout occurs. If successful the unit operates. Lockouts are usually attributed to low gas line pressure. For units equipped with a GC-3 or Johnson ignition control, the Watchguard is enabled only after the unit locks out because of failed ignition attempts (five tries). The watchguard will then break and remake the rmostat demand after one hour.

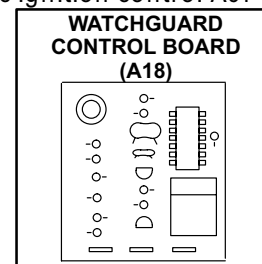

FIGURE 7

7 - Fan Timing Control A28 "Q"Units Only (Figure 8)

A fan timing control (A28) located in the control box is used in "Q" models to regulate fan-on and fan-off timings. Fan-on timing is the amount of time that the unit operates in a heating demand without the blower running during initial start up. Fan-off timing is the amount of time that the blower continues to run after heating demand has been terminated. Fan timing control part number 51K4601 (figure 8) has a factory set fan-on time of 45 seconds and is adjustable from 30 to 60 seconds. Fan-off timing is factory set at 180 seconds and is adjustable from 120 to 240 seconds. Fan timing control with early part number 76H31 has a fan-on timing set at 45 seconds and is not adjustable. Fan timing control with part number 97H03 and 79J65 has an adjustable fan-on timing from 30 to 60 seconds. Fan-off timing is factory set at 180 seconds and is adjustable from 120 through 240 seconds. During fan-off timing blower operates on low speed heat/cool tap.

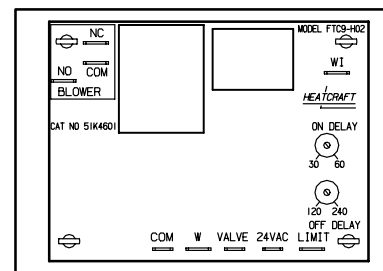

FIGURE 8

8 - K9 Isolation (Heat) Relay “Q” Models Only

Fan timing control (A28) with part number 79J65 contains a single-pole, single-throw isolation relay (K9). When there is a heat demand through W1, K9 is energized closing the normally open contacts K9-1 in the ignition circuit. The addition of an isolation relay in the W1 circuit will eliminate electrical noise feeding from the electronic thermostat back to the electronic ignition control.

9 - K109 Accessory Relay “V” Models Only G21V-5 to -8 & GSR21V-10 to -15

A single-pole, single-throw accessory relay is located inside the control box to provide power to additional accessories which may be used with the G21V / GSR21V.

10 - VSP1 Blower Control Board (A24) “V” Models Only G21V-1 to -3 & GSR21V-1 to -9 (Figure 9)

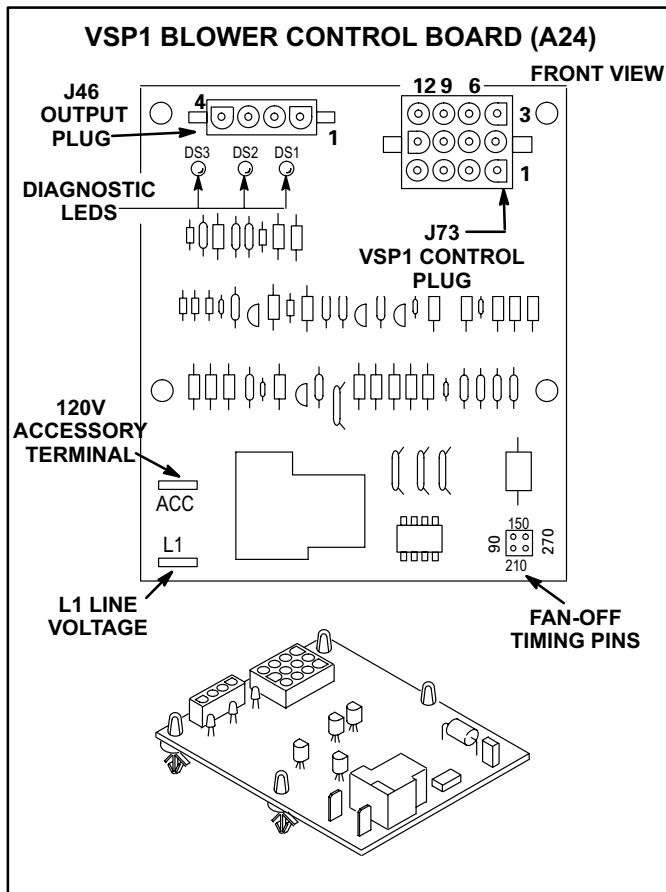

FIGURE 9

The VSP1 (A24), a printed circuit board located in the control box, serves four primary functions:

- 1- Controls blower timings during heating to accommodate the required initial heat-up and cool-down times of the heat exchanger.

- 2- Senses limit trip condition and turns on the blower.
- 3- Controls the accessory relay.
- 4- Interfaces the 24VAC thermostat with the blower.

When operating in heating mode, VSP1 controls the blower and monitors limit and gas valve operation. The VSP1 controls the “fan-on” and “fan-off” timings. Fan-on timings are pre-set and non adjustable. Fan-off timings are adjustable. Fan-on timing is the amount of time the unit operates before the blower is started. This period allows for heat exchanger warm-up. The fan-on timing is pre-set at 45 seconds and is not adjustable.

Fan-Off timings (time that blower operates after heating demand has been satisfied) are determined by the arrangement of a jumper on the VSP1 board. To adjust fan-off timings, gently disconnect jumper and reposition it across pins corresponding with new timing (see figure 10). The fan-off timing is factory set at 270 seconds.

! IMPORTANT

If fan-off time is too low, residual heat in heat exchanger may cause primary limit S10 to trip resulting in frequent cycling of blower. If this occurs, adjust blower to longer time setting.

! DANGER



Shock Hazard. VSP1 fan control is connected to line voltage. Disconnect power to unit before changing pin timings. Can cause personal injury or control damage.

FAN-OFF TIME ADJUSTMENT

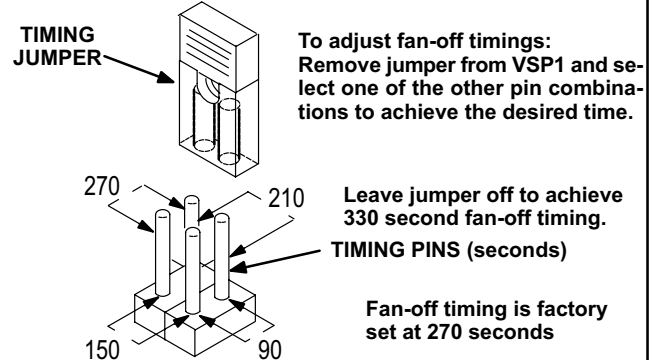

FIGURE 10

The VSP1 includes a 120 VAC accessory terminal. The terminal is wired directly to terminal block TB2 and powers the accessory connection on the terminal block. The terminal is energized when the blower is running. It can be used for any desired accessory equipment such as an electronic air cleaner or humidifier.

VSP1 provides an interface between the 24VAC indoor thermostat signal and the direct current digital signal to the blower motor. The control is responsible for energizing the blower motor in response to thermostat demand and for converting thermostat demand from 24VAC to 24VAC half rectified (DC pulse) see figure 11. The motor controller (inside the blower motor) is responsible for regulating blower speed to maintain the desired CFM.

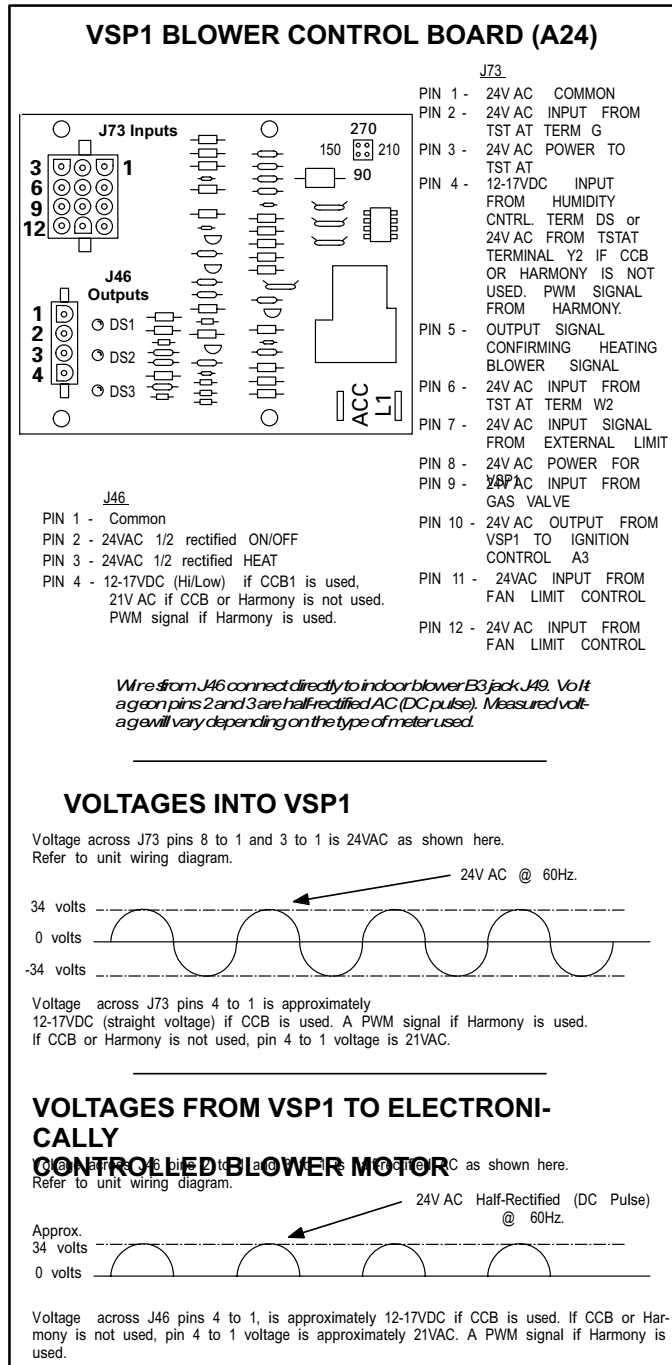

FIGURE 11

! IMPORTANT

24 VAC half wave rectified (DC pulse), when measured with a meter, may appear as a lower or higher voltage depending on the make of the meter. Rather than attempting to measure the output voltage of A24, see G21V/GSR21V "V" BLOWER AND VSP1 BLOWER CONTROL BOARD TROUBLESHOOTING FLOW CHART in the TROUBLESHOOTING section of this manual.

Diagnostic LED Lights

Three diagnostic LED lights are provided on the control for troubleshooting. The three lights DS1, DS2 and DS3 (figure 12) are "on/off," "hi speed heat" and "high speed cool." In the heating and cooling mode, the on/off LED (DS1) is lit indicating the blower is operating on low speed heat/cool tap. It is lit whenever a 24VAC thermostat demand is supplied to the control (jackplug JP73 pin 2). When the "hi speed heat"(DS2) and the on/off (DS1) LED are both lit the blower is operating on high speed heating tap (12-17VDC from CCB1 terminal DS or 24VAC from Y2 if CCB1 is not used). During dehumidification mode, the CCB1 turns off the DS output and the blower operates on low speed heat/cool tap. When the "high speed cool" (DS3) and the "on/off" (DS1) LED are both lit the blower is operating on high speed cool tap.

If the unit is switched from a heating demand to a 2nd stage cooling demand, all three lights (DS1, DS2 and DS3) may be energized for a short time. During this period, blower operates on high speed heating tap.

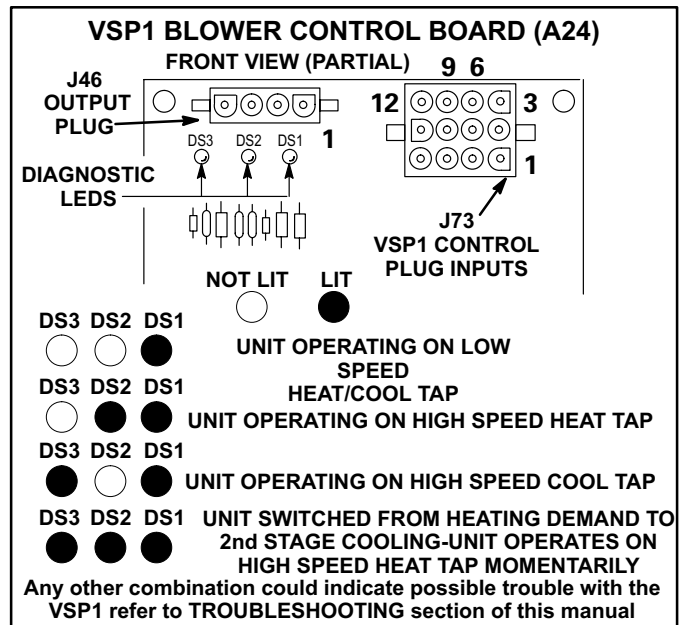

FIGURE 12

B - VSP2 Blower Control Board (A24)
“V” Models Only G21V-5 to -8 & GSR21V
-10 to -15 (Figure 13)

⚠ IMPORTANT

If fan-off time is too low, residual heat in heat exchanger may cause primary limit S10 to trip resulting in frequent cycling of blower. If this occurs, adjust blower to longer time setting.

G21V / GSR21V units are equipped with a variable speed motor that is capable of maintaining a specified CFM throughout the external static range. The unit uses the VSP2-1 variable speed control board, located in the blower compartment, which controls the blower speed and provides diagnostic LEDs. The control has both a non-adjustable, factory preset “ON” fan timing delay and an adjustable “OFF” fan timing delay (see figure 15).

The VSP2-1 also senses limit trip condition and turns on the blower. The G21V / GSR21V limit switch is located in the vestibule wall. When excess heat is sensed in the heat exchanger, the limit switch will open and interrupt the current to the gas valve, while at the same time the VSP2-1 energizes the blower on heating speed. The limit automatically resets when the unit temperature returns to normal and the blower is de-energized.

Diagnostic LEDs located on the VSP2-1 control board are provided to aid in identifying the unit's mode of operation. Certain scenarios will arise depending on the jumper positions.

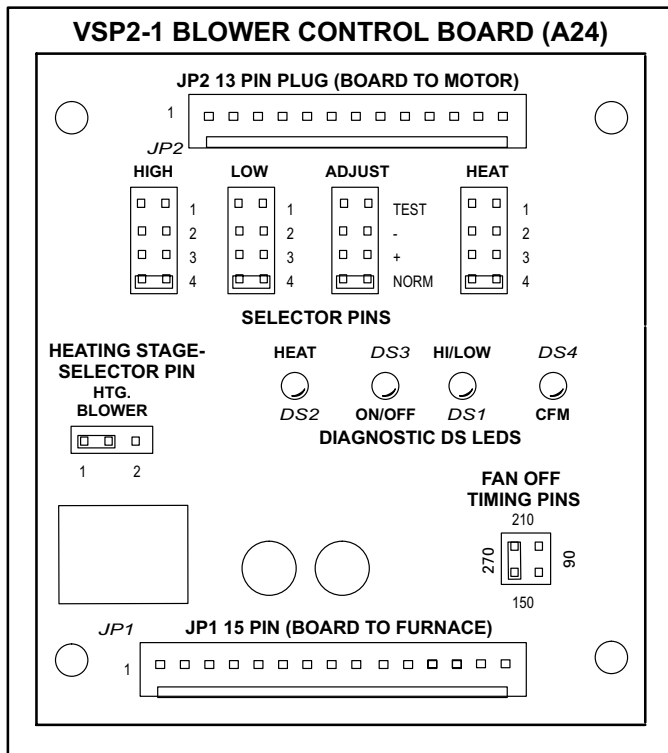

FIGURE 13

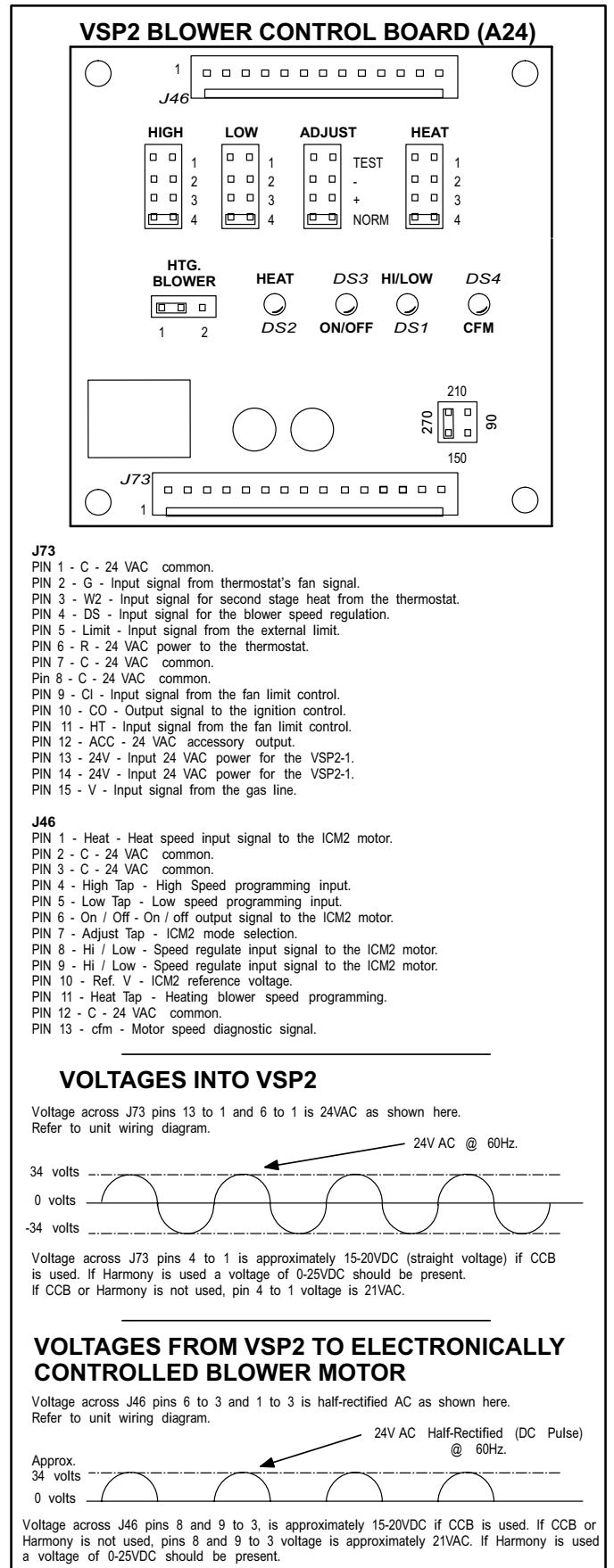

FIGURE 14

! IMPORTANT

24 VAC half wave rectified (DC pulse), when measured with a meter, may appear as a lower or higher voltage depending on the make of the meter. Rather than attempting to measure the output voltage of A24, see G21V/GSR21V “V” BLOWER AND VSP2 BLOWER CONTROL BOARD TROUBLESHOOTING FLOW CHART in the TROUBLESHOOTING section of this manual.

Diagnostic LED Lights

1 - DS3 “ON/OFF”

ON/OFF-DS3 indicates there is a demand for the blower motor to run. When the **ON/OFF** LED-DS3 is lit, a demand is being sent to the motor. In heating mode only, there is a 45 second fan “ON” delay in energizing **ON/OFF** LED-DS3. The light will not go off until adjustable fan “OFF” delay has expired.

If **ON/OFF** LED-DS3 is on and both **HIGH/LOW** LED-DS1 & **HEAT** LED-DS2 are off, the motor will operate in low speed.

a - DS2 “HEAT”

If **HEAT** LED-DS2 is on, the blower is running in the heat speed according to the “HEAT” jumper setting. In heating mode only, there is a 45 second delay in energizing **HEAT** LED-DS2. Light will not go off until adjustable fan “OFF” delay has expired.

b - DS1 “HI/LOW”

HIGH/LOW LED-DS1 indicates whether the blower is operating in high or low speed. When the light is off, the blower is running in low speed according to the “LOW” jumper setting. When **HIGH/LOW** LED-DS1 is on, the blower is operating in high speed according to the “HIGH” jumper setting.

c - DS4 “CFM”

CFM LED-DS4 indicates the CFM the unit is operating, according to the jumper settings. The light flashes once for approximately every 100 CFM. For example, if the unit is operating at 1000 CFM, **CFM** LED-DS4 will flash 10 times. If the CFM is 2050, **CFM** LED-DS4 will flash 20 full times plus one fast or half flash.

At times the light may appear to flicker or glow. This takes place when the control is communicating with the motor between cycles. This is normal operation.

The appropriate speed according to application and CFM need is selected by moving jumper pins.

NOTE-On Harmony II zoning applications in the heating mode, the highest speed obtainable is the same as the highest cooling speed selection. Also, the heating speed (heat jumper position) is only used when the primary limit has been tripped. In non-zoning applications, refer to the section on the VSP2-1 control.

Jumper Settings

! IMPORTANT

Before changing jumper setting, make sure the motor has completely stopped. Any jumper setting change will not take place while the motor is running.

To change jumper positions, gently pull the jumper off the pins and place it on the desired set of pins. The following section outlines the different jumper selections available and conditions associated with each one. Refer to figure 13 for identification.

After the CFM for each application has been determined, the jumper settings must be adjusted to reflect those given in the tables on pages 7 and 8. Using the tables, determine which row of CFM volumes most closely matches the desired CFM. Once a specific row has been chosen (+, NORMAL, or -), CFM volumes from other rows cannot be used. Below are the descriptions of each of the jumper selections.

Refer to table 4 for factory settings. Refer to the tables on pages 7 and 8 for the approximate air volume for each setting.

**TABLE 4
VSP2-1 FACTORY SETTINGS**

MODEL NUMBER	HIGH	LOW	ADJUST	HEAT
G21V5-80 G21V3-60	4	1	NORM	1
G21V5-100 G21V3-80	4	1	NORM	2
GSR21V5-80	4	1	NORM	1
GSR21V5-100	4	1	NORM	2

a-“ADJUST”

The **ADJUST** pins allow the motor to run at normal speed, approximately 10% higher, or approximately 10% lower than normal speed. The tables on pages 7 and 8 give three rows (+, NORMAL, and -) with their respective CFM volumes. Notice that the normal adjustment setting for heat speed position #3 in the G21V5-80/100 blower data table is 2080 CFM. The + adjustment setting for that position is 2270 CFM and for the - adjustment setting is 1860 CFM. After the adjustment setting has been determined, chose the remainder speed jumper settings from those offered in the table.

The TEST pin is available to bypass the VSP2-1 control and run the motor at approximately 70% to test that the motor is operational. This is beneficial primarily in troubleshooting. G must be energized for motor to run.

b-“HEATING BLOWER”

Place the **HEATING BLOWER** jumper across the first and second pins for single-stage heating operation (position #1). For two-stage operation, place the jumper across the second and third pins (position #2).

The position of the jumper determines which set of speed jumpers is activated. When the **HEATING BLOWER** jumper is across the first and second pins, the **HEAT** jumper selections are activated when W1 is energized.

If the jumper is across the second and third pins, the **LOW** jumper selections are activated when W1 is energized. **HEAT** jumper selections are activated when W2 is energized.

NOTE-If Harmony II zoning applications, HEATING BLOWER jumper must be in position #2

c-“HEAT”

The **HEAT** jumper is used to set the blower speed to obtain the required CFM as outlined in HEAT SPEED section of the tables on pages 7 and 8.

If a lower heating speed (than one that is listed in HEAT SPEED section) is required, the **LOW** jumper may be used to set the heating speed. This is done by first placing the **LOW** jumper in the desired CFM position and then placing the **HTG. BLOWER** jumper across the second and third pins (regardless of the actual stage). Doing so will activate the low speed jumper setting when W1 is energized.

d-“HIGH”

The **HIGH** jumper is used to determine the CFM during cooling speed. These jumper selections are activated when G and DS terminals are energized.

e-“LOW”

The **LOW** jumper is used to determine CFM during low speed cooling. These jumper selections are activated when G is energized. The **LOW** jumper may also be used for low speed heating. See the “HEAT” section for details.

f-FAN “OFF”

Fan “OFF” timings (time that the blower operates after the heat demand has been satisfied) are determined by the arrangement of a jumper on the VSP2-1 board. See figure 15. To adjust fan “OFF” timings, gently disconnect the jumper and reposition it across pins corresponding with the new timing. Fan “OFF” time is factory set at 270 seconds. Fan “ON” time is factory set at 45 seconds and is not adjustable.

WARNING - MAKE SURE TO DISCONNECT POWER BEFORE CHANGING FAN “OFF” TIMINGS.

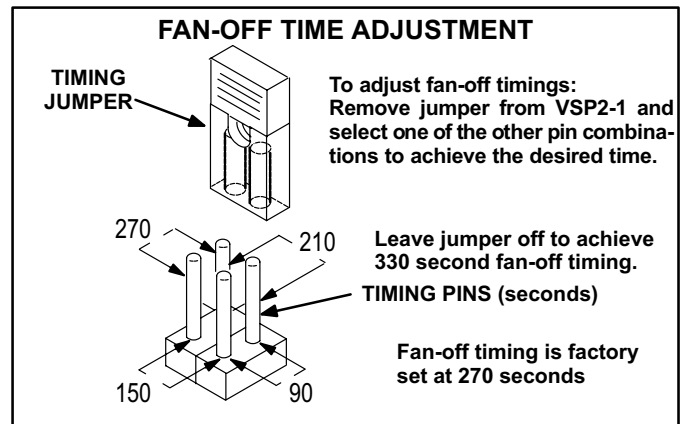

FIGURE 15

NOTE—If the “OFF” time is too low, residual heat in heat exchanger may cause primary limit S10 to trip resulting in frequent cycling of blower. If this occurs, adjust blower to long time setting.

C - Limit Control-Modulation/Limit Control (Figure 16)

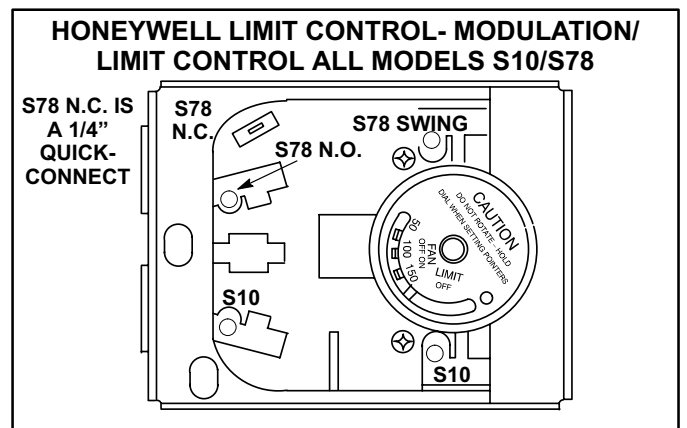

FIGURE 16

1 - Limit Control (S10) “Q” Models

G21Q/GSR21Q models use a Honeywell limit control. See unit components illustration (page 11) for exact location. If heat exchanger temperatures rise above limit setting (see table 5), the self-resetting limit interrupts power to ignition control A3, and fan timing control A28 will maintain the blower to cool down the unit. This is a safety shut down function. S10 automatically resets when temperatures inside the heat exchange assembly drop below limit setting. Do not change factory limit setting. S10 is set to limit maximum discharge air temperature.

TABLE 5

FAN/LIMIT CONTROL "Q" MODELS	
UNIT	LIMIT SETTING
G21Q3-40	200°
G21Q3/4-60	160°
G21Q3-80	210°
G21Q4/5-80	200°
G21Q3-100	230°
G21Q4/5-100	210°
GSR21Q3/4-50	170°
GSR21Q3-80	170°
GSR21Q4/5-80	160°
GSR21Q4/5-100	160°

TABLE 6

MODULATION CONTROL S78 "V" MODELS		
UNIT	MODULATION SETTING	
	OPEN	CLOSE
G21V3-60	140°F	110°F
G21V3-80	145°F	115°F
G21V5-80	135°	105°F
G21V5-100	140°F	110°F
GSR21V3-80	140°F	110°F
GSR21V5-80	130°	100°
GSR21V-100	130°	100°

F

F

2 - "V" Modulation/Limit Control (S78/S10)

G21V/GSR21V units use a Honeywell combination modulation/limit control. The limits are located in the same housing. See unit components illustration (page 11).

a - Modulation Control S78

Modulation limit control (S78) is a self-resetting SPDT limit wired in series with ignition control A3. See table 6 for modulation settings. For units equipped with the VSP2 with the heating blower jumper in position 1 and the thermostat wired to W1 in a single-stage application, the blower will operate on the low speed (heat/cool) tap. For units equipped with the VSP1 and the thermostat wired to W1 in a single stage application, the blower will operate on the low speed (heat/cool) speed tap. Heat exchanger temperatures will rise to modulation settings due to the low air flow across heat exchanger. S78 will open interrupting power to gas valve GV1. VSP (1 or 2) control board activates blower on low speed (heat/cool) tap. Residual heat in heat exchanger is used for heating. S78 closes when heat exchanger temperatures drop below modulation setting. If there is a thermostat demand, A3 will cycle through a normal ignition timing sequence.

For units equipped with the VSP2 and the heating blower jumper in position 2, the blower will operate on heat speed tap. Cycling will occur less frequently due to increased air flow across heat exchanger.

Use the "NM" non modulating terminal instead of the "W1" for single stage non-zoning applications where modulating is not desired. For units equipped with the VSP1, and W2 and HB jumpered together, the blower will operate on high speed tap. Regardless of VSP used do not change the factory modulation settings. S78 is set to prevent the unit from tripping limit S10.

! IMPORTANT

VSP2

The heating blower jumper must be in position number 2 if a single stage thermostat is to be used and heat speed is desired. This forces the blower to run on the high speed heat tap and stops frequent cycling which would occur. When the blower operates on the low speed heat tap, reduced airflow causes heat exchanger temperatures to rise above the modulation control (S78) setpoint. The limit will "trip" terminating thermostat demand. The blower continues to run and as temperatures decrease the limit resets. Thermostat demand is remade.

! IMPORTANT

VSP1

If a single stage thermostat is to be used, "HB" and "W2" terminals must be jumpered together. This forces the blower to run on the high speed heat tap and stops frequent cycling which would occur. When the blower operates on the low speed heat tap, reduced airflow causes heat exchanger temperatures to rise above the modulation control (S78) setpoint. The limit will "trip" terminating thermostat demand. The blower continues to run and as temperatures decrease the limit resets. Thermostat demand is remade.

b - Limit Control S10

If heat exchanger temperatures keep rising, limit control S10 will open. S10 is a self-resetting N.C. limit wired in series with the thermostat. S10 opens on a temperature rise interrupting power to thermostat, terminating heating demand. See table 7 for limit settings. VSP2 control board activates blower on low speed (heat/cool) tap.

S10 automatically closes when heat exchanger temperatures drop below limit setting. If there is a heating demand, ignition control A3 cycles through a normal ignition timing sequence. Do not change factory limit setting. S10 is set to limit maximum discharge air temperature. This is a safety shut down function.

TABLE 7

LIMIT CONTROL S10 "V" MODELS	
UNIT	LIMIT SETTING
G21V3-60	180°
G21V3-80	180°
G21V5-80	200°
G21V5-100	220°
GSR21V3-80	170°
GSR21V5-80	170°
GSR21V5-100	160°

F

D - Secondary Limit S21 (Reverse Flow Units Only) Figure 17

S21 is a SPST N.C. manual reset limit wired in series with ignition control A3. It is located on the blower housing. If the blower should fail to operate or if return or supply airway becomes partially blocked, the blower housing would become warm causing S21 to "trip." S21 is set at 160° F and cannot be adjusted. If S21 trips, it must be manually reset. Allow adequate time for S21 to cool before attempting to reset. CGA models use a self-resetting SPST N.C. limit that opens at 130° F and closes at 110° F. Its function is the same. This is a safety shut down function of the unit.

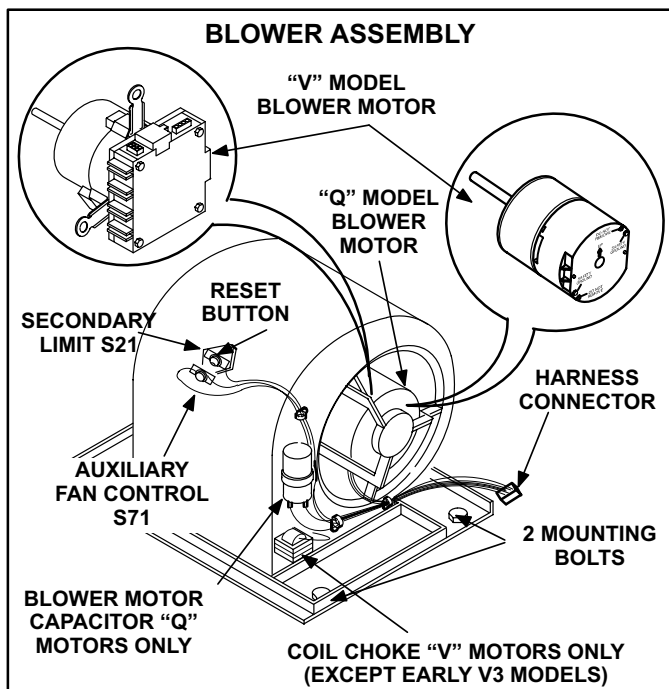

FIGURE 17

E - Auxiliary Fan Control (S71) (Reverse Flow Units Only) Figure 17

An auxiliary fan control (S71) is located on the blower housing. It protects secondary limit (S21) from "tripping." S71 actuates at 140° F. In both Q and V units, if S71 actuates (closes) the blower is forced to operate.

1 - GSR21 "Q" Applications (S71)

S71 is a normally open SPST self-resetting control wired in parallel with blower relay K36-1. On a temperature rise S71 closes energizing blower B3 on heating tap speed.

2 - GSR21 "V" Applications (S71)

S71 is a normally open SPST self-resetting control wired in series with 24 VAC from transformer T1. S71 closes and S78 opens on a temperature rise (see table 6). When S71 closes, pin 11 on the VSP2 and pin 12 on the VSP1 is energized. When S78 opens, pin 11 on the VSP2 and pin 12 on the VSP1 is energized. When pin 11 on the VSP2 or pin 12 on the VSP1 is energized, the blower operates on low speed (heat/cool) tap.

Secondary limit (S21) and auxiliary fan control (S71) work together to reduce excessive temperature in the blower end of unit. First, as temperature rises in the blower compartment and nears 140° F, S71 actuates the blower in an attempt to reduce temperature. If temperatures continue to rise, S21 will "trip" and ignition control A3 is de-energized.

⚠ DANGER

Shock Hazard. Auxiliary fan control is connected to line voltage. Before servicing control, be sure to disconnect power to unit. Can cause injury or death.

F - Ignition Control (A3)

An electronic direct spark ignition control (A3) with flame rectification sensing is used on all G21/GSR21 units. See figures 18 and 19. G21 and GSR21 series may be factory equipped with Lennox GC-1, Lennox GC-3, or Johnson G891 ignition control modules. Ignition controls are interchangeable. Refer to Service and Application Notes.

For additional safety and troubleshooting convenience, the ignition control modules self-test their internal safety circuits continuously and use the diagnostic LED to indicate control failure. The light helps the technician troubleshoot the unit by indicating an unusual condition.

⚠ IMPORTANT

When the GC-1 is operating normally the LED will **not** be lit. If it is lit refer to Ignition Control Troubleshooting Flowchart in the back of manual.

The GC-1 ignition control LED may be lit for the following reasons: lockout condition (lit), post-purge operation (lit) or control failure (lit). If the control is in lockout (lit) due to unsuccessful ignition (five tries), it must be reset by breaking and remaking thermostat demand or power to the unit. The GC-1 is equipped with a Safety Dormant Lockout circuit (sleep mode). This circuit continuously monitors the control for internal circuit faults. In addition the Safety Dormant Lockout circuit senses potentially damaging frequency, voltage or current. If lockout is due to a self-test failure, or if damaging frequency, voltage or current has been sensed, the GC-1 will go into a Safety Dormant Lockout (LED lit). The control will be shut off. The GC-1 control may or may not have been damaged. The control can only be reset by breaking and remaking power to the unit.

⚠ IMPORTANT

When the GC-3 and the G891 are operating normally the LED will be lit at all times. If it is not lit or if it is flashing refer to Ignition Control Troubleshooting Flowchart in the back of manual.

If any of the the GC-3 or the G891 model no. 86H3001 or 34K8301 control is in lockout (LED flashing) due to unsuccessful ignition (five tries), breaking and remaking thermostat demand or power to the unit will reset the control. The later G891 control (model no. 73K8601) has two flashing modes. If LED is flashing 0.5 seconds on and 2.5 seconds off, the control is in lockout due to unsuccessful ignition (five tries). To reset the control break and remake thermostat demand to the unit. If LED is flashing 0.1 seconds on and 0.1 seconds off (flickering) the control reads a low flame sense. Inspect sensor and refer to Troubleshooting Flowchart in back of manual. If the LED is not lit, break and remake power to unit. If LED is still not lit refer to Ignition Control Troubleshooting Flowchart in back of manual. The GC-3 and G891 do not have Safety Dormant Lockout circuit.

Watchguard

All G21 / GSR21 units are equipped with a watchguard circuit. The GC-1 uses a separate external watchguard WG1 control board (A18) located above the control box. The GC-3 and G891 ignition control incorporate this function.

The watchguard feature serves as an automatic reset device for ignition controls locked out because the furnace has failed to ignite.

The external watchguard used with the GC-1 ignition control will break and remake thermostat demand after one hour of continuous thermostat demand, (unit locked out or operational). This will reset the ignition control to attempt ignition.

The internal watchguard used with the GC-3 and the G891 is activated only when the unit has failed to light. The internal watchguard is activated after the fifth unsuccessful ignition trial. Internal watchguard will reset the ignition control one hour after the unit has locked out.

⚠ DANGER



Shock Hazard. Spark related components contain high voltage. Disconnect power before servicing unit. Ignition control is not field repairable. Can cause injury or death.

1 - Lennox GC-1 Ignition Control (Figure 18)

The Lennox-built GC-1 ignition control (A3) has a black plastic cover, and is illustrated in figure 18. The unit wiring harness (P72) plugs directly into the jack (J72) at the corner of the control. A diagnostic lockout indicator light, a red LED, is visible through the GC-1 cover.

Spark wire connection is made to a spark plug type connector on the control. Sensor wire connection is made to a quick connect terminal.

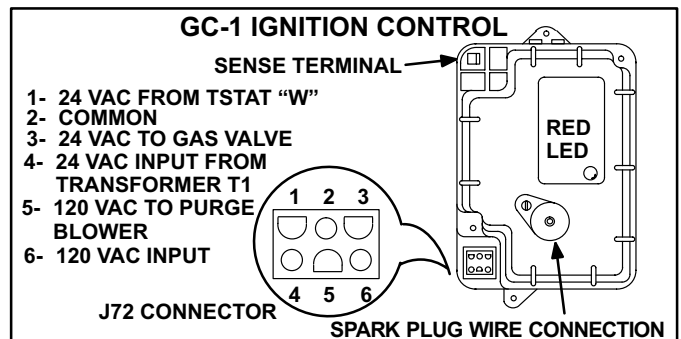

FIGURE 18

2 - Lennox GC-3 Ignition Control (Figure 19)

The Lennox-built GC-3 ignition control (A3) has a white or a green plastic cover, and is illustrated in figure 19. The unit wiring harness (P72) plugs directly into the jack (J72) at the bottom of the control. A diagnostic indicator light, a green LED, is visible through the GC-3 cover.

Spark wire connection is made to a barbed nail type connector on the control. Sensor wire connection is made to a 3/16" quick connect terminal opposite the barbed nail.

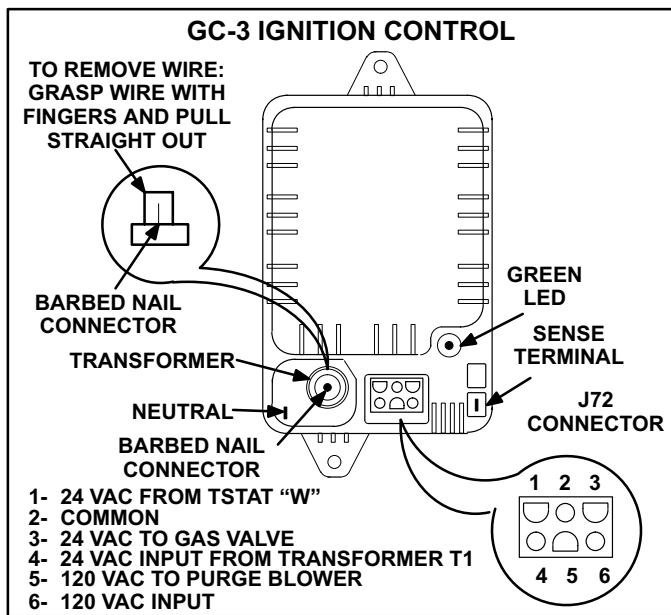

FIGURE 19

Three models of the GC-3 were made, early model (72H68-white cover) and later models (97H02-white cover and 52J18-green cover). The early model GC-3 stops spark as soon as a suitable flame is sensed, while the later model energizes the spark for a full eight seconds.

! IMPORTANT

A ceramic resistor spark plug must be used with Lennox ignition controls.

3 - Johnson G891 Ignition Control (Figure 20)

The Johnson G891 ignition control (A3) has a blue plastic cover, and is illustrated in figure 20. The unit wiring harness (P72) plugs directly into the jack (J72) at the bottom of the control. A diagnostic indicator light, a green LED, is located on the top center of the control, near the sense terminal.

Spark wire connection is made to a barbed nail type connector on the control. Sensor wire connection is made to a 3/16" quick connect terminal opposite the barbed nail. Like the later GC-3 controls the G891 energizes the spark for a full eight seconds.

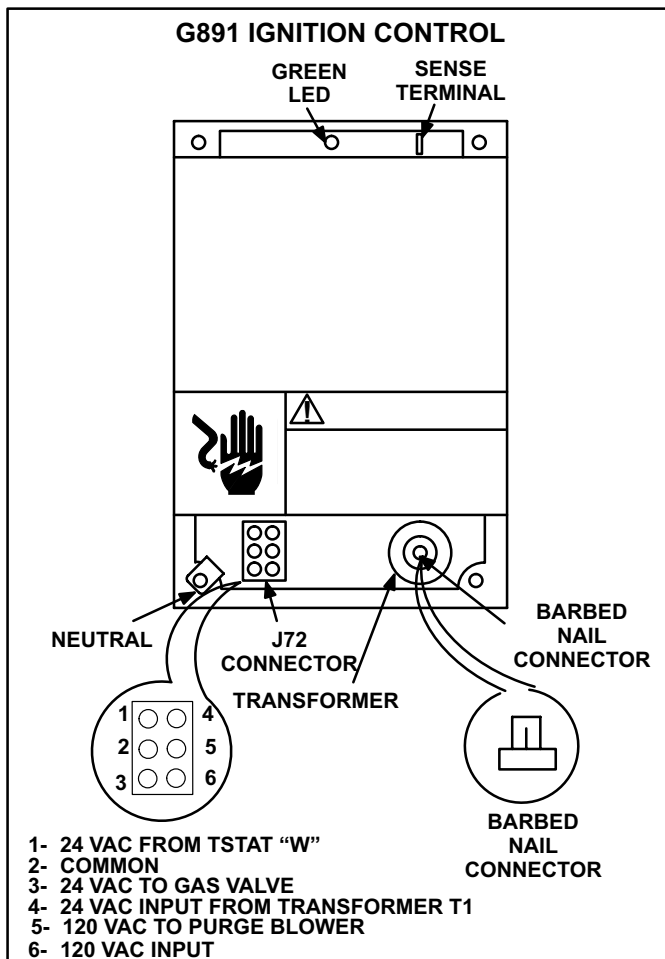

FIGURE 20

4 - Ignition Control Functions For GC-1, GC-3, and G891 (Figures 21 and 22)

The ignition control (A3) provides four main functions: pre-purge, ignition, flame sensing and post-purge. The ignition attempt sequence of the control provides five trials for ignition before lock out. See figure 21 for normal ignition sequence with nominal timings for simplicity.

Proper gas/air mixture is required for ignition on the first attempt. If there is slight deviation, within tolerance of the unit, a second or third trial may be necessary for ignition.

The control will lock out the system if ignition is not obtained within five trials. Reset after lockout requires only breaking and re-making the thermostat demand. Watchguard will automatically re-attempt ignition after one hour if there is still a thermostat heating demand. See figure 22 for the ignition attempt sequence for retrials (nominal timings given for simplicity). Loss of combustion during a heating cycle is sensed through absence of flame signal causing the control to de-energize the gas valve and repeat the ignition sequence if a thermostat heating demand is present.

Ignition control timings (timing specific) are given in figure 22.

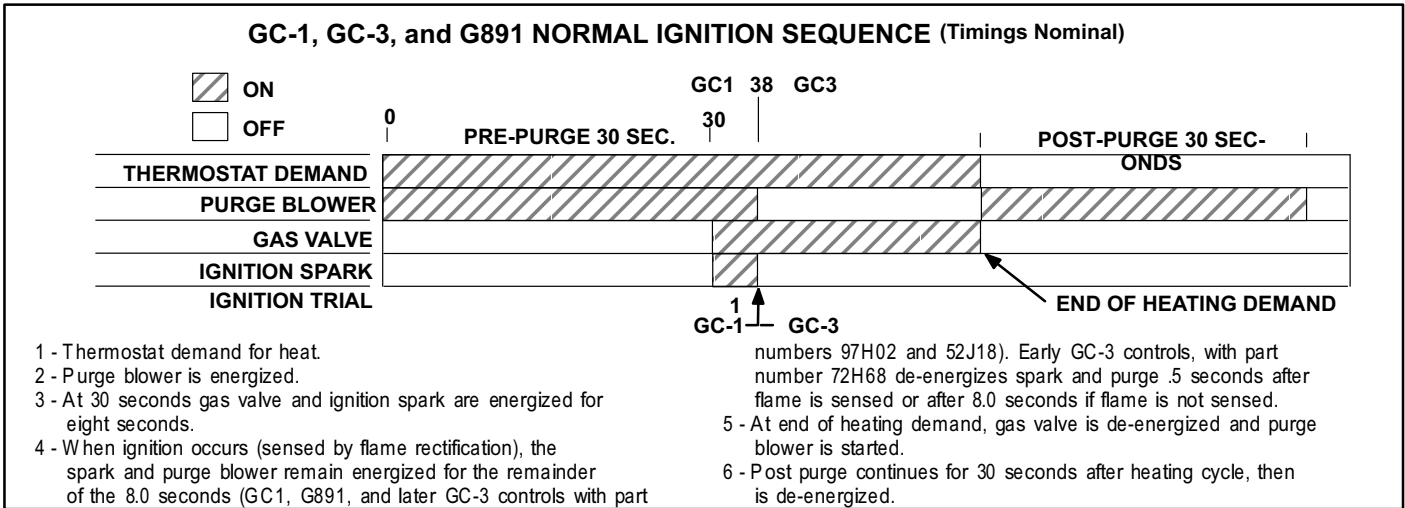

FIGURE 21

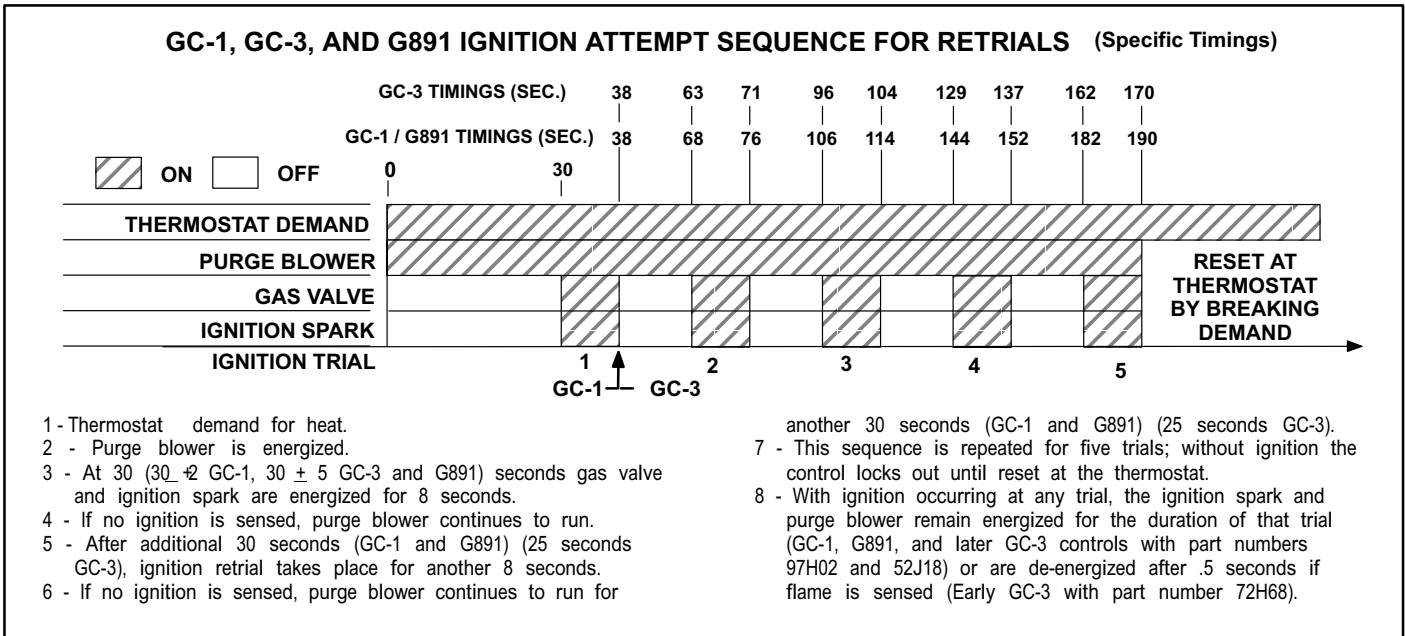

FIGURE 22

G - Gas Valve and Expansion Tank (Figure 23)

1 - Gas Valve

Gas valves used on G21/GSR21 series units have various opening times. All gas valves are internally redundant to assure safety shutoff. If replacement is necessary, the valve must be replaced with the same type of valve. For example, replace a White Rodgers as shown in figure 23 with a White Rodgers valve.

2 - Expansion Tank

An expansion tank downstream of the gas valve absorbs back pressure created during combustion to prevent damage to gas valve diaphragm.

3 - Gas Valve Conversion (Figure 24)

A gas changeover kit is available to convert A.G.A. / C.G.A. natural gas units to LP gas. Refer to the instructions provided in each specific kit for proper installation procedures.

A.G.A. / C.G.A. GSR21 (-50,-80) units are shipped with the components required for field conversion to LP gas.

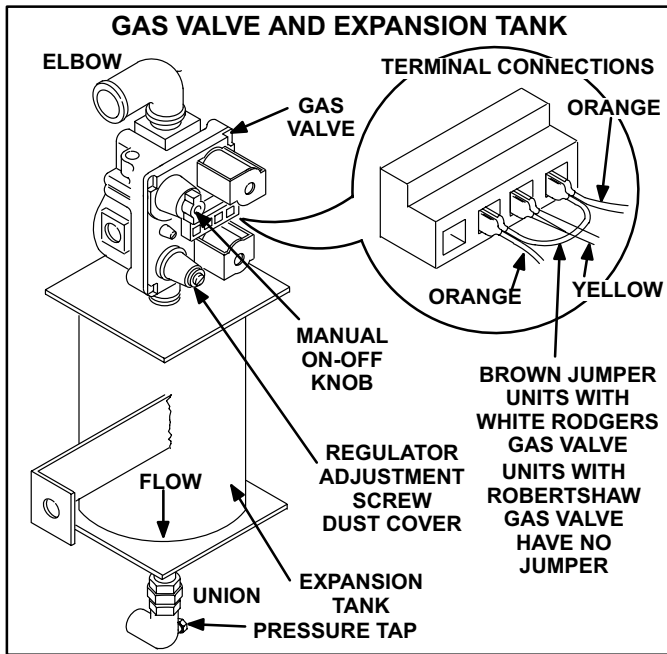

FIGURE 23

A.G.A. / C.G.A. GSR21-100 units are not shipped with the required components for field conversion to LP gas. An optional LP gas changeover kit is available from Lennox Repair Parts. G21 (upflow) units are not shipped with the required components for field conversion to LP gas. An optional LP changeover kit is available from Lennox Repair Parts.

The kit includes one orifice, one gas valve conversion kit with heavy spring, one air diaphragm assembly (if necessary with that model) and changeover nameplate.

The following is a general guide for conversion to LP Refer to the instructions provided in each specific kit for proper installation procedures.

The existing gas orifice located in the elbow/gas flapper assembly must be removed and replaced with the orifice provided in the kit. GSR21 (-50,-80) use orifice provided with unit. See figure 24.

A spring behind the adjusting screw and regulator cover screw must be replaced by a heavier spring also included in the kit. GSR21 -50 and -80 units regulator screw must be rotated so that end labeled "LP" points toward regulator. See figures 24 and 25.

In G21/GSR21-100 and G21-40 units the air diaphragm must be replaced (supplied with kit). For G21-60/80 and GSR21-50/80 units, use existing air diaphragm assembly.

⚠ IMPORTANT

After kit is applied, the gas manifold pressure must be checked and properly adjusted as given in the kit's instructions or service and application notes.

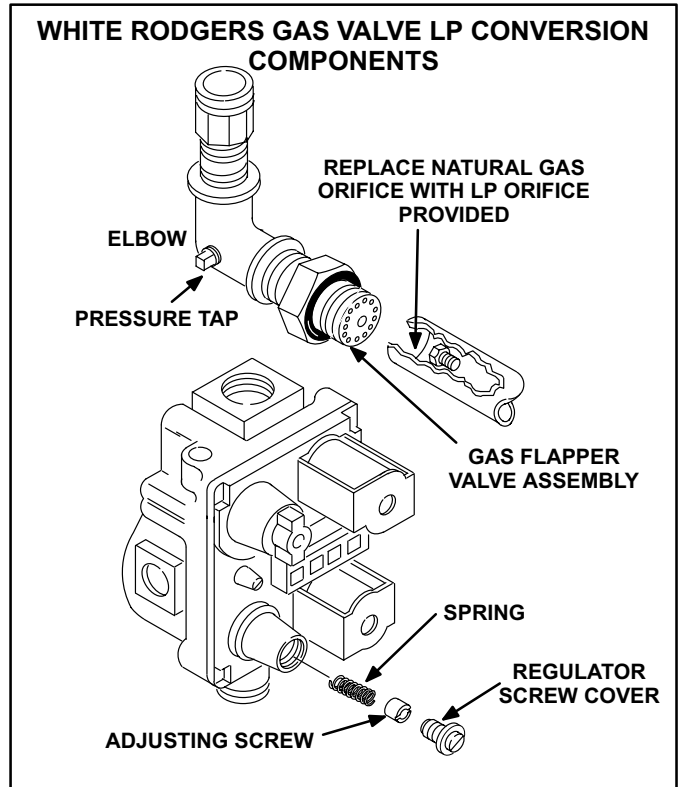

FIGURE 24

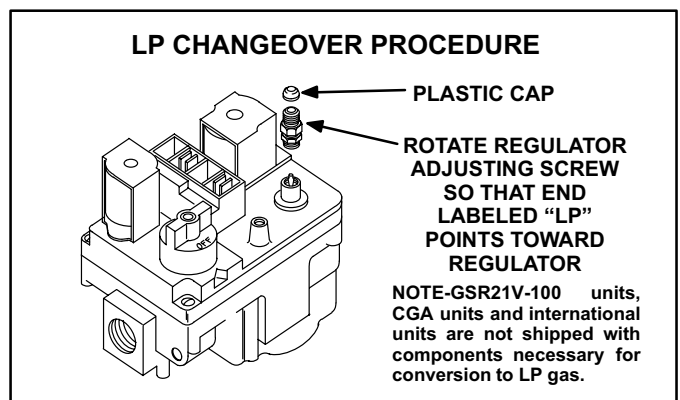

FIGURE 25

H - Differential Pressure Switch (Figure 26)

The differential pressure switch is mounted in the heating compartment [see unit components illustration (page 10) for exact location]. It is connected to the air intake and exhaust outlet by separate lengths of flexible plastic tubing. Note that each flexible hose connects to the barbed fitting at the differential pressure switch. See figure 26. Each fitting has a pop-in orifice of 0.016" I.D.

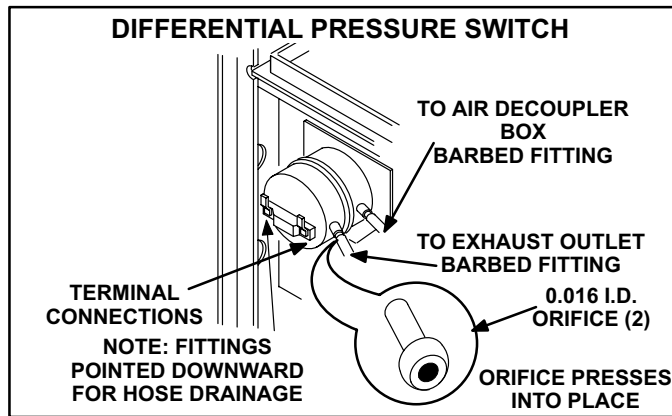

FIGURE 26

! IMPORTANT

Each orifice is critical to switch operation. The orifice reduces extreme positive and negative pressure "peaks" and must be used to prevent erratic switch operation. Do not remove orifice from barbed fitting in pressure switch.

I - Gas Intake Flapper Valve & Orifice (Figure 27)

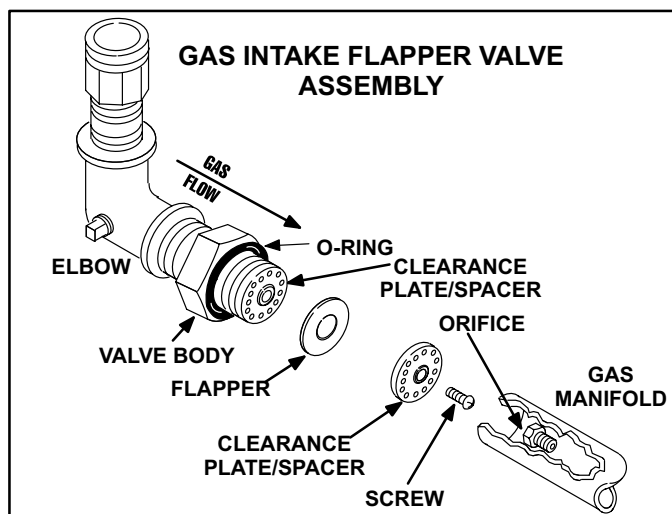

FIGURE 27

1 - Gas Intake Flapper Valve & Assembly

A union at the bottom of the expansion tank provides for removal of gas flapper valve assembly and orifice access.

The flapper moves freely over a spacer and is opened against the clearance plate by incoming gas pressure. Back pressure from each combustion pulse forces the flapper against the valve body closing off gas supply.

Refer to troubleshooting section for specific information about flapper valve inspection and conditions requiring replacement.

! IMPORTANT

Disconnect gas pipe at union. Tighten until bushing seats in orifice housing and gas pipe is in vertical position.

2 - Orifice

! WARNING

Standard atmospheric burner orifices or orifice blanks cannot be used as replacements in G21/GSR21 units.

Each G21/GSR21 unit uses only one orifice located downstream of the flapper valve and sized specifically for each unit. Refer to Service and Application notes for specific orifice size for each unit.

J - Air Intake Chamber & Purge Blower

1 - Air Intake Chamber

An air intake chamber houses the purge blower and air intake flapper valve assembly. Air enters through the air intake pipe (center of mullion), passes through the purge blower and the flapper valve to the combustion chamber. The entire air intake chamber is mounted on a large seal pad to eliminate vibration.

2 - Purge Blower

The purge blower has a 120 volt motor and is permanently lubricated. It is powered during pre- and post-purge and ignition. After the sensor proves flame, the purge blower is de-energized and air is drawn through the blower by negative pressure. During combustion the blower is not powered.

K - Air Intake Flapper Valve

The air intake flapper valve is similar to the gas flapper valve in operation. A flapper moves freely over a spacer between two plates. In actual operation, the flapper is forced against the clearance plate by the purge blower allowing air to enter the combustion chamber. Next, back pressure from combustion forces the flapper against the cover plate closing off the air supply. Finally, as a negative

pressure is created in the combustion chamber, the flapper is drawn to the clearance plate and air enters. Once ignition has occurred, back pressure and negative pressure control the flapper valve with each combustion pulse.

L - Spark Plug & Sensor (Figure 28)

! IMPORTANT
Units with GC-3 ignition controls require a ceramic resistor spark plug.

! IMPORTANT
The spark plug is torqued to 130 ± 5 foot/lbs. The sensor is torqued to 85 ± 5 foot/lbs. Allow metal to cool before measuring torque.

The spark plug is used in conjunction with the primary control for igniting the initial gas and air mixture and is only used during startup.

Figure 28 gives the proper spark gap setting. Note the unusual electrode angle in comparison to other spark plug applications. A feeler gauge can be used to check the gap.

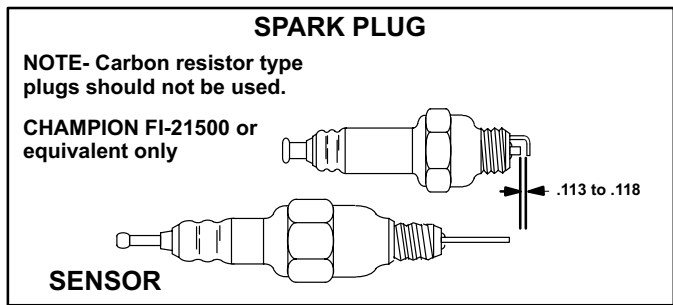

FIGURE 28

Temperatures in the combustion chamber keep the plug free from oxides. It should not need regular maintenance. Compression rings are used to form a seal to the chamber.

The spark plug type sensor has a single electrode (no ground strap). Compression rings are used to form a seal to the chamber. It also should not need regular maintenance. Removal of the plug/sensor is aided by a Lennox spark plug/sensor removal tool. See figure 29. It is available from Lennox Repair Parts, part no. 20H43.

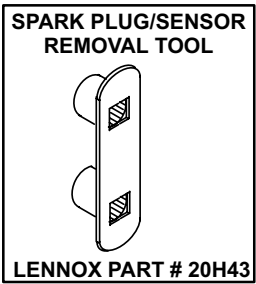

FIGURE 29

The spark plug and sensor are located on the left side of the combustion chamber, see figures 30 and 31 for exact location. The sensor is the top plug and is longer than the spark plug. The spark plug is in the lower position. Plugs cannot be interchanged due to different thread diameters.

M - Combustion Chamber & Heat Exchanger Assembly (Figures 30 and 31)

1 - Combustion Chamber

The combustion chamber has gas and air intake manifolds. See figures 30 and 31 for exact location. Exhaust gas leaves through the tailpipe at the top of the chamber.

2 - Tailpipe

The tailpipe connects the combustion chamber to the exhaust gas decoupler. The tailpipe and decoupler create the proper amount of back pressure for combustion to continue and are major heat exchanger components. The resonator provides attenuation for acoustic frequencies. See figures 30 and 31 for exact location.

3 - Exhaust Decoupler

The exhaust decoupler is manifolded into the condenser coil. Latent heat of combustion is extracted from exhaust gas in the condenser coil. When this is done, condensate (moisture) is produced. The circuiting of the coil allows for proper drainage of condensate to the exhaust outlet line. See figures 30 and 31 for exact location.

4 - Heat Exchanger Assembly

Each unit input size uses a specific heat exchanger assembly. Externally, they may appear the same, but THEY MUST NOT BE INTERCHANGED between unit input sizes. Internal characteristics related to unit input properly match each assembly for unit input rating. See figures 30 and 31 for exact location.

The entire heat exchange assembly is mounted on rubber isolation mounts to eliminate vibration.

! IMPORTANT
If heat exchanger must be replaced, keep orifice from the old heat exchanger. New orifices are not supplied with replacement heat exchangers.

N - Gas & Air Components Applied to Heat Exchanger

Figures 30 and 31 identify all of the components of the basic heating assembly.

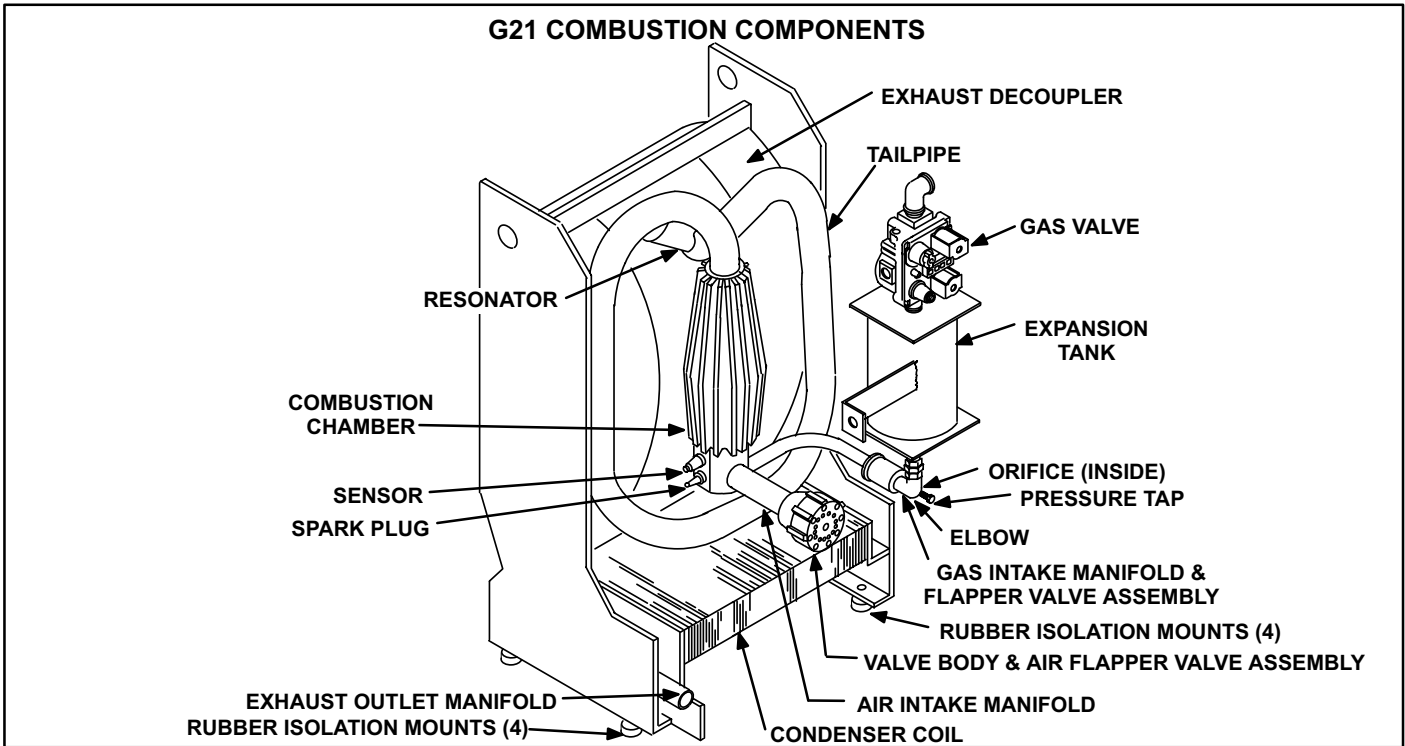

FIGURE 30

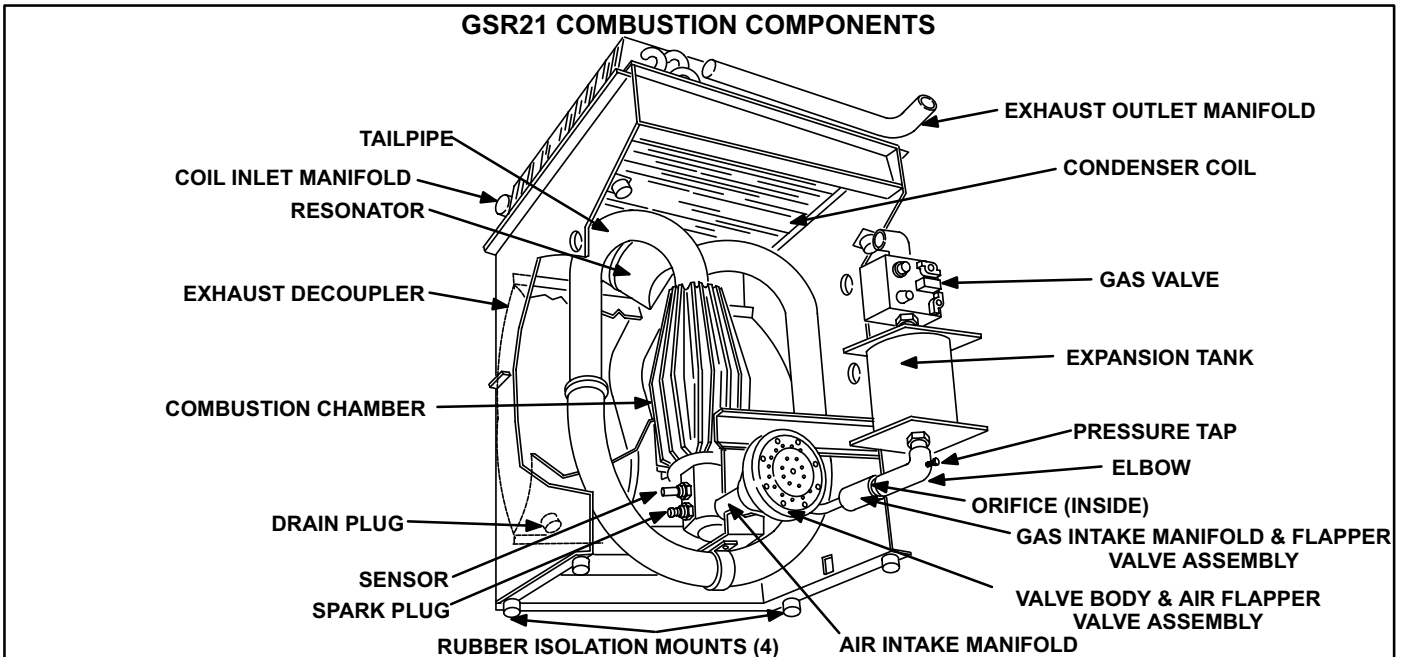

FIGURE 31

Combustion Procedure in G21/GSR21 Units:

- 1- Gas flows through the valve, expansion tank, flapper valve and orifice into the combustion chamber.
- 2- Air flows through the air flapper valve and directly into the combustion chamber. Spark occurs.
- 3- Combustion takes place and exhaust gas flows through the tailpipe, exhaust decoupler and condenser coil to the exhaust outlet.

O - Blower Motors and Capacitors ("Q" Units)

All G21/GSR21 "Q" units use direct drive blower motors. All "Q" motors are 120V permanent split capacitor motors to ensure maximum efficiency. See table 8 for ratings. Multi-speed "Q" blower motors are factory wired for low speed (red tap) heating, GSR21Q3-80 units are wired for medium speed (yellow) tap heating. See table 9.

TABLE 8

G21Q/GSR21Q BLOWER RATINGS 120V 1PH				
BLOWER	MOTOR	HP	CAP	
Q3		1/3	5MFD	370V
Q4		1/2	7.5MFD	370V
Q5		3/4	40MFD	370V

1 - Blower Speed Taps "Q" Units Leadless Motors Only

Some G21/GSR21 "Q" units will be equipped with leadless blower motors. Blower speed tap selection on leadless motors is accomplished by changing taps on the blower motor harness connector. Disconnect harness connector from motor to expose speed selectors. See table 9 for leadless motor blower speed selection.

TABLE 9

BLOWER SPEED SELECTION LEADLESS MOTORS						
UNIT	Factory Connected Speed Taps				Motor Speeds Available	
	Cool		Heat			
Q3-40, Q3-60	2		4		3	
Q3-80			3			
Q3-100			4			
Q4			5			
Q4/5, Q5			6			
BLOWER SPEED SELECTION HI ← → LOW						
SPEED TAPS	2	3	4	4	3	
	2	3	4	5	4	
	2	3	4	5	6	
	2	3	4	5	6	

TABLE 10

BLOWER SPEED CHART						
UNIT	FACTORY CONNECTED SPEED TAP					MOTOR SPEEDS AVAILABLE
	COOL	HEAT	TERMINAL	COVER	TAPS	
Q3-40, 60	BLACK	RED	YELLOW	----	----	3
Q3-80		YELLOW	RED	----	----	3
Q3-100		YELLOW	BROWN	RED	----	4
Q4-60, 80		RED	BROWN	YELLOW	----	4
Q4/5, Q5		RED	BLUE	BROWN	YELLOW	5
BLOWER SPEED SELECTION HI ← → LO						
SPEED TAP	BLACK		YELLOW		RED	3
	BLACK	BROWN	YELLOW	RED	RED	4
	BLACK	BROWN	BLUE	YELLOW	RED	5

To Change Blower Speed "Q" Units With Leadless Motors Only:

- 1 - Turn off electric power to furnace.
- 2 - Lift left side filter over left support angle. For easy handling, hold filter at center bottom.
- 3 - Grasp blower motor harness connector located on back of motor. Depress lock tab and pull connector from motor.
- 4 - Pull harness connector and wires through blower access panel opening.
- 5 - Select desired heating and cooling speeds. (Red = heating, Black = cooling, White = common). See table 9.
- 6 - Depress harness connector tab to release wire terminal. Select connector location for new speed (refer to unit wiring diagram). Insert wire terminal until it is securely in place. See figure 32.
- 7 - Replace harness connector to motor

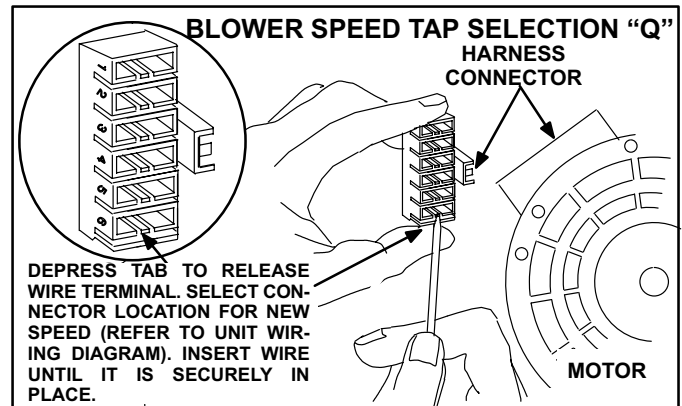

FIGURE 32

2 - Blower Speed Taps "Q" Units leaded Motors Only

G21/GSR21"Q"-9 models will be equipped with leaded motors. Blower speed tap selection on leaded motors is accomplished by changing speed taps. Speed taps are located in the control box. Simply remove control box cover and disconnect current tap, then rewire tap selected. See table 10 for color coded speed taps.

P - ICM1 and ICM2 BLOWER MOTOR (G21V/GSR21V Units)

G21V/GSR21V units use a three-phase, electronically controlled d.c. brushless motor (controller converts single phase a.c. to three phase d.c.), with a permanent-magnet-type rotor (figures 33 and 34). Because this motor has a permanent magnet rotor it does not need brushes like conventional D.C. motors. ICM motors consist of a control module and motor. The ICM control module can be replaced separately from the motor if necessary. However, if the motor fails the motor/module assembly must be replaced. Internal components are shown in figure 35. The stator windings are split into three poles which are electrically connected to the controller. This arrangement allows motor windings to be turned on and off in sequence by the controller.

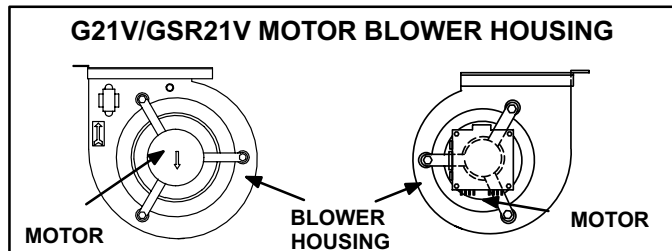

FIGURE 33

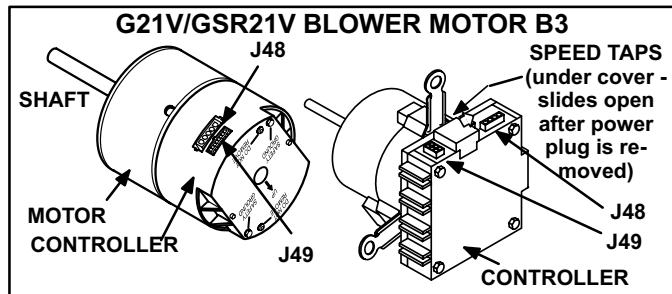

FIGURE 34

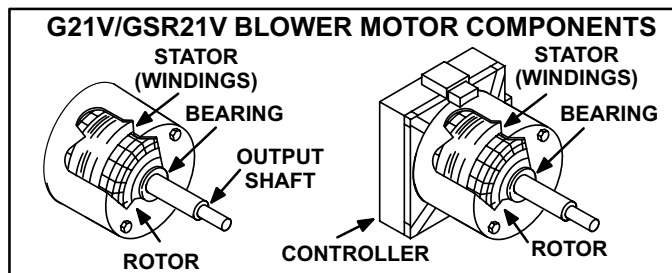

FIGURE 35

The controller is primarily an a.c. to d.c. converter. Converted d.c. power is used to drive the motor. The controller contains a microprocessor which monitors varying conditions inside the motor (such as motor workload).

The controller uses sensing devices to know what position the rotor is in at any given time. By sensing the position of the rotor and then switching the motor windings on and off in sequence, the rotor shaft turns the blower.

G21V/GSR21V series blower motor ratings are listed in table 11. All G21V/GSR21V blower motors use single phase power. An external run capacitor is not used. The motor uses permanently lubricated ball-type bearings.

TABLE 11

ELECTRONICALLY CONTROLLED BLOWER MOTOR CCW ROTATION			
Unit	Volts	Phase	HP
G21V3/GSR21V3	120	1	1/2
G21V5/GSR21V5	120	1	1

Internal Operation

Each time the controller switches a stator winding (figure 35) on and off, it is called a "pulse." The length of time each pulse stays on is called the "pulse width." By varying the pulse width (figure 36), the controller varies motor speed (called "pulse-width modulation"). This allows for precise control of motor speed and allows the motor to compensate for varying load conditions as sensed by the controller. In this case, the controller monitors the static workload on the motor and varies motor rpm in order to maintain constant airflow (cfm).

ICM1 motor is equipped with 11 incremental taps which are driven by the integral controller. The controller is capable of controlling three of the 11 taps.

The VSP2 control gives the ICM2 eight different options for cfm for heat or cool call. Figure 13 shows four pin selections for High/Cool speed and four pin selections for Heat speed. In addition there is four pin selections for Low speed which can be used for either Heat or Cool.

The motor controller is driven by the VSP. The VSP receives its demand (PWM signal or fixed 24 VAC or VDC signal) from optional controls such as the Harmony zone control system, Efficiency Plus Humidity Control (CCB1) or a conventional thermostat.

Motor rpm is continually adjusted internally to maintain constant static pressure against the blower wheel. The controller monitors the static work load on the motor and motor amp-draw to determine the amount of rpm adjustment. Blower rpm may be adjusted any amount in order to maintain a constant cfm as shown in Blower Ratings Tables. The amount of adjustment is determined by the incremental taps which are used and the amount of motor loading sensed internally. Since the blower constantly adjusts rpm to maintain a specified cfm, motor rpm is not rated. Hence, the terms “blower speed” and “speed tap” in this manual, on the unit wiring diagram and on blower B3 refer to blower cfm regardless of motor rpm.

When Harmony is used, speed taps are overridden and a PWM signal generated by the Harmony controller continuously varies motor speed based upon zone demands.

Initial Power Up

When line voltage is applied to B3, there will be a large inrush of power lasting less than 1/4 second. This inrush charges a bank of DC filter capacitors inside the controller. If the disconnect switch is bounced when the disconnect is closed, the disconnect contacts may become welded. Try not to bounce the disconnect switch when applying power to the unit.

The DC filter capacitors inside the controller are connected electrically to the speed tap wires. The capacitors take approximately 5 minutes to discharge when the disconnect is opened. For this reason it is necessary to wait at least 5 minutes after turning off power to the unit before attempting to change speed taps.



⚠ DANGER	
	Disconnect power from unit and wait at least five minutes to allow capacitors to discharge before attempting to adjust motor speed tap settings. Failure to wait may cause personal injury or death.

Motor Start-Up

When B3 begins start-up, the motor gently vibrates back and forth for a moment. This is normal. During this time the electronic controller is determining the exact position of the rotor. Once the motor begins turning, the controller slowly eases the motor up to speed (this is called “soft-start”). The motor may take as long as 10-15 seconds to reach full speed. If the motor does not reach 200rpm within 13 seconds, the motor shuts down. Then the motor will immediately attempt a restart. The shutdown feature provides protection in case of a frozen bearing or blocked blower wheel. The motor may attempt to start eight times. If the motor does not start after the eighth try, the controller locks out. Reset controller by momentarily turning off power to unit.

MOTOR SPEED CONTROL WITH D.C. PULSE-WIDTH MODULATION

Motor speed is determined by the size of the electrical pulse sent to the motor windings. The longer the pulse, the faster the motor.

OUTPUT FROM CONTROLLER TO MOTOR WINDINGS	
WINDINGS TURNED OFF	WINDINGS TURNED ON
	 ON PULSE  OFF PULSE

The frequency of the pulses to the windings is 20KHz.
DO NOT ATTEMPT TO MEASURE THESE VOLTAGES.

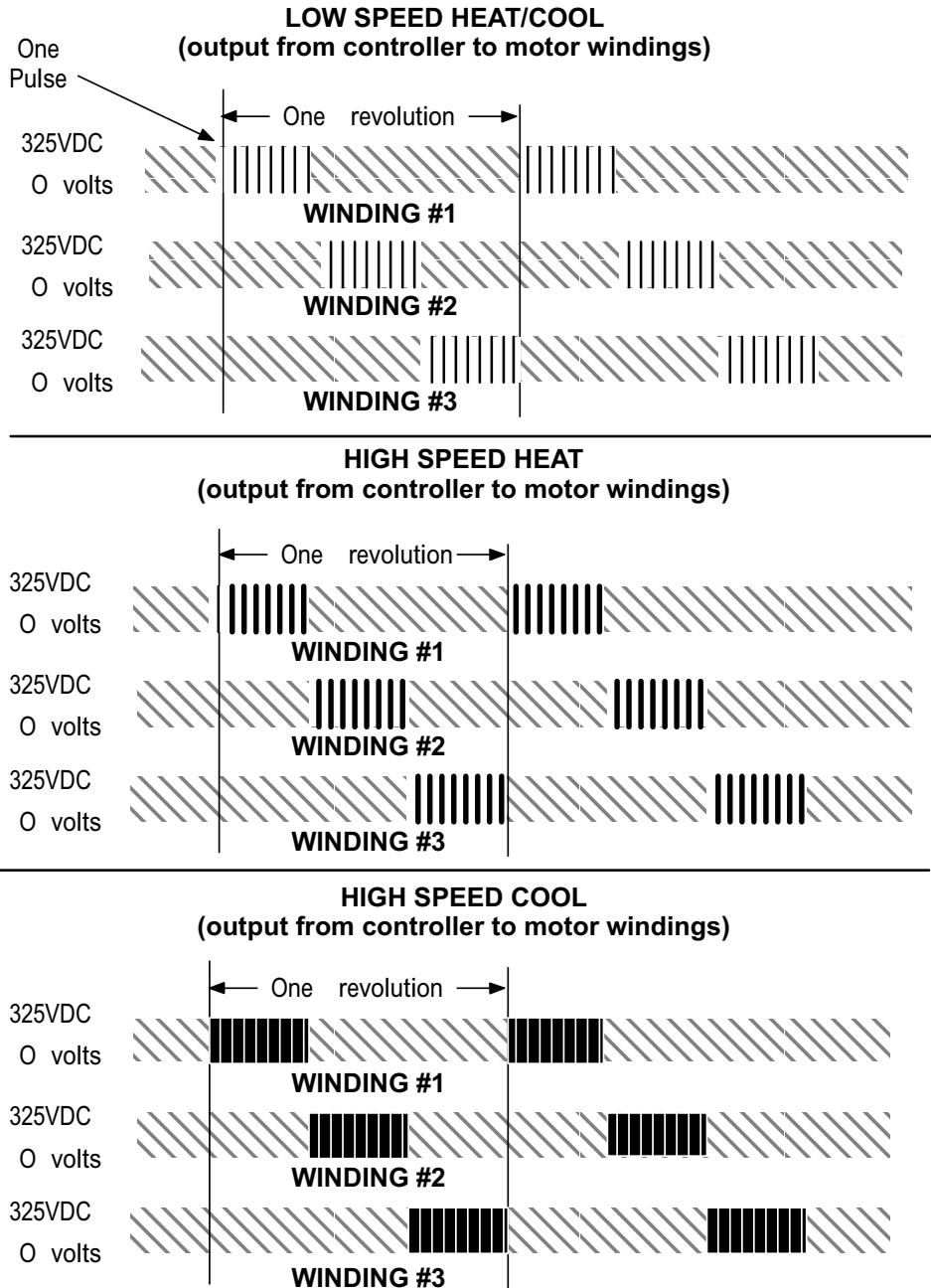

FIGURE 36

1 - External Operation ICM1 (Speed Tap Priority)

Figure 37 shows the two quick-connect jacks (J48 and J49) which connect the motor to the G21V/GSR21V. Jack J48 is the power plug and jack J49 connects the unit controls to the motor. The power plug must be removed to gain access to the incremental (speed) taps.

Line voltage must be applied to J48 pin 1 in order for the motor to operate. When control voltage is applied to J49 pin 1 (low speed cooling), the motor is energized on the low speed heat/cool tap.

When voltage is applied to J49 pin 2 in addition to pin 1 (high speed cooling), the blower is energized on the high speed cooling tap. When voltage is applied to J49 pin 5 (heating demand), the blower is energized on the low speed heat/cool tap. The motor assigns priority to J49 pin 5 so that if a call for cooling and a call for heating are concurrent, heating call overrides and the blower operates on high speed heating tap.

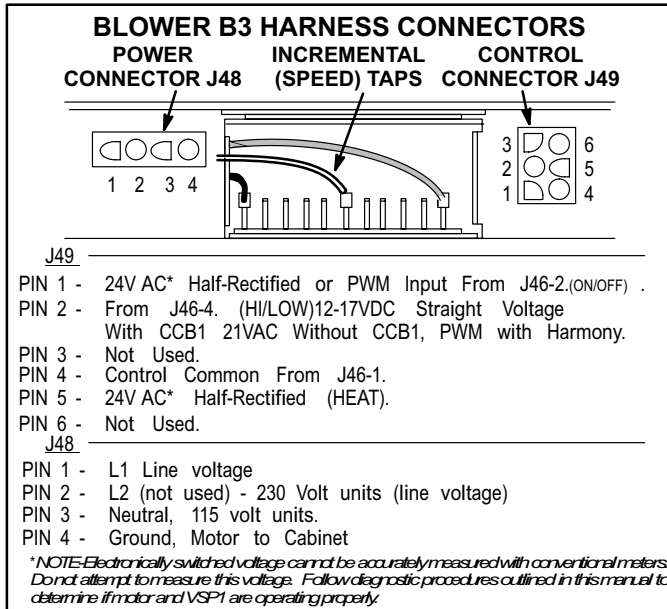

FIGURE 37

a - Blower Speed Taps "V" Units

Table 12 shows the factory set blower speeds. All speeds shown are minimums. Do not change motor taps to operate at speeds lower than the minimum or higher than the maximum. Blower motor and cfm performance ratings are listed in the Blower Data Section.

TABLE 12

FACTORY BLOWER SPEED TAP SELECTION			
MODEL NUMBER	LOW SPEED HEAT/COOL	HIGH SPEED COOLING	HIGH SPEED HEATING
G21V3-60	2	11	6
G21V3-80	2	11	7
GSR21V3-80	3	11	7
G21/GSR21V5-80	2	11	6
G21/GSR21V5-100	2	11	7

⚠ DANGER



Disconnect power from unit and wait at least five minutes to allow capacitors to discharge before attempting to adjust motor speed tap settings. Failure to wait may cause personal injury or death.

Use the following procedure to change blower speed selection for high, low or heat speed selection:

- 1- Disconnect line voltage from unit.
- 2- Wait 5 minutes.
- 3- Disconnect AC power plug P48 from motor/controller. See figure 37.
- 4- Slide tap cover toward AC power plug. See figure 38.
- 5- Remove the appropriate speed connector and place it on the proper tap. See figure 39.
- 6- When all connections are made to proper taps, close tap cover and reconnect AC power plug to motor/controller and reconnect line voltage to unit.

If any of the tap wires are left disconnected, the motor reverts to default speed taps. If the black or red wires are left off, the motor defaults to tap 11. If the white wire is left off, the motor defaults to tap 5.

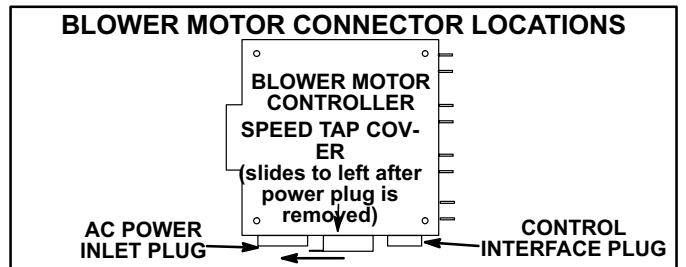

FIGURE 38

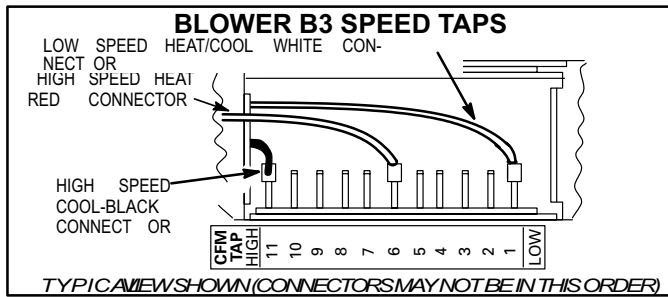

FIGURE 39

⚠ DANGER

Do not attempt to repair electronically controlled blower motor or VSP1. There are no field serviceable parts. If either component appears to be faulty after following checkout procedure, replace entire component then recheck for proper operation.

b - Heating Mode (Three Modes)

1- Single-Stage Heating

The “HB” and “W2” terminals are jumpered together. DS1 (ON/OFF) and DS2 (HEAT) LEDs are lit to indicate the blower is operating in heating speed (high speed heat tap). These LEDs are lit after 75 seconds (30 seconds pre-purge and 45 seconds fan-on time) from the time a call for heat is made.

2- Two-Stage Heating

The DS1 LED is lit to indicate blower operation in first stage heat (low speed heat/cool tap). It is energized 75 seconds (30 seconds pre-purge and 45 seconds time “ON” delay) after “W1” terminal is energized from thermostat terminal “W1.”

DS1 and DS2 LEDs are lit to indicate blower operation in second stage heat (high speed heat tap). Second stage heat signal is applied to “W2” from “W2” terminal of thermostat.

3- Harmony Heating

Blower speed is controlled by the PWM (pulse width modulation) signal sent from the master control of the Harmony zoning system to the terminal strip’s “DS” terminal. DS1 and DS3 LEDs are lit to indicate the blower is operating. Harmony overrides blower speed taps. Blower speed varies according to zone demand.

c - Cooling Mode (Five Modes)

1 - Non-Zoned Units With Single-Speed Compressor Without CCB1

Terminals “DS” and “G” must be jumpered together. This forces the blower to run on the high speed cool tap. DS1 and DS3 LEDs are lit to indicate blower operation on the high speed cooling tap.

2 - Non-Zoned Units With Two-Speed Compressor Without CCB1

⚠ IMPORTANT

“Y2” must be jumpered to “DS” in two-speed, non-zoned applications when CCB1 is not used.

The ON/OFF LED DS1 is lit to indicate the blower is operating on the low speed heat/cool tap. DS1 is energized when a 24VAC thermostat demand is supplied to the control (terminal “G” on the control box terminal strip). The ON/OFF LED (DS1) and speed regulation LED (DS3) are lit to indicate blower is operating on high speed cooling tap (24VAC is supplied to the unit terminal strip “Y2” from “Y2” on the thermostat). Jumper terminals DS and Y2 together when CCB1 is not used.

3 - Non-Zoned Single Speed and Two-Speed Units With CCB1

Terminal DS connects to the DS output from the CCB1. The blower speed is controlled by the DC signal from the CCB1. The ON/OFF LED (DS1) is lit to indicate the blower is operating on the low speed heat/cool tap. The ON/OFF LED (DS1) and the speed regulation LED (DS3) are lit to indicate the blower is operating on the high speed cooling tap.

⚠ IMPORTANT

Never jumper “Y2” to “DS” when CCB1 is used. Damage to the CCB1 control will occur.

4 - Zoned Units with Single-Speed Compressor

Blower speed is controlled by a PWM (pulse width modulation) signal sent from the master control of the zoning system to the terminal strip’s “DS” terminal. DS1 and DS3 LEDs are lit to indicate blower operation. Harmony overrides blower speed taps. Blower speed varies according to zone demand.

5 - Zoned Units with Two-Speed Compressor

Blower speed is controlled by the PWM (pulse width modulation) signal sent from the master control of the zoning system to the terminal strip’s “DS” terminal. DS1 and DS3 LEDs are lit to indicate the blower is operating. Harmony overrides blower speed taps. Blower speed varies according to zone demand.

**TABLE 13
VSP2-1 OPERATION**

HEATING MODE		COOLING MODE	
UNITS WITH SINGLE-STAGE HEATING	UNITS WITH TWO-STAGE HEATING	UNITS WITH SINGLE-SPEED COMPRESSOR	UNITS WITH TWO-SPEED COMPRESSOR
<p align="center">NON-ZONED APPLICATIONS</p> <p>With the HTG. BLOWER jumper in position #1, the ON/OFF LED-DS3 and HEAT LED-DS2 are lit to indicate the blower is operating in heating speed.</p> <p>These LEDs are lit after 75 seconds (30 seconds pre-purge and 45 seconds fan "ON" time) from the time a call for heat is made. For low speed operation with single stage heating, place HTG. BLOWER jumper in position #2.</p> <p>This will run the blower on low speed when "W1" is energized. (ON/OFF LED-DS3 will be the only light on.)</p>	<p align="center">NON-ZONED APPLICATIONS</p> <p>With the HTG. BLOWER jumper in position #2, the ON/OFF LED-DS3 is lit to indicate the blower is operating in low speed.</p> <p>This LED is lit after 75 seconds (30 seconds pre-purge and 45 seconds time fan "ON" delay) from the time the "W1" terminal is energized from "W1" from the thermostat. The ON/OFF LED-DS3 and HEAT LED-DS2 are lit to indicate that the blower is in heating speed.</p> <p>The second stage heat signal is applied to "W2" from "W2" terminal of the thermostat.</p>	<p align="center">NON-ZONED APPLICATIONS</p> <p>The terminals "DS" and "G" must be jumpered together. HI/LOW LED-DS1 and ON/OFF LED-DS3 are lit to indicate the blower is operating.</p>	<p align="center">NON-ZONED APPLICATIONS</p> <p>The ON/OFF LED-DS3 is lit to indicate the blower is operating in first stage cooling. This LED is energized on when a 24VAC thermostat demand is supplied to the control (terminal "G" on the control box terminal strip).</p> <p>In second stage, the ON/OFF LED-DS3 and HI/LOW LED-DS1 are lit to indicate the blower is operating on high speed (24VAC is supplied to the unit terminal strip "Y2" from "Y2" on the thermostat).</p> <p><i>NOTE—"Y2" must be jumpered to "DS" in two-speed, non-zoned applications</i></p>
<p align="center">ZONED APPLICATIONS</p> <p>The blower speed is controlled by the PWM (pulse width modulation) signal sent from the control center of the zoning system to the terminal strip's "DS" terminal. HI/LOW LED-DS1 and ON/OFF LED-DS3 are lit to indicate the blower is operating.</p> <p><i>NOTE—In Harmony II zoning applications, HTG. BLOWER jumper must be in position #2.</i></p>	<p align="center">ZONED APPLICATIONS</p> <p>The blower speed is controlled by the PWM (pulse width modulation) signal sent from the control center of the zoning system to the terminal strip's "DS" terminal. HI/LOW LED-DS1 and ON/OFF LED-DS3 are lit to indicate the blower is operating.</p> <p><i>NOTE—In Harmony II zoning applications, HTG. BLOWER jumper must be in position #2.</i></p>	<p align="center">ZONED APPLICATIONS</p> <p>The blower speed is controlled by the PWM (pulse width modulation) signal sent from the control center of the zoning system to the terminal strip's "DS" terminal. HI/LOW LED-DS1 and ON/OFF LED-DS3 are lit to indicate the blower is operating.</p>	<p align="center">ZONED APPLICATIONS</p> <p>The blower speed is controlled by the PWM (pulse width modulation) signal sent from the control center of the zoning system to the terminal strip's "DS" terminal. HI/LOW LED-DS1 and ON/OFF LED-DS3 are lit to indicate the blower is operating.</p>

III - PROPER INSTALLATION

Refer to the G21/GSR21 series units Installation-Operation-Maintenance Instruction Manual for complete installation instructions. Also see figures 42, 43 and 44.

On units equipped with a GC-1 ignition control, on initial power-up of the ignition control, it is possible to get a spark from the spark plug without any heating demand from the thermostat. This is an inherent property of ignition controls used in all furnaces. A spark could ignite any PVC glue fumes accumulated in the combustion chamber and could result in drain tap or intake line damage.

A - Proper Grounding

G21/GSR21 units are equipped with a grounding lug located in the control box. Connection to earth ground is made here.

B - Isolation Mount Pads (Isomode)

If leveling bolts are not used, vibration isolating pads should be used especially when installed on wood flooring. Isomode pads or equivalent should be used.

C - Flexible Boot(Supply/Return Air Plenum)

A flexible canvas boot or equivalent should be used in the supply air plenum, above the cooling coil or future coil location. For

the return air plenum a flexible canvas boot or equivalent should be used and located as close to the furnace as possible. It is preferred to locate the boot between the furnace and the external electronic air cleaner, if used.

D - Supply Air Plenum or Return Air Plenum Insulation Past First Elbow

A 1.5 to 3 lb. density, matte face, 1 inch thick insulation should be used and all exposed edges should be protected from air flow.

E - Transporting the Unit

When moving or lifting the unit all access panels must be in place to prevent damage (sagging) to the unit. The blower may be removed to reduce the unit weight while moving.

F - Electrical Conduit Isolated from Duct System and Joists

The electrical conduit can transmit vibration from the cabinet to the duct system or joists if clamped to either one. It may be clamped tightly to the unit cabinet but should not touch ductwork or joists.

TYPICAL GSR21 HORIZONTAL INSTALLATION*

When viewing unit from front, circulating air blower compartment must be relocated to the right.

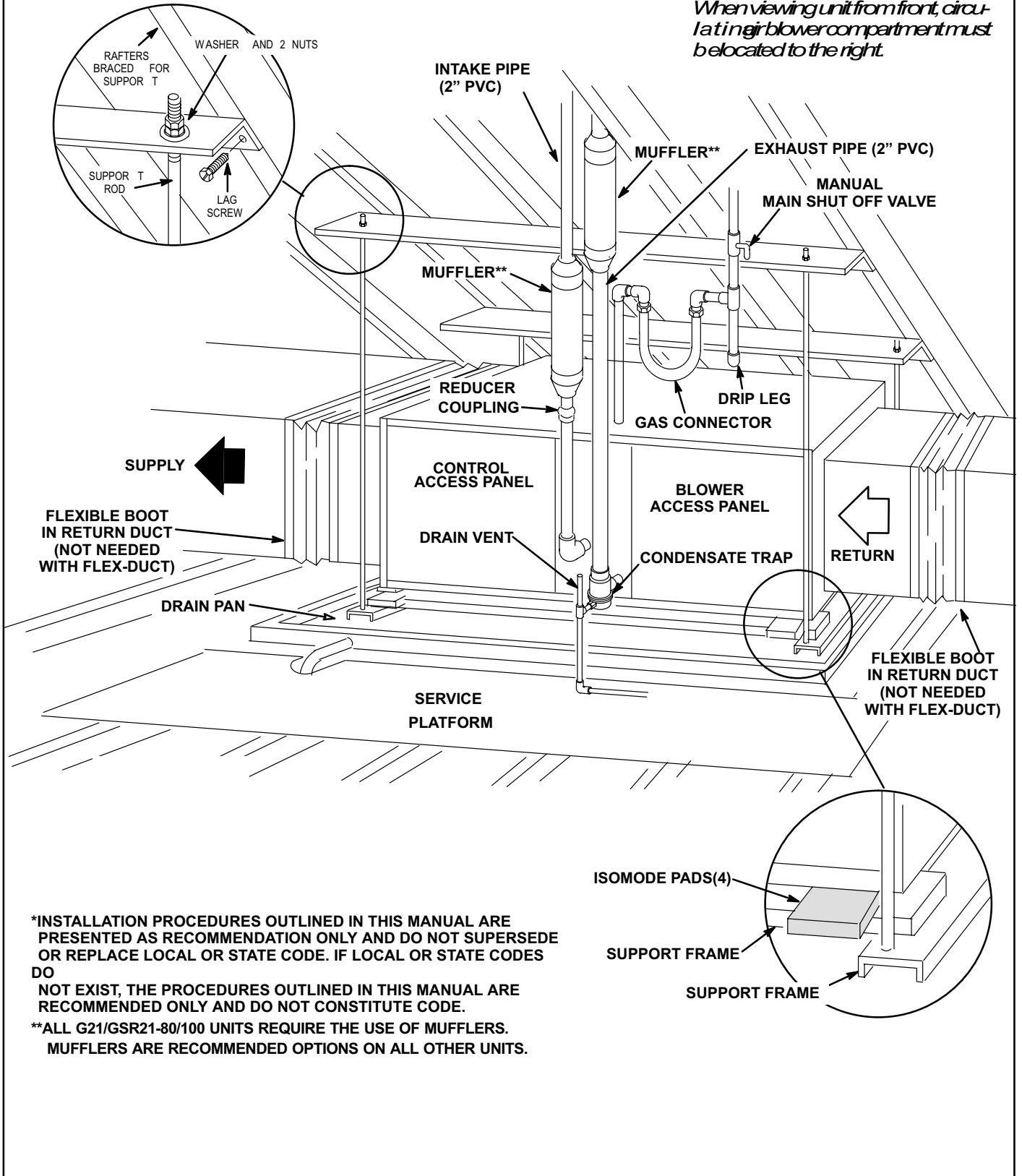
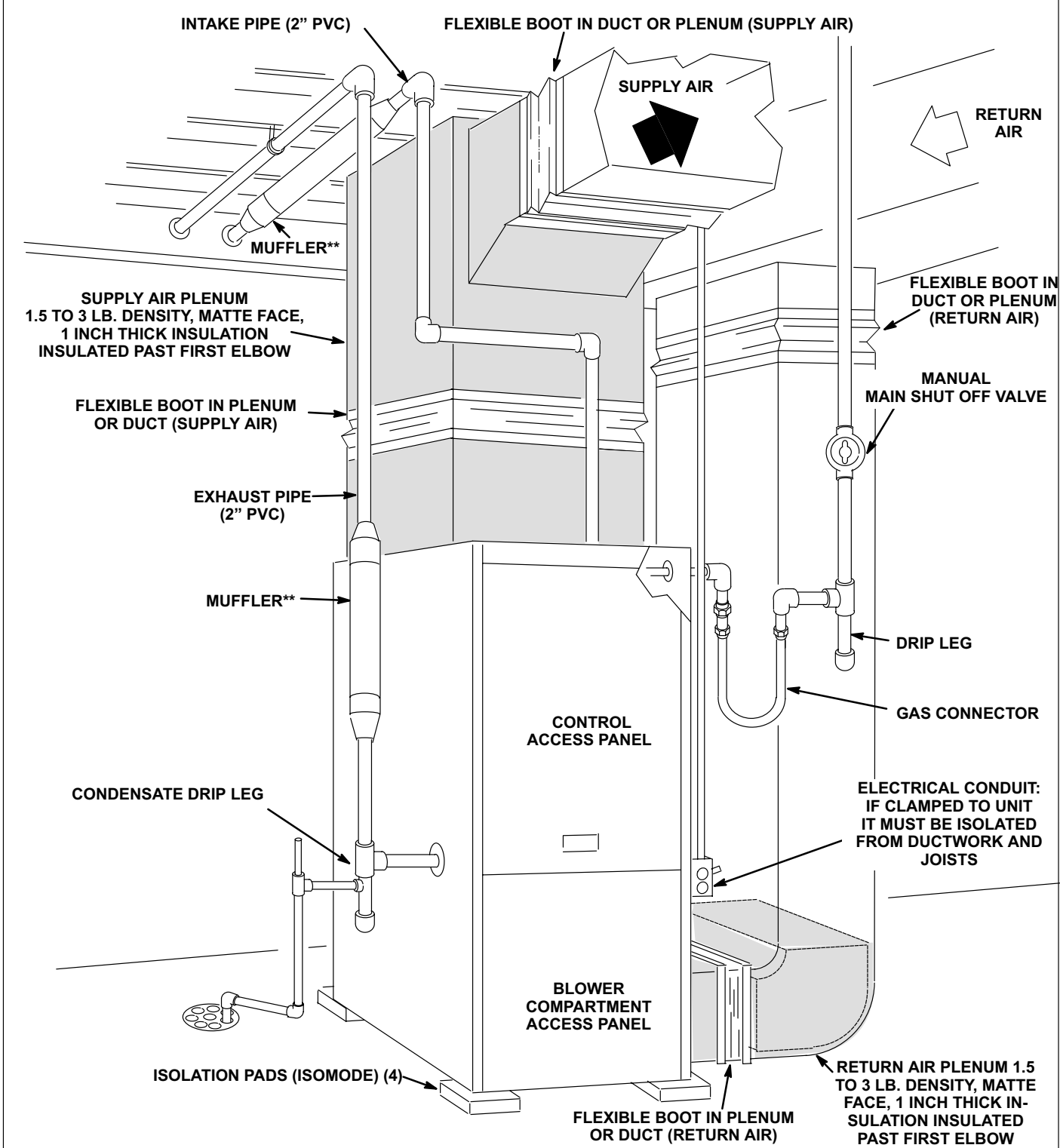

FIGURE 42

TYPICAL G21 INSTALLATION*



*INSTALLATION PROCEDURES OUTLINED IN THIS MANUAL ARE PRESENTED AS RECOMMENDATION ONLY AND DO NOT SUPERSEDE OR REPLACE LOCAL OR STATE CODE. IF LOCAL OR STATE CODES DO NOT EXIST, THE PROCEDURES OUTLINED IN THIS MANUAL ARE RECOMMENDED ONLY AND DO NOT CONSTITUTE CODE.
 **ALL G21/GSR21-80/100 UNITS REQUIRE THE USE OF MUFFLERS. MUFFLERS ARE RECOMMENDED OPTIONS ON ALL OTHER UNITS.

FIGURE 43

TYPICAL GSR21 DOWNFLOW INSTALLATION*

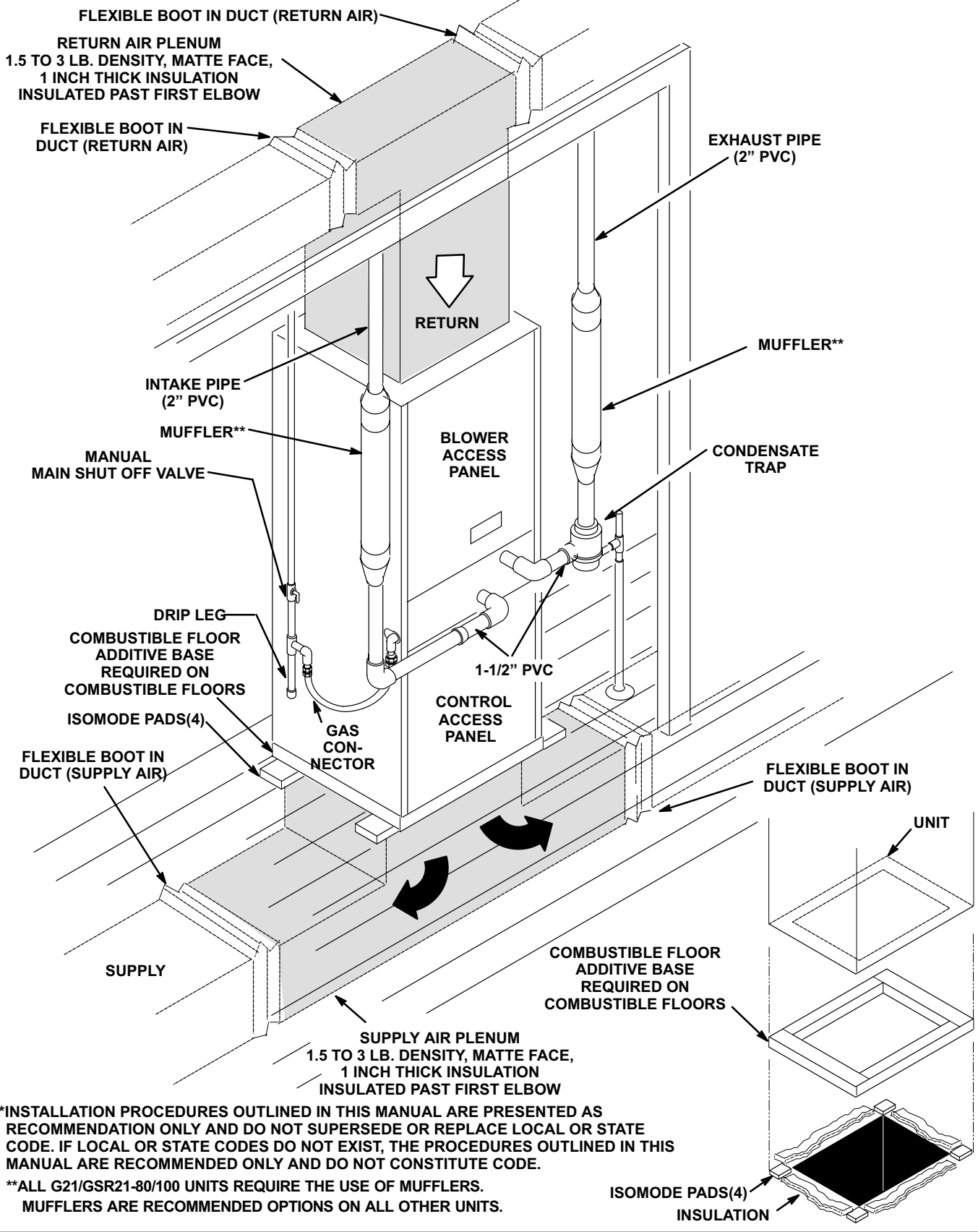

FIGURE 44

G - Condensate Line (Figure 45)

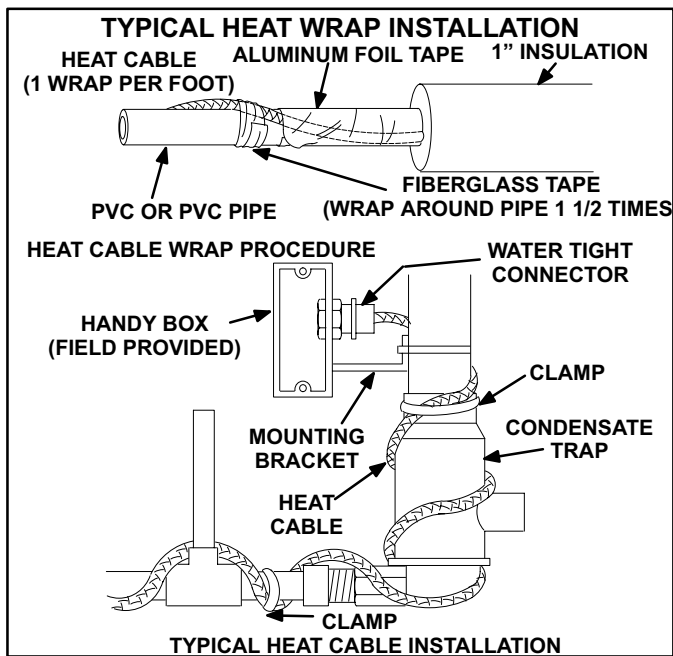

FIGURE 45

When installing the unit in areas subjected to freezing temperature, the condensate trap and condensate line must be wrapped with electrical heat cable to prevent the condensate from freezing. A heat cable kit, which is approved for use with PVC pipe is available from Lennox Repair Parts. Refer to G21/GSR21 heat cable kit installation instructions for proper application.

H - Gas Supply Piping Centered In Inlet Hole (Figure 46)

The gas supply pipe should not rest on the unit cabinet. See figure 46. The gas supply connector should be hung as shown in figure 47.

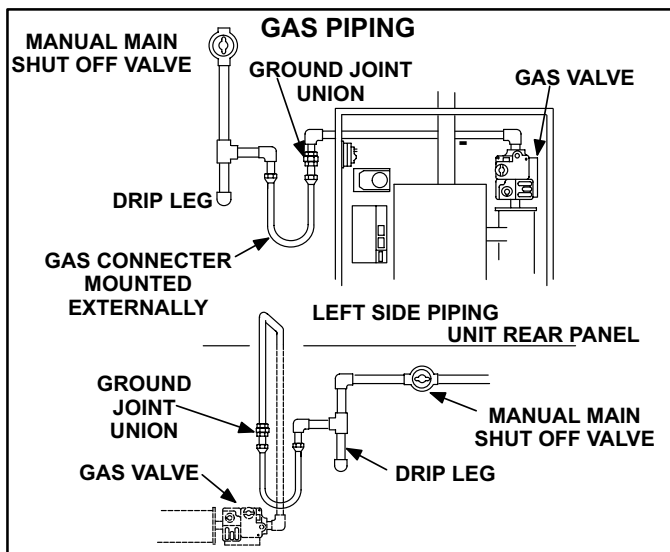

FIGURE 46

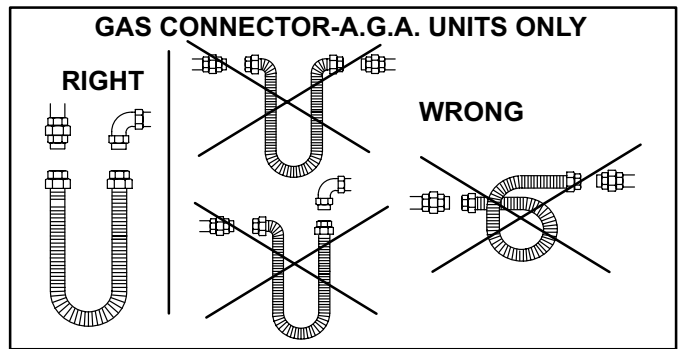

FIGURE 47

WARNING

The flexible gas connector (if used) must be mounted external to the unit. The connector must hang freely and must not contact or rub outside objects. The flexible connector must not enter the unit. See figure 46.

I - Muffler

All G21/GSR21-80/100 units require the use of mufflers. Mufflers are optional on all other units and recommended.

IMPORTANT

Any time an exhaust muffler is used in areas subjected to freezing temperature, a heat cable kit must be used on the muffler to prevent condensate from freezing.

Use only Lennox heat cable kits which are approved for use with PVC pipe.

J - Exhaust Insulation

In areas subject to freezing temperature, exhaust pipe must be insulated with 1/2" Armaflex or equivalent when run through unconditioned space. In extreme cold climate areas, 3/4" Armaflex insulation is recommended.

K - Isolation Hangers (Figure 48)

PVC piping for intake and exhaust lines should be suspended (supported) from hangers every five feet. A suitable hanger can be fabricated from a 1" wide strip of 26 ga. metal covered with "Armaflex" or equivalent. See figure 48.

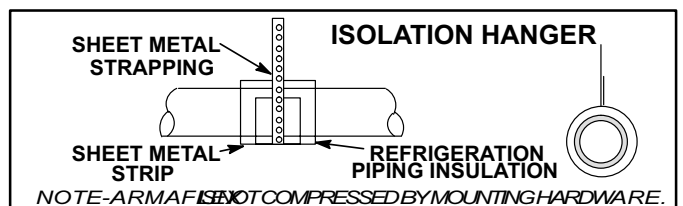

FIGURE 48



FIGURE 49

L - Horizontal Mounting (Figure 49)

When mounting unit horizontally it must be placed so that when facing the unit the airflow is from right to left. This placement is necessary so moisture can drain from the condensing coil. This must not be changed. If installed in any other position, such as inverted or on its back, the condensing coil will fill with condensate and make the unit inoperable. See figure 49.

M - Support Frame and Suspension Rods (Figure 49)

A support frame must be used to prevent damage anytime a unit is to be suspended. A support frame kit is available from Lennox.

N - Raised Platform

When installed in a crawlspace or on attic beams it is important that the unit be supported by a flat base to prevent damage (sagging) to unit.

O - Combustible Floor Additive Base

A combustible floor additive base (figure) must be used when the unit is installed on a combustible floor (downflow installations). It is available from Lennox Repair Parts.

P - Drain Pan

A drain pan should be used in all applications where surrounding structures, such as walls or ceilings, might be damaged by potential condensate leakage. If an evaporator coil is used, the drain pan should be extended under the coil to catch potential condensate leakage.

In any installation where the unit is mounted horizontally a drain pan can be used to catch potential condensate leakage.

Q - Drip Leg Assembly (G21 only) (Figures 50 and 51)

A drip leg must be used to remove condensate and exhaust from the unit. A drip leg assembly may be used on the G21 only. If unit condensate line is clogged or obstructed, excess water may shut down the unit. G21 drip leg assemblies may contain a threaded pipe plug or a removable rubber boot with clamp, for cleanout of debris in drip leg.

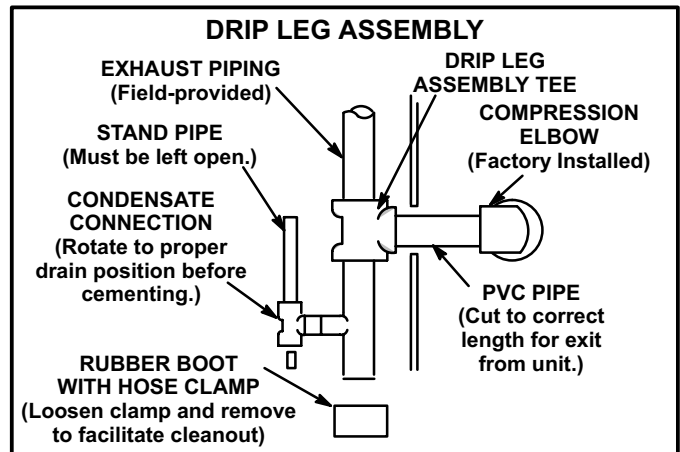

FIGURE 50

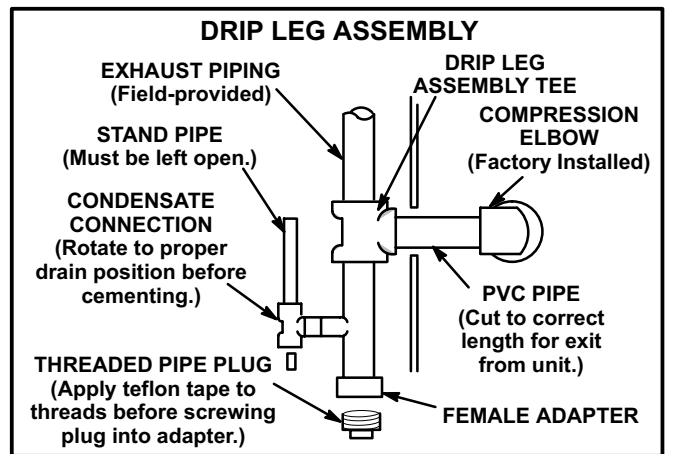

FIGURE 51

R - Ball Float Condensate Trap Assembly (G21/GSR21) Figures 52, 53 and 54

A ball float condensate trap must be used on GSR21 and may be used on G21 units. It was designed to save room in GSR21 horizontal installations. The float trap serves a dual purpose. It is a means of removing condensate and exhaust from the unit.

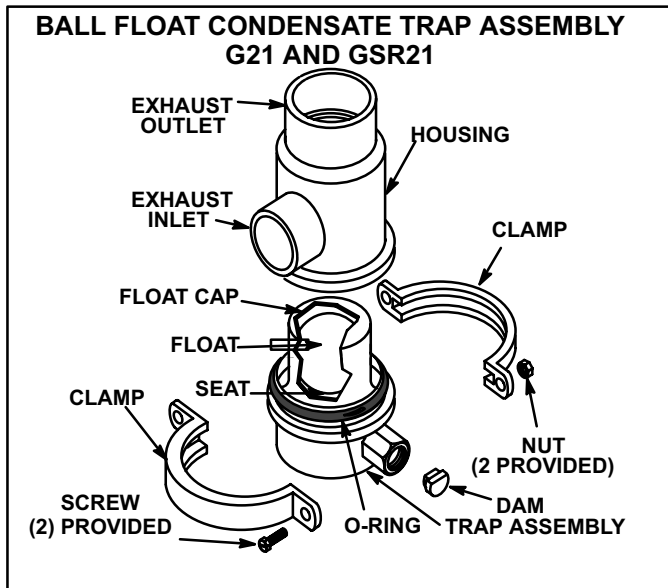

FIGURE 52

When installing a ball float trap, certain precautions should be taken. Condensate trap housing must be cemented to the outlet exhaust pipe perpendicular with the bottom of unit to ensure proper operation of trap float. Complete installation procedures are outlined in GSR21 installation and operation instructions.

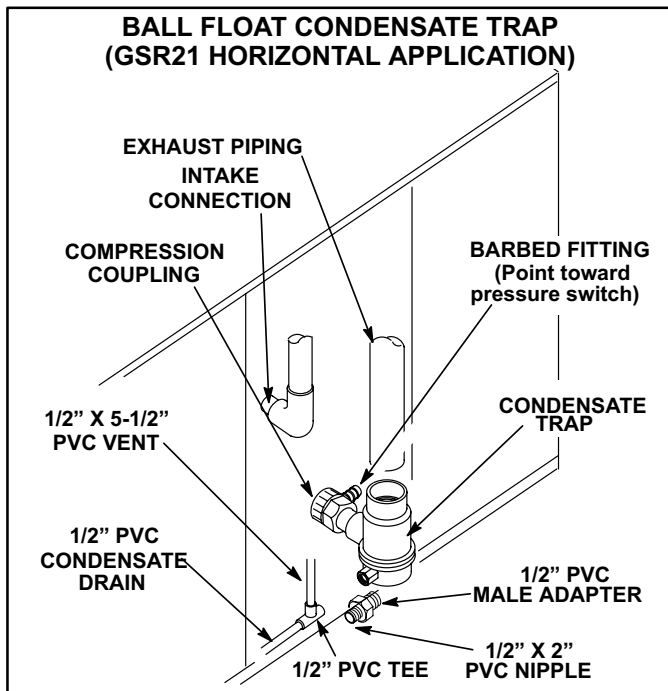

FIGURE 53

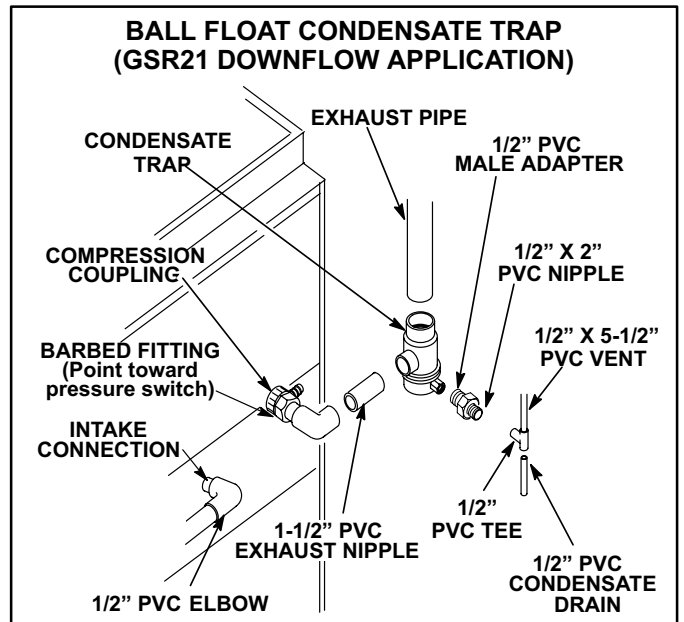

FIGURE 54

Service Procedures for Ball Float Condensate Trap

- 1- Remove screws and clamps from condensate trap assembly .
- 2- Lower trap assembly from housing. Care should be taken not to crack seal from housing to exhaust pipe and compression coupling.
- 3- Disconnect trap assembly from condensate line.
- 4- Remove float cap, float, seat, and o-ring and visually inspect for cuts or breakdown of material. If seat, float or o-ring are worn, a G21/GSR21 Condensate Trap Parts Replacement Kit is available from Lennox Repair Parts.
- 5- Use a 1/4" hex wrench, remove plastic dam located in condensate line connection of trap assembly. Check interior of trap assembly for debris.
- 6- Clean trap assembly with a mild soap and rinse thoroughly .
- 7- Carefully reinstall dam, seat, float, float cap, and o-ring to trap assembly. If float cap does not snap closed, the entire trap assembly must be replaced.
- 8- Connect trap assembly to condensate line.
- 9- Lubricate o-ring with water or silicone based lubricant and reinstall trap assembly to housing. Using existing clamps and screws, secure trap assembly to housing.

⚠ WARNING

After reassemble, double check all connections to prevent exhaust products from entering living space.

S - Concentric Termination (Figures 55, 56 and 57)

In concentric termination, intake and exhaust piping are centrally located. See figures 55 and 56. See figure 57 for a detailed cutaway.

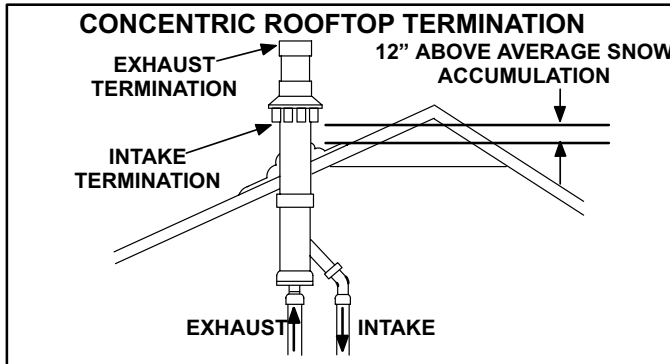

FIGURE 55

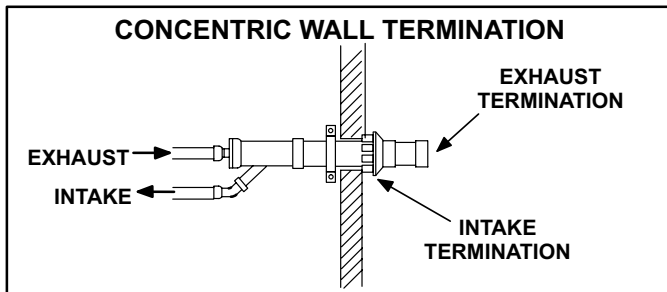

FIGURE 56

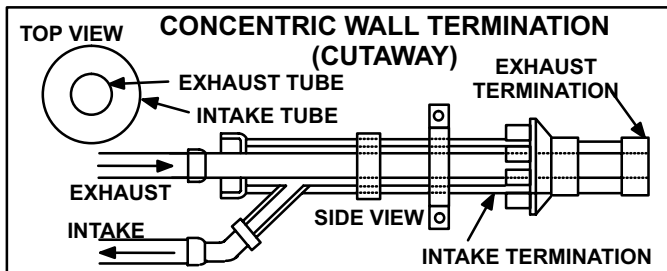

FIGURE 57

Exhaust piping must terminate straight out or up at a level 12 inches above normal snow accumulation. Termination must not be within six feet of other vents or three feet of structure openings. For proper vent sizes see table 14 .

TABLE 14

MINIMUM DIAMETER FOR G21/GSR21 VENTING					
Pipe Length (Max. Feet)	Number of 90° Elbows				
	0	2	4	6	8
5	2	2	2	2	2
10	2	2	2	2	2
20	2	2	2	2	2-1/2
30	2	2	2	2-1/2	2-1/2
40	2	2	2-1/2	2-1/2	2-1/2
50	2	2-1/2	2-1/2	2-1/2	2-1/2
60	2-1/2	2-1/2	2-1/2	2-1/2	3
70	2-1/2	2-1/2	2-1/2	3	3
80	2-1/2	2-1/2	3	3	3
90	2-1/2	3	3	3	3

Refer to GSR21/GSR14 Exhaust/Intake Air Termination Kits installation instructions for installation procedures which meet local and national codes.

⚠ IMPORTANT

The exhaust line must be reduced at wall termination to 1-1/2".

T - Standard Intake/Exhaust Termination (Figures 58, 59, 60, 61)

Intake and exhaust pipes should be placed as close together as possible at termination end. MAXIMUM SEPARATION IS 3 IN. ON ROOF TERMINATION AND 6 IN. ON SIDE WALL TERMINATIONS. END OF EXHAUST PIPE MUST EXTEND AT LEAST 8 IN. PAST END OF INTAKE PIPE.

Intake MUST be up-wind (prevailing wind) of exhaust pipe. Both intake and exhaust MUST be in the same pressure zone (do not exit one through the roof and one through the side of the house). These precautions are to ensure that no exhaust gas recirculation occurs.

Exhaust piping must terminate straight out or up and termination must not be within six feet of other vents or three feet of structure openings. For proper sizing see table 14.

Refer to G21/GSR21 operation and installation instructions for detailed instruction of proper termination installations which meet local and national codes.

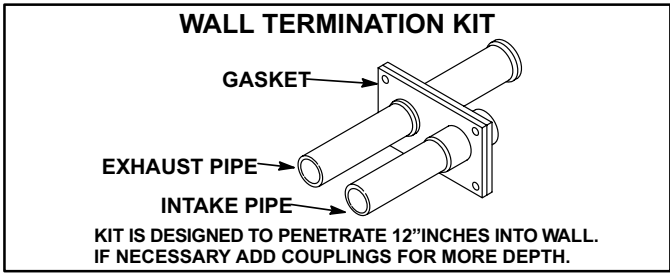

FIGURE 58

⚠ WARNING

Solvent cements for plastic pipe are flammable liquids and should be kept away from all sources of ignition. Good ventilation should be maintained to reduce fire hazard and to minimize breathing of solvent vapors. Avoid contact with skin and eyes.

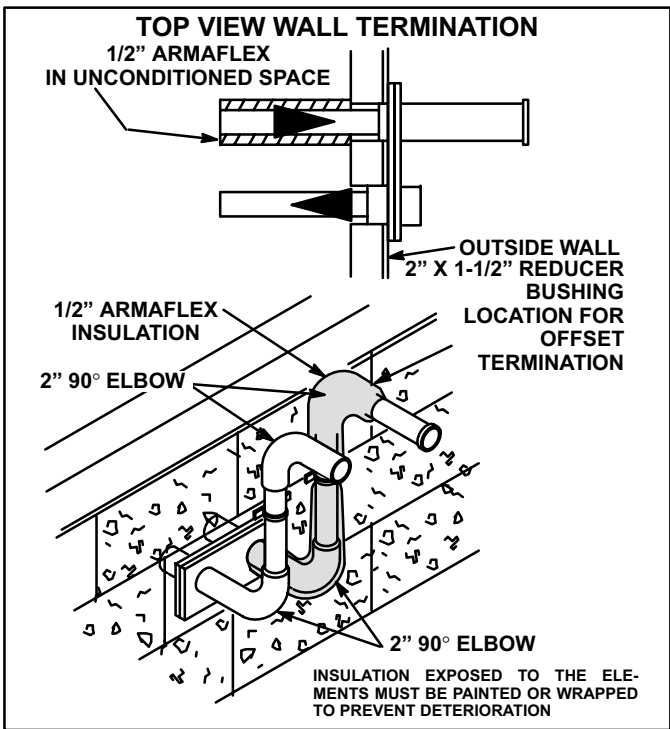

FIGURE 59

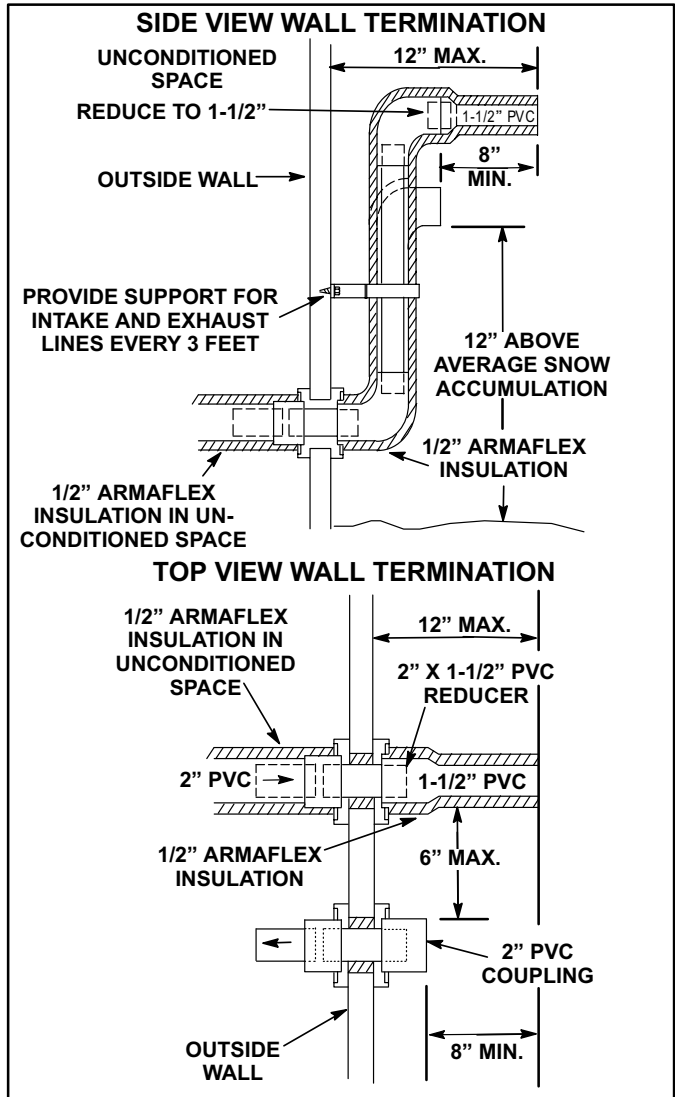

FIGURE 60

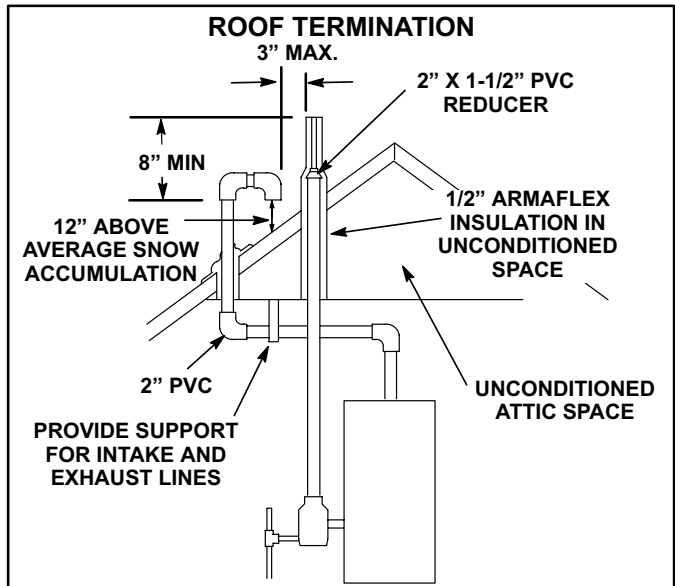

FIGURE 61

IV - SEASONAL MAINTENANCE

At the beginning of each heating season, the system should be checked as follows:

A - Supply Air Blower

- 1 - Check and clean blower wheel
- 2 - Motor Lubrication- Always lubricate the blower motor according to the manufacturer's lubrication instructions on each motor. If no instructions are provided, use the following as a guide:
 - a - Motors without oiling ports - Pre-lubricated and sealed no further lubrication needed.
 - b - Direct drive motors with oiling ports - Pre-lubricated for an extended period of operation and **do not** require additional oil for normal use.

B - Filters

- 1 - Filters must be cleaned or replaced when dirty to assure proper unit operation. Clean as necessary.
- 2 - The filters supplied with the G21/GSR21 can be washed with water and mild detergent. When dry, they should be sprayed with Filter Handicoater before reinstalling in the unit. Filter Handicoater is RP Products coating no. 418 and is available from Lennox Repair Parts (No. P-8-5069).

C - Fan Controls & Limit Controls

Check fan and limit controls for proper operation and setting. For settings, refer to the sections on the VSP2 Blower Control Board, Fan Timing Control A28 and Limit Control/Modulation Limit Control in this manual.

D - Purge Blower

Periodically inspect and clean purge blower wheel.

- 1 - Disconnect power to the unit.
- 2 - Remove upper heating compartment access panel.
- 3 - Remove air decoupler box cover
- 4 - Remove wires that power purge blower
- 5 - Remove screws holding purge blower housing together.
- 6 - Check and clean blower wheel.
- 7 - Reassemble in reverse order

E - Intake/Exhaust Lines

Check intake and exhaust PVC lines and all connections for tightness and make sure there are no leaks or blockage. Also check condensate line for free flowing operation and complete drainage.

F - ELECTRICAL

- 1 - Check all wiring for loose connections.
- 2 - Check for correct voltage.
- 3 - Select fuse and wire size according to blower motor amps.
- 4 - Access openings are provided on both sides of cabinet to facilitate wiring.
- 5 - Install room thermostat according to instructions provided with thermostat.

G - Cleaning Heat Exchanger Assembly

! IMPORTANT

Use papers or protective covering in front of furnace while removing heat exchanger assembly.

! WARNING

If unit has been operating, internal components will be HOT. Allow unit to cool for at least 15 minutes before placing hands into the heat section opening. To completely cool to room temperature, the blower should run continuously for about 40 minutes.

- 1- Turn off both electrical and gas power supplies to furnace.
- 2- Remove upper and lower furnace access panels.
- 3- Remove air decoupler box cover.
- 4- Remove insulation pieces from lower section of air decoupler box.
- 5- Unscrew air valve housing, using your hand. Use either a strap or basin wrench if necessary.
- 6- Disconnect wiring to purge blower.
- 7- Remove nut from PVC air inlet fitting.
- 8- Remove nuts from air decoupler box mounting bolts and gas decoupler bracket.
- 9- Remove air decoupler box from unit.
- 10- Remove rubber gaskets and pad from air pipe.
- 11- Detach PVC exhaust pipe from coil manifold outlet.
- 12- Disconnect gas to unit.
- 13- Disconnect wiring to gas valve.
- 14- Break union in gas line just below gas decoupler. Remove gas valve / gas decoupler / piping assembly.
- 15- Remove remaining gas piping from fitting at vestibule panel.

! IMPORTANT

Hex head fitting contains gas diaphragm valve. Care must be taken when handling this portion of piping assembly.

- 16- Disconnect blower motor wires from control box.
- 17- Disconnect spark plug and sensor wires from plugs in combustion chamber. (Access plate is provided.)
- 18- Remove vest panel.
- 19- From underside of blower deck, remove four nuts holding rubber heat train mounts.
- 20- Lift heat train from unit.
- 21- Backflush heat train with a soapy water solution or steam clean.

! IMPORTANT

If unit is backflushed with water, make sure all water is drained from heat train before replacing. Use papers or protective covering in front of furnace.

- 22- Reverse above steps to replace heat exchanger assembly. Be sure rubber seal pad and gasket are in place on air pipe and that ground wire on gas valve is put back on. Air flapper valve housing should be hand tightened only.

V - UNIT CHECKOUT

A - Temperature Rise

Temperature rise for G21/GSR21 units depends on unit output, blower speed and static pressure of unit setup. Blower speed must be set for unit operation within range of "AIR TEMP. RISE °F" listed on unit rating plate.

To Measure Temperature Rise:

- 1- Place plenum thermometers in supply and return air plenums. Locate thermometers in the first horizontal run of the warm air plenum where it will not pick up radiant heat from the heat exchanger.
- 2- Set thermostat to highest setting.
- 3- After plenum thermometers have reached their highest and steadiest readings, subtract the two readings. The difference should be in the range listed on the unit rating plate. First check the firing rate. If temperature is too high, provided the firing rate is acceptable, increase blower speed to reduce temperature. If the temperature is too low, decrease blower speed. To change blower speed taps see the Blower Speed Taps section in this manual.

B - External Static Pressure

- 1 - Measure tap locations as shown in figure 62.

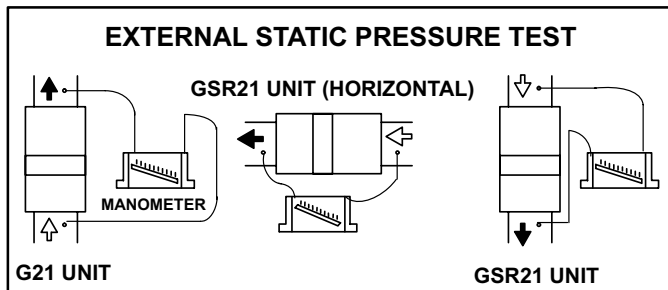

FIGURE 62

- 2 - Punch a 1/4" diameter hole in supply and return air plenums. Insert manometer hose flush with inside edge of hole or insulation. Seal around the hose with permagum. Connect the zero end of the manometer to the discharge (supply) side of the system. On ducted systems, connect the other end of manometer to the return duct as above. For systems with non-ducted returns, leave the other end of the manometer open to the atmosphere.
- 3 - With only the blower motor running and a dry evaporator coil, observe manometer reading. Adjust blower motor speed to deliver required amount of air.
- 4 - External static pressure drop must not be more than 0.5" W.C on "Q" units and 0.8" W.C on "V" units.
- 5 - Seal around the hole when check is complete.

C - Manifold Pressure

Checks of manifold pressure are made as verification of proper regulator adjustment. Manifold pressure for the G21/GSR21 can be measured at any time the gas valve is open and is supplying gas to the unit. Normal manifold pressure is 2.0 ± 0.2 in. W.C. for natural gas and 9.0 ± 0.2 in. W.C. for L.P. gas.

To Measure Manifold Pressure:

- 1 - Remove 1/8" pipe plug from pressure tap on elbow below expansion tank. See figure 23 for location.

! WARNING

For safety, connect a shut-off valve between the manometer and the gas tap to shut off gas pressure to manometer if desired.

- 2 - Insert hose adapter in tap and connect gauge.
- 3 - Set thermostat for heating demand (the demand can be started at the unit by jumping "R" and "W" on the low voltage terminal strip). **BE SURE TO REMOVE THE JUMPER AFTER THE TEST IS COMPLETE.**
- 4 - Check the manifold pressure after the unit has ignited and is operating normally.

- 5 - If the unit is not operational SEE CAUTIONS AND WARNINGS BELOW. Check the manifold pressure immediately after the gas valve fully opens.

- 6 - The gas valve can be adjusted using the regulator adjustment screw. This screw is located under the dust cover screw on the face of the valve next to electrical terminals and manual on/off knob. Refer to figure 24.

! WARNING

Disconnect heating demand as soon as an accurate reading is obtained and allow unit to post-purge heat exchanger before proceeding.

! DANGER

Combustion chamber access panel and air decoupler box cover must be in place for this test. Do not allow long periods of trial for ignition. Unsafe conditions could result.

! WARNING

If unit is not operational, a manifold pressure check should be used only to verify that gas is flowing to combustion chamber at correct manifold pressure. Always allow purge blower to evacuate combustion chamber before proceeding.

D - Line Pressure

Gas supply pressure should not exceed 13.0 in. W.C. and should not drop below 3.5 in. W.C. Normal natural gas level for G21/GSR21 units is 7.0 in. W.C. and 11.0 in. W.C. for L.P. units. Supply pressure should only be checked with unit running. A 1/8" pipe plug and tap are supplied in the elbow on the inlet supply of the gas valve. Line pressure ratings are listed on unit rating plate.

E - Flame Signal

Flame signal or microamp is an electrical current which passes from the ignition control through the sensor electrode during unit operation. Current passes from the sensor through the flame to ground to complete a safety circuit. A 50 microamp DC meter is needed to check flame signal for GC-1 equipped units. GC-3 units require a digital meter and a transducer (Part no. 78H5401).

In a standard gas furnace, flame sensing is measured in a steady flame. A "Pulse" furnace does not have a steady flame to measure. Current can only be measured during pulse cycles. Between cycles, no current can be measured. Since the pulse rate approximates 60 pulses per second, the flame sensor measures an electrical average of the flame pulses.

To Measure Flame Signal-GC-1 Ignition Control:

⚠ WARNING

Fire and explosion hazard.

These instructions MUST be followed exactly.

Can cause a fire or explosion resulting in property damage, personal injury or loss of life.

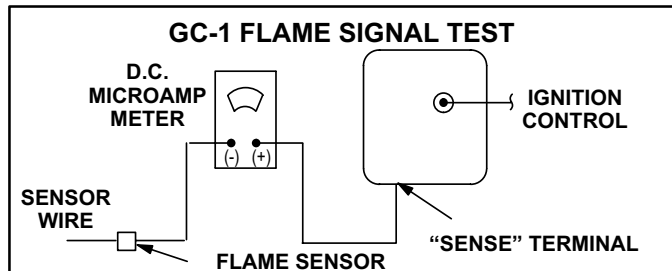

FIGURE 63

- 1 - Place meter in series between ignition control and sensor wire. Connect positive (+) lead of meter to ignition control sensor connection and negative (-) lead of the meter to sensor wire. See figure 63.
- 2 - Set thermostat for a heating demand and check flame signal with unit operating. For G21/GSR21 series with the GC-1 ignition control (A3), a reading of 3 to 5 microamps DC is typical. The control will operate between 1 and 5 microamps DC.

Flame signal may rise above 3 to 5 microamps for the first few seconds after ignition and then level off.

To Measure Flame Signal-GC-3/G891 Ignition Controls:

A transducer (Part #78H5401 available from Lennox Repair Parts) is required to measure flame signal on GC-3 / G891

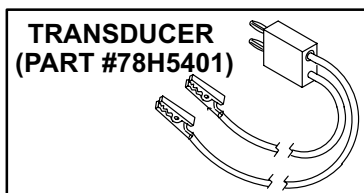

FIGURE 64

equipped units. See figure 64. The transducer converts microamps to volts on a 1:1 conversion. GC-3 flame signal is 1.5-2.5 microamps, therefore a reading of 1.5-2.5 volts should be read on the meter. G891 flame signal is 1.2-2.2 microamps, therefore a reading of 1.2-2.2 volts should be read on the meter. The transducer plugs into the meter. See figure 66 for proper use of transducer.

- 1 - Set the volt meter to the DC voltage scale. Insert transducer into the VDC and common inputs. Observe correct polarities. Failure to do so results in negative (-) values.

- 2 - Turn off supply voltage to control.
- 3 - Disconnect flame sensor lead from terminal of ignition control.
- 4 - Connect (+) lead of transducer to ignition control sensor connection. See figure 65.
- 5 - Connect (-) lead of the transducer to sensor wire. See figure 65.
- 6 - Turn supply voltage on and close thermostat contacts to cycle system.
- 7 - When unit lights read voltage on meter display. Remember 1 DC volt = 1 DC microamp. For G21/GSR21 series with the GC-3 ignition control (A3), a reading of 1.5-2.5 volts DC should occur. For G21/GSR21 series with the G891 ignition control (A3), a reading of 1.2-2.2 volts DC should occur.

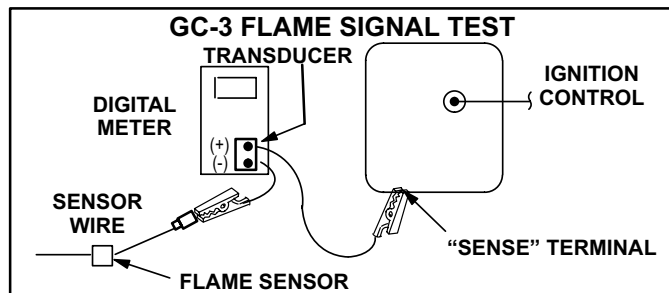

FIGURE 65

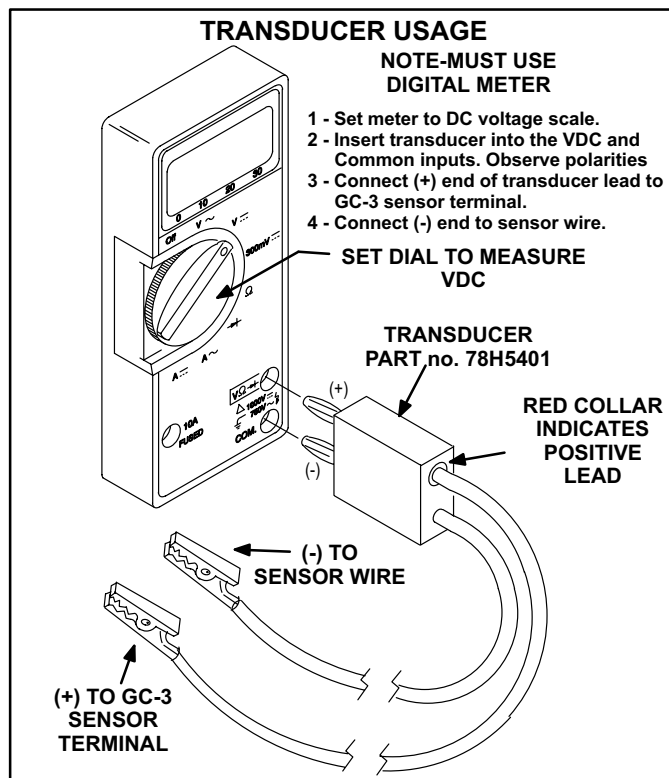

FIGURE 66

F - Exhaust CO₂ (Carbon Dioxide) Content

Carbon Dioxide is a colorless and odorless gas produced in small amounts by all furnaces during the combustion process. When the unit is properly installed and operating normally CO₂ content of the exhaust gas is within 8.0-10.0 percent for natural gas and 9.0-11.5 percent for L.P. gases. If the unit appears to be operating normally at or beyond the upper limit of the CO₂ range, the unit should be checked for abnormally high CO (Carbon Monoxide) output which might indicate other problems in the system.

One method of measuring the CO₂ content is to use the Bacharach CO₂ test with a Fyrite CO₂ indicator. Other methods of testing CO₂ are available. Closely follow the instructions included with the test kit that you choose. A method for connecting the CO₂ test kit to the GSR21 is outlined in the next section.

G - Exhaust CO (Carbon Monoxide) Content

If the unit appears to be operating normally with the CO₂ levels at or near the upper limits listed in section F, the unit should be checked for abnormally high CO content. When the unit is properly installed and operating normally, the CO content of the exhaust gas is less than 0.04 percent (400 PPM) regardless of the type of gas used.

! WARNING

High CO output may be fatal.

Do not allow unit to operate at CO output levels above 0.04 percent.

The source of improper combustion must be located and corrected.

Conditions Which May Cause Abnormally High CO:

- 1 - Partial blockage of exhaust pipe and intake pipe;
- 2 - Abnormally high exhaust back pressure and intake restriction due to pipe length or routing;
- 3 - Dirty or worn air flapper. (Air flapper should be checked and replaced if needed.)

H - Testing Exhaust CO₂/CO Content

Use the following as a guide to test for abnormally high CO₂/CO content.

To Measure CO₂/CO Content:

- 1 - Drill size "R" or 11/32" in. hole on top of the exhaust outlet PVC elbow (inside unit cabinet) and tap 1/8-27 NPT as shown in figure 67. This hole is used as the CO₂/CO test port.
- 2 - Install a hose barb into the test port. See figure 67.

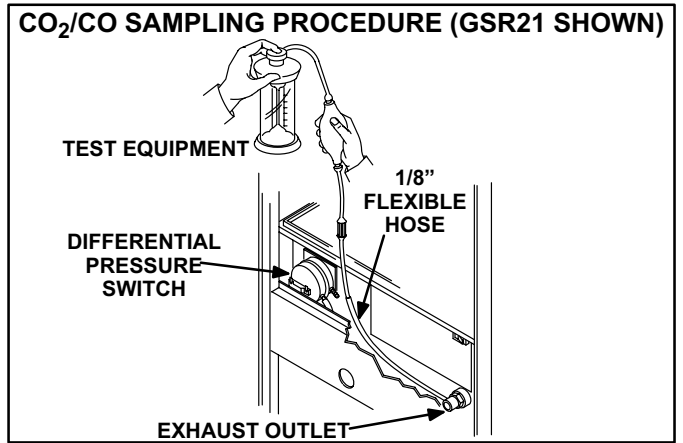

FIGURE 67

- 3 - Attach end of Fyrite sampling tube to hose barb on exhaust outlet elbow.
- 4 - Set unit to highest setting and allow unit to run for 15 minutes.
- 5 - When CO₂/CO testing is complete, turn off unit, remove hose barb from exhaust outlet elbow and use a 1/8" pipe plug to close off the test port.

! WARNING

The exhaust vent pipe operates under positive pressure. Completely seal 1/8" NPT plug to prevent leakage of combustion products into the living space.

I - Heat Exchanger Temperatures

During operation, temperature at the top of the combustion chamber and tailpipe is 1,000 to 1,200 °F. At the tailpipe entrance to the exhaust decoupler, temperature has dropped to approximately 600°F. Temperature from the exhaust decoupler outlet to coil intake manifold is 350 °F. At the coil exhaust outlet manifold, temperature range is approximately 100 to 120 °F. These are average temperatures and will vary with blower speed input.

J - Exhaust Temperature Range

Exhaust temperature range should not exceed 135 °F for any of the G21/GSR21 series units. If it does, the high exhaust temperature may cause the unit to trip out on limit.

Most units run with a maximum exhaust temperature of 110° F to 135° F for lower to higher unit inputs. Maximum temperatures are listed in table 15.

TABLE 15

MAXIMUM EXHAUST TEMPERATURES	
UNIT	LIMIT SETTING
G21/GSR21-50	115°
G21/GSR21-60	120°
G21/GSR21-80	125°
GSR21-10	130°
G21-100	135°

K - Condensate pH Range

Unit condensate is mildly acidic and can be measured with pH indicators. The pH scale as shown in figure 68 is a measurement of acidity or alkalinity.

Concentration of acidity of all these fluids including condensate is very low and harmless.

The following scale shows relative pH of some common liquids as compared with G21/GSR21 condensate.

pH RANGE	
Increasing Acidity ↑	0
	1
	2- Vinegar
	3- Wine
	4- Orange Juice
	5- Tomato Juice
	6
	7- tap water
Increasing Alkalinity ↓	8
	9
	10
	11
	12
	13
	13
	14

FIGURE 68

L - Acceptable Operating Input

Field adjustments to the unit are not normally needed due to specifically sized components for each input rating.

Unit may run up to ± 3 to 4 percent of rated input (listed on unit nameplate) due to installation variables such as temperature rise, external static pressure and return air temperature combined with allowable tolerances of components within unit. This is an acceptable operating range.

Operation of the G21/GSR21 above or below this acceptable operating range may cause continuity, start-up and lock-out problems (erratic operation). Overfiring the unit can shorten the life of the heat exchanger assembly. Overfiring can be checked by measuring unit's input.

! IMPORTANT

Overfiring the unit can shorten the life of the heat exchanger assembly

For new units, approximate input measurements may be obtained after allowing unit to run continuously for 15 minutes. If accurate input measurements are required, the following procedure may be used. Accurate input measurements requires time for the unit to "run in."

Run in time allows flapper valves to seat and combustion to clean the protective layer of oil residue that may be present from inside surfaces of the heat exchanger assembly. This process stabilizes combustion rate and may take one to two hours of continuous operation. Since it is impractical to operate an installed unit for one to two hours continuously, the unit should be allowed to operate normally, (cycle on demand) for a period to accumulate several total hours of run time to obtain an accurate measurement of input. Overnight operation should provide enough total run time to obtain an accurate measurement of input. Just prior to any input check, run unit continuously for 15 minutes.

M - Checking Gas Input-Determine Gas Flow at Meter

- 1 - Turn off all other gas appliances, including pilot lights or appliances if used.
- 2 - For single stage "V" units jumper HB to W2.
- 3 - Set thermostat to highest setting and allow unit to run continuously for 15 minutes. A 15 minute run time is needed to allow unit operating rate to stabilize.
- 4 - At the gas supply meter and using either one-, two-, three- or five-foot dial on the meter, time one full revolution (in seconds) with a watch. See figure 69.

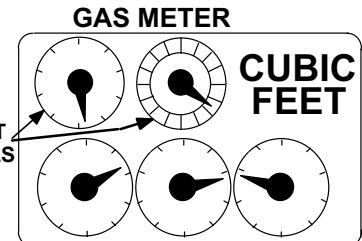

FIGURE 69

- 5 - Find the number of seconds for one revolution on the Gas Rate chart, see table 16. Read the cubic feet for matching one-, two-, three- or five-foot dial size from table 16 multiply this times Btuh per cubic foot content of the gas. The result is total gas Btuh input.
- 6 - Check Btuh input figure against Btuh listed on unit nameplate.

**TABLE 16
METER FLOW RATE**

GAS RATE- CUBIC FEET PER HOUR													
Secs for One Rev.	Size of Test Dial			Secs for One Rev.	Size of Test Dial			Secs for One Rev.	Size of Test Dial		Secs for One Rev.	Size of Test Dial	
	1 cu. ft.	2 cu. ft.	5 cu. ft.		1 cu. ft.	2 cu. ft.	5 cu. ft.		2 cu. ft.	5 cu. ft.		2 cu. ft.	5 cu. ft.
10	360	720	1800	34	106	212	529	62	116	290	110	-	164
11	327	655	1636	35	103	206	514	64	112	281	112	64	161
12	300	600	1500	36	100	200	500	66	109	273	116	62	155
13	277	555	1385	37	97	195	486	68	106	265	120	60	150
14	257	514	1286	38	95	189	479	70	103	257	125	-	144
15	240	480	1200	39	92	185	462	72	100	250	130	-	138
16	225	450	1125	40	90	180	450	74	97	243	135	-	132
17	212	424	1059	41	-	176	439	76	95	237	140	-	129
18	200	400	1000	42	86	172	429	78	92	231	145	-	124
19	189	379	947	43	-	167	419	80	90	225	150	-	120
20	180	360	900	44	82	164	409	82	88	220	155	-	116
21	171	343	857	45	80	160	400	84	86	214	160	-	113
22	164	327	818	46	78	157	391	86	84	209	165	-	109
23	157	313	783	47	-	153	383	88	82	205	170	-	106
24	150	300	750	48	75	150	375	90	80	200	175	-	103
25	144	288	720	49	-	147	367	92	78	196	180	-	100
26	138	277	692	50	72	144	360	94	-	192	-	-	-
27	133	267	667	-	-	-	-	96	75	188	51	141	353
28	129	257	643	52	69	138	346	98	-	184	53	136	340
29	124	248	621	54	67	133	333	100	72	180	55	131	327
30	120	240	600	56	64	129	321	102	-	176	57	126	316
31	116	232	581	58	62	124	310	104	69	173	59	122	305
32	113	225	563	60	60	120	300	106	-	170	-	-	-
33	109	218	545	-	-	-	-	108	67	167	-	-	-

EXAMPLE:

- a - One revolution of two-foot dial = 90 seconds.
- b - Using the gas rate chart, table 16, note that 90 seconds = 80 cubic feet of gas per hour.
- c - 80 cu. ft./hr. x 1000 Btuh/cu. ft. = 80,000 Btuh input.
- d - Normally there are 1000 Btuh in each cubic foot of gas. Make adjustment to this figure where the gas heating value is other than 1000 Btuh per cubic foot (contact the local gas supplier for local Btuh per cubic foot ratings).

**N - Checking Air Intake and Flapper Valve
Figures 70, 71 and 72**

- 1 - Remove air intake chamber cover and check foreign materials that may have accumulated, clean purge blower and upper and lower chamber compartment if necessary .
- 2 - Do not remove air flapper valve unless it is suspected of being faulty.
If valve must be removed, carefully remove the eight screws holding air intake flapper valve to valve body. DO NO TURN OR REMOVE CENTER SCREW. Remove valve from unit. CAUTION-DO NOT DROP.
- 3 - EXTREME CARE SHOULD BE TAKEN WHEN DISASSEMBLING INTERNAL COMPONENTS OF THE VALVE. If taken apart, plates could be rotated out of phase or reversed. Spacer thickness has an extremely low tolerance. Note that each plate has a stamp of the spacer thickness and a star or the words "THIS SIDE OUT." These stamps should all lie in the same quadrant and face the outside of unit. See figures 71 and 72. Newer air flapper valve assemblies for the -40 / 50 / 60 / 80 contains a plate made from PPS thermoplastic with a

grooved surface on one side. The grooved surface should be facing towards the flapper. Earlier -40/50/60/80 models will have a stainless steel back plate with a star stamped on the surface. This star must face away from the flapper when assembled. On all -40/50/60/80 models, the front plate will have a stamp and star on the surface and must face away from flapper.

- 4 - Visually inspect flapper. On new units, the flapper may not be perfectly flat, it may be curved or dished between the plates. This is normal. On units that have had sufficient run in time, the flapper will be flat. If the flapper is torn, creased or has uneven (frayed) edges, the material must be replaced. A flapper material is available from Lennox Repair Parts. Flapper should be replaced every four years.
- 5 - To find potential warpage in the plates, check for the required clearance between the flapper and back plate in several places around the circumference of the valve. See figure 73. Use a feeler gauge, starting small and working up to the clearance dimension until the gauge is just about snug.

⚠ WARNING

Do not force feeler gauge between flapper and back plate. Damage to flapper material will occur.

Clearance should be checked in six or eight places around the valve. If valve is out of clearance at any one point, replace the assembly. Required clearance values are listed in table 17. Clearances are updated regularly in Service and Application Notes.

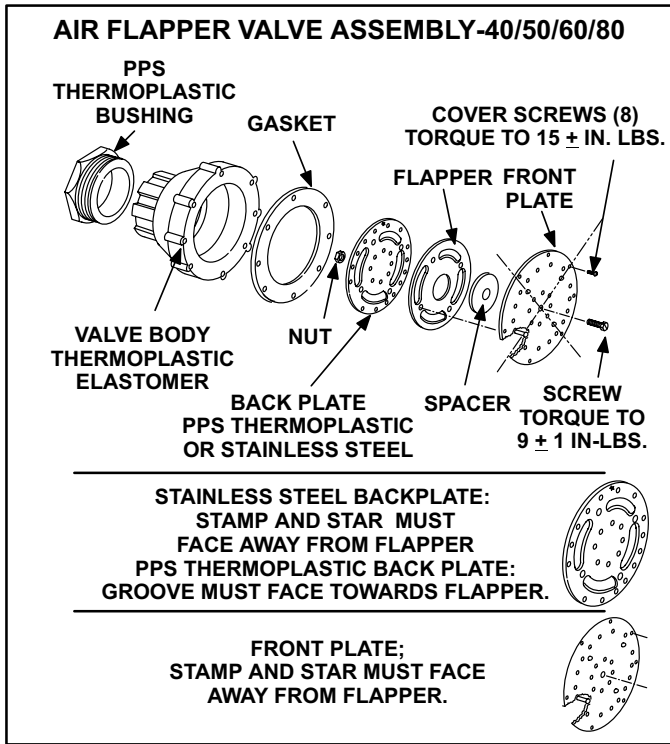

FIGURE 70

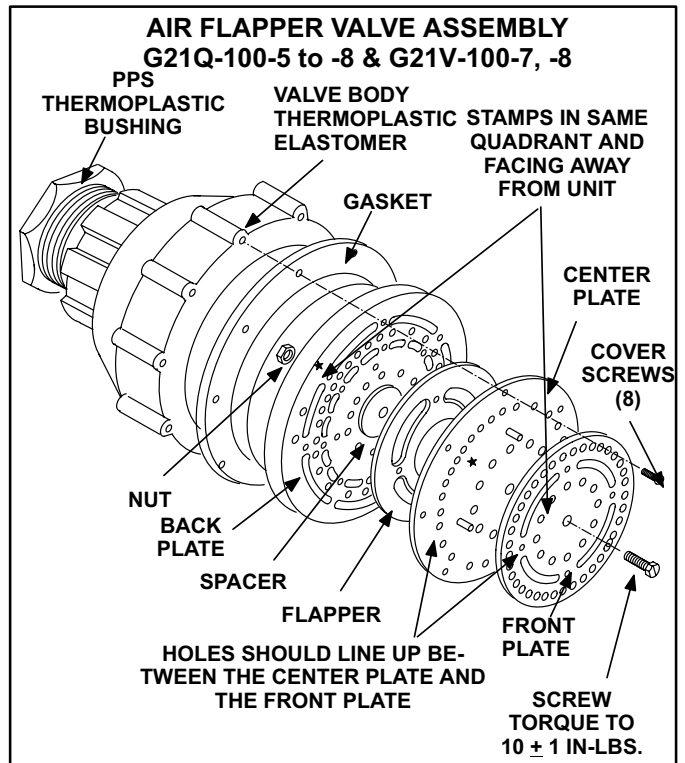

FIGURE 71

⚠ IMPORTANT

Special screws are used in the air flapper valve. Replacement screws are available in kit form from Lennox Repair Parts. Do not use Loctite or similar thread seizing compounds to secure screws.

⚠ WARNING

When servicing the air intake flapper valve, keep in mind that it is only moderately warm during unit operation. After unit cycles off, residual heat in combustion chamber will transfer back to valve causing it to become very hot. Allow it to cool 10 to 15 minutes before handling. The blower can also be run to cool air intake.

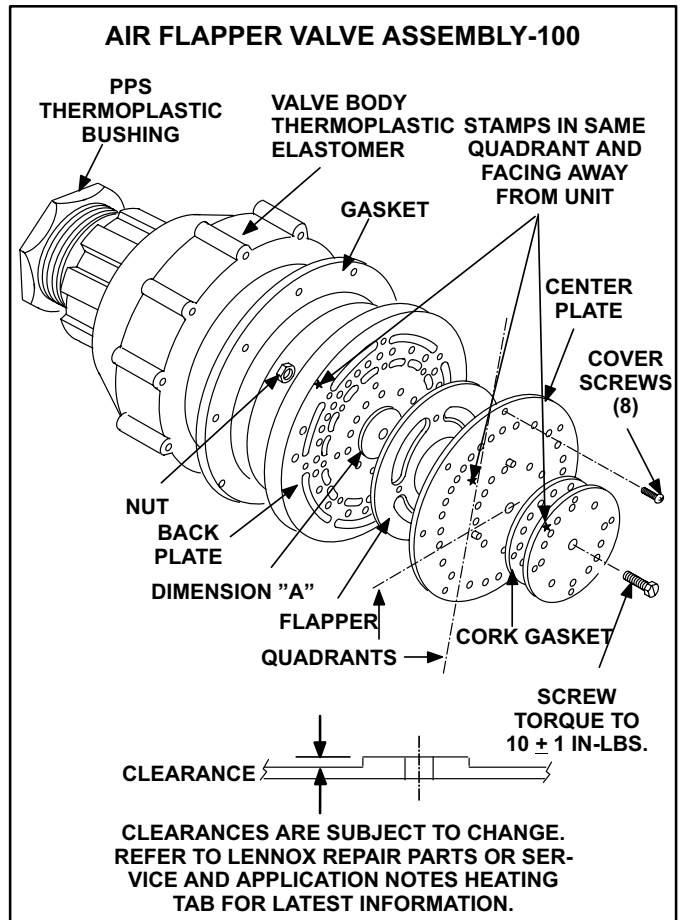

FIGURE 72

TABLE 17

AIR FLAPPER VALVE CLEARANCES (In.)		
Unit	Natural	L.P.G.
G21-40	.031	.040
G21-60	.035	.035
G21-80	.0425 or .045	.0425 or .045
G21-100	.037	.039
G21Q-100-5,-6,-7,-8	.040	.040
G21V-7,-8	.040	.040
GSR21-50	.035	.035
GSR21-80	.0425 or .045	.0425 or .045
GSR21-100	.037	.039

- When placing a new or old valve back into the unit, start all eight screws in place by hand. Tighten screws evenly to a maximum of 15 in./lbs. Do not overtighten screws; if threads are damaged the entire valve body will have to be replaced. All eight screws must be in place for proper operation

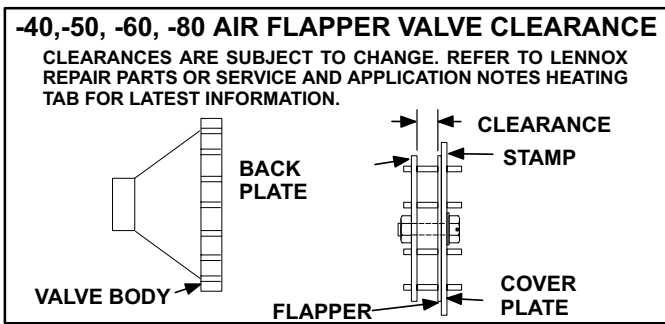

FIGURE 73

O - Checking the Gas Flapper Valve

- Using a plumber's basin wrench, disconnect union at bottom of expansion tank and remove entire gas flapper valve, nipple and elbow assembly as one piece. It is not recommended to remove elbow and nipple from flapper unless the valve is being replaced. Use care not to damage o-ring when handling valve out of unit. DO NOT DROP.
- Do not turn or remove center screw of valve assembly. Visually inspect the flapper. The flapper may be dished or curved on new units, this is normal. In units with "run in" time, the flapper will be flat. If the flapper is torn, creased or has uneven (frayed) edges, the valve assembly must be replaced.
- Check for free movement of the flapper over the spacer. Use a feeler gauge blade to carefully move the flapper between the plates. Be sure the flapper is not trapped between the spacer and the other clearance plate. If the flapper does not move freely or is trapped under the spacer, the valve assembly must be replaced.
- Check for the required clearance between the flapper and valve body. Required clearance values for G21/GSR21 units are 0.024 ± 0.003 in. Use a feeler gauge, starting small and working up to the clearance dimensions until the gauge is just about snug. Do not force

gauge. Check clearance around the valve in several places. If the valve is out of the required clearance dimension given in figure at any point around the valve, it must be replaced.

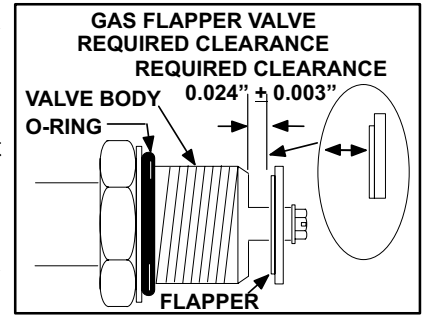

FIGURE 74

! WARNING

Do not force feeler gauge between flapper and valve body. Damage to flapper material will occur.

- When placing a new or old valve back into the unit, use care not to damage the o-ring. DO NOT USE PIPE SEALERS ON THE FLAPPER VALVE THREADS.

P - Checking Gas Orifice

- With gas flapper valve assembly removed, use a flashlight to check for blockage of the orifice in the manifold. To remove the orifice, most units use a 1/2 inch shallow socket with an extension.
- Check the orifice drill size for the unit as given in the Service and Application notes. Make sure orifice diameter matches the drill size stamped on the orifice. If the orifice is incorrect it must be replaced.
- Refer to figure for the physical characteristics of the orifice. The surface must be flat and the orifice opening must not be chamfered. The orifice taper must be centered and not recessed. G21/GSR21 units use a double-coned orifice to improve operating characteristics. If any defects are found the orifice must be replaced.

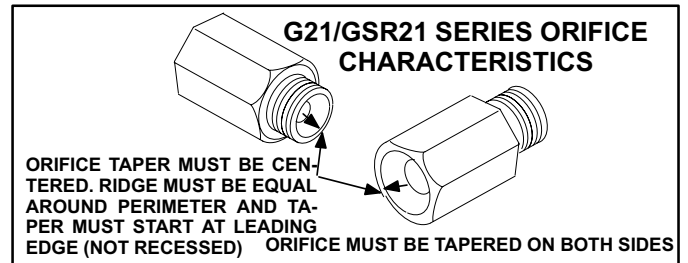

FIGURE 75

- Standard atmospheric burner orifices or orifice blanks cannot be used as replacements for the G21/ GSR21. Only replacement orifices supplied through Lennox should be used.
- When threading the orifice into the manifold use a socket to hold threads beyond end of socket.

! IMPORTANT

To avoid cross threading, carefully align threads by hand turning socket extension until orifice is in place.

VI - TROUBLESHOOTING

IMPORTANT

Normal set-up conditions of a new unit installation require running the unit through several tries for ignition before the unit will run continuously. Initially the unit may start and die several times until air bleeds from gas piping. Break and remake thermostat demand to restart ignition sequence at 2 to 3 minute intervals until continuous operation is obtained.

Effective troubleshooting of the G21/GSR21 depends on a thorough understanding of all unit components and their function as described in this manual. The main troubleshooting categories are:

- Unit Will Not Run Electrical Checks
- Unit Will Not Run Ignition Control Checkout
- Unit Will Not Run Gas, Spark and Air Checks
- “V” Blower and VSP1/2 Troubleshooting
- Unit Sputter Starts And Dies.
- Unit Starts Clean But Runs Less Than 10 Seconds.

EACH OF THE PROBLEM CATEGORIES ARE BROKEN DOWN INTO TROUBLESHOOTING FLOWCHARTS LOCATED IN section VII - TROUBLESHOOTING FLOWCHARTS in the back of this manual, with additional information provided to explain certain checks. Steps in the flow charts for measuring manifold pressure, flame signal, exhaust CO₂ content and exhaust CO content and operating input are explained in previous sections.

CHOOSE THE FLOW CHART THAT BEST DESCRIBES THE UNIT'S PROBLEM. FOLLOW THE FLOW CHART STEP BY STEP. At any point a “NO” answer is reached and a repair is made, reassemble the unit and retest for operation. If unit does not operate, recheck that point and then continue through the chart. Occasionally more than one specific problem may exist.

When troubleshooting a unit, be sure that all basic checks are covered carefully. Double check your diagnosis before replacing components. DO AS LITTLE DISASSEMBLY AS POSSIBLE during troubleshooting to prevent introducing additional problems such as gas or air leaks or damage to components.

WARNING

If unit has been operating, internal components will be HOT. Allow unit to cool for at least 15 minutes before placing hands into the heat section opening. To completely cool to room temperature, the blower should run continuously for about 40 minutes.

A - Safety Shutdown

Safety shutdown occurs when any of the problems are encountered.

- 1 - Loss of combustion during a heating cycle caused by:
 - a - Obstruction to air intake piping;
 - b - Obstruction to exhaust outlet piping;
 - c - Low gas pressure;
 - d - Failure of gas flapper valve;
 - e - Failure of air flapper valve;
 - f - Failure of main gas valve;
 - g - Loose spark plug or sensor creating pressure loss;
 - h - Loose sensor wire;
 - i - Watchguard normal operation;
 - j - Modulation control normal operation “V” only single-stage heat.
- 2 - High limit cutout:
 - a - Blower failure;
 - b - Temperature rise too high;
 - c - Restricted filter or return air;
 - d - Restricted supply air plenum.

B - ICM2 Does Not Run

To check-out the ICM blower and the VSP blower control board, begin with the ICM blower. Refer to figure 76 and follow the check-out procedure as outlined. If the blower fails any of these tests, do not attempt to repair the VSM blower. There are no field serviceable parts in this component. Replace the motor and repeat the check-out procedure. To verify proper operation of the VSP, check the board as outlined in the troubleshooting flowcharts on the last page.

If a power interrupt occurs during a demand cycle and the heat exchanger is still hot, the blower may begin cycling on and off with the gas valve when power is restored. This condition may continue until the demand is satisfied. It is recommended that the lower setting of the modulation control (marked FAN OFF) be reduced by 10°F to 20°F if this problem should occur. This condition will not occur in zoned applications.

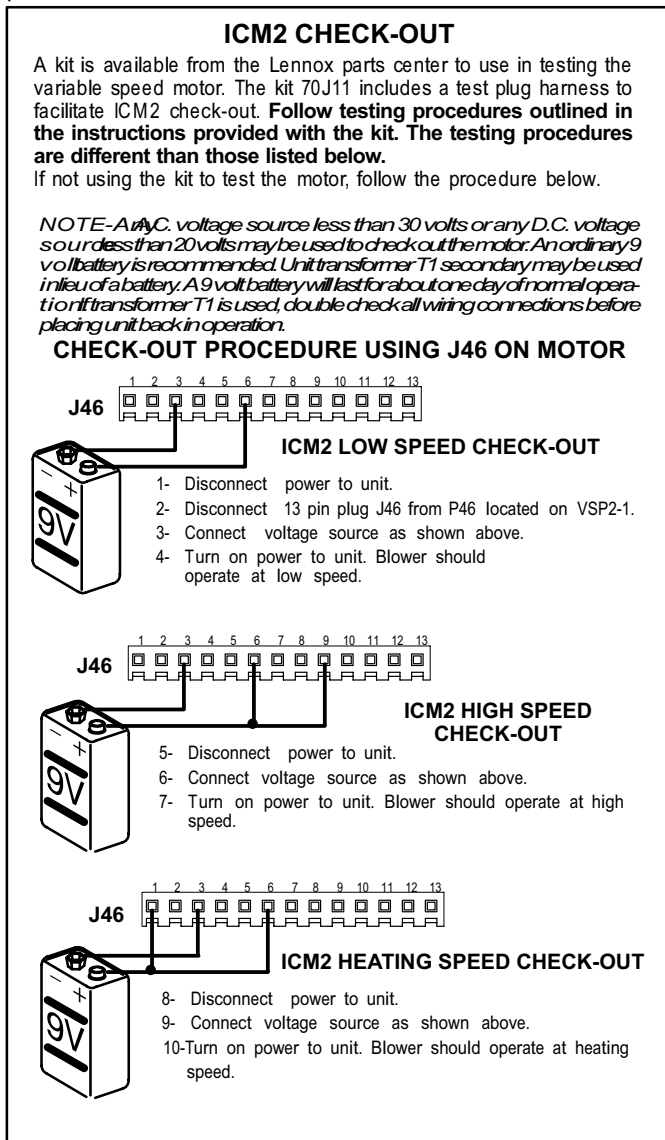

FIGURE 76

C - ICM1 Does Not Run

If the motor does not run the problem could be with the electronically controlled blower motor or the VSP1. Check all connectors and wire terminations for good contact. Figure 77 shows the electronically controlled blower motor and VSP1 check-out procedure. The check-out procedure may be used to determine if either of these components must be replaced. The procedure bypasses the VSP1. If the electronically controlled blower motor does not operate properly it must be replaced. If the electronically controlled blower appears to be operating properly, replace the VSP1. For a detailed troubleshooting chart see G21V/GSR21V "V" Blower and VSP1 Blower Control Board Troubleshooting Flow Chart.

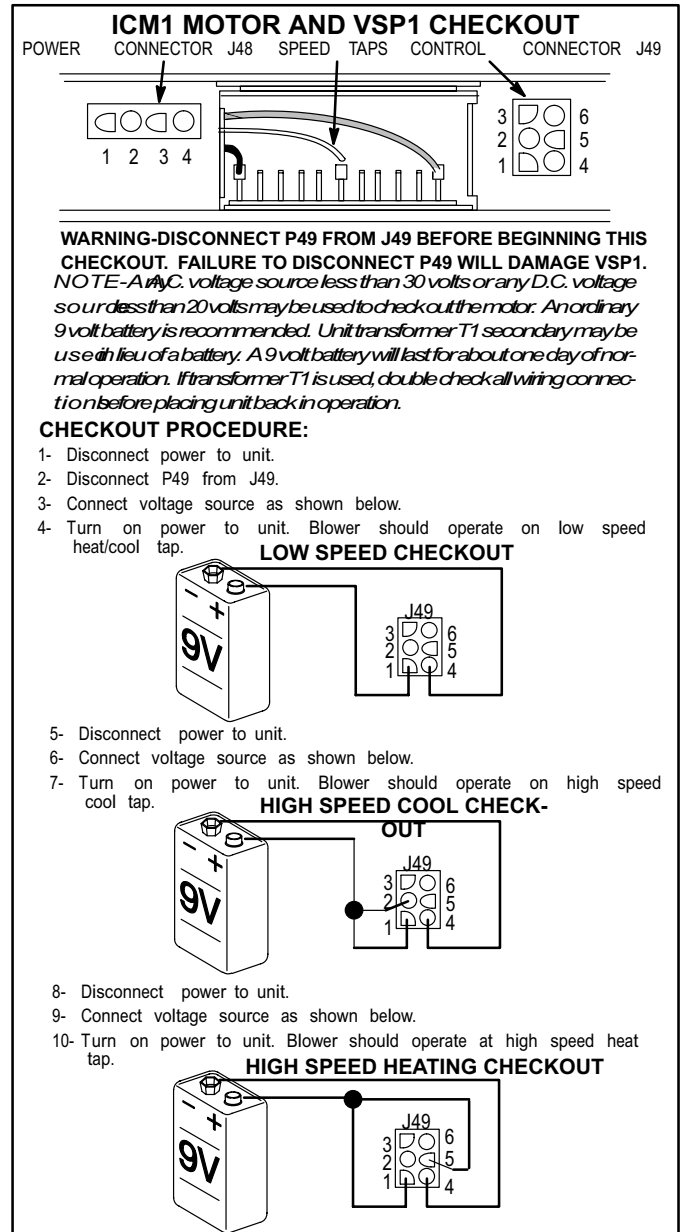

FIGURE 77

D - Blower Runs Continuously “Q” Motor

- 1 - Is thermostat blower switch set to “ON?” If so, switch to “AUTO.”
- 2 - Is blower control “OFF” setting below ambient air temperature? If so, readjust to 90 °F.
- 3 - Is primary blower control operating normally? Replace if necessary.
- 4 - Are blower relay contacts operating normally? Replace if necessary.

E - Supply Air Blower Does Not Run “Q” Motor

- 1 - Check the voltage at the blower motor taps after about 45 seconds.
- 2 - Check for loose wiring.
- 3 - Is blower relay operating properly? Check for 120 VAC between terminal 2 and neutral immediately after ignition. See electrical schematic.
- 4 - Is fan time control relay K36 operating properly? Check for 120VAC between terminal “NO” (normally open) and neutral after the unit has been operating 45 seconds. See electrical schematic.
- 5 - Blower motor and /or capacitor operating normally? Check 120 VAC between the heating motor tap and neutral after the unit has been operating 45 seconds. See electrical schematic. Use standard motor troubleshooting techniques if voltage reaches this point and blower still operates.

F - Unit Does Not Shut Off

- 1 - Is thermostat operating normally?
 - a - Check for shorted 24 VAC control circuit wiring. Repair or replace if necessary.
- 2 - Is the gas valve stuck open?

G - Abnormal Sounds

Corrective action is required if abnormal hissing sounds around the air decoupler are heard. This problem may be caused by:

- 1 - Air leakage around decoupler box cover.
- 2 - Air leakage around air decoupler box cover mounting screws.
- 3 - Air leakage out of the purge blower lead strain relief.
- 4 - Air leakage around the intake air connection to the air decoupler box.
- 5 - Air leakage out of the back of the air decoupler box around the air intake pipe or the air decoupler box rear mounting bolts.

The unit should be examined visually for unusual amounts of condensate in any areas other than the condensing coil outlet which might indicate a system leak.

Abnormal rattling and casing vibration other than obvious loose parts may indicate metal-to-metal contact of components which are normally separated during operation. Gas piping, condensing coil outlet and air intake pipe areas should be checked. Combustion chamber to exhaust decoupler area should also be checked.

DANGER

Extremely loud “pulse” sounds, which can be easily heard through the supply or return air ducts, may indicate a combustion chamber or tailpipe leak. Locate and correct combustion chamber or tailpipe leak before allowing unit to operate.

VII - TROUBLESHOOTING FLOWCHARTS

IGNITION CONTROL CHECKOUT GC1

START HERE

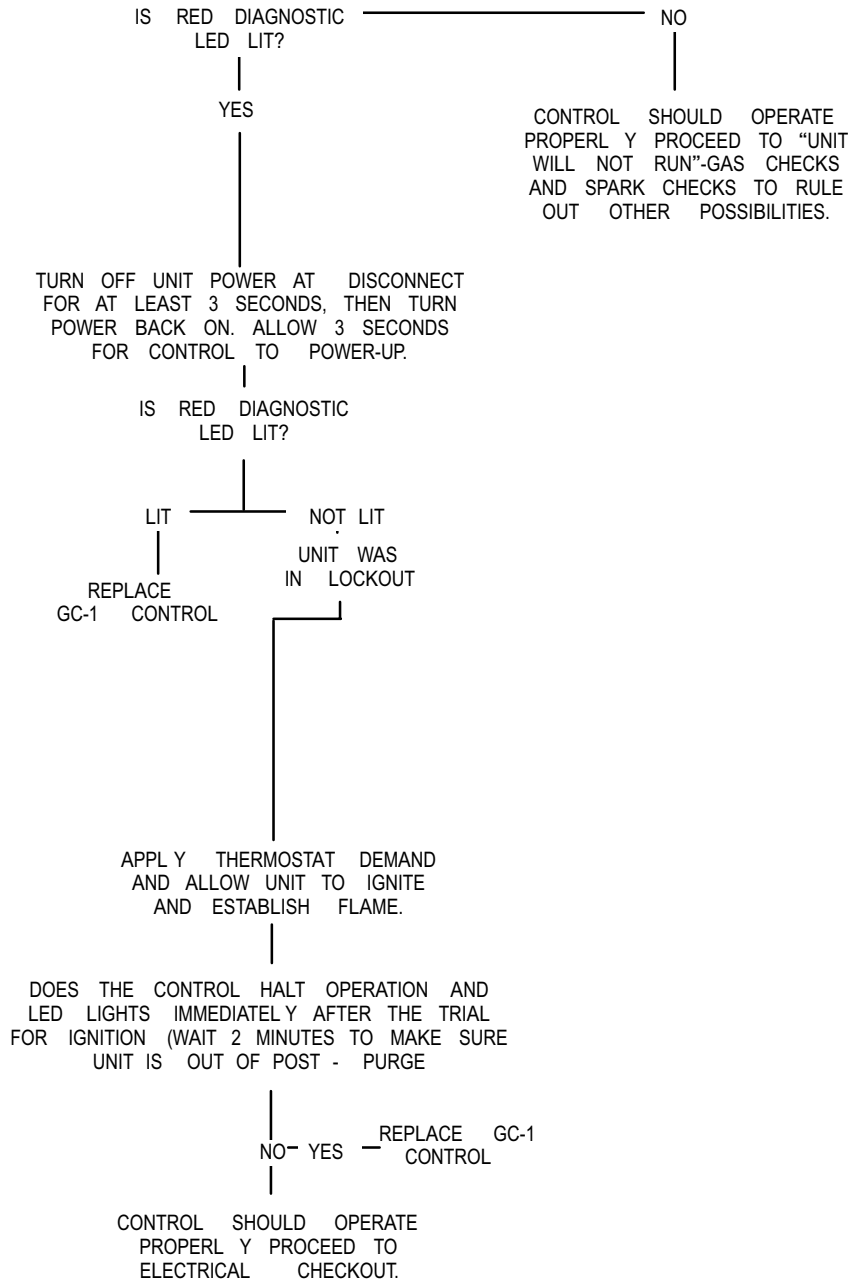

IGNITION CONTROL CHECKOUT GC3

START HERE

IS GREEN DIAGNOSTIC LED LIT?

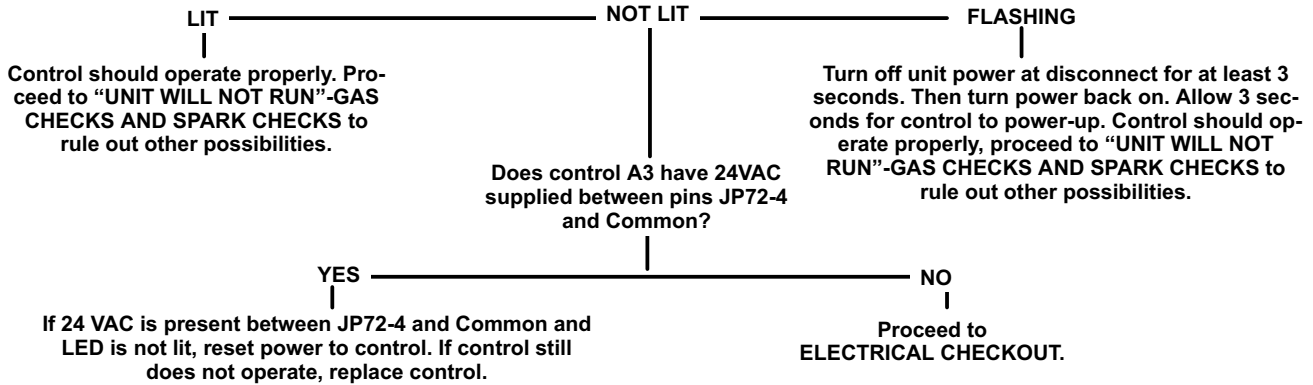

IGNITION CONTROL CHECKOUT G891

START HERE

IS GREEN DIAGNOSTIC LED LIT?

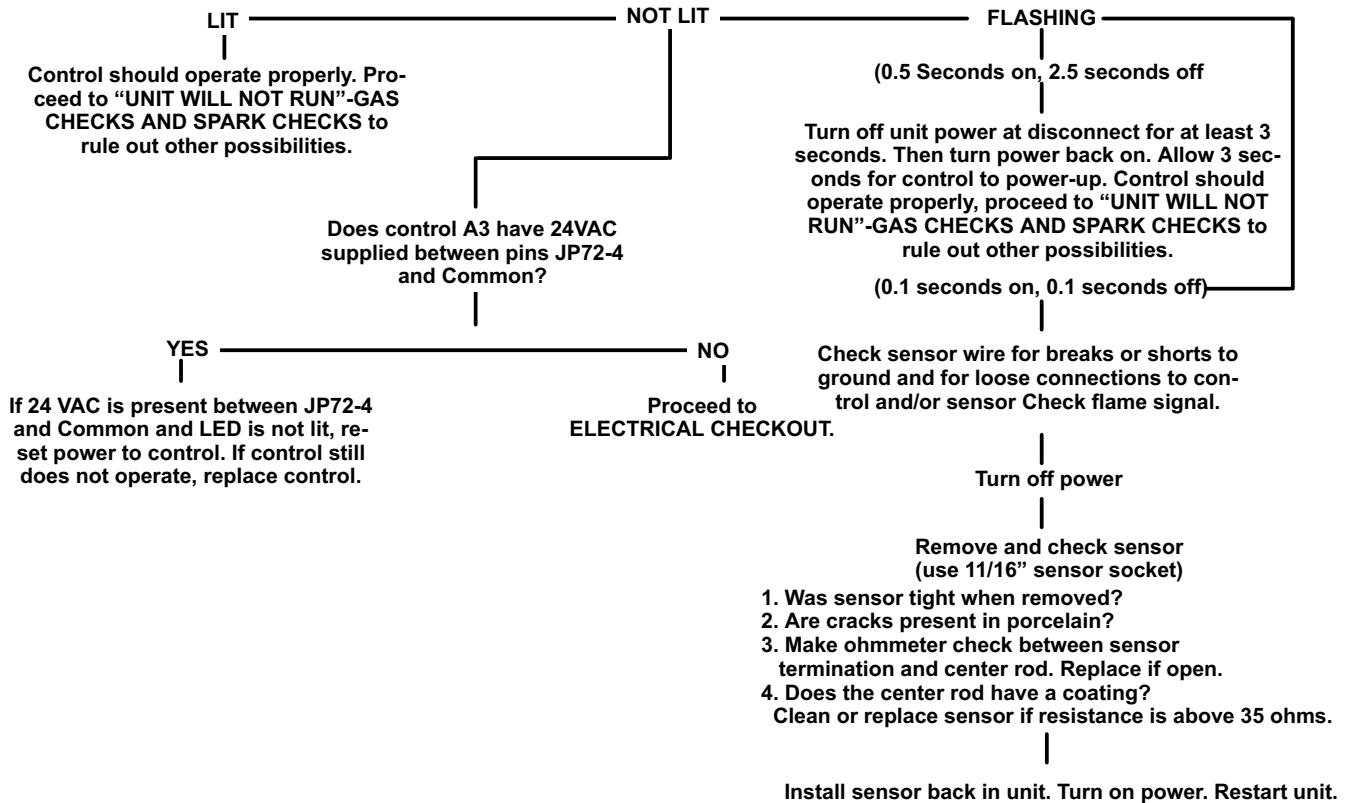

ELECTRICAL CHECKOUT

NOTE- Numbered steps refer to illustrations on page 61.

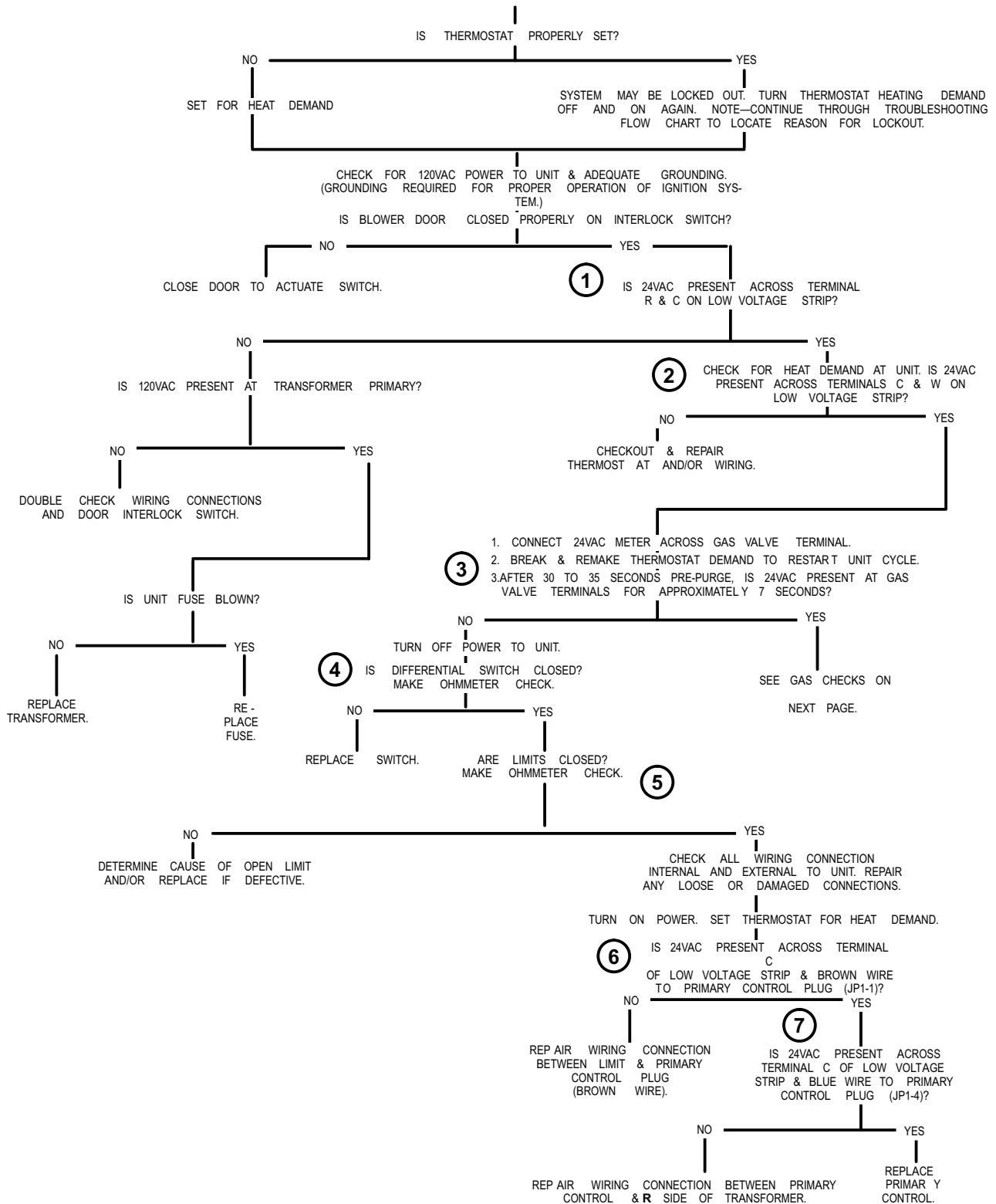

GAS, AIR and SPARK CHECKS

NOTE- Numbered steps refer to illustrations on page 61.

CONTINUED FORM
UNIT WILL NOT RUN
FLOW CHART ON
PREVIOUS PAGE

GAS CHECKS

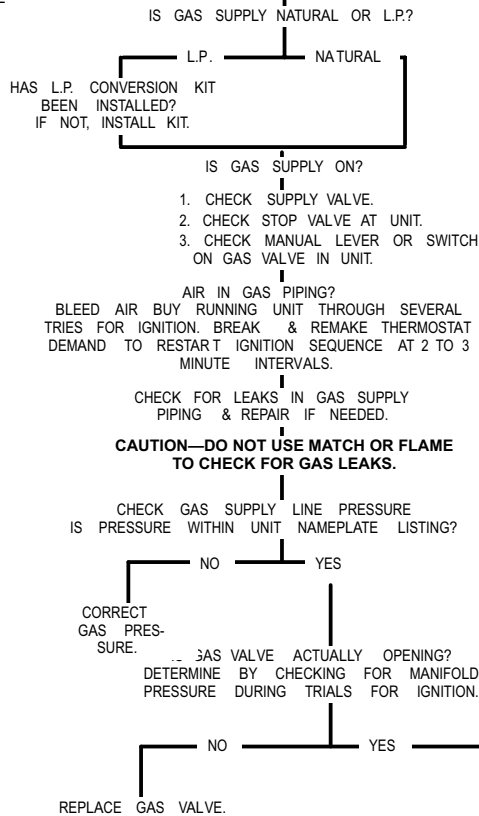

CHECK FOR LEAKS IN UNIT MANIFOLD PIPING.

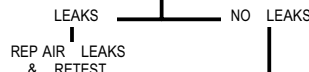

VISUALLY CHECK OUTSIDE TERMINATIONS OF INTAKE & EXHAUST PVC PIPING FOR OBSTRUCTIONS.

VISUALLY CHECK CONDENSATE DRAIN FOR OBSTRUCTIONS.

REFER TO INSTALLATION INSTRUCTIONS: ARE INTAKE & EXHAUST LINES PROPERLY SIZED & APPLIED WITHIN LENGTH, DIAMETER & ELBOW LIMITS?

AIR CHECKS

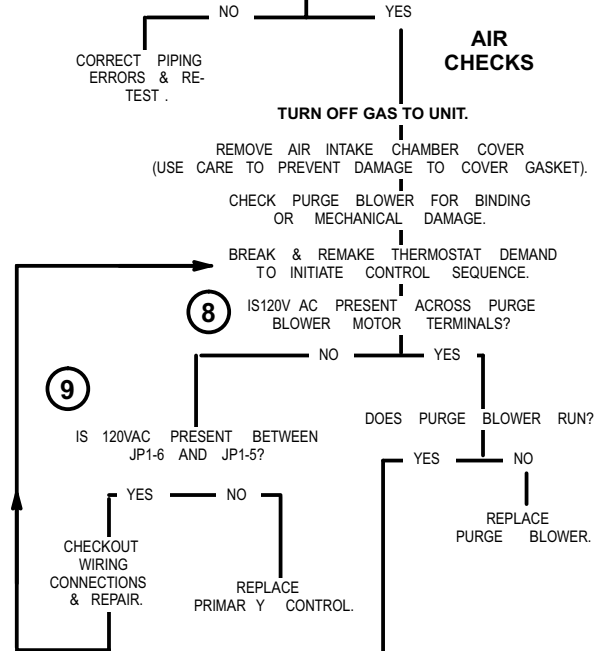

SPARK CHECKS CAUTION—HIGH VOLTAGE

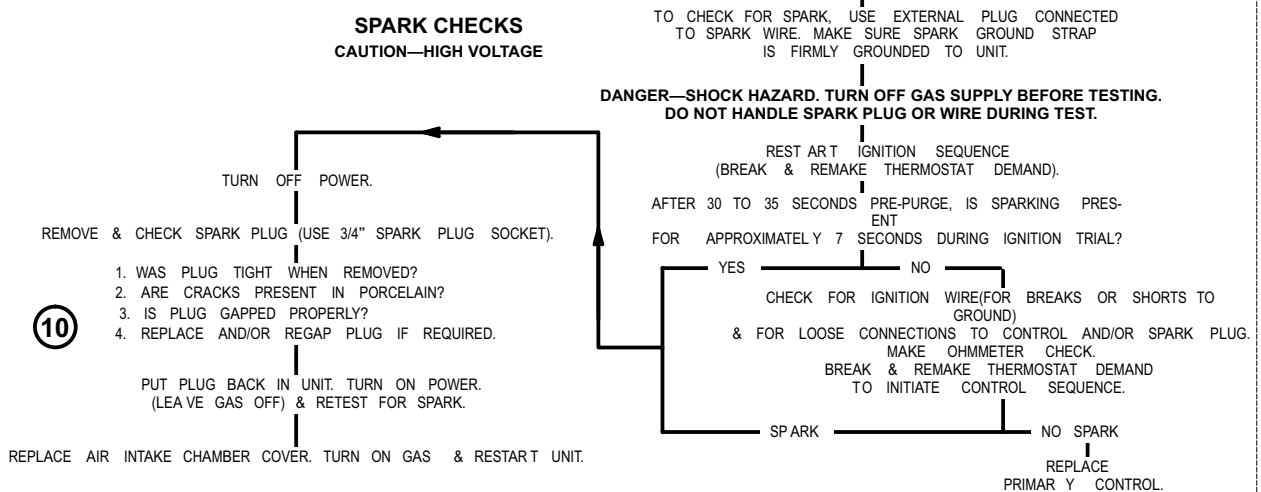

ELECTRICAL TESTING

CHECK VOLTAGE AT TERMINAL AND CHECKING THERMOSTAT DEMAND

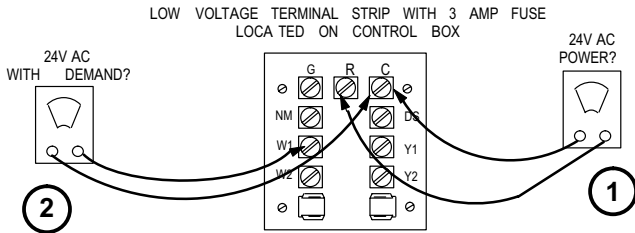

CHECKING VOLTAGE AT PRIMARY CONTROL

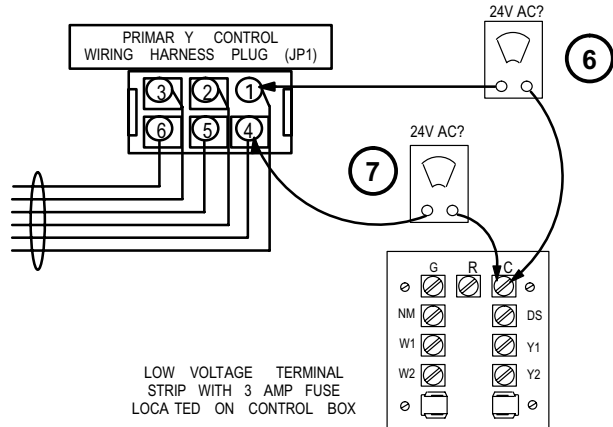

CHECKING VOLTAGE AT GAS VALVE

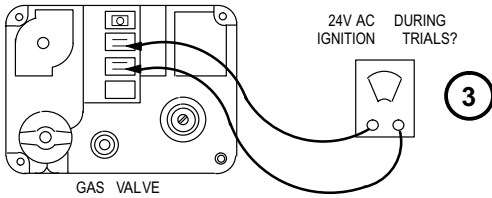

CHECKING VOLTAGE AT PURGE BLOWER

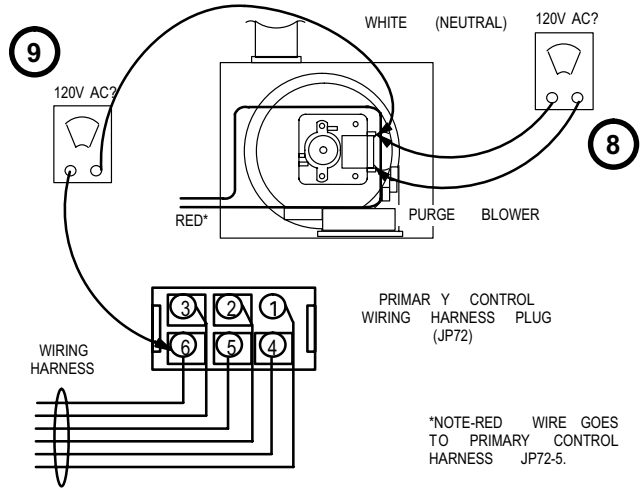

CHECKING FOR OPEN SWITCH

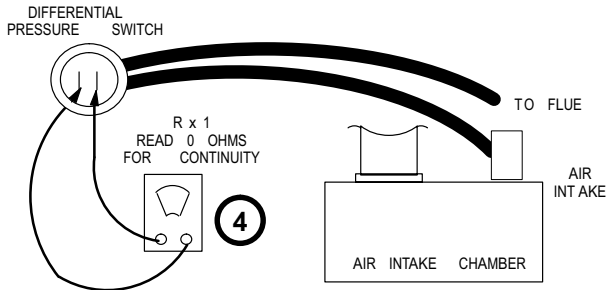

CHECKING FOR OPEN SWITCH IN LIMIT CONTROL

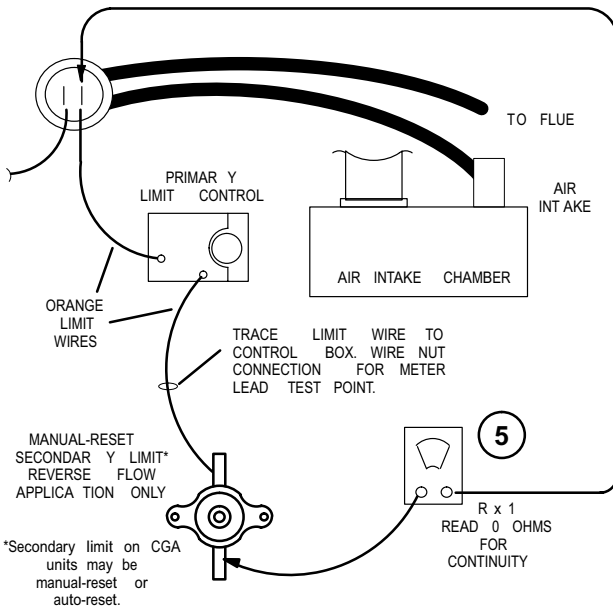

SPARK PLUG

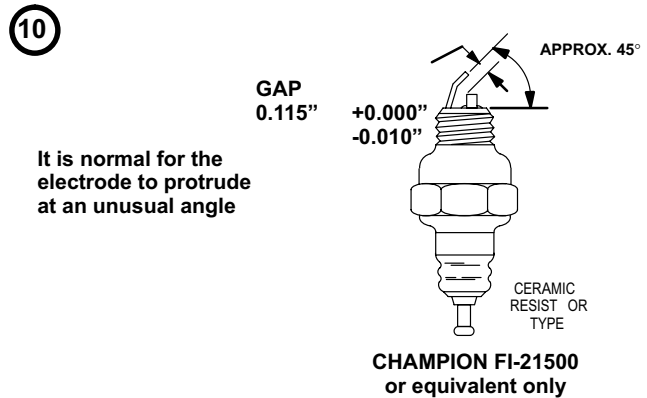

"V" BLOWER ICM2 MOTOR AND VSP2-1 BLOWER CONTROL BOARD TROUBLESHOOTING FLOW CHART

COOLING MODE

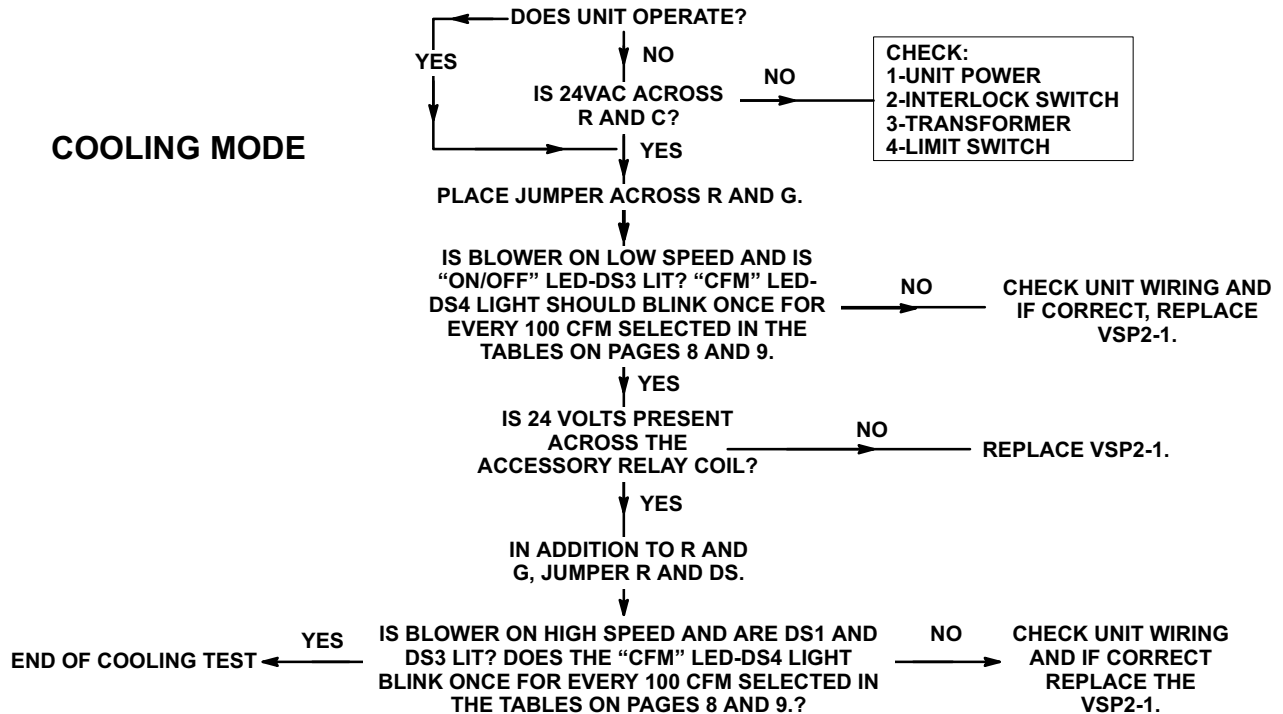

HEATING MODE

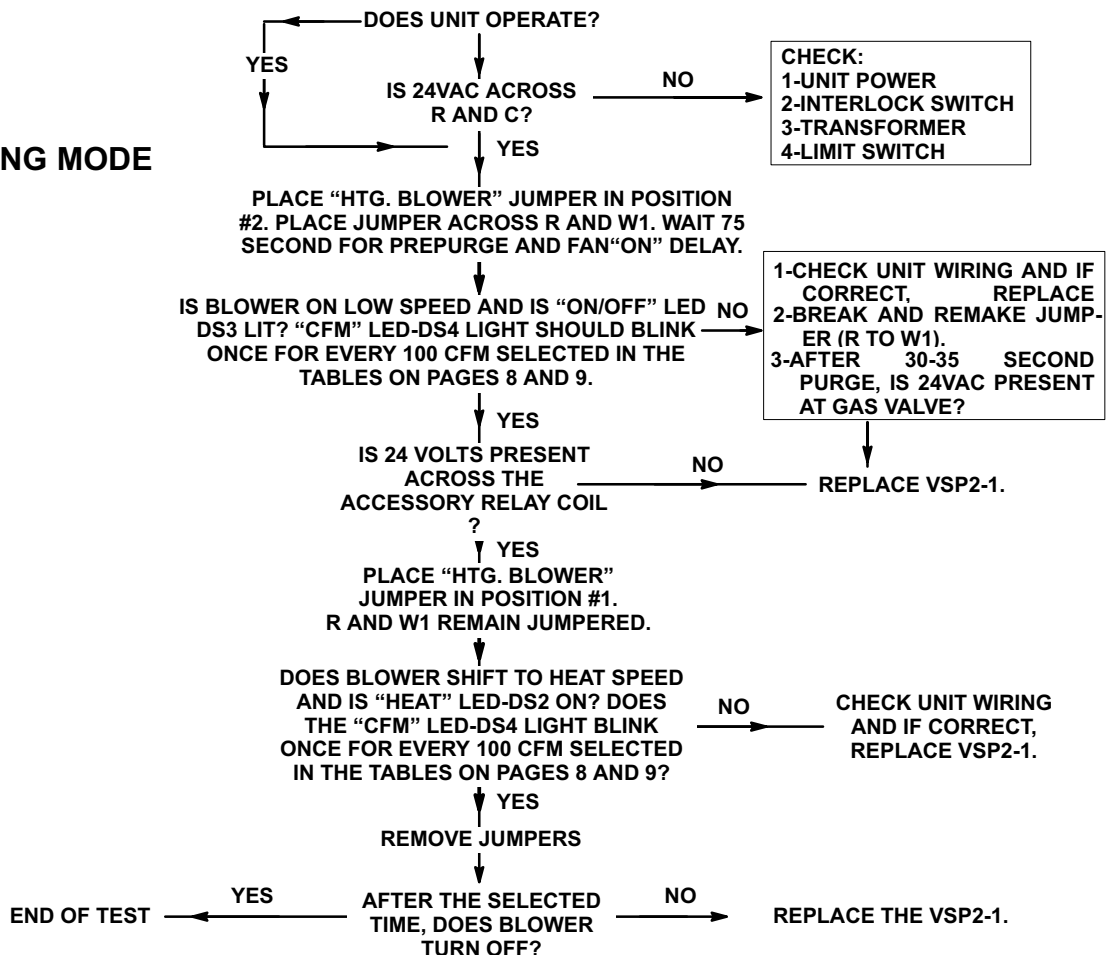

"V" BLOWER AND VSP1 BLOWER CONTROL BOARD HEATING MODE CHECKOUT

START HERE

DOES UNIT OPERATE?
NO
CHECK OUT ELECTRONICALLY CONTROLLED BLOWER MOTOR AND
VSP1
SEE SECTION VIII-NEW UNIT START-UP

CHECK:
1-UNIT POWER
2-INTERLOCK SWITCH
3-TRANSFORMER
4-TRANSFORMER FUSE
5-UNIT WIRING

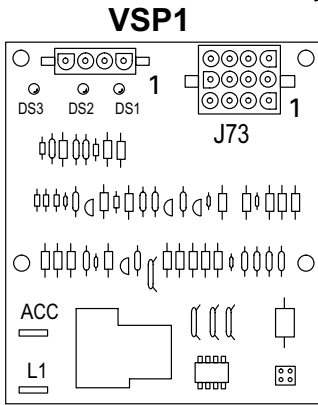

IS 24VAC ACROSS
PIN 8 AND 1
OF VSP1?

NO

PRIMARY LIMIT S10 IS NC
ALLOW UNIT TO COOL
IF LIMIT REMAINS OPEN
REPLACE LIMIT

IS 24VAC ACROSS J73
PIN 7 AND 1
OF VSP1?

NO

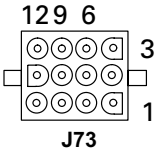

IS 24VAC ACROSS J73
PIN 3 AND 1
OF VSP1?

NO

REPLACE VSP1

IS 24VAC ACROSS R AND C ?

NO

CHECK WIRING BETWEEN TB1 AND VSP1
REPAIR IF NECESSARY

PLACE JUMPER ACROSS R AND W1.
WAIT 75 SECONDS FOR PREPURGE AND FAN-ON DELAY.

IS BLOWER ON LOW SPEED
AND IS DS1 LIT?

DS3 DS2 DS1

NO

BREAK AND RE-
MAKE
JUMPER (R TO W1).

IS 24VAC ACROSS
J73
PIN 11 AND 1
OF VSP1? NO → S78 IS A NC LIMIT
ALLOW UNIT TO COOL
IF LIMIT REMAINS
OPEN REPLACE
LIMIT

YES

IS 24VAC ACROSS J73
PIN 10 AND 1
OF VSP1? NO → REPLACE VSP1

YES

IF UNIT DOES NOT OPERATE
THE GAS VALVE OR IGNITION
CONTROL ARE NOT
OPERATING PROPERLY

CHECK UNIT WIRING FROM
VSP1 TO TB2 AND IF CORRECT,
REPLACE VSP1.

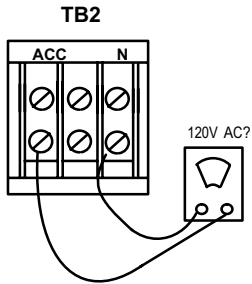

CHECK VOLTAGE ON TB2 FROM ACC TO N ON TERMINAL
BLOCK INSIDE CONTROL BOX-SHOULD READ "120" VOLTS AC

IS THE ACCESSORY
RELAY PULLED IN?

NO

YES

CONTINUED ON FOLLOWING PAGE

**“V” BLOWER AND VSP1 BLOWER CONTROL BOARD
HEATING MODE CHECKOUT (contd.)**

**HEATING MODE
(contd.)**

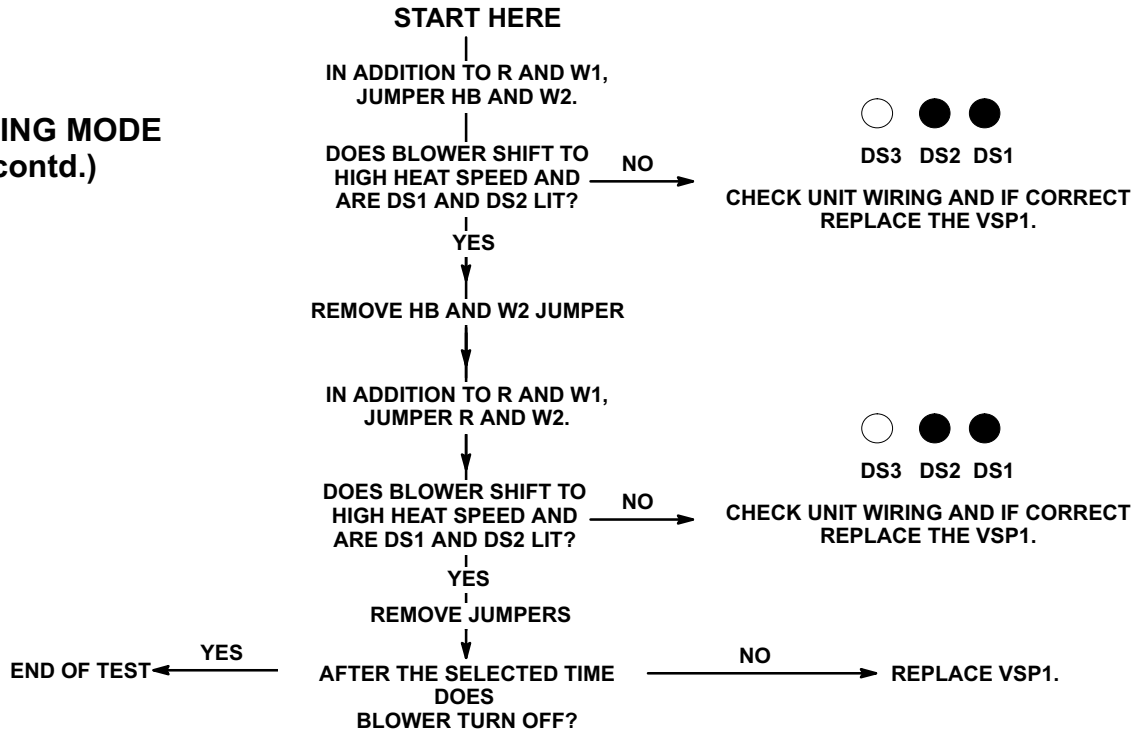

VSP1

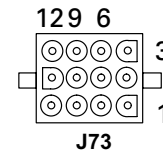
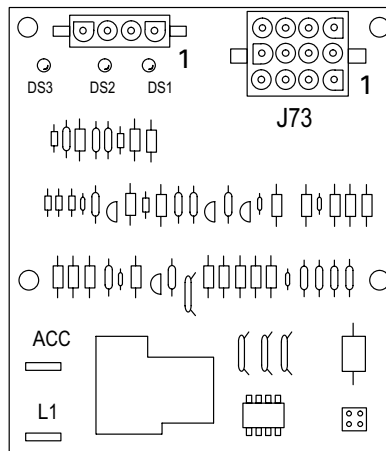

"V" BLOWER AND VSP1 BLOWER CONTROL BOARD COOLING MODE CHECKOUT

START HERE

DOES UNIT OPERATE?
 NO
 CHECK OUT ELECTRONICALLY CONTROLLED BLOWER MOTOR AND VSP1
 SEE SECTION VIII-NEW UNIT START-UP

IS 24VAC ACROSS J73
 PIN 8 AND 1
 OF VSP1?

CHECK:
 1-UNIT POWER
 2-INTERLOCK SWITCH
 3-TRANSFORMER
 4-TRANSFORMER FUSE
 5-UNIT WIRING

**START
 HERE**

IS 24VAC ACROSS J73
 PIN 7 AND 1
 OF VSP1?

NO — PRIMARY LIMIT S10 IS NC
 ALLOW UNIT TO COOL
 IF LIMIT REMAINS OPEN
 REPLACE LIMIT

IS 24VAC ACROSS J73
 PIN 3 AND 1
 OF VSP1?

NO — REPLACE VSP1

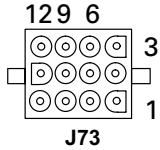

IS 24VAC ACROSS R AND C ?

NO — CHECK WIRING BETWEEN TB1 AND VSP1
 REPAIR IF NECESSARY

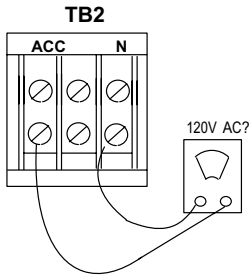

PLACE JUMPER ACROSS R AND G.

IS BLOWER ON LOW SPEED COOLING TAP
 AND IS DS1 LIT?

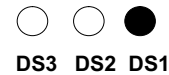

NO — CHECK UNIT WIRING AND IF CORRECT,
 REPLACE VSP1.

IS THE ACCESSORY
 RELAY PULLED IN?

NO — CHECK UNIT WIRING FROM VSP1 TO TB2
 AND IF CORRECT, REPLACE VSP1.

CHECK VOLTAGE ON TB2 FROM ACC TO N ON TERMINAL
 BLOCK INSIDE CONTROL BOX-SHOULD READ "120" VOLTS AC

IN ADDITION TO R AND G, JUMPER R AND DS.



END OF COOLING TEST

IS BLOWER ON HIGH
 SPEED COOLING TAP?
 ARE DS1 AND DS3
 LIT?

NO — CHECK UNIT WIRING AND IF CORRECT
 REPLACE THE VSP1.

⚠ WARNING

Disconnect thermostat wire to DS terminal before performing any test on this page.

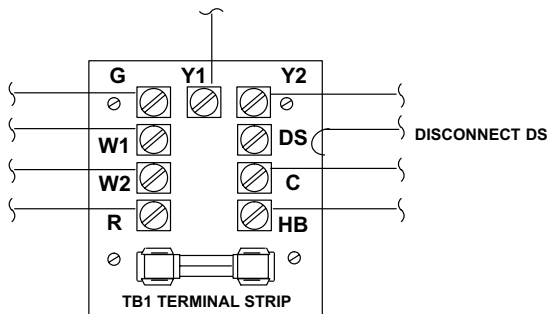

VSP1

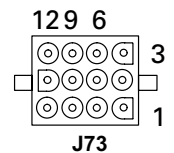
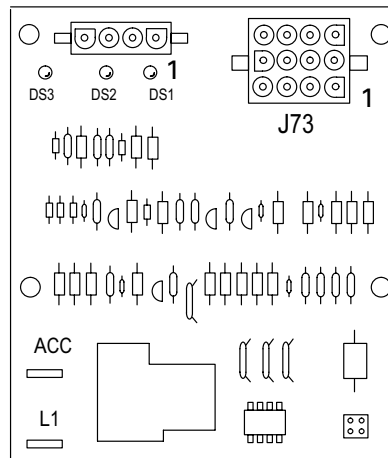

UNIT STARTS CLEAN BUT RUNS LESS THAN 10 SECONDS

START HERE

RESET UNIT IF LOCKED OUT, LISTEN FOR CHANGE IN SOUND OF UNIT BEFORE IT STOPS.

UNIT "LUGS" DOWN BEFORE STOPPING.

UNIT STOPS WITHOUT ANY CHANGE IN SOUND BEFORE STOPPING.

CHECK FOR RECIRCULATION OF EXHAUST GASES TO AIR INTAKE AT THE OUTSIDE TERMINATIONS OF PVC PIPING. ARE INTAKE AND EXHAUST PVC LINES SEPARATED NO MORE THAN 3" AT OUTSIDE TERMINATION? DOES EXHAUST TERMINATION EXTEND AT LEAST 8" PAST INTAKE TERMINATION?

RECIRCULATION CHECKS

NO → MODIFY OR CORRECT SEPARATION TO A MAXIMUM OF 3".

YES → ARE INTAKE AND EXHAUST PVC LINES TERMINATED INTO A WINDOW WELL, ALCOVE OR CORNER WHERE VARYING CONDITIONS CAUSE RECIRCULATION?

NO → IF OUTSIDE TEMPERATURE IS LOW ENOUGH, OBSERVE EXHAUST OUTLET VAPOR WHEN UNIT IS RUNNING. RECIRCULATION WILL EASILY BE SEEN. → MODIFY OR CORRECT TERMINATIONS TO ELIMINATE RECIRCULATION.

YES → MODIFY OR CORRECT TERMINATIONS TO ELIMINATE RECIRCULATION.

NOTE: RECIRCULATION IS ALSO POSSIBLE WHEN EXHAUST CO2 CONTENT IS ABOVE 10%. THIS IS DIFFICULT TO MEASURE AS AN INDICATION IN THIS CASE IF UNIT WILL ONLY RUN FOR 10 SECONDS OR LESS.

5

ARE LIMITS CUTTING OUT UNIT? CHECK FOR OPEN LIMIT IMMEDIATELY FOLLOWING UNIT CUT OUT. SHUT OFF POWER AND MAKE OHM METER CHECK.

NO → IS DIFFERENTIAL SWITCH CUTTING OUT UNIT?

YES → DETERMINE CAUSE OF LIMIT CUT OUT AND CORRECT PROBLEM.

4

MAKE OHM METER CHECK ACROSS TERMINALS IMMEDIATELY AFTER UNIT SHUTS OFF. METER READS ∞ OHMS WHEN SWITCH CUTS UNIT OUT.

IS DIFFERENTIAL SWITCH CUTTING OUT UNIT?

NO → IS FLAME SIGNAL PRESENT AND CORRECT? CHECK WITH MICROAMP METER.

YES → CHECK FOR PARTIAL BLOCKAGE OF ALL PVC PIPING & CONDENSATE LINE.

IF NO BLOCKAGE EXISTS REPLACE DIFFERENTIAL PRESSURE SWITCH.

IS FLAME SIGNAL PRESENT AND CORRECT? CHECK WITH MICROAMP METER.

CHECK SENSOR WIRE REPLACE IF DETERIORATED & RETEST UNIT

REMOVE & CHECK SPARK PLUG (USE LENNOX PART #20H43 OR 3/4" SPARK PLUG SOCKET).

1. WAS PLUG TIGHT WHEN REMOVED?
2. ARE CRACKS PRESENT IN PORCELAIN?
3. REPLACE SENSOR IF CRACKED?

MAKE RECIRCULATION CHECKS.

IF RECIRCULATION IS NOT PRESENT, CHECK FOR ADEQUATE GROUNDING OF UNIT AND PRIMARY CONTROL. IF OK, CHECK PRIMARY CONTROL TIMING.

MONITOR MANIFOLD PRESSURE OR GAS VALVE COIL, PURGE BLOWER (120 VAC), SPARK PLUG WIRE WITH SPARK TESTER AND FLAME SIGNAL. USE THE TIMING CHARTS (FIGURE NO. 10) TO DETERMINE IF THE CONTROL IS DEFECTIVE.

IF DEFECTIVE REPLACE PRIMARY CONTROL.

UNIT RUNS BUT SHUTS OFF BEFORE THERMOSTAT IS SATISFIED-INSUFFICIENT HEAT

START HERE

5

ARE LIMITS CUTTING OUT UNIT? CHECK FOR OPEN LIMIT IMMEDIATELY FOLLOWING UNIT CUTOFF. SHUT OFF POWER AND MAKE OHM METER CHECK.

MAKE OHM METER CHECK ACROSS TERMINALS IMMEDIATELY AFTER UNIT SHUTS OFF. METER READS OHMS WHEN SWITCH CUTS UNIT OUT.

IS GAS PRESSURE LOW? CHECK FOR INTERMITTENT LOW GAS PRESSURE. (MONITOR LOW GAS PRESSURE)

YES
CORRECT GAS PRESSURE.

NO
IS EXHAUST, INTAKE OR CONDENSATE PVC PIPING PARTIALLY BLOCKED OR RESTRICTED?

NO
YES
ELIMINATE BLOCKAGE AND RETEST.

IS FILTER CLEAN AND PROPERLY INSTALLED?
ARE SUPPLY AND RETURN AIR DUCTS UNRESTRICTED? CORRECT IF NECESSARY AND RETEST.

CHECK GAS BTUH INPUT.

IS INPUT HIGH? OUT OF ACCEPTABLE RANGE?

YES
NO

IS MANIFOLD PRESSURE TOO HIGH?

YES
NO
IS TEMPERATURE RISE AND STATIC PRESSURE WITHIN PROPER RANGE.

ADJUST GAS VALVE REGULATOR.

YES
NO
REPLACE LIMIT.
ADJUST BLOWER SPEED.

CHECK FOR RECIRCULATION OF EXHAUST GASES TO AIR INTAKE AT THE OUTSIDE TERMINATIONS OF PVC PIPING.

RECIRCULATION CHECKS

ARE INTAKE AND EXHAUST PVC LINES SEPARATED AT OUTSIDE TERMINATION? DOES EXHAUST TERMINATION EXTEND AT LEAST 8" PAST INTAKE TERMINATION?

NO
MODIFY OR CORRECT SEPARATION TO A MAXIMUM OF 3".

YES
ARE INTAKE AND EXHAUST PVC LINES TERMINATED INTO A WINDOW WELL, ALCOVE OR CORNER WHERE VARYING CONDITIONS CAUSE RECIRCULATION?

NO
IF OUTSIDE TEMPERATURE IS LOW ENOUGH, OBSERVE EXHAUST OUTLET VAPOR WHEN UNIT IS RUNNING. RECIRCULATION WILL EASILY BE SEEN.

YES
MODIFY OR CORRECT TERMINATIONS TO ELIMINATE RECIRCULATION.

MODIFY OR CORRECT TERMINATIONS TO ELIMINATE RECIRCULATION.

NOTE: RECIRCULATION IS ALSO POSSIBLE WHEN EXHAUST CO2 CONTENT IS ABOVE 10%. THIS IS DIFFICULT TO MEASURE AS AN INDICATION IN THIS CASE IF UNIT WILL ONLY RUN FOR 10 SECONDS OR LESS.

Typical **G21Q**
Diagram
 (-9 *model* **shown**)

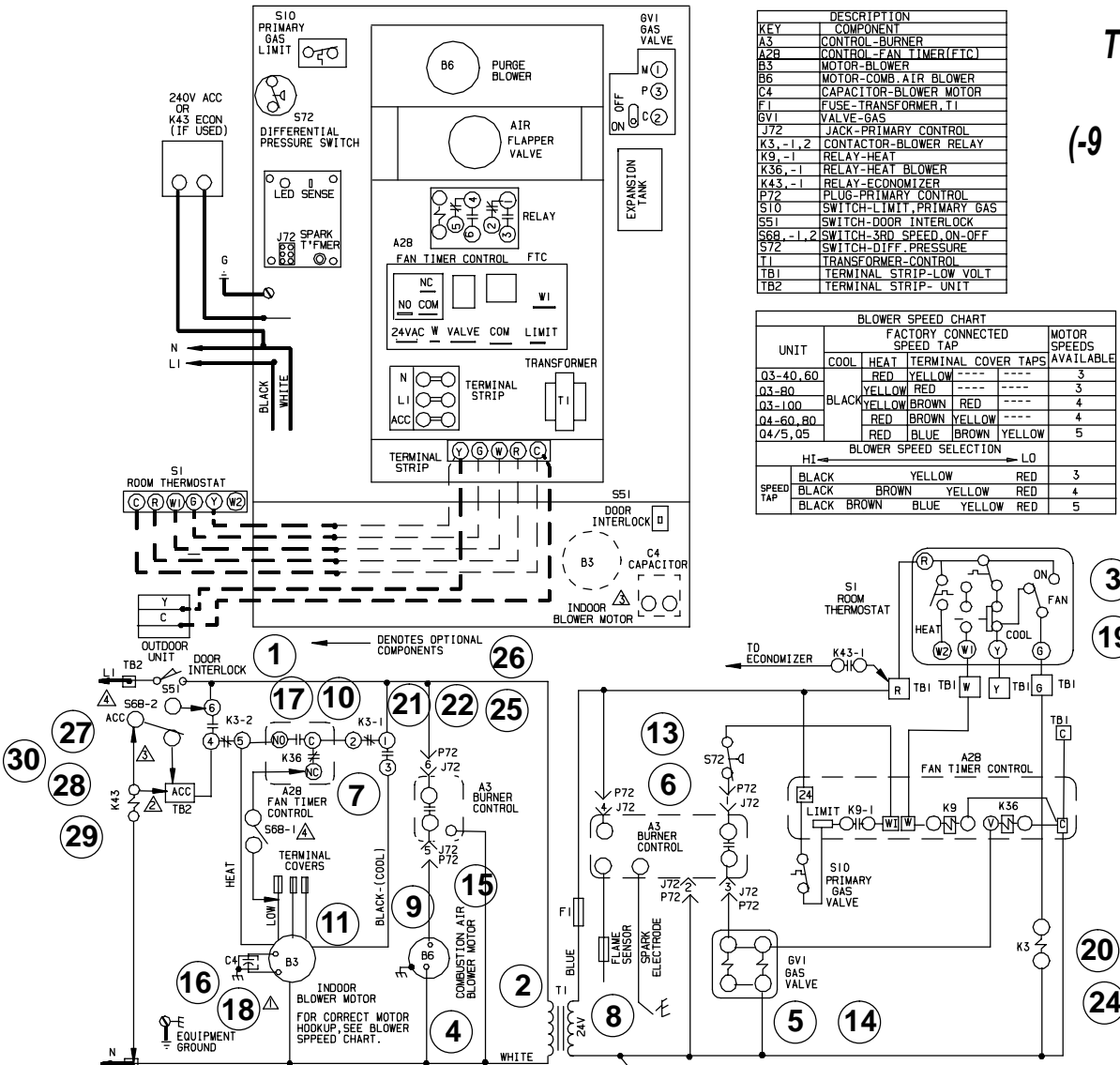

KEY COMPONENT	DESCRIPTION
A3	CONTROL-BURNER
A2B	CONTROL-FAN TIMER(FTC)
B3	MOTOR-BLOWER
B6	MOTOR-COMB. AIR BLOWER
C4	CAPACITOR-BLOWER MOTOR
F1	FUSE-TRANSFORMER, T1
GVI	VALVE-GAS
J72	JACK-PRIMARY CONTROL
K3, -1, 2	CONTACTOR-BLOWER RELAY
K9, -1	RELAY-HEAT
K36, -1	RELAY-HEAT BLOWER
K43, -1	RELAY-ECONOMIZER
P72	PLUG-PRIMARY CONTROL
S10	SWITCH-LIMIT, PRIMARY GAS
S51	SWITCH-DOOR INTERLOCK
S68, -1, 2	SWITCH-3RD SPEED, ON-OFF
S72	SWITCH-DIFF. PRESSURE
T1	TRANSFORMER-CONTROL
TB1	TERMINAL STRIP-LOW VOLT
TB2	TERMINAL STRIP- UNIT

UNIT	FACTORY CONNECTED SPEED TAP			MOTOR SPEEDS AVAILABLE		
	COOL	HEAT	TERMINAL COVER TAPS			
03-40, 60	RED	YELLOW	----	3		
03-80	BLACK	YELLOW	BROWN	3		
03-100	BLACK	BROWN	RED	4		
04-60, 80	RED	BROWN	YELLOW	4		
04/5, 05	RED	BLUE	BROWN YELLOW	5		
BLOWER SPEED SELECTION → LO						
HI ←						
SPEED TAP	BLACK	BROWN	YELLOW	RED	3	
	BLACK	BROWN	YELLOW	RED	4	
	BLACK	BROWN	BLUE	YELLOW	RED	5

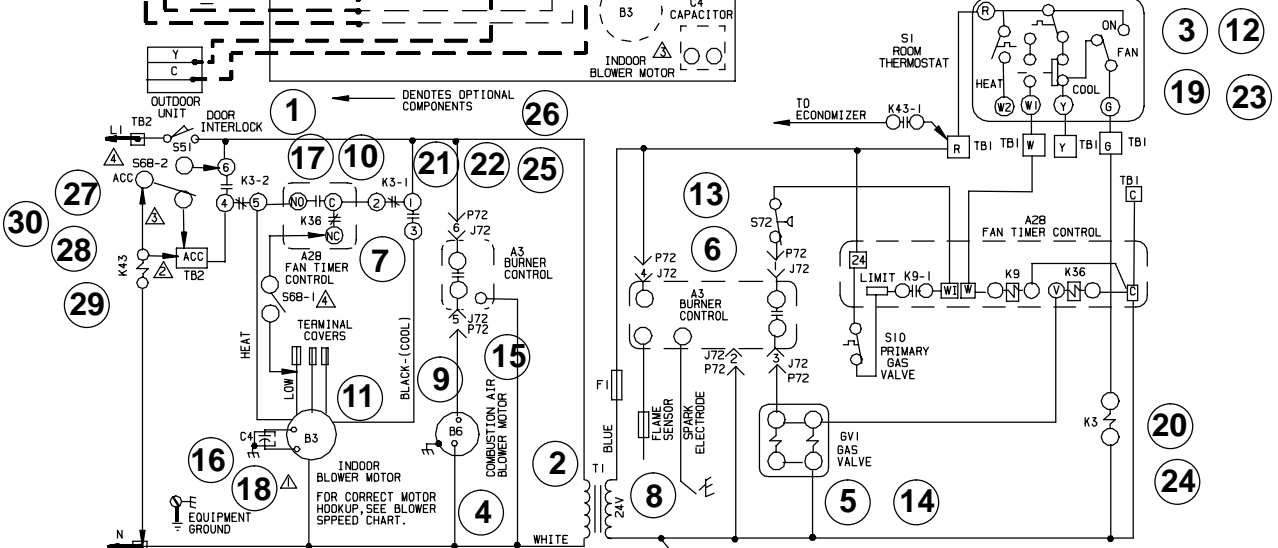

WARNING-
 ELECTRIC SHOCK HAZARD, CAN CAUSE INJURY OR DEATH. UNIT MUST BE GROUNDED IN ACCORDANCE WITH NATIONAL AND LOCAL CODES.

NOTE-
 IF ANY WIRE IN THIS APPLIANCE IS REPLACED, IT MUST BE REPLACED WITH WIRE OF LIKE SIZE, RATING AND INSULATION THICKNESS. IF RATING AND INSULATION ARE UNKNOWN, USE SAME SIZE THERMOPLASTIC 105 C WIRE WITH 5/64" INSULATION THICKNESS.

IMPORTANT-
 TO PREVENT MOTOR BURNOUT, NEVER CONNECT MORE THAN ONE MOTOR LEAD TO ANY ONE CONNECTION. TAPE ALL UNUSED MOTOR LEADS SEPARATELY.

- ⚠ IF S68 IS NOT USRD, CONNECT K43 TO TB2 ACC TERMINAL.
- ⚠ IF S68 IS USED, CONNECT K43 TO S68-2 COMMON TERMINAL.
- ⚠ S68 IS OPTIONAL SWITCH TO PROVIDE CONTINUOUS FAN OPERATION.

— LINE VOLTAGE FIELD INSTALLED
 - - - CLASS II VOLTAGE FIELD WIRING

LENNOX Industries Inc. WIRING DIAGRAM 9/98	
HEATING UNITS-GAS DSI	
62103-40, 60, 80-9	
62104-60, 80-9	62103-100-9
62105-80-9	62104/5-100-9
SECTION A	
Supersedes Form No.	New Form No.
	532, 895W
© 1998 Lennox Industries Inc. LITHO U.S.A.	

Sequence of Operation G21Q

A-EXPLANATION OF LENNOX' MODEL NUMBER DESIGNATIONS:

The following is an explanation of Lennox' model number designations:

G21Q: Residential unit with a up flow cabinet and a multi-speed blower motor.

G21V: Residential unit with a up flow cabinet and an electronically controlled blower motor.

GSR21Q: Residential unit with down flow/horizontal cabinet and a multi-speed blower motor.

GSR21V: Residential unit with a down flow/horizontal cabinet and an electronically controlled blower motor.

B-APPLICATION OF G21Q WITH GC3 IGNITION CONTROL

This flowchart is used to show the step by step sequence that takes place when thermostat demand is sent to a G21Q. The sequence describes the actions of devices in the unit which control blowers, fans, gas valve and other components in the system. The sequence is outlined by numbered steps which correspond to circled numbers on the adjacent diagram.

NOTE-This is a basic operation sequence for the G21Q. The thermostat shown is a basic electromechanical thermostat.

Operation Sequence:

- 1- Line voltage feeds through door interlock switch S51. The blower access panel must be in place to energize the unit.
- 2- Line voltage energizes transformer T1. Transformer T1 provides 24VAC power to all unit controls, terminal strip and thermostat.

Heating:

- 3- Heating demand initiates at W1 in the thermostat. The heating demand energizes K9 which closes N.O. K9-1. The heating demand then passes through the primary gas limit S10, heat relay K9-1 and differential pressure switch S72 enabling ignition control A3.
- 4- Combustion air blower B6 is energized for 30 ± 5 seconds by ignition control A3.
- 5- Gas valve opens and attempts for ignition occur.
- 6- Internal Watchguard is enabled only if ignition fails to light unit (5 tries). Watchguard will break and remake thermostat demand in 60 ± 5 minutes.
- 7- Fan timing control A28 is energized by gas valve GV1.
- 8- Spark stops .5 seconds after ignition is sensed or after 8.0 seconds if ignition is not sensed. (Early GC-3, in later versions and G891 spark for a full 8 seconds even if ignition is sensed).

9- Combustion air blower B6 is de-energized .5 seconds after ignition is sensed or after 8.0 seconds if ignition is not sensed. (Early GC-3, in later versions and G891 the combustion air blower B6 is de-energized after 8 seconds).

10-After the adjustable time of 30 - 60 seconds of successful ignition A28 energizes K36.

11-K36-1 N.O. closes energizing the blower B3 on heating speed and ACC terminal of TB2 is energized.

End of Heating Demand:

12- Heating demand is satisfied.

13- Ignition control A3 is de-energized.

14- Gas valve GV1 closes. Pulse cycle stops.

15- Combustion air blower B6 is energized for 30 ± 5 seconds post purge by ignition control A3.

16- A28 continues to power blower motor B3 for the adjustable time of 120-240 seconds.

17- After the adjustable delay, K36 is de-energized.

18- K36-1 closes de-energizing blower motor B3.

Blower Only:

19- Blower demand originates in the thermostat terminal G.

20- Blower contactor K3 is energized.

21- K3-1 N.O closes energizing blower (black tap).

22- K3-2 N.O. closes energizing ACC terminal on TB2 terminal strip.

Cooling Demand:

NOTE: Y TERMINAL ON LOW VOLTAGE TERMINAL STRIP IS USED FOR CONNECTING THERMOSTAT TO OUTDOOR UNIT (JUNCTION BLOCK). THE Y TERMINAL HAS NO INTERNAL CONNECTIONS TO THE UNIT.

23- Blower demand originates in the thermostat terminal G.

24- Blower contactor K3 is energized.

25- K3-1 N.O closes energizing blower on cooling speed (black tap).

26- K3-2 N.O. closes energizing accessories terminal on TB2 terminal strip.

Single-Stage or Two-Stage Cooling With CCB1 (EBR1 Required)

See Table 20 for operating characteristics.

Continuous Low Blower Kit-Optional

27- S68 is a DPST switch.

28- One pole (S68-1) is connected to the blower (low speed tap).

29- The other pole (S68-2) is connected to the ACC terminal of the TB2 terminal block.

30- When the switch is energized S68-1,2 both close energizing the blower on low speed and the ACC terminal. This assures a blower supply when optional accessories such as an electronic air cleaner operate.

TYPICAL GSR21Q DIAGRAM (-1 1 MODEL SHOWN)

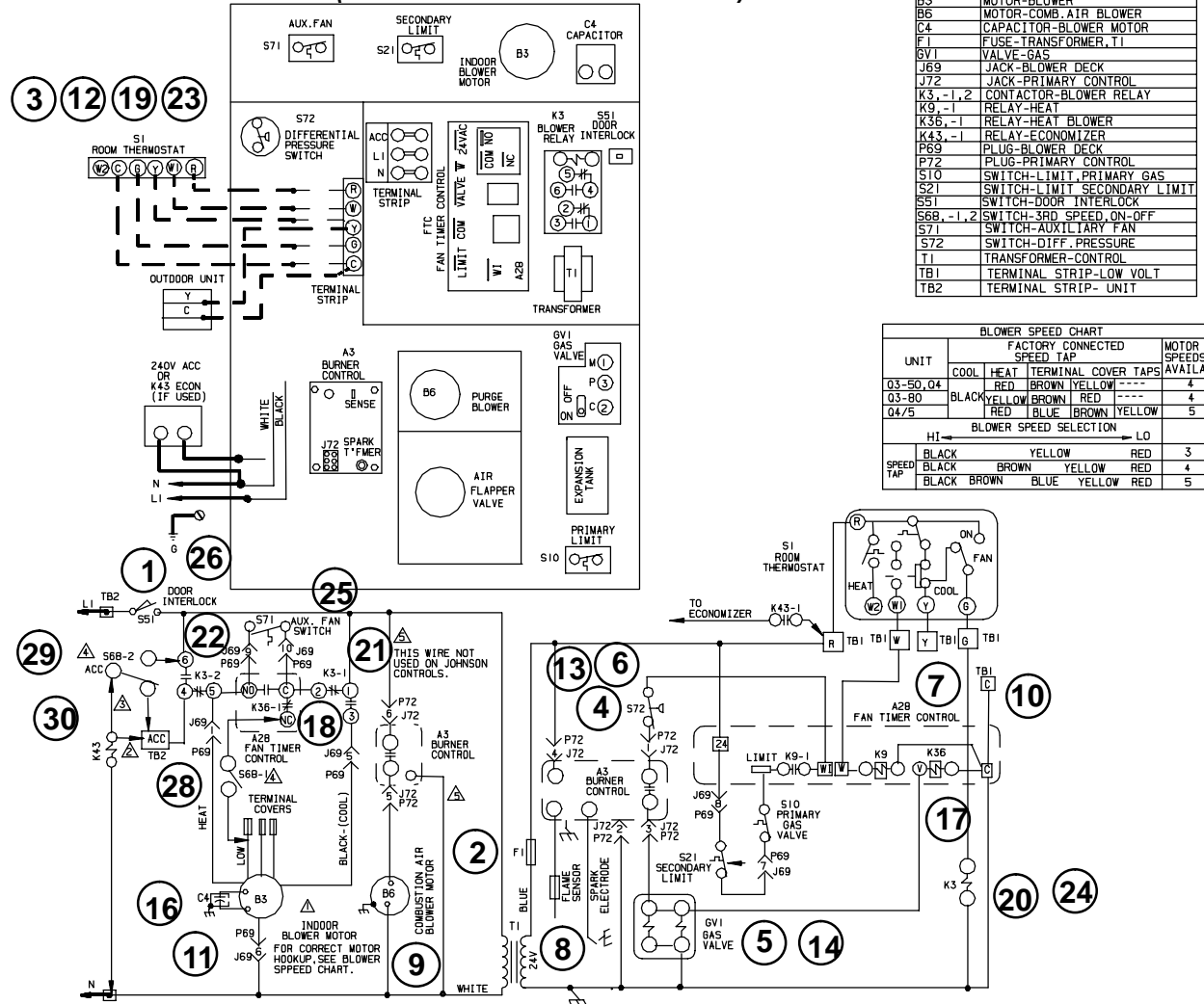

KEY	DESCRIPTION
A3	CONTROL - BURNER
A28	CONTROL - FAN - TIMER (FTC)
B3	MOTOR - BLOWER
B6	MOTOR - COMB. AIR BLOWER
C4	CAPACITOR - BLOWER MOTOR
F1	FUSE - TRANSFORMER, T1
GV1	VALVE - GAS
J69	JACK - BLOWER DECK
J72	JACK - PRIMARY CONTROL
K3 - 1, 2	CONTACTOR - BLOWER RELAY
K9 - 1	RELAY - HEAT
K36 - 1	RELAY - HEAT BLOWER
K43 - 1	RELAY - ECONOMIZER
P69	PLUG - BLOWER DECK
P72	PLUG - PRIMARY CONTROL
S10	SWITCH - LIMIT, PRIMARY GAS
S21	SWITCH - LIMIT, SECONDARY LIMIT
S51	SWITCH - DOOR INTERLOCK
S68 - 1, 2	SWITCH - 3RD SPEED ON-OFF
S71	SWITCH - AUXILIARY FAN
S72	SWITCH - DIFF. PRESSURE
T1	TRANSFORMER - CONTROL
TB1	TERMINAL STRIP - LOW VOLT
TB2	TERMINAL STRIP - UNIT

UNIT	BLOWER SPEED CHART				MOTOR SPEEDS AVAILABLE
	COOL	HEAT	TERMINAL COVER TAPS	FAN SPEED	
03-50, 04	RED	BROWN	YELLOW	----	4
03-80	BLACK	YELLOW	BROWN	RED	4
04/5	RED	BLUE	BROWN	YELLOW	5
BLOWER SPEED SELECTION					
HI ← → LO					
SPEED TAP	BLACK	BROWN	YELLOW	RED	3
	BLACK	BROWN	YELLOW	RED	4
	BLACK	BROWN	BLUE	YELLOW	5

WARNING - ELECTRIC SHOCK HAZARD, CAN CAUSE INJURY OR DEATH. UNIT MUST BE GROUNDED IN ACCORDANCE WITH NATIONAL AND LOCAL CODES.

NOTE - IF ANY WIRE IN THIS APPLIANCE IS REPLACED, IT MUST BE REPLACED WITH WIRE OF LIKE SIZE, RATING AND INSULATION THICKNESS. IF RATING AND INSULATION ARE UNKNOWN, USE SAME SIZE THERMOPLASTIC 105 °C WIRE WITH 5/64" INSULATION THICKNESS.

← DENOTES OPTIONAL COMPONENTS

IMPORTANT - TO PREVENT MOTOR BURNOUT, NEVER CONNECT MORE THAN ONE MOTOR LEAD TO ANY ONE CONNECTION. TAPE ALL UNUSED MOTOR LEADS SEPARATELY.

⚠ IF S68 IS NOT USED, CONNECT K43 TO TB2 ACC TERMINAL.

⚠ IF S68 IS USED, CONNECT K43 TO S68-2 COMMON TERMINAL.

⚠ S68 IS OPTIONAL SWITCH TO PROVIDE CONTINUOUS FAN OPERATION.

— LINE VOLTAGE FIELD INSTALLED
- - - CLASS II VOLTAGE FIELD WIRING

LENNOX Industrial Inc. WIRING DIAGRAM 9/98

HEATING UNITS-GAS OSI

GSR2103-50, 80-11
GSR2104-50-11
GSR2104/5-80, 100-11

SECTION A

Supersedes Form No. _____ New Form No. 532, 896W

©1998 Lennox Industries Inc. Litho U.S.A.

Sequence of Operation GSR21Q

C-APPLICATION OF GSR21Q WITH GC3 IGNITION CONTROL

This flowchart is used to show the step by step sequence that takes place when thermostat demand is sent to the GSR21Q. The sequence describes the actions of devices in the unit which control blowers, fans, gas valve and other components in the system. The sequence is outlined by numbered steps which correspond to circled numbers on the adjacent diagram.

NOTE - This is a basic operation sequence for the GSR21Q. The thermostat shown is a basic electromechanical thermostat.

Operation Sequence

- 1- Line voltage feeds through door interlock switch S51. The blower access panel must be in place to energize the unit.
- 2- Line voltage energizes transformer T1. Transformer T1 provides 24V AC power to all unit controls, terminal strip and thermostat.

Heating:

- 3- Heating demand initiates at W1 in the thermostat. The heating demand energizes K9 which closes N.O. K9-1. The heating demand then passes through the secondary gas limit S21, primary gas limit S10, heat relay K9-1 and differential pressure switch S72 enabling ignition control A3.
- 4- Combustion air blower B6 is energized for 30 ± 5 seconds by ignition control A3.
- 5- Gas valve opens and attempts for ignition occur.
- 6- Internal Watchguard is enabled only if ignition fails to light unit (5 tries). Watchguard will break and remake thermostat demand in 60 ± 5 minutes.
- 7- Fan timing control A28 is energized by gas valve GV1.
- 8- Spark stops .5 seconds after ignition is sensed or after 8.0 seconds if ignition is not sensed. (Early GC-3, in later versions and G891 spark for a full 8 seconds even if ignition is sensed).
- 9- Combustion air blower B6 is de-energized .5 seconds after ignition is sensed or after 8.0 seconds if ignition is not sensed. (Early GC-3, in later versions and G891 the combustion air blower B6 is de-energized after 8 seconds).
- 10-After the adjustable time of 30 - 60 seconds of successful ignition A28 energizes K36.
- 11-K36-1 N.O. closes energizing the blower B3 on heating speed and ACC terminal of TB2 is energized.

End of Heating Demand:

- 12-Heating demand is satisfied.
- 13-Ignition control A3 is de-energized.
- 14-Gas valve GV1 closes. Pulse cycle stops.
- 15-Combustion air blower B6 is energized for 30 ± 5 seconds post purge by ignition control A3.
- 16-A28 continues to power blower motor B3 for the adjustable time. 120-240 seconds.
- 17-After the adjustable delay, K36 is de-energized.
- 18-K36-1 closes de-energizing blower motor B3.

Blower Only:

- 19-Blower demand originates in the thermostat terminal G.
- 20-Blower contactor K3 is energized.
- 21-K3-1 N.O. closes energizing blower (black tap).
- 22-K3-2 N.O. closes energizing ACC terminal on TB2 terminal strip.

Cooling Demand:

NOTE: Y TERMINAL ON LOW VOLTAGE TERMINAL STRIP IS USED FOR CONNECTING THERMOSTAT TO OUTDOOR UNIT (JUNCTION BLOCK). THE Y TERMINAL HAS NO INTERNAL CONNECTIONS TO THE UNIT.

- 23-Blower demand originates in the thermostat terminal G.
- 24-Blower contactor K3 is energized.
- 25-K3-1 N.O. closes energizing blower on cooling speed (black tap).
- 26-K3-2 N.O. closes energizing accessories terminal on TB2 terminal strip.

Single-Stage or Two-Stage Cooling With CCB1 (EBR1 Required)

See Table 20 for operating characteristics.

Continuous Low Blower Kit-Optional

- 27-S68 is a DPST switch.
- 28-One pole (S68-1) is connected to the blower (low speed tap).
- 29-The other pole (S68-2) is connected to the ACC terminal of the TB2 terminal block.
- 30-When the switch is energized S68-1,2 both close energizing the blower on low speed and the ACC terminal. This assures a blower supply when optional accessories such as an electronic air cleaner operate.

Sequence of Operation G21V

D-OPERATION SEQUENCE G21V WITH GC3 IGNITION CONTROL

This flowchart is used to show the step by step sequence that takes place when thermostat demand is sent to the G21V. The sequence describes the actions of devices in the unit which control blowers, fans, gas valve and other components in the system. The sequence is outlined by numbered steps which correspond to circled numbers on the adjacent diagram.

NOTE- If a single stage thermostat is to be used, the heating blower jumpers should be in position # 1. This forces the blower to run on the high speed heat tap and stops frequent cycling which would occur. When the blower operates on the low speed heat/cool tap, reduced airflow causes heat exchanger temperatures to rise above the modulation control (S78) set point. The upper modulation limit will trip interrupting the W1 signal and energizing the blower. As the blower continues to run and the temperatures decrease, the lower modulation limit will trip resetting the W1 signal if there is still a call for heat.

If in a non-zoning application and no modulation of heat exchanger is desired, then the heat demand from the thermostat should be wired to terminal NM instead of W1.

NOTE- This is a basic operation sequence for the G21V. The thermostat shown is a basic electromechanical thermostat.

Operation Sequence

- 1- Line voltage feeds through door interlock switch S51. The blower access panel must be in place to energize the unit. (NOTE- Blower motor is always energized, S51 does not interrupt power to blower motor.)
- 2- Line voltage energizes transformer T1. Transformer T1 provides 24VAC power to all unit controls, terminal strip. Thermostat is energized after 24 VAC passes through normally closed primary limit S10.

Heating-Single Stage-Heating Blower jumper in position #2 (APPLICATIONS WITH A SINGLE-STAGE THERMOSTAT)

- 3- Heating demand initiates at W1 in the thermostat. Heating demand passes through modulation control switch S78 to terminal 11 of VSP2.
- 4- Terminal 10 of VSP2 energizes ignition control A3 passing through N.C. differential pressure switch S72.
- 5- Combustion air blower B6 is energized for 30 ± 5 seconds by ignition control A3.
- 6- Gas valve GV1 is energized by terminal 3 of ignition control A3.
- 7- Attempts for ignition occur. Internal Watchguard is enabled only if ignition fails to light unit (5 tries). Watchguard will break and remake thermostat demand in 60 ± 5 minutes.
- 8- Combustion air blower B6 and ignition control A3 are de-energized .5 seconds after ignition is sensed or after 8.0 seconds if ignition is not sensed. (Early GC-3, in later versions and G891 spark for a full 8 seconds even if ignition is sensed).
- 9- VSP2 internal circuitry starts blower on low speed heat/cool tap after a 45 second delay. After approximately 3-10 minutes heat exchanger temperatures will have risen to the set point of modulation control S78.
- 10- S78 will open, interrupting signal to VSP2 and in turn ignition control A3 is de-energized closing gas valve.
- 11- Combustion air blower B6 is energized for 30 ± 5 seconds by ignition control A3.
- 12- VSP2 internal circuitry forces blower to operate on low speed heat/cool tap, reducing heat exchanger temperature.
- 13- When heat exchanger temperature falls below the modulation control set point, modulation limit S78 closes and signal to VSP2 is remade. If there is still a call for heat, unit will attempt ignition and operate until S78 cycles again.

Heating-Single Stage - Heating Blower Jumper in Position #1 (APPLICATIONS WITH A SINGLE-STAGE THERMOSTAT)

- 14- The thermostat calls for heat (W1). Ignition is established. See steps 3-8.
- 15- Internal circuitry of the VSP2 forces the blower to run on high speed heat tap.

- 16- Heat exchanger temperatures are kept below modulation control S78 opening set point. Modulation control S78 is now acting as a safety limit.

Heating-Two Stage (APPLICATIONS WITH A TWO-STAGE THERMOSTAT / NM CAN NOT BE USED WITH TWO-STAGE) - Heating Blower jumper in position # 2

Stage One:

- 17- The thermostat calls for heat (W1). Ignition is established. See steps 3-9.
- 18- The unit operates in the first stage of heating. See steps 10-13.

Stage Two:

- 19- The thermostat calls for heat (W2). Ignition is established. See steps 3-9.
- 20- Pin 3 of VSP2 is energized. Internal circuitry of the VSP2 forces the blower to run on high speed heat tap.
- 21- Heat exchanger temperatures are kept below modulation control S78 opening set point.

Heating-Single Stage (NO MODULATION) - Heating Blower jumper in position # 1, W1 to NM

- 22- The thermostat calls for heat (W1 to NM). See steps 3-8.
- 23- Internal circuitry of the VSP2 forces the blower to run on high speed heat tap.

Heating-Single Stage (NO MODULATION) - Heating Blower jumper in position # 2, W1 to NM

- 24- The thermostat calls for heat (W1 to NM). See steps 3-8.
- 25- Internal circuitry of the VSP2 forces the blower to run on low speed (heat/cool) tap.

Heating-Zone Control System Used-Heating Blower jumper in position # 2 Stage One:

- 26- The thermostat calls for heat (W1). Ignition is established. See steps 3-9.
- 27- When the Harmony Zone Control System is used, the motor does not run at the low speed heat/cool or the high speed heating tap. Zone controller internal circuitry provides the DS terminal (Pin 4) to control blower speed based upon zone demands. Speed is determined by a PWM signal. Blower speed is based on the PWM signal determined by the number of zones calling.

End of Heating Demand:

- 28- Heating demand is satisfied. Ignition control A3 is de-energized. Gas valve GV1 closes. Pulse cycle stops.

- 29- Combustion air blower B6 is energized for 30 ± 5 seconds by ignition control A3.

- 30- VSP2 internal circuitry continues to power blower motor B3 on low speed heat/cool tap for the adjustable time 90-330 seconds. After the adjustable delay, B3 is de energized.

Blower Only:

- 31- Blower demand G originates in the thermostat. Terminal 2 of VSP2 is energized.
- 32- VSP2 internal circuitry forces blower to operate on low speed heat/cool tap.

Cooling-Single Stage-No CCB1, No Harmony, DS Jumpered to G (APPLICATIONS WITH A SINGLE-STAGE THERMOSTAT)

- 33- Refer to table 19 for operation characteristics.

Cooling-Two Stage-No CCB1, No Harmony, DS Jumpered to Y2 (APPLICATIONS WITH A TWO-STAGE THERMOSTAT)

Stage One:

- 34- Refer to table 19 for operation characteristics.

Stage Two:

- 35- Refer to table 19 for operation characteristics.

Cooling-CCB1 Used with Single-Speed or Two-Speed Compressor, No Harmony, No Jumpers

- 36- Refer to table 19 for operation characteristics.

Cooling-Harmony Zone Control Used With Single-Speed or Two-Speed Compressor, No CCB1, No Jumpers

- 37- Refer to table 19 for operation characteristics.

Sequence of Operation GSR21V

E-OPERATION SEQUENCE GSR21V WITH GC3 IGNITION CONTROL

This flowchart is used to show the step by step sequence that takes place when thermostat demand is sent to the GSR21V. The sequence describes the actions of devices in the unit which control blowers, fans, gas valve and other components in the system. The sequence is outlined by numbered steps which correspond to circled numbers on the adjacent diagram.

NOTE - If a single stage thermostat is to be used, the heating blower jumper should be in position # 1. This forces the blower to run on the high speed heat tap and stops frequent cycling which would occur. When the blower operates on the low speed heat/cool tap, reduced airflow causes heat exchanger temperatures to rise above the modulation control (S78) set point. The upper modulation limit will trip interrupting the W1 signal and energizing the blower. As the blower continues to run and the temperatures decrease, the lower modulation limit will trip resetting the W1 signal if there is still a call for heat.

If in a non-zoning application and no modulation of heat exchanger is desired, then the heat demand from the thermostat should be wired to terminal NM instead of W1.

NOTE - This is a basic operation sequence for the GSR21V. The thermostat shown is a basic electromechanical thermostat.

Operation Sequence

- 1- Line voltage feeds through door interlock switch S51. The blower access panel must be in place to energize the unit. (NOTE- Blower motor is always energized, S51 does not interrupt power to blower motor.)
- 2- Line voltage energizes transformer T1. Transformer T1 provides 24VAC power to all unit controls, terminal strip. Thermostat is energized after 24 VAC passes through normally closed primary limit S10.

Heating-Single Stage-Heating Blower jumper in position # 2 (APPLICATIONS WITH A SINGLE-STAGE THERMOSTAT)

- 3- Heating demand initiates at W1 in the thermostat. Heating demand passes through modulation control switch S78 to terminal 11 of VSP2.
- 4- Terminal 10 of VSP2 energizes ignition control A3 passing through N.C. differential pressure switch S72.
- 5- Combustion air blower B6 is energized for 30 ± 5 seconds by ignition control A3.
- 6- Gas valve GV1 is energized by terminal 3 of ignition control A3.
- 7- Attempts for ignition occur. Internal Watchguard is enabled only if ignition fails to light unit (5 tries). Watchguard will break and remake thermostat demand in 60 ± 5 minutes.
- 8- Combustion air blower B6 and ignition control A3 are de-energized .5 seconds after ignition is sensed or after 8.0 seconds if ignition is not sensed. (Early GC-3, in later versions and G891 spark for a full 8 seconds even if ignition is sensed)
- 9- VSP2 internal circuitry starts blower on low speed heat/cool tap after a 45 second delay. After approximately 3-10 minutes heat exchanger temperatures will have risen to the set point of modulation control S78.
- 10- S78 will open, interrupting signal to VSP2 and in turn ignition control A3 is de-energized closing gas valve.
- 11- Combustion air blower B6 is energized for 30 ± 5 seconds by ignition control A3.
- 12- VSP2 internal circuitry forces blower to operate on low speed heat/cool tap, reducing heat exchanger temperature.
- 13- When heat exchanger temperature falls below the modulation control set point, modulation limit S78 closes and signal to VSP2 is remade. If there is still a call for heat, unit will attempt ignition and operate until S78 cycles again.

Heating-Single Stage - Heating Blower jumper in position # 1 (APPLICATIONS WITH A SINGLE-STAGE THERMOSTAT)

- 14- The thermostat calls for heat (W1). Ignition is established. See steps 3-8.
- 15- Internal circuitry of the VSP2 forces the blower to run on high speed heat tap.
- 16- Heat exchanger temperatures are kept below modulation control S78 opening set point. Modulation control S78 is now acting as a safety limit.

Heating-Two Stage (APPLICATIONS WITH A TWO-STAGE THERMOSTAT / NM CAN NOT BE USED WITH TWO-STAGE) - Heating Blower jumper in position # 2.

Stage One:

- 17- The thermostat calls for heat (W1). Ignition is established. See steps 3-9.
- 18- The unit operates in the first stage of heating. See steps 10-13.

Stage Two:

- 19- The thermostat calls for heat (W2). Ignition is established. See steps 3-9.
- 20- Pin 3 of VSP2 is energized. Internal circuitry of the VSP2 forces the blower to run on high speed heat tap.
- 21- Heat exchanger temperatures are kept below modulation control S78 opening set point.

Heating-Single Stage (NO MODULATION) - Heating Blower jumper in position # 1, W1 to NM

- 22- The thermostat calls for heat (W1 to NM). See steps 3-8.
- 23- Internal circuitry of the VSP2 forces the blower to run on high speed heat tap.

Heating-Single Stage (NO MODULATION) - Heating Blower jumper in position # 2, W1 to NM

- 24- The thermostat calls for heat (W1 to NM). See steps 3-8.
- 25- Internal circuitry of the VSP2 forces the blower to run on low speed (heat/cool) tap.

Heating-Zone Control System Used-Heating Blower jumper in position # 2.

Stage One:

- 26- The thermostat calls for heat (W1). Ignition is established. See steps 3-9.
- 27- When the Harmony Zone Control System is used, the motor does not run at the low speed heat/cool or the high speed heating tap. Zone controller internal circuitry provides the DS terminal (Pin 4) to control blower speed based upon zone demands. Speed is determined by a PWM signal. Blower speed is based on the PWM signal determined by the number of zones calling.

End of Heating Demand:

- 28- Heating demand is satisfied. Ignition control A3 is de-energized. Gas valve GV1 closes. Pulse cycle stops.
- 29- Combustion air blower B6 is energized for 30 ± 5 seconds by ignition control A3.
- 30- VSP2 internal circuitry continues to power blower motor B3 on low speed heat/cool tap for the adjustable time 90-330 seconds. After the adjustable delay, B3 is de energized.

Blower Only:

- 31- Blower demand G originates in the thermostat. Terminal 2 of VSP2 is energized.
- 32- VSP2 internal circuitry forces blower to operate on low speed heat/cool tap.

Cooling-Single Stage-No CCB1, No Harmony, DS Jumpered to G (APPLICATIONS WITH A SINGLE-STAGE THERMOSTAT)

- 33- Refer to table 19 for operation characteristics.

Cooling-Two Stage-No CCB1, No Harmony, DS Jumpered to Y2 (APPLICATIONS WITH A TWO-STAGE THERMOSTAT)

Stage One:

- 34- Refer to table 19 for operation characteristics.

Stage Two:

- 35- Refer to table 19 for operation characteristics.

Cooling-CCB1 Used with Single-Speed or Two-Speed Compressor, No Harmony, No Jumpers

- 36- Refer to table 19 for operation characteristics.

Cooling-Harmony Zone Control Used With Single-Speed or Two-Speed Compressor, No CCB1, No Jumpers

- 37- Refer to table 19 for operation characteristics.

G21Q with GC3 Ignition Control

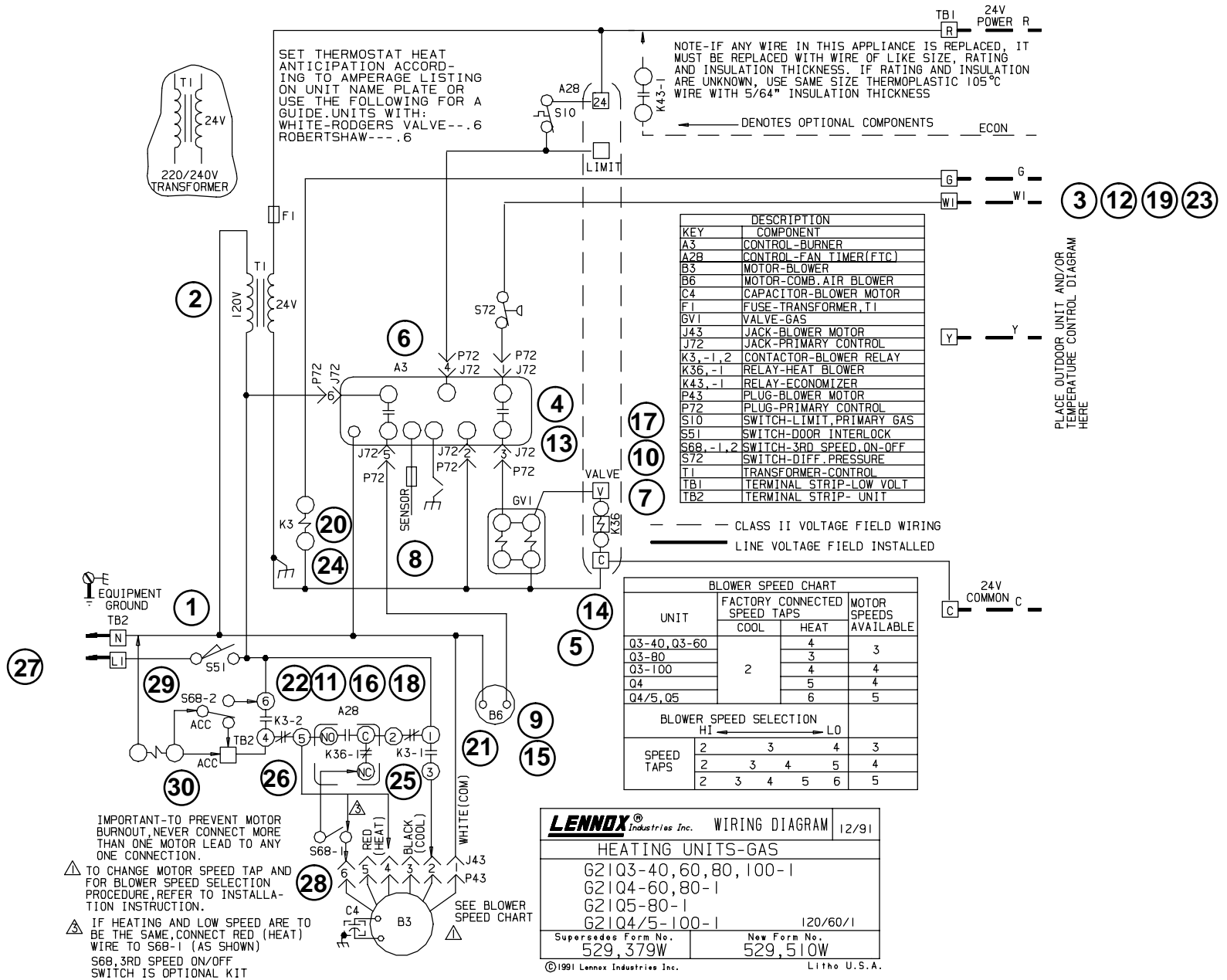

Sequence of Operation G21Q with GC3 Ignition Control

F-EXPLANATION OF LENNOX' MODEL NUMBER DESIGNATIONS:

The following is an explanation of Lennox' model number designations:

G21Q: Residential unit with a up flow cabinet and a multi-speed blower motor.

G21V: Residential unit with a up flow cabinet and an electronically controlled blower motor.

GSR21Q: Residential unit with down flow/horizontal cabinet and a multi-speed blower motor.

GSR21V: Residential unit with a down flow/horizontal cabinet and an electronically controlled blower motor.

G-APPLICATION OF G21Q WITH GC3 IGNITION CONTROL

This flowchart is used to show the step by step sequence that takes place when thermostat demand is sent to a G21Q. The sequence describes the actions of devices in the unit which control blowers, fans, gas valve and other components in the system. The sequence is outlined by numbered steps which correspond to circled numbers on the adjacent diagram.

NOTE-This is a basic operation sequence for the G21Q. The thermostat shown is a basic electromechanical thermostat.

Operation Sequence:

- 1- Line voltage feeds through door interlock switch S51. The blower access panel must be in place to energize the unit.
- 2- Line voltage energizes transformer T1. Transformer T1 provides 24VAC power to all unit controls, terminal strip and thermostat.

Heating:

- 3- Heating demand initiates at W1 in the thermostat. Heating demand passes through primary gas limit S10 through the differential pressure switch S72 enabling ignition control A3.
- 4- Combustion air blower B6 is energized for 30 ± 5 seconds by ignition control A3.
- 5- Gas valve opens and attempts for ignition occur.
- 6- Internal Watchguard is enabled only if ignition fails to light unit (5 tries). Watchguard will break and remake thermostat demand in 60 ± 5 minutes.
- 7- Fan timing control A28 is energized by gas valve GV1.
- 8- Spark stops .5 seconds after ignition is sensed or after 8.0 seconds if ignition is not sensed.
- 9- Combustion air blower B6 is de-energized .5 seconds after ignition is sensed or after 8.0 seconds if ignition is not sensed.

10- After 45 seconds of successful ignition A28 energizes K36.

11- K36-1 N.O. closes energizing the blower B3 on heating speed and ACC terminal of TB2 is energized.

End of Heating Demand:

12- Heating demand is satisfied.

13- Ignition control A3 is de-energized.

14- Gas valve GV1 closes. Pulse cycle stops.

15- Combustion air blower B6 is energized for 30 ± 5 seconds post purge by ignition control A3.

16- A28 continues to power blower motor B3 for the adjustable time of 120-240 seconds.

17- After the adjustable delay, K36 is de energized.

18- K36-1 closes de-energizing blower motor B3.

Blower Only:

19- Blower demand originates in the thermostat terminal G.

20- Blower contactor K3 is energized.

21- K3-1 N.O closes energizing blower (black tap).

22- K3-2 N.O. closes energizing ACC terminal on TB2 terminal strip.

Cooling Demand:

NOTE: Y TERMINAL ON LOW VOLTAGE TERMINAL STRIP IS USED FOR CONNECTING THERMOSTAT TO OUTDOOR UNIT (JUNCTION BLOCK). THE Y TERMINAL HAS NO INTERNAL CONNECTIONS TO THE UNIT.

23- Blower demand originates in the thermostat terminal G.

24- Blower contactor K3 is energized.

25- K3-1 N.O closes energizing blower on cooling speed (black tap).

26- K3-2 N.O. closes energizing accessories terminal on TB2 terminal strip.

Single-Stage or Two-Stage Cooling With CCB1 (EBR1 Required)

See Table20 for operating characteristics.

Continuous Low Blower Kit-Optional

27- S68 is a DPST switch.

28- One pole (S68-1) is connected to the blower (low speed tap).

29- The other pole (S68-2) is connected to the ACC terminal of the TB2 terminal block.

30- When the switch is energized S68-1,2 both close energizing the blower on low speed and the ACC terminal. This assures a blower supply when optional accessories such as an electronic air cleaner operate.

G21Q with GC1 Ignition Control

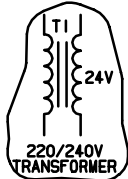

SET THERMOSTAT HEAT ANTICIPATION ACCORDING TO AMPERAGE LISTING ON UNIT NAME PLATE OR USE THE FOLLOWING FOR A GUIDE. UNITS WITH: WHITE-ROGERS VALVE---.6 ROBERTSHAW---.8

NOTE-IF ANY WIRE IN THIS APPLIANCE IS REPLACED, IT MUST BE REPLACED WITH WIRE OF LIKE SIZE, RATING AND INSULATION THICKNESS. IF RATING AND INSULATION ARE UNKNOWN, USE SAME SIZE THERMOPLASTIC 105°C WIRE WITH 5/64" INSULATION THICKNESS

--- CLASS II VOLTAGE FIELD WIRING
 --- LINE VOLTAGE FIELD INSTALLED

⚠ TERMINAL Ⓢ MAY NOT BE PROVIDED ON ALL THERMOSTATS

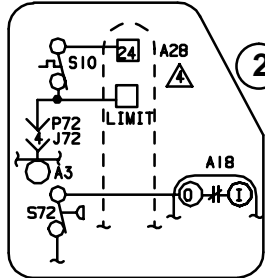

RE-WIRE S10, S72 AND A3 AS SHOWN. THIS NEW WIRING SEQUENCE WILL ENABLE THE INDOOR BLOWER MOTOR (B3) TO ENERGIZE IF THE PRIMARY LIMIT SWITCH (S10) OPENS.

NOTE-REMOVE JUMPER BETWEEN TERMINALS 24 & LIMIT ON A28 CONTROL.

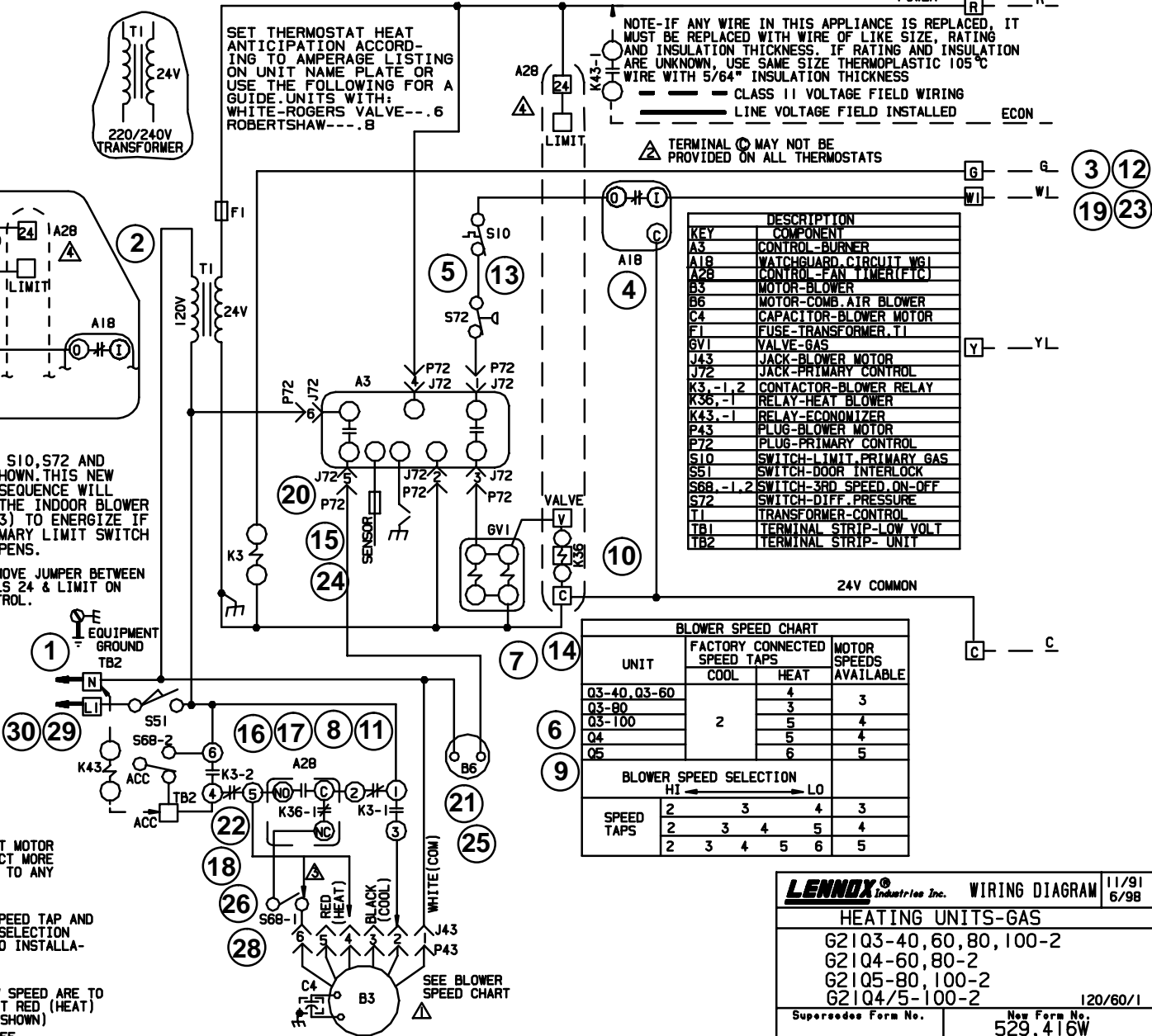

KEY	DESCRIPTION
A3	CONTROL-BURNER
A18	WATCHGUARD CIRCUIT WG1
A28	CONTROL-FAN TIMER(ETC)
B3	MOTOR-BLOWER
B6	MOTOR-COMB AIR BLOWER
C4	CAPACITOR-BLOWER MOTOR
F1	FUSE-TRANSFORMER T1
6V1	VALVE-GAS
J43	JACK-BLOWER MOTOR
J72	JACK-PRIMARY CONTROL
K3-1,2	CONTACTOR-BLOWER RELAY
K36-1	RELAY-HEAT BLOWER
K43-1	RELAY-ECONOMIZER
P43	PLUG-BLOWER MOTOR
P72	PLUG-PRIMARY CONTROL
S10	SWITCH-LIMIT, PRIMARY GAS
S51	SWITCH-DOOR INTERLOCK
S68-1,2	SWITCH-3RD SPEED ON-OFF
S72	SWITCH-DIFF. PRESSURE
T1	TRANSFORMER-CONTROL
TB1	TERMINAL STRIP-LOW VOLT
TB2	TERMINAL STRIP- UNIT

UNIT	FACTORY CONNECTED SPEED TAPS		MOTOR SPEEDS AVAILABLE
	COOL	HEAT	
Q3-40, Q3-60		4	
Q3-80		3	3
Q3-100	2	5	4
Q4		5	4
Q5		6	5

BLOWER SPEED SELECTION					
HI ← → LO					
SPEED TAPS	2	3	4	3	
	2	3	4	5	4
	2	3	4	5	6

IMPORTANT-TO PREVENT MOTOR BURNOUT, NEVER CONNECT MORE THAN ONE MOTOR LEAD TO ANY ONE CONNECTION.

⚠ TO CHANGE MOTOR SPEED TAP AND FOR BLOWER SPEED SELECTION PROCEDURE, REFER TO INSTALLATION INSTRUCTION.

⚠ IF HEATING AND LOW SPEED ARE TO BE THE SAME, CONNECT RED (HEAT) WIRE TO S68-1 (AS SHOWN) S68, 3RD SPEED ON/OFF SWITCH IS OPTIONAL KIT

LENNOX Industries Inc. WIRING DIAGRAM 11/91 6/98

HEATING UNITS-GAS

G21Q3-40, 60, 80, 100-2
 G21Q4-60, 80-2
 G21Q5-80, 100-2
 G21Q4/5-100-2 120/60/1

Supersedes Form No. _____ New Form No. 529,416W

Sequence of Operation G21Q with GC1 Ignition Control

H-APPLICATION OF G21Q WITH GC1 IGNITION CONTROL

This flowchart is used to show the step by step sequence that takes place when thermostat demand is sent to a G21Q. The sequence describes the actions of devices in the unit which control blowers, fans, gas valve and other components in the system. The sequence is outlined by numbered steps which correspond to circled numbers on the adjacent diagram.

NOTE-This is a basic operation sequence for the G21Q. The thermostat shown is a basic electromechanical thermostat.

Operation Sequence:

- 1- Line voltage feeds through door interlock switch S51. The blower access panel must be in place to energize the unit.
- 2- Line voltage energizes transformer T1. Transformer T1 provides 24VAC power to all unit controls, terminal strip and thermostat.

Heating:

- 3- Heating demand initiates at W1 in the thermostat.
- 4- Heating demand passes through the normally closed contacts of the external Watchguard. Watchguard is enabled. The Watchguard will break and remake thermostat demand in 60 ± 5 minutes.
- 5- Heating demand continues through primary gas limit S10 through the differential pressure switch S72 enabling ignition control A3.
- 6- Combustion air blower B6 is energized for 30 ± 2 seconds by ignition control A3.
- 7- Gas valve opens and attempts for ignition occur.
- 8- Fan timing control A28 is energized by gas valve GV1.
- 9- After ignition is sensed, GC1 continues sparking and the combustion air blower is energized for the remaining time of the ignition attempt.
- 10- After 45 seconds of successful ignition A28 energizes K36.
- 11- K36-1 N.O. closes energizing the blower B3 on heating speed and ACC terminal of TB2 is energized.

End of Heating Demand:

- 12- Heating demand is satisfied.

- 13- Ignition control A3 is de-energized.

- 14- Gas valve GV1 closes. Pulse cycle stops.

- 15- Combustion air blower is energized for 30 ± 2 seconds post purge by ignition control A3.

- 16- A28 continues to power blower motor B3 for the adjustable time. 120-240 seconds.

- 17- After the adjustable delay, K36 is de-energized.

- 18- K36-1 closes de-energizing blower motor B3.

Blower Only:

- 19- Blower demand originates in the thermostat terminal G.

- 20- Blower contactor K3 is energized.

- 21- K3-1 N.O. closes energizing blower (black tap).

- 22- K3-2 N.O. closes energizing ACC terminal on TB2 terminal strip.

Cooling Demand:

NOTE: Y TERMINAL ON LOW VOLTAGE TERMINAL STRIP IS USED FOR CONNECTING THERMOSTAT TO OUTDOOR UNIT (JUNCTION BLOCK). THE Y TERMINAL HAS NO INTERNAL CONNECTIONS TO THE UNIT.

- 23- Blower demand originates in the thermostat terminal G.

- 24- Blower contactor K3 is energized.

- 25- K3-1 N.O. closes energizing blower on cooling speed (black tap).

- 26- K3-2 N.O. closes energizing accessories terminal on TB2 terminal strip.

Single-Stage or Two-Stage Cooling With CCB1 (EBR1 Required)

See Table 20 for operating characteristics.

Continuous Low Blower Kit-Optional

- 27- S68 is a DPST switch.

- 28- One pole (S68-1) is connected to the blower (low speed tap).

- 29- The other pole (S68-2) is connected to the ACC terminal of the TB2 terminal block.

- 30- When the switch is energized S68-1,2 both close energizing the blower on low speed and the ACC terminal. This assures a blower supply when optional accessories such as an electronic air cleaner operate.

GSR21Q with GC3 Ignition Control

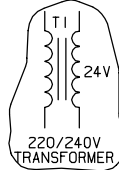

SET THERMOSTAT HEAT ANTICIPATION ACCORDING TO AMPERAGE LISTING ON UNIT NAME PLATE OR USE THE FOLLOWING FOR A GUIDE. UNITS WITH: WHITE-RODGERS VALVE---.6 ROBERTSHAW---.6

△ S21 IS AUTO RESET ON -3 UNITS ONLY

NOTE-IF ANY WIRE IN THIS APPLIANCE IS REPLACED, IT MUST BE REPLACED WITH WIRE OF LIKE SIZE, RATING AND INSULATION THICKNESS. IF RATING AND INSULATION ARE UNKNOWN, USE SAME SIZE THERMOPLASTIC 105°C WIRE WITH 5/64" INSULATION THICKNESS

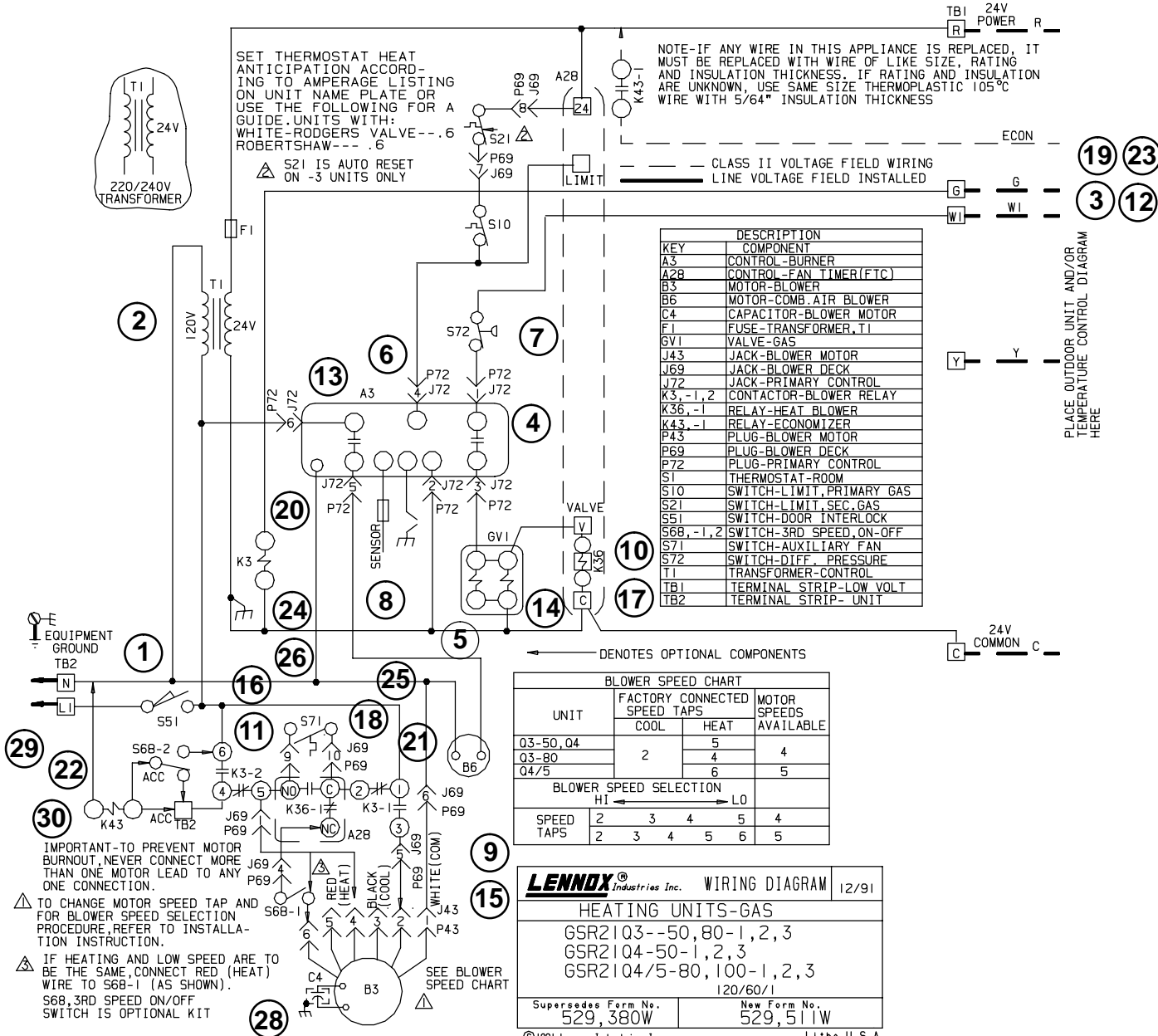

KEY	DESCRIPTION
A3	CONTROL - BURNER
A2B	CONTROL - FAN TIMER (FTC)
B3	MOTOR - BLOWER
B6	MOTOR - COMB. AIR BLOWER
C4	CAPACITOR - BLOWER MOTOR
F1	FUSE - TRANSFORMER, T1
GV1	VALVE - GAS
J43	JACK - BLOWER MOTOR
J69	JACK - BLOWER DECK
J72	JACK - PRIMARY CONTROL
K3, -1, 2	CONTACTOR - BLOWER RELAY
K36, -1	RELAY - HEAT BLOWER
K43, -1	RELAY - ECONOMIZER
P43	PLUG - BLOWER MOTOR
P69	PLUG - BLOWER DECK
P72	PLUG - PRIMARY CONTROL
S1	THERMOSTAT - ROOM
S10	SWITCH - LIMIT, PRIMARY GAS
S21	SWITCH - LIMIT, SEC. GAS
S51	SWITCH - DOOR INTERLOCK
S68, -1, 2	SWITCH - 3RD SPEED, ON-OFF
S71	SWITCH - AUXILIARY FAN
S72	SWITCH - DIFF. PRESSURE
T1	TRANSFORMER - CONTROL
TB1	TERMINAL STRIP - LOW VOLT
TB2	TERMINAL STRIP - UNIT

19 23
3 12
Y Y
C C
PLACE OUTDOOR UNIT AND/OR TEMPERATURE CONTROL DIAGRAM HERE

← DENOTES OPTIONAL COMPONENTS

UNIT	FACTORY CONNECTED SPEED TAPS		MOTOR SPEEDS AVAILABLE
	COOL	HEAT	
Q3-50, Q4	2	5	4
Q3-80		4	
Q4/5		6	

SPEED TAPS	HI ← → LO					
	2	3	4	5	4	
	2	3	4	5	6	5

IMPORTANT-TO PREVENT MOTOR BURNOUT, NEVER CONNECT MORE THAN ONE MOTOR LEAD TO ANY ONE CONNECTION.

△ TO CHANGE MOTOR SPEED TAP AND FOR BLOWER SPEED SELECTION PROCEDURE, REFER TO INSTALLATION INSTRUCTION.

△ IF HEATING AND LOW SPEED ARE TO BE THE SAME, CONNECT RED (HEAT) WIRE TO S68-1 (AS SHOWN). S68, 3RD SPEED ON/OFF SWITCH IS OPTIONAL KIT

LENNOX Industries Inc. WIRING DIAGRAM 12/91

HEATING UNITS-GAS

GSR21Q3--50, 80-1, 2, 3
GSR21Q4-50-1, 2, 3
GSR21Q4/5-80, 100-1, 2, 3
120/60/1

Supersedes Form No. 529, 380W	New Form No. 529, 511W
-------------------------------	------------------------

©1991 Lennox Industries Inc. Litho U.S.A.

Sequence of Operation GSR21Q with GC3 Ignition Control

I-APPLICATION OF GSR21Q WITH GC3 IGNITION CONTROL

This flowchart is used to show the step by step sequence that takes place when thermostat demand is sent to the GSR21Q. The sequence describes the actions of devices in the unit which control blowers, fans, gas valve and other components in the system. The sequence is outlined by numbered steps which correspond to circled numbers on the adjacent diagram.

NOTE- This is basic operation sequence for the GSR21Q. The thermostat shown is a basic electromechanical thermostat.

Operation Sequence

- 1- Line voltage feeds through door interlock switch S51. The blower access panel must be in place to energize the unit.
- 2- Line voltage energizes transformer T1. Transformer T1 provides 24VAC power to all unit controls, terminal strip and thermostat.

Heating:

- 3- Heating demand initiates at W1 in the thermostat. Heating demand passes through secondary gas limit S21 to primary gas limit S10 through the differential pressure switch S72 enabling ignition control A3.
- 4- Combustion air blower B6 is energized for 30 ± 5 seconds by ignition control A3.
- 5- Gas valve opens and attempts for ignition occur.
- 6- Internal Watchguard is enabled only if ignition fails to light unit (5 tries). Watchguard will break and remake thermostat demand in 60 ± 5 minutes.
- 7- Fan timing control A28 is energized by gas valve GV1.
- 8- Spark stops .5 seconds after ignition is sensed or after 8.0 seconds if ignition is not sensed.
- 9- Combustion air blower B6 is de-energized .5 seconds after ignition is sensed or after 8.0 seconds if ignition is not sensed.
- 10- After 45 seconds of successful ignition A28 energizes K36.
- 11- K36-1 N.O. closes energizing the blower B3 on heating speed and ACC terminal of TB2 is energized.

End of Heating Demand:

- 12- Heating demand is satisfied.

- 13- Ignition control A3 is de-energized.

- 14- Gas valve GV1 closes. Pulse cycle stops.

- 15- Combustion air blower B6 is energized for 30 ± 5 seconds post purge by ignition control A3.

- 16- A28 continues to power blower motor B3 for the adjustable time. 120-240 seconds.

- 17- After the adjustable delay, K36 is de-energized.

- 18- K36-1 closes de-energizing blower motor B3.

Blower Only:

- 19- Blower demand originates in the thermostat terminal G.

- 20- Blower contactor K3 is energized.

- 21- K3-1 N.O. closes energizing blower (black tap).

- 22- K3-2 N.O. closes energizing ACC terminal on TB2 terminal strip.

Cooling Demand:

NOTE: Y TERMINAL ON LOW VOLTAGE TERMINAL STRIP IS USED FOR CONNECTING THERMOSTAT TO OUTDOOR UNIT (JUNCTION BLOCK). THE Y TERMINAL HAS NO INTERNAL CONNECTIONS TO THE UNIT.

- 23- Blower demand originates in the thermostat terminal G.

- 24- Blower contactor K3 is energized.

- 25- K3-1 N.O. closes energizing blower on cooling speed (black tap).

- 26- K3-2 N.O. closes energizing accessories terminal on TB2 terminal strip.

Single-Stage or Two-Stage Cooling With CCB1 (EBR1 Required)

See Table 20 for operating characteristics.

Continuous Low Blower Kit-Optional

- 27- S68 is a DPST switch.

- 28- One pole (S68-1) is connected to the blower (low speed tap).

- 29- The other pole (S68-2) is connected to the ACC terminal of the TB2 terminal block.

- 30- When the switch is energized S68-1,2 both close energizing the blower on low speed and the ACC terminal. This assures a blower supply when optional accessories such as an electronic air cleaner operate.

GSR21Q with GC1 Ignition Control

24V POWER TBI R

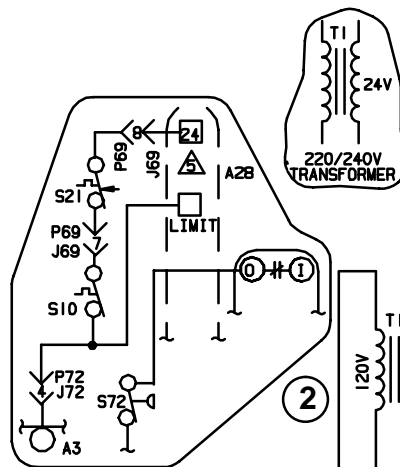

RE-WIRE S10, S21, S72 AND A3 AS SHOWN. THIS NEW WIRING SEQUENCE WILL ENABLE THE INDOOR BLOWER MOTOR (B3), TO ENERGIZE IF THE PRIMARY (S10) LIMIT SWITCH OR SECONDARY (S21) LIMIT SWITCH SHOULD OPEN.

NOTE- REMOVE JUMPER WIRE BETWEEN TERMINALS 24 & LIMIT ON A28 CONTROL.

SET THERMOSTAT HEAT ANTICIPATION ACCORDING TO AMPERAGE LISTING ON UNIT NAME PLATE OR USE THE FOLLOWING FOR A GUIDE. UNITS WITH: WHITE-RODGERS VALVE---.6 ROBERTSHAW---.8

▲ S21 IS AUTO RESET ON -6 UNITS ONLY

NOTE-IF ANY WIRE IN THIS APPLIANCE IS REPLACED, IT MUST BE REPLACED WITH WIRE OF LIKE SIZE, RATING AND INSULATION THICKNESS. IF RATING AND INSULATION ARE UNKNOWN, USE SAME SIZE THERMOPLASTIC 105°C WIRE WITH 5/64" INSULATION THICKNESS

--- LOW VOLTAGE FIELD WIRING
 ——— LINE VOLTAGE FIELD INSTALLED

KEY	DESCRIPTION
A3	CONTROL-BURNER
A18	WATCHGUARD-CIRCUIT W61
A28	CONTROL-FAN TIMER(FTC)
B3	MOTOR-BLOWER
B6	MOTOR-COMB. AIR BLOWER
C4	CAPACITOR-BLOWER MOTOR
F1	FUSE-TRANSFORMER, T1
GVI	VALVE-GAS
J43	JACK-BLOWER MOTOR
J69	JACK-BLOWER DECK
J72	JACK-PRIMARY CONTROL
K3-1,2	CONTACTOR-BLOWER RELAY
K36-1	RELAY-HEAT BLOWER
K43-1	RELAY, ECONOMIZER
P43	PLUG-BLOWER MOTOR
P69	PLUG-BLOWER DECK
P72	PLUG-PRIMARY CONTROL
S10	SWITCH-LIMIT, PRIMARY GAS
S21	SWITCH-LIMIT, SEC. GAS
S51	SWITCH-DOOR INTERLOCK
S68-1,2	SWITCH-3RD SPEED ON-OFF
S71	SWITCH-AUXILIARY FAN
S72	SWITCH-DIFF. PRESSURE
T1	TRANSFORMER-CONTROL
TBI	TERMINAL STRIP-LOW VOLT
TB2	TERMINAL STRIP- UNIT

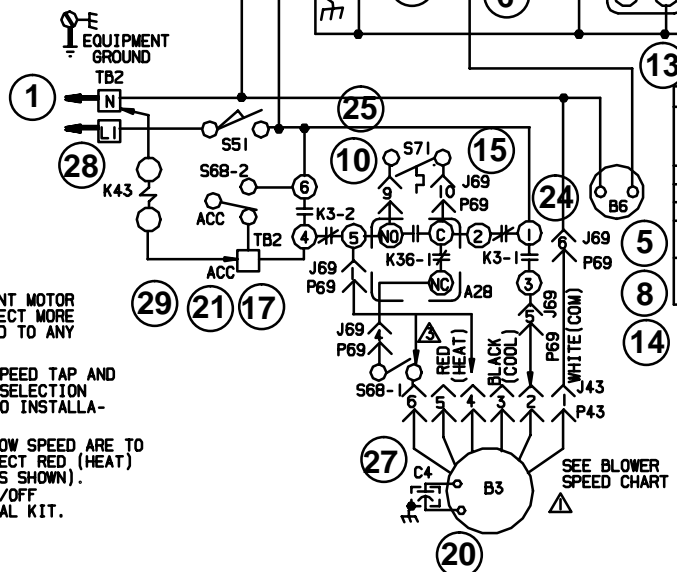

▲ TERMINAL ⓐ MAY NOT BE PROVIDED ON ALL THERMOSTATS

24V COMMON C

UNIT	FACTORY CONNECTED SPEED TAPS		MOTOR SPEEDS AVAILABLE
	COOL	HEAT	
03-50, 04	2	5	4
03-80		4	
04/5		6	5

SPEED TAPS	HI ← → LO				
	2	3	4	5	6
	2	3	4	5	4
	2	3	4	5	6

IMPORTANT-TO PREVENT MOTOR BURNOUT, NEVER CONNECT MORE THAN ONE MOTOR LEAD TO ANY ONE CONNECTION

▲ TO CHANGE MOTOR SPEED TAP AND FOR BLOWER SPEED SELECTION PROCEDURE, REFER TO INSTALLATION INSTRUCTION.

▲ IF HEATING AND LOW SPEED ARE TO BE THE SAME, CONNECT RED (HEAT) WIRE TO S68-1 (AS SHOWN). S68, 3RD SPEED ON/OFF SWITCH IS OPTIONAL KIT.

LENNOX Industries Inc. WIRING DIAGRAM 10/91 6/98

HEATING UNITS-GAS

GSR2103-50, 80, -4, 5, 6
 GSR2104-50-4, 5, 6
 GSR2104/5-80, 100-4, 5, 6

120/60/1

Supersedes Form No. _____ New Form No. 529, 417W

© 1998 Lennox Industries Inc. Litho U.S.A.

Sequence of Operation GSR21Q with GC1 Ignition Control

J-APPLICATION OF GSR21Q WITH GC1 IGNITION CONTROL

This flowchart is used to show the step by step sequence that takes place when thermostat demand is sent to the GSR21Q. The sequence describes the actions of devices in the unit which control blowers, fans, gas valve and other components in the system. The sequence is outlined by numbered steps which correspond to circled numbers on the adjacent diagram.

NOTE- This is basic operation sequence for the GSR21Q. The thermostat shown is a basic electromechanical thermostat.

Operation Sequence:

- 1- Line voltage feeds through door interlock switch S51. The blower access panel must be in place to energize the unit.
- 2- Line voltage energizes transformer T1. Transformer T1 provides 24VAC power to all unit controls, terminal strip and thermostat.

Heating:

- 3- Heating demand initiates at W1 in the thermostat. Heating demand passes through normally closed contacts of external Watchguard. This starts the Watchguard timer. Watchguard will break and remake thermostat demand in 60 ± 5 minutes.
- 4- Heating demand continues through secondary gas limit S21 to primary gas limit S10 through the differential pressure switch S72 enabling ignition control A3.
- 5- Combustion air blower B6 is energized for 30 ± 2 seconds by ignition control A3.
- 6- Gas valve opens and attempts for ignition occur.
- 7- Fan timing control A28 is energized by gas valve GV1.
- 8- After ignition is sensed, GC1 continues sparking and the combustion air blower is energized for the remaining time of the ignition attempt.
- 9- After 45 seconds of successful ignition A28 energizes K36.
- 10- K36-1 N.O. closes energizing the blower B3 on heating speed and ACC terminal of TB2 is energized.

End of Heating Demand:

- 11- Heating demand is satisfied.

- 12- Ignition control A3 is de-energized.

- 13- Gas valve GV1 closes. Pulse cycle stops.

- 14- Combustion air blower B6 is energized for 30 ± 2 seconds post purge by ignition control A3.

- 15- A28 continues to power blower motor B3 for the adjustable time. 120-240 seconds.

- 16- After the adjustable delay, K36 is de-energized.

- 17- K36-1 closes de-energizing blower motor B3.

Blower Only:

- 18- Blower demand originates in the thermostat terminal G.

- 19- Blower contactor K3 is energized.

- 20- K3-1 N.O. closes energizing blower (black tap).

- 21- K3-2 N.O. closes energizing ACC terminal on TB2 terminal strip.

Cooling Demand:

NOTE: Y TERMINAL ON LOW VOLTAGE TERMINAL STRIP IS USED FOR CONNECTING THERMOSTAT TO OUTDOOR UNIT (JUNCTION BLOCK). THE Y TERMINAL HAS NO INTERNAL CONNECTIONS TO THE UNIT.

- 22- Blower demand originates in the thermostat terminal G.

- 23- Blower contactor K3 is energized.

- 24- K3-1 N.O. closes energizing blower on cooling speed (black tap).

- 25- K3-2 N.O. closes energizing accessories terminal on TB2 terminal strip.

Single-Stage or Two-Stage Cooling With CCB1 (EBR1 Required)

See Table 20 for operating characteristics.

Continuous Low Blower Kit-Optional

- 26- S68 is a DPST switch.

- 27- One pole (S68-1) is connected to the blower (low speed tap).

- 28- The other pole (S68-2) is connected to the ACC terminal of the TB2 terminal block.

- 29- When the switch is energized S68-1,2 both close energizing the blower on low speed and the ACC terminal. This assures a blower supply when optional accessories such as an electronic air cleaner operate.

G21V with GC1 Ignition Control

⚠ USE COPPER CONDUCTORS ONLY. REFER TO UNIT RATING PLATE FOR MINIMUM CIRCUIT AMPACITY AND MAXIMUM FUSE SIZE
NEC/CEC CLASS 2

REFER TO FACTORY BLOWER SPEED TAP SELECTION CHART ON UNIT FOR BLOWER SPEED INFORMATION

⚠ SET FAN SWITCH AT "ON" POSITION FOR LOW SPEED CONTINUOUS FAN OPERATION

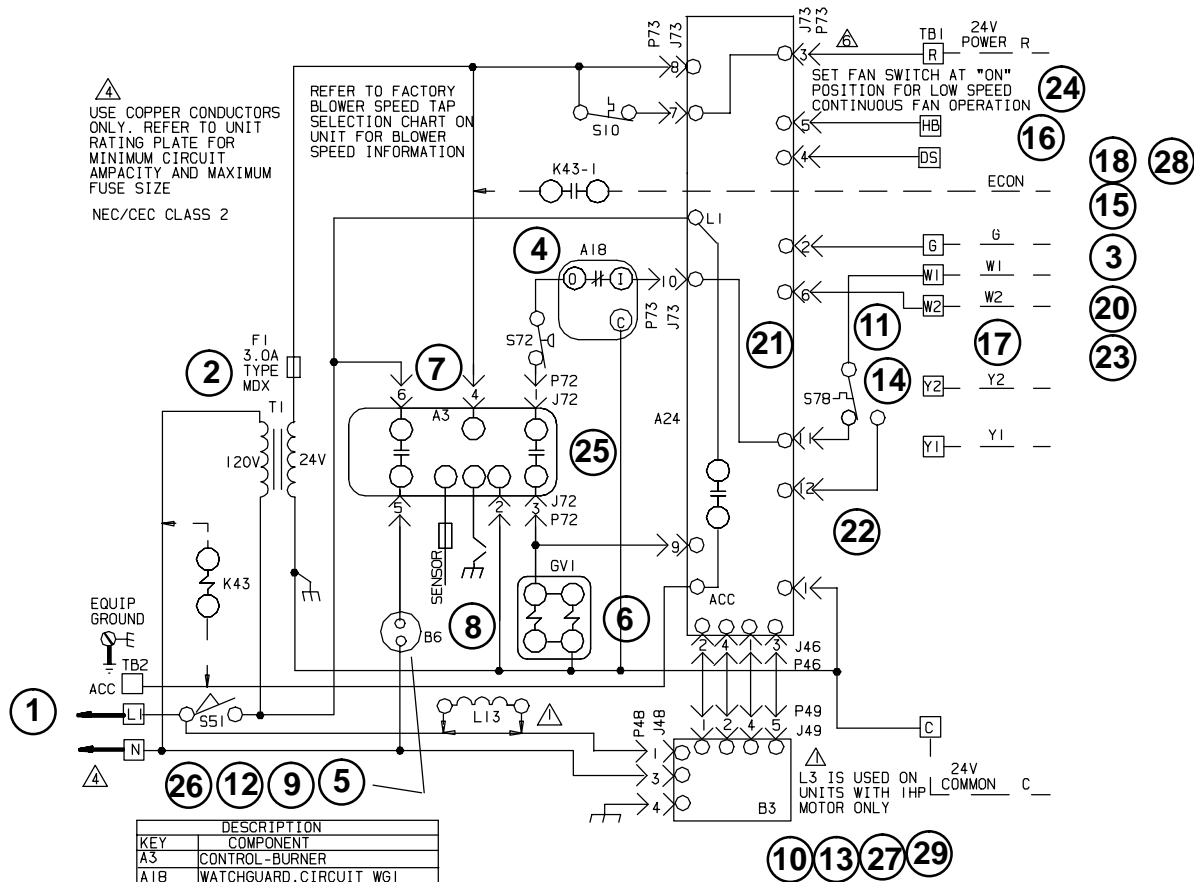

KEY	DESCRIPTION
A3	CONTROL - BURNER
A18	WATCHGUARD CIRCUIT WG1
A24	CONTROL - VSP
B3	MOTOR - BLOWER
B6	MOTOR - COMB. AIR BLOWER
F1	FUSE - TRANSFORMER, T1
GV1	VALVE - GAS
J46	JACK - OUTPUT
J48	JACK - MOTOR, VAR. SPD.
J49	JACK - MOTOR, VAR. SPD.
J72	JACK - PRIMARY CONTROL
J73	JACK - VSP CONTROL
K43, -1	RELAY - ECONOMIZER
L13	COIL - CHOKE
P46	PLUG - OUTPUT
P48	PLUG - MOTOR, VAR. SPD.
P49	PLUG - MOTOR, VAR. SPD.
P72	PLUG - PRIMARY CONTROL
P73	PLUG - VSP CONTROL
S10	SWITCH - LIMIT, PRI. GAS
S51	SWITCH - DOOR INTERLOCK
S72	SWITCH - DIFF. PRESSURE
S78	SWITCH - MODULATION CONTROL
T1	TRANSFORMER - CONTROL
TB1	TERMINAL STRIP - LOW VOLTAGE
TB2	TERMINAL STRIP - UNIT

— LINE VOLTAGE FIELD WIRING
- - CLASS II VOLTAGE FIELD WIRING

LENNOX Industries Inc. WIRING DIAGRAM 10/91

HEATING UNITS-GAS

G21V3-60, 80-2
G21V5-80, 100-2
120/60/1

Supersedes Form No. _____ New Form No. 529, 414W

Sequence of Operation G21V With GC1 Ignition Control

K-OPERATION SEQUENCE G21V WITH GC1 IGNITION CONTROL

This flowchart is used to show the step by step sequence that takes place when thermostat demand is sent to the G21V. The sequence describes the actions of devices in the unit which control blowers, fans, gas valve and other components in the system. The sequence is outlined by numbered steps which correspond to circled numbers on the adjacent diagram.

NOTE: If a single stage thermostat is to be used, "HB" and "W2" terminals should be jumpered together. This forces the blower to run on the high speed heat tap and stops frequent cycling which would occur. When the blower operates on the low speed heat/cool tap, reduced air flow causes heat exchanger temperatures to rise above the modulation control (S78) set point. The upper modulation limit will trip interrupting the W1 signal and energizing the blower. As the blower continues to run and the temperatures decrease, the lower modulation limit will trip resetting the W1 signal if there is still a call for heat.

NOTE: This is a basic operation sequence for the G21V. The thermostat shown is a basic electromechanical thermostat.

Operation Sequence

- 1- Line voltage feeds through door interlock switch S51. The blower access panel must be in place to energize the unit. (NOTE- Blower motor is always energized, S51 does not interrupt power to blower motor.)
- 2- Line voltage energizes transformer T1. Transformer T1 provides 24VAC power to all unit controls, terminal strip. Thermostat is energized after 24 VAC passes through normally closed primary limit S10.

Heating-Single Stage-NO JUMPERS

(APPLICATIONS WITH A SINGLE-STAGE THERMOSTAT)

- 3- Heating demand initiates at W1 in the thermostat. Heating demand passes through modulation control switch S78 to terminal 11 of VSP1.
- 4- Terminal 10 of VSP1 energizes ignition control A3 passing through N.C. differential pressure switch S72. External Watchguard is enabled. Watchguard will break and remake signal to VSP1 every 60 ± 5 minutes of heating call.
- 5- Combustion air blower B6 is energized for 30 ± 2 seconds by ignition control A3.
- 6- Gas valve GV1 is energized by terminal 3 of ignition control A3.
- 7- Attempts for ignition occur.
- 8- After ignition is sensed, GC1 continues sparking and the combustion air blower is energized for the remaining time of the ignition attempt.
- 9- Combustion air blower B6 is de-energized.
- 10- VSP1 internal circuitry starts blower on low speed heat/cool tap after a 45 second delay. After approximately 3-10 minutes heat exchanger temperatures will have risen to the set point of modulation control S78.
- 11- S78 will open, interrupting signal to VSP1 and in turn ignition control A3 is de-energized closing gas valve.
- 12- Combustion air blower B6 is energized for 30 ± 2 seconds by ignition control A3.
- 13- VSP1 internal circuitry forces blower to operate on low speed heat/cool tap, reducing heat exchanger temperature.
- 14- When heat exchanger temperature falls below the modulation control set point, modulation limit S78 closes and signal to VSP1 is remade. If there is still a call for heat, unit will attempt ignition and operate until S78 cycles again.

Heating-Single Stage HB Jumpered to W2

(APPLICATIONS WITH A SINGLE-STAGE THERMOSTAT)

- 15- The thermostat calls for heat (W1). Ignition is established. See steps 3-8.

- 16- Internal circuitry of the VSP1 forces the blower to run on high speed heat tap when HB and W2 are jumpered together via the field installed jumper. Blower operates on high speed heat tap.

- 17- Heat exchanger temperatures are kept below modulation control S78 opening set point. Modulation control S78 is now acting as a safety limit.

Heating-Two Stage

(APPLICATIONS WITH A TWO-STAGE THERMOSTAT)

Stage One:

- 18- The thermostat calls for heat (W1). Ignition is established. See steps 3-8.
- 19- The unit operates in the first stage of heating. See steps 9-13.

Stage Two:

- 20- The thermostat calls for heat (W2). Ignition is established. See steps 3-8.
- 21- Pin 6 of VSP1 is energized. Internal circuitry of the VSP1 forces the blower to run on high speed heat tap.
- 22- Heat exchanger temperatures are kept below modulation control S78 opening set point.

Heating-Zone Control System Used-No Jumpers

Stage One:

- 23- The thermostat calls for heat (W1). Ignition is established. See steps 3-8.
- 24- When the Harmony Zone Control System is used, the motor does not run at the low speed heat/cool or the high speed heating tap. Zone controller internal circuitry provides the DS terminal (Pin 4) to control blower speed based upon zone demands. Speed is determined by a PWM signal. Blower speed is based on the PWM signal determined by the number of zones calling.

End of Heating Demand:

- 25- Heating demand is satisfied. Ignition control A3 is de-energized. Gas valve GV1 closes. Pulse cycle stops.
- 26- Combustion air blower B6 is energized for 30 ± 2 seconds by ignition control A3.
- 27- VSP1 internal circuitry continues to power blower motor B3 on low speed heat/cool tap for the adjustable time 90-330 seconds. After the adjustable delay, B3 is de energized.

Blower Only:

- 28- Blower demand G originates in the thermostat. Terminal 2 of VSP1 is energized.
- 29- VSP1 internal circuitry forces blower to operate on low speed heat/cool tap. Blower operates on low speed heat/cool tap.

Cooling-Single Stage-No CCB1, No Harmony, DS Jumpered to G

(APPLICATIONS WITH A SINGLE-STAGE THERMOSTAT)

- 30- Refer to table 22 for operation characteristics.

Cooling-Two Stage-No CCB1, No Harmony, DS Jumpered to Y2

(APPLICATIONS WITH A TWO-STAGE THERMOSTAT)

Stage One:

- 31- Refer to table 22 for operation characteristics.

Stage Two:

- 32- Refer to table 22 for operation characteristics.

Cooling-CCB1 Used with Single-Speed or Two-Speed Compressor, No Harmony, No Jumpers

- 33- Refer to table 22 for operation characteristics.

Cooling-Harmony Zone Control Used With Single-Speed or Two-Speed Compressor, No CCB1, No Jumpers

- 34- Refer to table 22 for operation characteristics.

G21V with GC3 Ignition Control

USE COPPER CONDUCTORS ONLY. REFER TO UNIT RATING PLATE FOR MINIMUM CIRCUIT AMPACITY AND MAXIMUM FUSE SIZE
NEC/CEC CLASS 2

REFER TO FACTORY BLOWER SPEED TAP SELECTION CHART ON UNIT FOR BLOWER SPEED INFORMATION

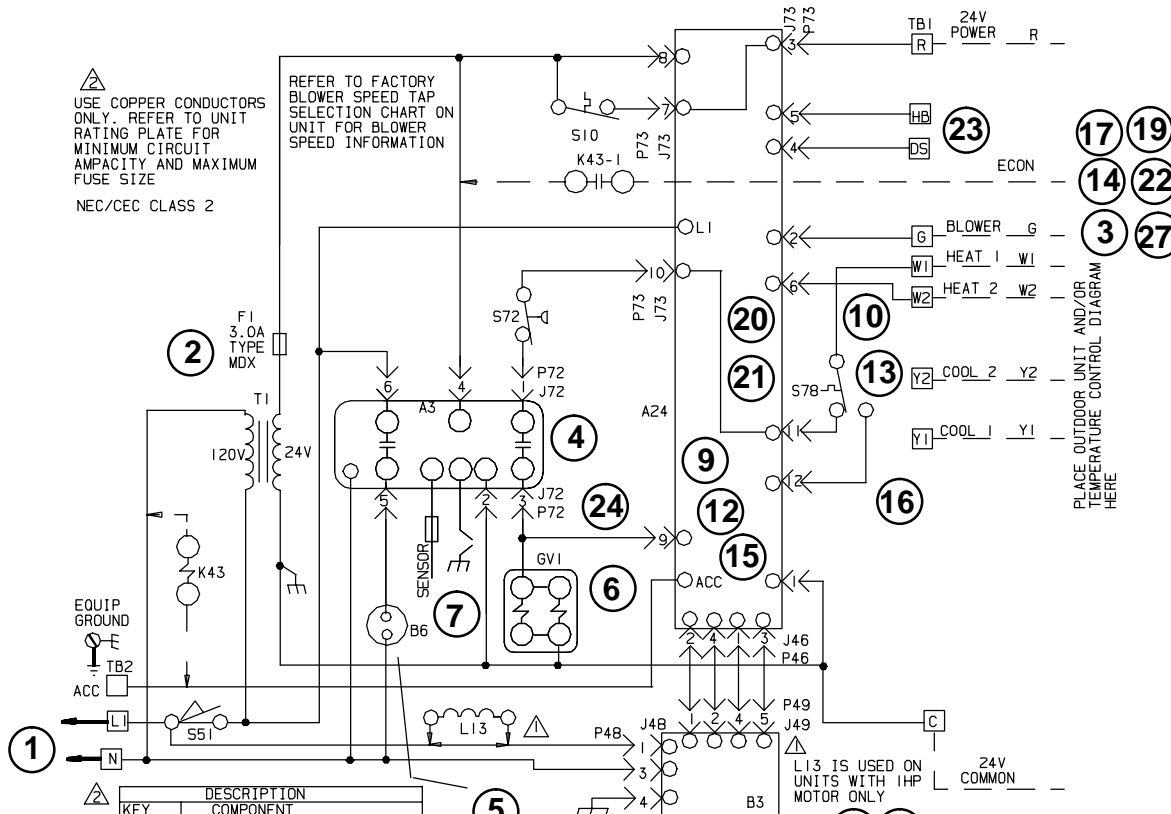

PLACE OUTDOOR UNIT AND/OR TEMPERATURE CONTROL DIAGRAM HERE

KEY	DESCRIPTION COMPONENT
A3	CONTROL-BURNER
A24	CONTROL-VSP
B3	MOTOR-BLOWER
B6	MOTOR-COMB. AIR BLOWER
F1	FUSE-TRANSFORMER, T1
GV1	VALVE-GAS
J46	JACK-OUTPUT
J48	JACK-MOTOR, VAR. SPD.
J49	JACK-MOTOR, VAR. SPD.
J72	JACK-PRIMARY CONTROL
J73	JACK-VSP CONTROL
K43-1	RELAY-ECONOMIZER
L13	COIL-CHOKE
P46	PLUG-OUTPUT
P48	PLUG-MOTOR, VAR. SPD.
P49	PLUG-MOTOR, VAR. SPD.
P72	PLUG-PRIMARY CONTROL
P73	PLUG-VSP CONTROL
S1	THERMOSTAT-ROOM
S10	SWITCH-LIMIT, PRI. GAS
S51	SWITCH-DOOR INTERLOCK
S72	SWITCH-DIFF. PRESSURE
S78	SWITCH-MODULATION CONTROL
T1	TRANSFORMER-CONTROL
TB1	TERMINAL STRIP-LOW VOLTAGE
TB2	TERMINAL STRIP-UNIT

- 5
 - 8
 - 11
 - 25
- LINE VOLTAGE FIELD WIRING
 - - CLASS II VOLTAGE FIELD INSTALLED
- ← DENOTES OPTIONAL COMPONENTS

LENNOX Industries Inc. WIRING DIAGRAM 2/91	
HEATING UNITS-GAS	
G21V3-60, 80-1	
G21V5-80, 100-1	
120/60/1	
Supersedes Form No. 529, 357W	New Form No. 529, 505W
© 1991 Lennox Industries Inc. Litho U.S.A.	

Sequence of Operation G21V With GC3 Ignition Control

L-OPERATION SEQUENCE G21V WITH GC3 IGNITION CONTROL

This flowchart is used to show the step by step sequence that takes place when thermostat demand is sent to the G21V. The sequence describes the actions of devices in the unit which control blowers, fans, gas valve and other components in the system. The sequence is outlined by numbered steps which correspond to circled numbers on the adjacent diagram.

NOTE: If a single stage thermostat is to be used, "HB" and "W2" terminals should be jumpered together. This forces the blower to run on the high speed heat tap and stops frequent cycling which would occur. When the blower operates on the low speed heat/cool tap, reduced air flow causes heat exchanger temperatures to rise above the modulation control (S78) set point. The upper modulation limit will trip interrupting the W1 signal and energizing the blower. As the blower continues to run and the temperatures decrease, the lower modulation limit will trip resetting the W1 signal if there is still a call for heat.

NOTE: This is a basic operation sequence for the G21V. The thermostat shown is a basic electromechanical thermostat.

Operation Sequence

- 1- Line voltage feeds through door interlock switch S51. The blower access panel must be in place to energize the unit. (NOTE- Blower motor is always energized, S51 does not interrupt power to blower motor.)
- 2- Line voltage energizes transformer T1. Transformer T1 provides 24VAC power to all unit controls, terminal strip. Thermostat is energized after 24 VAC passes through normally closed primary limit S10.

Heating-Single Stage-NO JUMPERS

(APPLICATIONS WITH A SINGLE-STAGE THERMOSTAT)

- 3- Heating demand initiates at W1 in the thermostat. Heating demand passes through modulation control switch S78 to terminal 11 of VSP1.
- 4- Terminal 10 of VSP1 energizes ignition control A3 passing through N.C. differential pressure switch S72.
- 5- Combustion air blower B6 is energized for 30 ± 5 seconds by ignition control A3.
- 6- Gas valve GV1 is energized by terminal 3 of ignition control A3.
- 7- Attempts for ignition occur. Internal Watchguard is enabled only if ignition fails to light unit (5 tries). Watchguard will break and remake thermostat demand in 60 ± 5 minutes.
- 8- Combustion air blower B6 and ignition control A3 are de-energized .5 seconds after ignition is sensed or after 8.0 seconds if ignition is not sensed.
- 9- VSP1 internal circuitry starts blower on low speed heat/cool tap after a 45 second delay. After approximately 3-10 minutes heat exchanger temperatures will have risen to the set point of modulation control S78.
- 10- S78 will open, interrupting signal to VSP1 and in turn ignition control A3 is de-energized closing gas valve.
- 11- Combustion air blower B6 is energized for 30 ± 5 seconds by ignition control A3.
- 12- VSP1 internal circuitry forces blower to operate on low speed heat/cool tap, reducing heat exchanger temperature.
- 13- When heat exchanger temperature falls below the modulation control set point, modulation limit S78 closes and signal to VSP1 is remade. If there is still a call for heat, unit will attempt ignition and operate until S78 cycles again.

Heating-Single Stage HB Jumpered to W2

(APPLICATIONS WITH A SINGLE-STAGE THERMOSTAT)

- 14- The thermostat calls for heat (W1). Ignition is established. See steps 3-9.

- 15- Internal circuitry of the VSP1 forces the blower to run on high speed heat tap when HB and W2 are jumpered together via the field installed jumper. Blower operates on high speed heat tap.

- 16- Heat exchanger temperatures are kept below modulation control S78 opening set point. Modulation control S78 is now acting as a safety limit.

Heating-Two Stage (APPLICATIONS WITH A TWO-STAGE THERMOSTAT)

Stage One:

- 17- The thermostat calls for heat (W1). Ignition is established. See steps 3-9.
- 18- The unit operates in the first stage of heating. See steps 10-13.

Stage Two:

- 19- The thermostat calls for heat (W2). Ignition is established. See steps 3-9.
- 20- Pin 6 of VSP1 is energized. Internal circuitry of the VSP1 forces the blower to run on high speed heat tap.
- 21- Heat exchanger temperatures are kept below modulation control S78 opening set point.

Heating-Zone Control System Used-HB NOT Jumpered to W2

Stage One:

- 22- The thermostat calls for heat (W1). Ignition is established. See steps 3-9.
- 23- When the Harmony Zone Control System is used, the motor does not run at the low speed heat/cool or the high speed heating tap. Zone controller internal circuitry provides the DS terminal (Pin 4) to control blower speed based upon zone demands. Speed is determined by a PWM signal. Blower speed is based on the PWM signal determined by the number of zones calling.

End of Heating Demand:

- 24- Heating demand is satisfied. Ignition control A3 is de-energized. Gas valve GV1 closes. Pulse cycle stops.
- 25- Combustion air blower B6 is energized for 30 ± 5 seconds by ignition control A3.
- 26- VSP1 internal circuitry continues to power blower motor B3 on low speed heat/cool tap for the adjustable time 90-330 seconds. After the adjustable delay, B3 is de energized.

Blower Only:

- 27- Blower demand G originates in the thermostat. Terminal 2 of VSP1 is energized.
- 28- VSP1 internal circuitry forces blower to operate on low speed heat/cool tap. Blower operates on low speed heat/cool tap.

Cooling-Single Stage-No CCB1, No Harmony, DS Jumpered to G (APPLICATIONS WITH A SINGLE-STAGE THERMOSTAT)

- 29- Refer to table 22 for operation characteristics.

Cooling-Two Stage-No CCB1, No Harmony, DS Jumpered to Y2 (APPLICATIONS WITH A TWO-STAGE THERMOSTAT)

Stage One:

- 30- Refer to table 22 for operation characteristics.

Stage Two:

- 31- Refer to table 22 for operation characteristics.

Cooling-CCB1 Used with Single-Speed or Two-Speed Compressor, No Harmony, No Jumpers

- 32- Refer to table 22 for operation characteristics.

Cooling-Harmony Zone Control Used With Single-Speed or Two-Speed Compressor, No CCB1, No Jumpers

- 33- Refer to table 22 for operation characteristics.

GSR21V with GC1 Ignition Control

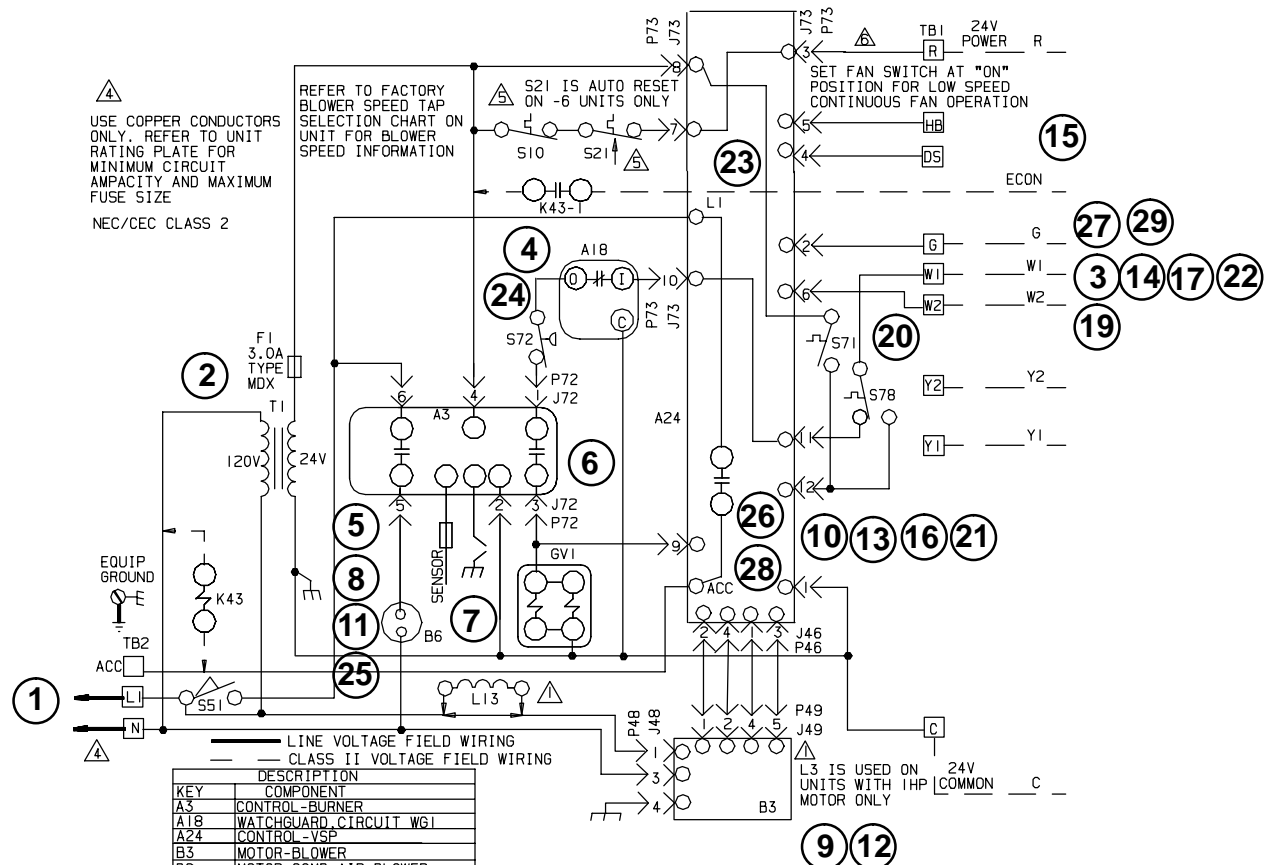

USE COPPER CONDUCTORS ONLY. REFER TO UNIT RATING PLATE FOR MINIMUM CIRCUIT AMPACITY AND MAXIMUM FUSE SIZE. NEC/CEC CLASS 2

— LINE VOLTAGE FIELD WIRING
 - - - CLASS II VOLTAGE FIELD WIRING

KEY	DESCRIPTION
A3	CONTROL - BURNER
A18	WATCHGUARD CIRCUIT WG1
A24	CONTROL - VSP
B3	MOTOR - BLOWER
B6	MOTOR - COMB. AIR BLOWER
F1	FUSE - TRANSFORMER - T1
GV1	VALVE - GAS
J46	JACK - OUTPUT
J48	JACK - MOTOR, VAR. SPD.
J49	JACK - MOTOR, VAR. SPD.
J72	JACK - PRIMARY CONTROL
J73	JACK - VSP CONTROL
K43, -1	RELAY - ECONOMIZER
L13	COIL - CHOKE
P46	PLUG - OUTPUT
P48	PLUG - MOTOR, VAR. SPD.
P49	PLUG - MOTOR, VAR. SPD.
P72	PLUG - PRIMARY CONTROL
P73	PLUG - VSP CONTROL
S10	SWITCH - LIMIT, PRI. GAS
S21	SWITCH - LIMIT, SEC. GAS
S51	SWITCH - DOOR INTERLOCK
S71	SWITCH - AUXILIARY FAN
S72	SWITCH - DIFF. PRESSURE
S78	SWITCH - MODULATION CONTROL
T1	TRANSFORMER - CONTROL
TB1	TERMINAL STRIP - LOW VOLTAGE
TB2	TERMINAL STRIP - UNIT

LENNOX Industries Inc. WIRING DIAGRAM 10/91

HEATING UNITS-GAS

GSR21V3-80-4,5,6
 GSR21V5-80,100-4,5,6
 120/60/1

Supersedes Form No. _____ New Form No. 529,415W

©1991 Lennox Industries Inc. Litho U.S.A.

Sequence of Operation GSR21V With GC1 Ignition Control

M-OPERATION SEQUENCE GSR21V WITH GC1 IGNITION CONTROL

This flowchart is used to show the step by step sequence that takes place when thermostat demand is sent to the GSR21V. The sequence describes the actions of devices in the unit which control blowers, fans, gas valve and other components in the system. The sequence is outlined by numbered steps which correspond to circled numbers on the adjacent diagram.

NOTE- A single stage thermostat is to be used. "HB" and "W2" terminals should be jumpered together. This forces the blower to run on the high speed heat tap and stops frequent cycling which would occur. When the blower operates on the low speed heat/cool tap, reduced air flow causes heat exchanger temperatures to rise above the modulation control (S78) set point. The upper modulation limit will trip interrupting the W1 signal and energizing the blower. As the blower continues to run and the temperatures decrease, the lower modulation limit will trip resetting the W1 signal if there is still a call for heat.

NOTE- This is a basic operation sequence for the GSR21V. The thermostat shown is a basic electromechanical thermostat.

Operation Sequence

- 1- Line voltage feeds through door interlock switch S51. The blower access panel must be in place to energize the unit. (NOTE- Blower motor is always energized, S51 does not interrupt power to blower motor.)
- 2- Line voltage energizes transformer T1. Transformer T1 provides 24VAC power to all unit controls, terminal strip. Thermostat is energized after 24 VAC passes through normally closed primary limit S10.

Heating-Single Stage-NO JUMPERS

(APPLICATIONS WITH A SINGLE-STAGE THERMOSTAT)

- 3- Heating demand initiates at W1 in the thermostat. Heating demand passes through modulation control switch S78 to terminal 11 of VSP1.
- 4- Terminal 10 of VSP1 energizes ignition control A3 passing through N.C. differential pressure switch S72. External Watchguard is enabled. Watchguard will break and remake signal to VSP1 every 60 ± 5 minutes of heating call.
- 5- Combustion air blower B6 is energized for 30 ± 2 seconds by ignition control A3.
- 6- Gas valve GV1 is energized by terminal 3 of ignition control A3.
- 7- Attempts for ignition occur.
- 8- After ignition is sensed, GC1 continues sparking and the combustion air blower is energized for the remaining time of the ignition attempt.
- 9- Combustion air blower B6 is de-energized.
- 10- VSP1 internal circuitry starts blower on low speed heat/cool tap after a 45 second delay. After approximately 3-10 minutes heat exchanger temperatures will have risen to the set point of modulation control S78.
- 11- S78 will open, interrupting signal to VSP1 and in turn ignition control A3 is de-energized closing gas valve.
- 12- Combustion air blower B6 is energized for 30 ± 2 seconds by ignition control A3.
- 13- VSP1 internal circuitry forces blower to operate on low speed heat/cool tap, reducing heat exchanger temperature.
- 14- When heat exchanger temperature falls below the modulation control set point, modulation limit S78 closes and signal to VSP1 is remade. If there is still a call for heat, unit will attempt ignition and operate until S78 cycles again.

Heating-Single Stage HB Jumpered to W2

(APPLICATIONS WITH A SINGLE-STAGE THERMOSTAT)

- 15- The thermostat calls for heat (W1). Ignition is established. See steps 3-8.

- 16- Internal circuitry of the VSP1 forces the blower to run on high speed heat tap when HB and W2 are jumpered together via the field installed jumper. Blower operates on high speed heat tap.

- 17- Heat exchanger temperatures are kept below modulation control S78 opening set point. Modulation control S78 is now acting as a safety limit.

Heating-Two Stage

(APPLICATIONS WITH A TWO-STAGE THERMOSTAT)

Stage One:

- 18- The thermostat calls for heat (W1). Ignition is established. See steps 3-8.
- 19- The unit operates in the first stage of heating. See steps 9-13.

Stage Two:

- 20- The thermostat calls for heat (W2). Ignition is established. See steps 3-8.
- 21- Pin 6 of VSP1 is energized. Internal circuitry of the VSP1 forces the blower to run on high speed heat tap.
- 22- Heat exchanger temperatures are kept below modulation control S78 opening set point.

Heating-Zone Control System Used-HB NOT Jumpered to W2

Stage One:

- 23- The thermostat calls for heat (W1). Ignition is . See steps 3-8.
- 24- When the Harmony Zone Control System is used, the motor does not run at the low speed heat/cool or the high speed heating tap. Zone controller internal circuitry provides the DS terminal (Pin 4) to control blower speed based upon zone demands. Speed is determined by a PWM signal. Blower speed is based on the PWM signal determined by the number of zones calling.

End of Heating Demand:

- 25- Heating demand is satisfied. Ignition control A3 is de-energized. Gas valve GV1 closes. Pulse cycle stops.
- 26- Combustion air blower B6 is energized for 30 ± 2 seconds by ignition control A3.
- 27- VSP1 internal circuitry continues to power blower motor B3 on low speed heat/cool tap for the adjustable time 90-330 seconds. After the adjustable delay, B3 is de energized.

Blower Only:

- 28- Blower demand G originates in the thermostat. Terminal 2 of VSP1 is energized.
- 29- VSP1 internal circuitry forces blower to operate on low speed heat/cool tap. Blower operates on low speed heat/cool tap.

Cooling-Single Stage-No CCB1, No Harmony, DS Jumpered to G

(APPLICATIONS WITH A SINGLE-STAGE THERMOSTAT)

- 30- Refer to table 22 for operation characteristics.

Cooling-Two Stage-No CCB1, No Harmony, DS Jumpered to Y2

(APPLICATIONS WITH A TWO-STAGE THERMOSTAT)

Stage One:

- 31- Refer to table 22 for operation characteristics.

Stage Two:

- 32- Refer to table 22 for operation characteristics.

Cooling-CCB1 Used with Single-Speed or Two-Speed Compressor, No Harmony, No Jumpers

- 33- Refer to table 22 for operation characteristics.

Cooling-Harmony Zone Control Used With Single-Speed or Two-Speed Compressor, No CCB1, No Jumpers

- 34- Refer to table 22 for operation characteristics.

GSR21V with GC3 Ignition Control

USE COPPER CONDUCTORS ONLY. REFER TO UNIT RATING PLATE FOR MINIMUM CIRCUIT AMPACITY AND MAXIMUM FUSE SIZE
NEC/CEC CLASS 2

REFER TO FACTORY BLOWER SPEED TAP SELECTION CHART ON UNIT FOR BLOWER SPEED INFORMATION

S21 IS AUTO RESET ON -3 UNITS ONLY.

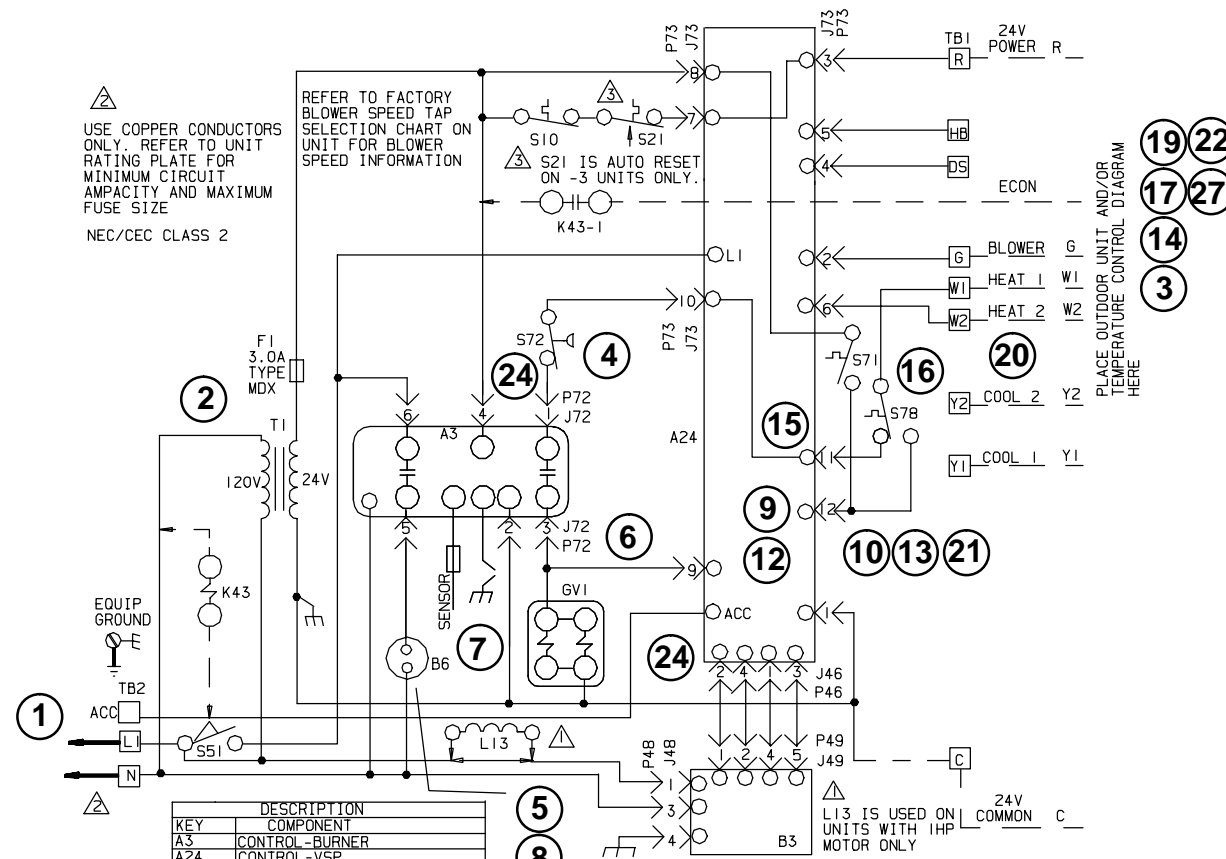

19 22
17 27
14
3
PLACE OUTDOOR UNIT AND/OR TEMPERATURE CONTROL DIAGRAM HERE

KEY	DESCRIPTION
A3	CONTROL -BURNER
A24	CONTROL -VSP
B3	MOTOR-BLOWER
B6	MOTOR-COMB. AIR BLOWER
F1	FUSE-TRANSFORMER-T1
GV1	VALVE-GAS
J46	JACK-OUTPUT
J48	JACK-MOTOR, VAR. SPD.
J49	JACK-MOTOR, VAR. SPD.
J72	JACK-PRIMARY CONTROL
J73	JACK-VSP CONTROL
K43, -1	RELAY-ECONOMIZER
L13	COIL-CHOKE
P46	PLUG-OUTPUT
P48	PLUG-MOTOR, VAR. SPD.
P49	PLUG-MOTOR, VAR. SPD.
P72	PLUG-PRIMARY CONTROL
P73	PLUG-VSP CONTROL
S1	THERMOSTAT-ROOM
S10	SWITCH-LIMIT, PRI. GAS
S21	SWITCH-LIMIT, SEC. GAS
S51	SWITCH-DOOR INTERLOCK
S71	SWITCH-AUXILIARY FAN
S72	SWITCH-DIFF. PRESSURE
S78	SWITCH-MODULATION CONTROL
T1	TRANSFORMER-CONTROL
TB1	TERMINAL STRIP-LOW VOLTAGE
TB2	TERMINAL STRIP-UNIT

— LINE VOLTAGE FIELD WIRING
- - CLASS II VOLTAGE FIELD WIRING
← DENOTES OPTIONAL COMPONENTS

LENNOX Industries Inc. WIRING DIAGRAM 11/91

HEATING UNITS-GAS

GSR21V3-80-1, 2, 3
GSR21V5-80, 100-1, 2, 3
120/60/1

Supersedes Form No. 529, 358W New Form No. 529, 506W

©1991 Lennox Industries Inc. Litho U.S.A.

Sequence of Operation GSR21V With GC3 Ignition Control

N-OPERATION SEQUENCE GSR21V WITH GC3 IGNITION CONTROL

This flowchart is used to show the step by step sequence that takes place when thermostat demand is sent to the GSR21V. The sequence describes the actions of devices in the unit which control blowers, fans, gas valve and other components in the system. The sequence is outlined by numbered steps which correspond to circled numbers on the adjacent diagram.

NOTE- If a single stage thermostat is to be used, "HB" and "W2" terminals should be jumpered together. This forces the blower to run on the high speed heat tap and stops frequent cycling which would occur. When the blower operates on the low speed heat/cool tap, reduced air flow causes heat exchanger temperatures to rise above the modulation control (S78) set point. The upper modulation limit will trip interrupting the W1 signal and energizing the blower. As the blower continues to run and the temperatures decrease, the lower modulation limit will trip resetting the W1 signal if there is still a call for heat.

NOTE- This is a basic operation sequence for the GSR21V. The thermostat shown is a basic electromechanical thermostat.

Operation Sequence

- 1- Line voltage feeds through door interlock switch S51. The blower access panel must be in place to energize the unit. (NOTE- Blower motor is always energized, S51 does not interrupt power to blower motor.)
- 2- Line voltage energizes transformer T1. Transformer T1 provides 24VAC power to all unit controls, terminal strip. Thermostat is energized after 24 VAC passes through normally closed primary limit S10.

Heating-Single Stage-NO JUMPERS

(APPLICATIONS WITH A SINGLE-STAGE THERMOSTAT)

- 3- Heating demand initiates at W1 in the thermostat. Heating demand passes through modulation control switch S78 to terminal 11 of VSP1.
- 4- Terminal 10 of VSP1 energizes ignition control A3 passing through N.C. differential pressure switch S72.
- 5- Combustion air blower B6 is energized for 30 ± 5 seconds by ignition control A3.
- 6- Gas valve GV1 is energized by terminal 3 of ignition control A3.
- 7- Attempts for ignition occur. Internal Watchguard is enabled only if ignition fails to light unit (5 tries). Watchguard will break and remake thermostat demand in 60 ± 5 minutes.
- 8- Combustion air blower B6 and ignition control A3 are de-energized .5 seconds after ignition is sensed or after 8.0 seconds if ignition is not sensed.
- 9- VSP1 internal circuitry starts blower on low speed heat/cool tap after a 45 second delay. After approximately 3-10 minutes heat exchanger temperatures will have risen to the set point of modulation control S78.
- 10- S78 will open, interrupting signal to VSP1 and in turn ignition control A3 is de-energized closing gas valve.
- 11- Combustion air blower B6 is energized for 30 ± 5 seconds by ignition control A3.
- 12- VSP1 internal circuitry forces blower to operate on low speed heat/cool tap, reducing heat exchanger temperature.
- 13- When heat exchanger temperature falls below the modulation control set point, modulation limit S78 closes and signal to VSP1 is remade. If there is still a call for heat, unit will attempt ignition and operate until S78 cycles again.

Heating-Single Stage HB Jumpered to W2

(APPLICATIONS WITH A SINGLE-STAGE THERMOSTAT)

- 14- The thermostat calls for heat (W1). Ignition is established. See steps 3-9.

- 15- Internal circuitry of the VSP1 forces the blower to run on high speed heat tap when HB and W2 are jumpered together via the field installed jumper. Blower operates on high speed heat tap.

- 16- Heat exchanger temperatures are kept below modulation control S78 opening set point. Modulation control S78 is now acting as a safety limit.

Heating-Two Stage

(APPLICATIONS WITH A TWO-STAGE THERMOSTAT)

Stage One:

- 17- The thermostat calls for heat (W1). Ignition is established. See steps 3-9.

- 18- The unit operates in the first stage of heating. See steps 10-13.

Stage Two:

- 19- The thermostat calls for heat (W2). Ignition is established. See steps 3-9.

- 20- Pin 6 of VSP1 is energized. Internal circuitry of the VSP1 forces the blower to run on high speed heat tap.

- 21- Heat exchanger temperatures are kept below modulation control S78 opening set point.

Heating-Zone Control System Used-HB NOT Jumpered to W2

Stage One:

- 22- The thermostat calls for heat (W1). Ignition is established. See steps 3-9.

- 23- When the Harmony Zone Control System is used, the motor does not run at the low speed heat/cool or the high speed heating tap. Zone controller internal circuitry provides the DS terminal (Pin 4) to control blower speed based upon zone demands. Speed is determined by a PWM signal. Blower speed is based on the PWM signal determined by the number of zones calling.

End of Heating Demand:

- 24- Heating demand is satisfied. Ignition control A3 is de-energized. Gas valve GV1 closes. Pulse cycle stops.

- 25- Combustion air blower B6 is energized for 30 ± 5 seconds by ignition control A3.

- 26- VSP1 internal circuitry continues to power blower motor B3 on low speed heat/cool tap for the adjustable time 90-330 seconds. After the adjustable delay, B3 is de energized.

Blower Only:

- 27- Blower demand G originates in the thermostat. Terminal 2 of VSP1 is energized.

- 28- VSP1 internal circuitry forces blower to operate on low speed heat/cool tap. Blower operates on low speed heat/cool tap.

Cooling-Single Stage-No CCB1, No Harmony, DS Jumpered to G

(APPLICATIONS WITH A SINGLE-STAGE THERMOSTAT)

- 29- Refer to table 22 for operation characteristics.

Cooling-Two Stage-No CCB1, No Harmony, DS Jumpered to Y2

(APPLICATIONS WITH A TWO-STAGE THERMOSTAT)

Stage One:

- 30- Refer to table 22 for operation characteristics.

Stage Two:

- 31- Refer to table 22 for operation characteristics.

Cooling-CCB1 Used with Single-Speed or Two-Speed Compressor, No Harmony, No Jumpers

- 32- Refer to table 22 for operation characteristics.

Cooling-Harmony Zone Control Used With Single-Speed or Two-Speed Compressor, No CCB1, No Jumpers

- 33- Refer to table 22 for operation characteristics.

TABLE 18

G21V/GSR21V OPERATION SEQUENCE AND JUMPERS SUMMARY WITH VSP2-1 (HEATING)

MATCH UP	JUMPER	COMMENTS OR SEQUENCE	WIRING CONNECTIONS
<p>FOR COOLING JUMPERS SEE TABLE 19</p> <p>Single-Stage Heating</p>	<p>Heating Blower Jumper in position # 1</p> <hr/> <p>Heating Blower Jumper in position # 2</p>	<p>Blower operates on heating speed. Modulation control S78 may not cycle the unit. If NM is used instead of W1, blower operates on heating speed and no modulation occurs.</p> <hr/> <p>Blower operates on low speed. Modulation control S78 will cycle the unit. If NM is used instead of W1, blower operates on low speed and no modulation occurs.</p>	<p>* If no modulation is desired, wire heat demand (W1) from thermostat to NM on terminal strip.</p> <p>--- CLASS II VOLTAGE FIELD WIRING</p>
<p>Two-Stage Heating</p>	<p>Heating Blower Jumper in position # 2</p>	<p>Blower operates on the low speed heat/cool tap during the first stage of heating. Modulation control S78 will cycle the unit. Blower operates on the high speed heat tap during second stage heating. Modulation control S78 may not cycle the unit.</p> <p><i>NOTE: Two-Stage heating is not available when using the non-modulation NM terminal</i></p>	<p>--- CLASS II VOLTAGE FIELD WIRING</p>
<p>Harmony Heating</p>	<p>Heating Blower Jumper MUST BE in position # 2</p>	<p>Blower operates on PWM signal generated by Harmony. Harmony overrides blower speed taps. Blower speed varies according to zone demand.</p>	<p>--- CLASS II VOLTAGE FIELD WIRING</p>

TABLE 19

G21V/GSR21V OPERATION SEQUENCE AND JUMPERS SUMMARY WITH VSP2-1 (COOLING)

MATCH UP	JUMPER	COMMENTS OR SEQUENCE	WIRING CONNECTIONS
<p>FOR HEATING JUMPERS SEE TABLE 18</p> <p>Single-Speed Compressor, no CCB1, no Harmony</p>	<p>“DS” to “G”</p>	<p>Blower operates on high speed cool tap during cooling.</p>	
<p>Two-Speed Compressor, no CCB1, no Harmony</p>	<p>“DS” to “Y2”</p>	<p>Blower operates on low speed heat/cool tap when compressor is in first stage cooling. Blower operates on high speed cool tap when compressor is in second stage cooling.</p>	
<p>CCB1 with Single-Speed Compressor, no Harmony</p>	<p>No Jumpers</p>	<p>Blower speed is controlled by the DC signal from CCB1. Blower operates on low speed heat/cool tap during dehumidification. Otherwise, blower operates on high speed cool tap during cooling cycle.</p>	

Page 94

(continued on following page)

(continued from previous page)

TABLE 19 (contd.)

G21V/GSR21V OPERATION SEQUENCE AND JUMPERS SUMMARY WITH VSP2-1 (COOLING)

MATCH UP	JUMPER	COMMENTS OR SEQUENCE	WIRING CONNECTIONS
<p>FOR HEATING JUMPERS SEE TABLE 18</p> <p>CCB1 with Two-Speed Compressor, no Harmony</p>	<p>No Jumpers</p>	<p>Blower speed is controlled by the DC signal from CCB1. Blower operates on low speed heat/cool tap during dehumidification. Otherwise, blower operates on high speed cool tap during high speed compressor operation and low speed heat/cool tap during low speed compressor operation</p>	
<p>Harmony and Single-Speed Compressor</p>	<p>No Jumpers</p>	<p>Blower operates on PWM signal generated by Harmony. Harmony overrides blower speed taps. Blower speed varies according to zone demand.</p>	
<p>Harmony and Two-Speed Compressor</p>	<p>No Jumpers</p>	<p>Blower operates on PWM signal generated by Harmony. Harmony overrides blower speed taps. Blower speed varies according to zone demand.</p>	

TABLE 20

G21Q/GSR21Q OPERATION SEQUENCE AND JUMPERS SUMMARY WITH VSP1 OR VSP2-1 (OPTIONAL COOLING ACCESSORIES)

MATCH UP	JUMPER	COMMENTS OR SEQUENCE	WIRING CONNECTIONS
<p>EBR1 With CCB1 And Single-Speed Compressor</p>	<p>No Jumpers Additional Wiring Required inside Unit. Refer to EBR1 Blower Relay Kit Installation Instructions</p>	<p>Blower operates on a lower speed tap during dehumidification. Otherwise, blower operates on cooling tap during cooling cycle.</p>	
<p>EBR1 With CCB1 And Two-Speed Compressor</p>	<p>No Jumpers Additional Wiring Required inside Unit. Refer to EBR1 Blower Relay Kit Installation Instructions</p>	<p>Blower operates on a lower speed tap during dehumidification. Otherwise, blower operates on cooling tap during cooling cycle.</p>	

TABLE 21

G21V/GSR21V OPERATION SEQUENCE AND JUMPERS SUMMARY WITH VSP1 (HEATING)

MATCH UP	JUMPER	COMMENTS OR SEQUENCE	WIRING CONNECTIONS
<p>FOR COOLING JUMPERS SEE TABLE 22</p> <p>Single-Stage Heating</p>	<p>"HB" to "W2"</p>	<p>Blower operates on the high speed heat tap during the heating mode.</p>	
<p>Two-Stage Heating</p>	<p>No Jumpers</p>	<p>Blower operates on the low speed heat/cool tap during the first stage of heating. Modulation control S78 will cycle the unit. Blower operates on the high speed heat tap during second stage heating. Modulation control S78 may not cycle the unit.</p>	
<p>Harmony Heating</p>	<p>No Jumpers</p>	<p>Blower operates on PWM signal generated by Harmony. Harmony overrides blower speed taps. Blower speed varies according to zone demand.</p>	

TABLE 22

G21V/GSR21V OPERATION SEQUENCE AND JUMPERS SUMMARY WITH VSP1 (COOLING)

MATCH UP	JUMPER	COMMENTS OR SEQUENCE	WIRING CONNECTIONS
<p>FOR HEATING JUMPERS SEE TABLE 21</p> <p>Single-Speed Compressor, no CCB1, no Harmony</p>	<p>"DS" to "G"</p>	<p>Blower operates on high speed cool tap during cooling.</p>	<p>TO OUTDOOR UNIT</p> <p>24V POWER</p> <p>S1 THERMOSTAT</p> <p>TO OUTDOOR UNIT</p> <p>G W1 W2 R Y1 Y2 DS C HB</p> <p>TB1 TERMINAL STRIP</p> <p>BLOWER DS</p> <p>COOL</p> <p>24V COMMON</p> <p>CLASS II VOLTAGE FIELD WIRING</p>
<p>Two-Speed Compressor, no CCB1, no Harmony</p>	<p>"DS" to "Y2"</p>	<p>Blower operates on low speed heat/cool tap when compressor is in first stage cooling. Blower operates on high speed cool tap when compressor is in second stage cooling.</p>	<p>TO OUTDOOR UNIT</p> <p>24V POWER</p> <p>S1 THERMOSTAT</p> <p>TO OUTDOOR UNIT</p> <p>G W1 W2 R Y1 Y2 DS C HB</p> <p>TB1 TERMINAL STRIP</p> <p>BLOWER DS</p> <p>COOL_2</p> <p>COOL_1</p> <p>24V COMMON</p> <p>CLASS II VOLTAGE FIELD WIRING</p>
<p>CCB1 with Single-Speed Compressor, no Harmony</p>	<p>No Jumpers</p>	<p>Blower speed is controlled by the DC signal from CCB1. Blower operates on low speed heat/cool tap during dehumidification. Otherwise, blower operates on high speed cool tap during cooling cycle.</p>	<p>TO OUTDOOR UNIT</p> <p>24V POWER</p> <p>S1 THERMOSTAT</p> <p>TO OUTDOOR UNIT</p> <p>G W1 W2 R Y1 Y2 DS C HB</p> <p>TB1 TERMINAL STRIP</p> <p>BLOWER DS</p> <p>COOL_1</p> <p>24V COMMON</p> <p>A20 HUMIDITY CONTROL</p> <p>CLASS II VOLTAGE FIELD WIRING</p>

(continued on following page)

(continued from previous page)

TABLE 22 (contd.)

G21V/GSR21V OPERATION SEQUENCE AND JUMPERS SUMMARY WITH VSP1 (COOLING)

MATCH UP	JUMPER	COMMENTS OR SEQUENCE	WIRING CONNECTIONS
<p>FOR HEATING JUMPERS SEE TABLE 21</p> <p>CCB1 with Two-Speed Compressor, no Harmony</p>	<p>No Jumpers</p>	<p>Blower speed is controlled by the DC signal from CCB1. Blower operates on low speed heat/cool tap during dehumidification. Otherwise, blower operates on high speed cool tap during high speed compressor operation and low speed heat/cool tap during low speed compressor operation</p>	
<p>Harmony and Single-Speed Compressor</p>	<p>No Jumpers</p>	<p>Blower operates on PWM signal generated by Harmony. Harmony overrides blower speed taps. Blower speed varies according to zone demand.</p>	
<p>Harmony and Two-Speed Compressor</p>	<p>No Jumpers</p>	<p>Blower operates on PWM signal generated by Harmony. Harmony overrides blower speed taps. Blower speed varies according to zone demand.</p>	