

CORROSION AND PROTECTION

Objectives:

This module will provide gas distribution engineer with an understanding of basic corrosion concept that will include the common terms in corrosion control engineering.

At the end of the module the gas distribution engineer will have a fundamental knowledge on corrosion control for gas pipeline system. The knowledge gain will allow the gas distribution engineer able to apply the requirement of corrosion engineering for a pipeline system on corrosion control and its related operation and maintenance in preventing the gas pipeline from corrosion.

The participants who have some basic knowledge relating to chemistry, basic electrical and metallurgy shall be more advantage.

MODULE OUTLINE

1.0 Introduction to Corrosion

- 1.1 Definition of corrosion
- 1.2 Cost of Corrosion
- 1.3 What is Corrosion?
- 1.4 Why metal corrode
- 1.5 Concept of Corrosion
- 1.6 Corrosion Process
- 1.7 What Must a Corrosion Cell have?
- 1.8 Effect of Current Flow on Corrosion
- 1.9 What Damage Corrosion Caused
- 1.10 Environment of Corrosion
- 1.11 Classifications of Corrosion

2.0 Coatings

- 2.1 Classification of coatings
- 2.2 Principle of corrosion protection by organic coating

3.0 Paintings

- 3.1 Introduction
- 3.2 Principle of protection
- 3.3 Component of Paints
- 3.4 Paints classifications

4.0 Cathodic Protection

- 4.1 Introduction
- 4.2 The Corrosion Process
- 4.3 Principle of Cathodic Protection
- 4.4 Criterion for Cathodic Protection
- 4.5 Factors to Be Considered For the Application of Cathodic Protection
 - 4.5.1 General
 - 4.5.2 Coatings
 - 4.5.3 Electrical Continuity
 - 4.5.4 Isolation
- 4.6 Practical Applications of Cathodic Protection
 - 4.6.1 General
 - 4.6.2 Galvanic Anodes
 - 4.6.3 Impressed Current System
 - 4.6.4 Comparison of Galvanic Anode and Impressed Current Systems

5.0 Onshore Cathodic Protection Design

- 5.1 Soil Survey
- 5.2 Current Density
- 5.3 Determination of Cathodic Protection System Type
- 5.4 Galvanic Anode System Design
- 5.5 Impressed Current Cathodic Protection System Design
- 5.6 Special Considerations for onshore Cathodic Protection

6.0 Cathodic Protection Equipments and Maintenance

- 6.1 General
- 6.2 Transformer-Rectifiers

- 6.3 Sacrificial Anodes
- 6.4 Impressed Current Anodes
- 6.5 Backfill
- 6.6 Insulated Flange and Isolating Joints

7.0 Specialized Pipeline Surveys

- 7.1 General
- 7.2 Close Interval Potential Survey (CIPS)
- 7.3 Signal Attenuation Coating Survey (SACS)
- 7.4 Pearson Type Coating Survey
- 7.5 Direct Current Voltage Gradient Survey

8.0 Conclusion

9.10 References and Suggested Additional Reading

- i) British Standard Code of Practice for Cathodic Protection C P7 1
- ii) Cathodic Protection by John Morgan
- iii) Control of Pipeline Corrosion by A.W. Peabody.

1.0 INTRODUCTION TO CORROSION

1.1 Definition of corrosion

The corrosion of a metal is the destruction because of its reaction with its environment. Corrosion of metals will cause metal loss by conversion from the elemental state to the chemically combined state by oxidation. Corrosion process can be fast or slow. The corrosion process affects adversely on the preserved properties of metal.

Railroad track usually show slight rusting - not sufficient to effect their performance over many years.

Delhi Pillar in India was made almost 2000 years ago and is almost as good as new. It is 32 ft. height and 2 ft. in diameter - exposed mostly to dry condition.

Corrosion in the oil field appears as leaks in tanks, casing, tubing, pipeline and other equipment, this is due to base metal disappears as corrosion changes it to another type of material.

1.2 Cost of corrosion

Estimate of annual cost of corrosion in the U.S. vary between USD6- USD126 billion. Authors' Professor and Chairman Emeritus Department of Metallurgical Engineering Fontana Corrosion Centre OSU quote that the cost of Corrosion in U.S. is USD30 billion per year, U.S. Department of commerce stated "Corrosion will cost the United States an estimated USD126 billion in 1982" Annual U.S. costs for:

	1970	1980	1982
CORROSION	15 billion	20 billion	126 billion
FIRE DAMAGE	10 billion		
AUTO ACCIDENTS	20 billion		
WIND DAMAGE	1 billion		

The cost of metallic corrosion in the US in 1975 the annual direct & indirect cost of corrosion were estimated to be USD70 billion 4.2% Gross National Product. U.S.A. National Bureau of standards has reported that 40% of U.S. steel production is used to repair or replace items rendered useless by corrosion. Sixteen cents on every barrel of crude oil was spent on corrosion loosed before corrosion control was implemented.

1.3 What is Corrosion?

- Destruction or deterioration of metal because of reaction (chemical or electrochemical) with its environment.
- Cause the loss of metal by conversion from element state to chemically combined state.
- Destruction by physical means is not a corrosion: e.g. erosion cracking, wear, fatigue, etc.
- Physical destruction accompanied by/and corrosion reaction: erosion-corrosion, corrosion wear, stress corrosion cracking, corrosion fatigue, etc.

In Great Britain a ton of steel corrodes every 90 seconds. In 1965 and 1972, Canadians bought more than 7 million automobiles- 60% of these new vehicles were scrapped because of corrosion.

Assuming at the same basis of percentage of GNP, Malaysia corrosion cost in 1996 (per capita GNP RM 11 Billion) is RM 462 Million.

1.4 Why Metals Corrode?

A metallic will be extracted from its ores (compound). Energy is required to release the metals from its original compound state resulting the metallic less stable.

It is a natural consequence that the metal will return to its more stable state through a corrosion process.

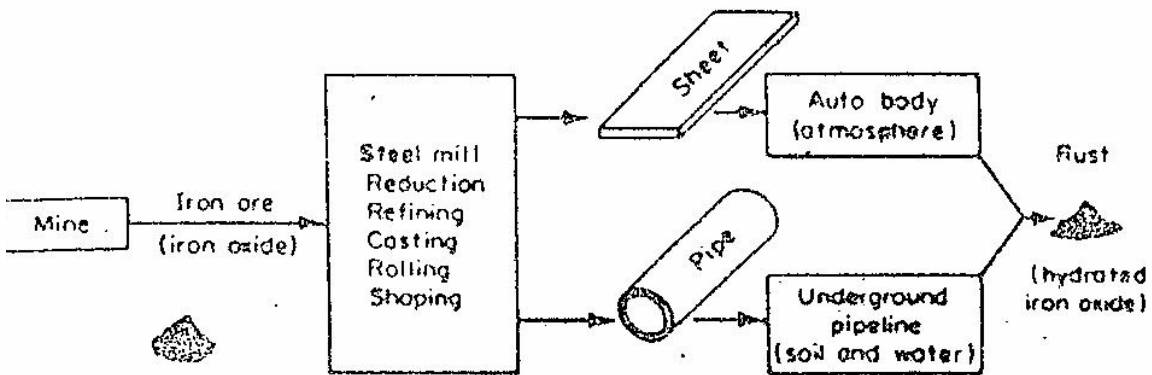

Fig. 1 Metallurgy in reserve

The difficulty of extracting metals from their ores in terms of the energy required, and the consequent tendency to release this energy by corrosion varies from metal to metal and is reflected by the relative positions of pure metals in 'Electromotive series'.

Most	Potassium (Active End)	-2.922 (std.potential volt)
Energy	Magnesium	-2.34
	Aluminum	-1.67
	Zinc	-0.762
	Chromium	-0.710
	Iron	-0.440
	Nickel	-0.250
	Hydrogen	-0.000
	Copper	-0.345
	Silver	+0.800
	Less	Platinum (Noble or
Energy	Gold Passive End)	+1.680

Position of some metals in the Standard Electromotive (EMF) Series

The above standard EMF series is precisely measured between metals exposed to solutions containing approximately one gram atomic weight of their respective ions at a constant temperature 25°C versus hydrogen electrode. However in real life galvanic coupling between metals in equilibrium (EMF series) with their ions rarely occurs or most engineering metals are alloys. Hence galvanic series is more practical series to be used. It agrees closely with their constituent elements in the EMF series.

1.5 Concept of corrosion

The corrosion process is an electrochemical process by which reaction proceed by an oxidation or (dissolution) reaction, and a reduction or (deposition) reaction. All corrosion process involved anodic reaction and cathodic reaction. The oxidation, or anodic reaction takes and the reduction or cathodic reaction occurs on cathodic of the structure. The anode is at a more negative electrochemical potential and is said be more active than the cathode. The potential difference between the anode and cathode provides the driving force for the corrosion reaction.

Anodic and cathodic sites exist because of several factors for example:

1. Where **dissimilar metals** are in contact, the metal with a more negative potential becomes the anode and that with the less negative becomes the cathode.
2. **Differential concentration**, where a one metal immersed in an electrolyte suffers due to local concentration differences e.g. salt, in the solution.
3. **Differential aeration**, where a metal is immersed in an electrolyte having a different local oxygen level. In this case, the metal end immersed in the low oxygen content becomes the anode and that in the high oxygen content region becomes the cathode.
4. **Dissimilar temperature** where metals are at different temperatures that will create a thermo galvanic potential differences.

1.6 Corrosion process

In general all corrosion processes is an electrochemical but not every electrochemical process is a corrosion process.

e.g : Rusting of iron

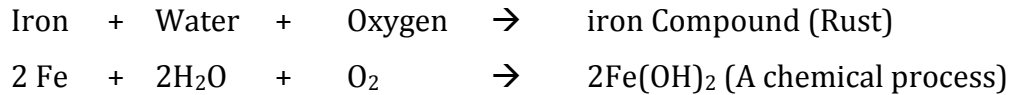

At Anode / Oxidation:



The anodic reaction is indicated by an increase in valency, a release of electrons or consumption of metal

At Cathode / Reduction :



While the cathodic reaction is shown by a decrease in valency, a consumption of electrons or deposition of metal species.

From the above, the corrosion process involves oxidation and reduction at the anode and cathode respectively.

Many types of anodic reactions (50 – 60% of metals) that lead to a soluble product that promote the corrosion to continue or a solid product non-soluble that may prevent a further corrosion process. Whereas in aqueous environment at cathode, reduction of Oxygen is very common type as cathodic reaction compared to evolution of Hydrogen.

Therefore, by controlling either or both cathodic and anodic process means controlling corrosion.

1.7 What Must a Corrosion Cell have?

Before proceed any further, it is essential to highlight the necessary conditions which must be met before a corrosion cell can function

They are;

- a) There must be an anode and a cathode
- b) There must be an electrical potential between the anode and cathode. (This potential can result from a variety of conditions on pipelines)
- c) There must be a metallic path electrically connecting the anode and cathode (Formally, this will be the pipeline itself)
- d) The anode and cathode must be immersed in an electrically conductive electrolyte which is ionized – meaning that some of the water molecules (1-120) are broken down into positively charged hydrogen ions (H⁺) and negatively charged hydroxyl ions (OH⁻). (The usual soil moisture, or water, surrounding pipelines normally fulfills this condition).

Once these conditions are met, an electric current will flow and metals will be consumed at the anode.

1.8 Effect of Current Flow on Corrosion

The amount of metal that will remove is directly proportional to the amount of current flow. One ampere of direct current discharging into the usual soil electrolyte can removed twenty pounds of steel in one year (i.e. approx 9kg/A.yr). This is based on the electrochemical equivalent of the metal involved; other metals than steel will be removed at other rates, some more and some less.

For steel, 1 ampere of current flow may only dissolve 5 micron of steel if for example, it is uniformly over 1.0 km of 30 inch diameter pipe over 10 years period.

However, if this current is confined to an area of about 20 mm diameter of similar pipe of 16 mm wall thickness, perforation could occur within about 4 hours.

1.9 What Damage Corrosion Caused

The corrosion damage causes many deterioration effects such as;

i) Appearance

Corrosion causes a material such as automobile turns less impressive, a building look dull. This eventually results in the loss of economical value of the materials

ii) Maintenance and Operation Costs

Due to corrosion, more maintenance and operation costs which will incur into the entire operation, such as chemical plant and refinery. Better and expensive materials may be required more work force will be necessary and even extra tool or equipment may be needed.

iii) Plant Shutdown

Plant shutdown causes by corrosion which is usually and will always be the most unwanted incident. Plant shutdown may directly cause less of production and indirectly because the negative image of one's reputation when products or services are not delivered in time. This will be even obvious when the plant shutdown is caused by unexpected corrosion failures.

Regular inspection on the corrosion status of a plant, together with the proper implementation of monitoring system are two most helpful ways in preventing unexpected corrosion failure and plant shutdown.

iv) Contamination of Products

This effect will most costly when it evolves the products which the market value is very much depending on their purity and quality. E.g. Palm oil, foods, drugs, pigments, semiconductors and transparent plastics.

v) Loss of Valuable and Dangerous Products

Oil pipeline leakage can cause environmental pollution as well as loss of money. Furthermore, leakage of highly flammable products such as gas can result in per critical.

vi) Effect on Safety Reliability

Corrosion on bridges and jetties can result in catastrophic failure. Vibration together with corrosion can cause the aerospace vehicles to fail un-expectedly. Therefore, corrosion can cause a structure to be unsafe and unreliable.

vii) Product Liability

Corrosion may happen unexpectedly thus may not anyone's responsibility. Therefore, if failures are caused by corrosion, it would be difficult in solving the liability through legal responsibility. Eventually a party will need to spend extra fund for the unexpected damages due to corrosion.

1.10 Environments of Corrosion

1. Atmospheric

- a. Indoor- Controlled environment e.g. humidity, ambient temperature.
- b. Rural - Away from Industry, sunshine, rain, Oxygen, CO₂, chemical.
- c. Marine - High humidity, salts, more rain, NaCl.
Corrosion could be 300 times as severe as rural environment.
- d. Industrial – Acid rain e.g. SO₂, HCl, N_xO_x plus CO₂

2. Underground corrosion / soil corrosion

Soils can be considered as an aqueous electrolyte that varies widely in physical and chemical characteristics and in their corrosivity towards metals. They consist of a multiphase system of inorganic components, i.e. natural rocks and minerals and also organic components i.e. humus materials. These combinations control water percolation rates, water retention, oxygen content, electrical conductivity of a material is determined by several factors including resistivity, pH, oxygen content, aggressive ion concentration and microbial activity, the type of soil and its constituents, as the medium on contact with a buried metal will control the corrosion.

Factors Affecting Corrosivity of the Soil

Underground corrosion in a soil is another form of corrosion and is therefore an electrochemical process. Thus, when two points, which are electrically connected and immersed in an electrolyte (i.e. the soil) have a difference in potential, there will be a flow of current from the

metal termed the anode are (the most negative) through the electrolyte (soil) to the cathode area (the most positive) then via the metal to complete the circuit. The metal is dissolved in an anodic reaction and species from the soil (e.g. O_2) is consumed at an equivalent rate in a cathodic reaction. The electrical current flow in the cell is by electron transfer in the metal and ion transfer in the soil. The electrochemical process in soils involves many complicated and difficult factors.

Soil characteristic very variable e.g. water table, resistivity, aeration, bacteria, soluble minerals (salts), moisture, compaction and temperature.

3. High temperature corrosion

When a metals/alloys is oxidized at elevated temperatures greater than about 400°C , a stable oxide or other compound generally covers and “coats” the exposed metal surfaces. The product layer may acts a barrier between the under laying metal and the corrosive environment. However, in industrial practice, alloys are rarely exposed to pure oxygen but instead environment is more variable and complex. For example, many sources of energy and raw materials for chemical, metallurgical and power-generation industries are hydrocarbon fuels e.g. oil, gas, coal that containing impurities such as S or Cl hence, atmospheres can contain mixtures of O_2 , N_2 , H_2 , H_2O , CO , CH_4 , H_2S , SO_3 , SO_2 , NH_3 , C, S_2 , HCl , etc. in a wide range of concentrations and pressures. As the results, e.g. oxidation, carburization, sulphidation, chlorination and nitridation. In addition, molten products and / or deposits that will cause hot corrosion

problems due presence of high concentration of Na, K, S, V-alkali metals during combustion.

1.11 Classifications of corrosion

Corrosion can be classified in many ways. Some classifications categories corrosion into low temperature and high temperature corrosion. However, the more general and preferred classification is wet corrosion and dry corrosion. Wet corrosion is an aqueous solution (i.e. electrolyte) corrosion process that occurs in the presence of a liquid. This aqueous solution can exist either as a bulk solution, or as droplets or a moisture layer on the metal surface. This type of corrosion is very common and the major contributor to the corrosion problem. A common example of this type of corrosion is steel in sea water. In contrast to wet corrosion, dry corrosion occurs in the absence of a liquid phase or above the dew point of the environment or a gaseous environment. This type of corrosion is often associated with high temperature, and is normally termed oxidation (if it occurs in a gas containing oxygen) or sulphidation (in gas containing sulphur) or hot corrosion (if molten salts are present).

Corrosion may classify based on the **morphology of attack**. Thus, localized corrosion is associated with inhomogeneities in the metal phase or its environment, resulting in attack on small areas or spots on the metal surface. Uniform or general corrosion occurs more evenly over a surface and can often be permitted if its rate is low enough so that the thickness of the metal structure is still sufficient to function for the design lifetime. In contrast localised corrosion frequently happens with small metal loss but with severe damage due to perforation at pits or due to cracking.

2.0 COATING

The protection of a structure can be achieved by preventing or controlling the processes of the anodic and cathodic reactions. Application of a coating is one of the methods that are widely used to control corrosion.

2.1 Classification of coatings

Coatings are widely used for the protection of structures. The types of coatings mainly depend upon the method of coating, the suitability of the environment and the type of structures to be protected. Very thin coatings are suitable for the structures where physical and abrasion resistance is not essential whereas, the application of very thick and tough coatings are necessary for structures where maintenance is a problem and protection against the environment is very much required. Therefore, the selection of a suitable material and type of coating are very important for buried pipelines which are difficult in both maintenance and in requirements against the soil environment.

Typical coatings for buried pipelines range from hot-applied coal tar or petroleum asphalt-base-filled enamel, in the form of tape application i.e. Polyethylene and polyvinyl chloride, to epoxy types that are extruded onto the pipe surface. However, coatings inevitably have flaws and defects. Thus, to reduce this shortcoming a combination of coating with cathodic protection is applied. Thus, the coating also should have specific properties required for the both systems to work together due to the chemical reactions which are taking place at both the anode and the cathode during cathodic protection current flow.

2.2 Principle Of Corrosion Protection By Organic Coating

The coating shields the structure from the corrosive environment and cathodic protection ensures that bare-metal defects in the coating are protected. The most general corrosion protection mechanism is due to the barrier effect of the coating. The efficiency of the barrier effect depends on

1. The permeability of the coating to water and water vapour.
2. The permeability of the coating to oxygen.
3. The permeability of the coating to ions.
4. The electric resistance of the coating (which is related to 3)

Absorption of water by organic coatings is related to the concentration of water in the electrolyte (environment). There evidence shows that, the coatings are generally very permeable to water and oxygen. Water permeability in a coating is controlled by the concurrent process of water absorption and diffusion. Different types of coatings have different polymeric structural features like polymer polarity, crystallinity, cross linkage and chain - stiffness which are very important in determining the amount of absorbed water and diffusivity of water. The presence of defects such as pores, holidays and fissures, will allow water to be absorbed easily and will start corrosion on the metal underneath the coatings. The amount of water and oxygen penetrating through a coating, even without defects, is believed to be enough to initiate corrosion on the underlying metal.

In the case of coatings containing active pigments, the corrosion products produced i.e. zinc oxides, hydroxides and carbonates may fill up the pores of the coating and create a barrier to the movement of oxygen and water. In the presence of inhibitive pigments in the coatings, the corrosion is controlled by suppressing the rate of anodic and cathodic reaction either individually or together. Thus, a possible parameter which may contribute to corrosion control by an organic coating is its d.c.

resistance. A high d resistance, i.e. greater than 10^8 Ohm-cm^2 , is required for a good protective coating. Thus, even coatings without inhibitive or active pigments still can limit corrosion by inserting a high electrical resistance component between the anode and cathode. It is generally believed that the electrical current across organics coatings consists of a flow of ions. Thus, the electrical resistance of coatings is controlled by a mechanism of ionic permeation through the coatings. Also, coatings when immersed in electrolyte will take-up a charge. Most coatings contain the carboxyl group, which may be selectively permeable to cations. The ions permeate through coatings by an ion exchange mechanism. Thus, the electrical resistance of immersed coatings may slowly change with increasing ion exchange between the cations from the electrolyte and hydrogen ions from the carboxyl groups in the coatings. It was shown that coatings with high ion exchange capacities show poor corrosion protection, whereas those with low ion exchange capacities show better corrosion protection to the underneath metal. Therefore, it can be concluded that coatings of normal thickness are permeable to water and oxygen and do not prevent corrosion by controlling the diffusion of these species. However, corrosion is restricted by interposing a high electrical resistance between the cathodic and anodic site. Thus, the electrical resistance of a coating film is controlled by the mechanism of ionic permeation or diffusion through the films.

3.0 PAINTINGS

3.1 Introduction

The purpose of paint beside good decorative properties & colour retention is to provide long lasting protection from corrosion resistant to chemicals and weathering.

3.2 Principal of protection

Painting is used as one of the method employed to prevent the above ground pipelines from corrosion. Mainly there are 3 main principles methods employed:

- a) Create a barrier that keeps out charged ions and retards the penetration of water and oxygen which is called Barrier effect.
- b) Ensure that water, on its passage through the paint coating, takes up special compounds inhibiting its corrosive action that called Inhibitor effect.
- c) Ensure metallic contact between the steel and a less noble metal e.g. zinc. This affords cathodic protection of the steel by utilizing the Galvanic effect

3.3 Component of paints

Generally paints consist of a liquid and solid portion:

1. Binder
2. Pigment
3. Extender
4. Solvent
5. Thinner
6. Additive

4.0 CATHODIC PROTECTION

4.1 Introduction

Cathodic protection is an electrochemical method of preventing external corrosion of buried or immersed metallic structure which in practice include pipelines, tank bases, steel jetties, offshore platforms and ship hulls. In addition technique is used to protect the internal surfaces of tanks and pipelines storing or transporting corrosive liquids.

In recent years the technology of cathodically protection steel reinforcing in concrete has been developed. However, although the principle is identical, the application and engineering design factors are rather different.

For the purposes of this section of the course the cathodic protection of an onshore buried pipeline is primarily considered.

In order to explain practical cathodic protection application, a brief mention is made of coatings and other factors which effect cathodic protection design.

4.2 The Corrosion Process

Corrosion occur the surface of a metal as a result of current flowing in a corrosion cell. The difference in potential between an anode and a cathode will cause current to pass electronically in metal and ionically in surrounding electrolyle. In both cases, electrons pass and it is in the trans of these electron across the steel/electrolyte interface that corrosion occurs. This system can be represented in the following simple circuit:

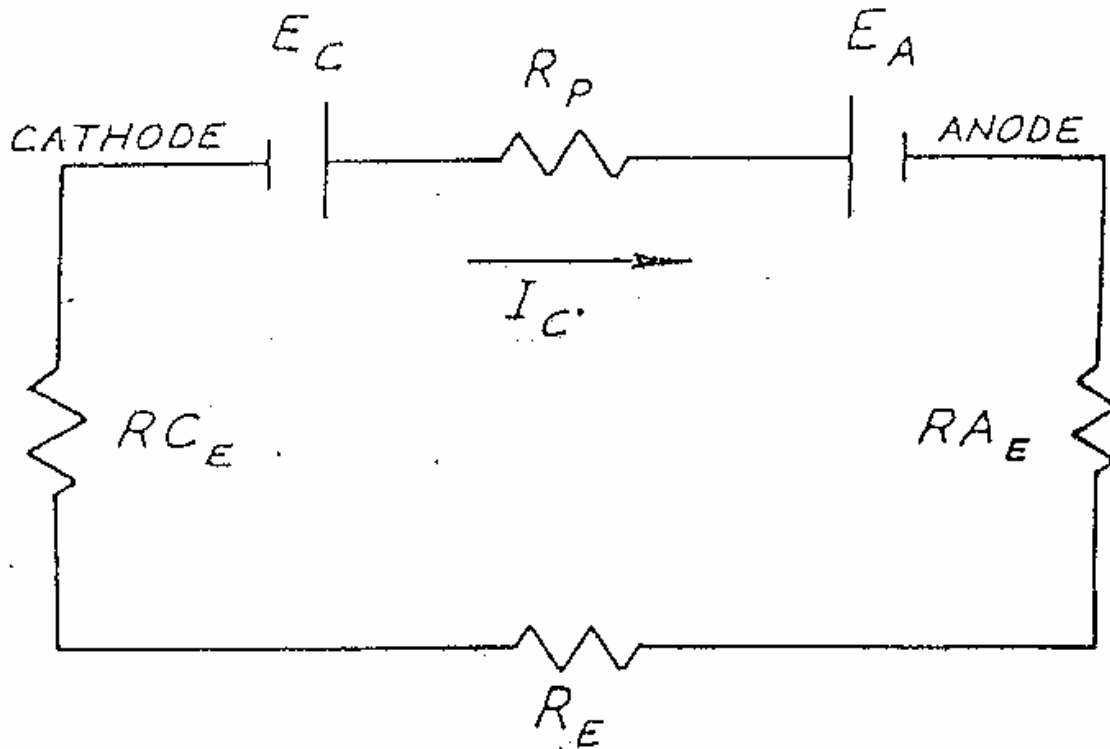
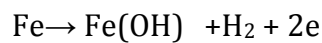
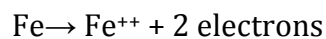

Figure 1 Corrosion simple circuit

Using Ohms law, the net corrosion EMF ($E_c - E_a$) equals the product of the sum of the circuit resistances and the corrosion current flowing (I_c). Given that the actual corrosion process iron in its crystalline or solid elemental state converting to soluble iron ion with the release of electrons thus:



Involves the flow of electric current (the passage of electrons)- then corrosion control processes are those which either INCREASE the resistance of the circuit or reduce the net potential or driving voltage of the circuit: The corrosion occurring is directly proportional to the corrosion current (I_c) in the circuit.

The corrosion EMF ($E_c - F_a$) may be produced by bimetallic contacts, ruptured mill scale, differential aeration, steel in concrete, bacterial action, etc. R_p , the resistance of this metal circuit between anode and cathode is of great significance when the anode and cathode are physically remote; long line corrosion, stray current effects and certain differentials in the soil apply in this case. R_E is the resistance of the electrolytic circuit between anode and cathode and this is of particular importance when anode and cathode are close by. The resistance of any element is related to specific resistance by:

$$R = \frac{\rho L}{A}$$

where ρ = specific resistivity, A = cross sectional area and L is length. When anode and cathode are remote, A approaches infinity so that this factor may be neglected.

R_{AE} and R_{CE} are the resistances of the electrodes to earth and these are very easily influenced. In the instance, they are the polarisation resistances and in the second case they may be largely a function of the soil resistivity, or of any other barrier such as films of molecular thickness formed by a corrosion product or by artificially produced film of high resistance (coatings) on the pipe surface.

The severity of corrosion, then, will depend on the current flow and the anode area. Iron goes into solution at the rate of some 9kg per ampere-year. Thus a current of 1 ampere may only remove 5 micron of steel if, for example, it is uniformly spread over 10km of 30 inch diameter pipe over a ten year period. If confined to an area of about 20mm diameter of similar pipe of 16mm wall thickness, perforation could occur about four hours.

4.3 Principle of Cathodic Protection

Corrosion cells develop on the same piece of metal for the various reasons and thus, the corrosion current flows due to a potential difference between the local action

between the best action anodes and cathodes. As the result corrosion occurs at the ANODES which are consumed while the CATHODES remain intact. The objective of cathodic protection is to ensure that the whole of the metal pipeline to be protected is the CATHODE.

In a larger cell the anode of which is separate and renewable but using the same electrolyte (soil). Schematic diagrams assist in understanding this concept:

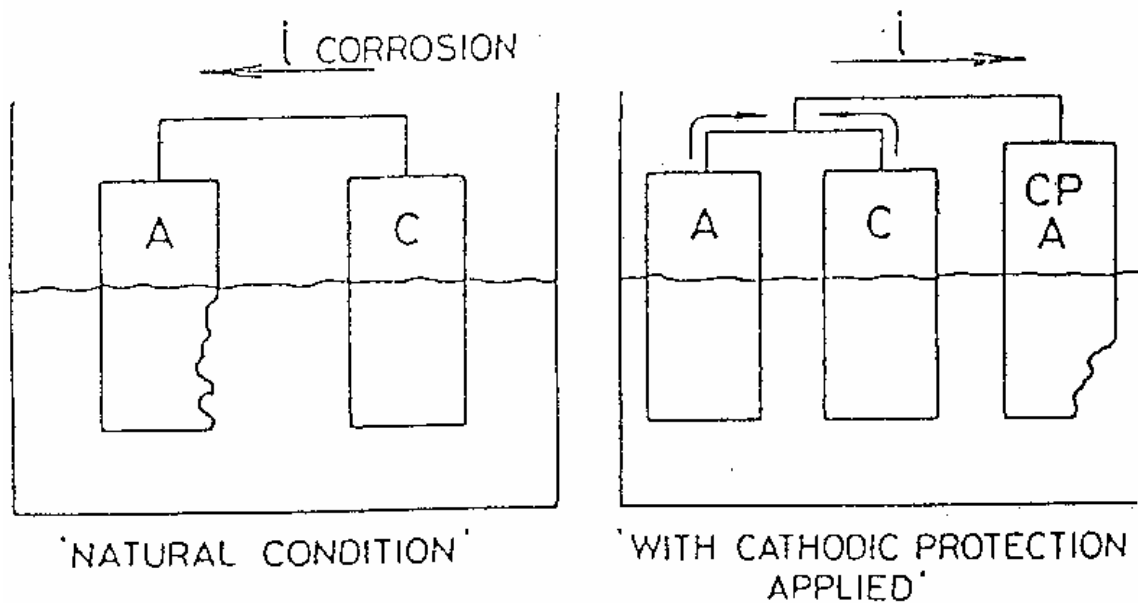
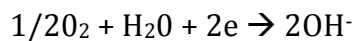

Fig. 2 Schematic diagrams concept of cathodic protection

All the pipeline metal now behaves as a cathode so that the reaction of anodic reaction cannot proceed and is replaced by the cathodic reaction.



Redrawing the earlier circuit diagram

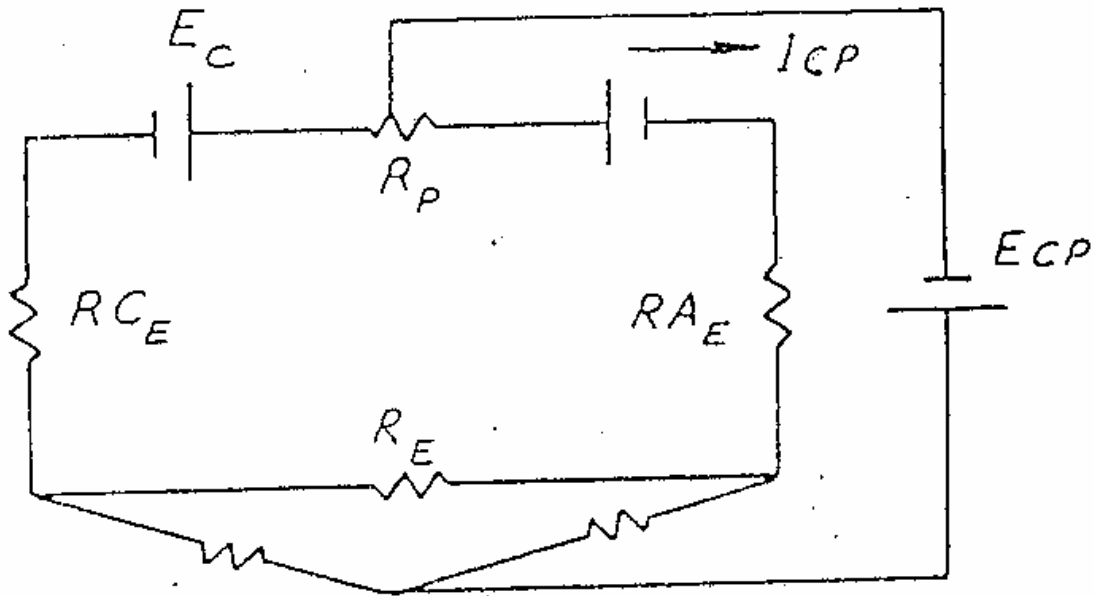
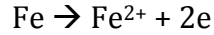

Fig.3 Application of Cathodic Protection

At this stage, it is necessary to clarify some terminology. The passage of electric current is the movement of electrons. In a metallic conductor, current is regarded as flowing in the opposite direction to the movement of electrons so that in the pipe or cable, current flows from the cathode to anode. In soil or water, it is the movement of ions which provide q and it is conventional to refer to 'current' as flowing from anode to cathode. Thus, on a corroding pipe, current flows off the pipe at the anode into the soil while at the cathode, current flows from the soil onto the pipe.

Cathodic protection then, depends on current flow onto the corroding surface from the surrounding soil. It follows, therefore that the current must have a path available from the CP anode to the metal through the same electrolyte. This that cathodic protection cannot be applied to structures unless they are buried or immersed. An example would be an over-ground section of a pipeline or a fitting in a valve pit where the corroding electrolyte is merely a film on the surface of the steel. At this stage, also, it is useful to examine the term 'potential' which will be used so often in cathodic protection.

You will recall how we showed the electron movement with iron tending to go into solution.



This is a reaction which will always attempt to occur in solution. The pressure of the reaction is measurable as a voltage which can be termed 'solution potential'. Like all things, standards are available to measure this and the one commonly used because of its stability and ease of reproducibility is copper. Copper, immersed in a solution already containing as many ions of copper (in the form of copper sulphate) as will dissolve at normal temperatures, will always have same potential.

Thus, if we wish to measure the solution potential of a metal in an unknown solution we can couple it with the copper potential measure it and have the answer by difference.

Metal/Electrolyte//Copper Sulphate/Copper

All that is necessary to have the copper contact the same electrolyte as the metal while remaining in an immediate environment of copper sulphate.

This is a very useful tool since the solution potential indicates the TENDENCY (but NOT the RATE) for the metal ion to go into solution. Let us look at a few examples: (We will not deduct the copper potential since it will be standard throughout: the potentials will be compared and simply 'referred to Copper/Copper Sulphate').

Steel in near neutral soils exhibits a solution potential of between -0.5 and -0.7 volts. When we measure this on a pipeline, we use the term **pipe to soil potential**. A reactive metal such as magnesium, however, exhibits a solution potential of as much as -1.5 volts referred to Copper Sulphate.

On an unprotected pipeline, local anodes may show a potential of -0.8 volts while elsewhere on the same metal surface, local cathodes may show a potential of -0.4 volts.

We have described cathodic protection as a means of converting the whole pipeline to cathode. In order to do this, we must **eliminate the differences in potential between the local anodes and cathodes and we tend to drive all the potentials numerically upwards (make them more negative).**

It can be shown theoretically, from a consideration of the electrochemistry of that reaction anodic reaction that when steel reaches a solution potential of 0.85 volts referred to copper sulphate, this reaction cannot proceed, and were it reversible would tend to go backwards. The efficiency of 0.85 volts derived theoretically as the protective potential of steel in near neutral soils or water has also been demonstrated experimentally. However, for this reason, and the necessity to cater for the particular case of active sulphate reducing environment), the practical figure of 0.95 volts is often specified. The method of measurement of pipe to soil potentials is shown in the following diagram.

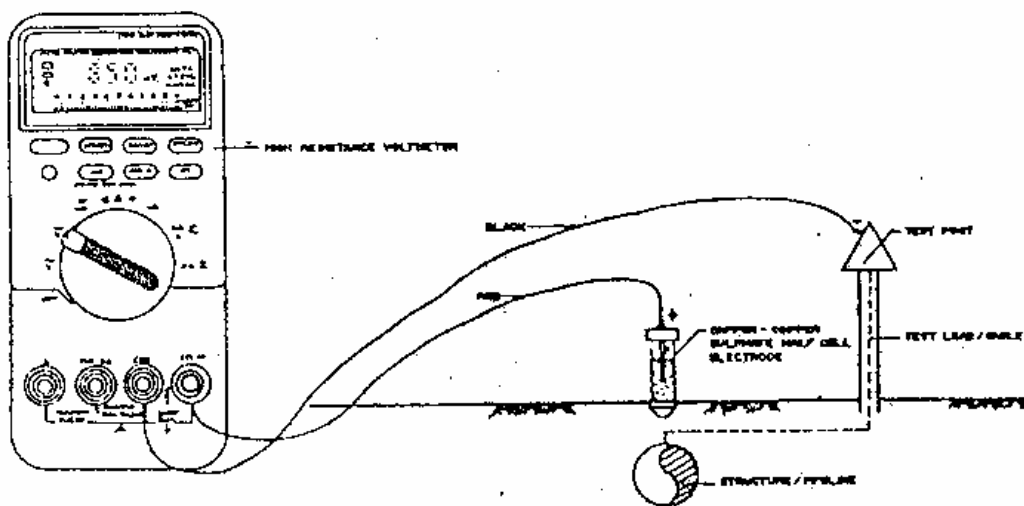

Fig. 4 Method of measurement of pipe/soil potential

4.4 Criterion for cathodic protection

A minimum criterion for the measurement of complete protection on buried pipelines is needed by corrosion engineer to ensure the buried pipeline is protected. Based on practical application, several criteria have been proposed and used particularly those in NACE standard for underground or submerged steel and cast iron structures. These criteria are as follows:

1. In **aerobic environments** a potential of at least -0.850 volts as measured between the structure and a copper-copper sulphate reference electrode contacting electrolyte, is usually recommended. In **anaerobic environments** a potential of -0.50 volts needs to be considered due to the possibility of microbial action.
2. Adequate protection can be achieved when the structure potential shift or 'swing' is of at least -0.3 volts versus copper-copper sulphate. Determination of this potential swing is to be made with the protective current applied. This criteria of potential swing applies to a structure not in contact with a dissimilar metal.
3. A minimum negative (cathodic) polarization potential of the structure shift of 100 mV versus copper-copper sulphate contacting the electrolyte. This polarization potential shift is to be determined by interrupting the protective current and measuring the polarization decay. When the current is initially interrupted, an immediate potential shift will occur.

4.5 Factors to Be Considered For the Application of Cathodic Protection

4.5.1 General

Before applying cathodic protection to a metallic structure, several factors need to be considered in order to ensure that protection can be effective.

4.5.2 Coatings

Coatings are applied to metallic structures in order to provide corrosion protection. Referring back to figure 1 the resistances of the electrodes to earth RA_E and RC_E can be controlled by the use of coatings, i.e. by increasing these resistances the corrosion current will be reduced.

A coating increases the resistance of a structure to the electrolyte by reducing the area of metal exposed. To be effective a coating must have certain properties i.e. it must be continuous, have a high electrical, chemical, bacterial and abrasion resistance, temperature tolerance, good aging characteristics and must strongly adhere to the surface of the structure.

No coating is ever perfect, there will always be gaps 'holidays' however by **reducing the area of metal exposed to the electrolyte the current requirement (overall current density) for cathodic protection is reduced.** If a coating is 99% effective the cathodic protection current demand will be 1% of that required to protect the same structure without a coating.

4.5.3 Electrical Continuity

In order to cathodically protect a structure it must be electrically continuous to ensure the complete structure becomes cathodic. If a

structure is not continuous by virtue of it's construction (e.g. welded), continuity can be achieved by the use of cable bonds.

On a structure which is not electrically continuous, part of the protection 'current may pass through isolated sections of the structure, in this situation current may flow out at one point and be discharged at another causing accelerated corrosion at the discharge point. This principle is dealt with in more detail in sect. 6.6.6(e).

4.5.4 Isolation

The design of a cathodic protection system must be based on a defined structure, which is to be protected. This must then be electrically isolated from any other buried or immersed metal. For example a pipeline must be separated from other plant at each end. Isolation is required to avoid current draining to other structures which at best will result in a larger than necessary current demand and at worst prevent protection being achieved at all.

It is particularly important to **isolate steel structures** (pipelines, tanks etc.) **from copper earth systems**. Copper is electro-positive to steel and drains cathodic protection current preferentially resulting in very large current demands.

4.6 Practical Applications Of Cathodic Protection

4.6.1 General

Cathodic protection can be achieved in two ways by the (sacrificial) anodes or by 'impressed' current. Detail of the two methods are provided below.

4.6.2 Galvanic Anodes

Galvanic anode systems employ resolve metals as anodes connected directly to the steel structure to be protected. The, difference in n between the anode and the steel as indicated by their relative positions in the electrochemical series, causes a positive current to flow in the electrolyte so that the whole of the steel surface becomes a cathode.

Three metals are commonly used as sacrificial anodes: magnesium (principally used onshore), zinc (used both onshore and offshore) and aluminum (used offshore).

A typical galvanic system using magnesium anodes to protect a buried pipeline is shown in figure 5.

The link in the post may be used to measure the current flow and/or the pipe to soil potential. In soils magnesium anodes are commonly 10-20kg in weight, about 100mm diameter by 750mm long cylinders and provide current flow of between 10-500 mA, depending largely on soil resistivity. Anode metal consumption is directly in proportion to the current flowing. Magnesium for example, consumes at rate of 8Kg per ampere-y In practice, the use of sacrificial anodes is restricted to soil resistivities less than 10000 Ohm-cm (100 Ohm-metre)

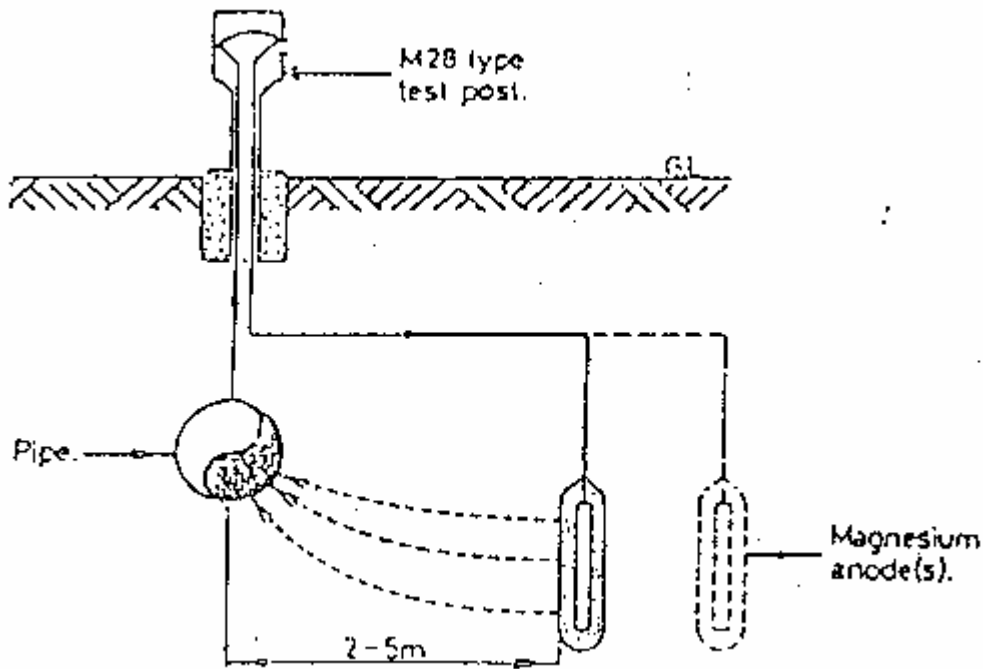

Fig. 5 Typical galvanic anode system

4.6.3 Impressed current system

Impressed current cathodic protection provides the voltage necessary to make the current to flow in the circuit by means of a D.C voltage source and of any expendible material as the anode. AC power E_s provided to the use transformer-rectifier which produces a terminal voltage of up to say, 48 volts. The negative pole is connected through the link box to the structure while the positive pole passes through very well insulated cables to inert anodes buried in soil. The anodes are conventionally buried in coke. Coke and graphite are non metallic in the sense that the passage of current does not dissolve them. Their deterioration is a function of other factors so that their life, for practical purposes, is in order of 10-20 years or more.

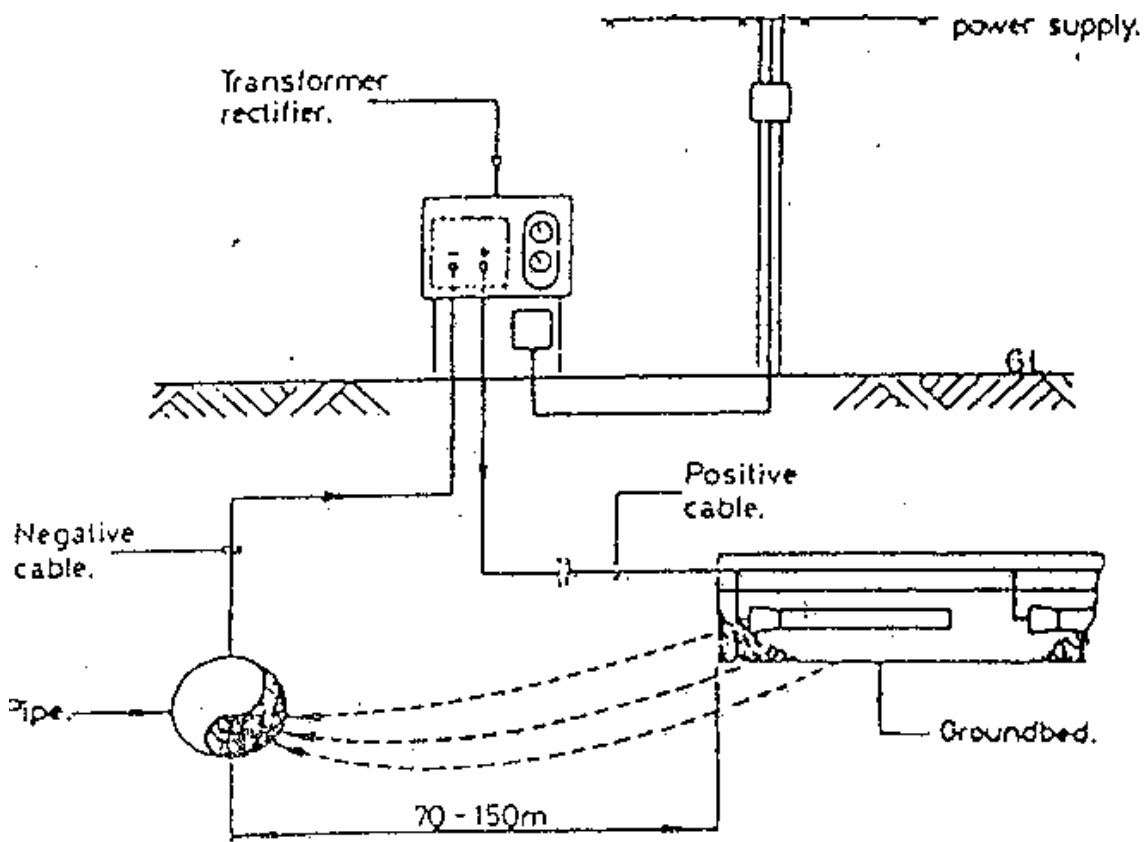

Fig 6 Typical Impressed Current Anode system

4.6.4 Comparison of Galvanic Anode and Impressed Current Systems

	Galvanic Anodes	Impressed Current
1	They are independent of any source of electrical power	Requires a mains supply or other source of electric power
2	Their usefulness is generally restricted to the protection of well-coated structures or the provision of local protection, because of the limited current that is economically available.	Can be applied to a wide range of structure including, if necessary, large uncoated structures.
3	Their use may be impracticable except with soils or waters with low resistivity.	Use is less restricted to the resistivity of the soil or water.
4	They are relatively simple to install, additions may be made until the desired effect is obtained.	Needs careful design although the case with which output may be adjusted allows for unforeseen or changing conditions to be catered for.
5	Inspection involves testing with portable instruments at each anode or between adjacent pairs of anodes.	Needs inspection at relatively few positions instrumentation at points of supply can generally be placed where it is easily reached.
6	They may be required at a large number of positions. Their life varies with conditions so that replacements may be required at different intervals of time at different parts of system.	Requires generally a small total number of anodes.
7	They are less likely to affect any nearby neighbouring structures	Requires the effects on other structures that are near the groundbed of protected

	because the output at any one point is low.	structures to be assessed but interaction is often easily corrected if necessary.
8	Their output cannot be controlled but there is a tendency for their current to self-adjusting because if conditions change such that the metal to be protected becomes less negative, driving e.m.f. and hence current increases. It is possible, by selection of material, to ensure that the metal cannot reach a potential that is sufficiently negative to damage coatings.	Requires relatively simple controls and can be made automatic to be maintain potentials within close limits despite wide variations of conditions. Since the e.m.f. used is generally higher than with galvanic anodes the possible effects of ineffective control or incorrect adjustment for example damage to coatings are greater.
9	Their connections are protected cathodically.	Requires high integrity of insulation on connections to the positive side of the rectifier which are in contact with soil or water: otherwise they will be severely corroded.
10	They cannot be misconnected during so that polarity is reversed.	Requires the polarity to be checked commissioning because connection, so that polarity is reversed, can accelerate corrosion.

5.0 Onshore Cathodic Protection-Design

5.1 Soil-Survey

- a) Identification of the factors governing the corrosion process:
Clearly the principal influences will be associated with the soil in which the structure is to be buried so that the factors associated with the soil must be identified at an early stage. These include:
- (i) Soluble Salt Content
 - (ii) Salt Content
 - (iii) Physical Nature
 - (iv) Acidity
 - (v) Organic Material Content
 - (vi) Water Content
 - (vii) Reducing Bacterial Activity

From this brief statement of the principal factors it is evident that the soil in which the structure is to be buried is the first area to be investigated for identifying corrosion process factors. However in the case of pipelines corrosion current may be introduced by external factors.

Railway traction currents may short circuit' back to the nearest sub-station through the pipeline producing an anode at the point nearest to the sub-station, while the same effect can be produced by adjacent cathodic protection systems in certain circumstances.

Buried pipelines may also be effected by currents induced from out of balance overhead electricity distribution systems, which could cause anodic areas and in very long pipelines, geo-physical currents have been measured.

In the case of steel, the commonest corrosion initiator of all is the corrosion potential set up by the difference between steel bearing intact millscale and steel with the millscale film disrupted.

b) Investigation in Practice

In the case of a proposed pipeline, the soil and other relevant conditions along the route should be investigated. A record of the principal factors described above should be made: representative soil resistivities and soil analysis should be carried out and obvious hazardous areas such as sea water inlets, peaty areas, tips, effluent discharge points, polluted land or water, areas containing carbonaceous waste (cinders), electrified railway crossings, parallelisms with overhead high voltage distribution schemes and other cathodic protection systems identified.

When using soil resistivity to indicate the probable corrosive effect of soils to bare steel or iron it is understood that corrosivity will also vary with soluble salts and water contents of the soils, however, a general correlation between soil resistivity and the aggressiveness of the soil, ignoring other factors, can be broadly made as follows:

Soil Resistivity	Nature of Soil
Less than 1000 ohm-cm	Highly aggressive
1,000 - 3000 ohm-cm	Aggressive
3,000- 10,000 ohm-cm	Mildly aggressive
Over 101000 ohm-cm	Unlikely to be aggressive

In general, soil types encountered can be classified as follows:

Sea water/salt sands	Less than 100 ohm-cm
Coastal soils	100-3,000 ohm-cm
Clays	1,000-3,000 ohm-cm
Sandstones and shales	Up to 30,000 ohm-cm

Coarse gravel, fine	Up to 100,000 ohm-cm
Sand and rock	and over

Noting however that these general resistivity values can be greatly reduced by local intrusions of salt water or industrial or agricultural pollution.

This information should also be obtained in the case of existing pipelines. However, for these, additional data on linear electrical continuity, resistance to earth and construction techniques should be sought. Direct measurement of coating quality, cathodic protection current requirement and remaining wall thickness is possible, and trial pits will provide visual corroboration of these findings.

5.2 Current Density

NACE quote the following information for the cathodic protection of steel in soil:

Uncoated Steel	→	10 – 30 mA/m ²
Poorly coated Steel	→	1 mA/m ²
Well coated Steel	→	0.03 mA/m ²
Very well coated Steel	→	0.003 mA/m ²

The variation between 10 mA/m² and 30 mA/m² for bare steel in soil is dependant on the soil resistivity with the lower figure being applicable in higher soil resistivities with an increase up to 30 mA/m² with decreasing resistivity.

5.3 Determination of Cathodic Protection System Type

Having obtained information on the soil in which the structure is to be buried, the structure itself must be analysed.

The primary parameter is the surface area to be protected. This must be assessed in conjunction with the applied coating system. Generally as stated in Section 6.5.4 galvanic anode system as applicable protecting small, well coated structures such as short pipelines and for the provision of local protection on larger structures.

Impressed current systems are normally utilized on larger structures where current demand will be significant.

It is common practice on long pipelines to provide temporary protection by means of galvanic anodes in low resistivity areas during the construction phase and until the permanent impressed current system is installed and commissioned. This is typically several months after the completion of pipe laying.

5.4 Galvanic Anode System Design

Having calculated the current requirement from the surface area, coating quality, soil resistivity, parameters anode type, weight and location must be determined for protection over the required life.

Except in very low soil resistivities, magnesium is the only practical material to use for the protection of buried structures.

Anode weight can be calculated from the following equation:

$$\text{Wt (kg)} = \frac{\text{Current (Amps)} \times 8766 \times \text{Life (Years)}}{\text{Capacity (Amp Hrs/Kg)} \times \text{Utilization Factor}}$$

Where

- i) Capacity is the current available per unit weight of the material. For magnesium the theoretical capacity is 2200 Amp Hours per Kg,

however as the material has an efficiency of 50%, a value of 1100 Amp Hrs/Kg must be used for practical purposes.

- ii) Utilization Factor relates to the point where the anode is consumed such that the remaining material is insufficient to provide the required current output. For magnesium in soil this point is reached at 85% consumed i.e. the utilization factor is 0.85.

Magnesium anodes are available in standard sizes so when the required weight has been calculated the size and number of anodes can be decided. Depending on the structure, and soil parameters it may be best to use a small number of large anodes or more smaller anodes.

Individual anode outputs can be determined from anode resistance R_a formula, the most commonly used for onshore anodes is the

Dwight I modified formula.

$$R_a = \frac{P}{2 \pi L} (\ln \frac{4L}{r} - 1)$$

Where:

- P - Soil resistivity (Ohm-cm)
 r - Anode radius (in cm)
 L - Anode length (in cm)
 R_2 - Anode resistance

From this formula the anode current is calculated from:

$$I_a = V_d / R_d$$

Where:

- V_d - Driving Voltage (volts)
 I_a - Current (Amps)

The current obtainable from the anode(s) should then be cross checked against the total current requirement.

5.5 Impressed Current-Cathodic Protection System Design

a) Introduction

Several factors need to be considered when locating and designing onshore impressed current cathodic protection groundbeds in order to provide satisfactory long term protection to buried structures.

b) Groundbed Location

The single most important factor for groundbed location low soil resistivity site will enable a low resistance groundbed to be constructed with a minimum of material and installation costs.

On long pipelines the maximum separation between groundbeds is dictated by the current spread available from a groundbed site which is determined by pipeline resistance, coating condition and potential requirements, see section below.

d) However, working within the maximum spread normally allows a significant distance along the pipe route to be considered for groundbed location.

On fixed structures such as piling, tank bottoms etc there may be very little flexibility in groundbed location, however, soil resistivity can vary over short distances.

Other factors to be considered are as follows:

- e) **Power Supply**

Available AC power supply will enable a transformer- rectifier to be used. In remote areas alternative power sources can be used such as solar power, or generators but these options are a great deal more expensive than using an AC supply and if possible groundbeds should be sited to make use of it.

- d) **Remoteness**

Groundbeds should be at least 100m away from 1.he.s which is to be protected and as far as possible (minimum 300mjjrom other buried metallic structures. It is most important that a foreign service does not short circuit the groundbed i.e. pass close to it and then to the protected structure.

- e) **Ease Of Construction**

Consideration should be given to access and operating space for plant and equipment.

- f) **Land Acquisition**

On pipeline routes, remote groundbeds are inevitably off the right of way, requiring additional land purchase, where possible sites should be chosen to avoid difficulties in land acquisition. In plant areas, groundbeds should preferably be sited within existing boundaries.

- g) **Groundbed Type**

There are several types of basic groundbed design.

 - i) **Standard Horizontal**

This is the simplest type of groundbed consisting of inert anodes laid horizontally at intervals in a trench filled with

carbonaceous backfill. This design is suitable when surface ground conditions are reasonably dry (i.e. a trench up to 2 metres deep can be opened and kept clear of water) and surface soil resistivities are low.

ii) Vertical Anode

This type of groundbed consists of inert anodes installed vertically at intervals in small boreholes and surrounded with carbonaceous backfill.

This design is utilized when surface resistivities are high with a lower resistivity directly below (5- 10 m depth).

iii) Borehole

Deep borehole groundbeds are used when surface resistivities are high with low resistivity existing only at length. Anodes are installed in the low resistivity zone surrounded by carbonaceous backfill. Typically boreholes are 50- 100 m deep.

Borehole groundbeds are also used where surface space is at a premium such as in plant areas. Remoteness being achieved vertically rather than horizontally.

iv) Canistered Anode Groundbeds

As stated above, anodes are normally surrounded with a carbonaceous backfill material. In very wet-swampy conditions, installing carbonaceous backfill can be difficult and there is always a risk of wash out before consolidation can occur. The use of anodes prepackaged with a backfill in a sheet steel canister overcomes this problem. Installation is very easy and the steel canister will corrode away leaving anode in backfill after consolidation has occurred. Canistered anodes can be installed either horizontally or vertically.

v) Anode Type

Silicon Iron, graphite and magnetite materials are all commonly used in buried onshore groundbeds and generally exhibit similar properties when surrounded with carbonaceous backfill.

The recently developed mixed metal oxide tubular anodes also perform well in carbonaceous backfill and are particularly applicable for borehole groundbeds as installation is much easier than with other types of anode.

vi) Carbonaceous Backfill

In the vast majority of onshore groundbeds, a carbonaceous backfill material is used to surround the inert impressed current anodes.

The backfill increases the effective size of the anode obtaining a lower resistance to earth, and by forming the anode/soil interface carries the majority of the consumption resulting from current discharge.

h) Groundbed Design

Deciding groundbed size, plus the number, size and spacing of anodes in a groundbed depends on several factors primarily:

- i. Required groundbed resistance to earth
- ii. Required current capacity
- iii. Maximum anode current density
- iv. Anode weight (based on consumption)

The groundbed design therefore needs to meet the worst case of any of these, which often means other factors are exceeded by significant amounts. The recommended method having chosen the basic groundbed type is to size the groundbed according to the desired maximum resistance and then to cross

check that sufficient anode material is available to provide the required current and allowing for anode consumption.

Groundbed Resistance

The groundbed resistance to earth is primarily determined by the soil resistivity in which it is installed. It is normally the largest factor in the overall circuit resistance which also includes cable resistance, the resistance across the structure coating and the resistance required to overcome the Back EME the groundbed and structure (of the order of 2 volts for most anode materials).

The cable and coating resistance components can be calculated accurately but a rule of thumb is to allow 0.5 ohms for all the additional factors.

The groundbed resistance to earth is calculated using an appropriate formula for the geometry of the proposed installation.

Anode Current Density

As a general guide, the required anode surface area approximately 50% of the quoted maximum current density.

Once sized, the minimum number of anodes can then be determined by dividing in the total current requirement by the current obtainable from one anode.

If the anode material maximum current density is quoted at A/m² using an anode with a surface area of 0.5 m², at 15 Nm² the current output would be 7.5 Amps. Therefore if a total of 30 Amps was required a minimum of 4 Anodes would be needed.

Anode Weight

The minimum total anode weight required can be calculated from:

$$\text{Wt (kg)} = \frac{\text{current (Amps)} \times \text{Life (Yrs)} \times \text{Consumption (Kg/Amp -Yr)}}{\text{Utilization Factor}}$$

Example:

Current = 30 Amps

Required Life = 20 Years

Consumption = 0.1 Kg/Amp-Yr

Utilization Factor = 0.5(50 %)

$$\text{Wt(kg)} = \frac{30 \times 20 \times 0.1}{0.5} = 120 \text{kg}$$

Therefore, if 20 kg anodes are used a minimum of 6 nos. are required.

Spread

When installed and commissioned if we plot the pipe to soil potential before and after the application of cathodic protection to a pipeline from a single power impressed cathodic protection station, typical results are demonstrated below:

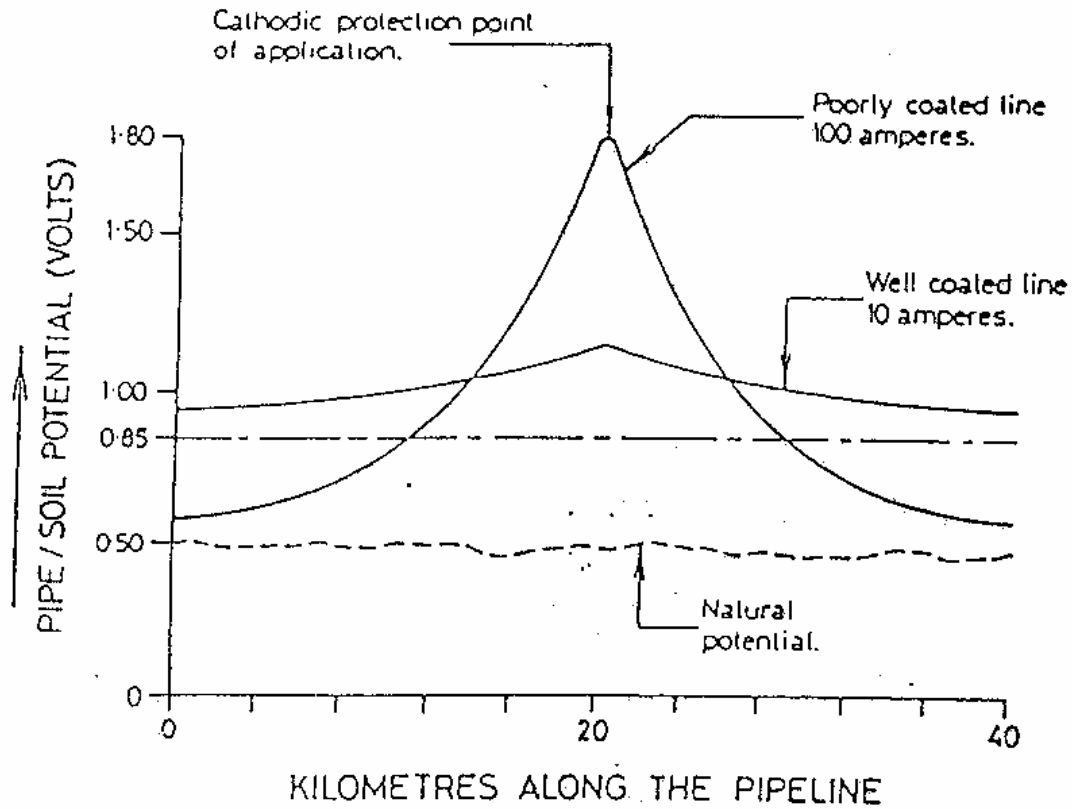

Figure 7 Pipe to soil potential before and after the application of cathodic

The well coated line is protected over the full 40 kilometres using a current of 10 amperes (at say 10 volts) and with a peak potential of -1.05 volts. Practically this could represent a current density requirement in the order of 25 micro amperes per square metre of coated pipe. The poorly coated, or bare me, requires the drain point potential to be elevated to -1.8 volts for a protective spread of less than 16 kilometres; a current of 100 amps is utilised with current density in the order of 1 to 3 milliamps per square metre of pipe.

The extent to which current will spread from a single installation is a function of:

- limits to which the drainage point potential can be depressed
- soil resistivity
- coating quality
- pipeline continuity resistance

It is also affected by intrusive factors such as the connection to the line of a bare metal area, 'interaction' from DC to AC services or localised loss of coating or continuity.

The ultimate cathodic reaction is the production of alkali and hydrogen. Alkaline materials are protective to steel but hydrogen is thought to cause inter-crystalline embrittlement and fracture. Hydrogen does not normally evolve before the pipe/soil potential is more negative than -2.5 volts but this is almost entirely dependant on the surface condition of the steel and soil conditions. In any case, the evolution of volumes of hydrogen or the production of alkali is disruptive to any coating material and for this reason the limiting pipe/soil potential at the 'drain' point is generally taken to be -2.5 volts.

Soil resistivity as a rough measure of soil aggressivity also dictates the level of current density necessary to provide protective potential. This is likely to be very much greater in low resistivity soils/aerated salt marshes or anaerobic clays than in high resistivity areas. The greater the current demand, the greater is the current flow in the pipeline itself. Measured current flow in the pipeline results in increased 'volt drop' along the pipeline so that it becomes necessary to produce a high drain point potential in order to achieve the required minimum at the distant point. This current spread is dependent on current demand which is function of coating quality and pipeline linear resistance.

These factors are susceptible to a mathematical evaluation and by combining this theoretical approach with practical parameters, it becomes possible to specify coating quality by stipulating the current density necessary to achieve a given distant change in potential with a specified maximum change in potential at the drainage point.

5.6 Special Considerations for Onshore Cathodic Protection

a) Sparking Hazards

Where impressed current cathodic protection systems are used in plant areas for the control of corrosion of buried pipelines and buried metallic storage vessels both the buried and the above ground pipe work becomes part of the cathodic protection electrical circuit. When it becomes necessary to break the electrical continuity of these circuits (e.g., through the separation of pipe work from vessels or the removal of pipe work spool pieces, valves, or cold cutting of pipe work) there is a risk that if a flammable gas or vapour environment exists, incentive sparking may occur as the circuit is broken or when the circuit is purposely or accidentally remade and a fire explosion could result. Generally, the system of inter-bonding between cathodically protected product pipelines, fire mains and copper earthing creates parallel paths for cathodic protection current. These paths may act to prevent sparking when p is broken but cannot safely be relied upon as they cannot be readily identified. It must therefore be considered necessary to have a system whereby electrical continuity is not disturbed during the removal of pipe sections or equipment in hazardous areas or on product carrying pipelines and this may be achieved by the use of safety bonds.

b) Earth Electrodes

Where cathodic protection is applied to plant area buried structures and their associated earth electrodes, it is possible that the protection system may cause a reduction in the efficiency of these earth electrodes.

This possible increase in earth resistance, results from a high resistance coating being formed on the copper electrode. Periodic

maintenance should be undertaken to check, in particular, the resistance of earth electrodes located close to impressed current groundbeds.

c) Sleeved Crossings

The environment inside a sleeve is very different to the environment of a conventionally buried pipeline. If designed to be air the possibility always exists that soil water will fill the annulus. The danger is that a differential condition is established and supplementary cathodic protection in the form of galvanic anode ribbon should be allowed for within the annulus.

Other approaches have been to design to produce a specific condition susceptible to corrosion prevention. Small diameter lines can be sleeved in pipe of larger diameter with inert gas in the space in which case the external sleeve surface is treated as the rest of the pipeline. Alternatively, and in the case of larger lines, both the carrier pipe and sleeve should be well coated and insulated from each other and provision made for the annular surface to be well drained or filled with a gel of conducting material so that the carrier pipe may be cathodically protected.

d) Valve Pits

As with sleeved crossings, conditions inside a valve pit will differ from the rest of the pipeline. Pits designed to be drained do nevertheless fill with water, or at best provide a very high humidity climate in which corrosion is rapid in the vapour phase. In these cases, corrosion prevention should be based on the use of coatings and local cathodic protection by galvanic anodes which would automatically energize when the water level reached pipe invert.

e) Cathodic Protection Interaction

Whenever there is current flow in the earth, from whatever source, a piece of metal buried in the earth may function as a part of the current path, collecting current over a part of its surface and discharging it with attendant corrosion from another pad.

This may be illustrated by a 'secondary' structure or pipeline passing within the influence of a cathodic protection system installed on the primary structure. Here current from the groundbed may utilise the secondary structure to return to the cathodic protection power source, most likely discharging from the secondary structure at its crossing point with the primary protected structure.

This condition is recognised by pipe to soil potential changes at point on the secondary structure when the protection system the crossing is energized. Changes in potential which tend to produce an anodic condition must be dealt with and this can be done by the two pipe lines together. This effect is illustrated by the figure 8.

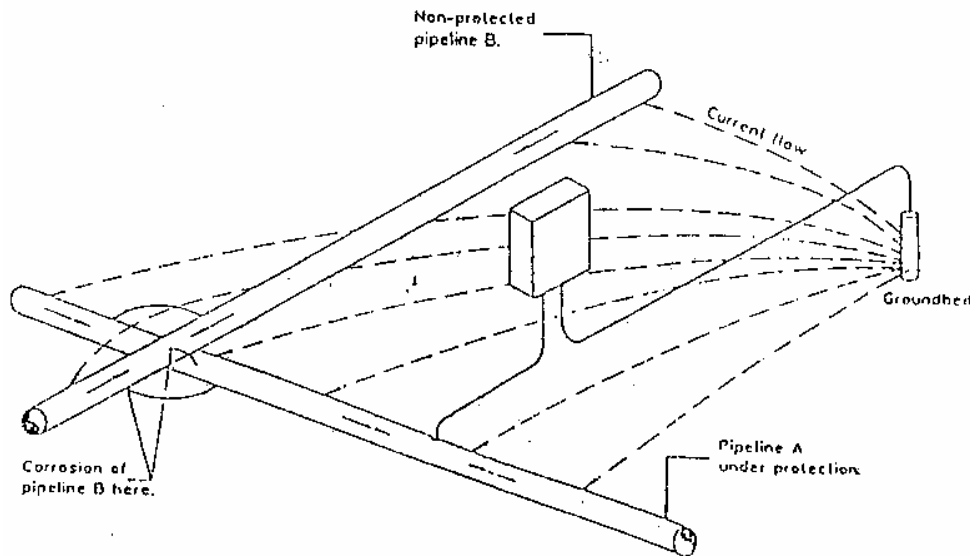

Fig.8 Interaction at pipe crossing

f) AC Induced Effects

Pipelines buried parallel to high voltage overhead transmission lines are subject to induced alternating voltages from the currents flowing in the powerline cables. The pipeline voltages are produced by the electric field transformer coupling between the three-phase current-carrying overhead conductors and the buried metal pipe which is normally isolated from the surrounding earth by the electrically insulating anti-corrosion coating. Under balanced (equal) current flow in each phase of the powerlines, the induced voltage in the pipeline is normally less than 10 volts as the sum of the field effects of the load currents is small and results only from different distances between the pipeline and each conductor.

However, the induced pipeline voltage will increase markedly during AC transmission line faults which may be caused in a variety of ways. Typically, faults may be caused by the earthing of any of the conductors, unbalanced loading of three phases or by lightning strikes. Any of these faults may cause large 3 currents to flow in the conductors, which will produce strong alternating electric fields to couple with buried pipeline and induced high voltages over the parallelism.

The magnitude of the induced voltage will depend on several transmission line and pipeline factors. For example, the distance separating the power line and pipeline, the distance over which they are parallel, the existence of other parallel pipelines, the pipeline coating quality, pipeline earths, the effect of the powerline earth conductor and the trip time of the powerline protection devices. The voltage gradient produced over the pipeline rises at the ends of the parallelism as would be expected of an open circuit conductor in alternating electric field. The value to which the voltage rises will be affected in several ways. The AC powerline earth conductor will cause the electric field to be reduced because the currents induced in the earth conductor will

flow in opposition to the fault current and produce an electric field which is also in opposition to the field of the fault current. The resulting total field strength affecting the pipeline is therefore weakened. Multiple pipeline routes will be less affected by induced voltages than single pipeline parallelisms. The paralleling pipes will share the induced, energy with resulting lower voltages per pipeline and, by virtue of the larger surface area, increased leakage. A similar reduction in level will occur from fault currents flowing through the earth from the pylon footings when the conductor is in fault contact with the powerline. Operators working on valves or cathodic protection equipment or passers-by touching exposed cathodic protection cables are most vulnerable to these voltages and efforts need to be made to reduce the voltages to levels such that safety is assured and equipment is not damaged. The most effective method of reducing the voltage is to change the condition of the pipeline from an open ended, insulated conductor to one forming part of a current carrying close circuit.

This condition is most easily produced by connecting the pipeline to the surrounding soil, enabling current to flow through the soil along the voltage gradients occurring along the pipeline from the induced voltage effect. In one case, zinc earth electrodes were installed at the ends of each parallelism with additional electrodes placed at 4 km intervals along the route. The electrodes 'connect' the pipe to the soil and by allowing a flow of current, the voltage rise is limited. The resistance to earth of the electrodes is kept below 7 ohm so that the volt drop at the electrode due to current flow and the resistance does not rise to dangerous levels.

In addition, where operators were required to work on pipeline equipment such as line valves, earth mats of zinc ribbon were laid round the valve and connected to the pipeline. An operator standing by a valve and in contact with it, would not therefore be at risk should a high voltage be induced on the pipeline since the earth mat potential and the surrounding soil on which the

operator stands would change voltage with the pipeline, preventing the operator becoming an earth path. The potential between the equipment being touched and the operators foot or the space between this feet when walking is referred to as the is 'step voltage and to be safe, should not exceed 200 volts for a fault duration of 200 microseconds.

All surface fittings and other test facilities on the pipeline along the parallelism are out of the public's reach and cathodic protection test terminals, normally exposed at test posts, are enclosed in posts made of high impact non-conducting materials.

A further effect of induced AC voltages is that by being conducted to earth through a cathodic protection station, AC is converted to dc and in effect becomes an impressed current power source. This effect may not be totally beneficial as pipe to soil potentials from this source may easily exceed the designed limits.

The flow of AC through the cathodic protection station may, however be limited by the use of inductive and capacitive circuits which will by pass the current around the transformer - rectifier. The typical circuit is shown in the following Figure 9.

6.0 Cathodic Protection Equipments and Maintenance

6.1 General

Although materials and equipment has been discussed in various parts of the course a brief survey of the most important materials is provided and typical manufacturers data sheets.

6.2 Transformer-rectifiers

A transformer-rectifier steps down the mains AC supply voltage (230V single or 415V 3-phase) to a low AC voltage (25/50 volts) and then rectifies via a full wave bridge connected circuit, the low voltage to direct current. The transformer is provided with switched transformer taps which vary the AC transformer output, an ammeter and voltmeter and protective circuits and fuses. As the unit operates continuously, large units are oil cooled. Small units may be air cooled in temperate areas. Alternative DC supply sources are solar generators, thermo electric generators, closed cycle vapour turbines, diesel and gas generators.

6.3 Sacrificial Anodes

These are castings of various weights of magnesium, zinc or aluminum alloys round a steel core. For land use magnesium is used and a cable is attached to the core. Zinc and aluminum are generally used for marine service when the cores are welded to the structure being protected.

6.4 Impressed Current Anodes

These are castings of silicon iron of various weights into which cables are connected by lead run joints. Alternative anode materials are graphite, magnetite and, in marine use, platinised titanium and niobium.

6.5 Backfill

To reduce the resistance to earth of buried anodes, they are often buried in trenches or pits filled with coke, calcined refinery coke or graphite. Burial in coke increases the life of the anodes.

6.6 Insulated Flange and Isolating Joints

Electrical isolation may be achieved by the use of either insulated flanges or monolithic isolating joints. Isolating joints are considered to possess a far higher degree of electrical and mechanical reliability than insulated flanges, as isolating joints may be factory assembled and tested to the client's requirements, whereas insulating flanges rely on the site installation of insulating materials into standard flanged assemblies.

7.0 Specialised Pipeline Survey

7.1 General

A number of specialised pipeline surveys which provide detailed monitoring of the pipeline cathodic protection and/or external coating system are available. In addition to the traditional Pearson-type coating survey, two further surveys may now be considered the close-interval potential survey (CIPS) and the signal attenuation coating survey (SACS). Each survey has its particular applications and indeed, the surveys may be used in conjunction with each other.

7.2 Close-Interval Potential Survey (CIPS)

The usual cathodic protection operating procedure is to monitor the performance of the system and by inference, the performance of the external coating system, on a pipe to soil potential measurement sampling basis. Under normal circumstances these measurements provide an acceptable indication as to the overall protection level on the pipeline.

The measurement of potentials at say 1 km intervals is, however, only valid where coating quality is predictable, thus ensuring consistent cathodic protection levels. If this is not the case, then it cannot be

assumed that potentials are maintained between test posts and an intermediate defect may remain undetected.

Where variable coating or environmental variations are suspected, pipe to soil potential surveys may be completed at close intervals along the pipeline, in order to locate any inadequacies in the corrosion protection system. Such a close-interval potential survey may be undertaken at any selected measurement interval, relating to the variations in coating quality, the diameter and the depths of the pipeline. Typical values are between 1 and 5 meters.

The survey method may also incorporate the measurement of instantaneous 'OFF' potentials where synchronised interrupter units are installed at the cathodic protection stations to interrupt the dc supply for short cyclic periods. Commonly this cycle time is 1 second 'OFF' and between 2 and 4 seconds 'ON', depending on the polarisation characteristics of the pipeline. Time synchronisation of the interrupters is confirmed at the beginning and end of each working day.

The value of recording an instantaneous 'OFF' potential is that it provides a record of a polarised potential which is 'IR drop' free. In addition the comparison of 'OFF' and 'ON' potentials will provide valuable information on the pipeline coating quality and the remedial works subsequently required.

To deal with the large volume of information gathered during a close-interval potential survey, purpose built voltmeter/programmable data loggers and Computer software is required.

7.3 Signal Attenuation Coating Survey (SACS)

When it is required to provide an overall evaluation of a pipeline coating system without walking the entire pipeline route, a signal attenuation coating survey will provide an economic and effective method.

Such a survey utilises a 1000 or 8000 Hz alternating current signal connected between the buried pipeline and a remote earth. The alternating current electromagnetic field may be measured above ground and this enables the level of current flow in the pipeline to be ascertained.

The alternating current flowing in the pipeline is thus recorded by this means using a calibrated, tuned pick-up coil and signal conditioning system. The voltage induced in the coil is proportional to the current in the pipe but is varied by pipe depth. The pipe depth is accurately measured at each signal measurement point and the receiver signal calibrated to allow for signal loss related to the depth measured.

Utilising such an instrument, current readings may be recorded at discrete points on the pipeline and the data rapidly analysed to reveal the signal current loss over any section of pipe. It is possible therefore to use this technique to monitor, normally inaccessible sections, i.e. river, rail and road crossings, by recording a current reading each side of the crossing.

A typical procedure for a signal attenuation coating survey would be to record current at intervals which produce signal losses of about 4 dB. If a pipeline section is seen to be losing significantly more than the expected loss, the fault location may be found, firstly, by taking readings at subsequent half-way points and finally by walking the pipeline and constantly monitoring the current level.

7.4 Pearson -Type Coating Survey

The information gained from this survey, is subjective and is particularly reliant on the experience of the survey operator.

Where access along the pipeline is freely available the Pearson-type coating survey may still be economically employed; particularly on a newly laid pipeline where coating defects are likely to be isolated. Classification of defects, however, may only be confirmed by selected excavation and inspection.

7.5 Direct Current Voltage Gradient (DCVG) survey

When dc current is applied to a pipeline in the same manner as in cathodic protection, ground voltage gradients are established due to the passage of current through the resistive soil. A well coated pipeline has a high resistance to the soil. However, at defects the resistance is lowered such that current flows through the soil. The flow of this current will create a voltage gradient which becomes steeper as it approaches to a defect. The larger the defect size the greater the current flow and hence voltage gradient.

An asymmetrical dc signal impressed onto the pipeline is switched ON and OFF in the ration of 3:1 per second. A sensitive millivoltmeter is used to measure the out of balance signal between two half cells placed in the voltage gradient at the vicinity of the defect. The direction of deflection will represent the direction of current flow due to the voltage gradient. The defect location can be determined by tracing up and down in parallel or perpendicular direction to the pipeline. As a defect is approached, the operator will see the milivoltmeter start to respond to the impressed dc signal and point in the direction of current flow. When the defect is passed, the deflection will reverse and slowly diminish as it moves away from the defect. By tracing the defect to where the half cells show a null deflection on the meter, it is then located midway between the two half cells.

8.0 Conclusion

The content of this course is intended to provide overview of cathodic protection.

Although some formulae and design parameters are stated document must not be considered as a design guide. It vital in designing any cathodic protection system that qualified, experienced cathodic protection engineer consulted.

9.0 References and Suggested Additional

- i) British Standard Code of Protection.CP7631:1991
- ii) Cathodic Protection by John Morgan
- iii) Control of Pipeline Corrosion by A.W Peabody