

# SAMPLE PAGES

Reproducible

HEIDI SONGS

Grades  
PreK-2



## Counting Creatures

by Heidi Butkus  
Illustrations by Korey Scott

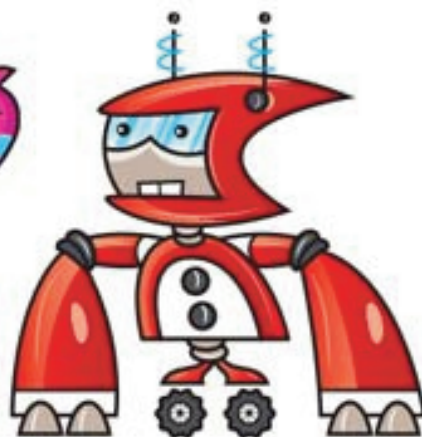

1-10 Number  
Worksheets

# SAMPLE PAGES



PRESENTS

# Counting Creatures

## Number Worksheets

by Heidi Butkus

Illustrations by  
Korey Scott



# Counting Creatures

## Number Worksheet Instructions

This book of worksheets was designed to give children a fun way to practice writing the numerals and numeral recognition. It is my hope that your students will find these whimsical creatures fun and motivational! Please note that we have made an effort to provide a variety of worksheets so that you will be able to pick and choose the most appropriate ones for your class, considering the level that they are at and the time that you have. I would never ask or expect my students to do them ALL, and I certainly hope that most teachers of young children realize that doing them ALL would not reflect "best practices" in the early childhood classroom. Instead, I recommend that you use them selectively as follow-up activities to reinforce what the children have learned through manipulatives in real life, meaningful situations with real objects. In addition, they should make good homework packets for math when given a few at a time.

Here are some suggestions for the different sets of worksheets that are offered in this book.

\* Pages 2-11: Counting Creatures Poem

I copied these pages onto cardstock, colored them, and bound them into a booklet to read to the children. The children enjoy giving the correct number of claps for each Counting Creature! For example, the children clap six times during the counting part when it says, "Robot, robot, number six, How many arms can do those tricks? One, two, three, four, five, six!"

Later, I like to have the children choose their favorite character by graphing their favorite one, and will then duplicate that one for them to color, since we wouldn't have time for them to color all of them.

\* My favorite way of using pages 12-21 and 32-41 is by putting them in page protectors and having the children use them with fine tipped dry erase markers. Even better than page protectors are the thicker, sturdier, dry erase sleeves sold at [www.reallygoodstuff.com](http://www.reallygoodstuff.com) and at other websites.

\* Pages 72-89 are designed to have the children draw the missing parts of the creatures in the correct quantities. Notice that we have also provided full sized creatures for your students to practice drawing on as well! I think that the best way to practice is to use dry erase sleeves or page protectors and have the children draw the teeth, hair, or balls, etc., as many times as necessary until they are comfortable with it.

\* Notice that pages 90-108 are progressive in difficulty. They begin with simply one or two objects on each page, and then add one more item on each page. The last page in the set has no more than ten on each line.

Color the picture.

Name \_\_\_\_\_

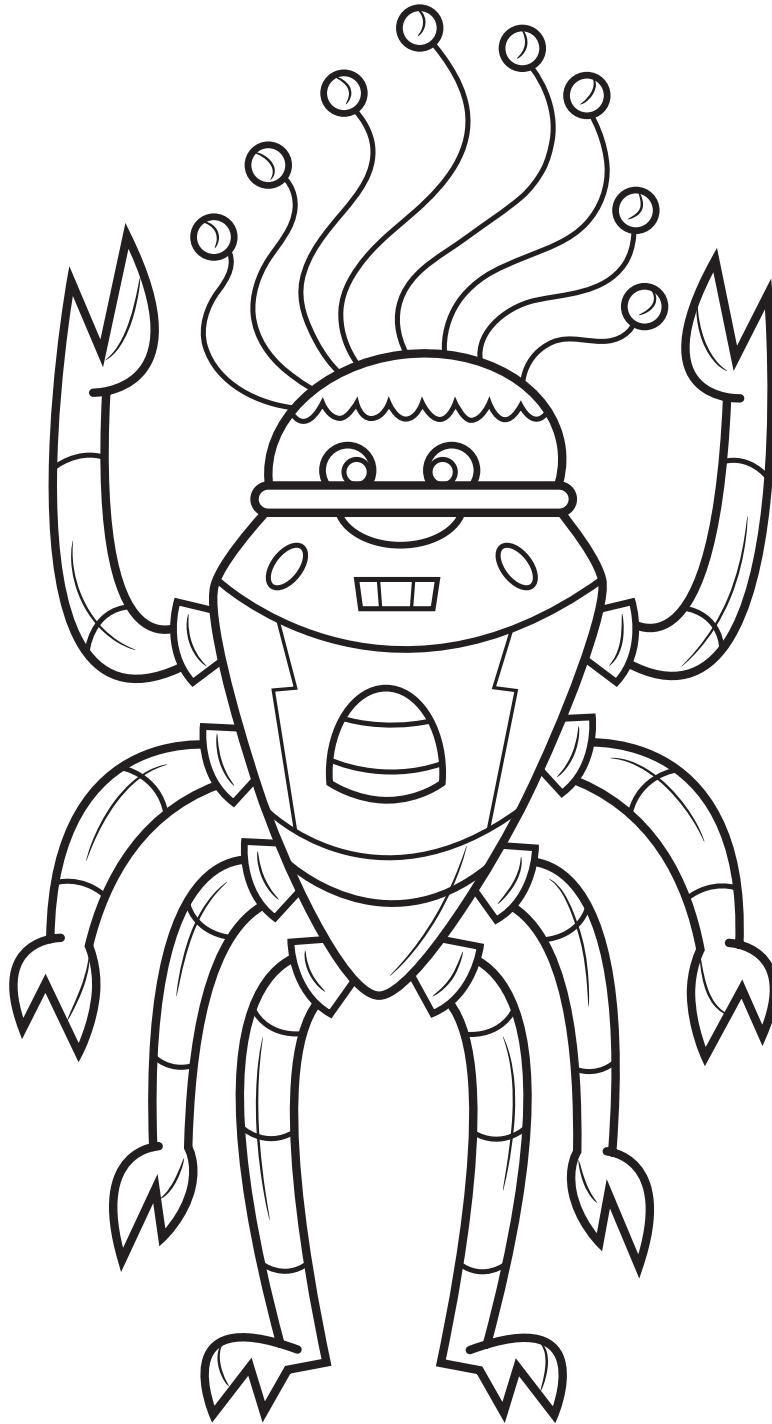

Robot, robot, number eight,  
How many hairs can we locate?  
One, two, three, four, five, six, seven, eight!



Color the picture.

Name \_\_\_\_\_

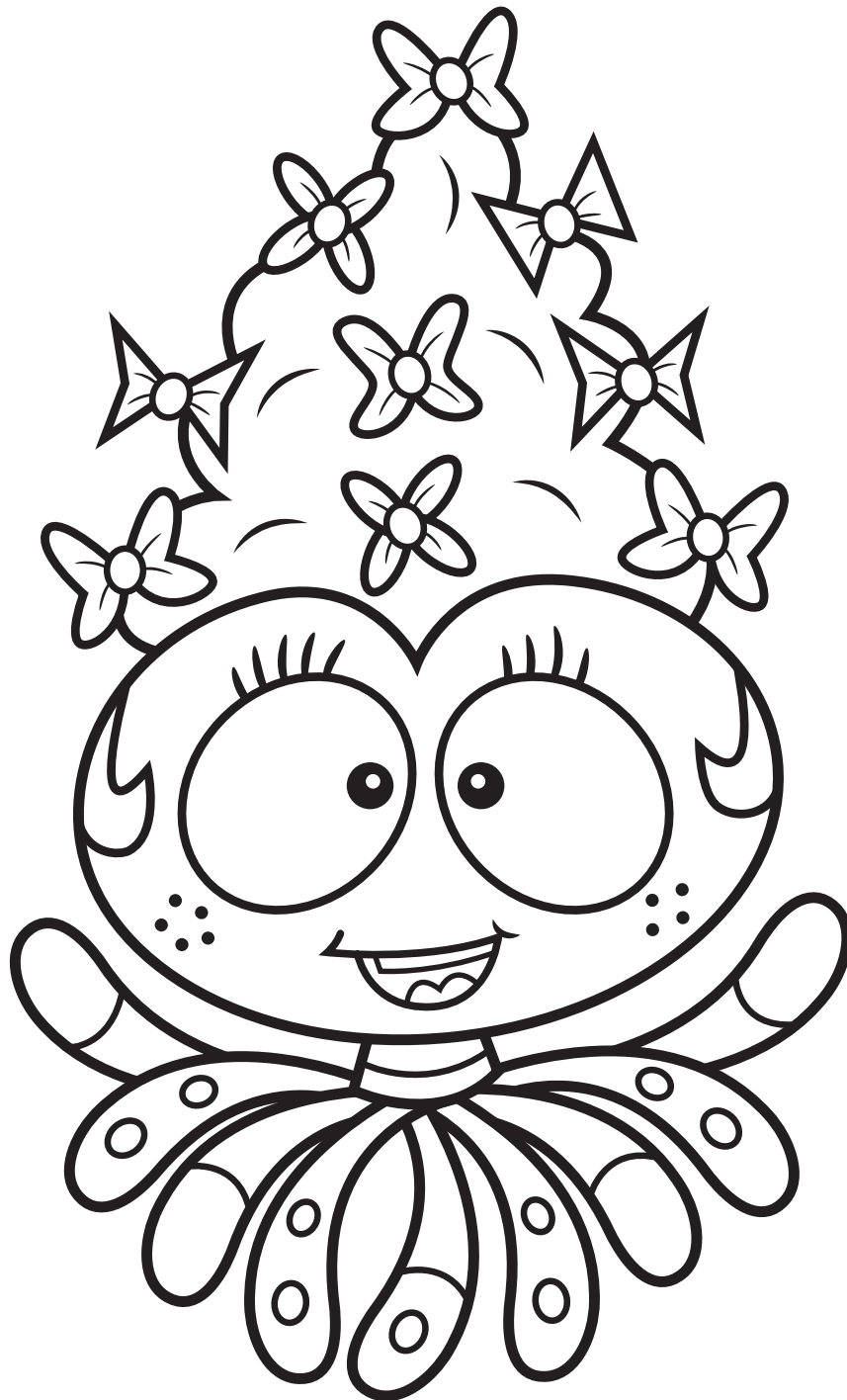

Creature, creature, number nine!  
How many bows make you look fine?  
One, two, three, four, five, six, seven, eight, nine!

Color the picture.

Name \_\_\_\_\_

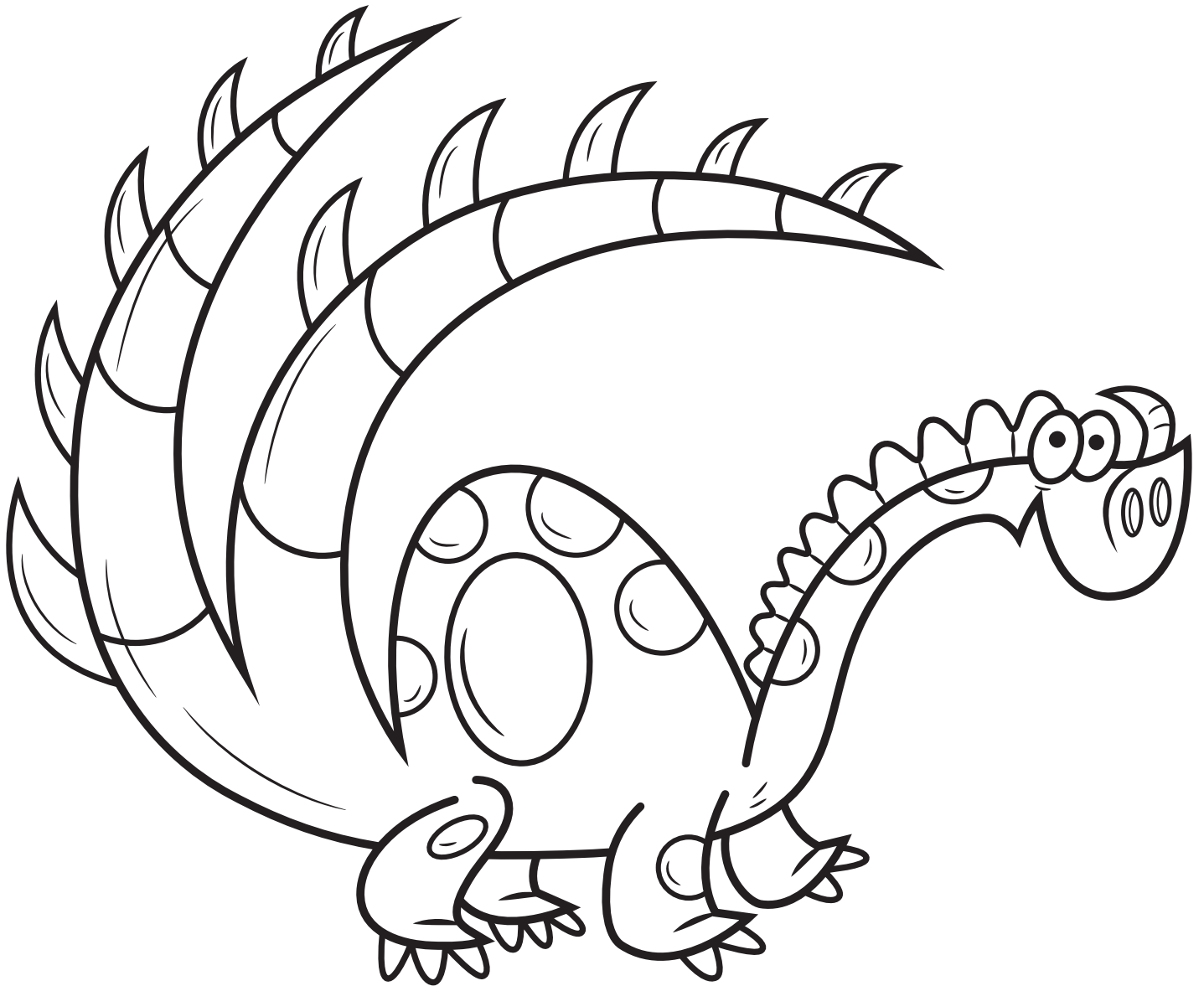

Monster, monster, number ten,  
How many spikes on your rear end?  
One, two, three, four, five,  
six, seven, eight, nine, ten!

Circle all the number 7's  
on this page.

Name \_\_\_\_\_

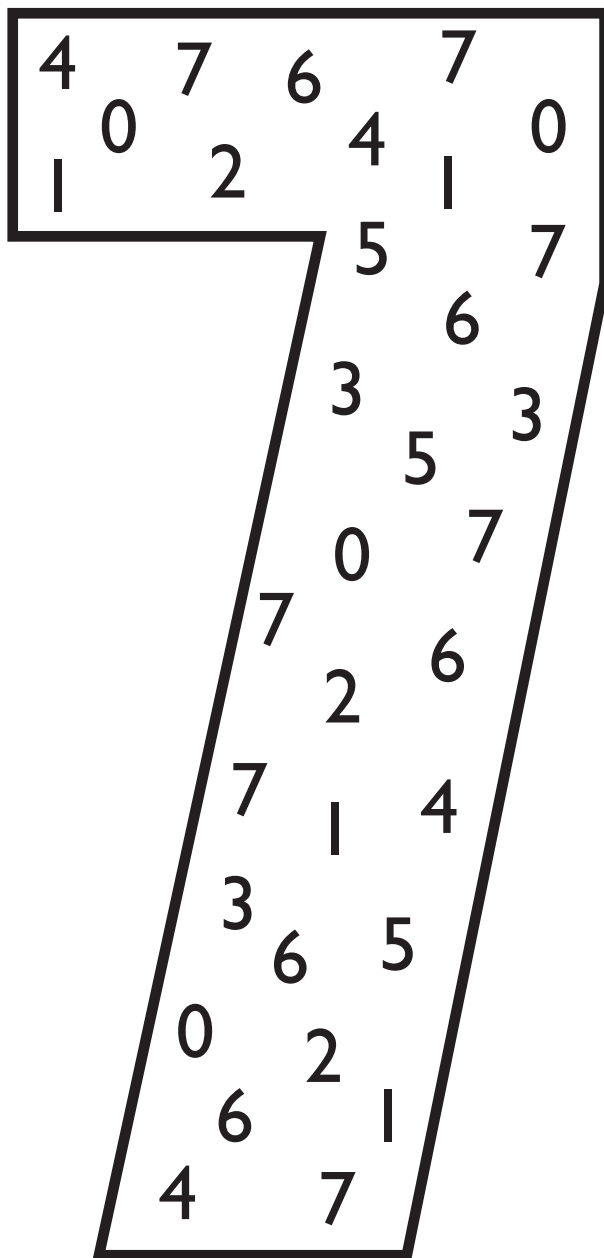

seven

seven seven seven

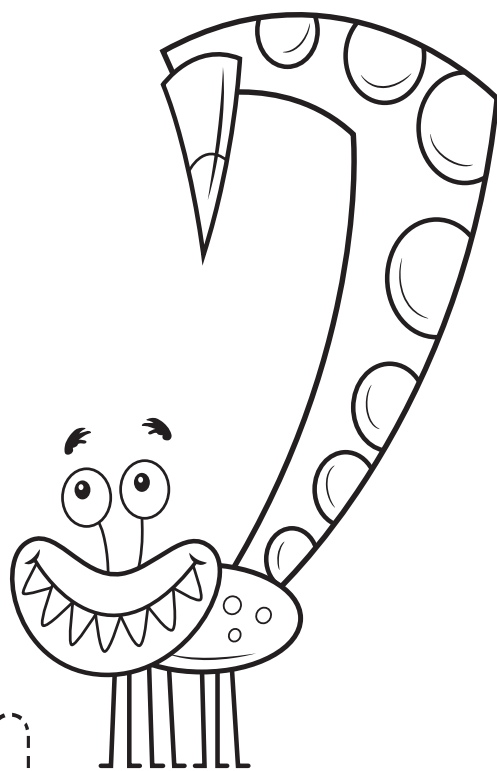

Circle all the number 8's  
on this page.

Name \_\_\_\_\_

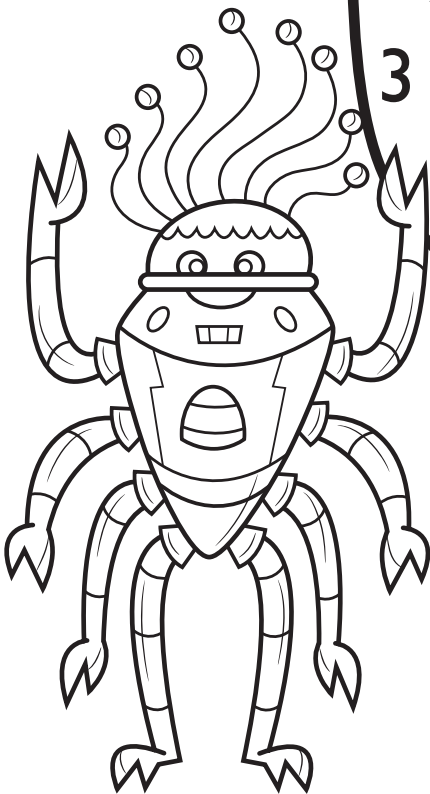
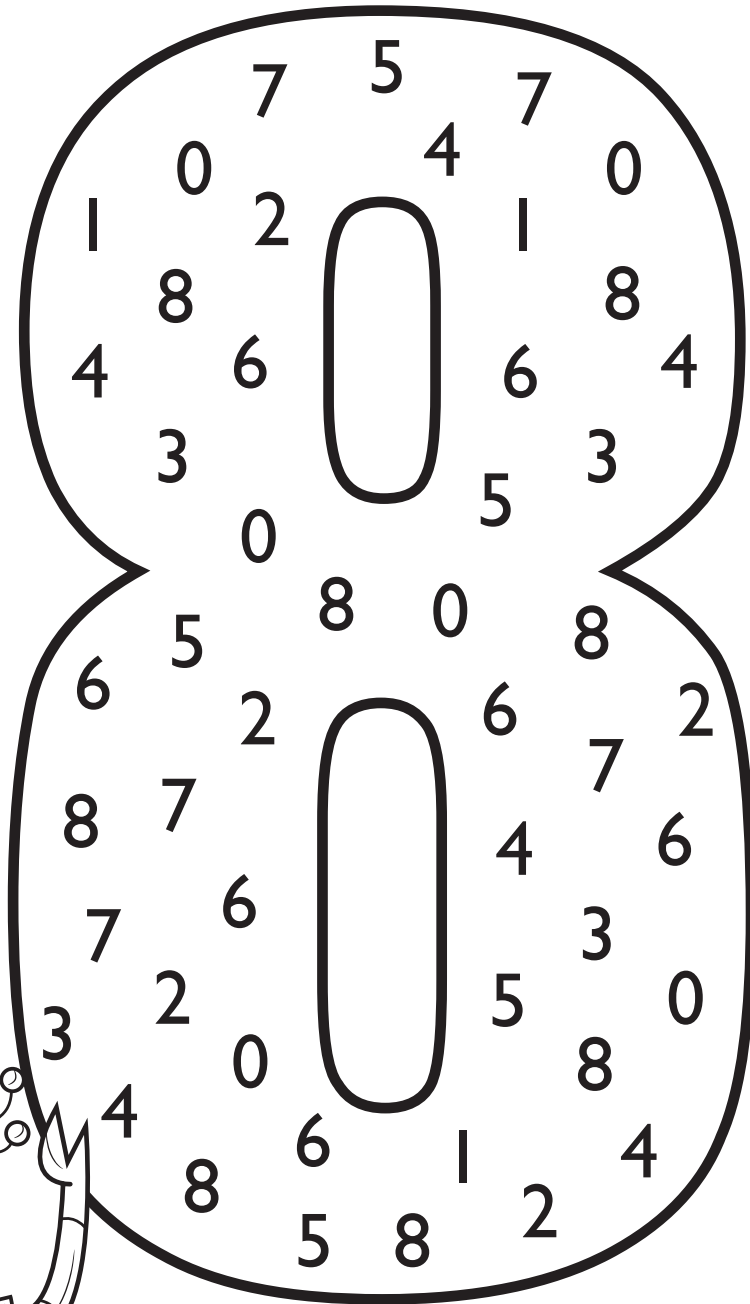

eight

eight eight eight



Circle all the number 9's  
on this page.

Name \_\_\_\_\_

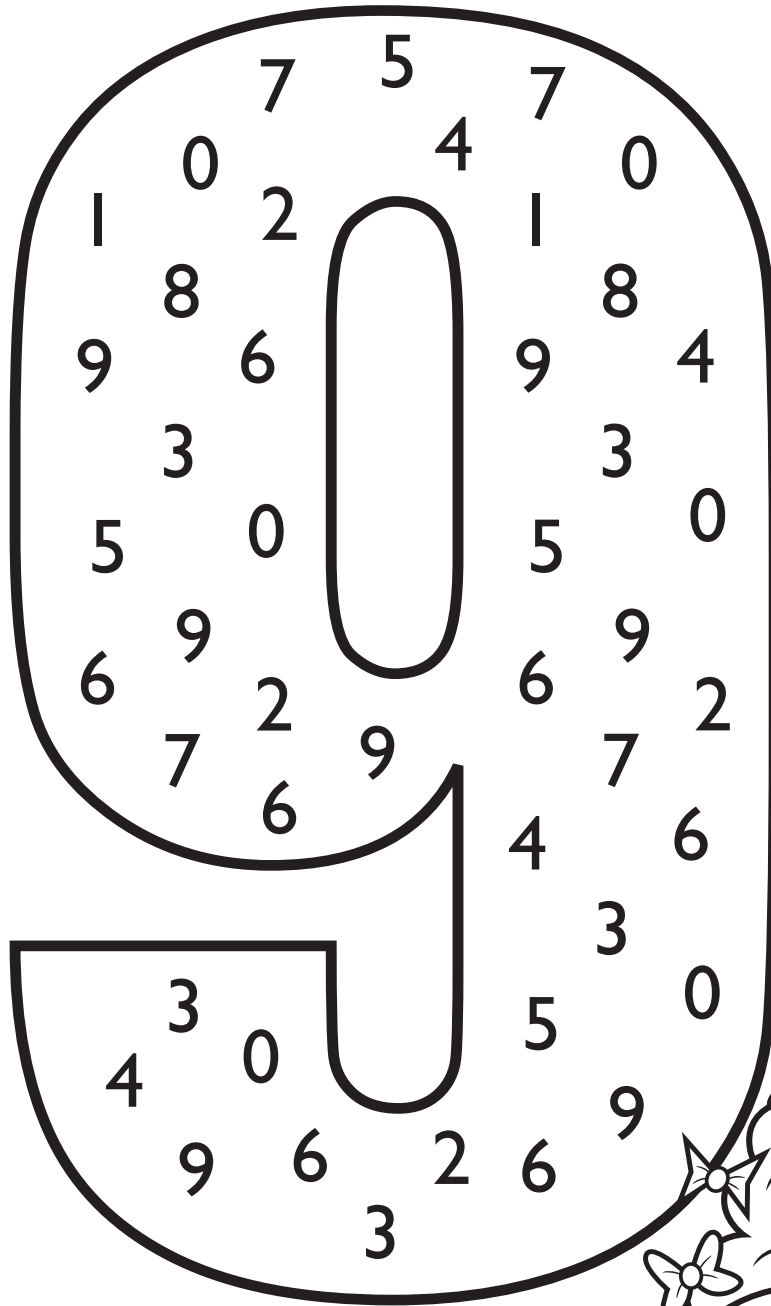

nine

nine nine nine



Color by numbers to find an 8. Name \_\_\_\_\_

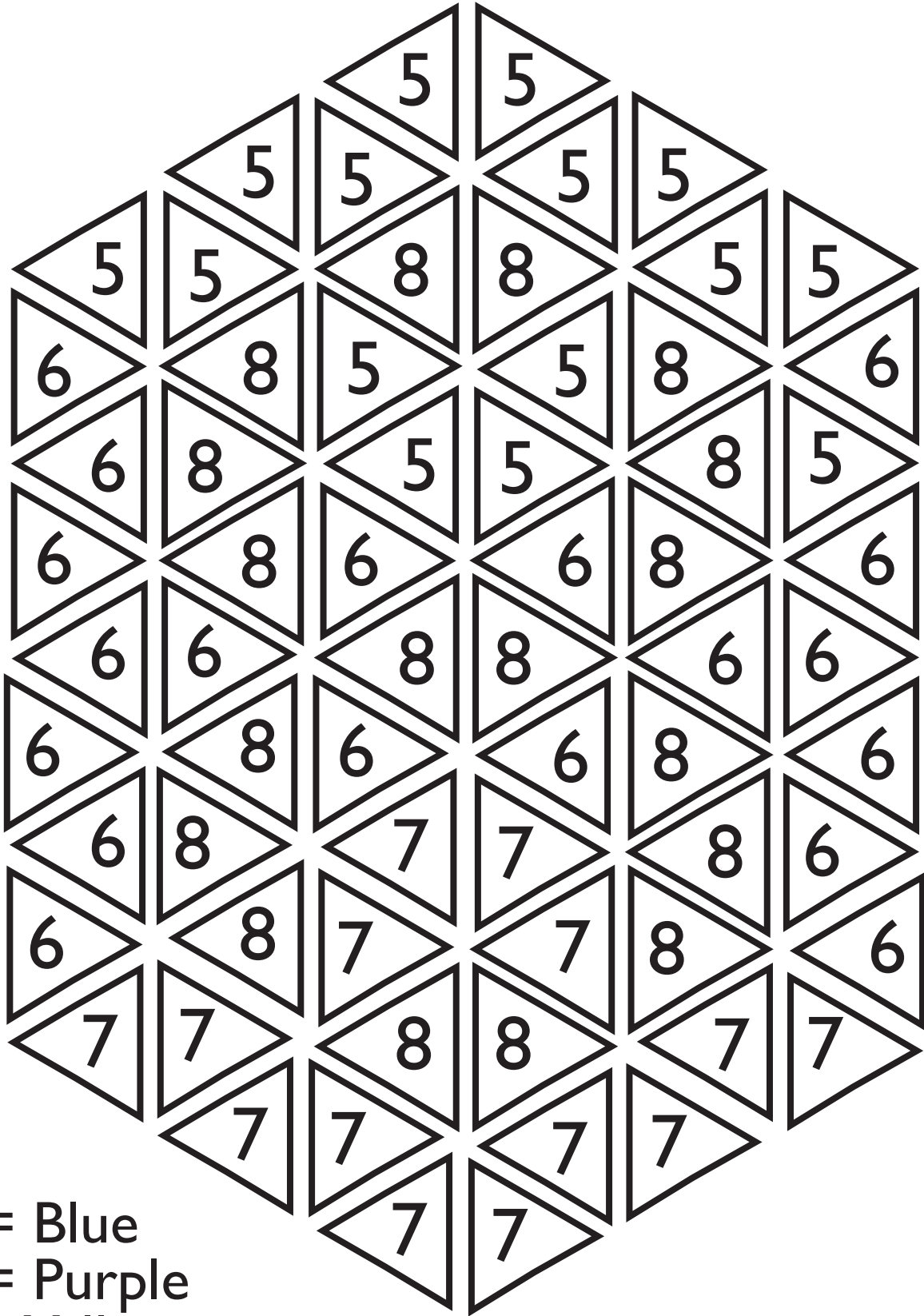

5 = Blue  
6 = Purple  
7 = Yellow  
8 = Red

Color by numbers to find a 9. Name \_\_\_\_\_

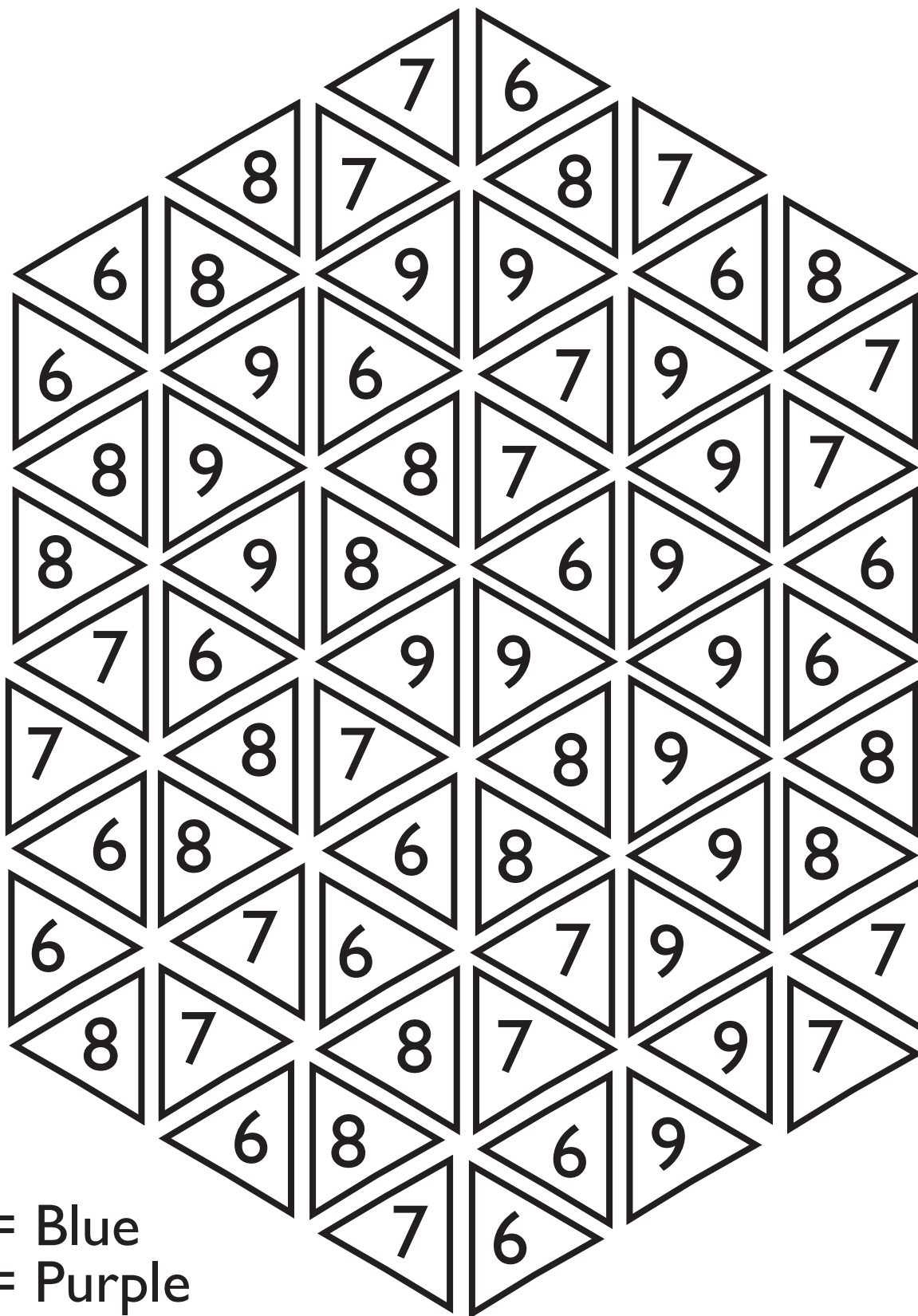

6 = Blue  
7 = Purple  
8 = Yellow  
9 = Red



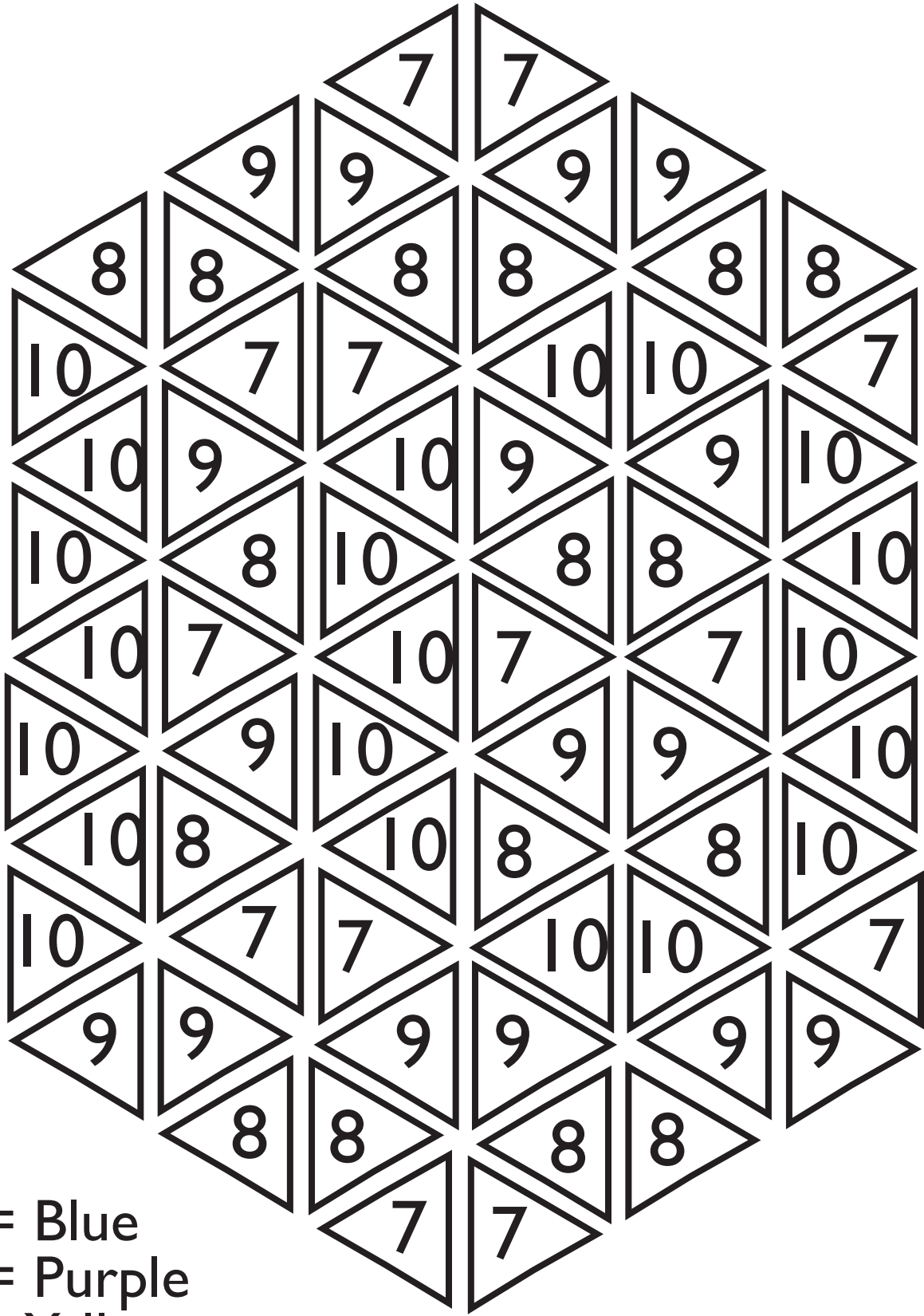







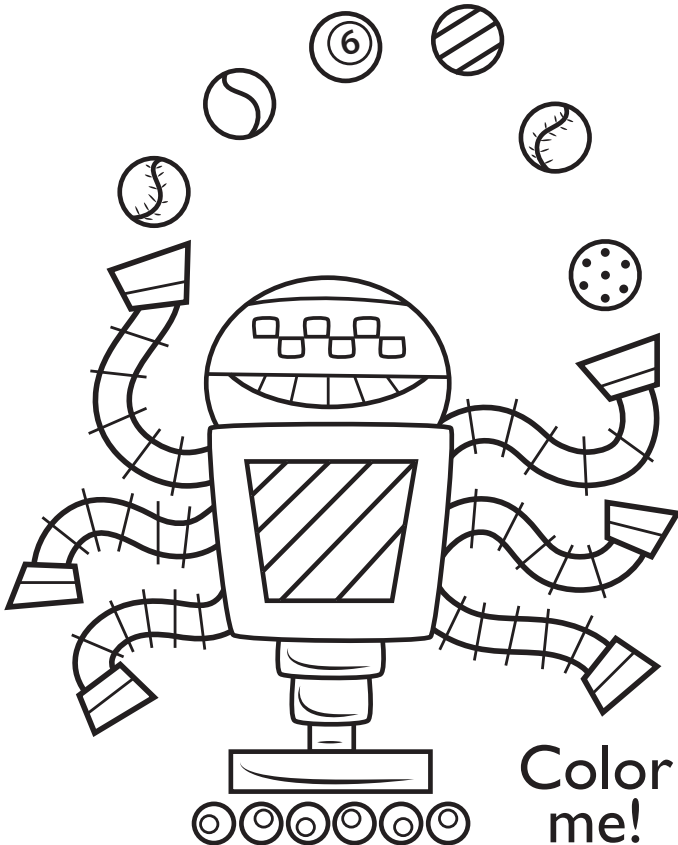





Color by numbers to find a 10. Name \_\_\_\_\_









7 = Blue  
8 = Purple  
9 = Yellow  
10 = Red

Trace and write the number 6.

Name \_\_\_\_\_

 <p>Color me!</p>				
				
				
				

six six six six six

Trace and write the number 9.

Name \_\_\_\_\_

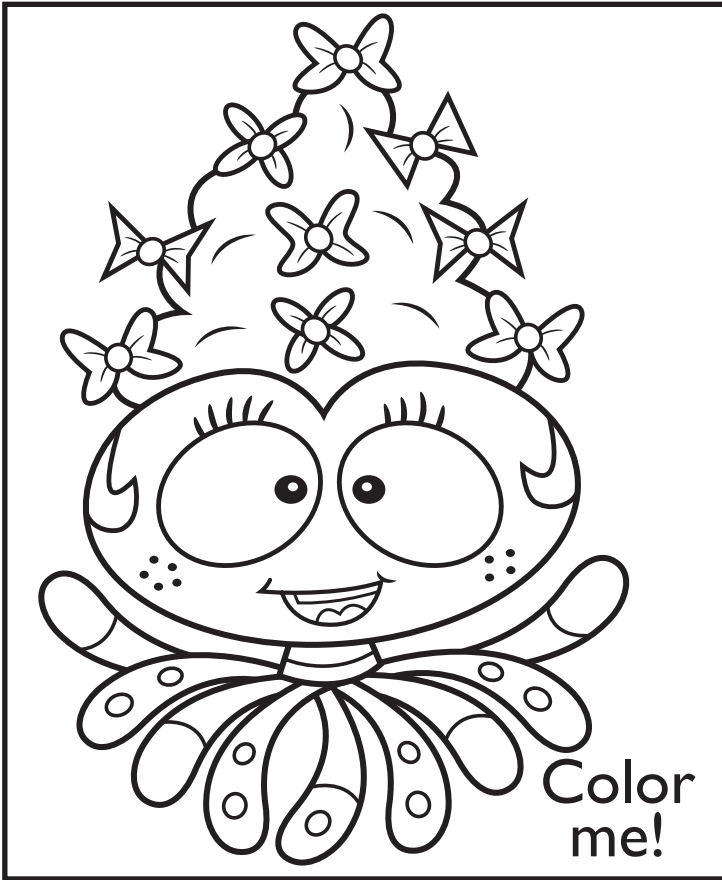

9	9	9	9
9	9	9	9
9	9	9	9
9	9	9	9

9	9	9					
9	9						
9							

nine nine nine nine



Trace and write the number 10. Name \_\_\_\_\_

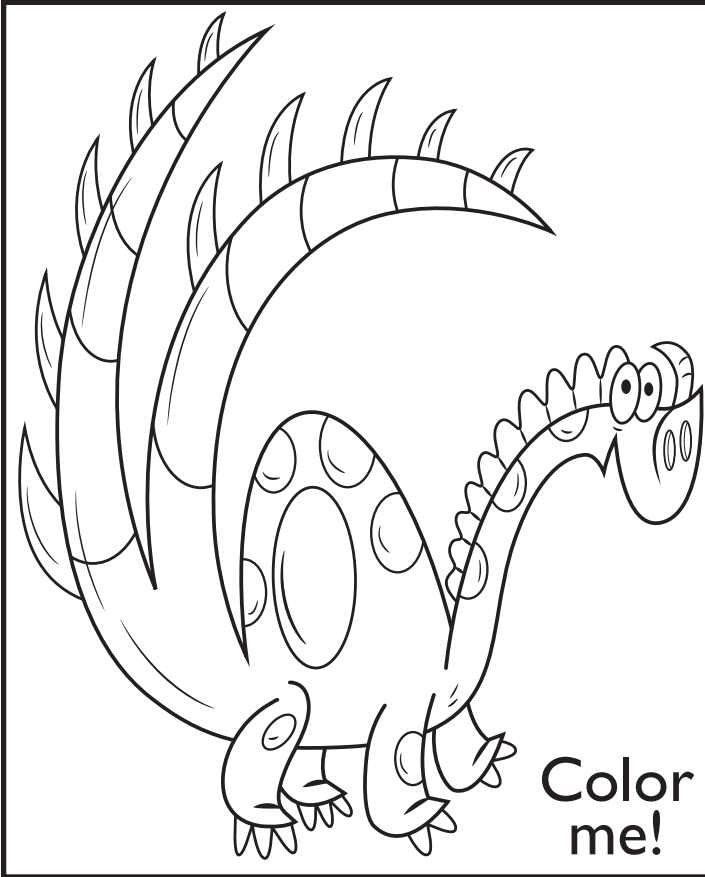

10	10	10	10
10	10	10	10
10	10	10	10
10	10	10	10

10	10	10					
10	10						
10							

ten ten ten ten

Circle the correct number.

Name \_\_\_\_\_

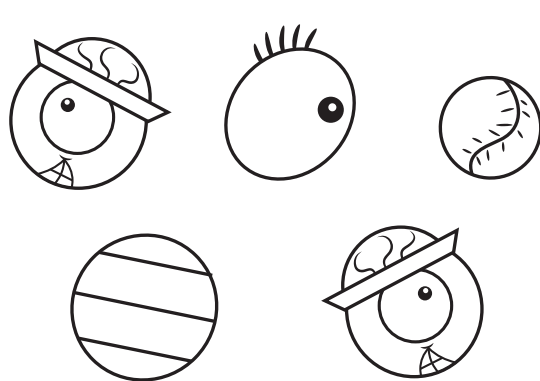

5 6 7 8

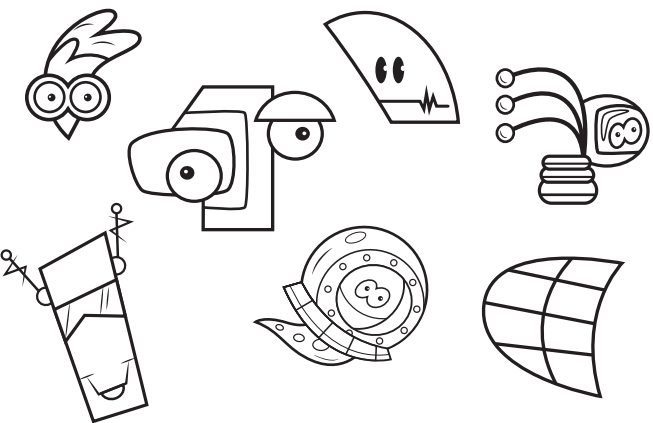

5 6 7 8

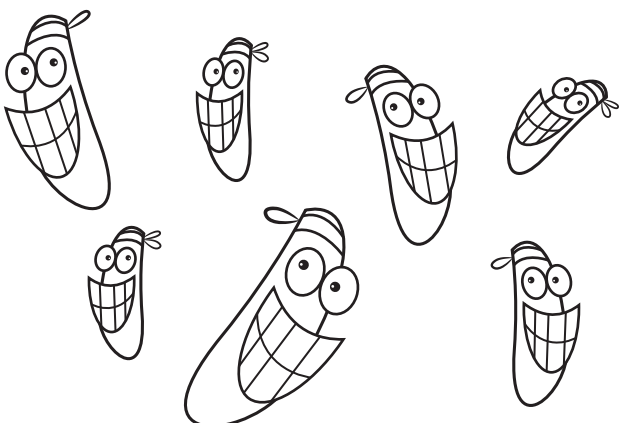

5 6 7 8

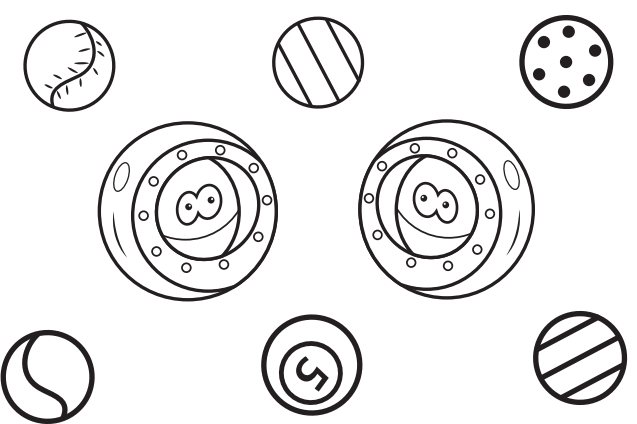

5 6 7 8

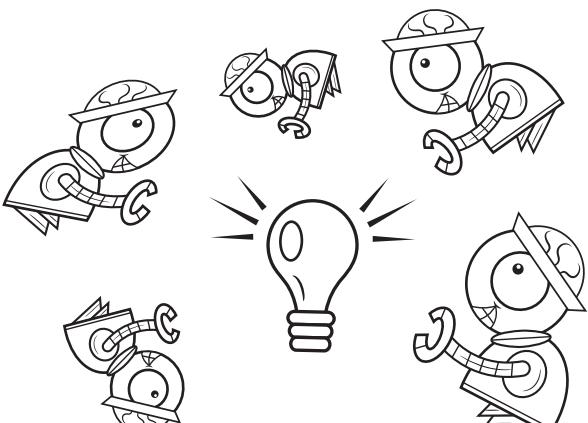

5 6 7 8

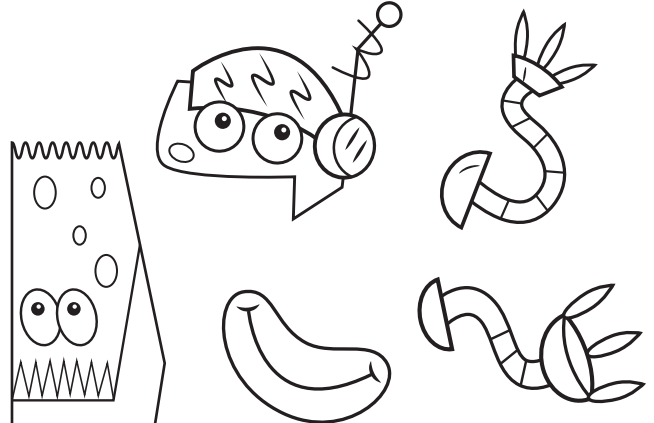

5 6 7 8

Circle the correct number.

Name \_\_\_\_\_

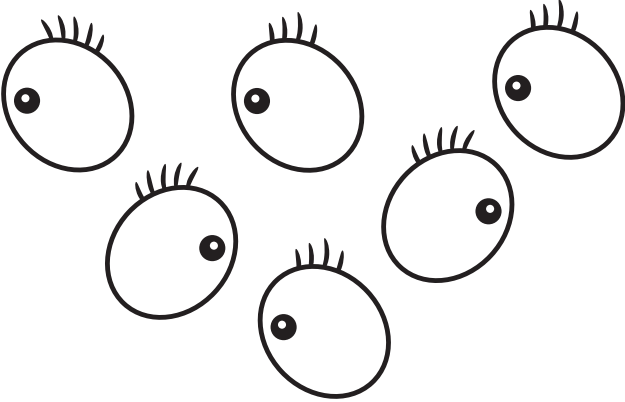

6 7 8 9

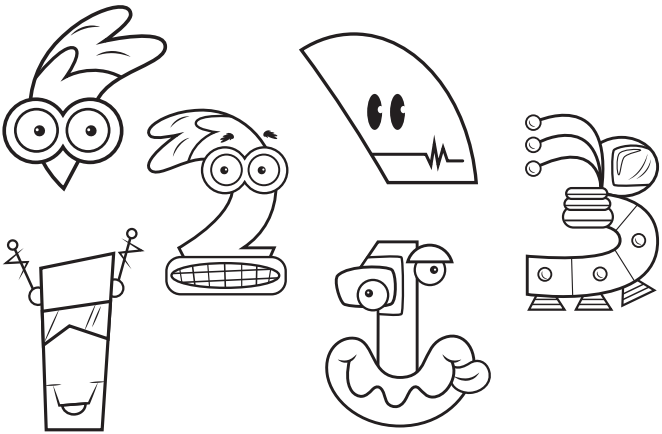

6 7 8 9

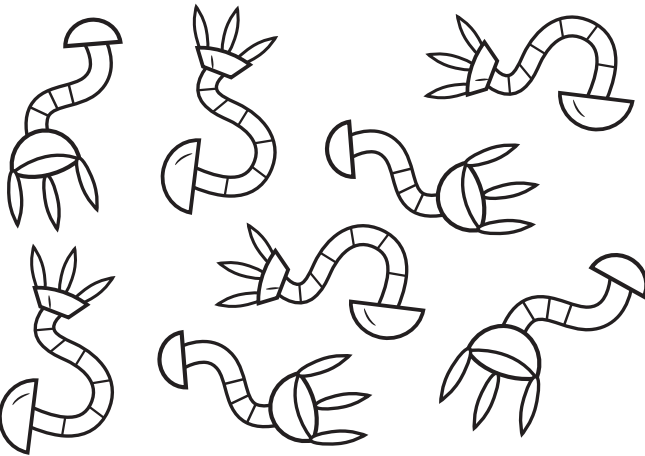

6 7 8 9

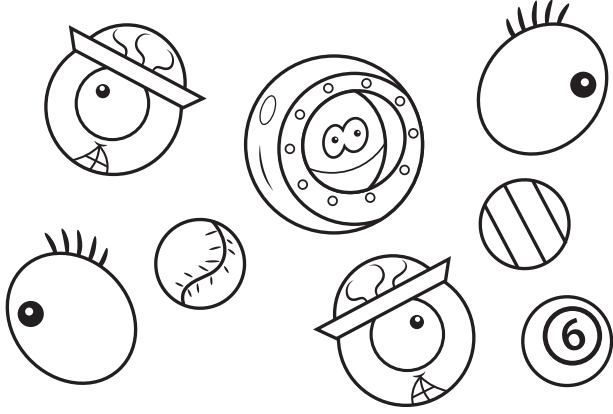

6 7 8 9

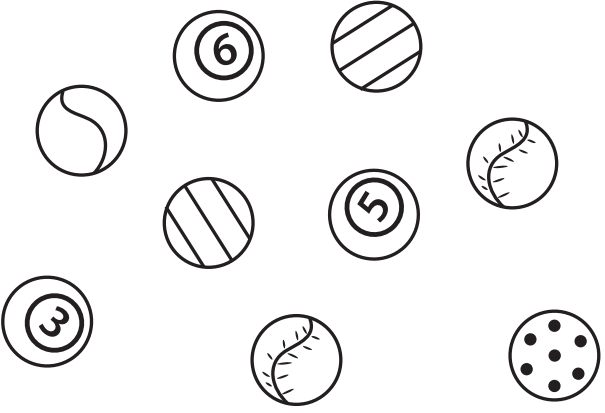

6 7 8 9

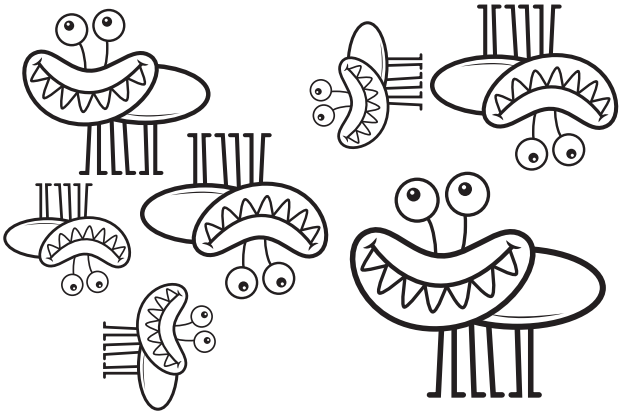

6 7 8 9

Circle the correct number.

Name \_\_\_\_\_

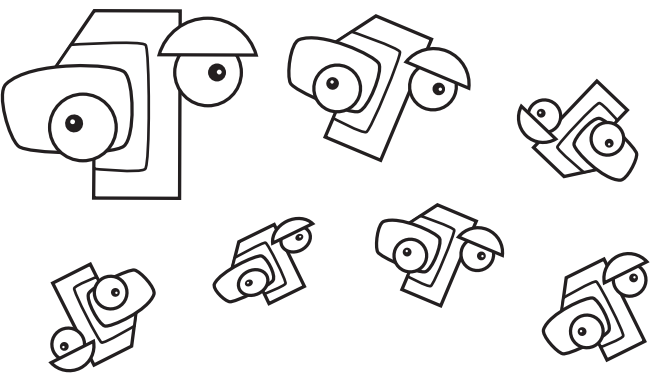

7 8 9 10

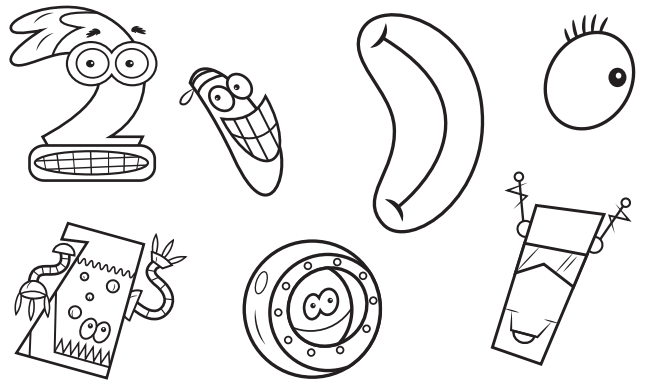

7 8 9 10

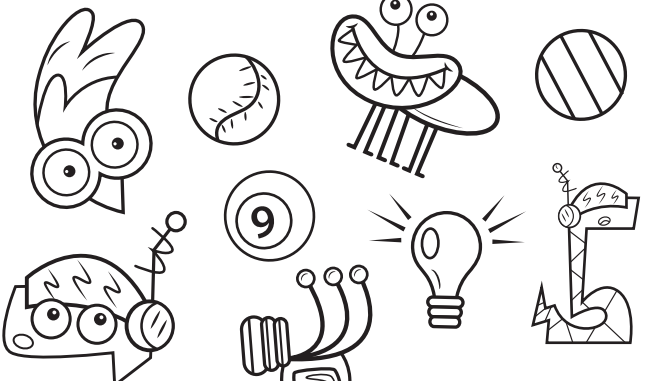

7 8 9 10

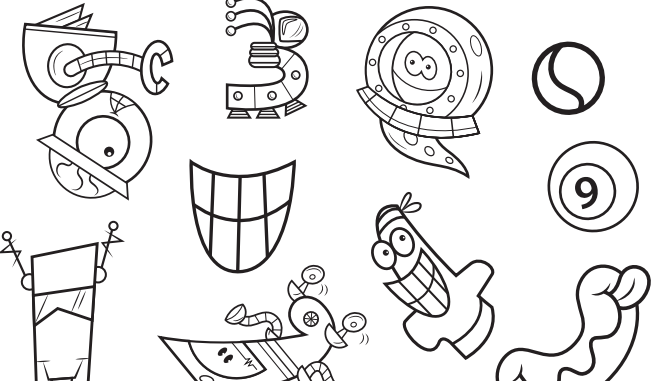

7 8 9 10

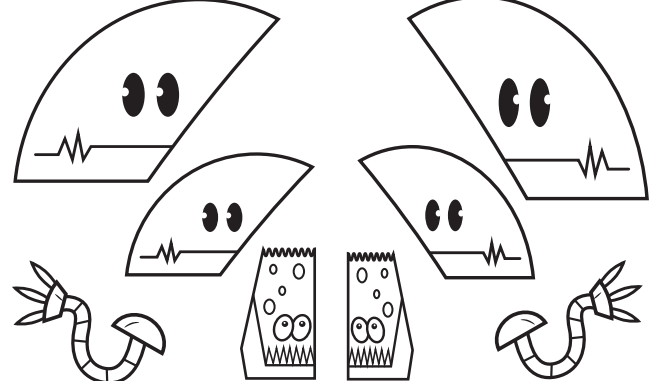

7 8 9 10

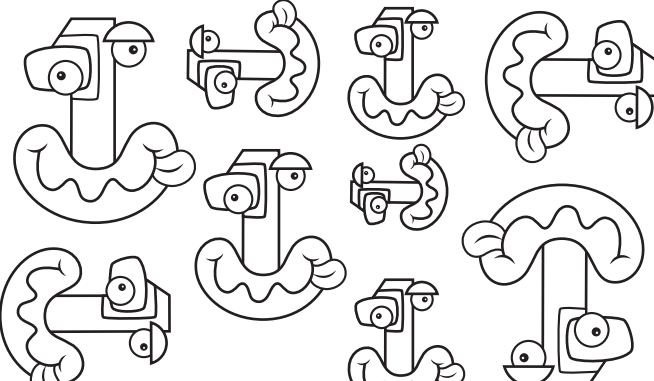

7 8 9 10

Find the sets of SIX items.  
Cut and paste them next  
to the Creature, then color.

Name \_\_\_\_\_

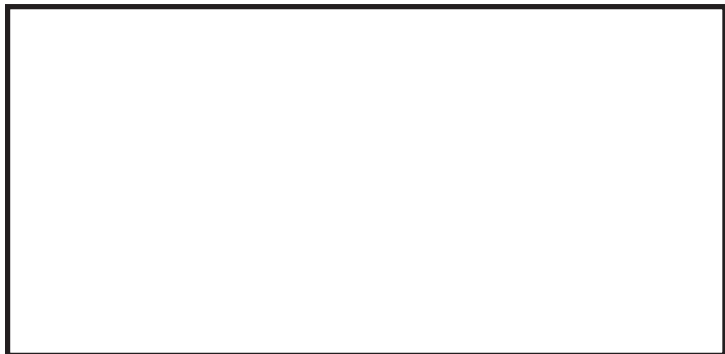
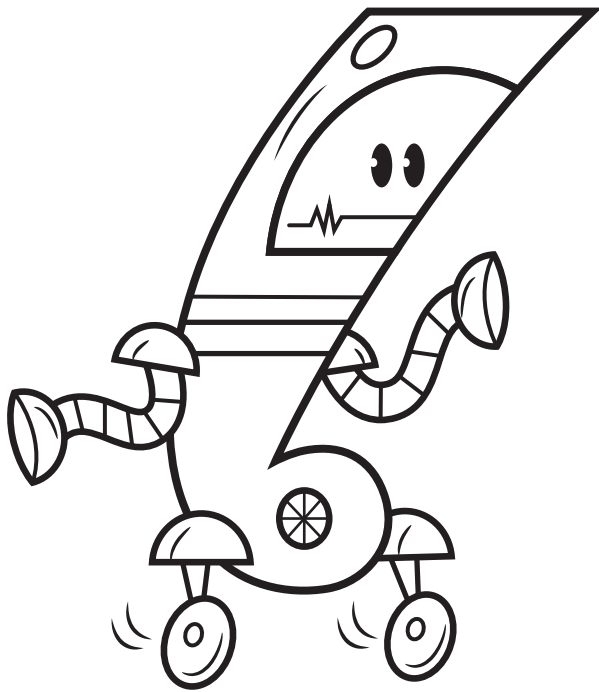

six 6 six

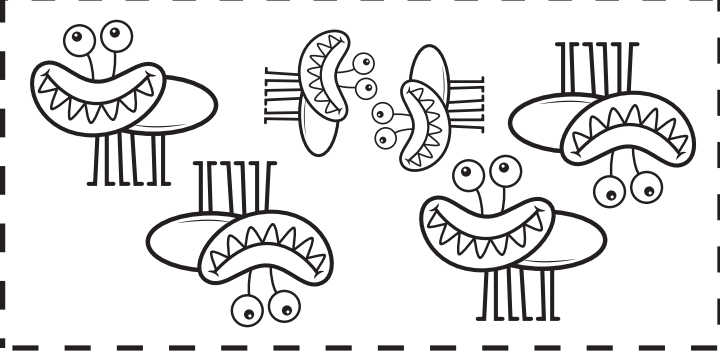
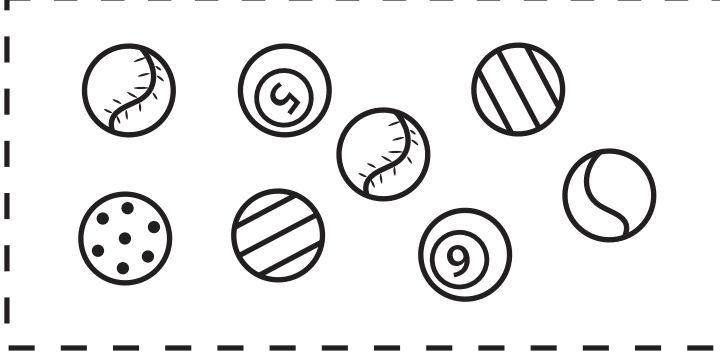
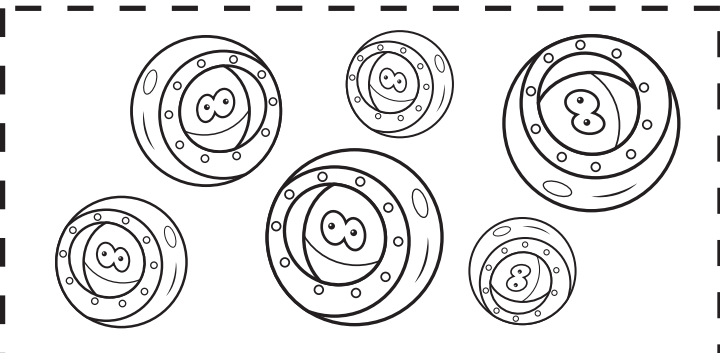
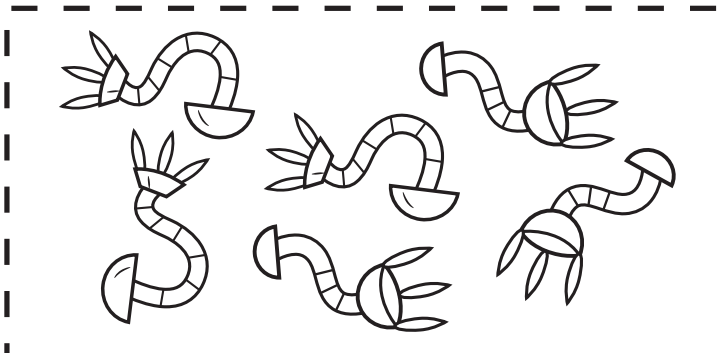

Find the sets of SEVEN items.

Name \_\_\_\_\_

Cut and paste them next to the Creature, then color.

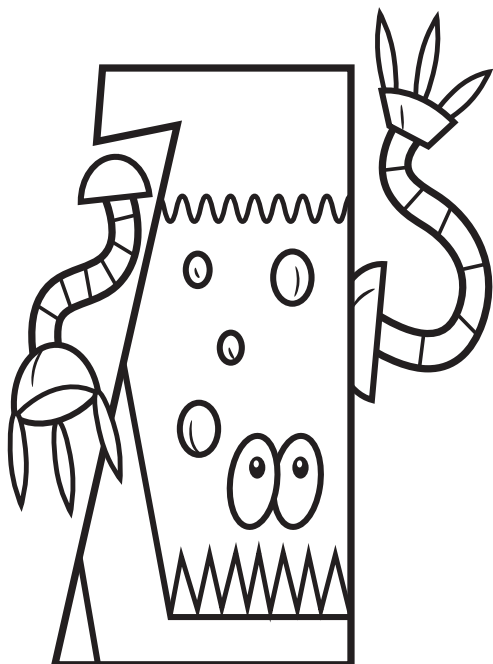

seven 7

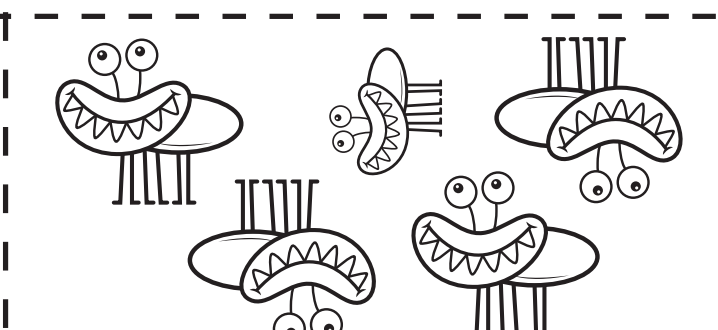
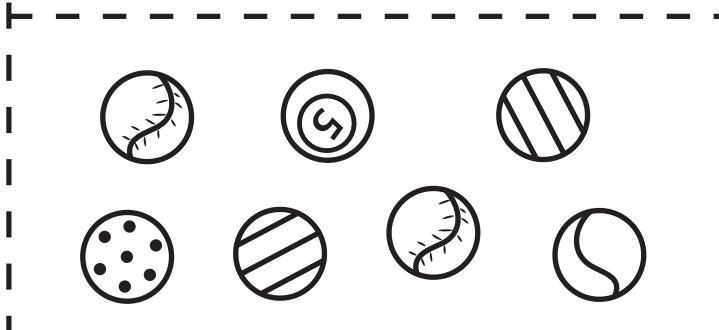
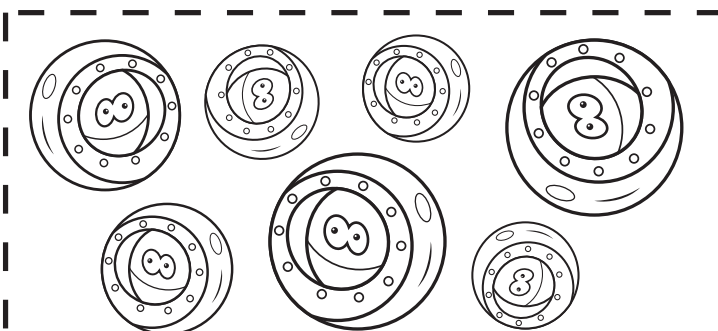
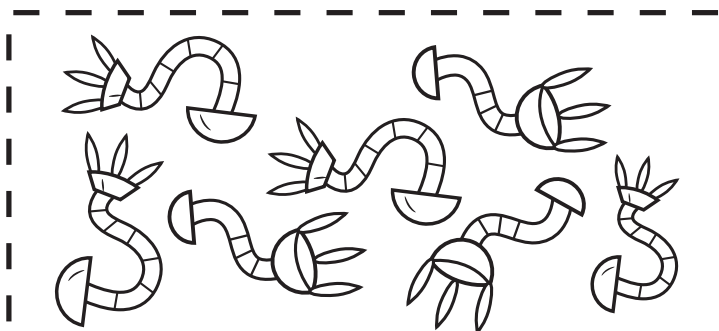



Find the sets of EIGHT items.

Name \_\_\_\_\_

Cut and paste them next to the Creature, then color.



eight 8

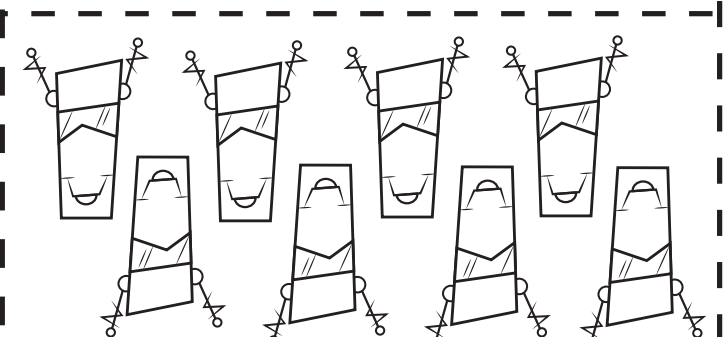
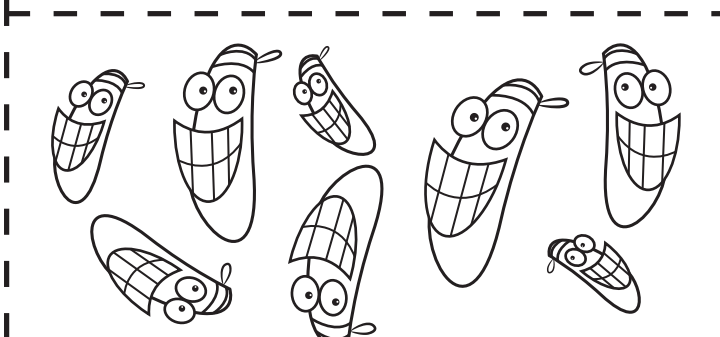
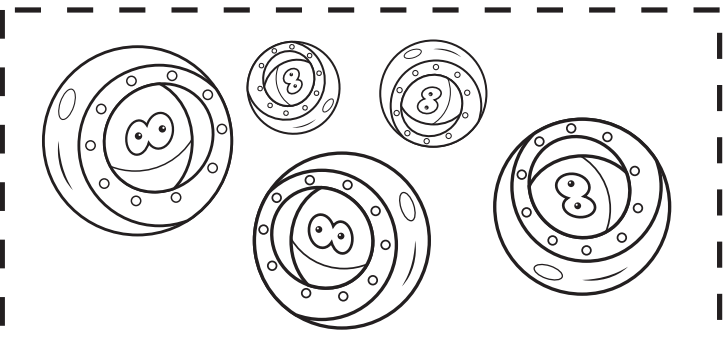
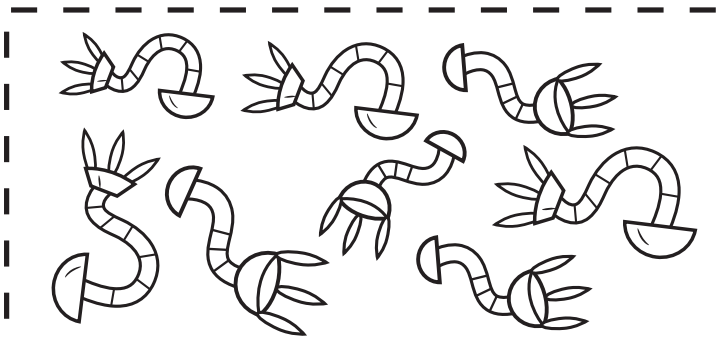

Draw and color EIGHT items. Name \_\_\_\_\_

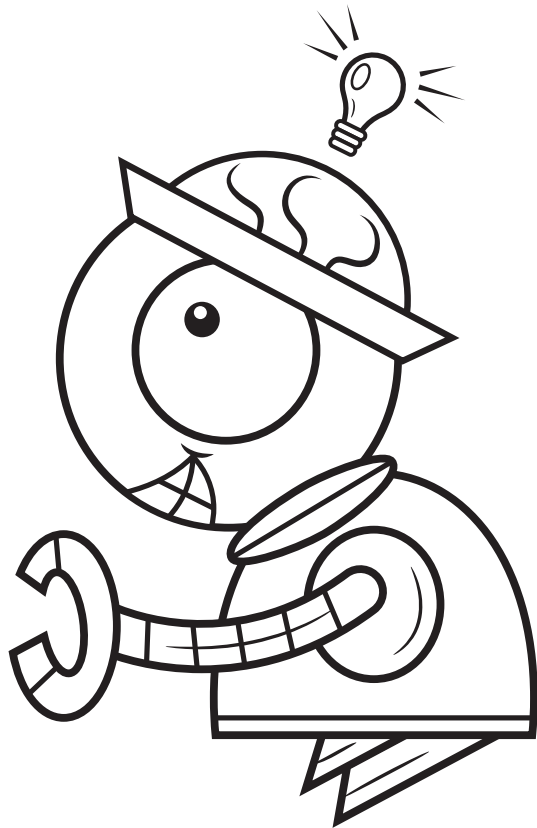

8 eight 8

8 eight 8

8 eight 8

Draw and color NINE items.

Name \_\_\_\_\_

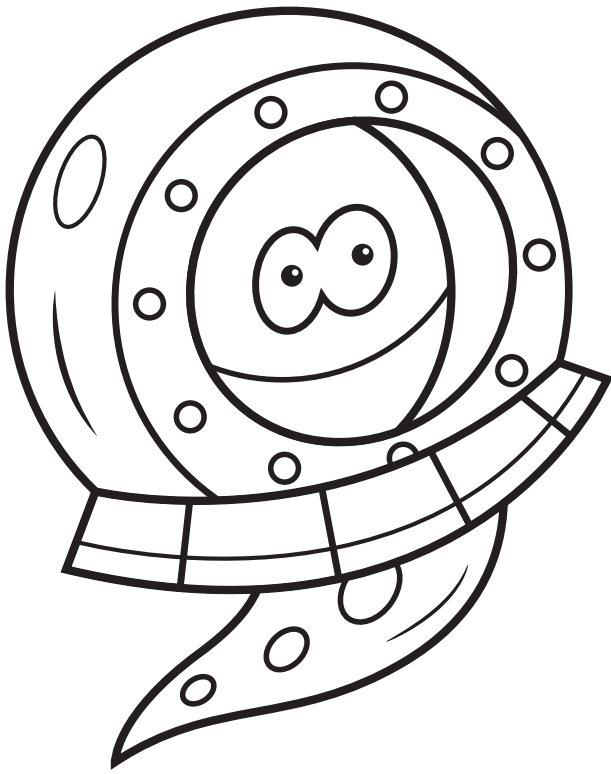

\_\_\_\_\_

nine 9 nine

\_\_\_\_\_

nine 9 nine

\_\_\_\_\_

9 nine 9

Draw and color TEN items.

Name \_\_\_\_\_

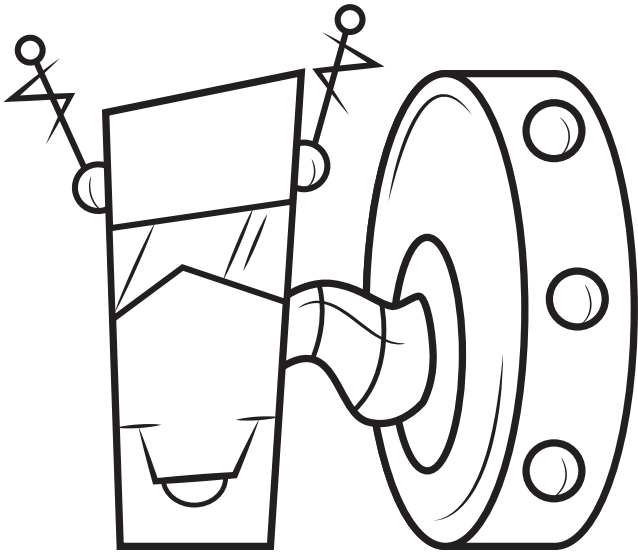

ten 10 ten

ten 10 ten

10 ten 10

Draw the right number of bows.

Name \_\_\_\_\_

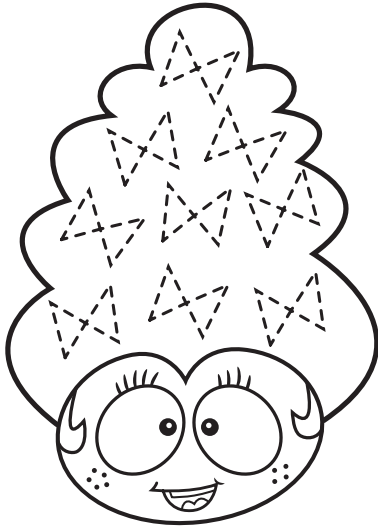

9 bows

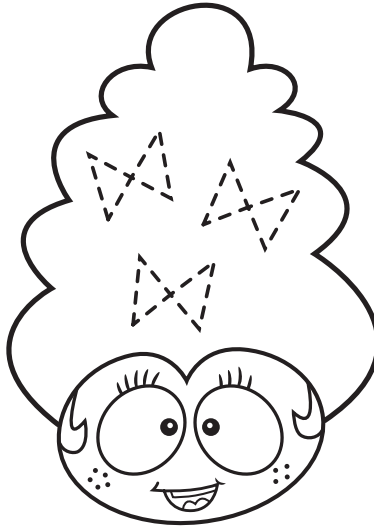

3 bows

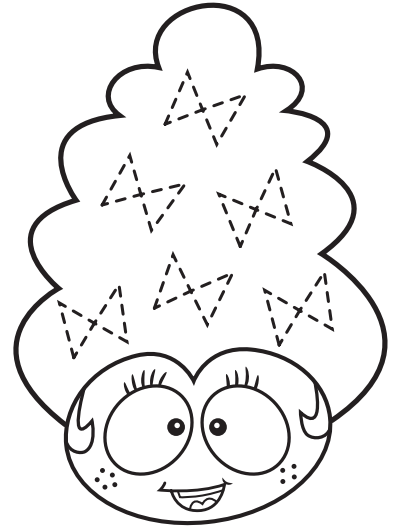

6 bows

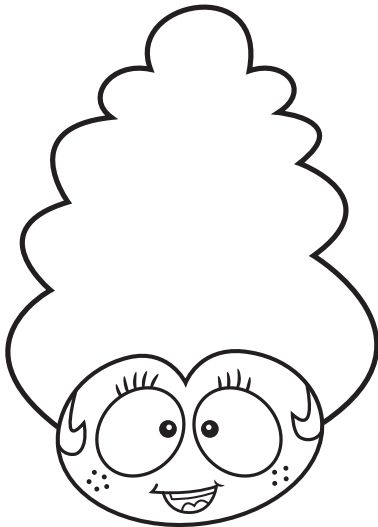

8 bows

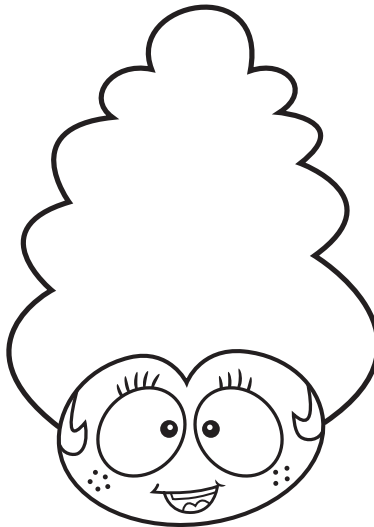

4 bows

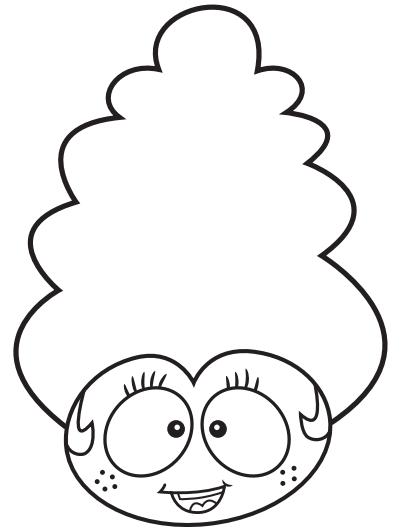

7 bows

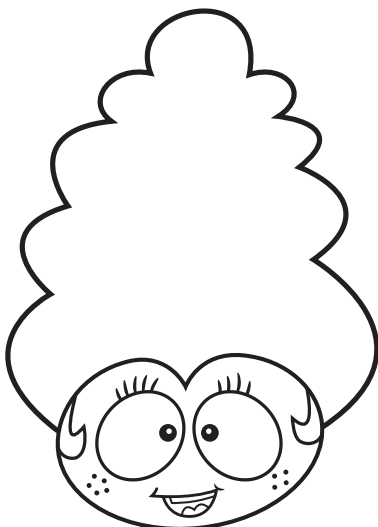

5 bows

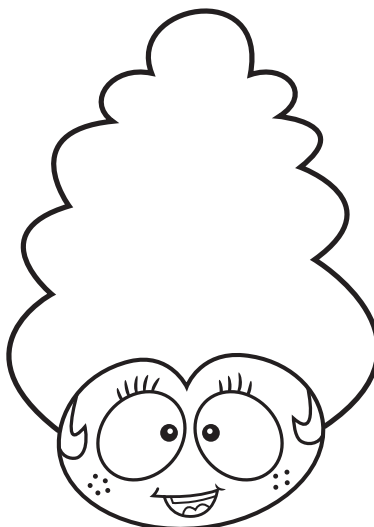

9 bows

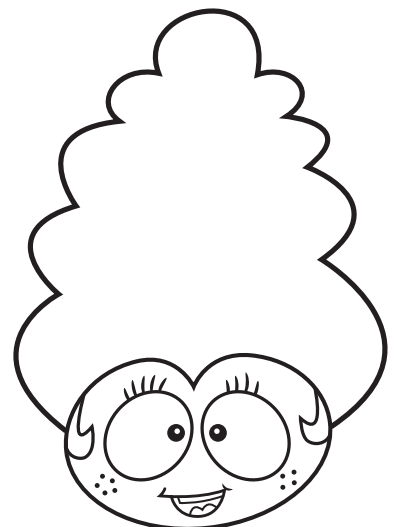

6 bows

Draw the right number of bows.

Name \_\_\_\_\_

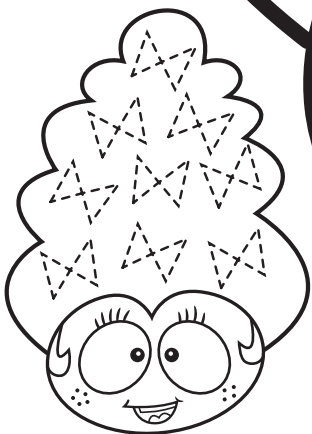
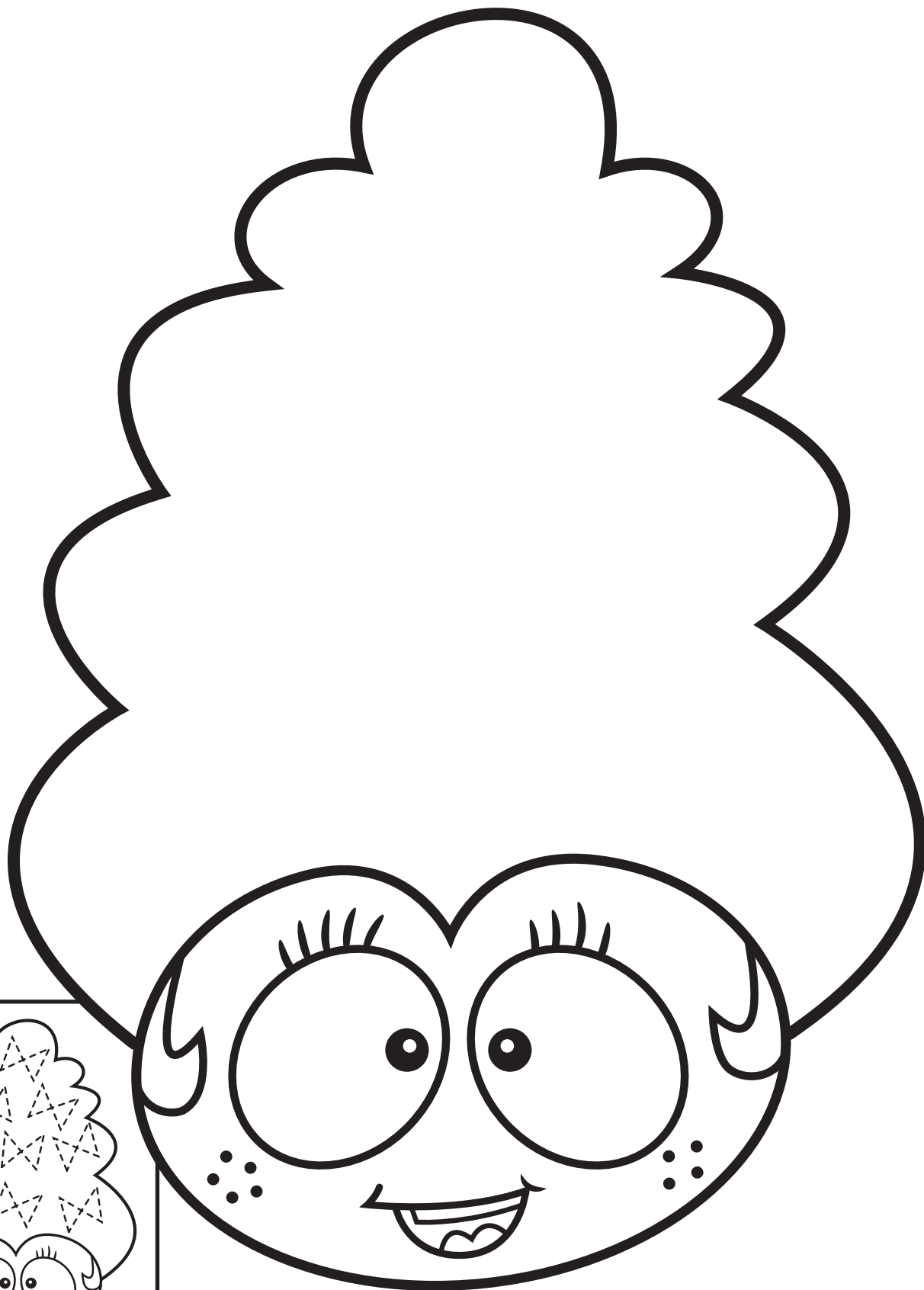



Draw the right number of bumps. Name \_\_\_\_\_

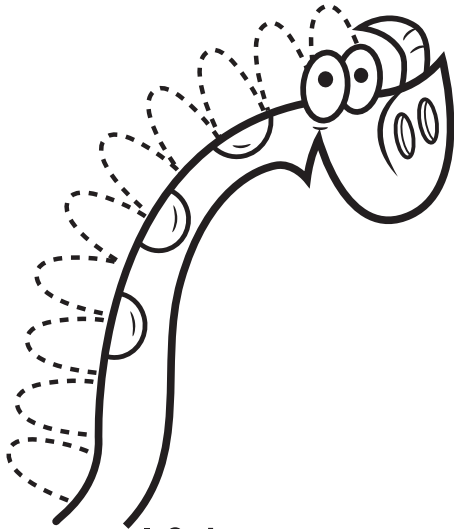

10 bumps

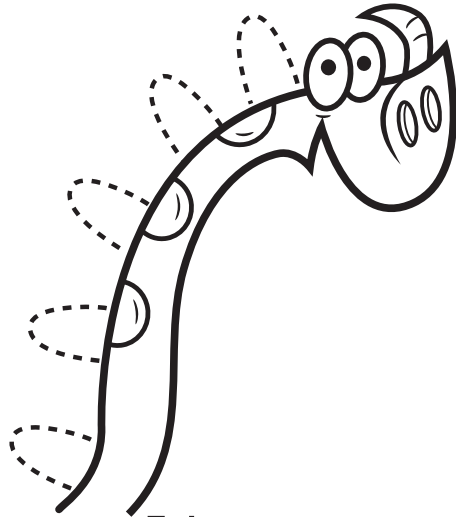

5 bumps

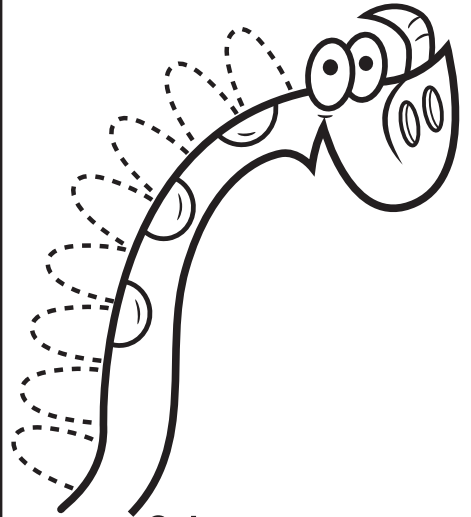

8 bumps

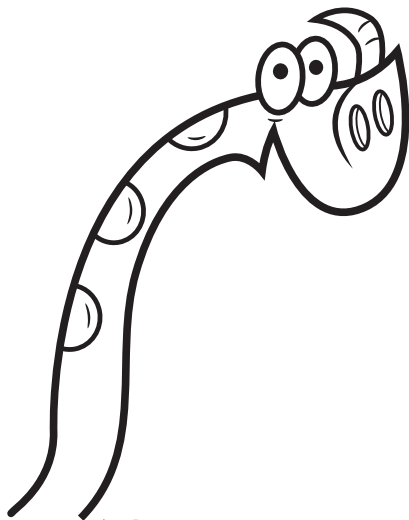

6 bumps

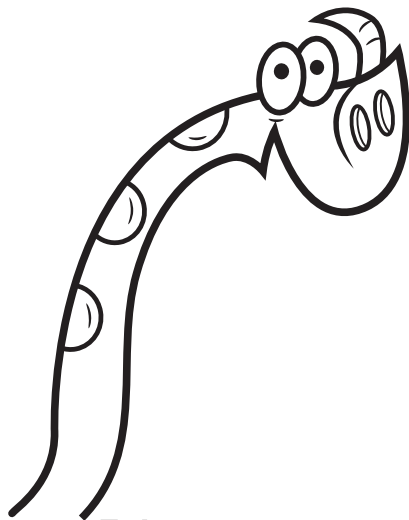

5 bumps

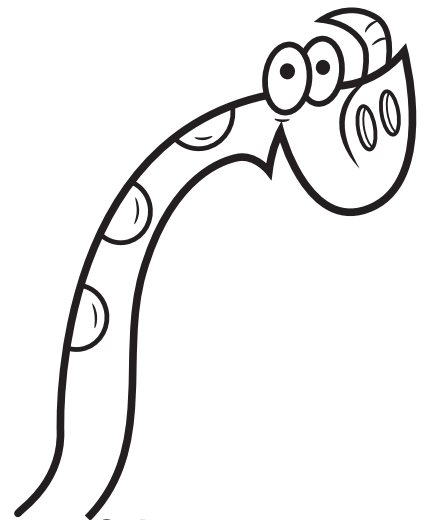

9 bumps

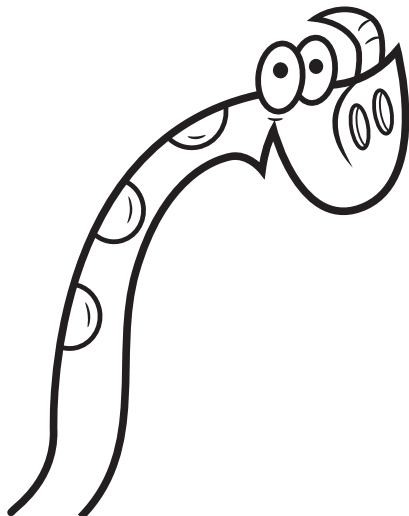

8 bumps

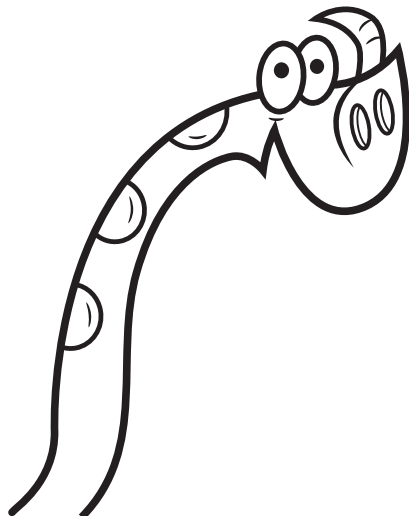

10 bumps

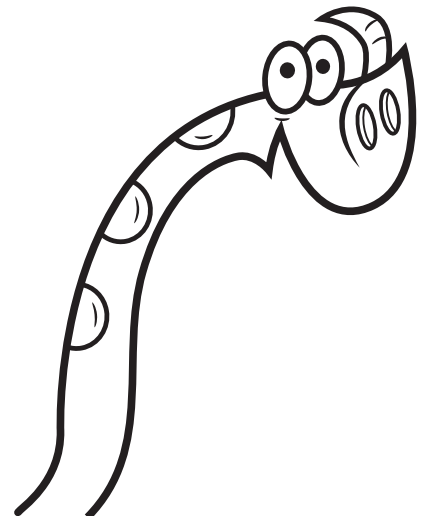

7 bumps

Draw the right number of bumps.

Name \_\_\_\_\_

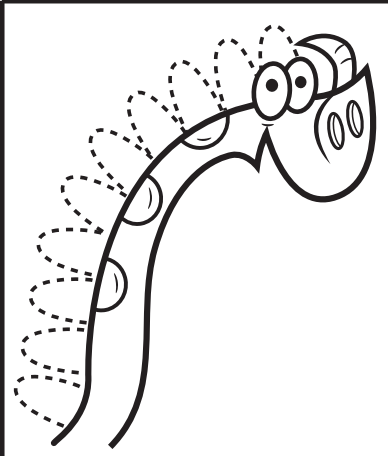
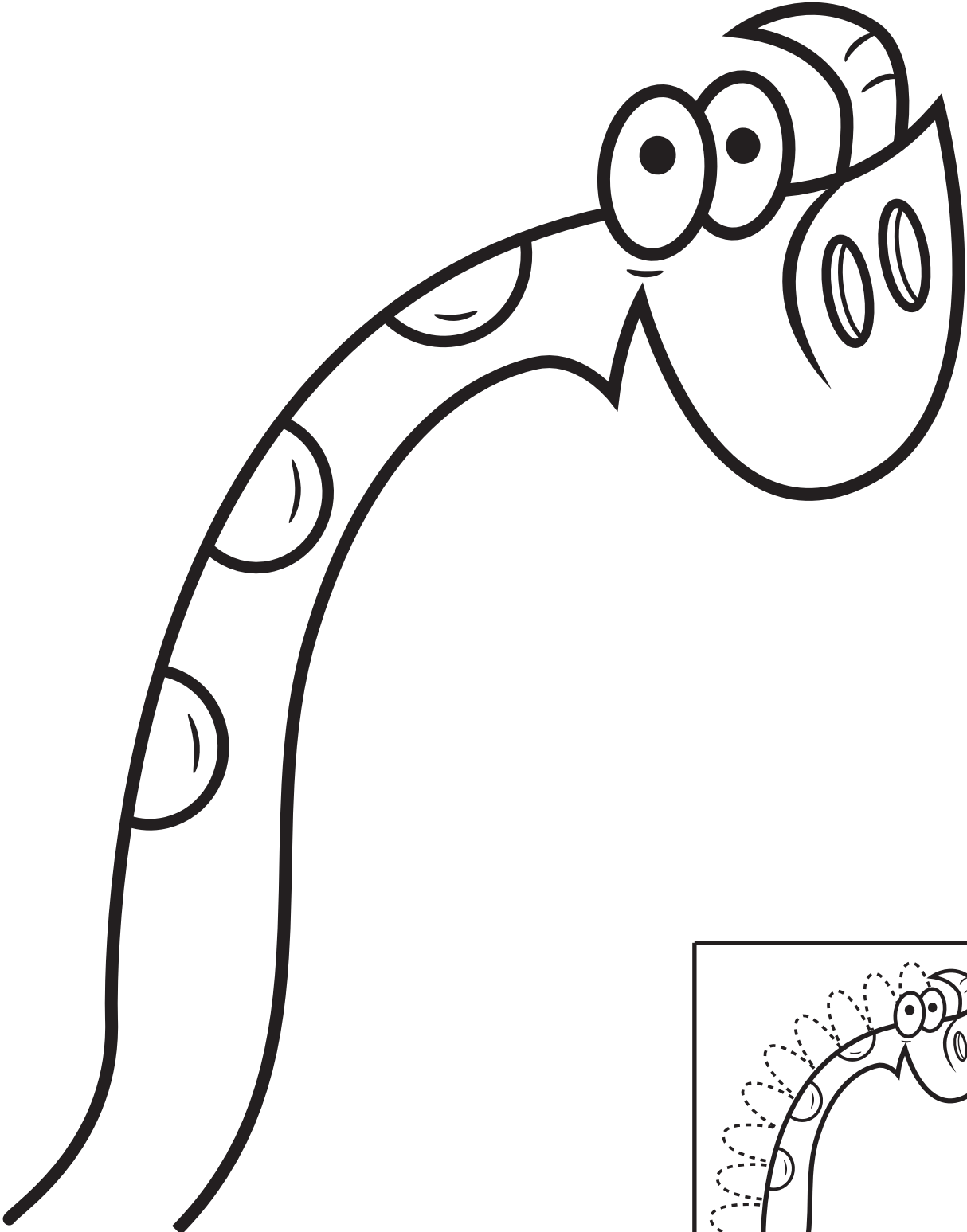

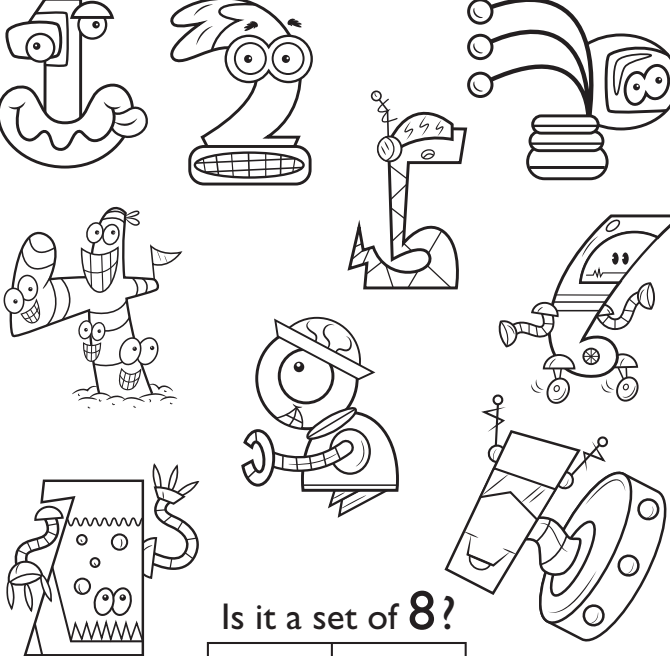

Count and Color **8** items.

Name \_\_\_\_\_



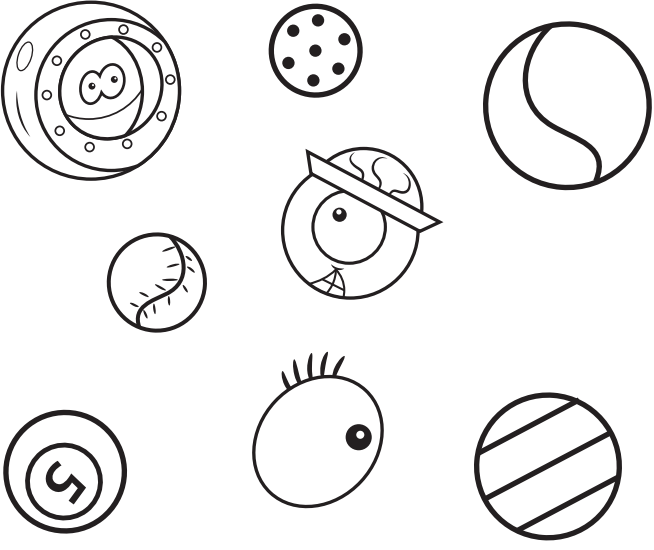

Is it a set of **8**?

	
Yes	No



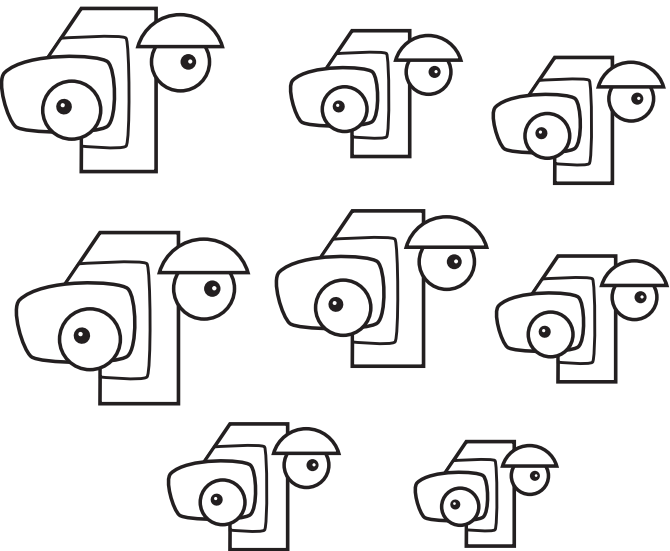

Is it a set of **8**?

	
Yes	No





Is it a set of **8**?

	
Yes	No



Is it a set of **8**?

	
Yes	No

# Count and Color 10 items.

Name \_\_\_\_\_

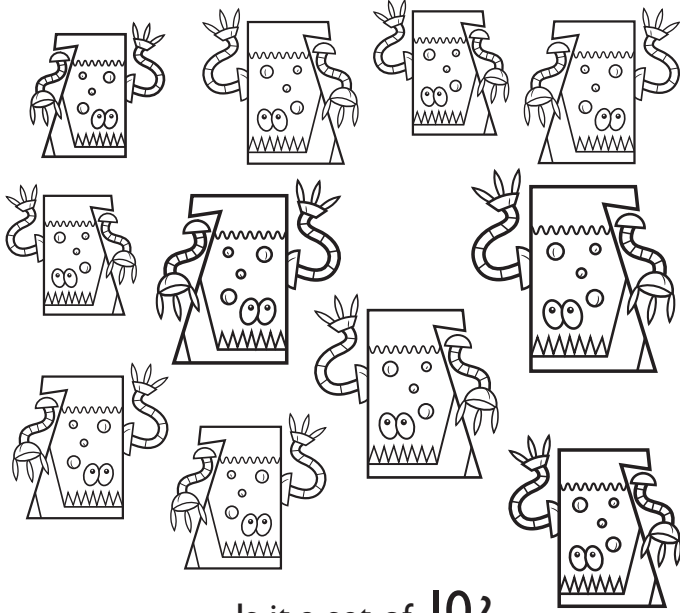

Is it a set of 10?

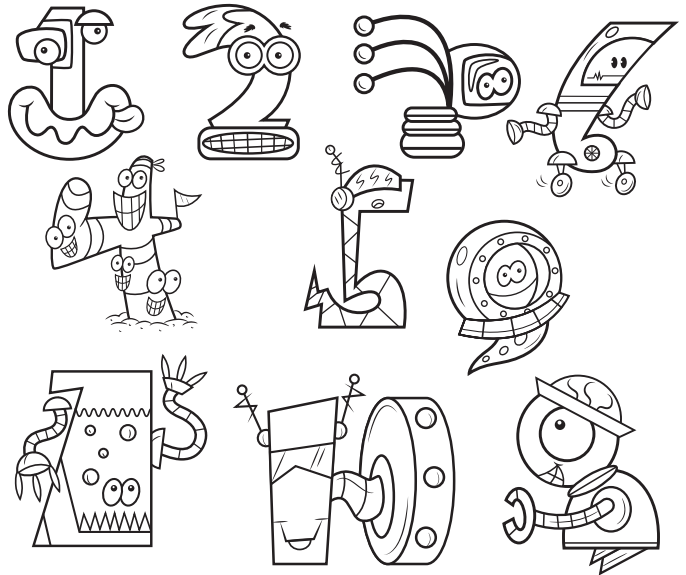
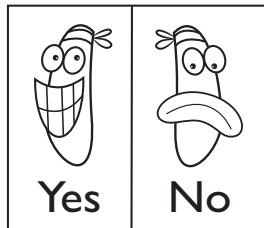

Is it a set of 10?

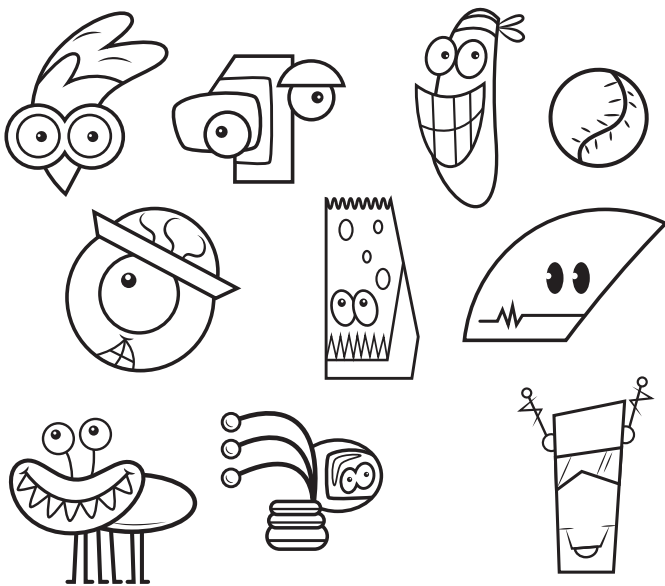
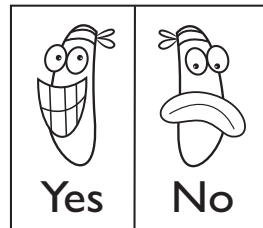

Is it a set of 10?

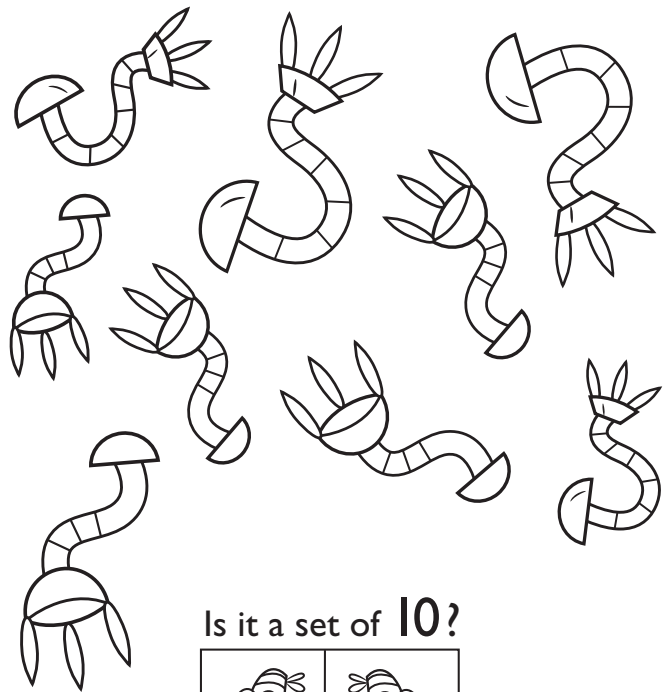
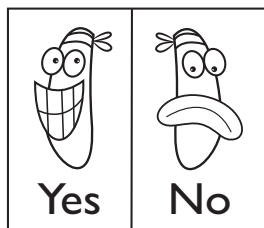

Is it a set of 10?

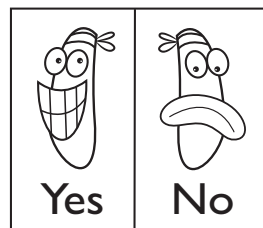

[www.HeidiSongs.com](http://www.HeidiSongs.com)  
P.O. Box 603, La Verne, CA 91750  
(909) 331-2090

©2011 Heidi Butkus • [Heidi@heidisongs.com](mailto:Heidi@heidisongs.com)  
Illustrations by Korey Scott ©2011 Heidisongs  
[www.koreyscott.com](http://www.koreyscott.com)