

September 29, 2008

The Honorable Kimberly D. Bose
Secretary
Federal Energy Regulatory Commission
888 First Street NE
Washington, DC 20426

RE: *Southwest Power Pool, Inc.*, Docket No. ER08-_____
Submission of Large Generator Interconnection Agreement

Dear Secretary Bose:

Pursuant to section 205 of the Federal Power Act, 16 U.S.C. § 824d, and section 35.13 of the Federal Energy Regulatory Commission's ("FERC" or "Commission") regulations, 18 C.F.R. § 35.13, Southwest Power Pool, Inc. ("SPP") submits an executed Large Generator Interconnection Agreement ("LGIA") between SPP as Transmission Provider, Southwestern Public Service Company (d/b/a Xcel Energy) ("Xcel Energy") as Transmission Owner, and East Guymon Wind LLC ("East Guymon") as Interconnection Customer ("East Guymon LGIA").¹ The East Guymon LGIA modifies an existing LGIA between the same parties designated as Service Agreement No. 1056 ("Original East Guymon LGIA"). SPP is submitting the East Guymon LGIA for filing because it includes language and terms and conditions that do not conform to the *pro forma* LGIA in SPP's Open Access Transmission Tariff ("OATT" or "Tariff").² In addition, as explained below, SPP also is submitting the Original East Guymon LGIA, as it includes some provisions that the Commission may consider to be non-conforming with SPP's *pro forma* LGIA.

I. Background

On November 29, 2004, the parties entered into the Original East Guymon LGIA, which provided for the interconnection of East Guymon's 150 MW wind energy generation facility ("Facility"), located approximately three miles east of Guymon, Oklahoma, to Xcel Energy's transmission system. The Facility will consist of 100 General Electric wind turbines with a nominal output of 150 MW that will be interconnected through a 115 kV transmission line tied to the Texas County Interchange.

¹ A copy of the East Guymon LGIA, which is designated as First Revised Service Agreement No. 1056, is attached as Exhibit I to this transmittal letter.

² See SPP Tariff at Attachment V, Appendix 6.

FILED
SECRETARY OF THE
COMMISSION
2008 SEP 29 P 4:47
FEDERAL ENERGY
REGULATORY COMMISSION

SPP has reported the Original East Guymon LGIA in its Electric Quarterly Reports (“EQRs”) commencing with its fourth quarter 2004 EQR. On February 11, 2005, East Guymon notified SPP and the Transmission Owner that it would be suspending its interconnection request pursuant to Section 5.16 of the Original East Guymon LGIA.³ On February 7, 2008, East Guymon notified SPP and Xcel Energy of its intention to reinstate the East Guymon LGIA.

On August 14, 2008, SPP sent to East Guymon and Xcel Energy a Letter Agreement proposing various modifications to the Appendices of the Original East Guymon LGIA as a result of changing circumstances during the suspension period.⁴ The Letter Agreement was executed by East Guymon on August 21, 2008 and by Xcel Energy on August 28, 2008. The modifications set forth in the Letter Agreement are incorporated into the East Guymon LGIA filed herein.

II. Descriptions and Justification of Non-Conforming Provisions Included in the East Guymon LGIA

The East Guymon LGIA is identical to the Original East Guymon LGIA except for the modifications to the Appendices agreed to by the parties in the Letter Agreement. As explained in the Letter Agreement, (i) Appendix A to the Original East Guymon LGIA is revised to update cost estimates that have changed during the suspension period; (ii) Appendix B is revised to update milestones; (iii) Appendix C is revised to reflect specific changes in the project; (iv) Appendix D is revised to reflect minor administrative edits; and (v) Appendices E and F are revised to update contact information.⁵ The revisions to the Original East Guymon LGIA reflected in the East Guymon LGIA are necessary as a result of changing circumstances during the suspension period.

As mentioned above, SPP is filing the East Guymon LGIA because it contains modifications that, while largely consistent with the terms and conditions of the *pro forma* LGIA, do not completely conform to SPP’s *pro forma* LGIA form set forth in

³ See *pro forma* LGIA at Section 5.16 (allowing Interconnection Customer to suspend its interconnection request for a period not to exceed three years). In addition, to date, in accordance with the SPP’s Large Generator Interconnection Procedures (“LGIP”), East Guymon only has paid for financial security and study costs with regard to its interconnection request. See SPP Tariff at Attachment V, Section 7.2 (requiring Interconnection Customers to execute an ISISA and submit a deposit).

⁴ A copy of the Letter Agreement is attached in Exhibit III to this transmittal letter.

⁵ Exhibit III, Letter Agreement at 1.

Attachment V, Appendix 6 of SPP's Tariff. Specifically, the non-conforming language in the Appendices of the East Guymon LGIA includes the following:⁶

A. Appendix A:

(i) Appendix A includes a note that specifies that the facilities described therein are based on studies conducted in response to East Guymon's interconnection request, and that in the event other interconnection customers suspend, terminate or request unexecuted filings of their LGIAs, additional studies may be required that could result in changes to the Interconnection Facilities and Network Upgrades, as well as to East Guymon's cost obligation for those facilities. This note puts East Guymon on notice that if another interconnection customer terminates its interconnection request, including terminating at the end of a suspension period, or in the event another interconnection customer's unexecuted LGIA is not accepted by the Commission and thus it is withdrawn from the queue, SPP may conduct restudies to re-evaluate East Guymon's cost obligation. This note informs East Guymon of termination conditions that may lead to restudies.⁷

(ii) Paragraphs (a) and (b) of sections 1 and 2 of Appendix A contain language specifying cost responsibility, the total estimated costs, and ownership of the various interconnection facilities. These provisions are consistent with the provisions of the *pro forma* LGIA.⁸ Additionally, the

⁶ Redlined pages showing the non-conforming provisions in the Appendices of the East Guymon LGIA are included as Exhibit II to this transmittal letter.

⁷ *Midwest Indep. Transmission Sys. Operator, Inc.*, 109 FERC ¶ 61,085, at P 37 (2004) ("the Interconnection Customer is responsible (and later may receive credits) for funding the cost of, among other things, Network Upgrades that originally were the responsibility of a higher queued Interconnection Customer that dropped out of the queue, if these Network Upgrades are necessary to support the interconnection of the Interconnection Customer's Generating Facility."); see also *Neptune Reg'l Transmission Sys., LLC v. PJM Interconnection, L.L.C.*, 110 FERC ¶ 61,098, at P 24, *reh'g denied*, 111 FERC ¶ 61,455 (2005), *aff'd sub nom. Pub. Serv. Elec. and Gas Co. v. FERC*, 485 F.3d 1164 (D.C. Cir. 2007) (when interconnection customer enters queue, it becomes "responsible for . . . the costs of any reconfiguration arising from higher-queued projects withdrawing from consideration.").

⁸ See *pro forma* LGIA at Sections 11.1 and 11.2 (providing that Interconnection Customer and Transmission Provider/Transmission Owner, respectively, will, at the expense of the Interconnection Customer, design, procure, construct, own and install their respective interconnection facilities).

Commission recently approved revisions to SPP's *pro forma* LGIA specifying that it is the Transmission Owner (Xcel Energy in this case) and not the Transmission Provider (SPP) that will be responsible for designing, procuring, and constructing the Transmission Owner's interconnection facilities.⁹ Because the proposed language in Appendix A makes a similar distinction by specifying that the Transmission Owner will be the entity responsible for designing, procuring, constructing, owning and installing its interconnection facilities, it is consistent with Commission precedent and thus just and reasonable.

(iii) Section 2 of Appendix A has been further modified to include three additional paragraphs (e), (f) and (g). Paragraph (e) indicates that the cost of the transmission owner interconnection facilities to be constructed by East Guymon is \$0. Paragraph (f) specifies: (a) the total estimated cost of Xcel Energy's interconnection facilities to be constructed by Xcel Energy at East Guymon's expense; (b) that payment of such costs will be pursuant to the milestones in Appendix B; (c) the methodology for estimating the costs; and (d) that the total costs and expenses will be trued up in accordance with Article 12.2. Paragraph (g) indicates that the portion of the Network Upgrades that is subject to transmission credits is estimated at \$0.¹⁰

(iv) Appendix A has also been modified from the *pro forma* LGIA form to include additional sections 4 (Interconnection Service: Interconnection Service), 5 (Construction Option Selected by Interconnection Customer), 6 (Eligible Network Customers) and 7 (Licenses and Permits). As explained below, the information contained in these new sections is largely consistent with the provisions of the *pro forma* LGIA:

- a) Section 4 is consistent with section 4.1 of the *pro forma* LGIA, which details the interconnection product options to be selected by the Interconnection Customer (Energy Resource Interconnection Service or Network Resource Interconnection Service). Sections

⁹ See *Sw. Power Pool, Inc.*, 122 FERC ¶ 61,060, at P 12 (2008) (accepting SPP's proposed revisions reflecting different responsibilities of Transmission Owner and Transmission Provider) ("LGIA Revision Order").

¹⁰ Paragraph G is consistent with, and merely elaborates on, section 11.4 of the *pro forma* LGIA, which addresses transmission credits. Section 2 of Appendix A also contains additional paragraphs (c) (Joint Network Upgrades) and (d) (Previous Network Upgrades). These paragraphs merely indicate that there are no such upgrades.

4.1.1.1 and 4.1.2.1 of the *pro forma* LGIA specifically provide that additional information will be provided in Appendix A.

- b) Section 5 is consistent with section 5.1 of the *pro forma* LGIA, which specifies the construction options to be selected by the Interconnection Customer, and similarly provides that additional information will be reflected in Appendix A.
- c) Section 7 is consistent with section 5.14 of the *pro forma* LGIA, which provides that the agreement will specify “the allocation of the responsibilities of [the] Transmission Provider or Transmission Owner and Interconnection Customer to obtain all permits, licenses and authorizations that are necessary to accomplish the interconnection in compliance with Applicable Laws and Regulations.” The language in section 7 of Appendix A serves to specify such allocation of responsibilities.

(v) Appendix A also includes one-line diagrams illustrating the interconnection and identifying the point of interconnection. These one-line diagrams provide detail regarding the interconnection, which provides necessary information to the parties. Figure A-1 provides detailed information of the electrical characteristics of the requester’s (Interconnection Customer’s) substation, identifies the requester’s transmission line and the demarcation between the requester’s equipment and the Transmission Owner’s equipment. Figure A-1 provides an overview of the point of interconnection and the change of ownership. Figure A-2 provides the specific information for the point of interconnection and the change of ownership identified on the interconnection customer’s self-supporting dead-end structure.

B. Appendix D

Language has been added to Appendix D of the East Guymon LGIA providing that the parties will cooperate reasonably to comply with and implement the recommendations of the President’s Critical Infrastructure Protection Board and any best practice recommendations from the electric reliability authority. A communications schematic diagram also is included to assist the parties in meeting these standards. These additional provisions are consistent with Article 8 of the *pro forma* LGIA, which addresses the communications requirements for the parties.¹¹

¹¹ In addition, various minor clerical revisions have been made to Appendix E *pro forma* language updating the position titles and addresses, and modifying how the Facility is referenced (wind generating facilities do not have unit numbers). Moreover, Appendix G of SPP’s current *pro forma* LGIA is not included in the East Guymon LGIA, as it was not

SPP notes that, while Appendices A-F of the Original East Guymon LGIA have been modified, SPP has nonetheless maintained the remainder of the Original East Guymon LGIA. This is consistent with Commission precedent. Specifically, the Commission has recognized that interconnection agreements that do not propose increases in capacity or material modifications of the characteristics of the existing generating facility do not constitute new interconnection requests and thus do not have to conform to a transmission provider's current *pro forma* interconnection agreement.¹² The revisions to the Original East Guymon LGIA reflected in the East Guymon LGIA will not "have a material impact on the cost or timing of any Interconnection Request with a later queue priority date,"¹³ nor are they a result of a request for an increase in capacity or material modification to the characteristics of the Facility. Thus they do not constitute new interconnection requests.

III. Original East Guymon LGIA

In addition, out of an abundance of caution, SPP is including in this filing (as Exhibit IV) a clean copy of the Original East Guymon LGIA (Service Agreement No. 1056). SPP is submitting the Original East Guymon because it includes some of the same provisions that are included in the Appendices to the East Guymon LGIA.¹⁴ Indeed, the language in the Appendices to the Original East Guymon LGIA and the East Guymon LGIA is identical, except as indicated in the Letter Agreement and reflected on the redlined sheets included as Exhibit V. As described above, the non-conforming language in the Appendices of the LGIAs is largely consistent with the *pro forma* LGIA and is necessary to accommodate the East Guymon interconnection. Furthermore, SPP has reported the Original East Guymon LGIA in its EQR since its fourth quarter 2004 EQR.

included in the *pro forma* LGIA as of the effective date of the Original East Guymon LGIA that is being modified (see discussion above).

¹² See *Midwest Indep. Transmission Sys. Operator, Inc.*, 122 FERC ¶ 61,019, at P 20 (2008) ("We note that not all changes to existing or planned generating facilities require new [interconnection agreement]s"); *New Eng. Power Co.*, 109 FERC ¶ 61,364, at P 13 (2004) (discussing how agreements that do not propose increases in capacity or material modifications of the characteristics of an existing generating facility do not constitute new interconnection requests).

¹³ See LGIA at Article 1 (definition of Material Modification).

¹⁴ The Original East Guymon LGIA includes similar modifications in Appendices A, D and G.

IV. Effective Date and Waiver

SPP requests an effective date of August 28, 2008 for the East Guymon LGIA. Pursuant to section 35.11 of the Commission's rules and regulations, 18 C.F.R. § 35.11, SPP requests a waiver of the Commission's 60-day notice requirement set forth at 18 C.F.R. § 35.3. Waiver is appropriate because all parties agree to the effective date and the LGIA is being filed no later than 30 days after the commencement of service.¹⁵

To the extent necessary, SPP requests an effective date of November 29, 2004 for the Original East Guymon LGIA. Waiver is appropriate because much of the non-conforming language in the Original East Guymon LGIA is consistent with the *pro forma* LGIA, the Original East Guymon LGIA has been reported in SPP's EQR since the fourth quarter 2004 EQR, and East Guymon has made no payments for the construction of interconnection facilities pursuant to the East Guymon LGIA.¹⁶

V. Additional Information

A. Information Required by Section 35.13 of the Commission's Regulations, 18 C.F.R. § 35.13:

(1) Documents submitted with this filing:

Included with this transmittal letter are the following: (a) a clean copy of the LGIA, as Exhibit I; (b) a redlined copy of the LGIA, as Exhibit II; (c) a copy of the Letter Agreement between the parties to the East Guymon LGIA, as Exhibit III; (d) a clean copy of the Original East Guymon LGIA, as Exhibit IV; and (e) redlined pages illustrating the differences between the Original East Guymon LGIA and the East Guymon LGIA, as Exhibit V.

(2) Effective Date:

As discussed herein, SPP respectfully requests that the Commission accept the East Guymon LGIA with an effective date of August 28, 2008, and to the extent necessary, the Original East Guymon LGIA with an effective date of November 29, 2004.

¹⁵ See *Prior Notice Filing Requirements Under Part II of the Federal Power Act*, 64 FERC ¶ 61,139, at 61,983-84, *order on reh'g*, 65 FERC ¶ 61,081 (1993).

¹⁶ As described in footnote 3 *supra*, the only money East Guymon has paid with regard to its interconnection request has been for financial security and study costs.

(3) **Service:**

SPP has served a copy of this filing on East Guymon and Xcel Energy.

(4) **Basis of Rate:**

All charges will be determined in accordance with SPP's Tariff.

B. Communications

Copies of this filing have been served upon all parties to the Service Agreement. Any correspondence regarding this matter should be directed to:

L. Patrick Bourne
Director – Regulatory Policy
Southwest Power Pool, Inc.
415 North McKinley, #140 Plaza West
Little Rock, AR 72205
Telephone: (501) 614-3249
Fax: (501) 664-9553
pbourne@spp.org

Barry S. Spector
Carrie L. Bumgarner
Matthew K. Segers
Wright & Talisman, P.C.
1200 G Street, NW
Suite 600
Washington, D.C. 20005
Telephone: (202) 393-1200
Fax: (202) 393-1240
spector@wrightlaw.com
bumgarner@wrightlaw.com
segers@wrightlaw.com

VI. Conclusion

For all of the foregoing reasons, SPP respectfully requests that the Commission accept the East Guymon LGIA with an effective date of August 28, 2008, and to the extent necessary, the Original East Guymon LGIA with an effective date of November 29, 2004.

Respectfully submitted,



Barry S. Spector
Carrie L. Bumgarner
Matthew K. Segers

**Attorneys for Southwest Power
Pool, Inc.**

EXHIBIT I

INTERCONNECTION AGREEMENT

entered into by the

Southwest Power Pool, Inc.,

Southwestern Public Service Company (d/b/a Xcel Energy),

And

East Guymon Wind L.L.C.

entered into on the 28th day of August; 2008

**Gen-2002-006
TABLE OF CONTENTS**

		Page
Recitals		1
Article 1.	Definitions	2
Article 2.	Effective Date, Term,, and Termination	11
2.1	Effective Date	12
2.2	Term of Agreement	12
2.3	Termination Procedures	12
2.3.1	Written Notice	12
2.3.2	Default	12
2.4	Termination Costs	12
2.5	Disconnection	13
2.6	Survival	13
Article 3.	Regulatory Filings	14
3.1	Filing	14
Article 4.	Scope of Service	14
4.1	Interconnection Product Options	14
4.1.1	Energy Resource Interconnection Service	14
4.1.1.1	The Product	14
4.1.1.2	Transmission Delivery Service Implications	14
4.1.2	Network Resource Interconnection Service	15
4.1.2.1	The Product	15
4.1.2.2	Transmission Delivery Service Implications	16
4.2	Provision of Service	18
4.3	Performance Standards	18
4.4	No Transmission Delivery Service	18
4.5	Interconnection Customer Provided Services	18
Article 5.	Interconnection Facilities Engineering, Procurement, & Construction	18
5.1	Options	18
5.1.1	Standard Option	18
5.1.2	Alternate Option	19
5.1.3	Option to Build	19
5.1.4	Negotiated Option	20

5.2	General Conditions Applicable to Option to Build	20
5.3	Liquidated Damages.....	22
5.4	Power System Stabilizers	23
5.5	Equipment Procurement.....	23
5.6	Construction Commencement	23
5.7	Work Progress	24
5.8	Information Exchange.....	24
5.9	Limited Operation	24
5.10	Interconnection Customer's Interconnection Facilities ('ICIF').....	24
	5.10.1 Interconnection Customer's Interconnection Facility Specifications.....	25
	5.10.2 Transmission Provider's Review	25
	5.10.3 ICIF Construction.....	25
5.11	Transmission Provider's Interconnection Facilities Construction ...	26
5.12	Access Rights.....	26
5.13	Lands of Other Property Owners	26
5.14	Permits.....	27
5.15	Early Construction of Base Case Facilities	27
5.16	Suspension	27
5.17	Taxes	28
	5.17.1 Interconnection Customer Payments Not Taxable.....	28
	5.17.2 Representations and Covenants	28
	5.17.3 Indemnification for the Cost Consequences of Current Tax Liability Imposed Upon the Transmission Provider	29
	5.17.4 Tax Gross-Up Amount	30
	5.17.5 Private Letter Ruling or Change or Clarification of Law ...	31
	5.17.6 Subsequent Taxable Events	31
	5.17.7 Contests.....	32
	5.17.8 Refund.....	33
	5.17.9 Taxes Other Than Income Taxes	34
	5.17.10 Transmission Owners Who Are Not Transmission Providers 34	
5.18	Tax Status.....	35
5.19	Modification	35
	5.19.1 General.....	35
	5.19.2 Standards	35
	5.19.3 Modification Costs	36
Article 6.	Testing and Inspection	36
6.1	Pre-Commercial Operation Date Testing and Modifications.....	36

6.2	Post-Commercial Operation Date Testing and Modifications	36
6.3	Right to Observe Testing	36
6.4	Right to Inspect.....	37
Article 7.	Metering.....	37
7.1	General	37
7.2	Check Meters	37
7.3	Standards.....	38
7.4	Testing of Metering Equipment	38
7.5	Metering Data	38
Article 8.	Communications	38
8.1	Interconnection Customer Obligations	38
8.2	Remote Terminal Unit.....	39
8.3	No Annexation	39
Article 9.	Operations	39
9.1	General	39
9.2	Control Area Notification	40
9.3	Transmission Provider Obligations	40
9.4	Interconnection Customer Obligations	40
9.5	Start-Up and Synchronization.....	40
9.6	Reactive Power.....	41
9.6.1	Power Factor Design Criteria	41
9.6.2	Voltage Schedules.....	41
9.6.2.1	Governors and Regulators.....	41
9.6.3	Payment for Reactive Power	42
9.7	Outages and Interruptions.....	42
9.7.1	Outages.....	42
9.7.1.1	Outage Authority and Coordination	42
9.7.1.2	Outage Schedules.....	42
9.7.1.3	Outage Restoration.....	43
9.7.2	Interruption of Service	43
9.7.3	Under-Frequency and Over Frequency Conditions	44
9.7.4	System Protection and Other Control Requirements.....	45
9.7.4.1	System Protection Facilities.....	45
9.7.5	Requirements for Protection	46
9.7.6	Power Quality	46
9.8	Switching and Tagging Rules	47
9.9	Use of Interconnection Facilities by Third Parties	47
9.9.1	Purpose of Interconnection Facilities	47

	9.9.2	Third Party Users.....	47
9.10		Disturbance Analysis Data Exchange.....	47
Article 10.		Maintenance.....	48
10.1		Transmission Provider Obligations	48
10.2		Interconnection Customer Obligations	48
10.3		Coordination	48
10.4		Secondary Systems	48
10.5		Operating and Maintenance Expenses	48
Article 11.		Performance Obligation	49
11.1		Interconnection Customer Interconnection Facilities.....	49
11.2		Transmission Provider's Interconnection Facilities.....	49
11.3		Network Upgrades and Distribution Upgrades	49
11.4		Transmission Credits	49
	11.4.1	Repayment of Amounts Advanced for Network Upgrades	49
11.5		Provision of Security	51
11.6		Interconnection Customer Compensation.....	51
	11.6.1	Interconnection Customer Compensation for Actions During Emergency Condition.....	52
Article 12.		Invoice.....	52
12.1		General	52
12.2		Final Invoice.....	52
12.3		Payment	52
12.4		Disputes	53
Article 13.		Emergencies	53
13.1		Definition	53
13.2		Obligations	53
13.3		Notice	53
13.4		Immediate Action	54
13.5		Transmission Provider Authority	54
	13.5.1	General.....	54
	13.5.2	Reduction and Disconnection	55
13.6		Interconnection Customer Authority	55
13.7		Limited Liability.....	56
Article 14.		Regulatory Requirements and Governing Law.....	56
14.1		Regulatory Requirements	56
14.2		Governing Law	56

Article 15.	Notices.....	56
15.1	General	56
15.2	Billings and Payments	57
15.3	Alternative Forms of Notice.....	57
15.4	Operations and Maintenance Notice	57
Article 16.	Force Majeure.....	57
Article 17.	Default	58
17.1	Default	58
17.1.1	General.....	58
17.1.2	Right to Terminate.....	58
Article 18.	Indemnity, Consequential Damages and Insurance.....	59
18.1	Indemnity	59
18.1.1	Indemnified Person.....	59
18.1.2	Indemnifying Party.....	59
18.1.3	Indemnity Procedures	59
18.2	Consequential Damages	60
18.3	Insurance	60
Article 19.	Assignment	63
Article 20.	Severability.....	63
Article 21.	Comparability	64
Article 22.	Confidentiality	64
22.1	Confidentiality	64
22.1.1	Term	64
22.1.2	Scope	64
22.1.3	Release of Confidential Information	65
22.1.4	Rights	65
22.1.5	No Warranties	65
22.1.6	Standard of Care.....	66
22.1.7	Order of Disclosure.....	66
22.1.8	Termination of Agreement.....	66
22.1.9	Remedies	66
22.1.10	Disclosure to FERC, its Staff, or a State.....	67
Article 23.	Environmental Releases	68

Article 24.	Information Requirements	68
24.1	Information Acquisition	68
24.2	Information Submission by Transmission Provider	69
24.3	Updated Information Submission by Interconnection Customer	69
24.4	Information Supplementation	69
Article 25.	Information Access and Audit Rights.....	70
25.1	Information Access	70
25.2	Reporting of Non-Force Majeure Events	70
25.3	Audit Rights	71
25.4	Audit Rights Periods	71
25.4.1	Audit Rights Period for Construction-Related Accounts and Records	71
25.4.2	Audit Rights Period for All Other Accounts and Records... ..	71
25.5	Audit Results	72
Article 26.	Subcontractors	72
26.1	General	72
26.2	Responsibility of Principal.....	72
26.3	No Limitation by Insurance.....	72
Article 27.	Disputes	72
27.1	Submission.....	72
27.2	External Arbitration Procedures	73
27.3	Arbitration Decisions	73
27.4	Costs.....	74
Article 28.	Representations, Warranties, and Covenants.....	74
28.1	General	74
28.1.1	Good Standing.....	74
28.1.2	Authority.....	74
28.1.3	No Conflict.....	74
28.1.4	Consent and Approval.....	75
Article 29.	Joint Operating Committee	75
Article 30.	Miscellaneous	76
30.1	Binding Effect	76
30.2	Conflicts.....	76
30.3	Rules of Interpretation.....	76
30.4	Entire Agreement	77
30.5	No Third Party Beneficiaries.....	77

30.6	Waiver	77
30.7	Headings	77
30.8	Multiple Counterparts	77
30.9	Amendment	77
30.10	Modification by the Parties	78
30.11	Reservation of Rights	78
30.12	No Partnership	78

Appendix A - Interconnection Facilities, Network Upgrades, and Distribution Upgrades

Appendix B – Milestones

Appendix C – Interconnection Details

Appendix D – Security Arrangements Details

Appendix E – Commercial Operation Date

Appendix F – Addresses for Delivery of Notices and Billings

Appendix G – Requirements of Generators Relying on Newer Technologies

STANDARD LARGE GENERATOR INTERCONNECTION AGREEMENT

THIS STANDARD LARGE GENERATOR INTERCONNECTION AGREEMENT ("Agreement") is made and entered into this ____ day of __ 2004, by and between East Guymon Wind LLC, a limited liability company organized and existing under the laws of the State of Delaware ("Interconnection Customer" with a Large Generating Facility), and Southwest Power Pool, Inc., a corporation organized and existing under the laws of the State of Arkansas ("Transmission Provider") and Southwestern Public Service Company (d/b/a Xcel Energy), a corporation organized and existing under the laws of the State of New Mexico ("Transmission Owner" or "Xcel Energy"). Interconnection Customer, Transmission Provider and Transmission Owner each may be referred to as a "Party" or collectively as the "Parties."

Recitals

WHEREAS, Transmission Provider operates the Transmission System; and

WHEREAS, Interconnection Customer intends to own, lease and/or control and operate the Generating Facility identified as a Large Generating Facility in Appendix C to this Agreement; and,

WHEREAS, Interconnection Customer and Transmission Provider have agreed to enter into this Agreement for the purpose of interconnecting the Large Generating Facility with the Transmission System;

NOW, THEREFORE, in consideration of and subject to the mutual covenants contained herein, it is agreed:

When used in this Standard Large Generator Interconnection Agreement, terms with initial capitalization that are not defined in Article 1 shall have the meanings specified in the Article in which they are used or the Open Access Transmission Tariff (OATT).

Article 1. Definitions

Adverse System Impact shall mean the negative effects due to technical or operational limits on conductors or equipment being exceeded that may compromise the safety and reliability of the electric system.

Affected System shall mean an electric system other than the Transmission Provider's Transmission System that may be affected by the proposed interconnection.

Affected System Operator shall mean the entity that operates an Affected System.

Affiliate shall mean, with respect to a corporation, partnership or other entity, each such other corporation, partnership or other entity that directly or indirectly, through one or more intermediaries, controls, is controlled by, or is under common control with, such corporation, partnership or other entity.

Ancillary Services shall mean those services that are necessary to support the transmission of capacity and energy from resources to loads while maintaining reliable operation of the Transmission Provider's Transmission System in accordance with Good Utility Practice.

Applicable Laws and Regulations shall mean all duly promulgated applicable federal, state and local laws, regulations, rules, ordinances, codes, decrees, judgments, directives, or judicial or administrative orders, permits and other duly authorized actions of any Governmental Authority.

Applicable Reliability Council shall mean the reliability council applicable to the Transmission System to which the Generating Facility is directly interconnected.

Applicable Reliability Standards shall mean the requirements and guidelines of NERC, the Applicable Reliability Council, and the Control Area of the Transmission System to which the Generating Facility is directly interconnected.

Base Case shall mean the base case power flow, short circuit, and stability data bases used for the Interconnection Studies by the Transmission Provider or Interconnection Customer.

Breach shall mean the failure of a Party to perform or observe any material term or condition of the Standard Large Generator Interconnection Agreement.

Breaching Party shall mean a Party that is in Breach of the Standard Large Generator Interconnection Agreement.

Business Day shall mean Monday through Friday, excluding Federal Holidays.

Calendar Day shall mean any day including Saturday, Sunday or a Federal Holiday.

Clustering shall mean the process whereby a group of Interconnection Requests is studied together, instead of serially, for the purpose of conducting the Interconnection System Impact Study.

Commercial Operation shall mean the status of a Generating Facility that has commenced generating electricity for sale, excluding electricity generated during Trial Operation.

Commercial Operation Date of a unit shall mean the date on which the Generating Facility commences Commercial Operation as agreed to by the Parties pursuant to Appendix E to the Standard Large Generator Interconnection Agreement.

Confidential Information shall mean any confidential, proprietary or trade secret information of a plan, specification, pattern, procedure, design, device, list, concept, policy or compilation relating to the present or planned business of a Party, which is designated as confidential by the Party supplying the information, whether conveyed orally, electronically, in writing, through inspection, or otherwise.

Control Area shall mean an electrical system or systems bounded by interconnection metering and telemetry, capable of controlling generation to maintain its interchange schedule with other Control Areas and contributing to frequency regulation of the interconnection. A Control Area must be certified by the Applicable Reliability Council.

Default shall mean the failure of a Breaching Party to cure its Breach in accordance with Article 17 of the Standard Large Generator Interconnection Agreement.

Dispute Resolution shall mean the procedure for resolution of a dispute between the Parties in which they will first attempt to resolve the dispute on an informal basis.

Distribution System shall mean the Transmission Provider's facilities and equipment used to transmit electricity to ultimate usage points such as homes and industries directly from nearby generators or from interchanges with higher voltage

transmission networks which transport bulk power over longer distances. The voltage levels at which distribution systems operate differ among areas.

Distribution Upgrades shall mean the additions, modifications, and upgrades to the Transmission Provider's Distribution System at or beyond the Point of Interconnection to facilitate interconnection of the Generating Facility and render the transmission service necessary to effect Interconnection Customer's wholesale sale of electricity in interstate commerce. Distribution Upgrades do not include Interconnection Facilities.

Effective Date shall mean the date on which the Standard Large Generator Interconnection Agreement becomes effective upon execution by the Parties subject to acceptance by FERC, or if filed unexecuted, upon the date specified by FERC.

Emergency Condition shall mean a condition or situation: (1) that in the judgment of the Party making the claim is imminently likely to endanger life or property; or (2) that, in the case of a Transmission Provider, is imminently likely (as determined in a non-discriminatory manner) to cause a material adverse effect on the security of, or damage to Transmission Provider's Transmission System, Transmission Provider's Interconnection Facilities or the electric systems of others to which the Transmission Provider's Transmission System is directly connected; or (3) that, in the case of Interconnection Customer, is imminently likely (as determined in a non-discriminatory manner) to cause a material adverse effect on the security of, or damage to, the Generating Facility or Interconnection Customer's Interconnection Facilities. System restoration and black start shall be considered Emergency Conditions; provided, that Interconnection Customer is not obligated by the Standard Large Generator Interconnection Agreement to possess black start capability.

Energy Resource Interconnection Service shall mean an Interconnection Service that allows the Interconnection Customer to connect its Generating Facility to the Transmission Provider's Transmission System to be eligible to deliver the Generating Facility's electric output using the existing firm or nonfirm capacity of the Transmission Provider's Transmission System on an as available basis. Energy Resource Interconnection Service in and of itself does not convey transmission service.

Engineering & Procurement (E&P) Agreement shall mean an agreement that authorizes the Transmission Provider to begin engineering and procurement of long lead-time items necessary for the establishment of the interconnection in order to advance the implementation of the Interconnection Request.

Environmental Law shall mean Applicable Laws or Regulations relating to pollution or protection of the environment or natural resources.

Federal Power Act shall mean the Federal Power Act, as amended, 16 U.S.C. §§ 791a et seq.

FERC shall mean the Federal Energy Regulatory Commission (Commission) or its successor.

Force Majeure shall mean any act of God, labor disturbance, act of the public enemy, war, insurrection, riot, fire, storm or flood, explosion, breakage or accident to machinery or equipment, any order, regulation or restriction imposed by governmental, military or lawfully established civilian authorities, or any other caused beyond a Party's control. A Force Majeure event does not include acts of negligence or intentional wrongdoing by the Party claiming Force Majeure.

Generating Facility shall mean Interconnection Customer's device for the production of electricity identified in the Interconnection Request, but shall not include the Interconnection Customer's Interconnection Facilities.

Generating Facility Capacity shall mean the net capacity of the Generating Facility and the aggregate net capacity of the Generating Facility where it includes multiple energy production devices.

Good Utility Practice shall mean any of the practices, methods and acts engaged in or approved by a significant portion of the electric industry during the relevant time period, or any of the practices, methods and acts which, in the exercise of reasonable judgment in light of the facts known at the time the decision was made, could have been expected to accomplish the desired result at a reasonable cost consistent with good business practices, reliability, safety and expedition. Good Utility Practice is not intended to be limited to the optimum practice, method, or act to the exclusion of all others, but rather to be acceptable practices, methods, or acts generally accepted in the region.

Governmental Authority shall mean any federal, state, local or other governmental regulatory or administrative agency, court, commission, department, board, or other governmental subdivision, legislature, rulemaking board, tribunal, or other governmental authority having jurisdiction over the Parties, their respective facilities, or the respective services they provide, and exercising or entitled to exercise any administrative, executive, police, or taxing authority or power; provided, however, that such term does not include Interconnection Customer, Transmission Provider, or any Affiliate thereof.

Hazardous Substances shall mean any chemicals, materials or substances defined

as or included in the definition of "hazardous substances," "hazardous wastes," "hazardous materials," "hazardous constituents," "restricted hazardous materials," "extremely hazardous substances," "toxic substances," "radioactive substances," "contaminants," "pollutants," "toxic pollutants" or words of similar meaning and regulatory effect under any applicable Environmental Law, or any other chemical, material or substance, exposure to which is prohibited, limited or regulated by any applicable Environmental Law.

Initial Synchronization Date shall mean the date upon which the Generating Facility is initially synchronized and upon which Trial Operation begins.

In-Service Date shall mean the date upon which the Interconnection Customer reasonably expects it will be ready to begin use of the Transmission Provider's Interconnection Facilities to obtain back feed power.

Interconnection Customer shall mean any entity, including the Transmission Provider, Transmission Owner or any of the Affiliates or subsidiaries of either, that proposes to interconnect its Generating Facility with the Transmission Provider's Transmission System.

Interconnection Customer's Interconnection Facilities shall mean all facilities and equipment, as identified in Appendix A of the Standard Large Generator Interconnection Agreement, that are located between the Generating Facility and the Point of Change of Ownership, including any modification, addition, or upgrades to such facilities and equipment necessary to physically and electrically interconnect the Generating Facility to the Transmission Provider's Transmission System. Interconnection Customer's Interconnection Facilities are sole use facilities.

Interconnection Facilities shall mean the Transmission Provider's Interconnection Facilities and the Interconnection Customer's Interconnection Facilities. Collectively, Interconnection Facilities include all facilities and equipment between the Generating Facility and the Point of Interconnection, including any modification, additions or upgrades that are necessary to physically and electrically interconnect the Generating Facility to the Transmission Provider's Transmission System. Interconnection Facilities are sole use facilities and shall not include Distribution Upgrades, Stand Alone Network Upgrades or Network Upgrades.

Interconnection Facilities Study shall mean a study conducted by the Transmission Provider or a third party consultant for the Interconnection Customer to determine a list of facilities (including Transmission Provider's Interconnection Facilities and Network Upgrades as identified in the Interconnection System Impact Study), the

cost of those facilities, and the time required to interconnect the Generating Facility with the Transmission Provider's Transmission System. The scope of the study is defined in Section 8 of the Standard Large Generator Interconnection Procedures.

Interconnection Facilities Study Agreement shall mean the form of agreement contained in Appendix 4 of the Standard Large Generator Interconnection Procedures for conducting the Interconnection Facilities Study.

Interconnection Feasibility Study shall mean a preliminary evaluation of the system impact and cost of interconnecting the Generating Facility to the Transmission Provider's Transmission System, the scope of which is described in Section 6 of the Standard Large Generator Interconnection Procedures.

Interconnection Feasibility Study Agreement shall mean the form of agreement contained in Appendix 2 of the Standard Large Generator Interconnection Procedures for conducting the Interconnection Feasibility Study.

Interconnection Request shall mean an Interconnection Customer's request, in the form of Appendix 1 to the Standard Large Generator Interconnection Procedures, in accordance with the Tariff, to interconnect a new Generating Facility, or to increase the capacity of, or make a Material Modification to the operating characteristics of, an existing Generating Facility that is interconnected with the Transmission Provider's Transmission System.

Interconnection Service shall mean the service provided by the Transmission Provider associated with interconnecting the Interconnection Customer's Generating Facility to the Transmission Provider's Transmission System and enabling it to receive electric energy and capacity from the Generating Facility at the Point of Interconnection, pursuant to the terms of the Standard Large Generator Interconnection Agreement and, if applicable, the Transmission Provider's Tariff.

Interconnection Study shall mean any of the following studies: the Interconnection Feasibility Study, the Interconnection System Impact Study, and the Interconnection Facilities Study described in the Standard Large Generator Interconnection Procedures.

Interconnection System Impact Study shall mean an engineering study that evaluates the impact of the proposed interconnection on the safety and reliability of Transmission Provider's Transmission System and, if applicable, an Affected System. The study shall identify and detail the system impacts that would result if the Generating Facility were interconnected without project modifications or system modifications,

focusing on the Adverse System Impacts identified in the Interconnection Feasibility Study, or to study potential impacts, including but not limited to those identified in the Scoping Meeting as described in the Standard Large Generator Interconnection Procedures.

Interconnection System Impact Study Agreement shall mean the form of agreement contained in Appendix 3 of the Standard Large Generator Interconnection Procedures for conducting the Interconnection System Impact Study.

IRS shall mean the Internal Revenue Service.

Joint Operating Committee shall be a group made up of representatives from Interconnection Customers and the Transmission Provider to coordinate operating and technical considerations of Interconnection Service.

Large Generating Facility shall mean a Generating Facility having a Generating Facility Capacity of more than 20 MW.

Loss shall mean any and all losses relating to injury to or death of any person or damage to property, demand, suits, recoveries, costs and expenses, court costs, attorney fees, and all other obligations by or to third parties, arising out of or resulting from the other Party's performance, or non-performance of its obligations under the Standard Large Generator Interconnection Agreement on behalf of the indemnifying Party, except in cases of gross negligence or intentional wrongdoing by the indemnifying Party.

Material Modification shall mean those modifications that have a material impact on the cost or timing of any Interconnection Request with a later queue priority date.

Metering Equipment shall mean all metering equipment installed or to be installed at the Generating Facility pursuant to the Standard Large Generator Interconnection Agreement at the metering points, including but not limited to instrument transformers, MWh-meters, data acquisition equipment, transducers, remote terminal unit, communications equipment, phone lines, and fiber optics.

NERC shall mean the North American Electric Reliability Council or its successor organization.

Network Resource shall mean any designated generating resource owned, purchased, or leased by a Network Customer under the Network Integration Transmission Service Tariff. Network Resources do not include any resource, or any portion thereof, that is committed for sale to third parties or otherwise cannot be called upon to meet the

Network Customer's Network Load on a non-interruptible basis.

Network Resource Interconnection Service shall mean an Interconnection Service that allows the Interconnection Customer to integrate its Large Generating Facility with the Transmission Provider's Transmission System (1) in a manner comparable to that in which the Transmission Provider integrates its generating facilities to serve native load customers; or (2) in an RTO or ISO with market based congestion management, in the same manner as all other Network Resources. Network Resource Interconnection Service in and of itself does not convey transmission service.

Network Upgrades shall mean the additions, modifications, and upgrades to the Transmission Provider's Transmission System required at or beyond the point at which the Interconnection Facilities connect to the Transmission Provider's Transmission System to accommodate the interconnection of the Large Generating Facility to the Transmission Provider's Transmission System.

Notice of Dispute shall mean a written notice of a dispute or claim that arises out of or in connection with the Standard Large Generator Interconnection Agreement or its performance.

Optional Interconnection Study shall mean a sensitivity analysis based on assumptions specified by the Interconnection Customer in the Optional Interconnection Study Agreement.

Optional Interconnection Study Agreement shall mean the form of agreement contained in Appendix 5 of the Standard Large Generator Interconnection Procedures for conducting the Optional Interconnection Study.

Party or Parties shall mean Transmission Provider, Transmission Owner, Interconnection Customer or any combination of the above.

Point of Change of Ownership shall mean the point, as set forth in Appendix A to the Standard Large Generator Interconnection Agreement, where the Interconnection Customer's Interconnection Facilities connect to the Transmission Provider's Interconnection Facilities.

Point of Interconnection shall mean the point, as set forth in Appendix A to the Standard Large Generator Interconnection Agreement, where the Interconnection Facilities connect to the Transmission Provider's Transmission System.

Queue Position shall mean the order of a valid Interconnection Request, relative

to all other pending valid Interconnection Requests, that is established based upon the date and time of receipt of the valid Interconnection Request by the Transmission Provider.

Reasonable Efforts shall mean, with respect to an action required to be attempted or taken by a Party under the Standard Large Generator Interconnection Agreement, efforts that are timely and consistent with Good Utility Practice and are otherwise substantially equivalent to those a Party would use to protect its own interests.

Scoping Meeting shall mean the meeting between representatives of the Interconnection Customer and Transmission Provider conducted for the purpose of discussing alternative interconnection options, to exchange information including any transmission data and earlier study evaluations that would be reasonably expected to impact such interconnection options, to analyze such information, and to determine the potential feasible Points of Interconnection.

Site Control shall mean documentation reasonably demonstrating: (1) ownership of, a leasehold interest in, or a right to develop a site for the purpose of constructing the Generating Facility; (2) an option to purchase or acquire a leasehold site for such purpose; or (3) an exclusivity or other business relationship between Interconnection Customer and the entity having the right to sell, lease or grant Interconnection Customer the right to possess or occupy a site for such purpose.

Small Generating Facility shall mean a Generating Facility that has a Generating Facility Capacity of no more than 20 MW.

Stand Alone Network Upgrades shall mean Network Upgrades that an Interconnection Customer may construct without affecting day-to-day operations of the Transmission System during their construction. Both the Transmission Provider and the Interconnection Customer must agree as to what constitutes Stand Alone Network Upgrades and identify them in Appendix A to the Standard Large Generator Interconnection Agreement.

Standard Large Generator Interconnection Agreement (LGIA) shall mean the form of interconnection agreement applicable to an Interconnection Request pertaining to a Large Generating Facility that is included in the Transmission Provider's Tariff.

Standard Large Generator Interconnection Procedures (LGIP) shall mean the interconnection procedures applicable to an Interconnection Request pertaining to a Large Generating Facility that are included in the Transmission Provider's Tariff.

System Protection Facilities shall mean the equipment, including necessary protection signal communications equipment, required to protect (1) the Transmission Provider's Transmission System from faults or other electrical disturbances occurring at the Generating Facility and (2) the Generating Facility from faults or other electrical system disturbances occurring on the Transmission Provider's Transmission System or on other delivery systems or other generating systems to which the Transmission Provider's Transmission System is directly connected.

Tariff shall mean the Transmission Provider's Tariff through which open access transmission service and Interconnection Service are offered, as filed with FERC, and as amended or supplemented from time to time, or any successor tariff.

Transmission Owner shall mean an entity that owns, leases or otherwise possesses an interest in the portion of the Transmission System at the Point of Interconnection and may be a Party to the Standard Large Generator Interconnection Agreement to the extent necessary.

Transmission Provider shall mean the public utility (or its designated agent) that owns, controls, or operates transmission or distribution facilities used for the transmission of electricity in interstate commerce and provides transmission service under the Tariff. The term Transmission Provider should be read to include the Transmission Owner when the Transmission Owner is separate from the Transmission Provider.

Transmission Provider's Interconnection Facilities shall mean all facilities and equipment owned, controlled or operated by the Transmission Provider from the Point of Change of Ownership to the Point of Interconnection as identified in Appendix A to the Standard Large Generator Interconnection Agreement, including any modifications, additions or upgrades to such facilities and equipment. Transmission Provider's Interconnection Facilities are sole use facilities and shall not include Distribution Upgrades, Stand Alone Network Upgrades or Network Upgrades.

Transmission System shall mean the facilities owned, controlled or operated by the Transmission Provider or Transmission Owner that are used to provide transmission service under the Tariff.

Trial Operation shall mean the period during which Interconnection Customer is engaged in on-site test operations and commissioning of the Generating Facility prior to Commercial Operation.

Article 2. Effective Date, Term, and Termination

2.1 Effective Date. This LGIA shall become effective upon execution by the Parties subject to acceptance by FERC (if applicable), or if filed unexecuted, upon the date specified by FERC. Transmission Provider shall promptly file this LGIA with FERC upon execution in accordance with Article 3.1, if required.

2.2 Term of Agreement. Subject to the provisions of Article 2.3, this LGIA shall remain in effect for a period of Twenty (20) years from the Effective Date and shall be automatically renewed for each successive one-year period thereafter.

2.3 Termination Procedures.

2.3.1 Written Notice. This LGIA may be terminated by Interconnection Customer after giving Transmission Provider ninety (90) Calendar Days advance written notice, or by Transmission Provider notifying FERC after the Generating Facility permanently ceases Commercial Operation.

2.3.2 Default. Either Party may terminate this LGIA in accordance with Article 17.

2.3.3 Notwithstanding Articles 2.3.1 and 2.3.2, no termination shall become effective until the Parties have complied with all Applicable Laws and Regulations applicable to such termination, including the filing with FERC of a notice of termination of this LGIA, which notice has been accepted for filing by FERC.

2.4 Termination Costs. If a Party elects to terminate this Agreement pursuant to Article 2.3 above, each Party shall pay all costs incurred (including any cancellation costs relating to orders or contracts for Interconnection Facilities and equipment) or charges assessed by the other Party, as of the date of the other Party's receipt of such notice of termination, that are the responsibility of the Terminating Party under this LGIA. In the event of termination by a Party, the Parties shall use commercially Reasonable Efforts to mitigate the costs, damages and charges arising as a consequence of termination. Upon termination of this LGIA, unless otherwise ordered or approved by FERC:

2.4.1 With respect to any portion of Transmission Provider's Interconnection Facilities that have not yet been constructed or installed, Transmission Provider shall to the extent possible and with Interconnection Customer's authorization cancel any pending orders of, or return, any materials or equipment for, or contracts for construction of, such facilities; provided that

in the event Interconnection Customer elects not to authorize such cancellation, Interconnection Customer shall assume all payment obligations with respect to such materials, equipment, and contracts, and Transmission Provider shall deliver such material and equipment, and, if necessary, assign such contracts, to Interconnection Customer as soon as practicable, at Interconnection Customer's expense. To the extent that Interconnection Customer has already paid Transmission Provider for any or all such costs of materials or equipment not taken by Interconnection Customer, Transmission Provider shall promptly refund such amounts to Interconnection Customer, less any costs, including penalties incurred by Transmission Provider to cancel any pending orders of or return such materials, equipment, or contracts.

If an Interconnection Customer terminates this LGIA, it shall be responsible for all costs incurred in association with that Interconnection Customer's interconnection, including any cancellation costs relating to orders or contracts for Interconnection Facilities and equipment, and other expenses including any Network Upgrades for which Transmission Provider has incurred expenses and has not been reimbursed by Interconnection Customer.

2.4.2 Transmission Provider may, at its option, retain any portion of such materials, equipment, or facilities that Interconnection Customer chooses not to accept delivery of, in which case Transmission Provider shall be responsible for all costs associated with procuring such materials, equipment, or facilities.

2.4.3 With respect to any portion of the Interconnection Facilities, and any other facilities already installed or constructed pursuant to the terms of this LGIA, Interconnection Customer shall be responsible for all costs associated with the removal, relocation or other disposition or retirement of such materials, equipment, or facilities.

2.5 Disconnection. Upon termination of this LGIA, the Parties will take all appropriate steps to disconnect the Large Generating Facility from the Transmission System. All costs required to effectuate such disconnection shall be borne by the terminating Party, unless such termination resulted from the non-terminating Party's Default of this LGIA or such non-terminating Party otherwise is responsible for these costs under this LGIA.

2.6 Survival. This LGIA shall continue in effect after termination to the extent

necessary to provide for final billings and payments and for costs incurred hereunder, including billings and payments pursuant to this LGIA; to permit the determination and enforcement of liability and indemnification obligations arising from acts or events that occurred while this LGIA was in effect; and to permit each Party to have access to the lands of the other Party pursuant to this LGIA or other applicable agreements, to disconnect, remove or salvage its own facilities and equipment.

Article 3. Regulatory Filings

3.1 Filing. Transmission Provider shall file this LGIA (and any amendment hereto) with the appropriate Governmental Authority, if required. Interconnection Customer may request that any information so provided be subject to the confidentiality provisions of Article 22. If Interconnection Customer has executed this LGIA, or any amendment thereto, Interconnection Customer shall reasonably cooperate with Transmission Provider with respect to such filing and to provide any information reasonably requested by Transmission Provider needed to comply with applicable regulatory requirements.

Article 4. Scope of Service

4.1 Interconnection Product Options. Interconnection Customer has selected the following (checked) type of Interconnection Service:

4.1.1 Energy Resource Interconnection Service.

4.1.1.1 The Product. Energy Resource Interconnection Service allows Interconnection Customer to connect the Large Generating Facility to the Transmission System and be eligible to deliver the Large Generating Facility's output using the existing firm or non-firm capacity of the Transmission System on an "as available" basis. To the extent Interconnection Customer wants to receive Energy Resource Interconnection Service, Transmission Provider shall construct facilities identified in Attachment A.

4.1.1.2 Transmission Delivery Service Implications. Under Energy Resource Interconnection Service, Interconnection Customer will be eligible to inject power from the Large Generating

Facility into and deliver power across the interconnecting Transmission Provider's Transmission System on an "as available" basis up to the amount of MWs identified in the applicable stability and steady state studies to the extent the upgrades initially required to qualify for Energy Resource Interconnection Service have been constructed. Where eligible to do so (e.g., PJM, ISO-NE, NYISO), Interconnection Customer may place a bid to sell into the market up to the maximum identified Large Generating Facility output, subject to any conditions specified in the interconnection service approval, and the Large Generating Facility will be dispatched to the extent Interconnection Customer's bid clears. In all other instances, no transmission delivery service from the Large Generating Facility is assured, but Interconnection Customer may obtain Point-to-Point Transmission Service, Network Integration Transmission Service, or be used for secondary network transmission service, pursuant to Transmission Provider's Tariff, up to the maximum output identified in the stability and steady state studies. In those instances, in order for Interconnection Customer to obtain the right to deliver or inject energy beyond the Large Generating Facility Point of Interconnection or to improve its ability to do so, transmission delivery service must be obtained pursuant to the provisions of Transmission Provider's Tariff. The Interconnection Customer's ability to inject its Large Generating Facility output beyond the Point of Interconnection, therefore, will depend on the existing capacity of Transmission Provider's Transmission System at such time as a transmission service request is made that would accommodate such delivery. The provision of firm Point-to-Point Transmission Service or Network Integration Transmission Service may require the construction of additional Network Upgrades.

4.1.2 Network Resource Interconnection Service.

4.1.2.1 The Product. Transmission Provider must conduct the necessary studies and construct the Network Upgrades needed to integrate the Large Generating Facility (1) in a manner comparable to that in which Transmission Provider integrates its generating facilities to serve native load customers; or (2)

in an ISO or RTO with market based congestion management, in the same manner as all Network Resources. To the extent Interconnection Customer wants to receive Network Resource Interconnection Service, Transmission Provider shall construct the facilities identified in Attachment A to this LGIA.

4.1.2.2 Transmission Delivery Service Implications. Network Resource Interconnection Service allows Interconnection Customer's Large Generating Facility to be designated by any Network Customer under the Tariff on Transmission Provider's Transmission System as a Network Resource, up to the Large Generating Facility's full output, on the same basis as existing Network Resources interconnected to Transmission Provider's Transmission System, and to be studied as a Network Resource on the assumption that such a designation will occur. Although Network Resource Interconnection Service does not convey a reservation of transmission service, any Network Customer under the Tariff can utilize its network service under the Tariff to obtain delivery of energy from the interconnected Interconnection Customer's Large Generating Facility in the same manner as it accesses other Network Resources. A Large Generating Facility receiving Network Resource Interconnection Service may also be used to provide Ancillary Services after technical studies and/or periodic analyses are performed with respect to the Large Generating Facility's ability to provide any applicable Ancillary Services, provided that such studies and analyses have been or would be required in connection with the provision of such Ancillary Services by any existing Network Resource. However, if an Interconnection Customer's Large Generating Facility has not been designated as a Network Resource by any load, it cannot be required to provide Ancillary Services except to the extent such requirements extend to all generating facilities that are similarly situated. The provision of Network Integration Transmission Service or firm Point-to-Point Transmission Service may require additional studies and the construction of additional upgrades. Because such studies and upgrades would be associated with a request for delivery service under the Tariff, cost responsibility for the studies and upgrades

would be in accordance with FERC's policy for pricing transmission delivery services.

Network Resource Interconnection Service does not necessarily provide Interconnection Customer with the capability to physically deliver the output of its Large Generating Facility to any particular load on Transmission Provider's Transmission System without incurring congestion costs. In the event of transmission constraints on Transmission Provider's Transmission System, Interconnection Customer's Large Generating Facility shall be subject to the applicable congestion management procedures in Transmission Provider's Transmission System in the same manner as all other Network Resources.

There is no requirement either at the time of study or interconnection, or at any point in the future, that Interconnection Customer's Large Generating Facility be designated as a Network Resource by a Network Service Customer under the Tariff or that Interconnection Customer identify a specific buyer (or sink). To the extent a Network Customer does designate the Large Generating Facility as a Network Resource, it must do so pursuant to Transmission Provider's Tariff.

Once an Interconnection Customer satisfies the requirements for obtaining Network Resource Interconnection Service, any future transmission service request for delivery from the Large Generating Facility within Transmission Provider's Transmission System of any amount of capacity and/or energy, up to the amount initially studied, will not require that any additional studies be performed or that any further upgrades associated with such Large Generating Facility be undertaken, regardless of whether or not such Large Generating Facility is ever designated by a Network Customer as a Network Resource and regardless of changes in ownership of the Large Generating Facility. However, the reduction or elimination of congestion or redispatch costs may require additional studies and the construction of additional upgrades.

To the extent Interconnection Customer enters into an arrangement for long term transmission service for deliveries from the Large Generating Facility outside Transmission Provider's Transmission System, such request may require additional studies and upgrades in order for Transmission Provider to grant such request.

- 4.2 Provision of Service.** Transmission Provider shall provide Interconnection Service for the Large Generating Facility at the Point of Interconnection.
- 4.3 Performance Standards.** Each Party shall perform all of its obligations under this LGIA in accordance with Applicable Laws and Regulations, Applicable Reliability Standards, and Good Utility Practice, and to the extent a Party is required or prevented or limited in taking any action by such regulations and standards, such Party shall not be deemed to be in Breach of this LGIA for its compliance therewith. If such Party is a Transmission Provider or Transmission Owner, then that Party shall amend the LGIA and submit the amendment to FERC for approval.
- 4.4 No Transmission Delivery Service.** The execution of this LGIA does not constitute a request for, nor the provision of, any transmission delivery service under Transmission Provider's Tariff, and does not convey any right to deliver electricity to any specific customer or Point of Delivery.
- 4.5 Interconnection Customer Provided Services.** The services provided by Interconnection Customer under this LGIA are set forth in Article 9.6 and Article 13.5.1. Interconnection Customer shall be paid for such services in accordance with Article 11.6.

Article 5. Interconnection Facilities Engineering, Procurement, and Construction

5.1 Options. Unless otherwise mutually agreed to between the Parties, Interconnection Customer shall select the In-Service Date, Initial Synchronization Date, and Commercial Operation Date; and either Standard Option or Alternate Option set forth below for completion of Transmission Provider's Interconnection Facilities and Network Upgrades as set forth in Appendix A, Interconnection Facilities and Network Upgrades, and such dates and selected option shall be set forth in Appendix B, Milestones.

5.1.1 Standard Option. Transmission Provider shall design, procure, and construct Transmission Provider's Interconnection Facilities and Network

Upgrades, using Reasonable Efforts to complete Transmission Provider's Interconnection Facilities and Network Upgrades by the dates set forth in Appendix B, Milestones. Transmission Provider shall not be required to undertake any action which is inconsistent with its standard safety practices, its material and equipment specifications, its design criteria and construction procedures, its labor agreements, and Applicable Laws and Regulations. In the event Transmission Provider reasonably expects that it will not be able to complete Transmission Provider's Interconnection Facilities and Network Upgrades by the specified dates, Transmission Provider shall promptly provide written notice to Interconnection Customer and shall undertake Reasonable Efforts to meet the earliest dates thereafter.

- 5.1.2 Alternate Option.** If the dates designated by Interconnection Customer are acceptable to Transmission Provider, Transmission Provider shall so notify Interconnection Customer within thirty (30) Calendar Days, and shall assume responsibility for the design, procurement and construction of Transmission Provider's Interconnection Facilities by the designated dates.

If Transmission Provider subsequently fails to complete Transmission Provider's Interconnection Facilities by the In-Service Date, to the extent necessary to provide back feed power; or fails to complete Network Upgrades by the Initial Synchronization Date to the extent necessary to allow for Trial Operation at full power output, unless other arrangements are made by the Parties for such Trial Operation; or fails to complete the Network Upgrades by the Commercial Operation Date, as such dates are reflected in Appendix B, Milestones; Transmission Provider shall pay Interconnection Customer liquidated damages in accordance with Article 5.3, Liquidated Damages, provided, however, the dates designated by Interconnection Customer shall be extended day for day for each day that the applicable RTO or ISO refuses to grant clearances to install equipment.

- 5.1.3 Option to Build.** If the dates designated by Interconnection Customer are not acceptable to Transmission Provider, Transmission Provider shall so notify Interconnection Customer within thirty (30) Calendar Days, and unless the Parties agree otherwise, Interconnection Customer shall have the option to assume responsibility for the design, procurement and construction of Transmission Provider's Interconnection Facilities and Stand Alone Network Upgrades on the dates specified in Article 5.1.2. Transmission Provider and Interconnection Customer must agree as to what constitutes Stand Alone Network Upgrades and identify such Stand Alone Network Upgrades in Appendix A. Except for Stand Alone Network

Upgrades, Interconnection Customer shall have no right to construct Network Upgrades under this option.

5.1.4 Negotiated Option. If Interconnection Customer elects not to exercise its option under Article 5.1.3, Option to Build, Interconnection Customer shall so notify Transmission Provider within thirty (30) Calendar Days, and the Parties shall in good faith attempt to negotiate terms and conditions (including revision of the specified dates and liquidated damages, the provision of incentives or the procurement and construction of a portion of Transmission Provider's Interconnection Facilities and Stand Alone Network Upgrades by Interconnection Customer) pursuant to which Transmission Provider is responsible for the design, procurement and construction of Transmission Provider's Interconnection Facilities and Network Upgrades. If the Parties are unable to reach agreement on such terms and conditions, Transmission Provider shall assume responsibility for the design, procurement and construction of Transmission Provider's Interconnection Facilities and Network Upgrades pursuant to 5.1.1, Standard Option.

5.2 General Conditions Applicable to Option to Build. If Interconnection Customer assumes responsibility for the design, procurement and construction of Transmission Provider's Interconnection Facilities and Stand Alone Network Upgrades,

(1) Interconnection Customer shall engineer, procure equipment, and construct Transmission Provider's Interconnection Facilities and Stand Alone Network Upgrades (or portions thereof) using Good Utility Practice and using standards and specifications provided in advance by Transmission Provider;

(2) Interconnection Customer's engineering, procurement and construction of Transmission Provider's Interconnection Facilities and Stand Alone Network Upgrades shall comply with all requirements of law to which Transmission Provider would be subject in the engineering, procurement or construction of Transmission Provider's Interconnection Facilities and Stand Alone Network Upgrades;

(3) Transmission Provider shall review and approve the engineering design, equipment acceptance tests, and the construction of Transmission Provider's Interconnection Facilities and Stand Alone Network Upgrades;

(4) prior to commencement of construction, Interconnection Customer shall provide to Transmission Provider a schedule for construction of Transmission Provider's Interconnection Facilities and Stand Alone Network Upgrades, and shall promptly respond to requests for information from Transmission Provider;

(5) at any time during construction, Transmission Provider shall have the right to gain unrestricted access to Transmission Provider's Interconnection Facilities and Stand Alone Network Upgrades and to conduct inspections of the same;

(6) at any time during construction, should any phase of the engineering, equipment procurement, or construction of Transmission Provider's Interconnection Facilities and Stand Alone Network Upgrades not meet the standards and specifications provided by Transmission Provider, Interconnection Customer shall be obligated to remedy deficiencies in that portion of Transmission Provider's Interconnection Facilities and Stand Alone Network Upgrades;

(7) Interconnection Customer shall indemnify Transmission Provider for claims arising from Interconnection Customer's construction of Transmission Provider's Interconnection Facilities and Stand Alone Network Upgrades under the terms and procedures applicable to Article 18.1 Indemnity;

(8) Interconnection Customer shall transfer control of Transmission Provider's Interconnection Facilities and Stand Alone Network Upgrades to Transmission Provider;

(9) Unless Parties otherwise agree, Interconnection Customer shall transfer ownership of Transmission Provider's Interconnection Facilities and Stand-Alone Network Upgrades to Transmission Provider;

(10) Transmission Provider shall approve and accept for operation and maintenance Transmission Provider's Interconnection Facilities and Stand Alone Network Upgrades to the extent engineered, procured, and constructed in accordance with this Article 5.2; and

(11) Interconnection Customer shall deliver to Transmission Provider "as-built" drawings, information, and any other documents that are reasonably required by Transmission Provider to assure that the Interconnection

Facilities and Stand-Alone Network Upgrades are built to the standards and specifications required by Transmission Provider.

5.3 Liquidated Damages. The actual damages to Interconnection Customer, in the event Transmission Provider's Interconnection Facilities or Network Upgrades are not completed by the dates designated by Interconnection Customer and accepted by Transmission Provider pursuant to subparagraphs 5.1.2 or 5.1.4, above, may include Interconnection Customer's fixed operation and maintenance costs and lost opportunity costs. Such actual damages are uncertain and impossible to determine at this time. Because of such uncertainty, any liquidated damages paid by Transmission Provider to Interconnection Customer in the event that Transmission Provider does not complete any portion of Transmission Provider's Interconnection Facilities or Network Upgrades by the applicable dates, shall be an amount equal to ½ of 1 percent per day of the actual cost of Transmission Provider's Interconnection Facilities and Network Upgrades, in the aggregate, for which Transmission Provider has assumed responsibility to design, procure and construct.

However, in no event shall the total liquidated damages exceed 20 percent of the actual cost of Transmission Provider's Interconnection Facilities and Network Upgrades for which Transmission Provider has assumed responsibility to design, procure, and construct. The foregoing payments will be made by Transmission Provider to Interconnection Customer as just compensation for the damages caused to Interconnection Customer, which actual damages are uncertain and impossible to determine at this time, and as reasonable liquidated damages, but not as a penalty or a method to secure performance of this LGIA. Liquidated damages, when the Parties agree to them, are the exclusive remedy for the Transmission Provider's failure to meet its schedule.

No liquidated damages shall be paid to Interconnection Customer if: (1) Interconnection Customer is not ready to commence use of Transmission Provider's Interconnection Facilities or Network Upgrades to take the delivery of power for the Large Generating Facility's Trial Operation or to export power from the Large Generating Facility on the specified dates, unless Interconnection Customer would have been able to commence use of Transmission Provider's Interconnection Facilities or Network Upgrades to take the delivery of power for Large Generating Facility's Trial Operation or to export power from the Large Generating Facility, but for Transmission Provider's delay; (2) Transmission Provider's failure to meet the specified dates is the result of the action or inaction of Interconnection Customer or any other Interconnection Customer who has entered into an LGIA with Transmission Provider or any cause beyond Transmission Provider's reasonable control or reasonable ability to cure; (3) the

interconnection Customer has assumed responsibility for the design, procurement and construction of Transmission Provider's Interconnection Facilities and Stand Alone Network Upgrades; or (4) the Parties have otherwise agreed.

5.4 Power System Stabilizers. The Interconnection Customer shall procure, install, maintain and operate Power System Stabilizers in accordance with the guidelines and procedures established by the Applicable Reliability Council. Transmission Provider reserves the right to reasonably establish minimum acceptable settings for any installed Power System Stabilizers, subject to the design and operating limitations of the Large Generating Facility. If the Large Generating Facility's Power System Stabilizers are removed from service or not capable of automatic operation, Interconnection Customer shall immediately notify Transmission Provider's system operator, or its designated representative. The requirements of this paragraph shall not apply to wind generators.

5.5 Equipment Procurement. If responsibility for construction of Transmission Provider's Interconnection Facilities or Network Upgrades is to be borne by Transmission Provider, then Transmission Provider shall commence design of Transmission Provider's Interconnection Facilities or Network Upgrades and procure necessary equipment as soon as practicable after all of the following conditions are satisfied, unless the Parties otherwise agree in writing:

5.5.1 Transmission Provider has completed the Facilities Study pursuant to the Facilities Study Agreement;

5.5.2 Transmission Provider has received written authorization to proceed with design and procurement from Interconnection Customer by the date specified in Appendix B, Milestones; and

5.5.3 Interconnection Customer has provided security to Transmission Provider in accordance with Article 11.5 by the dates specified in Appendix B, Milestones.

5.6 Construction Commencement. Transmission Provider shall commence construction of Transmission Provider's Interconnection Facilities and Network Upgrades for which it is responsible as soon as practicable after the following additional conditions are satisfied:

5.6.1 Approval of the appropriate Governmental Authority has been obtained for any facilities requiring regulatory approval;

- 5.6.2** Necessary real property rights and rights-of-way have been obtained, to the extent required for the construction of a discrete aspect of Transmission Provider's Interconnection Facilities and Network Upgrades;
- 5.6.3** Transmission Provider has received written authorization to proceed with construction from Interconnection Customer by the date specified in Appendix B, Milestones; and
- 5.6.4** Interconnection Customer has provided security to Transmission Provider in accordance with Article 11.5 by the dates specified in Appendix B, Milestones.
- 5.7 Work Progress.** The Parties will keep each other advised periodically as to the progress of their respective design, procurement and construction efforts. Either Party may, at any time, request a progress report from the other Party. If, at any time, Interconnection Customer determines that the completion of Transmission Provider's Interconnection Facilities will not be required until after the specified In-Service Date, Interconnection Customer will provide written notice to Transmission Provider of such later date upon which the completion of Transmission Provider's Interconnection Facilities will be required.
- 5.8 Information Exchange.** As soon as reasonably practicable after the Effective Date, the Parties shall exchange information regarding the design and compatibility of the Parties' Interconnection Facilities and compatibility of the Interconnection Facilities with Transmission Provider's Transmission System, and shall work diligently and in good faith to make any necessary design changes.
- 5.9 Limited Operation.** If any of Transmission Provider's Interconnection Facilities or Network Upgrades are not reasonably expected to be completed prior to the Commercial Operation Date of the Large Generating Facility, Transmission Provider shall, upon the request and at the expense of Interconnection Customer, perform operating studies on a timely basis to determine the extent to which the Large Generating Facility and Interconnection Customer's Interconnection Facilities may operate prior to the completion of Transmission Provider's Interconnection Facilities or Network Upgrades consistent with Applicable Laws and Regulations, Applicable Reliability Standards, Good Utility Practice, and this LGIA. Transmission Provider shall permit Interconnection Customer to operate the Large Generating Facility and Interconnection Customer's Interconnection Facilities in accordance with the results of such studies.
- 5.10 Interconnection Customer's Interconnection Facilities ('ICIF').**

Interconnection Customer shall, at its expense, design, procure, construct, own and install the ICIF, as set forth in Appendix A, Interconnection Facilities, Network Upgrades and Distribution Upgrades.

5.10.1 Interconnection Customer's Interconnection Facility

Specifications. Interconnection Customer shall submit initial specifications for the ICIF, including System Protection Facilities, to Transmission Provider at least one hundred eighty (180) Calendar Days prior to the Initial Synchronization Date; and final specifications for review and comment at least ninety (90) Calendar Days prior to the Initial Synchronization Date. Transmission Provider shall review such specifications to ensure that the ICIF are compatible with the technical specifications, operational control, and safety requirements of Transmission Provider and comment on such specifications within thirty (30) Calendar Days of Interconnection Customer's submission. All specifications provided hereunder shall be deemed confidential.

5.10.2 Transmission Provider's Review. Transmission Provider's review of Interconnection Customer's final specifications shall not be construed as confirming, endorsing, or providing a warranty as to the design, fitness, safety, durability or reliability of the Large Generating Facility, or the ICIF. Interconnection Customer shall make such changes to the ICIF as may reasonably be required by Transmission Provider, in accordance with Good Utility Practice, to ensure that the ICIF are compatible with the technical specifications, operational control, and safety requirements of Transmission Provider.

5.10.3 ICIF Construction. The ICIF shall be designed and constructed in accordance with Good Utility Practice. Within one hundred twenty (120) Calendar Days after the Commercial Operation Date, unless the Parties agree on another mutually acceptable deadline, Interconnection Customer shall deliver to Transmission Provider "as-built" drawings, information and documents for the ICIF, such as: a one-line diagram, a site plan showing the Large Generating Facility and the ICIF, plan and elevation drawings showing the layout of the ICIF, a relay functional diagram, relaying AC and DC schematic wiring diagrams and relay settings for all facilities associated with Interconnection Customer's step-up transformers, the facilities connecting the Large Generating Facility to the step-up transformers

and the ICIF, and the impedances (determined by factory tests) for the associated step-up transformers and the Large Generating Facility. The Interconnection Customer shall provide Transmission Provider specifications for the excitation system, automatic voltage regulator, Large Generating Facility control and protection settings, transformer tap settings, and communications, if applicable.

5.11 Transmission Provider's Interconnection Facilities Construction.

Transmission Provider's Interconnection Facilities shall be designed and constructed in accordance with Good Utility Practice. Upon request, within one hundred twenty (120) Calendar Days after the Commercial Operation Date, unless the Parties agree on another mutually acceptable deadline, Transmission Provider shall deliver to Interconnection Customer the following "as-built" drawings, information and documents for Transmission Provider's Interconnection Facilities [include appropriate drawings and relay diagrams].

Transmission Provider will obtain control of Transmission Provider's Interconnection Facilities and Stand Alone Network Upgrades upon completion of such facilities.

5.12 Access Rights. Upon reasonable notice and supervision by a Party, and subject to any required or necessary regulatory approvals, a Party ("Granting Party") shall furnish at no cost to the other Party ("Access Party") any rights of use, licenses, rights of way and easements with respect to lands owned or controlled by the Granting Party, its agents (if allowed under the applicable agency agreement), or any Affiliate, that are necessary to enable the Access Party to obtain ingress and egress to construct, operate, maintain, repair, test (or witness testing), inspect, replace or remove facilities and equipment to: (i) interconnect the Large Generating Facility with the Transmission System; (ii) operate and maintain the Large Generating Facility, the Interconnection Facilities and the Transmission System; and (iii) disconnect or remove the Access Party's facilities and equipment upon termination of this LGIA. In exercising such licenses, rights of way and easements, the Access Party shall not unreasonably disrupt or interfere with normal operation of the Granting Party's business and shall adhere to the safety rules and procedures established in advance, as may be changed from time to time, by the Granting Party and provided to the Access Party.

5.13 Lands of Other Property Owners. If any part of Transmission Provider or Transmission Owner's Interconnection Facilities and/or Network Upgrades is to be installed on property owned by persons other than Interconnection Customer or

Transmission Provider or Transmission Owner, Transmission Provider or Transmission Owner shall at Interconnection Customer's expense use efforts, similar in nature and extent to those that it typically undertakes on its own behalf or on behalf of its Affiliates, including use of its eminent domain authority, and to the extent consistent with state law, to procure from such persons any rights of use, licenses, rights of way and easements that are necessary to construct, operate, maintain, test, inspect, replace or remove Transmission Provider or Transmission Owner's Interconnection Facilities and/or Network Upgrades upon such property.

- 5.14 Permits.** The LGIA shall specify the allocation of the responsibilities of Transmission Provider or Transmission Owner and Interconnection Customer to obtain all permits, licenses and authorizations that are necessary to accomplish the interconnection in compliance with Applicable Laws and Regulations. Transmission Provider or Transmission Owner and Interconnection Customer shall cooperate with each other in good faith in obtaining any such permits, licenses and authorizations. With respect to this paragraph, Transmission Provider or Transmission Owner shall provide permitting assistance to Interconnection Customer comparable to that provided to Transmission Provider's own, or an Affiliate's generation.
- 5.15 Early Construction of Base Case Facilities.** Interconnection Customer may request Transmission Provider to construct, and Transmission Provider shall construct, using Reasonable Efforts to accommodate Interconnection Customer's In-Service Date, all or any portion of any Network Upgrades required for Interconnection Customer to be interconnected to the Transmission System which are included in the Base Case of the Facilities Study for Interconnection Customer, and which also are required to be constructed for another Interconnection Customer, but where such construction is not scheduled to be completed in time to achieve Interconnection Customer's In-Service Date.
- 5.16 Suspension.** Interconnection Customer reserves the right, upon written notice to Transmission Provider, to suspend at any time all work by Transmission Provider associated with the construction and installation of Transmission Provider's Interconnection Facilities and/or Network Upgrades required under this LGIA with the condition that Transmission System shall be left in a safe and reliable condition in accordance with Good Utility Practice and Transmission Provider's safety and reliability criteria. In such event, Interconnection Customer shall be responsible for all reasonable and necessary costs which Transmission Provider (i) has incurred pursuant to this LGIA prior to the suspension and (ii) incurs in suspending such work, including any costs incurred to perform such work as may be necessary to ensure the safety of persons and property and the integrity of the

Transmission System during such suspension and, if applicable, any costs incurred in connection with the cancellation or suspension of material, equipment and labor contracts which Transmission Provider cannot reasonably avoid; provided, however, that prior to canceling or suspending any such material, equipment or labor contract, Transmission Provider shall obtain Interconnection Customer's authorization to do so.

Transmission Provider shall invoice Interconnection Customer for such costs pursuant to Article 12 and shall use due diligence to minimize its costs. In the event Interconnection Customer suspends work by Transmission Provider required under this LGIA pursuant to this Article 5.16, and has not requested Transmission Provider to recommence the work required under this LGIA on or before the expiration of three (3) years following commencement of such suspension, this LGIA shall be deemed terminated. The three-year period shall begin on the date the suspension is requested, or the date of the written notice to Transmission Provider, if no effective date is specified.

5.17 Taxes.

5.17.1 Interconnection Customer Payments Not Taxable. The Parties intend that all payments or property transfers made by Interconnection Customer to Transmission Provider for the installation of Transmission Provider's Interconnection Facilities and the Network Upgrades shall be non-taxable, either as contributions to capital, or as an advance, in accordance with the Internal Revenue Code and any applicable state income tax laws and shall not be taxable as contributions in aid of construction or otherwise under the Internal Revenue Code and any applicable state income tax laws.

5.17.2 Representations and Covenants. In accordance with IRS Notice 2001-82 and IRS Notice 88-129, Interconnection Customer represents and covenants that (i) ownership of the electricity generated at the Large Generating Facility will pass to another party prior to the transmission of the electricity on the Transmission System, (ii) for income tax purposes, the amount of any payments and the cost of any property transferred to Transmission Provider for Transmission Provider's Interconnection Facilities will be capitalized by Interconnection Customer as an intangible asset and recovered using the straight-line method over a useful life of twenty (20) years, and (iii) any portion of Transmission Provider's Interconnection Facilities that is a "dual-use intertie," within the meaning of IRS

Notice 88-129, is reasonably expected to carry only a de minimis amount of electricity in the direction of the Large Generating Facility. For this purpose, "de minimis amount" means no more than 5 percent of the total power flows in both directions, calculated in accordance with the "5 percent test" set forth in IRS Notice 88-129. This is not intended to be an exclusive list of the relevant conditions that must be met to conform to IRS requirements for non-taxable treatment.

At Transmission Provider's request, Interconnection Customer shall provide Transmission Provider with a report from an independent engineer confirming its representation in clause (iii), above. Transmission Provider represents and covenants that the cost of Transmission Provider's Interconnection Facilities paid for by Interconnection Customer will have no net effect on the base upon which rates are determined.

5.17.3 Indemnification for the Cost Consequences of Current Tax Liability Imposed Upon the Transmission Provider.

Notwithstanding Article 5.17.1, Interconnection Customer shall protect, indemnify and hold harmless Transmission Provider from the cost consequences of any current tax liability imposed against Transmission Provider as the result of payments or property transfers made by Interconnection Customer to Transmission Provider under this LGIA for Interconnection Facilities, as well as any interest and penalties, other than interest and penalties attributable to any delay caused by Transmission Provider.

Transmission Provider shall not include a gross-up for the cost consequences of any current tax liability in the amounts it charges Interconnection Customer under this LGIA unless (i) Transmission Provider has determined, in good faith, that the payments or property transfers made by Interconnection Customer to Transmission Provider should be reported as income subject to taxation or (ii) any Governmental Authority directs Transmission Provider to report payments or property as income subject to taxation; provided, however, that Transmission Provider may require Interconnection Customer to provide security for Interconnection Facilities, in a form reasonably acceptable to Transmission Provider (such as a parental guarantee or a letter of credit), in an amount equal to the cost consequences of any current tax liability under this Article 5.17.

Interconnection Customer shall reimburse Transmission Provider for such costs on a fully grossed-up basis, in accordance with Article 5.17.4, within thirty (30) Calendar Days of receiving written notification from Transmission Provider of the amount due, including detail about how the amount was calculated.

The indemnification obligation shall terminate at the earlier of (1) the expiration of the ten year testing period and the applicable statute of limitation, as it may be extended by Transmission Provider upon request of the IRS, to keep these years open for audit or adjustment, or (2) the occurrence of a subsequent taxable event and the payment of any related indemnification obligations as contemplated by this Article 5.17.

5.17.4 Tax Gross-Up Amount. Interconnection Customer's liability for the cost consequences of any current tax liability under this Article 5.17 shall be calculated on a fully grossed-up basis. Except as may otherwise be agreed to by the parties, this means that Interconnection Customer will pay Transmission Provider, in addition to the amount paid for the Interconnection Facilities and Network Upgrades, an amount equal to (1) the current taxes imposed on Transmission Provider ("Current Taxes") on the excess of (a) the gross income realized by Transmission Provider as a result of payments or property transfers made by Interconnection Customer to Transmission Provider under this LGIA (without regard to any payments under this Article 5.17) (the "Gross Income Amount") over (b) the present value of future tax deductions for depreciation that will be available as a result of such payments or property transfers (the "Present Value Depreciation Amount"), plus (2) an additional amount sufficient to permit Transmission Provider to receive and retain, after the payment of all Current Taxes, an amount equal to the net amount described in clause (1).

For this purpose, (i) Current Taxes shall be computed based on Transmission Provider's composite federal and state tax rates at the time the payments or property transfers are received and Transmission Provider will be treated as being subject to tax at the highest marginal rates in effect at that time (the "Current Tax Rate"), and (ii) the Present Value Depreciation Amount shall be computed by discounting Transmission Provider's anticipated tax depreciation deductions as a result of such payments or property transfers by

Transmission Provider's current weighted average cost of capital. Thus, the formula for calculating Interconnection Customer's liability to Transmission Owner pursuant to this Article 5.17.4 can be expressed as follows: $(\text{Current Tax Rate} \times (\text{Gross Income Amount} - \text{Present Value of Tax Depreciation})) / (1 - \text{Current Tax Rate})$. Interconnection Customer's estimated tax liability in the event taxes are imposed shall be stated in Appendix A, Interconnection Facilities, Network Upgrades and Distribution Upgrades.

5.17.5 Private Letter Ruling or Change or Clarification of Law. At Interconnection Customer's request and expense, Transmission Provider shall file with the IRS a request for a private letter ruling as to whether any property transferred or sums paid, or to be paid, by Interconnection Customer to Transmission Provider under this LGIA are subject to federal income taxation. Interconnection Customer will prepare the initial draft of the request for a private letter ruling, and will certify under penalties of perjury that all facts represented in such request are true and accurate to the best of Interconnection Customer's knowledge. Transmission Provider and Interconnection Customer shall cooperate in good faith with respect to the submission of such request.

Transmission Provider shall keep Interconnection Customer fully informed of the status of such request for a private letter ruling and shall execute either a privacy act waiver or a limited power of attorney, in a form acceptable to the IRS, that authorizes Interconnection Customer to participate in all discussions with the IRS regarding such request for a private letter ruling. Transmission Provider shall allow Interconnection Customer to attend all meetings with IRS officials about the request and shall permit Interconnection Customer to prepare the initial drafts of any follow-up letters in connection with the request.

5.17.6 Subsequent Taxable Events. If, within 10 years from the date on which the relevant Transmission Provider's Interconnection Facilities are placed in service, (i) Interconnection Customer Breaches the covenants contained in Article 5.17.2, (ii) a "disqualification event" occurs within the meaning of IRS Notice 88-129, or (iii) this LGIA terminates and Transmission Provider retains ownership of the Interconnection Facilities and Network Upgrades, Interconnection Customer shall pay a tax gross-up for the cost consequences of any

current tax liability imposed on Transmission Provider, calculated using the methodology described in Article 5.17.4 and in accordance with IRS Notice 90-60.

5.17.7

Contests. In the event any Governmental Authority determines that Transmission Provider's receipt of payments or property constitutes income that is subject to taxation, Transmission Provider shall notify Interconnection Customer, in writing, within thirty (30) Calendar Days of receiving notification of such determination by a Governmental Authority. Upon the timely written request by Interconnection Customer and at Interconnection Customer's sole expense, Transmission Provider may appeal, protest, seek abatement of, or otherwise oppose such determination. Upon Interconnection Customer's written request and sole expense, Transmission Provider may file a claim for refund with respect to any taxes paid under this Article 5.17, whether or not it has received such a determination. Transmission Provider reserves the right to make all decisions with regard to the prosecution of such appeal, protest, abatement or other contest, including the selection of counsel and compromise or settlement of the claim, but Transmission Provider shall keep Interconnection Customer informed, shall consider in good faith suggestions from Interconnection Customer about the conduct of the contest, and shall reasonably permit Interconnection Customer or an Interconnection Customer representative to attend contest proceedings.

Interconnection Customer shall pay to Transmission Provider on a periodic basis, as invoiced by Transmission Provider, Transmission Provider's documented reasonable costs of prosecuting such appeal, protest, abatement or other contest. At any time during the contest, Transmission Provider may agree to a settlement either with Interconnection Customer's consent or after obtaining written advice from nationally-recognized tax counsel, selected by Transmission Provider, but reasonably acceptable to Interconnection Customer, that the proposed settlement represents a reasonable settlement given the hazards of litigation. Interconnection Customer's obligation shall be based on the amount of the settlement agreed to by Interconnection Customer, or if a higher amount, so much of the settlement that is supported by the written advice from nationally-recognized tax counsel selected under the terms of the preceding sentence. Any settlement without Interconnection Customer's

consent or such written advice will relieve Interconnection Customer from any obligation to indemnify Transmission Provider for the tax at issue in the contest.

5.17.8 Refund. In the event that (a) a private letter ruling is issued to Transmission Provider which holds that any amount paid or the value of any property transferred by Interconnection Customer to Transmission Provider under the terms of this LGIA is not subject to federal income taxation, (b) any legislative change or administrative announcement, notice, ruling or other determination makes it reasonably clear to Transmission Provider in good faith that any amount paid or the value of any property transferred by Interconnection Customer to Transmission Provider under the terms of this LGIA is not taxable to Transmission Provider, (c) any abatement, appeal, protest, or other contest results in a determination that any payments or transfers made by Interconnection Customer to Transmission Provider are not subject to federal income tax, or (d) if Transmission Provider receives a refund from any taxing authority for any overpayment of tax attributable to any payment or property transfer made by Interconnection Customer to Transmission Provider pursuant to this LGIA, Transmission Provider shall promptly refund to Interconnection Customer the following:

(i) any payment made by Interconnection Customer under this Article 5.17 for taxes that is attributable to the amount determined to be non-taxable, together with interest thereon,

(ii) on any amounts paid by Interconnection Customer to Transmission Provider for such taxes which Transmission Provider did not submit to the taxing authority, calculated in accordance with the methodology set forth in FERC's regulations at 18 CFR §35.19a(a)(2)(ii) from the date payment was made by Interconnection Customer to the date Transmission Provider refunds such payment to Interconnection Customer, and

(iii) with respect to any such taxes paid by Transmission Provider, any refund or credit Transmission Provider receives or to which it may be entitled from any Governmental Authority, interest (or that portion thereof attributable to the payment described in clause (i), above) owed to Transmission

Provider for such overpayment of taxes (including any reduction in interest otherwise payable by Transmission Provider to any Governmental Authority resulting from an offset or credit); provided, however, that Transmission Provider will remit such amount promptly to Interconnection Customer only after and to the extent that Transmission Provider has received a tax refund, credit or offset from any Governmental Authority for any applicable overpayment of income tax related to Transmission Provider's Interconnection Facilities.

The intent of this provision is to leave the Parties, to the extent practicable, in the event that no taxes are due with respect to any payment for Interconnection Facilities and Network Upgrades hereunder, in the same position they would have been in had no such tax payments been made.

- 5.17.9 Taxes Other Than Income Taxes.** Upon the timely request by Interconnection Customer, and at Interconnection Customer's sole expense, Transmission Provider may appeal, protest, seek abatement of, or otherwise contest any tax (other than federal or state income tax) asserted or assessed against Transmission Provider for which Interconnection Customer may be required to reimburse Transmission Provider under the terms of this LGIA. Interconnection Customer shall pay to Transmission Provider on a periodic basis, as invoiced by Transmission Provider, Transmission Provider's documented reasonable costs of prosecuting such appeal, protest, abatement, or other contest. Interconnection Customer and Transmission Provider shall cooperate in good faith with respect to any such contest. Unless the payment of such taxes is a prerequisite to an appeal or abatement or cannot be deferred, no amount shall be payable by Interconnection Customer to Transmission Provider for such taxes until they are assessed by a final, non-appealable order by any court or agency of competent jurisdiction. In the event that a tax payment is withheld and ultimately due and payable after appeal, Interconnection Customer will be responsible for all taxes, interest and penalties, other than penalties attributable to any delay caused by Transmission Provider.

- 5.17.10 Transmission Owners Who Are Not Transmission Providers.** If Transmission Provider is not the same entity as the Transmission

Owner, then (i) all references in this Article 5.17 to Transmission Provider shall be deemed also to refer to and to include the Transmission Owner, as appropriate, and (ii) this LGIA shall not become effective until such Transmission Owner shall have agreed in writing to assume all of the duties and obligations of Transmission Provider under this Article 5.17 of this LGIA.

5.18 Tax Status. Each Party shall cooperate with the other to maintain the other Party's tax status. Nothing in this LGIA is intended to adversely affect any Transmission Provider's tax exempt status with respect to the issuance of bonds including, but not limited to, Local Furnishing Bonds.

5.19 Modification.

5.19.1 General. Either Party may undertake modifications to its facilities. If a Party plans to undertake a modification that reasonably may be expected to affect the other Party's facilities, that Party shall provide to the other Party sufficient information regarding such modification so that the other Party may evaluate the potential impact of such modification prior to commencement of the work. Such information shall be deemed to be confidential hereunder and shall include information concerning the timing of such modifications and whether such modifications are expected to interrupt the flow of electricity from the Large Generating Facility. The Party desiring to perform such work shall provide the relevant drawings, plans, and specifications to the other Party at least ninety (90) Calendar Days in advance of the commencement of the work or such shorter period upon which the Parties may agree, which agreement shall not unreasonably be withheld, conditioned or delayed.

In the case of Large Generating Facility modifications that do not require Interconnection Customer to submit an Interconnection Request, Transmission Provider shall provide, within thirty (30) Calendar Days (or such other time as the Parties may agree), an estimate of any additional modifications to the Transmission System, Transmission Provider's Interconnection Facilities or Network Upgrades necessitated by such Interconnection Customer modification and a good faith estimate of the costs thereof.

5.19.2 Standards. Any additions, modifications, or replacements made to a Party's facilities shall be designed, constructed and operated in

accordance with this LGIA and Good Utility Practice.

- 5.19.3 Modification Costs.** Interconnection Customer shall not be directly assigned for the costs of any additions, modifications, or replacements that Transmission Provider makes to Transmission Provider's Interconnection Facilities or the Transmission System to facilitate the interconnection of a third party to Transmission Provider's Interconnection Facilities or the Transmission System, or to provide transmission service to a third party under Transmission Provider's Tariff. Interconnection Customer shall be responsible for the costs of any additions, modifications, or replacements to Interconnection Customer's Interconnection Facilities that may be necessary to maintain or upgrade such Interconnection Customer's Interconnection Facilities consistent with Applicable Laws and Regulations, Applicable Reliability Standards or Good Utility Practice.

Article 6. Testing and Inspection

- 6.1 Pre-Commercial Operation Date Testing and Modifications.** Prior to the Commercial Operation Date, Transmission Provider shall test Transmission Provider's Interconnection Facilities and Network Upgrades and Interconnection Customer shall test the Large Generating Facility and Interconnection Customer's Interconnection Facilities to ensure their safe and reliable operation. Similar testing may be required after initial operation. Each Party shall make any modifications to its facilities that are found to be necessary as a result of such testing. Interconnection Customer shall bear the cost of all such testing and modifications. Interconnection Customer shall generate test energy at the Large Generating Facility only if it has arranged for the delivery of such test energy.
- 6.2 Post-Commercial Operation Date Testing and Modifications.** Each Party shall at its own expense perform routine inspection and testing of its facilities and equipment in accordance with Good Utility Practice as may be necessary to ensure the continued interconnection of the Large Generating Facility with the Transmission System in a safe and reliable manner. Each Party shall have the right, upon advance written notice, to require reasonable additional testing of the other Party's facilities, at the requesting Party's expense, as may be in accordance with Good Utility Practice.
- 6.3 Right to Observe Testing.** Each Party shall notify the other Party in advance of

its performance of tests of its Interconnection Facilities. The other Party has the right, at its own expense, to observe such testing.

- 6.4 Right to Inspect.** Each Party shall have the right, but shall have no obligation to:
- (i) observe the other Party's tests and/or inspection of any of its System Protection Facilities and other protective equipment, including Power System Stabilizers;
 - (ii) review the settings of the other Party's System Protection Facilities and other protective equipment; and
 - (iii) review the other Party's maintenance records relative to the Interconnection Facilities, the System Protection Facilities and other protective equipment.
- A Party may exercise these rights from time to time as it deems necessary upon reasonable notice to the other Party. The exercise or non-exercise by a Party of any such rights shall not be construed as an endorsement or confirmation of any element or condition of the Interconnection Facilities or the System Protection Facilities or other protective equipment or the operation thereof, or as a warranty as to the fitness, safety, desirability, or reliability of same. Any information that a Party obtains through the exercise of any of its rights under this Article 6.4 shall be deemed to be Confidential Information and treated pursuant to Article 22 of this LGIA.

Article 7. Metering

- 7.1 General.** Each Party shall comply with the Applicable Reliability Council requirements. Unless otherwise agreed by the Parties, Transmission Provider shall install Metering Equipment at the Point of Interconnection prior to any operation of the Large Generating Facility and shall own, operate, test and maintain such Metering Equipment. Power flows to and from the Large Generating Facility shall be measured at or, at Transmission Provider's option, compensated to, the Point of Interconnection. Transmission Provider shall provide metering quantities, in analog and/or digital form, to Interconnection Customer upon request. Interconnection Customer shall bear all reasonable documented costs associated with the purchase, installation, operation, testing and maintenance of the Metering Equipment.
- 7.2 Check Meters.** Interconnection Customer, at its option and expense, may install and operate, on its premises and on its side of the Point of Interconnection, one or more check meters to check Transmission Provider's meters. Such check meters shall be for check purposes only and shall not be used for the measurement of power flows for purposes of this LGIA, except as provided in Article 7.4 below. The check meters shall be subject at all reasonable times to inspection and examination by Transmission Provider or its designee. The installation, operation

and maintenance thereof shall be performed entirely by Interconnection Customer in accordance with Good Utility Practice.

7.3 Standards. Transmission Provider shall install, calibrate, and test revenue quality Metering Equipment in accordance with applicable ANSI standards.

7.4 Testing of Metering Equipment. Transmission Provider shall inspect and test all Transmission Provider-owned Metering Equipment upon installation and at least once every two (2) years thereafter. If requested to do so by Interconnection Customer, Transmission Provider shall, at Interconnection Customer's expense, inspect or test Metering Equipment more frequently than every two (2) years. Transmission Provider shall give reasonable notice of the time when any inspection or test shall take place, and Interconnection Customer may have representatives present at the test or inspection. If at any time Metering Equipment is found to be inaccurate or defective, it shall be adjusted, repaired or replaced at Interconnection Customer's expense, in order to provide accurate metering, unless the inaccuracy or defect is due to Transmission Provider's failure to maintain, then Transmission Provider shall pay. If Metering Equipment fails to register, or if the measurement made by Metering Equipment during a test varies by more than two percent from the measurement made by the standard meter used in the test, Transmission Provider shall adjust the measurements by correcting all measurements for the period during which Metering Equipment was in error by using Interconnection Customer's check meters, if installed. If no such check meters are installed or if the period cannot be reasonably ascertained, the adjustment shall be for the period immediately preceding the test of the Metering Equipment equal to one-half the time from the date of the last previous test of the Metering Equipment.

7.5 Metering Data. At Interconnection Customer's expense, the metered data shall be telemetered to one or more locations designated by Transmission Provider and one or more locations designated by Interconnection Customer. Such telemetered data shall be used, under normal operating conditions, as the official measurement of the amount of energy delivered from the Large Generating Facility to the Point of Interconnection.

Article 8. Communications

8.1 Interconnection Customer Obligations. Interconnection Customer shall maintain satisfactory operating communications with Transmission Provider's Transmission System dispatcher or representative designated by Transmission

Provider. Interconnection Customer shall provide standard voice line, dedicated voice line and facsimile communications at its Large Generating Facility control room or central dispatch facility through use of either the public telephone system, or a voice communications system that does not rely on the public telephone system. Interconnection Customer shall also provide the dedicated data circuit(s) necessary to provide Interconnection Customer data to Transmission Provider as set forth in Appendix D, Security Arrangements Details. The data circuit(s) shall extend from the Large Generating Facility to the location(s) specified by Transmission Provider. Any required maintenance of such communications equipment shall be performed by Interconnection Customer. Operational communications shall be activated and maintained under, but not be limited to, the following events: system paralleling or separation, scheduled and unscheduled shutdowns, equipment clearances, and hourly and daily load data.

8.2 Remote Terminal Unit. Prior to the Initial Synchronization Date of the Large Generating Facility, a Remote Terminal Unit, or equivalent data collection and transfer equipment acceptable to the Parties, shall be installed by Interconnection Customer, or by Transmission Provider at Interconnection Customer's expense, to gather accumulated and instantaneous data to be telemetered to the location(s) designated by Transmission Provider through use of a dedicated point-to-point data circuit(s) as indicated in Article 8.1. The communication protocol for the data circuit(s) shall be specified by Transmission Provider. Instantaneous bi-directional analog real power and reactive power flow information must be telemetered directly to the location(s) specified by Transmission Provider.

Each Party will promptly advise the other Party if it detects or otherwise learns of any metering, telemetry or communications equipment errors or malfunctions that require the attention and/or correction by the other Party. The Party owning such equipment shall correct such error or malfunction as soon as reasonably feasible.

8.3 No Annexation. Any and all equipment placed on the premises of a Party shall be and remain the property of the Party providing such equipment regardless of the mode and manner of annexation or attachment to real property, unless otherwise mutually agreed by the Parties.

Article 9. Operations

9.1 General. Each Party shall comply with the Applicable Reliability Council requirements. Each Party shall provide to the other Party all information that may reasonably

be required by the other Party to comply with Applicable Laws and Regulations and Applicable Reliability Standards.

- 9.2 Control Area Notification.** At least three months before Initial Synchronization Date, Interconnection Customer shall notify Transmission Provider in writing of the Control Area in which the Large Generating Facility will be located. If Interconnection Customer elects to locate the Large Generating Facility in a Control Area other than the Control Area in which the Large Generating Facility is physically located, and if permitted to do so by the relevant transmission tariffs, all necessary arrangements, including but not limited to those set forth in Article 7 and Article 8 of this LGIA, and remote Control Area generator interchange agreements, if applicable, and the appropriate measures under such agreements, shall be executed and implemented prior to the placement of the Large Generating Facility in the other Control Area.
- 9.3 Transmission Provider Obligations.** Transmission Provider shall cause the Transmission System and Transmission Provider's Interconnection Facilities to be operated, maintained and controlled in a safe and reliable manner and in accordance with this LGIA. Transmission Provider may provide operating instructions to Interconnection Customer consistent with this LGIA and Transmission Provider's operating protocols and procedures as they may change from time to time. Transmission Provider will consider changes to its operating protocols and procedures proposed by Interconnection Customer.
- 9.4 Interconnection Customer Obligations.** Interconnection Customer shall at its own expense operate, maintain and control the Large Generating Facility and Interconnection Customer's Interconnection Facilities in a safe and reliable manner and in accordance with this LGIA. Interconnection Customer shall operate the Large Generating Facility and Interconnection Customer's Interconnection Facilities in accordance with all applicable requirements of the Control Area of which it is part, as such requirements are set forth in Appendix C, Interconnection Details, of this LGIA. Appendix C, Interconnection Details, will be modified to reflect changes to the requirements as they may change from time to time. Either Party may request that the other Party provide copies of the requirements set forth in Appendix C, Interconnection Details, of this LGIA.
- 9.5 Start-Up and Synchronization.** Consistent with the Parties' mutually acceptable procedures, Interconnection Customer is responsible for the proper synchronization of the Large Generating Facility to Transmission Provider's Transmission System.

9.6 Reactive Power.

9.6.1 Power Factor Design Criteria. Interconnection Customer shall design the Large Generating Facility to maintain a composite power delivery at continuous rated power output at the Point of Interconnection at a power factor within the range of 0.95 leading to 0.95 lagging, unless Transmission Provider has established different requirements that apply to all generators in the Control Area on a comparable basis. The requirements of this paragraph shall not apply to wind generators.

9.6.2 Voltage Schedules. Once Interconnection Customer has synchronized the Large Generating Facility with the Transmission System, Transmission Provider shall require Interconnection Customer to operate the Large Generating Facility to produce or absorb reactive power within the design limitations of the Large Generating Facility set forth in Article 9.6.1 (Power Factor Design Criteria). Transmission Provider's voltage schedules shall treat all sources of reactive power in the Control Area in an equitable and not unduly discriminatory manner. Transmission Provider shall exercise Reasonable Efforts to provide Interconnection Customer with such schedules at least one (1) day in advance, and may make changes to such schedules as necessary to maintain the reliability of the Transmission System. Interconnection Customer shall operate the Large Generating Facility to maintain the specified output voltage or power factor at the Point of Interconnection within the design limitations of the Large Generating Facility set forth in Article 9.6.1 (Power Factor Design Criteria). If Interconnection Customer is unable to maintain the specified voltage or power factor, it shall promptly notify the System Operator.

9.6.2.1 Governors and Regulators. Whenever the Large Generating Facility is operated in parallel with the Transmission System and the speed governors (if installed on the generating unit pursuant to Good Utility Practice) and voltage regulators are capable of operation, Interconnection Customer shall operate the Large Generating Facility with its speed governors and voltage regulators in automatic operation. If the Large Generating Facility's speed governors and voltage regulators are not capable of such automatic operation, Interconnection Customer shall immediately notify Transmission Provider's system operator, or its designated representative, and ensure that such Large Generating Facility's reactive power production or absorption (measured in MVARs) are within

the design capability of the Large Generating Facility's generating unit(s) and steady state stability limits. Interconnection Customer shall not cause its Large Generating Facility to disconnect automatically or instantaneously from the Transmission System or trip any generating unit comprising the Large Generating Facility for an under or over frequency condition unless the abnormal frequency condition persists for a time period beyond the limits set forth in ANSI/IEEE Standard C37.106, or such other standard as applied to other generators in the Control Area on a comparable basis.

9.6.3 Payment for Reactive Power. Transmission Provider is required to pay Interconnection Customer for reactive power that Interconnection Customer provides or absorbs from the Large Generating Facility when Transmission Provider requests Interconnection Customer to operate its Large Generating Facility outside the range specified in Article 9.6.1, provided that if Transmission Provider pays its own or affiliated generators for reactive power service within the specified range, it must also pay Interconnection Customer. Payments shall be pursuant to Article 11.6 or such other agreement to which the Parties have otherwise agreed.

9.7 Outages and Interruptions.

9.7.1 Outages.

9.7.1.1 Outage Authority and Coordination. Each Party may in accordance with Good Utility Practice in coordination with the other Party remove from service any of its respective Interconnection Facilities or Network Upgrades that may impact the other Party's facilities as necessary to perform maintenance or testing or to install or replace equipment. Absent an Emergency Condition, the Party scheduling a removal of such facility(ies) from service will use Reasonable Efforts to schedule such removal on a date and time mutually acceptable to the Parties. In all circumstances, any Party planning to remove such facility(ies) from service shall use Reasonable Efforts to minimize the effect on the other Party of such removal.

9.7.1.2 Outage Schedules. Transmission Provider shall post

scheduled outages of its transmission facilities on the OASIS. Interconnection Customer shall submit its planned maintenance schedules for the Large Generating Facility to Transmission Provider for a minimum of a rolling twenty-four month period. Interconnection Customer shall update its planned maintenance schedules as necessary. Transmission Provider may request Interconnection Customer to reschedule its maintenance as necessary to maintain the reliability of the Transmission System; provided, however, adequacy of generation supply shall not be a criterion in determining Transmission System reliability. Transmission Provider shall compensate Interconnection Customer for any additional direct costs that Interconnection Customer incurs as a result of having to reschedule maintenance, including any additional overtime, breaking of maintenance contracts or other costs above and beyond the cost Interconnection Customer would have incurred absent Transmission Provider's request to reschedule maintenance. Interconnection Customer will not be eligible to receive compensation, if during the twelve (12) months prior to the date of the scheduled maintenance, Interconnection Customer had modified its schedule of maintenance activities.

9.7.1.3 Outage Restoration. If an outage on a Party's Interconnection Facilities or Network Upgrades adversely affects the other Party's operations or facilities, the Party that owns or controls the facility that is out of service shall use Reasonable Efforts to promptly restore such facility(ies) to a normal operating condition consistent with the nature of the outage. The Party that owns or controls the facility that is out of service shall provide the other Party, to the extent such information is known, information on the nature of the Emergency Condition, an estimated time of restoration, and any corrective actions required. Initial verbal notice shall be followed up as soon as practicable with written notice explaining the nature of the outage.

9.7.2 Interruption of Service. If required by Good Utility Practice to do so, Transmission Provider may require Interconnection Customer to interrupt or reduce deliveries of electricity if such delivery of electricity could adversely affect Transmission Provider's ability to perform such activities as are

necessary to safely and reliably operate and maintain the Transmission System. The following provisions shall apply to any interruption or reduction permitted under this Article 9.7.2:

- 9.7.2.1 The interruption or reduction shall continue only for so long as reasonably necessary under Good Utility Practice;
- 9.7.2.2 Any such interruption or reduction shall be made on an equitable, non-discriminatory basis with respect to all generating facilities directly connected to the Transmission System;
- 9.7.2.3 When the interruption or reduction must be made under circumstances which do not allow for advance notice, Transmission Provider shall notify Interconnection Customer by telephone as soon as practicable of the reasons for the curtailment, interruption, or reduction, and, if known, its expected duration. Telephone notification shall be followed by written notification as soon as practicable;
- 9.7.2.4 Except during the existence of an Emergency Condition, when the interruption or reduction can be scheduled without advance notice, Transmission Provider shall notify Interconnection Customer in advance regarding the timing of such scheduling and further notify Interconnection Customer of the expected duration. Transmission Provider shall coordinate with Interconnection Customer using Good Utility Practice to schedule the interruption or reduction during periods of least impact to Interconnection Customer and Transmission Provider;
- 9.7.2.5 The Parties shall cooperate and coordinate with each other to the extent necessary in order to restore the Large Generating Facility, Interconnection Facilities, and the Transmission System to their normal operating state, consistent with system conditions and Good Utility Practice.

9.7.3 Under-Frequency and Over Frequency Conditions. The Transmission System is designed to automatically activate a load-shed program as required by the Applicable Reliability Council in the event of an under-frequency system disturbance. Interconnection Customer shall implement

under-frequency and over-frequency relay set points for the Large Generating Facility as required by the Applicable Reliability Council to ensure "ride through" capability of the Transmission System. Large Generating Facility response to frequency deviations of pre-determined magnitudes, both under-frequency and over-frequency deviations, shall be studied and coordinated with Transmission Provider in accordance with Good Utility Practice. The term "ride through" as used herein shall mean the ability of a Generating Facility to stay connected to and synchronized with the Transmission System during system disturbances within a range of under-frequency and over-frequency conditions, in accordance with Good Utility Practice.

9.7.4 System Protection and Other Control Requirements.

- 9.7.4.1 System Protection Facilities.** Interconnection Customer shall, at its expense, install, operate and maintain System Protection Facilities as a part of the Large Generating Facility or Interconnection Customer's Interconnection Facilities. Transmission Provider shall install at Interconnection Customer's expense any System Protection Facilities that may be required on Transmission Provider's Interconnection Facilities or the Transmission System as a result of the interconnection of the Large Generating Facility and Interconnection Customer's Interconnection Facilities.
- 9.7.4.2** Each Party's protection facilities shall be designed and coordinated with other systems in accordance with Good Utility Practice.
- 9.7.4.3** Each Party shall be responsible for protection of its facilities consistent with Good Utility Practice.
- 9.7.4.4** Each Party's protective relay design shall incorporate the necessary test switches to perform the tests required in Article 6. The required test switches will be placed such that they allow operation of lockout relays while preventing breaker failure schemes from operating and causing unnecessary breaker operations and/or the tripping of Interconnection Customer's units.
- 9.7.4.5** Each Party will test, operate and maintain System Protection

Facilities in accordance with Good Utility Practice.

9.7.4.6 Prior to the In-Service Date, and again prior to the Commercial Operation Date, each Party or its agent shall perform a complete calibration test and functional trip test of the System Protection Facilities. At intervals suggested by Good Utility Practice and following any apparent malfunction of the System Protection Facilities, each Party shall perform both calibration and functional trip tests of its System Protection Facilities. These tests do not require the tripping of any in-service generation unit. These tests do, however, require that all protective relays and lockout contacts be activated.

9.7.5 Requirements for Protection. In compliance with Good Utility Practice, Interconnection Customer shall provide, install, own, and maintain relays, circuit breakers and all other devices necessary to remove any fault contribution of the Large Generating Facility to any short circuit occurring on the Transmission System not otherwise isolated by Transmission Provider's equipment, such that the removal of the fault contribution shall be coordinated with the protective requirements of the Transmission System. Such protective equipment shall include, without limitation, a disconnecting device or switch with load-interrupting capability located between the Large Generating Facility and the Transmission System at a site selected upon mutual agreement (not to be unreasonably withheld, conditioned or delayed) of the Parties. Interconnection Customer shall be responsible for protection of the Large Generating Facility and Interconnection Customer's other equipment from such conditions as negative sequence currents, over- or under-frequency, sudden load rejection, over- or under-voltage, and generator loss-of-field. Interconnection Customer shall be solely responsible to disconnect the Large Generating Facility and Interconnection Customer's other equipment if conditions on the Transmission System could adversely affect the Large Generating Facility.

9.7.6 Power Quality. Neither Party's facilities shall cause excessive voltage flicker nor introduce excessive distortion to the sinusoidal voltage or current waves as defined by ANSI Standard C84.1-1989, in accordance with IEEE Standard 519, or any applicable superseding electric industry standard. In the event of a conflict between ANSI Standard C84.1-1989, or any applicable superseding electric industry standard, ANSI Standard

C84.1-1989, or the applicable superseding electric industry standard, shall control.

9.8 Switching and Tagging Rules. Each Party shall provide the other Party a copy of its switching and tagging rules that are applicable to the other Party's activities. Such switching and tagging rules shall be developed on a non-discriminatory basis. The Parties shall comply with applicable switching and tagging rules, as amended from time to time, in obtaining clearances for work or for switching operations on equipment.

9.9 Use of Interconnection Facilities by Third Parties.

9.9.1 Purpose of Interconnection Facilities. Except as may be required by Applicable Laws and Regulations, or as otherwise agreed to among the Parties, the Interconnection Facilities shall be constructed for the sole purpose of interconnecting the Large Generating Facility to the Transmission System and shall be used for no other purpose.

9.9.2 Third Party Users. If required by Applicable Laws and Regulations or if the Parties mutually agree, such agreement not to be unreasonably withheld, to allow one or more third parties to use Transmission Provider's Interconnection Facilities, or any part thereof, Interconnection Customer will be entitled to compensation for the capital expenses it incurred in connection with the Interconnection Facilities based upon the pro rata use of the Interconnection Facilities by Transmission Provider, all third party users, and Interconnection Customer, in accordance with Applicable Laws and Regulations or upon some other mutually-agreed upon methodology. In addition, cost responsibility for ongoing costs, including operation and maintenance costs associated with the Interconnection Facilities, will be allocated between Interconnection Customer and any third party users based upon the pro rata use of the Interconnection Facilities by Transmission Provider, all third party users, and Interconnection Customer, in accordance with Applicable Laws and Regulations or upon some other mutually agreed upon methodology. If the issue of such compensation or allocation cannot be resolved through such negotiations, it shall be submitted to FERC for resolution.

9.10 Disturbance Analysis Data Exchange. The Parties will cooperate with one another in the analysis of disturbances to either the Large Generating Facility or Transmission Provider's Transmission System by gathering and providing access to any information relating to any disturbance, including information from

oscillography, protective relay targets, breaker operations and sequence of events records, and any disturbance information required by Good Utility Practice.

Article 10. Maintenance

- 10.1 Transmission Provider Obligations.** Transmission Provider shall maintain the Transmission System and Transmission Provider's Interconnection Facilities in a safe and reliable manner and in accordance with this LGIA.
- 10.2 Interconnection Customer Obligations.** Interconnection Customer shall maintain the Large Generating Facility and Interconnection Customer's Interconnection Facilities in a safe and reliable manner and in accordance with this LGIA.
- 10.3 Coordination.** The Parties shall confer regularly to coordinate the planning, scheduling and performance of preventive and corrective maintenance on the Large Generating Facility and the Interconnection Facilities.
- 10.4 Secondary Systems.** Each Party shall cooperate with the other in the inspection, maintenance, and testing of control or power circuits that operate below 600 volts, AC or DC, including, but not limited to, any hardware, control or protective devices, cables, conductors, electric raceways, secondary equipment panels, transducers, batteries, chargers, and voltage and current transformers that directly affect the operation of a Party's facilities and equipment which may reasonably be expected to impact the other Party. Each Party shall provide advance notice to the other Party before undertaking any work on such circuits, especially on electrical circuits involving circuit breaker trip and close contacts, current transformers, or potential transformers.
- 10.5 Operating and Maintenance Expenses.** Subject to the provisions herein addressing the use of facilities by others, and except for operations and maintenance expenses associated with modifications made for providing interconnection or transmission service to a third party and such third party pays for such expenses, Interconnection Customer shall be responsible for all reasonable expenses including overheads, associated with: (1) owning, operating, maintaining, repairing, and replacing Interconnection Customer's Interconnection Facilities; and (2) operation, maintenance, repair and replacement of Transmission Provider's Interconnection Facilities.

Article 11. Performance Obligation

- 11.1 Interconnection Customer Interconnection Facilities.** Interconnection Customer shall design, procure, construct, install, own and/or control Interconnection Customer Interconnection Facilities described in Appendix A, Interconnection Facilities, Network Upgrades and Distribution Upgrades, at its sole expense.
- 11.2 Transmission Provider's Interconnection Facilities.** Transmission Provider or Transmission Owner shall design, procure, construct, install, own and/or control the Transmission Provider's Interconnection Facilities described in Appendix A, Interconnection Facilities, Network Upgrades and Distribution Upgrades, at the sole expense of the Interconnection Customer.
- 11.3 Network Upgrades and Distribution Upgrades.** Transmission Provider or Transmission Owner shall design, procure, construct, install, and own the Network Upgrades and Distribution Upgrades described in Appendix A, Interconnection Facilities, Network Upgrades and Distribution Upgrades. The Interconnection Customer shall be responsible for all costs related to Distribution Upgrades. Unless Transmission Provider or Transmission Owner elects to fund the capital for the Network Upgrades, they shall be solely funded by Interconnection Customer.
- 11.4 Transmission Credits.**
- 11.4.1 Repayment of Amounts Advanced for Network Upgrades.**
Interconnection Customer shall be entitled to a cash repayment, equal to the total amount paid to Transmission Provider and Affected System Operator, if any, for the Network Upgrades, including any tax gross-up or other tax-related payments associated with Network Upgrades, and not refunded to Interconnection Customer pursuant to Article 5.17.8 or otherwise, to be paid to Interconnection Customer on a dollar-for-dollar basis for the non-usage sensitive portion of transmission charges, as payments are made under Transmission Provider's Tariff and Affected System's Tariff for transmission services with respect to the Large Generating Facility. Any repayment shall include interest calculated in accordance with the methodology set forth in FERC's regulations at 18 C.F.R. § 35.19a(a)(2)(ii) from the date of any payment for Network Upgrades through the date on which the Interconnection Customer

receives a repayment of such payment pursuant to this subparagraph. Interconnection Customer may assign such repayment rights to any person.

Notwithstanding the foregoing, Interconnection Customer, Transmission Provider, and Affected System Operator may adopt any alternative payment schedule that is mutually agreeable so long as Transmission Provider and Affected System Operator take one of the following actions no later than five years from the Commercial Operation Date: (1) return to Interconnection Customer any amounts advanced for Network Upgrades not previously repaid, or (2) declare in writing that Transmission Provider or Affected System Operator will continue to provide payments to Interconnection Customer pursuant to this subparagraph until all amounts advanced for Network Upgrades have been repaid.

If the Large Generating Facility fails to achieve commercial operation, but it or another Generating Facility is later constructed and makes use of the Network Upgrades, Transmission Provider and Affected System Operator shall at that time reimburse Interconnection Customer for the amounts advanced for the Network Upgrades.

11.4.2 Special Provisions for Affected Systems. Unless Transmission Provider provides, under the LGIA, for the repayment of amounts advanced to Affected System Operator for Network Upgrades, Interconnection Customer and Affected System Operator shall enter into an agreement that provides for such repayment. The agreement shall specify the terms governing payments to be made by Interconnection Customer to the Affected System Operator as well as the repayment by the Affected System Operator.

11.4.3 Notwithstanding any other provision of this LGIA, nothing herein shall be construed as relinquishing or foreclosing any rights, including but not limited to firm transmission rights, capacity rights, transmission congestion rights, or transmission credits, that Interconnection Customer, shall be entitled to, now or in the future under any other agreement or tariff as a result of, or otherwise associated with, the transmission capacity, if any, created by the Network Upgrades, including the right to obtain cash reimbursements or transmission

credits for transmission service that is not associated with the Large Generating Facility.

11.5 Provision of Security. At least thirty (30) Calendar Days prior to the commencement of the procurement, installation, or construction of a discrete portion of a Transmission Provider's Interconnection Facilities, Network Upgrades, or Distribution Upgrades, Interconnection Customer shall provide Transmission Provider, at Interconnection Customer's option, a guarantee, a surety bond, letter of credit or other form of security that is reasonably acceptable to Transmission Provider and is consistent with the Uniform Commercial Code of the jurisdiction identified in Article 14.2.1. Such security for payment shall be in an amount sufficient to cover the costs for constructing, procuring and installing the applicable portion of Transmission Provider's Interconnection Facilities, Network Upgrades, or Distribution Upgrades and shall be reduced on a dollar-for-dollar basis for payments made to Transmission Provider for these purposes.

In addition:

11.5.1 The guarantee must be made by an entity that meets the creditworthiness requirements of Transmission Provider, and contain terms and conditions that guarantee payment of any amount that may be due from Interconnection Customer, up to an agreed-to maximum amount.

11.5.2 The letter of credit must be issued by a financial institution reasonably acceptable to Transmission Provider and must specify a reasonable expiration date.

11.5.3 The surety bond must be issued by an insurer reasonably acceptable to Transmission Provider and must specify a reasonable expiration date.

11.6 Interconnection Customer Compensation. If Transmission Provider requests or directs Interconnection Customer to provide a service pursuant to Articles 9.6.3 (Payment for Reactive Power), or 13.5.1 of this LGIA, Transmission Provider shall compensate Interconnection Customer in accordance with Interconnection Customer's applicable rate schedule then in effect unless the provision of such service(s) is subject to an RTO or ISO FERC-approved rate schedule. Interconnection Customer shall serve Transmission Provider or RTO or ISO with any filing of a proposed rate schedule at the time of such filing with FERC. To the extent that no rate schedule is in effect at the time the Interconnection Customer is required to provide or absorb any Reactive Power under this LGIA, Transmission

Provider agrees to compensate Interconnection Customer in such amount as would have been due Interconnection Customer had the rate schedule been in effect at the time service commenced; provided, however, that such rate schedule must be filed at FERC or other appropriate Governmental Authority within sixty (60) Calendar Days of the commencement of service.

11.6.1 Interconnection Customer Compensation for Actions During

Emergency Condition. Transmission Provider or RTO or ISO shall compensate Interconnection Customer for its provision of real and reactive power and other Emergency Condition services that Interconnection Customer provides to support the Transmission System during an Emergency Condition in accordance with Article 11.6.

Article 12. Invoice

12.1 General. Each Party shall submit to the other Party, on a monthly basis, invoices of amounts due for the preceding month. Each invoice shall state the month to which the invoice applies and fully describe the services and equipment provided. The Parties may discharge mutual debts and payment obligations due and owing to each other on the same date through netting, in which case all amounts a Party owes to the other Party under this LGIA, including interest payments or credits, shall be netted so that only the net amount remaining due shall be paid by the owing Party.

12.2 Final Invoice. Within six months after completion of the construction of Transmission Provider's Interconnection Facilities and the Network Upgrades, Transmission Provider shall provide an invoice of the final cost of the construction of Transmission Provider's Interconnection Facilities and the Network Upgrades and shall set forth such costs in sufficient detail to enable Interconnection Customer to compare the actual costs with the estimates and to ascertain deviations, if any, from the cost estimates. Transmission Provider shall refund to Interconnection Customer any amount by which the actual payment by Interconnection Customer for estimated costs exceeds the actual costs of construction within thirty (30) Calendar Days of the issuance of such final construction invoice.

12.3 Payment. Invoices shall be rendered to the paying Party at the address specified in Appendix F. The Party receiving the invoice shall pay the invoice within thirty (30) Calendar Days of receipt. All payments shall be made in immediately available funds payable to the other Party, or by wire transfer to a bank named and

account designated by the invoicing Party. Payment of invoices by either Party will not constitute a waiver of any rights or claims either Party may have under this LGIA.

12.4 Disputes. In the event of a billing dispute between Transmission Provider and Interconnection Customer, Transmission Provider shall continue to provide Interconnection Service under this LGIA as long as Interconnection Customer: (i) continues to make all payments not in dispute; and (ii) pays to Transmission Provider or into an independent escrow account the portion of the invoice in dispute, pending resolution of such dispute. If Interconnection Customer fails to meet these two requirements for continuation of service, then Transmission Provider may provide notice to Interconnection Customer of a Default pursuant to Article 17. Within thirty (30) Calendar Days after the resolution of the dispute, the Party that owes money to the other Party shall pay the amount due with interest calculated in accord with the methodology set forth in FERC's regulations at 18 CFR § 35.19a(a)(2)(ii).

Article 13. Emergencies

13.1 Definition. "Emergency Condition" shall mean a condition or situation: (i) that in the judgment of the Party making the claim is imminently likely to endanger life or property; or (ii) that, in the case of Transmission Provider, is imminently likely (as determined in a non-discriminatory manner) to cause a material adverse effect on the security of, or damage to the Transmission System, Transmission Provider's Interconnection Facilities or the Transmission Systems of others to which the Transmission System is directly connected; or (iii) that, in the case of Interconnection Customer, is imminently likely (as determined in a non-discriminatory manner) to cause a material adverse effect on the security of, or damage to, the Large Generating Facility or Interconnection Customer's Interconnection Facilities' System restoration and black start shall be considered Emergency Conditions; provided, that Interconnection Customer is not obligated by this LGIA to possess black start capability.

13.2 Obligations. Each Party shall comply with the Emergency Condition procedures of the applicable ISO/RTO, NERC, the Applicable Reliability Council, Applicable Laws and Regulations, and any emergency procedures agreed to by the Joint Operating Committee.

13.3 Notice. Transmission Provider shall notify Interconnection Customer promptly when it becomes aware of an Emergency Condition that affects Transmission Provider's Interconnection Facilities or the Transmission System that may

reasonably be expected to affect Interconnection Customer's operation of the Large Generating Facility or Interconnection Customer's Interconnection Facilities. Interconnection Customer shall notify Transmission Provider promptly when it becomes aware of an Emergency Condition that affects the Large Generating Facility or Interconnection Customer's Interconnection Facilities that may reasonably be expected to affect the Transmission System or Transmission Provider's Interconnection Facilities. To the extent information is known, the notification shall describe the Emergency Condition, the extent of the damage or deficiency, the expected effect on the operation of Interconnection Customer's or Transmission Provider's facilities and operations, its anticipated duration and the corrective action taken and/or to be taken. The initial notice shall be followed as soon as practicable with written notice.

13.4 Immediate Action. Unless, in Interconnection Customer's reasonable judgment, immediate action is required, Interconnection Customer shall obtain the consent of Transmission Provider, such consent to not be unreasonably withheld, prior to performing any manual switching operations at the Large Generating Facility or Interconnection Customer's Interconnection Facilities in response to an Emergency Condition either declared by Transmission Provider or otherwise regarding the Transmission System.

13.5 Transmission Provider Authority.

13.5.1 General. Transmission Provider may take whatever actions or inactions with regard to the Transmission System or Transmission Provider's Interconnection Facilities it deems necessary during an Emergency Condition in order to (i) preserve public health and safety, (ii) preserve the reliability of the Transmission System or Transmission Provider's Interconnection Facilities, (iii) limit or prevent damage, and (iv) expedite restoration of service.

Transmission Provider shall use Reasonable Efforts to minimize the effect of such actions or inactions on the Large Generating Facility or Interconnection Customer's Interconnection Facilities. Transmission Provider may, on the basis of technical considerations, require the Large Generating Facility to mitigate an Emergency Condition by taking actions necessary and limited in scope to remedy the Emergency Condition, including, but not limited to, directing Interconnection Customer to shut-down, start-up, increase or decrease the real or reactive power output of the Large Generating Facility; implementing a reduction or disconnection pursuant to

Article 13.5.2; directing Interconnection Customer to assist with blackstart (if available) or restoration efforts; or altering the outage schedules of the Large Generating Facility and Interconnection Customer's Interconnection Facilities. Interconnection Customer shall comply with all of Transmission Provider's operating instructions concerning Large Generating Facility real power and reactive power output within the manufacturer's design limitations of the Large Generating Facility's equipment that is in service and physically available for operation at the time, in compliance with Applicable Laws and Regulations.

13.5.2 Reduction and Disconnection. Transmission Provider may reduce Interconnection Service or disconnect the Large Generating Facility or Interconnection Customer's Interconnection Facilities, when such, reduction or disconnection is necessary under Good Utility Practice due to Emergency Conditions. These rights are separate and distinct from any right of curtailment of Transmission Provider pursuant to Transmission Provider's Tariff. When Transmission Provider can schedule the reduction or disconnection in advance, Transmission Provider shall notify Interconnection Customer of the reasons, timing and expected duration of the reduction or disconnection. Transmission Provider shall coordinate with Interconnection Customer using Good Utility Practice to schedule the reduction or disconnection during periods of least impact to Interconnection Customer and Transmission Provider. Any reduction or disconnection shall continue only for so long as reasonably necessary under Good Utility Practice. The Parties shall cooperate with each other to restore the Large Generating Facility, the Interconnection Facilities, and the Transmission System to their normal operating state as soon as practicable consistent with Good Utility Practice.

13.6 Interconnection Customer Authority. Consistent with Good Utility Practice and the LGIA and the LGIP, Interconnection Customer may take actions or inactions with regard to the Large Generating Facility or Interconnection Customer's Interconnection Facilities during an Emergency Condition in order to (i) preserve public health and safety, (ii) preserve the reliability of the Large Generating Facility or Interconnection Customer's Interconnection Facilities, (iii) limit or prevent damage, and (iv) expedite restoration of service. Interconnection Customer shall use Reasonable Efforts to minimize the effect of such actions or inactions on the Transmission System and Transmission Provider's Interconnection Facilities. Transmission Provider shall use Reasonable Efforts to assist

Interconnection Customer in such actions.

13.7 Limited Liability. Except as otherwise provided in Article 11.6.1 of this LGIA, neither Party shall be liable to the other for any action it takes in responding to an Emergency Condition so long as such action is made in good faith and is consistent with Good Utility Practice.

Article 14. Regulatory Requirements and Governing Law

14.1 Regulatory Requirements. Each Party's obligations under this LGIA shall be subject to its receipt of any required approval or certificate from one or more Governmental Authorities in the form and substance satisfactory to the applying Party, or the Party making any required filings with, or providing notice to, such Governmental Authorities, and the expiration of any time period associated therewith. Each Party shall in good faith seek and use its Reasonable Efforts to obtain such other approvals. Nothing in this LGIA shall require Interconnection Customer to take any action that could result in its inability to obtain, or its loss of, status or exemption under the Federal Power Act, the Public Utility Holding Company Act of 1935, as amended, or the Public Utility Regulatory Policies Act of 1978.

14.2 Governing Law.

14.2.1 The validity, interpretation and performance of this LGIA and each of its provisions shall be governed by the laws of the state where the Point of Interconnection is located, without regard to its conflicts of law principles.

14.2.2 This LGIA is subject to all Applicable Laws and Regulations.

14.2.3 Each Party expressly reserves the right to seek changes in, appeal, or otherwise contest any laws, orders, rules, or regulations of a Governmental Authority.

Article 15. Notices.

15.1 General. Unless otherwise provided in this LGIA, any notice, demand or request required or permitted to be given by either Party to the other and any instrument required or permitted to be tendered or delivered by either Party in writing to the other shall be effective when delivered and may be so given, tendered or delivered,

by recognized national courier, or by depositing the same with the United States Postal Service with postage prepaid, for delivery by certified or registered mail, addressed to the Party, or personally delivered to the Party, at the address set out in Appendix F, Addresses for Delivery of Notices and Billings.

Either Party may change the notice information in this LGIA by giving five (5) Business Days written notice prior to the effective date of the change.

15.2 Billings and Payments. Billings and payments shall be sent to the addresses set out in Appendix F.

15.3 Alternative Forms of Notice. Any notice or request required or permitted to be given by a Party to the other and not required by this Agreement to be given in writing may be so given by telephone, facsimile or email to the telephone numbers and email addresses set out in Appendix F.

15.4 Operations and Maintenance Notice . Each Party shall notify the other Party in writing of the identity of the person(s) that it designates as the point(s) of contact with respect to the implementation of Articles 9 and 10.

Article 16. Force Majeure

16.1 Force Majeure.

16.1.1 Economic hardship is not considered a Force Majeure event.

16.1.2 Neither Party shall be considered to be in Default with respect to any obligation hereunder, (including obligations under Article 4), other than the obligation to pay money when due, if prevented from fulfilling such obligation by Force Majeure. A Party unable to fulfill any obligation hereunder (other than an obligation to pay money when due) by reason of Force Majeure shall give notice and the full particulars of such Force Majeure to the other Party in writing or by

telephone as soon as reasonably possible after the occurrence of the cause relied upon. Telephone notices given pursuant to this article shall be confirmed in writing as soon as reasonably possible and shall specifically state full particulars of the Force Majeure, the time and date when the Force Majeure occurred and when the Force Majeure is reasonably expected to cease. The Party affected shall exercise due diligence to remove such disability with reasonable dispatch, but shall not be required to accede or agree to any provision not satisfactory to it in order to settle and terminate a strike or other labor disturbance.

Article 17. Default

17.1 Default

17.1.1 General. No Default shall exist where such failure to discharge an obligation (other than the payment of money) is the result of Force Majeure as defined in this LGIA or the result of an act of omission of the other Party. Upon a Breach, the non-breaching Party shall give written notice of such Breach to the breaching Party. Except as provided in Article 17.1.2, the breaching Party shall have thirty (30) Calendar Days from receipt of the Default notice within which to cure such Breach; provided however, if such Breach is not capable of cure within thirty (30) Calendar Days, the breaching Party shall commence such cure within thirty (30) Calendar Days after notice and continuously and diligently complete such cure within ninety (90) Calendar Days from receipt of the Default notice; and, if cured within such time, the Breach specified in such notice shall cease to exist.

17.1.2 Right to Terminate. If a Breach is not cured as provided in this article, or if a Breach is not capable of being cured within the period provided for herein, the non-breaching Party shall have the right to declare a Default and terminate this LGIA by written notice at any time until cure occurs, and be relieved of any further obligation hereunder and, whether or not that Party terminates this LGIA, to recover from the breaching Party all amounts due hereunder, plus all other damages and remedies to which it is entitled at law or in equity. The provisions of this article will survive termination of this LGIA.

Article 18. Indemnity, Consequential Damages and Insurance

18.1 Indemnity. The Parties shall at all times indemnify, defend, and hold the other Party harmless from, any and all damages, losses, claims, including claims and actions relating to injury to or death of any person or damage to property, demand, suits, recoveries, costs and expenses, court costs, attorney fees, and all other obligations by or to third parties, arising out of or resulting from the other Party's action or inactions of its obligations under this LGIA on behalf of the indemnifying Party, except in cases of gross negligence or intentional wrongdoing by the indemnified Party.

18.1.1 Indemnified Person. If an Indemnified Person is entitled to indemnification under this Article 18 as a result of a claim by a third party, and the indemnifying Party fails, after notice and reasonable opportunity to proceed under Article 18.1, to assume the defense of such claim, such Indemnified Person may at the expense of the indemnifying Party contest, settle or consent to the entry of any judgment with respect to, or pay in full, such claim.

18.1.2 Indemnifying Party. If an Indemnifying Party is obligated to indemnify and hold any Indemnified Person harmless under this Article 18, the amount owing to the Indemnified Person shall be the amount of such Indemnified Person's actual Loss, net of any insurance or other recovery.

18.1.3 Indemnity Procedures. Promptly after receipt by an Indemnified Person of any claim or notice of the commencement of any action or administrative or legal proceeding or investigation as to which the indemnity provided for in Article 18.1 may apply, the Indemnified Person shall notify the Indemnifying Party of such fact. Any failure of or delay in such notification shall not affect a Party's indemnification obligation unless such failure or delay is materially prejudicial to the indemnifying Party.

The Indemnifying Party shall have the right to assume the defense thereof with counsel designated by such Indemnifying Party and reasonably satisfactory to the Indemnified Person. If the defendants in any such action include one or more Indemnified Persons and the Indemnifying Party and if the Indemnified Person reasonably

concludes that there may be legal defenses available to it and/or other Indemnified Persons which are different from or additional to those available to the Indemnifying Party, the Indemnified Person shall have the right to select separate counsel to assert such legal defenses and to otherwise participate in the defense of such action on its own behalf. In such instances, the Indemnifying Party shall only be required to pay the fees and expenses of one additional attorney to represent an Indemnified Person or Indemnified Persons having such differing or additional legal defenses.

The Indemnified Person shall be entitled, at its expense, to participate in any such action, suit or proceeding, the defense of which has been assumed by the Indemnifying Party.

Notwithstanding the foregoing, the Indemnifying Party (i) shall not be entitled to assume and control the defense of any such action, suit or proceedings if and to the extent that, in the opinion of the Indemnified Person and its counsel, such action, suit or proceeding involves the potential imposition of criminal liability on the Indemnified Person, or there exists a conflict or adversity of interest between the Indemnified Person and the Indemnifying Party, in such event the Indemnifying Party shall pay the reasonable expenses of the Indemnified Person, and (ii) shall not settle or consent to the entry of any judgment in any action, suit or proceeding without the consent of the Indemnified Person, which shall not be reasonably withheld, conditioned or delayed.

18.2 Consequential Damages. Other than the Liquidated Damages heretofore described, in no event shall either Party be liable under any provision of this LGIA for any losses, damages, costs or expenses for any special, indirect, incidental, consequential, or punitive damages, including but not limited to loss of profit or revenue, loss of the use of equipment, cost of capital, cost of temporary equipment or services, whether based in whole or in part in contract, in tort, including negligence, strict liability, or any other theory of liability; provided, however, that damages for which a Party may be liable to the other Party under another agreement will not be considered to be special, indirect, incidental, or consequential damages hereunder.

18.3 Insurance. Each party shall, at its own expense, maintain in force throughout the period of this LGIA, and until released by the other Party, the following minimum insurance coverages, with insurers authorized to do business in the state where the Point of Interconnection is located:

- 18.3.1** Employers' Liability and Workers' Compensation Insurance providing statutory benefits in accordance with the laws and regulations of the state in which the Point of Interconnection is located.
- 18.3.2** Commercial General Liability Insurance including premises and operations, personal injury, broad form property damage, broad form blanket contractual liability coverage (including coverage for the contractual indemnification) products and completed operations coverage, coverage for explosion, collapse and underground hazards, independent contractors coverage, coverage for pollution to the extent normally available and punitive damages to the extent normally available and a cross liability endorsement, with minimum limits of One Million Dollars (\$1,000,000) per occurrence/One Million Dollars (\$1,000,000) aggregate combined single limit for personal injury, bodily injury, including death and property damage.
- 18.3.3** Comprehensive Automobile Liability Insurance for coverage of owned and non-owned and hired vehicles, trailers or semi-trailers designed for travel on public roads, with a minimum, combined single limit of One Million Dollars (\$1,000,000) per occurrence for bodily injury, including death, and property damage.
- 18.3.4** Excess Public Liability Insurance over and above the Employers' Liability Commercial General Liability and Comprehensive Automobile Liability Insurance coverage, with a minimum combined single limit of Twenty Million Dollars (\$20,000,000) per occurrence/Twenty Million Dollars (\$20,000,000) aggregate.
- 18.3.5** The Commercial General Liability Insurance, Comprehensive Automobile Insurance and Excess Public Liability Insurance policies shall name the other Party, its parent, associated and Affiliate companies and their respective directors, officers, agents, servants and employees ("Other Party Group") as additional insured. All policies shall contain provisions whereby the insurers waive all rights of subrogation in accordance with the provisions of this LGIA against the Other Party Group and provide thirty (30) days advance written notice to the Other Party Group prior to anniversary date of cancellation or any material change in coverage or condition.

- 18.3.6** The Commercial General Liability Insurance, Comprehensive Automobile Liability Insurance and Excess Public Liability Insurance policies shall contain provisions that specify that the policies are primary and shall apply to such extent without consideration for other policies separately carried and shall state that each insured is provided coverage as though a separate policy had been issued to each, except the insurer's liability shall not be increased beyond the amount for which the insurer would have been liable had only one insured been covered. Each Party shall be responsible for its respective deductibles or retentions.
- 18.3.7** The Commercial General Liability Insurance, Comprehensive Automobile Liability Insurance and Excess Public Liability Insurance policies, if written on a Claims First Made Basis, shall be maintained in full force and effect for two (2) years after termination of this LGIA, which coverage may be in the form of tail coverage or extended reporting period coverage if agreed by the Parties.
- 18.3.8** The requirements contained herein as to the types and limits of all insurance to be maintained by the Parties are not intended to and shall not in any manner, limit or qualify the liabilities and obligations assumed by the Parties under this LGIA.
- 18.3.9** Within ten (10) days following execution of this LGIA, and as soon as practicable after the end of each fiscal year or at the renewal of the insurance policy and in any event within ninety (90) days thereafter, each Party shall provide certification of all insurance required in this LGIA, executed by each insurer or by an authorized representative of each insurer.
- 18.3.10** Notwithstanding the foregoing, each Party may self-insure to meet the minimum insurance requirements of Articles 18.3.2 through 18.3.8 to the extent it maintains a self-insurance program; provided that, such Party's senior secured debt is rated at investment grade or better by Standard & Poor's and that its self-insurance program meets the minimum insurance requirements of Articles 18.3.2 through 18.3.8. For any period of time that a Party's senior secured debt is unrated by Standard & Poor's or is rated at less than investment grade by Standard & Poor's, such Party shall comply with the insurance requirements applicable to it under Articles 18.3.2 through 18.3.9. In the event that a Party is permitted to self-insure pursuant

to this article, it shall notify the other Party that it meets the requirements to self-insure and that its self-insurance program meets the minimum insurance requirements in a manner consistent with that specified in Article 18.3.9.

18.3.11 The Parties agree to report to each other in writing as soon as practical all accidents or occurrences resulting in injuries to any person, including death, and any property damage arising out of this LGIA.

Article 19. Assignment

19.1 Assignment. This LGIA may be assigned by either Party only with the written consent of the other; provided that either Party may assign this LGIA without the consent of the other Party to any Affiliate of the assigning Party with an equal or greater credit rating and with the legal authority and operational ability to satisfy the obligations of the assigning Party under this LGIA; and provided further that Interconnection Customer shall have the right to assign this LGIA, without the consent of Transmission Provider, for collateral security purposes to aid in providing financing for the Large Generating Facility, provided that Interconnection Customer will promptly notify Transmission Provider of any such assignment. Any financing arrangement entered into by Interconnection Customer pursuant to this article will provide that prior to or upon the exercise of the secured party's, trustee's or mortgagee's assignment rights pursuant to said arrangement, the secured creditor, the trustee or mortgagee will notify Transmission Provider of the date and particulars of any such exercise of assignment right(s), including providing the Transmission Provider with proof that it meets the requirements of Articles 11.5 and 18.3. Any attempted assignment that violates this article is void and ineffective. Any assignment under this LGIA shall not relieve a Party of its obligations, nor shall a Party's obligations be enlarged, in whole or in part, by reason thereof. Where required, consent to assignment will not be unreasonably withheld, conditioned or delayed.

Article 20. Severability

20.1 Severability. If any provision in this LGIA is finally determined to be invalid, void or unenforceable by any court or other Governmental Authority having jurisdiction, such determination shall not invalidate, void or make unenforceable any other provision, agreement or covenant of this LGIA; provided that if

Interconnection Customer (or any third party, but only if such third party is not acting at the direction of Transmission Provider) seeks and obtains such a final determination with respect to any provision of the Alternate Option (Article 5.1.2), or the Negotiated Option (Article 5.1.4), then none of these provisions shall thereafter have any force or effect and the Parties' rights and obligations shall be governed solely by the Standard Option (Article 5.1.1).

Article 21. Comparability

21.1 Comparability. The Parties will comply with all applicable comparability and code of conduct laws, rules and regulations, as amended from time to time.

Article 22. Confidentiality

22.1 Confidentiality. Confidential Information shall include, without limitation, all information relating to a Party's technology, research and development, business affairs, and pricing, and any information supplied by either of the Parties to the other prior to the execution of this LGIA.

Information is Confidential Information only if it is clearly designated or marked in writing as confidential on the face of the document, or, if the information is conveyed orally or by inspection, if the Party providing the information orally informs the Party receiving the information that the information is confidential.

If requested by either Party, the other Party shall provide in writing, the basis for asserting that the information referred to in this Article 22 warrants confidential treatment, and the requesting Party may disclose such writing to the appropriate Governmental Authority. Each Party shall be responsible for the costs associated with affording confidential treatment to its information.

22.1.1 Term. During the term of this LGIA, and for a period of three (3) years after the expiration or termination of this LGIA, except as otherwise provided in this Article 22, each Party shall hold in confidence and shall not disclose to any person Confidential Information.

22.1.2 Scope. Confidential Information shall not include information that the receiving Party can demonstrate: (1) is generally available to the public other than as a result of a disclosure by the receiving Party;

(2) was in the lawful possession of the receiving Party on a non-confidential basis before receiving it from the disclosing Party; (3) was supplied to the receiving Party without restriction by a third party, who, to the knowledge of the receiving Party after due inquiry, was under no obligation to the disclosing Party to keep such information confidential; (4) was independently developed by the receiving Party without reference to Confidential Information of the disclosing Party; (5) is, or becomes, publicly known, through no wrongful act or omission of the receiving Party or Breach of this LGIA; or (6) is required, in accordance with Article 22.1.7 of the LGIA, Order of Disclosure, to be disclosed by any Governmental Authority or is otherwise required to be disclosed by law or subpoena, or is necessary in any legal proceeding establishing rights and obligations under this LGIA. Information designated as Confidential Information will no longer be deemed confidential if the Party that designated the information as confidential notifies the other Party that it no longer is confidential.

22.1.3 Release of Confidential Information. Neither Party shall release or disclose Confidential Information to any other person, except to its Affiliates (limited by the Standards of Conduct requirements), subcontractors, employees, consultants, or to parties who may be or considering providing financing to or equity participation with Interconnection Customer, or to potential purchasers or assignees of Interconnection Customer, on a need-to-know basis in connection with this LGIA, unless such person has first been advised of the confidentiality provisions of this Article 22 and has agreed to comply with such provisions. Notwithstanding the foregoing, a Party providing Confidential Information to any person shall remain primarily responsible for any release of Confidential Information in contravention of this Article 22.

22.1.4 Rights. Each Party retains all rights, title, and interest in the Confidential Information that each Party discloses to the other Party. The disclosure by each Party to the other Party of Confidential Information shall not be deemed a waiver by either Party or any other person or entity of the right to protect the Confidential Information from public disclosure.

22.1.5 No Warranties. By providing Confidential Information, neither Party makes any warranties or representations as to its accuracy or

completeness. In addition, by supplying Confidential Information, neither Party obligates itself to provide any particular information or Confidential Information to the other Party nor to enter into any further agreements or proceed with any other relationship or joint venture.

- 22.1.6 Standard of Care.** Each Party shall use at least the same standard of care to protect Confidential Information it receives as it uses to protect its own Confidential Information from unauthorized disclosure, publication or dissemination. Each Party may use Confidential Information solely to fulfill its obligations to the other Party under this LGIA or its regulatory requirements.
- 22.1.7 Order of Disclosure.** If a court or a Government Authority or entity with the right, power, and apparent authority to do so requests or requires either Party, by subpoena, oral deposition, interrogatories, requests for production of documents, administrative order, or otherwise, to disclose Confidential Information, that Party shall provide the other Party with prompt notice of such request(s) or requirement(s) so that the other Party may seek an appropriate protective order or waive compliance with the terms of this LGIA. Notwithstanding the absence of a protective order or waiver, the Party may disclose such Confidential Information which, in the opinion of its counsel, the Party is legally compelled to disclose. Each Party will use Reasonable Efforts to obtain reliable assurance that confidential treatment will be accorded any Confidential Information so furnished.
- 22.1.8 Termination of Agreement.** Upon termination of this LGIA for any reason, each Party shall, within ten (10) Calendar Days of receipt of a written request from the other Party, use Reasonable Efforts to destroy, erase, or delete (with such destruction, erasure, and deletion certified in writing to the other Party) or return to the other Party, without retaining copies thereof, any and all written or electronic Confidential Information received from the other Party.
- 22.1.9 Remedies.** The Parties agree that monetary damages would be inadequate to compensate a Party for the other Party's Breach of its obligations under this Article 22. Each Party accordingly agrees that the other Party shall be entitled to equitable relief, by way of injunction or otherwise, if the first Party Breaches or threatens to

Breach its obligations under this Article 22, which equitable relief shall be granted without bond or proof of damages, and the receiving Party shall not plead in defense that there would be an adequate remedy at law. Such remedy shall not be deemed an exclusive remedy for the Breach of this Article 22, but shall be in addition to all other remedies available at law or in equity. The Parties further acknowledge and agree that the covenants contained herein are necessary for the protection of legitimate business interests and are reasonable in scope. No Party, however, shall be liable for indirect, incidental, or consequential or punitive damages of any nature or kind resulting from or arising in connection with this Article 22.

22.1.10 Disclosure to FERC, its Staff, or a State. Notwithstanding anything in this Article 22 to the contrary, and pursuant to 18 CFR section 1b.20, if FERC or its staff, during the course of an investigation or otherwise, requests information from one of the Parties that is otherwise required to be maintained in confidence pursuant to this LGIA, the Party shall provide the requested information to FERC or its staff, within the time provided for in the request for information. In providing the information to FERC or its staff, the Party must, consistent with 18 CFR section 388.112, request that the information be treated as confidential and non-public by FERC and its staff and that the information be withheld from public disclosure. Parties are prohibited from notifying the other Party to this LGIA prior to the release of the Confidential Information to FERC or its staff. The Party shall notify the other Party to the LGIA when it is notified by FERC or its staff that a request to release Confidential Information has been received by FERC, at which time either of the Parties may respond before such information would be made public, pursuant to 18 CFR section 388.112. Requests from a state regulatory body conducting a confidential investigation shall be treated in a similar manner, consistent with the applicable state rules and regulations.

22.1.11 Subject to the exception in Article 22.1.10, any information that a Party claims is competitively sensitive, commercial or financial information under this LGIA ("Confidential Information") shall not be disclosed by the other Party to any person not employed or retained by the other Party, except to the extent disclosure is (i) required by law; (ii) reasonably deemed by the disclosing Party to be required to be disclosed in connection with a dispute between or

among the Parties, or the defense of litigation or dispute; (iii) otherwise permitted by consent of the other Party, such consent not to be unreasonably withheld; or (iv) necessary to fulfill its obligations under this LGIA or as a transmission service provider or a Control Area operator including disclosing the Confidential Information to an RTO or ISO or to a regional or national reliability organization. The Party asserting confidentiality shall notify the other Party in writing of the information it claims is confidential. Prior to any disclosures of the other Party's Confidential Information under this subparagraph, or if any third party or Governmental Authority makes any request or demand for any of the information described in this subparagraph, the disclosing Party agrees to promptly notify the other Party in writing and agrees to assert confidentiality and cooperate with the other Party in seeking to protect the Confidential Information from public disclosure by confidentiality agreement, protective order or other reasonable measures.

Article 23. Environmental Releases

23.1 Each Party shall notify the other Party, first orally and then in writing, of the release of any Hazardous Substances, any asbestos or lead abatement activities, or any type of remediation activities related to the Large Generating Facility or the Interconnection Facilities, each of which may reasonably be expected to affect the other Party. The notifying Party shall: (i) provide the notice as soon as practicable, provided such Party makes a good faith effort to provide the notice no later than twenty-four hours after such Party becomes aware of the occurrence; and (ii) promptly furnish to the other Party copies of any publicly available reports filed with any Governmental Authorities addressing such events.

Article 24. Information Requirements

24.1 Information Acquisition. Transmission Provider and Interconnection Customer shall submit specific information regarding the electrical characteristics of their respective facilities to each other as described below and in accordance with Applicable Reliability Standards.

24.2 Information Submission by Transmission Provider. The initial information submission by Transmission Provider shall occur no later than one hundred eighty (180) Calendar Days prior to Trial Operation and shall include Transmission System information necessary to allow Interconnection Customer to select equipment and meet any system protection and stability requirements, unless otherwise agreed to by the Parties. On a monthly basis Transmission Provider shall provide Interconnection Customer a status report on the construction and installation of Transmission Provider's Interconnection Facilities and Network Upgrades, including, but not limited to, the following information: (1) progress to date; (2) a description of the activities since the last report" (3) a description of the action items for the next period; and (4) the delivery status of equipment ordered.

24.3 Updated Information Submission by Interconnection Customer. The updated information submission by Interconnection Customer, including manufacturer information, shall occur no later than one hundred eighty (180) Calendar Days prior to the Trial Operation. Interconnection Customer shall submit a completed copy of the Large Generating Facility data requirements contained in Appendix 1 to the LGIP. It shall also include any additional information provided to Transmission Provider for the Feasibility and Facilities Study. Information in this submission shall be the most current Large Generating Facility design or expected performance data. Information submitted for stability models shall be compatible with Transmission Provider standard models. If there is no compatible model, Interconnection Customer will work with a consultant mutually agreed to by the Parties to develop and supply a standard model and associated information.

If Interconnection Customer's data is materially different from what was originally provided to Transmission Provider pursuant to the Interconnection Study Agreement between Transmission Provider and Interconnection Customer, then Transmission Provider will conduct appropriate studies to determine the impact on Transmission Provider Transmission System based on the actual data submitted pursuant to this Article 24.3. The Interconnection Customer shall not begin Trial Operation until such studies are completed.

24.4 Information Supplementation. Prior to the Operation Date, the Parties shall supplement their information submissions described above in this Article 24 with any and all "as-built" Large Generating Facility information or "as-tested" performance information that differs from the initial submissions or, alternatively, written confirmation that no such differences exist. The Interconnection Customer shall conduct tests on the Large Generating Facility as required by Good Utility

Practice such as an open circuit "step voltage" test on the Large Generating Facility to verify proper operation of the Large Generating Facility's automatic voltage regulator.

Unless otherwise agreed, the test conditions shall include: (1) Large Generating Facility at synchronous speed; (2) automatic voltage regulator on and in voltage control mode; and (3) a five percent change in Large Generating Facility terminal voltage initiated by a change in the voltage regulators reference voltage. Interconnection Customer shall provide validated test recordings showing the responses of Large Generating Facility terminal and field voltages. In the event that direct recordings of these voltages is impractical, recordings of other voltages or currents that mirror the response of the Large Generating Facility's terminal or field voltage are acceptable if information necessary to translate these alternate quantities to actual Large Generating Facility terminal or field voltages is provided. Large Generating Facility testing shall be conducted and results provided to Transmission Provider for each individual generating unit in a station.

Subsequent to the Operation Date, Interconnection Customer shall provide Transmission Provider any information changes due to equipment replacement, repair, or adjustment. Transmission Provider shall provide Interconnection Customer any information changes due to equipment replacement, repair or adjustment in the directly connected substation or any adjacent Transmission Provider-owned substation that may affect Interconnection Customer's Interconnection Facilities equipment ratings, protection or operating requirements. The Parties shall provide such information no later than thirty (30) Calendar Days after the date of the equipment replacement, repair or adjustment.

Article 25. Information Access and Audit Rights

25.1 Information Access. Each Party (the "disclosing Party") shall make available to the other Party information that is in the possession of the disclosing Party and is necessary in order for the other Party to: (i) verify the costs incurred by the disclosing Party for which the other Party is responsible under this LGIA; and (ii) carry out its obligations and responsibilities under this LGIA. The Parties shall not use such information for purposes other than those set forth in this Article 25.1 and to enforce their rights under this LGIA.

25.2 Reporting of Non-Force Majeure Events. Each Party (the "notifying Party") shall notify the other Party when the notifying Party becomes aware of its inability to comply with the provisions of this LGIA for a reason other than a Force

Majeure event. The Parties agree to cooperate with each other and provide necessary information regarding such inability to comply, including the date, duration, reason for the inability to comply, and corrective actions taken or planned to be taken with respect to such inability to comply. Notwithstanding the foregoing, notification, cooperation or information provided under this article shall not entitle the Party receiving such notification to allege a cause for anticipatory breach of this LGIA.

25.3 Audit Rights. Subject to the requirements of confidentiality under Article 22 of this LGIA, each Party shall have the right, during normal business hours, and upon prior reasonable notice to the other Party, to audit at its own expense the other Party's accounts and records pertaining to either Party's performance or either Party's satisfaction of obligations under this LGIA. Such audit rights shall include audits of the other Party's costs, calculation of invoiced amounts, Transmission Provider's efforts to allocate responsibility for the provision of reactive support to the Transmission System, Transmission Provider's efforts to allocate responsibility for interruption or reduction of generation on the Transmission System, and each Party's actions in an Emergency Condition. Any audit authorized by this article shall be performed at the offices where such accounts and records are maintained and shall be limited to those portions of such accounts and records that relate to each Party's performance and satisfaction of obligations under this LGIA. Each Party shall keep such accounts and records for a period equivalent to the audit rights periods described in Article 25.4.

25.4 Audit Rights Periods.

25.4.1 Audit Rights Period for Construction-Related Accounts and Records. Accounts and records related to the design, engineering, procurement, and construction of Transmission Provider's Interconnection Facilities and Network Upgrades shall be subject to audit for a period of twenty-four months following Transmission Provider's issuance of a final invoice in accordance with Article 12.2.

25.4.2 Audit Rights Period for All Other Accounts and Records. Accounts and records related to either Party's performance or satisfaction of all obligations under this LGIA other than those described in Article 25.4.1 shall be subject to audit as follows: (i) for an audit relating to cost obligations, the applicable audit rights period shall be twenty-four months after the auditing Party's receipt of an invoice giving rise to such cost obligations; and (ii) for an audit

relating to all other obligations, the applicable audit rights period shall be twenty-four months after the event for which the audit is sought.

25.5 Audit Results. If an audit by a Party determines that an overpayment or an underpayment has occurred, a notice of such overpayment or underpayment shall be given to the other Party together with those records from the audit which support such determination.

Article 26. Subcontractors

26.1 General. Nothing in this LGIA shall prevent a Party from utilizing the services of any subcontractor as it deems appropriate to perform its obligations under this LGIA; provided, however, that each Party shall require its subcontractors to comply with all applicable terms and conditions of this LGIA in providing such services and each Party shall remain primarily liable to the other Party for the performance of such subcontractor.

26.2 Responsibility of Principal. The creation of any subcontract relationship shall not relieve the hiring Party of any of its obligations under this LGIA. The hiring Party shall be fully responsible to the other Party for the acts or omissions of any subcontractor the hiring Party hires as if no subcontract had been made; provided, however, that in no event shall Transmission Provider be liable for the actions or inactions of Interconnection Customer or its subcontractors with respect to obligations of Interconnection Customer under Article 5 of this LGIA. Any applicable obligation imposed by this LGIA upon the hiring Party shall be equally binding upon, and shall be construed as having application to, any subcontractor of such Party.

26.3 No Limitation by Insurance. The obligations under this Article 26 will not be limited in any way by any limitation of subcontractor's insurance.

Article 27. Disputes

27.1 Submission. In the event either Party has a dispute, or asserts a claim, that arises out of or in connection with this LGIA or its performance, such Party (the "disputing Party") shall provide the other Party with written notice of the dispute or claim ("Notice of Dispute"). Such dispute or claim shall be referred to a

designated senior representative of each Party for resolution on an informal basis as promptly as practicable after receipt of the Notice of Dispute by the other Party.

In the event the designated representatives are unable to resolve the claim or dispute through unassisted or assisted negotiations within thirty (30) Calendar Days of the other Party's receipt of the Notice of Dispute, such claim or dispute may, upon mutual agreement of the Parties, be submitted to arbitration and resolved in accordance with the arbitration procedures set forth below. In the event the Parties do not agree to submit such claim or dispute to arbitration, each Party may exercise whatever rights and remedies it may have in equity or at law consistent with the terms of this LGIA.

27.2 External Arbitration Procedures. Any arbitration initiated under this LGIA shall be conducted before a single neutral arbitrator appointed by the Parties. If the Parties fail to agree upon a single arbitrator within ten (10) Calendar Days of the submission of the dispute to arbitration, each Party shall choose one arbitrator who shall sit on a three-member arbitration panel. The two arbitrators so chosen shall within twenty (20) Calendar Days select a third arbitrator to chair the arbitration panel. In either case, the arbitrators shall be knowledgeable in electric utility matters, including electric transmission and bulk power issues, and shall not have any current or past substantial business or financial relationships with any party to the arbitration (except prior arbitration). The arbitrator(s) shall provide each of the Parties an opportunity to be heard and, except as otherwise provided herein, shall conduct the arbitration in accordance with the Commercial Arbitration Rules of the American Arbitration Association ("Arbitration Rules") and any applicable FERC regulations or RTO rules; provided, however, in the event of a conflict between the Arbitration Rules and the terms of this Article 27, the terms of this Article 27 shall prevail.

27.3 Arbitration Decisions. Unless otherwise agreed by the Parties, the arbitrator(s) shall render a decision within ninety (90) Calendar Days of appointment and shall notify the Parties in writing of such decision and the reasons therefor. The arbitrator(s) shall be authorized only to interpret and apply the provisions of this LGIA and shall have no power to modify or change any provision of this Agreement in any manner. The decision of the arbitrator(s) shall be final and binding upon the Parties, and judgment on the award may be entered in any court having jurisdiction. The decision of the arbitrator(s) may be appealed solely on the grounds that the conduct of the arbitrator(s), or the decision itself, violated the standards set forth in the Federal Arbitration Act or the Administrative Dispute Resolution Act. The final decision of the arbitrator must also be filed with FERC if it affects jurisdictional rates, terms and conditions of service, Interconnection Facilities, or Network Upgrades.

27.4 Costs. Each Party shall be responsible for its own costs incurred during the arbitration process and for the following costs, if applicable: (1) the cost of the arbitrator chosen by the Party to sit on the three member panel and one half of the cost of the third arbitrator chosen; or (2) one half the cost of the single arbitrator jointly chosen by the Parties.

Article 28. Representations, Warranties, and Covenants

28.1 General. Each Party makes the following representations, warranties and covenants:

28.1.1 Good Standing. Such Party is duly organized, validly existing and in good standing under the laws of the state in which it is organized, formed, or incorporated, as applicable; that it is qualified to do business in the state or states in which the Large Generating Facility, Interconnection Facilities and Network Upgrades owned by such Party, as applicable, are located; and that it has the corporate power and authority to own its properties, to carry on its business as now being conducted and to enter into this LGIA and carry out the transactions contemplated hereby and perform and carry out all covenants and obligations on its part to be performed under and pursuant to this LGIA.

28.1.2 Authority. Such Party has the right, power and authority to enter into this LGIA, to become a party hereto and to perform its obligations hereunder. This LGIA is a legal, valid and binding obligation of such Party, enforceable against such Party in accordance with its terms, except as the enforceability thereof may be limited by applicable bankruptcy, insolvency, reorganization or other similar laws affecting creditors' rights generally and by general equitable principles (regardless of whether enforceability is sought in a proceeding in equity or at law).

28.1.3 No Conflict. The execution, delivery and performance of this LGIA does not violate or conflict with the organizational or formation documents, or bylaws or operating agreement, of such Party, or any judgment, license, permit, order, material agreement or instrument applicable to or binding upon such Party or any of its assets.

28.1.4 Consent and Approval. Such Party has sought or obtained, or, in accordance with this LGIA will seek or obtain, each consent, approval, authorization, order, or acceptance by any Governmental Authority in connection with the execution, delivery and performance of this LGIA, and it will provide to any Governmental Authority notice of any actions under this LGIA that are required by Applicable Laws and Regulations.

Article 29. Joint Operating Committee

29.1 Joint Operating Committee. Except in the case of ISOs and RTOs, Transmission Provider shall constitute a Joint Operating Committee to coordinate operating and technical considerations of Interconnection Service. At least six (6) months prior to the expected Initial Synchronization Date, Interconnection Customer and Transmission Provider shall each appoint one representative and one alternate to the Joint Operating Committee. Each Interconnection Customer shall notify Transmission Provider of its appointment in writing. Such appointments may be changed at any time by similar notice. The Joint Operating Committee shall meet as necessary, but not less than once each calendar year, to carry out the duties set forth herein. The Joint Operating Committee shall hold a meeting at the request of either Party, at a time and place agreed upon by the representatives. The Joint Operating Committee shall perform all of its duties consistent with the provisions of this LGIA. Each Party shall cooperate in providing to the Joint Operating Committee all information required in the performance of the Joint Operating Committee's duties. All decisions and agreements, if any, made by the Joint Operating Committee, shall be evidenced in writing. The duties of the Joint Operating Committee shall include the following:

- 29.1.1** Establish data requirements and operating record requirements.
- 29.1.2** Review the requirements, standards, and procedures for data acquisition equipment, protective equipment, and any other equipment or software.
- 29.1.3** Annually review the one (1) year forecast of maintenance and planned outage schedules of Transmission Provider's and Interconnection Customer's facilities at the Point of Interconnection.
- 29.1.4** Coordinate the scheduling of maintenance and planned outages on

the Interconnection Facilities, the Large Generating Facility and other facilities that impact the normal operation of the interconnection of the Large Generating Facility to the Transmission System.

- 29.1.5** Ensure that information is being provided by each Party regarding equipment availability.
- 29.1.6** Perform such other duties as may be conferred upon it by mutual agreement of the Parties.

Article 30. Miscellaneous

- 30.1 Binding Effect.** This LGIA and the rights and obligations hereof, shall be binding upon and shall inure to the benefit of the successors and assigns of the Parties hereto.
- 30.2 Conflicts.** In the event of a conflict between the body of this LGIA and any attachment, appendices or exhibits hereto, the terms and provisions of the body of this LGIA shall prevail and be deemed the final intent of the Parties.
- 30.3 Rules of Interpretation.** This LGIA, unless a clear contrary intention appears, shall be construed and interpreted as follows: (1) the singular number includes the plural number and vice versa; (2) reference to any person includes such person's successors and assigns but, in the case of a Party, only if such successors and assigns are permitted by this LGIA, and reference to a person in a particular capacity excludes such person in any other capacity or individually; (3) reference to any agreement (including this LGIA), document, instrument or tariff means such agreement, document, instrument, or tariff as amended or modified and in effect from time to time in accordance with the terms thereof and, if applicable, the terms hereof; (4) reference to any Applicable Laws and Regulations means such Applicable Laws and Regulations as amended, modified, codified, or reenacted, in whole or in part, and in effect from time to time, including, if applicable, rules and regulations promulgated thereunder; (5) unless expressly stated otherwise, reference to any Article, Section or Appendix means such Article of this LGIA or such Appendix to this LGIA, or such Section to the LGIP or such Appendix to the LGIP, as the case may be; (6) "hereunder", "hereof", "herein", "hereto" and words of similar import shall be deemed references to this LGIA as a whole and not to any particular Article or other provision hereof or thereof; (7) "including" (and with correlative meaning "include") means including without limiting the

generality of any description preceding such term; and (8) relative to the determination of any period of time, "from" means "from and including", "to" means "to but excluding" and "through" means "through and including".

30.4 Entire Agreement. This LGIA, including all Appendices and Schedules attached hereto, constitutes the entire agreement between the Parties with reference to the subject matter hereof, and supersedes all prior and contemporaneous understandings or agreements, oral or written, between the Parties with respect to the subject matter of this LGIA. There are no other agreements, representations, warranties, or covenants which constitute any part of the consideration for, or any condition to, either Party's compliance with its obligations under this LGIA.

30.5 No Third Party Beneficiaries. This LGIA is not intended to and does not create rights, remedies, or benefits of any character whatsoever in favor of any persons, corporations, associations, or entities other than the Parties, and the obligations herein assumed are solely for the use and benefit of the Parties, their successors in interest and, where permitted, their assigns.

30.6 Waiver. The failure of a Party to this LGIA to insist, on any occasion, upon strict performance of any provision of this LGIA will not be considered a waiver of any obligation, right, or duty of, or imposed upon, such Party.

Any waiver at any time by either Party of its rights with respect to this LGIA shall not be deemed a continuing waiver or a waiver with respect to any other failure to comply with any other obligation, right, duty of this LGIA. Termination or Default of this LGIA for any reason by Interconnection Customer shall not constitute a waiver of Interconnection Customer's legal rights to obtain an interconnection from Transmission Provider. Any waiver of this LGIA shall, if requested, be provided in writing.

30.7 Headings. The descriptive headings of the various Articles of this LGIA have been inserted for convenience of reference only and are of no significance in the interpretation or construction of this LGIA.

30.8 Multiple Counterparts. This LGIA may be executed in two or more counterparts, each of which is deemed an original but all constitute one and the same instrument.

30.9 Amendment. The Parties may by mutual agreement amend this LGIA by a written instrument duly executed by the Parties.

30.10 Modification by the Parties. The Parties may by mutual agreement amend the Appendices to this LGIA by a written instrument duly executed by the Parties. Such amendment shall become effective and a part of this LGIA upon satisfaction of all Applicable Laws and Regulations.

30.11 Reservation of Rights. Transmission Provider shall have the right to make a unilateral filing with FERC to modify this LGIA with respect to any rates, terms and conditions, charges, classifications of service, rule or regulation under section 205 or any other applicable provision of the Federal Power Act and FERC's rules and regulations thereunder, and Interconnection Customer shall have the right to make a unilateral filing with FERC to modify this LGIA pursuant to section 206 or any other applicable provision of the Federal Power Act and FERC's rules and regulations thereunder; provided that each Party shall have the right to protest any such filing by the other Party and to participate fully in any proceeding before FERC in which such modifications may be considered. Nothing in this LGIA shall limit the rights of the Parties or of FERC under sections 205 or 206 of the Federal Power Act and FERC's rules and regulations thereunder, except to the extent that the Parties otherwise mutually agree as provided herein.

30.12 No Partnership. This LGIA shall not be interpreted or construed to create an association, joint venture, agency relationship, or partnership between the Parties or to impose any partnership obligation or partnership liability upon either Party. Neither Party shall have any right, power or authority to enter into any agreement or undertaking for, or act on behalf of, or to act as or be an agent or representative of, or to otherwise bind, the other Party.

IN WITNESS WHEREOF, the Parties have executed this Agreement in duplicate originals, each of which shall constitute and be an original effective Agreement between the Parties.

Southwest Power Pool, Inc.

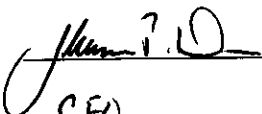
By: 
Title: CEO
Date: 11-29-04

Southwestern Public Service Company (d/b/a Xcel Energy)

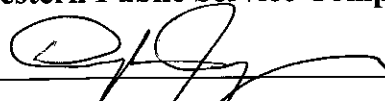
By: 
Title: Authorized Agent for SPS, VP Transmission
Date: 11/22/04

East Guymon Wind L.L.C

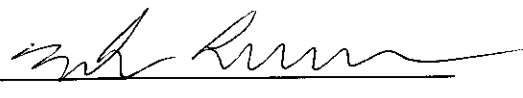
By: 
Title: Vice President of Inverergy LLC, its member
Date: 11/8/04

Appendices to Agreement

Appendix A Interconnection Facilities, Network Upgrades and Distribution Upgrades

Appendix B Milestones

Appendix C Interconnection Details

Appendix D Security Arrangements Details

Appendix E Commercial Operation Date

Appendix F Addresses for Delivery of Notices and Billings

Appendix G Requirements of Generators Relying on Newer Technologies

Appendix A To Agreement

Interconnection Facilities, Network Upgrades and Distribution Upgrades

NOTE: The facilities described in this Appendix are based on the studies conducted in response to the Interconnection Request. In the event that other interconnection customers suspend, terminate or request unexecuted filing of their LGIAs, then additional studies may be required that could result in changes to the Interconnection Facilities and the Network Upgrades and in changes to Interconnection Customer's cost obligations for those facilities.

1. Interconnection Facilities:

(a) Interconnection Customer's Interconnection Facilities to be designed, procured, constructed and installed by Interconnection Customer at the Interconnection Customer's funding and sole expense. These facilities will be owned and controlled by Interconnection Customer:

The Interconnection Customer's new wind energy project's 115/34.5 kV interconnection substation will be located approximately 2 miles east of Guymon, Oklahoma. This wind energy project will consist of 100 General Electric (GE) wind turbines with a nominal output of 1.5 MW each, for a limited output of 150 MW.

The Interconnection Customer's Interconnection Facilities will be comprised of:

- five (5) or more 34.5 kV underground cable collection circuits;
- one (1) 34.5 kV to 115 kV transformation substation with associated 34.5 kV and 115 kV switchgear. The 34.5 kV to 115 kV transformer will have a grounded wye connection on the 115 kV side;
- one (1) new 115kV line that will tie the 115/34.5kV wind farm substation to the Point-of-Interconnection and Point-of-Change-of Ownership with the Transmission Owner's Texas County Interchange; and
- all necessary relay, protection, control and communication systems in the Interconnection Customers wind farm and interconnection substation required to protect Interconnection Customer's Generating Facilities and Interconnection Facilities and coordinate with Transmission Owner's relay, protection, control and communication systems.

(b) Transmission Owner's Interconnection Facilities to be designed, procured, constructed and installed by Transmission Owner at the Interconnection Customer's funding and sole expense. These facilities will be owned and controlled by the Transmission Owner:

- Modify the 115kV bus at Texas County. Interchange will be expanded to serve the Customer's new 115 kV line;
- 115kV transmission line termination from the Interconnection Customer's dead end structure at the Point of Interconnection into the Texas County Interchange;
- Additions to the control house to accommodate the required metering, protection and control devices, and terminal cabinets and misc. equipment;
- Revenue metering equipment to be installed on the transmission line to the wind farm; and
- Communications
-RTU communication will require 4-wire data circuit between Texas County Interchange and Xcel Energy's Amarillo Service Center

Total Cost \$ 498,580

2. Network Upgrades:

(a) Stand Alone Network Upgrades to be designed, procured, constructed and installed by Transmission Owner:

There are no Stand Alone Network Upgrades.

(b) Other Network Upgrades to be designed, procured, constructed and installed by Transmission Owner:

There are no other Network Upgrades.

(c) Joint Network Upgrades

There no Joint Network Upgrades.

(d) Previous Network Upgrades

There are no Previous Network Upgrades.

(e) The cost for the Transmission Owner's Interconnection Facilities to be constructed by Interconnection Customer is estimated at \$ 0.

(f) The total cost for the Transmission Owner's Interconnection Facilities to be constructed by the Transmission Owner at the Interconnection Customer's expense is estimated at \$498,580. The Interconnection Customer is responsible for the payment of the engineering, procurement and construction of the Transmission Owner's Interconnection Facilities estimated at \$498,580 pursuant to the schedule as indicated in Appendix B, Milestones.

All cost estimates were developed using a +/- 20 percent estimate according to the LGIP. All costs are estimated in 2008 dollars with no escalation applied for the purpose of this estimate. All estimates will be trued up for actual costs and expenses for purposes of final billing under Article 12.2.

(g) The portion of the Network Upgrades that is subject to the transmission service credits described in Section 11.4 of this Agreement is estimated at \$ 0.

3. Distribution Upgrades:

There are no Transmission Owner Distribution Upgrades

4. Interconnection Service: Interconnection Customer has selected the following:

 150 MW Energy Resource Interconnection Service
 MW Network Resource Interconnection Service within Transmission Owner's Control Area
 MW Network Resource Interconnection Service to outside Transmission Owner's Control Area

5. Construction Option Selected by Interconnection Customer:

Interconnection Customer has selected the Standard Option for construction of the Transmission Owner's Interconnection Facilities and the Network Upgrades.

6. Eligible Network Customers:

Not Used

7. Permits, Licenses and Authorizations:

The Interconnection Customer is responsible to secure all Permits, Licenses and Authorizations necessary for the construction and operation of its Generating Facilities and Interconnection Facilities.

WIND FARM INTERCONNECTION

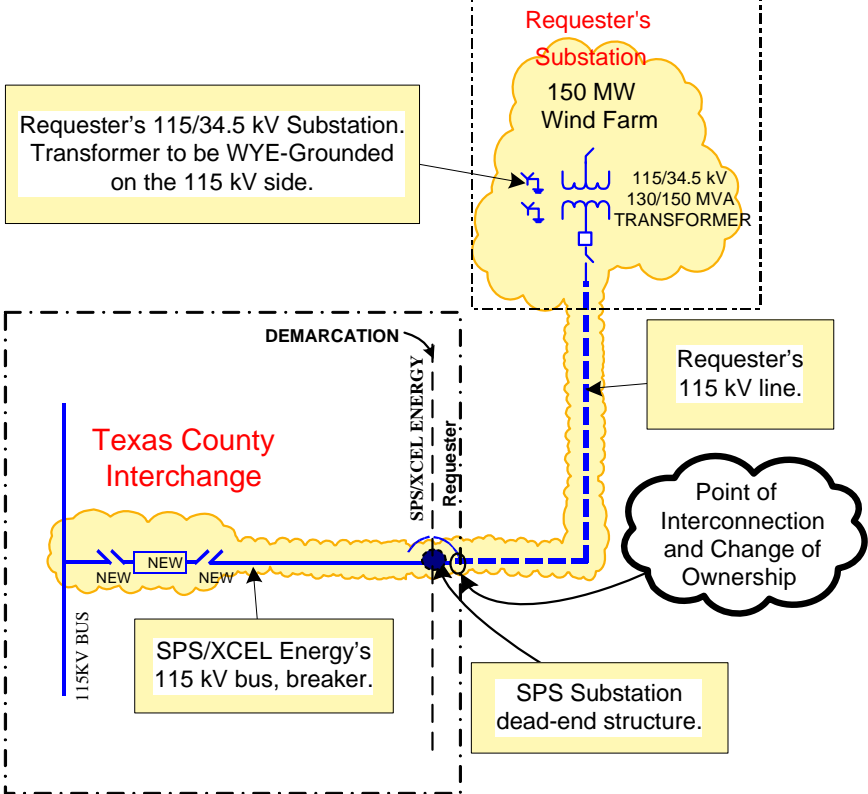
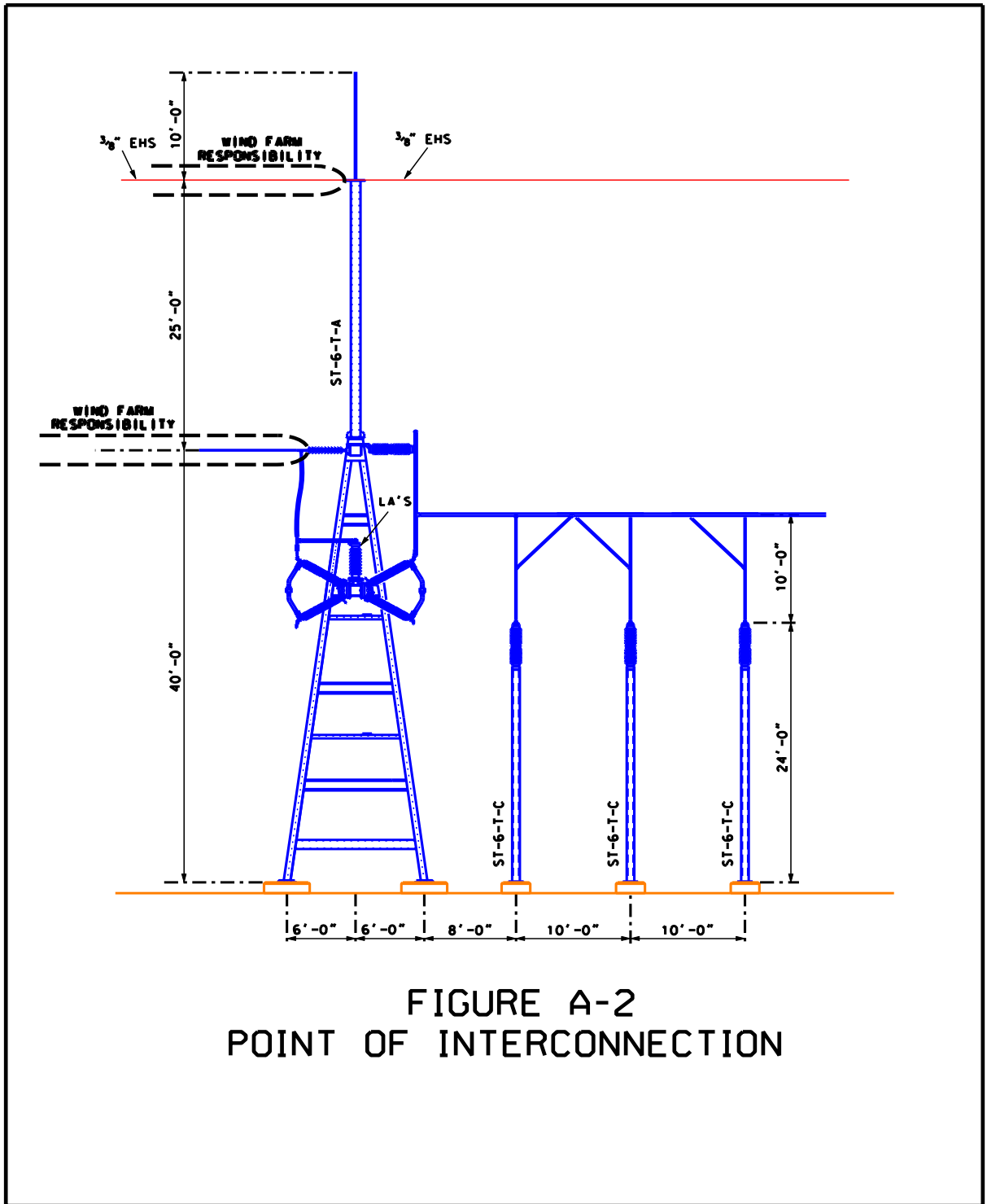

Figure A-1 Wind Farm Interconnection



**FIGURE A-2
POINT OF INTERCONNECTION**

Figure A-2 Point of Interconnection and Change of Ownership

**Appendix B
To Agreement**

Milestones – Amended August 2008

Action	Responsible Party	Completion Date
Complete Facilities Study	Transmission Provider	02/19/2004 - Completed
Suspension Notice	Interconnection Customer	02/11/2005
Unsuspending Notice	Interconnection Customer	02/08/2008
Provide authorization to proceed with design of Transmission Owner Interconnection Facilities to be constructed by Transmission Owner per Article 5.5.2	Interconnection Customer	01/09/2009
Provide payment of \$100,000 for engineering design of Transmission Owner Interconnection Facilities	Interconnection Customer	01/09/2009
Provide payment for the procurement of Transmission Owner Interconnection Facilities in the amount of \$150,000	Interconnection Customer	06/15/2009
Obtain Governmental Authorization (as necessary)	Interconnection Customer	
Provide authorization to proceed with construction of Transmission Owner Interconnection Facilities to be constructed by Transmission Owner per Article 5.6.3	Interconnection Customer	01/08/2010
Provide payment of \$248,580 for construction of Transmission Owner Interconnection Facilities to be constructed by Transmission Owner.	Interconnection Customer	01/08/2010
In-Service Date for Transmission Owner Interconnection Facilities	Transmission Owner	06/30/2010
In-Service Date & energization of Interconnection Customer's Interconnection Facilities	Interconnection Customer	08/01/2010
Initial Synchronization Date	Interconnection Customer	09/01/2010
Begin trial operation & testing per Article 6.1	Interconnection Customer & Transmission Owner	09/01/2010
Commercial operation date	Interconnection Customer	12/31/2010
Final accounting of costs incurred by Transmission Owner for construction of Transmission Owner Interconnection Facilities	Transmission Owner	To be submitted within six months of Completing Construction of the Transmission Owner Interconnection Facilities and Network Upgrades

Appendix C To Agreement

Interconnection Details

General: Transmission Provider, Transmission Owner, and Interconnection Customer agree that the Generating Facility cannot be, and is not equipped with Power System Stabilizers.

Transmission Provider, Transmission Owner, and Interconnection Customer agree that the operation of the Generating Facility with the proposed General Electric (GE) wind turbine generators with reactive power control capable of controlling the interconnection power factor shall satisfy the power factor requirements stated as follows. Over the full range of the wind farm's generating capacity, the power factor at the point of interconnection shall be within the range of 0.98 (generation absorbing VARS) to a 0.95 (generation supplying VARS) to the Transmission Owner's transmission system.

In order to accommodate possible minor changes in operating conditions, SPP, or the Transmission Operator may permit, at its sole discretion, adjustments to the specified limits.

Facility: The Interconnection Customer's Wind Energy Project is a new wind energy generation facility located approximately 3 miles east of Guymon, Oklahoma. The new wind energy generation facility will interconnect the 150 MW wind facility to the transmission on a new 115kV transmission line tied to Texas County Interchange. The new wind energy project's 115/34.5 kV interconnection substation will be located approximately 2 miles east of Guymon, Oklahoma. The 115/34.5 kV transformer will have a grounded wye connection on the 115 kV. This wind energy project will consist of 100 General Electric (GE) wind turbines with a nominal output of 1.5 MW each, for a nominal output of 150 MW.

Point of Interconnection: The Interconnection Customer's 115kV line will terminate at Transmission Owner's steel dead-end structure just inside the Texas County Interchange fence. Interconnection Customer will terminate the 115kV line with a single slack span of 795MCM ACSR conductor with 3/8" EHS static wire from the Interconnection Customer's dead-end structure to the Transmission Owner's Texas County Interchange steel dead-end structure. The line terminals will be designed to accommodate 2,000 pounds per phase conductor at maximum tension heavy-load and two shield wires designed to accommodate 2,000 pounds each at maximum tension heavy-load. The point of interconnection will be the connection between the Interconnection Customer's phase conductors terminated on their dead-end structure located just outside the Texas County Interchange fence, and the slack-span jumper. See Figure A-1, Wind Farm Interconnection and Figure A-2, Point of Interconnection in Appendix A.

Revenue Metering: At Texas County Interchange, Transmission Owner will install on the line to the Interconnection Customer's wind farm, billing meters with a 115 kV CTs for full 3 phase 4-wire metering. There will be two meters: one will be primary and the other will be back-up,

each will have full 4 quadrant metering. Metering pulses will be sent via SCADA to the Transmission Owner's Control Center in Amarillo, Texas.

Relay and Protection Scheme: On the 115kV line from Texas County Interchange to the Interconnection Customer's owned line, relaying will be step distance where a SEL 321-1 and SEL 311-C relays will be used. A SEL 279H-2 relay will be installed for line/bus conditions and sync check along with supervisory closing of the breaker. There will not be any automatic reclosing. A SEL 501-0 will be used for breaker failure.

Generator Under-frequency Response: SPP has a coordinated regional under-frequency load shedding and restoration plan. The requirements of that plan are detailed in SPP Criteria. The Interconnection Customer agrees that the under-frequency relay instantaneous trip setting shall be set not higher than the 58.5 Hz.

OPERATING GUIDELINES

SWITCHING AND TAGGING PROCEDURES

1. Definitions

- 1.1 CLEARANCE - The process of removing and holding a transmission line, section of bus or piece of equipment from service so that work may be safely performed.
- 1.2 CLEARANCE TAG - The formal registered tag in the Transmission Owner's Switching Procedures document. It is applied at the switches and disconnects through which electrical energy may be supplied to the section of line or equipment at which safety CLEARANCE is desired. It may be used with proper authority and registration at all voltage levels. A CLEARANCE TAG is NEVER used to hold circuits or equipment IN service.

2. Planned Clearance Request in the Facility Originated by Interconnection Customer

- 2.1 If the switching on the Facility requires switching of equipment owned by the Interconnection Customer and controlled by SPP or Transmission Owner, then the Interconnection Customer will send a Clearance Request to the Transmission Owner's or SPP's Transmission System operator to facilitate the switching.

3. Planned Clearance Request originated by Interconnection Customer

- 3.1 Any planned switching originated by the Interconnection Customer which requires switching of equipment controlled by SPP or Transmission Owner, will be coordinated with a Clearance Request through the Transmission Owner's transmission system operator with a minimum of 24 hours notice except in emergency situations (notices of between 24 hours and ten days may be required depending on the impact of the outage on the transmission grid). The Transmission Owner's transmission system operator will accommodate the request as soon as practicable. Personnel availability and system conditions may prevent a Clearance Request from being completed. The Interconnection Customer personnel will perform all switching and apply all CLEARANCE TAGS to equipment owned by the Interconnection Customer in the Interconnection Customer's substation. Transmission Owner personnel may observe the switching if desired.

4. Planned Clearance Request in the Interconnection Customer's Facilities originated by the Transmission Owner

- 4.1 All planned Clearance Requests on the Facility, which requires switching of equipment controlled by the Interconnection Customer and originated by SPP or Transmission Owner, will be coordinated with the Interconnection Customer's

personnel by a Clearance Request submitted by Transmission Owner personnel with a minimum of 48 hours notice except in emergency situations. The Interconnection Customer will accommodate the request as soon as practicable. All switching and application of CLEARANCE TAGS on equipment owned by Interconnection Customer, in the Interconnection Customer's Facilities, will be performed by the Interconnection Customer's personnel. Transmission Owner personnel will be allowed to observe all switching if desired. Once the Interconnection Customer's operator is assured that all devices are properly opened and tagged, the Interconnection Customer's personnel will provide CLEARANCE to the Transmission Owner's Transmission System Operator.

5. Planned Clearance Request originated by Transmission Owner

- 5.1 Interconnection Customer will be notified for informational purposes only of any planned Clearance Request on the Transmission System that do not require total isolation of the Interconnection Customer Facilities.
- 5.2 Any planned Clearance Requests that would result in the isolation of the Interconnection Customer Facilities from the Transmission System or in a reduction in interconnection capacity will be coordinated with the Interconnection Customer.

6. Unplanned Requests To Isolate Interconnection Customer Facilities By Remote Breaker Operations

- 6.1 Interconnection Customer may request the Transmission Owner's transmission system operator to isolate the Interconnection Customer Facilities from the Transmission Owner's system by remote opening breakers. The Transmission Owner's transmission system operator will accommodate the request as soon as practicable. System conditions may prevent such a request from being completed. Clearance will not be given and the Interconnection Customer's personnel must isolate the Interconnection Customer Facilities before starting work. If Clearance is required then request must be made under the procedures of Section 3.1 above.

7. Unplanned Outages

- 7.1 If an unplanned interruption occurs in either the Facility or the Transmission System, both the Transmission Owner's transmission system operator and the Interconnection Customer's personnel will provide the other with all pertinent information. This information will include, but may not be limited to:
 - 1. the devices involved,
 - 2. present status of devices in question,
 - 3. time stamps,
 - 4. cause of interruption (if available),

5. relay targets (if available),
6. any information helpful in determining cause and/or useful in the restoration process

8. **Re-energization**

Procedures for Re-energizing Interconnection Customer's Facilities after Isolation from the Transmission Owner's System

- 8.1 Interconnection Customer's personnel must request the Transmission Owner's transmission system operator to re-energize the Interconnection Customer Facilities after they have become isolated.

9. **Emergency Switching**

Emergency Switching to Isolate the Interconnection Customer's Facilities from the Transmission Owner's System

- 9.1 During emergency situations, Transmission Owner's personnel may request Interconnection Customer's personnel to disconnect the generators at the Facility or Transmission Owner may disconnect generator remotely at the point of interconnect.

10 **Communications Requirements**

10.1 Interconnection Customer's operating personnel will notify the Transmission Owner's System Operator of the following:

- Prior to synchronization of when the Facility commences operation;
- Prior to the Facility ceasing operations;
- As soon as possible after an unplanned separation of all generators;
- For Clearance Requests for Interconnection Customer's equipment requiring switching on the Transmission Owner's system; and
- When abnormal system conditions are affecting the operation of the Interconnection Customer Facilities.

10.3 The Transmission Owner's System Operator will notify Interconnection Customer's operating personnel:

- When conditions may prevent generator synchronization;
- When conditions may require generator separation;
- On a requirement for generator separation;
- On the requirement for redispatch during a System Emergency; and
- For Clearance Request for Transmission Owner's operated equipment requiring switching on the Interconnection Customer's Interconnection Facilities.

10.4 Interconnection Customer's operating personnel will also be required to provide

hourly meter readings (MWH and MVar) to the Transmission Owner's System Operator in the event of a telemetry failure from the Interconnection Facilities. This will occur at least once per day before 9:00 a.m. Central time.

10.5 It is also anticipated that the Transmission Owner's System Operator, SPP and Interconnection Customer's operating personnel will communicate, beyond the notices as listed above, as necessary and appropriate, in accordance with Good Utility Practice, to provide reliable and efficient operation of both the Transmission Owner's system and the Interconnection Customer's Facilities.

Appendix D To Agreement

Security Arrangements Details

Infrastructure security of Transmission System equipment and operations and control hardware and software is essential to ensure day-to-day Transmission System reliability and operational security. FERC will expect all Transmission Providers, market participants, and Interconnection Customers interconnected to the Transmission System to comply with the recommendations offered by the President's Critical Infrastructure Protection Board and, eventually, best practice recommendations from the electric reliability authority. All public utilities will be expected to meet basic standards for system infrastructure and operational security, including physical, operational, and cyber-security practices.

The Parties will cooperate reasonably to comply with the recommendations described in paragraph 1 and to implement the applicable standards. The following communications schematic diagram for the project including the Interconnection Customer, Transmission Provider (Southwest Power Pool, Inc.) and Transmission Owner (Southwestern Public Service) is provided to assist the Parties in meeting these standards.

Communications Schematic Diagram

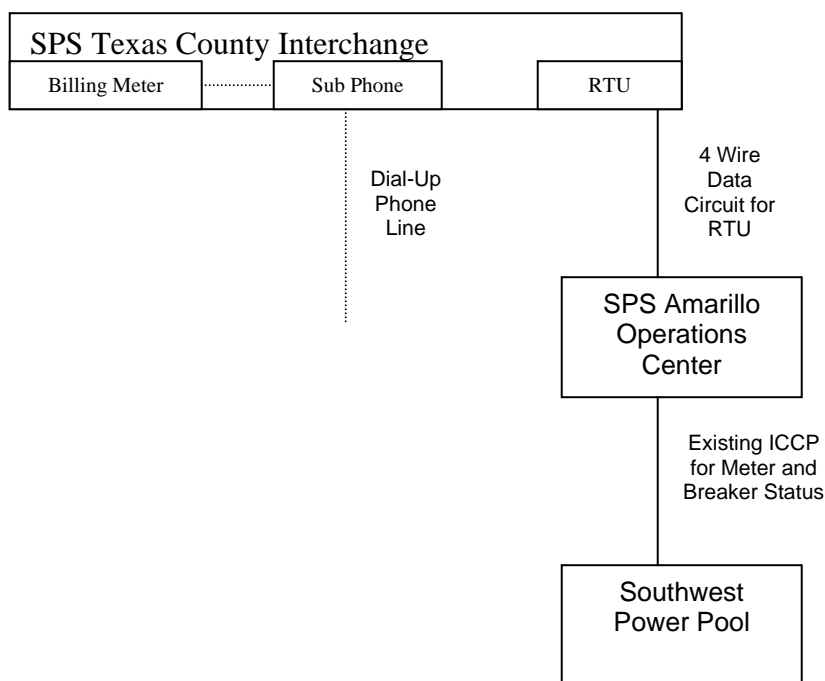

**Appendix E
To Agreement**

Commercial Operation Date

This Appendix E is a part of the Agreement between Transmission Provider, Transmission Owner and Interconnection Customer.

[Date]

Carl Monroe, Executive Vice President and Chief Operating Officer
Southwest Power Pool, Inc.
415 N. McKinley, Suite 140
Little Rock, AR 72205
Phone: 501-614-3200
Facsimile: 501-664-9553

Transmission Account Representative
Xcel Energy Services Inc.
6086 W. 48th St.
Amarillo, TX 79109

Re: East Guymon Wind Generating Facility

Dear _____:

On **[Date]** East Guymon Wind, LLC has completed Trial Operation of the Generating facility referenced in the Large Generation Interconnection Agreement signed on _____ between East Guymon Wind, LLC, Southwestern Public Service Company, and Southwest Power Pool, Inc. This letter confirms that East Guymon Wind, LLC commenced Commercial Operation of the referenced Generating Facility, effective as of **[Date plus one day]**.

Thank you.

[Signature]

Project Manager
East Guymon Wind, LLC
c/o Edison Mission Energy
18101 Von Karman Ave., Suite 1700
Irvine, CA 92612

**Appendix F
To Agreement**

Addresses for Delivery of Notices and Billings

Notices:

Transmission Provider:

Carl Monroe, Executive Vice President and Chief Operating Officer
Southwest Power Pool, Inc.
415 N. McKinley, Suite 140
Little Rock, AR 72205-3020

Transmission Owner:

Transmission Account Representative
Xcel Energy Services Inc.
6086 W. 48th St.
Amarillo, TX 79109

Interconnection Customer:

East Guymon Project Manager
East Guymon Wind LLC
c/o Edison Mission Energy
18101 Von Karman Ave., Suite 1700
Irvine, CA 92612

Billings and Payments: [Specify addresses for construction invoices, O&M invoices and settlement of ancillary services]

Transmission Provider:

Tony Alexander, Supervisor of Tariff Accounting
Southwest Power Pool, Inc.
415 N. McKinley, Suite 140
Little Rock, AR 72205-3020

Transmission Owner:

Transmission Account Representative
Xcel Energy Services Inc.
6086 W. 48th St.
Amarillo, TX 79109

Interconnection Customer:

Project Manager
East Guymon Wind LLC
c/o Edison Mission Energy
18101 Von Karman Ave., Suite 1700
Irvine, CA 92612

Alternative Forms of Delivery of Notices (telephone, facsimile or email):

Transmission Provider:

Carl Monroe, Executive Vice President and Chief Operating Officer
Southwest Power Pool, Inc.
415 N. McKinley, Suite 140
Little Rock, AR 72205
Phone: 501-614-3200
Facsimile: 501-664-9553

Transmission Owner:

Transmission Account Representative
Xcel Energy Services Inc.
6086 W. 48th St.
Amarillo, TX 79109
Phone: 806-640-6302
Facsimile: 806-457-6460

Interconnection Customer:

Project Manager
East Guymon Wind LLC

c/o Edison Mission Energy
18101 Von Karman Ave., Suite 1700
Irvine, CA 92612
Phone: 949-798-7407
Facsimile: 949-225-7228
ggriffin@edisonmission.com

Operational Communications:

Transmission Provider:

Lanny Nickell, Vice President, Operations
Southwest Power Pool, Inc.
415 N. McKinley, Suite 140
Little Rock, AR 72205
Phone: 501-614-3232
Facsimile: 501-664-9553

Transmission Owner:

SPS Transmission Operator
SPS Amarillo Operations Center
6086 W. 48th Street
Amarillo, TX 79109
Phone: 806-457-6343
Facsimile: 806-457-6349

Interconnection Customer:

Project Manager
East Guymon Wind LLC
c/o Edison Mission Energy
18101 Von Karman Ave., Suite 1700
Irvine, CA 92612
Phone: 949-798-7407
Facsimile: 949-225-7228
ggriffin@edisonmission.com

**Appendix G
To Agreement**

Requirements of Generators Relying on Newer Technologies

EXHIBIT II

Appendix A To Agreement

Interconnection Facilities, Network Upgrades and Distribution Upgrades

NOTE: The facilities described in this Appendix are based on the studies conducted in response to the Interconnection Request. In the event that other interconnection customers suspend, terminate or request unexecuted filing of their LGIAs, then additional studies may be required that could result in changes to the Interconnection Facilities and the Network Upgrades and in changes to Interconnection Customer's cost obligations for those facilities.

1. Interconnection Facilities:

(a) Interconnection Customer's Interconnection Facilities to be designed, procured, constructed and installed by Interconnection Customer at the Interconnection Customer's funding and sole expense. These facilities will be owned and controlled by Interconnection Customer:

The Interconnection Customer's new wind energy project's 115/34.5 kV interconnection substation will be located approximately 2 miles east of Guymon, Oklahoma. This wind energy project will consist of 100 General Electric (GE) wind turbines with a nominal output of 1.5 MW each, for a limited output of 150 MW.

The Interconnection Customer's Interconnection Facilities will be comprised of:

- five (5) or more 34.5 kV underground cable collection circuits;
- one (1) 34.5 kV to 115 kV transformation substation with associated 34.5 kV and 115 kV switchgear. The 34.5 kV to 115 kV transformer will have a grounded wye connection on the 115 kV side;
- one (1) new 115kV line that will tie the 115/34.5kV wind farm substation to the Point-of-Interconnection and Point-of-Change-of Ownership with the Transmission Owner's Texas County Interchange; and
- all necessary relay, protection, control and communication systems in the Interconnection Customers wind farm and interconnection substation required to protect Interconnection Customer's Generating Facilities and Interconnection Facilities and coordinate with Transmission Owner's relay, protection, control and communication systems.

(b) Transmission Owner's Interconnection Facilities to be designed, procured, constructed and installed by Transmission Owner at the Interconnection Customer's funding and sole expense. These facilities will be owned and controlled by the Transmission Owner:

- Modify the 115kV bus at Texas County. Interchange will be expanded to serve the Customer's new 115 kV line;
- 115kV transmission line termination from the Interconnection Customer's dead end structure at the Point of Interconnection into the Texas County Interchange;

- Additions to the control house to accommodate the required metering, protection and control devices, and terminal cabinets and misc. equipment;
- Revenue metering equipment to be installed on the transmission line to the wind farm; and
- Communications
 - RTU communication will require 4-wire data circuit between Texas County Interchange and Xcel Energy's Amarillo Service Center

Total Cost \$ 498,580

2. Network Upgrades:

(a) Stand Alone Network Upgrades to be designed, procured, constructed and installed by Transmission Owner:

There are no Stand Alone Network Upgrades.

(b) Other Network Upgrades to be designed, procured, constructed and installed by Transmission Owner:

There are no other Network Upgrades.

(c) Joint Network Upgrades

There no Joint Network Upgrades.

(d) Previous Network Upgrades

There are no Previous Network Upgrades.

(e) The cost for the Transmission Owner's Interconnection Facilities to be constructed by Interconnection Customer is estimated at \$ 0.

(f) The total cost for the Transmission Owner's Interconnection Facilities to be constructed by the Transmission Owner at the Interconnection Customer's expense is estimated at \$498,580. The Interconnection Customer is responsible for the payment of the engineering, procurement and construction of the Transmission Owner's Interconnection Facilities estimated at \$498,580 pursuant to the schedule as indicated in Appendix B, Milestones.

All cost estimates were developed using a +/- 20 percent estimate according to the LGIP. All costs are estimated in 2008 dollars with no escalation applied for the purpose of this estimate. All estimates will be trued up for actual costs and expenses for purposes of final billing under Article 12.2.

(g) The portion of the Network Upgrades that is subject to the transmission service credits described in Section 11.4 of this Agreement is estimated at \$ 0.

3. Distribution Upgrades:

There are no Transmission Owner Distribution Upgrades

4. Interconnection Service: Interconnection Customer has selected the following:

150 MW Energy Resource Interconnection Service

MW Network Resource Interconnection Service within Transmission Owner's Control Area

MW Network Resource Interconnection Service to outside Transmission Owner's Control Area

5. Construction Option Selected by Interconnection Customer:

Interconnection Customer has selected the Standard Option for construction of the Transmission Owner's Interconnection Facilities and the Network Upgrades.

6. Eligible Network Customers:

Not Used

7. Permits, Licenses and Authorizations:

The Interconnection Customer is responsible to secure all Permits, Licenses and Authorizations necessary for the construction and operation of its Generating Facilities and Interconnection Facilities.

WIND FARM INTERCONNECTION

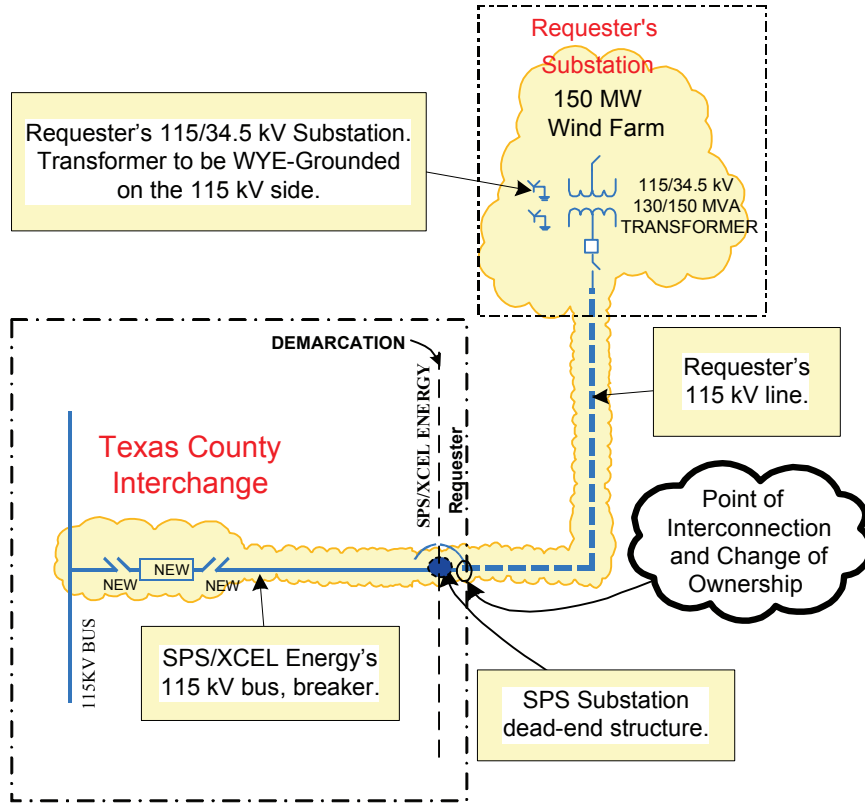
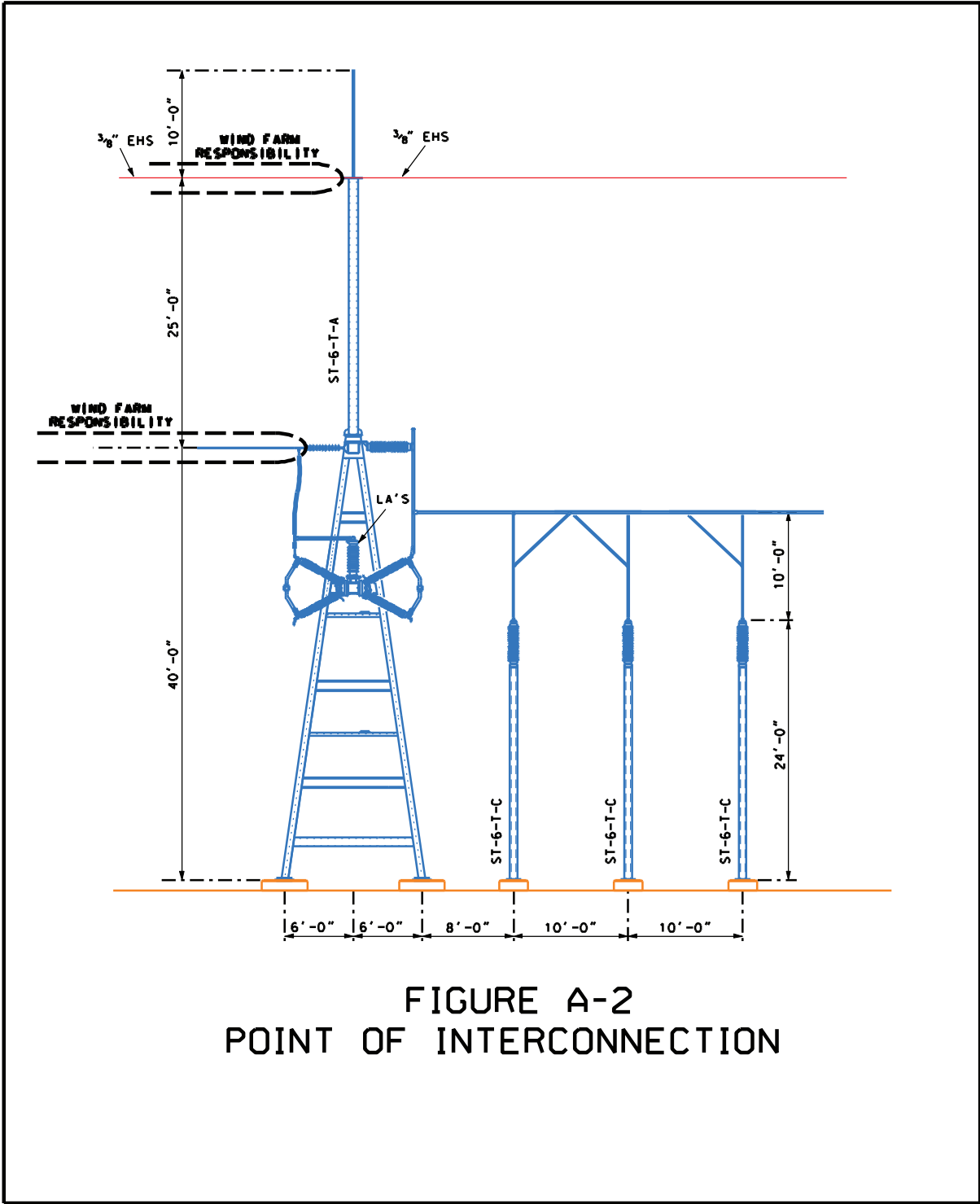

Figure A-1 Wind Farm Interconnection



**FIGURE A-2
POINT OF INTERCONNECTION**

Figure A-2 Point of Interconnection and Change of Ownership

**Appendix B
To Agreement**

Milestones – Amended August 2008

Action	Responsible Party	Completion Date
Complete Facilities Study	Transmission Provider	02/19/2004 - Completed
Suspension Notice	Interconnection Customer	02/11/2005
Unsuspending Notice	Interconnection Customer	02/08/2008
Provide authorization to proceed with design of Transmission Owner Interconnection Facilities to be constructed by Transmission Owner per Article 5.5.2	Interconnection Customer	01/09/2009
Provide payment of \$100,000 for engineering design of Transmission Owner Interconnection Facilities	Interconnection Customer	01/09/2009
Provide payment for the procurement of Transmission Owner Interconnection Facilities in the amount of \$150,000	Interconnection Customer	06/15/2009
Obtain Governmental Authorization (as necessary)	Interconnection Customer	
Provide authorization to proceed with construction of Transmission Owner Interconnection Facilities to be constructed by Transmission Owner per Article 5.6.3	Interconnection Customer	01/08/2010
Provide payment of \$248,580 for construction of Transmission Owner Interconnection Facilities to be constructed by Transmission Owner.	Interconnection Customer	01/08/2010
In-Service Date for Transmission Owner Interconnection Facilities	Transmission Owner	06/30/2010
In-Service Date & energization of Interconnection Customer's Interconnection Facilities	Interconnection Customer	08/01/2010
Initial Synchronization Date	Interconnection Customer	09/01/2010
Begin trial operation & testing per Article 6.1	Interconnection Customer & Transmission Owner	09/01/2010
Commercial operation date	Interconnection Customer	12/31/2010
Final accounting of costs incurred by Transmission Owner for construction of Transmission Owner Interconnection Facilities	Transmission Owner	To be submitted within six months of Completing Construction of the Transmission Owner Interconnection Facilities and Network Upgrades

Appendix C To Agreement

Interconnection Details

General: Transmission Provider, Transmission Owner, and Interconnection Customer agree that the Generating Facility cannot be, and is not equipped with Power System Stabilizers.

Transmission Provider, Transmission Owner, and Interconnection Customer agree that the operation of the Generating Facility with the proposed General Electric (GE) wind turbine generators with reactive power control capable of controlling the interconnection power factor shall satisfy the power factor requirements stated as follows. Over the full range of the wind farm's generating capacity, the power factor at the point of interconnection shall be within the range of 0.98 (generation absorbing VARS) to a 0.95 (generation supplying VARS) to the Transmission Owner's transmission system.

In order to accommodate possible minor changes in operating conditions, SPP, or the Transmission Operator may permit, at its sole discretion, adjustments to the specified limits.

Facility: The Interconnection Customer's Wind Energy Project is a new wind energy generation facility located approximately 3 miles east of Guymon, Oklahoma. The new wind energy generation facility will interconnect the 150 MW wind facility to the transmission on a new 115kV transmission line tied to Texas County Interchange. The new wind energy project's 115/34.5 kV interconnection substation will be located approximately 2 miles east of Guymon, Oklahoma. The 115/34.5 kV transformer will have a grounded wye connection on the 115 kV. This wind energy project will consist of 100 General Electric (GE) wind turbines with a nominal output of 1.5 MW each, for a nominal output of 150 MW.

Point of Interconnection: The Interconnection Customer's 115kV line will terminate at Transmission Owner's steel dead-end structure just inside the Texas County Interchange fence. Interconnection Customer will terminate the 115kV line with a single slack span of 795MCM ACSR conductor with 3/8" EHS static wire from the Interconnection Customer's dead-end structure to the Transmission Owner's Texas County Interchange steel dead-end structure. The line terminals will be designed to accommodate 2,000 pounds per phase conductor at maximum tension heavy-load and two shield wires designed to accommodate 2,000 pounds each at maximum tension heavy-load. The point of interconnection will be the connection between the Interconnection Customer's phase conductors terminated on their dead-end structure located just outside the Texas County Interchange fence, and the slack-span jumper. See Figure A-1, Wind Farm Interconnection and Figure A-2, Point of Interconnection in Appendix A.

Revenue Metering: At Texas County Interchange, Transmission Owner will install on the line to the Interconnection Customer's wind farm, billing meters with a 115 kV CTs for full 3 phase 4-wire metering. There will be two meters: one will be primary and the other will be back-up,

each will have full 4 quadrant metering. Metering pulses will be sent via SCADA to the Transmission Owner's Control Center in Amarillo, Texas.

Relay and Protection Scheme: On the 115kV line from Texas County Interchange to the Interconnection Customer's owned line, relaying will be step distance where a SEL 321-1 and SEL 311-C relays will be used. A SEL 279H-2 relay will be installed for line/bus conditions and sync check along with supervisory closing of the breaker. There will not be any automatic reclosing. A SEL 501-0 will be used for breaker failure.

Generator Under-frequency Response: SPP has a coordinated regional under-frequency load shedding and restoration plan. The requirements of that plan are detailed in SPP Criteria. The Interconnection Customer agrees that the under-frequency relay instantaneous trip setting shall be set not higher than the 58.5 Hz.

OPERATING GUIDELINES

SWITCHING AND TAGGING PROCEDURES

1. Definitions

- 1.1 CLEARANCE - The process of removing and holding a transmission line, section of bus or piece of equipment from service so that work may be safely performed.
- 1.2 CLEARANCE TAG - The formal registered tag in the Transmission Owner's Switching Procedures document. It is applied at the switches and disconnects through which electrical energy may be supplied to the section of line or equipment at which safety CLEARANCE is desired. It may be used with proper authority and registration at all voltage levels. A CLEARANCE TAG is NEVER used to hold circuits or equipment IN service.

2. Planned Clearance Request in the Facility Originated by Interconnection Customer

- 2.1 If the switching on the Facility requires switching of equipment owned by the Interconnection Customer and controlled by SPP or Transmission Owner, then the Interconnection Customer will send a Clearance Request to the Transmission Owner's or SPP's Transmission System operator to facilitate the switching.

3. Planned Clearance Request originated by Interconnection Customer

- 3.1 Any planned switching originated by the Interconnection Customer which requires switching of equipment controlled by SPP or Transmission Owner, will be coordinated with a Clearance Request through the Transmission Owner's transmission system operator with a minimum of 24 hours notice except in emergency situations (notices of between 24 hours and ten days may be required depending on the impact of the outage on the transmission grid). The Transmission Owner's transmission system operator will accommodate the request as soon as practicable. Personnel availability and system conditions may prevent a Clearance Request from being completed. The Interconnection Customer personnel will perform all switching and apply all CLEARANCE TAGS to equipment owned by the Interconnection Customer in the Interconnection Customer's substation. Transmission Owner personnel may observe the switching if desired.

4. Planned Clearance Request in the Interconnection Customer's Facilities originated by the Transmission Owner

- 4.1 All planned Clearance Requests on the Facility, which requires switching of equipment controlled by the Interconnection Customer and originated by SPP or Transmission Owner, will be coordinated with the Interconnection Customer's personnel by a Clearance Request submitted by Transmission Owner personnel

with a minimum of 48 hours notice except in emergency situations. The Interconnection Customer will accommodate the request as soon as practicable. All switching and application of CLEARANCE TAGS on equipment owned by Interconnection Customer, in the Interconnection Customer's Facilities, will be performed by the Interconnection Customer's personnel. Transmission Owner personnel will be allowed to observe all switching if desired. Once the Interconnection Customer's operator is assured that all devices are properly opened and tagged, the Interconnection Customer's personnel will provide CLEARANCE to the Transmission Owner's Transmission System Operator.

5. Planned Clearance Request originated by Transmission Owner

- 5.1 Interconnection Customer will be notified for informational purposes only of any planned Clearance Request on the Transmission System that do not require total isolation of the Interconnection Customer Facilities.
- 5.2 Any planned Clearance Requests that would result in the isolation of the Interconnection Customer Facilities from the Transmission System or in a reduction in interconnection capacity will be coordinated with the Interconnection Customer.

6. Unplanned Requests To Isolate Interconnection Customer Facilities By Remote Breaker Operations

- 6.1 Interconnection Customer may request the Transmission Owner's transmission system operator to isolate the Interconnection Customer Facilities from the Transmission Owner's system by remote opening breakers. The Transmission Owner's transmission system operator will accommodate the request as soon as practicable. System conditions may prevent such a request from being completed. Clearance will not be given and the Interconnection Customer's personnel must isolate the Interconnection Customer Facilities before starting work. If Clearance is required then request must be made under the procedures of Section 3.1 above.

7. Unplanned Outages

- 7.1 If an unplanned interruption occurs in either the Facility or the Transmission System, both the Transmission Owner's transmission system operator and the Interconnection Customer's personnel will provide the other with all pertinent information. This information will include, but may not be limited to:
 - 1. the devices involved,
 - 2. present status of devices in question,
 - 3. time stamps,
 - 4. cause of interruption (if available),
 - 5. relay targets (if available),
 - 6. any information helpful in determining cause and/or useful in the

restoration process

8. Re-energization

Procedures for Re-energizing Interconnection Customer's Facilities after Isolation from the Transmission Owner's System

8.1 Interconnection Customer's personnel must request the Transmission Owner's transmission system operator to re-energize the Interconnection Customer Facilities after they have become isolated.

9. Emergency Switching

Emergency Switching to Isolate the Interconnection Customer's Facilities from the Transmission Owner's System

9.1 During emergency situations, Transmission Owner's personnel may request Interconnection Customer's personnel to disconnect the generators at the Facility or Transmission Owner may disconnect generator remotely at the point of interconnect.

10 Communications Requirements

10.1 Interconnection Customer's operating personnel will notify the Transmission Owner's System Operator of the following:

- Prior to synchronization of when the Facility commences operation;
- Prior to the Facility ceasing operations;
- As soon as possible after an unplanned separation of all generators;
- For Clearance Requests for Interconnection Customer's equipment requiring switching on the Transmission Owner's system; and
- When abnormal system conditions are affecting the operation of the Interconnection Customer Facilities.

10.3 The Transmission Owner's System Operator will notify Interconnection Customer's operating personnel:

- When conditions may prevent generator synchronization;
- When conditions may require generator separation;
- On a requirement for generator separation;
- On the requirement for redispatch during a System Emergency; and
- For Clearance Request for Transmission Owner's operated equipment requiring switching on the Interconnection Customer's Interconnection Facilities.

10.4 Interconnection Customer's operating personnel will also be required to provide hourly meter readings (MWH and MVar) to the Transmission Owner's System Operator in the event of a telemetry failure from the Interconnection Facilities. This will occur at least once per day before 9:00 a.m. Central time.

10.5 It is also anticipated that the Transmission Owner's System Operator, SPP and Interconnection Customer's operating personnel will communicate, beyond the notices as listed above, as necessary and appropriate, in accordance with Good Utility Practice, to provide reliable and efficient operation of both the Transmission Owner's system and the Interconnection Customer's Facilities.

Appendix D To Agreement

Security Arrangements Details

Infrastructure security of Transmission System equipment and operations and control hardware and software is essential to ensure day-to-day Transmission System reliability and operational security. FERC will expect all Transmission Providers, market participants, and Interconnection Customers interconnected to the Transmission System to comply with the recommendations offered by the President's Critical Infrastructure Protection Board and, eventually, best practice recommendations from the electric reliability authority. All public utilities will be expected to meet basic standards for system infrastructure and operational security, including physical, operational, and cyber-security practices.

The Parties will cooperate reasonably to comply with the recommendations described in paragraph 1 and to implement the applicable standards. The following communications schematic diagram for the project including the Interconnection Customer, Transmission Provider (Southwest Power Pool, Inc.) and Transmission Owner (Southwestern Public Service) is provided to assist the Parties in meeting these standards.

Communications Schematic Diagram

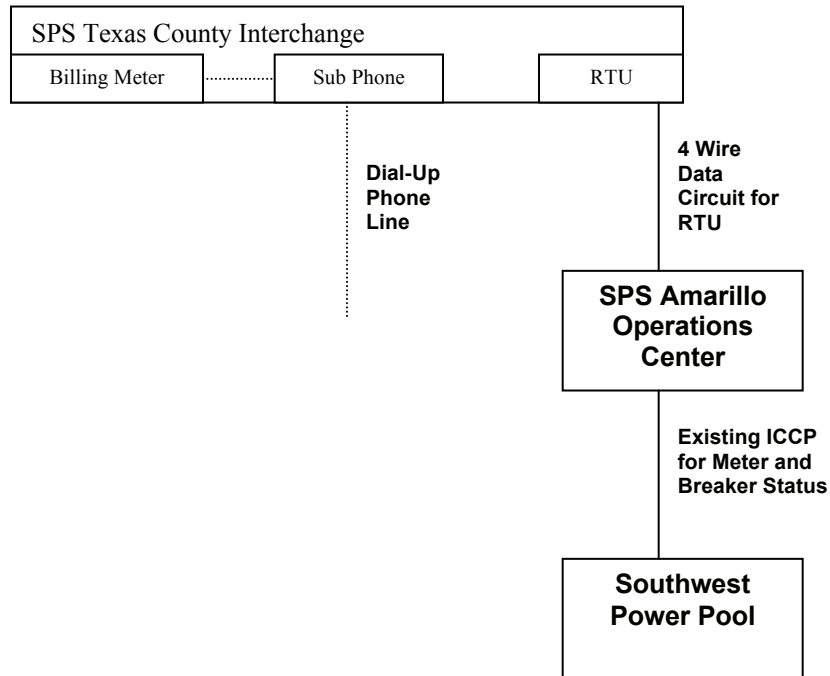

**Appendix E
To Agreement**

Commercial Operation Date

This Appendix E is a part of the Agreement between Transmission Provider, Transmission Owner and Interconnection Customer.

[Date]

Carl Monroe, Executive Vice President and Chief Operating Officer
Southwest Power Pool, Inc.
415 N. McKinley, Suite 140
Little Rock, AR 72205
Phone: 501-614-3200
Facsimile: 501-664-9553

Transmission Account Representative
Xcel Energy Services Inc.
6086 W. 48th St.
Amarillo, TX 79109

Re: East Guymon Wind Generating Facility

Dear _____:

On **[Date]** East Guymon Wind, LLC has completed Trial Operation of the Generating facility referenced in the Large Generation Interconnection Agreement signed on between East Guymon Wind, LLC, Southwestern Public Service Company, and Southwest Power Pool, Inc. This letter confirms that East Guymon Wind, LLC commenced Commercial Operation of the referenced Generating Facility, effective as of **[Date plus one day]**.

Thank you.

[Signature]

Project Manager
East Guymon Wind, LLC
c/o Edison Mission Energy
18101 Von Karman Ave., Suite 1700
Irvine, CA 92612

**Appendix F
To Agreement**

Addresses for Delivery of Notices and Billings

Notices:

Transmission Provider:

Carl Monroe, Executive Vice President and Chief Operating Officer
Southwest Power Pool, Inc.
415 N. McKinley, Suite 140
Little Rock, AR 72205-3020

Transmission Owner:

Transmission Account Representative
Xcel Energy Services Inc.
6086 W. 48th St.
Amarillo, TX 79109

Interconnection Customer:

East Guymon Project Manager
East Guymon Wind LLC
c/o Edison Mission Energy
18101 Von Karman Ave., Suite 1700
Irvine, CA 92612

Billings and Payments: [Specify addresses for construction invoices, O&M invoices and settlement of ancillary services]

Transmission Provider:

Tony Alexander, Supervisor of Tariff Accounting
Southwest Power Pool, Inc.
415 N. McKinley, Suite 140
Little Rock, AR 72205-3020

Transmission Owner:

Transmission Account Representative
Xcel Energy Services Inc.
6086 W. 48th St.
Amarillo, TX 79109

Interconnection Customer:

Project Manager
East Guymon Wind LLC
c/o Edison Mission Energy
18101 Von Karman Ave., Suite 1700
Irvine, CA 92612

Alternative Forms of Delivery of Notices (telephone, facsimile or email):

Transmission Provider:

Carl Monroe, Executive Vice President [and](#)
Chief Operating Officer
Southwest Power Pool, Inc.
[415 N. McKinley, Suite 140](#)
Little Rock, AR 72205
Phone: 501-614-3200
Facsimile: 501-664-9553

Transmission Owner:

Transmission Account Representative
Xcel Energy Services Inc.
6086 W. 48th St.
Amarillo, TX 79109
Phone: 806-640-6302
Facsimile: 806-457-6460

Interconnection Customer:

Project Manager

East Guymon Wind LLC
c/o Edison Mission Energy
18101 Von Karman Ave., Suite 1700
Irvine, CA 92612
Phone: 949-798-7407
Facsimile: 949-225-7228
ggriffin@edisonmission.com

Operational Communications:

Transmission Provider:

Lanny Nickell, Vice President, Operations
Southwest Power Pool, Inc.
415 N. McKinley, Suite 140
Little Rock, AR 72205
Phone: 501-614-3232
Facsimile: 501-664-9553

Transmission Owner:

SPS Transmission Operator
SPS Amarillo Operations Center
6086 W. 48th Street
Amarillo, TX 79109
Phone: 806-457-6343
Facsimile: 806-457-6349

Interconnection Customer:

Project Manager
East Guymon Wind LLC
c/o Edison Mission Energy
18101 Von Karman Ave., Suite 1700
Irvine, CA 92612
Phone: 949-798-7407
Facsimile: 949-225-7228
ggriffin@edisonmission.com

EXHIBIT III

August 14, 2008

East Guymon Project Manager
East Guymon Wind, LLC
c/o Edison Mission Energy
18101 Von Karman Ave., Suite 1700
Irvine, CA 92612

Attn: Mr. Bruce Kerr

Subject: Revised Appendices GEN-2002-006 Interconnection Agreement (East Guymon Wind, LLC)

Dear Mr. Kerr:

Attached please find the final and redlined version of the revised Appendices A-F and Appendix G to the GEN-2002-006 (East Guymon Wind, LLC) Interconnection Agreement dated November 29, 2004 (Service Agreement No. 1056).

Appendix A to the Agreement has been revised to update cost estimates that have changed during the period the LGIA was on suspension. Appendix B has been revised to update milestones for the Agreement that were out-of-date when the Agreement was placed into suspension. Appendix C has been revised to reflect specific changes in the project. Appendix D has been revised to reflect minor administrative edits. Appendices E and F have been revised to update contact information supplied by East Guymon Wind, LLC for the Agreement. Appendix G has no changes at this time but is included for completeness.

Please have the appropriate officer sign the signature page below and then forward the signature page to Southwestern Public Service Company (d/b/a Xcel Energy). After Southwestern Public Service Company has signed the execution page, the revised Appendices should be returned to SPP.

SPP is advising the Interconnection Customer that it will take six (6) months as a new market participant to prepare and equip itself to interact with the SPP EIS Market. The registration should be complete no later than forty-five (45) days prior to the energization of the interconnection.

If you have any questions you may contact John Mills at 501-614-3356.

Sincerely,

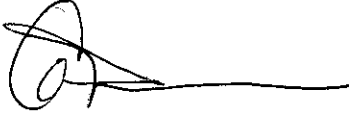

Carl Monroe, Executive Vice President and Chief Operating Officer
Southwest Power Pool, Inc.



IN WITNESS WHEREOF, the Parties have executed these revised Appendices A-F and Appendix G to the Interconnection Agreement.

**Southwestern Public Service Company
(d/b/a Xcel Energy)**

By:

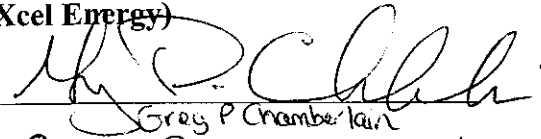

Greg P Chamberlain

Title:

Director, Portfolio Delivery & Integration

Date:

August 28, 2008

East Guymon Wind, LLC

By:

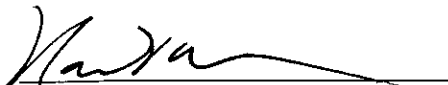

Randolph Mann

Title:

Vice President

Date:

August 21, 2008

Appendix A To Agreement

Interconnection Facilities, Network Upgrades and Distribution Upgrades

NOTE: The facilities described in this Appendix are based on the studies conducted in response to the Interconnection Request. In the event that other interconnection customers suspend, terminate or request unexecuted filing of their LGIAs, then additional studies may be required that could result in changes to the Interconnection Facilities and the Network Upgrades and in changes to Interconnection Customer's cost obligations for those facilities.

1. Interconnection Facilities:

(a) Interconnection Customer's Interconnection Facilities to be designed, procured, constructed and installed by Interconnection Customer at the Interconnection Customer's funding and sole expense. These facilities will be owned and controlled by Interconnection Customer:

The Interconnection Customer's new wind energy project's 115/34.5 kV interconnection substation will be located approximately 2 miles east of Guymon, Oklahoma. This wind energy project will consist of 100 General Electric (GE) wind turbines with a nominal output of 1.5 MW each, for a limited output of 150 MW.

The Interconnection Customer's Interconnection Facilities will be comprised of:

- five (5) or more 34.5 kV underground cable collection circuits;
- one (1) 34.5 kV to 115 kV transformation substation with associated 34.5 kV and 115 kV switchgear. The 34.5 kV to 115 kV transformer will have a grounded wye connection on the 115 kV side;
- one (1) new 115kV line that will tie the 115/34.5kV wind farm substation to the Point-of-Interconnection and Point-of-Change-of Ownership with the Transmission Owner's Texas County Interchange; and
- all necessary relay, protection, control and communication systems in the Interconnection Customers wind farm and interconnection substation required to protect Interconnection Customer's Generating Facilities and Interconnection Facilities and coordinate with Transmission Owner's relay, protection, control and communication systems.

(b) Transmission Owner's Interconnection Facilities to be designed, procured, constructed and installed by Transmission Owner at the Interconnection Customer's funding and sole expense. These facilities will be owned and controlled by the Transmission Owner:

- Modify the 115kV bus at Texas County. Interchange will be expanded to serve the Customer's new 115 kV line;
- 115kV transmission line termination from the Interconnection Customer's dead end structure at the Point of Interconnection into the Texas County Interchange;
- Additions to the control house to accommodate the required metering, protection and control devices, and terminal cabinets and misc. equipment;
- Revenue metering equipment to be installed on the transmission line to the wind farm; and
- Communications
-RTU communication will require 4-wire data circuit between Texas County Interchange and Xcel Energy's Amarillo Service Center

Total Cost \$ 498,580

2. Network Upgrades:

(a) Stand Alone Network Upgrades to be designed, procured, constructed and installed by Transmission Owner:

There are no Stand Alone Network Upgrades.

(b) Other Network Upgrades to be designed, procured, constructed and installed by Transmission Owner:

There are no other Network Upgrades.

(c) Joint Network Upgrades

There no Joint Network Upgrades.

(d) Previous Network Upgrades

There are no Previous Network Upgrades.

(e) The cost for the Transmission Owner's Interconnection Facilities to be constructed by Interconnection Customer is estimated at \$ 0.

(f) The total cost for the Transmission Owner's Interconnection Facilities to be constructed by the Transmission Owner at the Interconnection Customer's expense is estimated at \$498,580. The Interconnection Customer is responsible for the payment of the engineering, procurement and construction of the Transmission Owner's Interconnection Facilities estimated at \$498,580 pursuant to the schedule as indicated in Appendix B, Milestones.

All cost estimates were developed using a +/- 20 percent estimate according to the LGIP. All costs are estimated in 2008 dollars with no escalation applied for the purpose of this estimate. All estimates will be trued up for actual costs and expenses for purposes of final billing under Article 12.2.

(g) The portion of the Network Upgrades that is subject to the transmission service credits described in Section 11.4 of this Agreement is estimated at \$ 0.

3. Distribution Upgrades:

There are no Transmission Owner Distribution Upgrades

4. Interconnection Service: Interconnection Customer has selected the following:

 150 MW Energy Resource Interconnection Service
 MW Network Resource Interconnection Service within Transmission Owner's Control Area
 MW Network Resource Interconnection Service to outside Transmission Owner's Control Area

5. Construction Option Selected by Interconnection Customer:

Interconnection Customer has selected the Standard Option for construction of the Transmission Owner's Interconnection Facilities and the Network Upgrades.

6. Eligible Network Customers:

Not Used

7. Permits, Licenses and Authorizations:

The Interconnection Customer is responsible to secure all Permits, Licenses and Authorizations necessary for the construction and operation of its Generating Facilities and Interconnection Facilities.

WIND FARM INTERCONNECTION

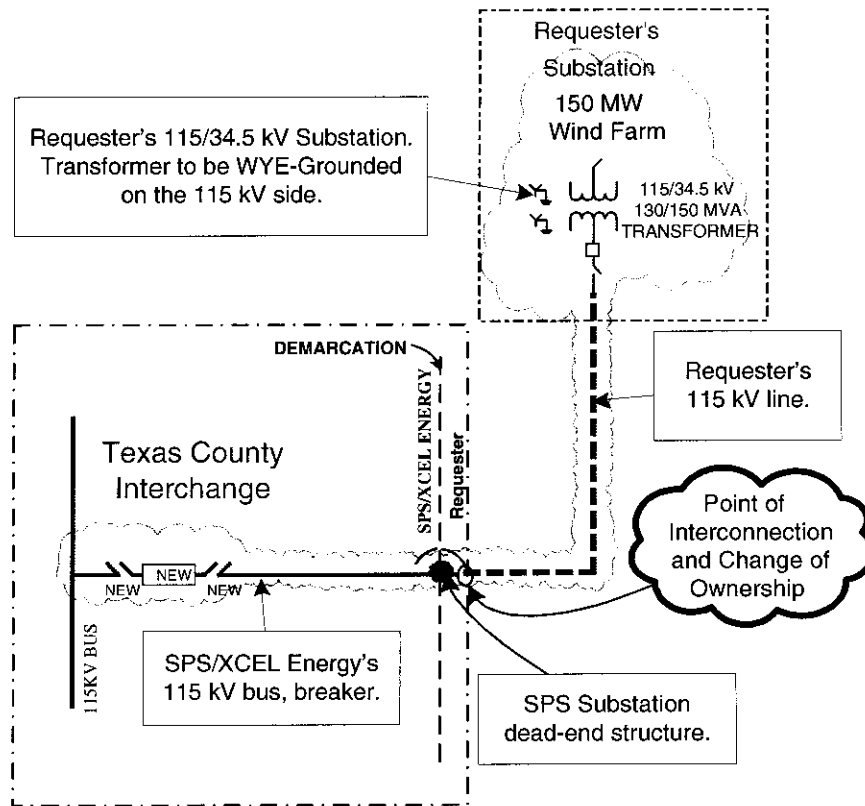
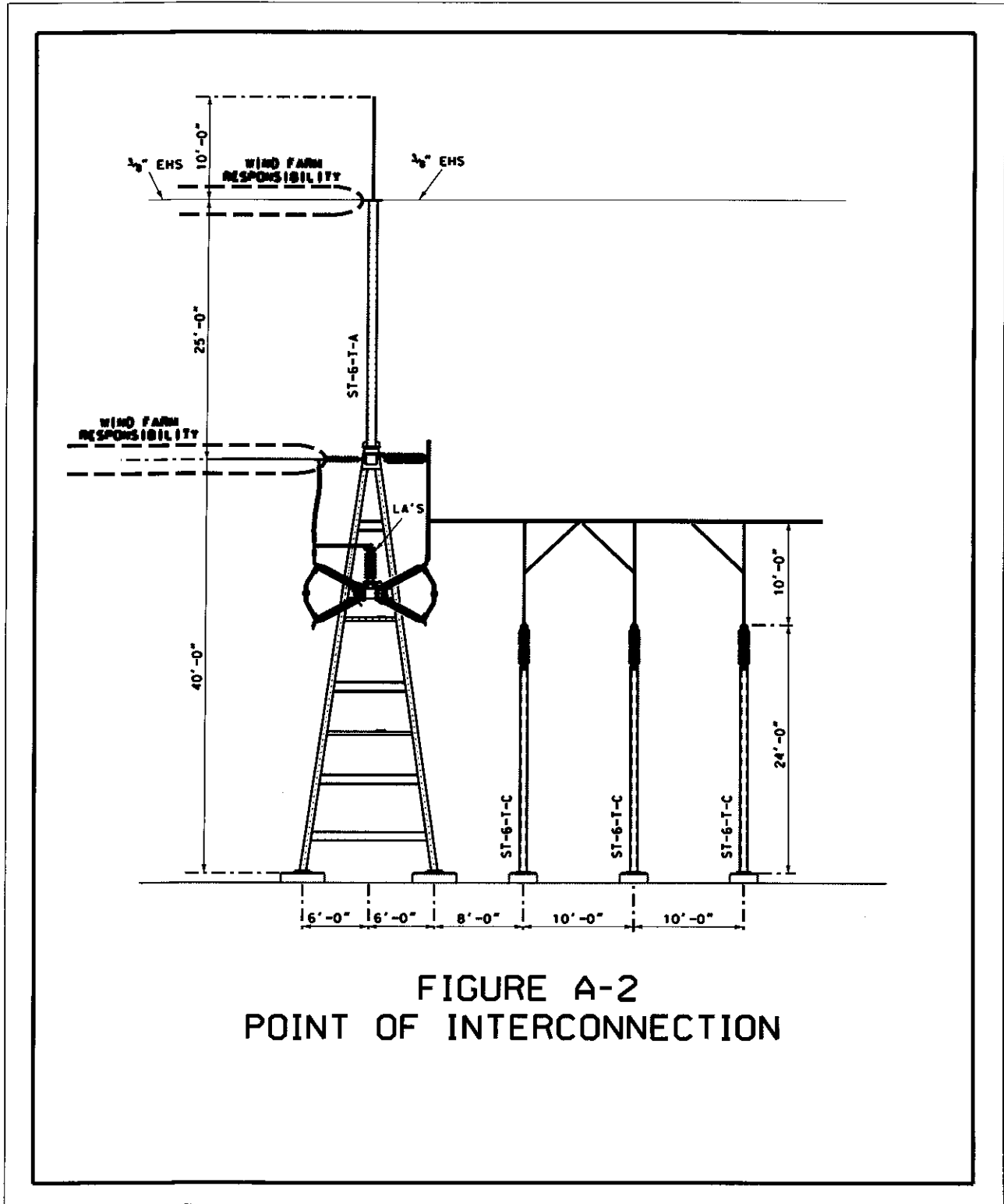

Figure A-1 Wind Farm Interconnection



**FIGURE A-2
POINT OF INTERCONNECTION**

Figure A-2 Point of Interconnection and Change of Ownership

**Appendix B
To Agreement**

Milestones – Amended August 2008

Action	Responsible Party	Completion Date
Complete Facilities Study	Transmission Provider	02/19/2004 - Completed
Suspension Notice	Interconnection Customer	02/11/2005
Unsuspenion Notice	Interconnection Customer	02/08/2008
Provide authorization to proceed with design of Transmission Owner Interconnection Facilities to be constructed by Transmission Owner per Article 5.5.2	Interconnection Customer	01/09/2009
Provide payment of \$100,000 for engineering design of Transmission Owner Interconnection Facilities	Interconnection Customer	01/09/2009
Provide payment for the procurement of Transmission Owner Interconnection Facilities in the amount of \$150,000	Interconnection Customer	06/15/2009
Obtain Governmental Authorization (as necessary)	Interconnection Customer	
Provide authorization to proceed with construction of Transmission Owner Interconnection Facilities to be constructed by Transmission Owner per Article 5.6.3	Interconnection Customer	01/08/2010
Provide payment of \$248,580 for construction of Transmission Owner Interconnection Facilities to be constructed by Transmission Owner.	Interconnection Customer	01/08/2010
In-Service Date for Transmission Owner Interconnection Facilities	Transmission Owner	06/30/2010
In-Service Date & energization of Interconnection Customer's Interconnection Facilities	Interconnection Customer	08/01/2010
Initial Synchronization Date	Interconnection Customer	09/01/2010
Begin trial operation & testing per Article 6.1	Interconnection Customer & Transmission Owner	09/01/2010
Commercial operation date	Interconnection Customer	12/31/2010
Final accounting of costs incurred by Transmission Owner for construction of Transmission Owner Interconnection Facilities	Transmission Owner	To be submitted within six months of Completing Construction of the Transmission Owner Interconnection Facilities and Network Upgrades

Appendix C To Agreement

Interconnection Details

General: Transmission Provider, Transmission Owner, and Interconnection Customer agree that the Generating Facility cannot be, and is not equipped with Power System Stabilizers.

Transmission Provider, Transmission Owner, and Interconnection Customer agree that the operation of the Generating Facility with the proposed General Electric (GE) wind turbine generators with reactive power control capable of controlling the interconnection power factor shall satisfy the power factor requirements stated as follows. Over the full range of the wind farm's generating capacity, the power factor at the point of interconnection shall be within the range of 0.98 (generation absorbing VARS) to a 0.95 (generation supplying VARS) to the Transmission Owner's transmission system.

In order to accommodate possible minor changes in operating conditions, SPP, or the Transmission Operator may permit, at its sole discretion, adjustments to the specified limits.

Facility: The Interconnection Customer's Wind Energy Project is a new wind energy generation facility located approximately 3 miles east of Guymon, Oklahoma. The new wind energy generation facility will interconnect the 150 MW wind facility to the transmission on a new 115kV transmission line tied to Texas County Interchange. The new wind energy project's 115/34.5 kV interconnection substation will be located approximately 2 miles east of Guymon, Oklahoma. The 115/34.5 kV transformer will have a grounded wye connection on the 115 kV. This wind energy project will consist of 100 General Electric (GE) wind turbines with a nominal output of 1.5 MW each, for a nominal output of 150 MW.

Point of Interconnection: The Interconnection Customer's 115kV line will terminate at Transmission Owner's steel dead-end structure just inside the Texas County Interchange fence. Interconnection Customer will terminate the 115kV line with a single slack span of 795MCM ACSR conductor with 3/8" EHS static wire from the Interconnection Customer's dead-end structure to the Transmission Owner's Texas County Interchange steel dead-end structure. The line terminals will be designed to accommodate 2,000 pounds per phase conductor at maximum tension heavy-load and two shield wires designed to accommodate 2,000 pounds each at maximum tension heavy-load. The point of interconnection will be the connection between the Interconnection Customer's phase conductors terminated on their dead-end structure located just outside the Texas County Interchange fence, and the slack-span jumper. See Figure A-1, Wind Farm Interconnection and Figure A-2, Point of Interconnection in Appendix A.

Revenue Metering: At Texas County Interchange, Transmission Owner will install on the line to the Interconnection Customer's wind farm, billing meters with a 115 kV CTs for full 3 phase 4-wire metering. There will be two meters: one will be primary and the other will be back-up,

each will have full 4 quadrant metering. Metering pulses will be sent via SCADA to the Transmission Owner's Control Center in Amarillo, Texas.

Relay and Protection Scheme: On the 115kV line from Texas County Interchange to the Interconnection Customer's owned line, relaying will be step distance where a SEL 321-1 and SEL 311-C relays will be used. A SEL 279H-2 relay will be installed for line/bus conditions and sync check along with supervisory closing of the breaker. There will not be any automatic reclosing. A SEL 501-0 will be used for breaker failure.

Generator Under-frequency Response: SPP has a coordinated regional under-frequency load shedding and restoration plan. The requirements of that plan are detailed in SPP Criteria. The Interconnection Customer agrees that the under-frequency relay instantaneous trip setting shall be set not higher than the 58.5 Hz.

OPERATING GUIDELINES

SWITCHING AND TAGGING PROCEDURES

1. **Definitions**

- 1.1 CLEARANCE - The process of removing and holding a transmission line, section of bus or piece of equipment from service so that work may be safely performed.
- 1.2 CLEARANCE TAG - The formal registered tag in the Transmission Owner's Switching Procedures document. It is applied at the switches and disconnects through which electrical energy may be supplied to the section of line or equipment at which safety CLEARANCE is desired. It may be used with proper authority and registration at all voltage levels. A CLEARANCE TAG is NEVER used to hold circuits or equipment IN service.

2. **Planned Clearance Request in the Facility Originated by Interconnection Customer**

- 2.1 If the switching on the Facility requires switching of equipment owned by the Interconnection Customer and controlled by SPP or Transmission Owner, then the Interconnection Customer will send a Clearance Request to the Transmission Owner's or SPP's Transmission System operator to facilitate the switching.

3. **Planned Clearance Request originated by Interconnection Customer**

- 3.1 Any planned switching originated by the Interconnection Customer which requires switching of equipment controlled by SPP or Transmission Owner, will be coordinated with a Clearance Request through the Transmission Owner's transmission system operator with a minimum of 24 hours notice except in emergency situations (notices of between 24 hours and ten days may be required depending on the impact of the outage on the transmission grid). The Transmission Owner's transmission system operator will accommodate the request as soon as practicable. Personnel availability and system conditions may prevent a Clearance Request from being completed. The Interconnection Customer personnel will perform all switching and apply all CLEARANCE TAGS to equipment owned by the Interconnection Customer in the Interconnection Customer's substation. Transmission Owner personnel may observe the switching if desired.

4. **Planned Clearance Request in the Interconnection Customer's Facilities originated by the Transmission Owner**

- 4.1 All planned Clearance Requests on the Facility, which requires switching of equipment controlled by the Interconnection Customer and originated by SPP or Transmission Owner, will be coordinated with the Interconnection Customer's personnel by a Clearance Request submitted by Transmission Owner personnel

with a minimum of 48 hours notice except in emergency situations. The Interconnection Customer will accommodate the request as soon as practicable. All switching and application of CLEARANCE TAGS on equipment owned by Interconnection Customer, in the Interconnection Customer's Facilities, will be performed by the Interconnection Customer's personnel. Transmission Owner personnel will be allowed to observe all switching if desired. Once the Interconnection Customer's operator is assured that all devices are properly opened and tagged, the Interconnection Customer's personnel will provide CLEARANCE to the Transmission Owner's Transmission System Operator.

5. Planned Clearance Request originated by Transmission Owner

- 5.1 Interconnection Customer will be notified for informational purposes only of any planned Clearance Request on the Transmission System that do not require total isolation of the Interconnection Customer Facilities.
- 5.2 Any planned Clearance Requests that would result in the isolation of the Interconnection Customer Facilities from the Transmission System or in a reduction in interconnection capacity will be coordinated with the Interconnection Customer.

6. Unplanned Requests To Isolate Interconnection Customer Facilities By Remote Breaker Operations

- 6.1 Interconnection Customer may request the Transmission Owner's transmission system operator to isolate the Interconnection Customer Facilities from the Transmission Owner's system by remote opening breakers. The Transmission Owner's transmission system operator will accommodate the request as soon as practicable. System conditions may prevent such a request from being completed. Clearance will not be given and the Interconnection Customer's personnel must isolate the Interconnection Customer Facilities before starting work. If Clearance is required then request must be made under the procedures of Section 3.1 above.

7. Unplanned Outages

- 7.1 If an unplanned interruption occurs in either the Facility or the Transmission System, both the Transmission Owner's transmission system operator and the Interconnection Customer's personnel will provide the other with all pertinent information. This information will include, but may not be limited to:
 - 1. the devices involved,
 - 2. present status of devices in question,
 - 3. time stamps,
 - 4. cause of interruption (if available),
 - 5. relay targets (if available),
 - 6. any information helpful in determining cause and/or useful in the

restoration process

8. **Re-energization**

Procedures for Re-energizing Interconnection Customer's Facilities after Isolation from the Transmission Owner's System

8.1 Interconnection Customer's personnel must request the Transmission Owner's transmission system operator to re-energize the Interconnection Customer Facilities after they have become isolated.

9. **Emergency Switching**

Emergency Switching to Isolate the Interconnection Customer's Facilities from the Transmission Owner's System

9.1 During emergency situations, Transmission Owner's personnel may request Interconnection Customer's personnel to disconnect the generators at the Facility or Transmission Owner may disconnect generator remotely at the point of interconnect.

10 **Communications Requirements**

10.1 Interconnection Customer's operating personnel will notify the Transmission Owner's System Operator of the following:

- Prior to synchronization of when the Facility commences operation;
- Prior to the Facility ceasing operations;
- As soon as possible after an unplanned separation of all generators;
- For Clearance Requests for Interconnection Customer's equipment requiring switching on the Transmission Owner's system; and
- When abnormal system conditions are affecting the operation of the Interconnection Customer Facilities.

10.3 The Transmission Owner's System Operator will notify Interconnection Customer's operating personnel:

- When conditions may prevent generator synchronization;
- When conditions may require generator separation;
- On a requirement for generator separation;
- On the requirement for redispatch during a System Emergency; and
- For Clearance Request for Transmission Owner's operated equipment requiring switching on the Interconnection Customer's Interconnection Facilities.

10.4 Interconnection Customer's operating personnel will also be required to provide hourly meter readings (MWH and MVar) to the Transmission Owner's System Operator in the event of a telemetry failure from the Interconnection Facilities. This will occur at least once per day before 9:00 a.m. Central time.

10.5 It is also anticipated that the Transmission Owner's System Operator, SPP and Interconnection Customer's operating personnel will communicate, beyond the notices as listed above, as necessary and appropriate, in accordance with Good Utility Practice, to provide reliable and efficient operation of both the Transmission Owner's system and the Interconnection Customer's Facilities.

Appendix D To Agreement

Security Arrangements Details

Infrastructure security of Transmission System equipment and operations and control hardware and software is essential to ensure day-to-day Transmission System reliability and operational security. FERC will expect all Transmission Providers, market participants, and Interconnection Customers interconnected to the Transmission System to comply with the recommendations offered by the President's Critical Infrastructure Protection Board and, eventually, best practice recommendations from the electric reliability authority. All public utilities will be expected to meet basic standards for system infrastructure and operational security, including physical, operational, and cyber-security practices.

The Parties will cooperate reasonably to comply with the recommendations described in paragraph 1 and to implement the applicable standards. The following communications schematic diagram for the project including the Interconnection Customer, Transmission Provider (Southwest Power Pool, Inc.) and Transmission Owner (Southwestern Public Service) is provided to assist the Parties in meeting these standards.

Communications Schematic Diagram

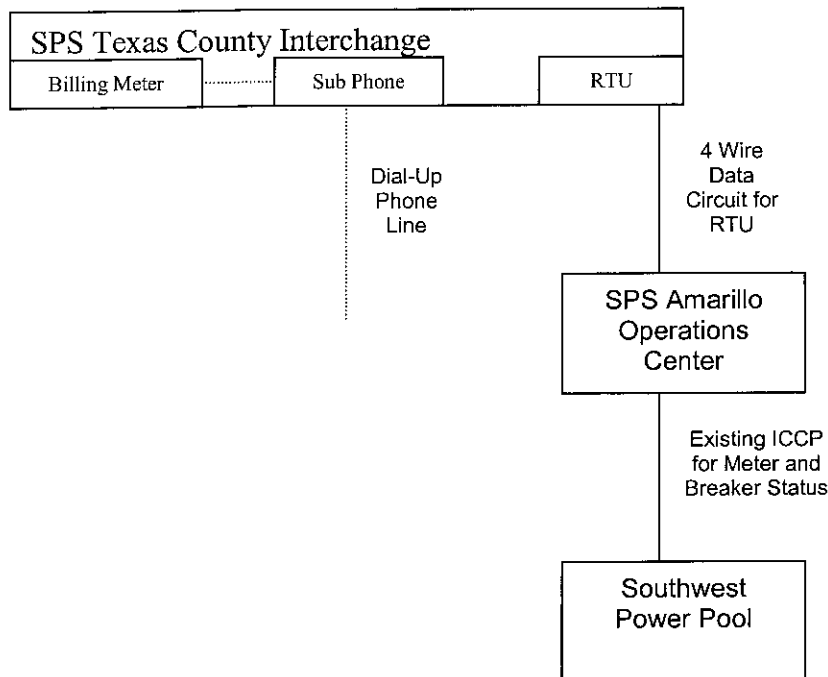

**Appendix E
To Agreement**

Commercial Operation Date

This Appendix E is a part of the Agreement between Transmission Provider, Transmission Owner and Interconnection Customer.

[Date]

Carl Monroe, Executive Vice President and Chief Operating Officer
Southwest Power Pool, Inc.
415 N. McKinley, Suite 140
Little Rock, AR 72205
Phone: 501-614-3200
Facsimile: 501-664-9553

Transmission Account Representative
Xcel Energy Services Inc.
6086 W. 48th St.
Amarillo, TX 79109

Re: East Guymon Wind Generating Facility

Dear _____:

On **[Date]** East Guymon Wind, LLC has completed Trial Operation of the Generating facility referenced in the Large Generation Interconnection Agreement signed on _____ between East Guymon Wind, LLC, Southwestern Public Service Company, and Southwest Power Pool, Inc. This letter confirms that East Guymon Wind, LLC commenced Commercial Operation of the referenced Generating Facility, effective as of **[Date plus one day]**.

Thank you.

[Signature]

Project Manager
East Guymon Wind, LLC
c/o Edison Mission Energy
18101 Von Karman Ave., Suite 1700
Irvine, CA 92612

**Appendix F
To Agreement**

Addresses for Delivery of Notices and Billings

Notices:

Transmission Provider:

Carl Monroe, Executive Vice President and Chief Operating Officer
Southwest Power Pool, Inc.
415 N. McKinley, Suite 140
Little Rock, AR 72205-3020

Transmission Owner:

Transmission Account Representative
Xcel Energy Services Inc.
6086 W. 48th St.
Amarillo, TX 79109

Interconnection Customer:

East Guymon Project Manager
East Guymon Wind LLC
c/o Edison Mission Energy
18101 Von Karman Ave., Suite 1700
Irvine, CA 92612

Billings and Payments: [Specify addresses for construction invoices, O&M invoices and settlement of ancillary services]

Transmission Provider:

Tony Alexander, Supervisor of Tariff Accounting
Southwest Power Pool, Inc.
415 N. McKinley, Suite 140
Little Rock, AR 72205-3020

Transmission Owner:

Transmission Account Representative
Xcel Energy Services Inc.
6086 W. 48th St.
Amarillo, TX 79109

Interconnection Customer:

Project Manager
East Guymon Wind LLC
c/o Edison Mission Energy
18101 Von Karman Ave., Suite 1700
Irvine, CA 92612

Alternative Forms of Delivery of Notices (telephone, facsimile or email):

Transmission Provider:

Carl Monroe, Executive Vice President and Chief Operating Officer
Southwest Power Pool, Inc.
415 N. McKinley, Suite 140
Little Rock, AR 72205
Phone: 501-614-3200
Facsimile: 501-664-9553

Transmission Owner:

Transmission Account Representative
Xcel Energy Services Inc.
6086 W. 48th St.
Amarillo, TX 79109
Phone: 806-640-6302
Facsimile: 806-457-6460

Interconnection Customer:

Project Manager
East Guymon Wind LLC

c/o Edison Mission Energy
18101 Von Karman Ave., Suite 1700
Irvine, CA 92612
Phone: 949-798-7407
Facsimile: 949-225-7228
ggriffin@edisonmission.com

Operational Communications:

Transmission Provider:

Lanny Nickell, Vice President, Operations
Southwest Power Pool, Inc.
415 N. McKinley, Suite 140
Little Rock, AR 72205
Phone: 501-614-3232
Facsimile: 501-664-9553

Transmission Owner:

SPS Transmission Operator
SPS Amarillo Operations Center
6086 W. 48th Street
Amarillo, TX 79109
Phone: 806-457-6343
Facsimile: 806-457-6349

Interconnection Customer:

Project Manager
East Guymon Wind LLC
c/o Edison Mission Energy
18101 Von Karman Ave., Suite 1700
Irvine, CA 92612
Phone: 949-798-7407
Facsimile: 949-225-7228
ggriffin@edisonmission.com

**Appendix G
To Agreement**

Requirements of Generators Relying on Newer Technologies

EXHIBIT IV

INTERCONNECTION AGREEMENT

entered into by the

Southwest Power Pool, Inc.,

Southwestern Public Service Company (d/b/a Xcel Energy),

And

East Guymon Wind L.L.C.

entered into on the 29th day of November, 2004

**Gen-2002-006
TABLE OF CONTENTS**

	Page
Recitals	1
Article 1. Definitions	2
Article 2. Effective Date, Term,, and Termination	11
2.1 Effective Date	12
2.2 Term of Agreement	12
2.3 Termination Procedures	12
2.3.1 Written Notice	12
2.3.2 Default	12
2.4 Termination Costs	12
2.5 Disconnection	13
2.6 Survival	13
Article 3. Regulatory Filings	14
3.1 Filing	14
Article 4. Scope of Service	14
4.1 Interconnection Product Options	14
4.1.1 Energy Resource Interconnection Service	14
4.1.1.1 The Product	14
4.1.1.2 Transmission Delivery Service Implications	14
4.1.2 Network Resource Interconnection Service	15
4.1.2.1 The Product	15
4.1.2.2 Transmission Delivery Service Implications	16
4.2 Provision of Service	18
4.3 Performance Standards	18
4.4 No Transmission Delivery Service	18
4.5 Interconnection Customer Provided Services	18
Article 5. Interconnection Facilities Engineering, Procurement, & Construction 18	
5.1 Options	18
5.1.1 Standard Option	18
5.1.2 Alternate Option	19
5.1.3 Option to Build	19
5.1.4 Negotiated Option	20

5.2	General Conditions Applicable to Option to Build	20
5.3	Liquidated Damages.....	22
5.4	Power System Stabilizers.....	23
5.5	Equipment Procurement.....	23
5.6	Construction Commencement.....	23
5.7	Work Progress	24
5.8	Information Exchange.....	24
5.9	Limited Operation	24
5.10	Interconnection Customer's Interconnection Facilities ('ICIF').....	24
	5.10.1 Interconnection Customer's Interconnection Facility Specifications.....	25
	5.10.2 Transmission Provider's Review	25
	5.10.3 ICIF Construction.....	25
5.11	Transmission Provider's Interconnection Facilities Construction ...	26
5.12	Access Rights.....	26
5.13	Lands of Other Property Owners	26
5.14	Permits.....	27
5.15	Early Construction of Base Case Facilities	27
5.16	Suspension	27
5.17	Taxes	28
	5.17.1 Interconnection Customer Payments Not Taxable.....	28
	5.17.2 Representations and Covenants	28
	5.17.3 Indemnification for the Cost Consequences of Current Tax Liability Imposed Upon the Transmission Provider.....	29
	5.17.4 Tax Gross-Up Amount	30
	5.17.5 Private Letter Ruling or Change or Clarification of Law ...	31
	5.17.6 Subsequent Taxable Events	31
	5.17.7 Contests.....	32
	5.17.8 Refund.....	33
	5.17.9 Taxes Other Than Income Taxes	34
	5.17.10 Transmission Owners Who Are Not Transmission Providers 34	
5.18	Tax Status.....	35
5.19	Modification	35
	5.19.1 General.....	35
	5.19.2 Standards.....	35
	5.19.3 Modification Costs	36
Article 6.	Testing and Inspection	36
6.1	Pre-Commercial Operation Date Testing and Modifications.....	36

6.2	Post-Commercial Operation Date Testing and Modifications	36
6.3	Right to Observe Testing	36
6.4	Right to Inspect.....	37
Article 7.	Metering.....	37
7.1	General	37
7.2	Check Meters	37
7.3	Standards.....	38
7.4	Testing of Metering Equipment	38
7.5	Metering Data	38
Article 8.	Communications	38
8.1	Interconnection Customer Obligations	38
8.2	Remote Terminal Unit.....	39
8.3	No Annexation	39
Article 9.	Operations	39
9.1	General	39
9.2	Control Area Notification	40
9.3	Transmission Provider Obligations	40
9.4	Interconnection Customer Obligations	40
9.5	Start-Up and Synchronization.....	40
9.6	Reactive Power.....	41
9.6.1	Power Factor Design Criteria	41
9.6.2	Voltage Schedules.....	41
9.6.2.1	Governors and Regulators.....	41
9.6.3	Payment for Reactive Power	42
9.7	Outages and Interruptions.....	42
9.7.1	Outages.....	42
9.7.1.1	Outage Authority and Coordination	42
9.7.1.2	Outage Schedules.....	42
9.7.1.3	Outage Restoration.....	43
9.7.2	Interruption of Service	43
9.7.3	Under-Frequency and Over Frequency Conditions	44
9.7.4	System Protection and Other Control Requirements.....	45
9.7.4.1	System Protection Facilities.....	45
9.7.5	Requirements for Protection	46
9.7.6	Power Quality	46
9.8	Switching and Tagging Rules	47
9.9	Use of Interconnection Facilities by Third Parties	47
9.9.1	Purpose of Interconnection Facilities	47

	9.9.2	Third Party Users.....	47
9.10		Disturbance Analysis Data Exchange.....	47
Article 10.		Maintenance.....	48
10.1		Transmission Provider Obligations	48
10.2		Interconnection Customer Obligations	48
10.3		Coordination	48
10.4		Secondary Systems	48
10.5		Operating and Maintenance Expenses	48
Article 11.		Performance Obligation	49
11.1		Interconnection Customer Interconnection Facilities.....	49
11.2		Transmission Provider's Interconnection Facilities.....	49
11.3		Network Upgrades and Distribution Upgrades	49
11.4		Transmission Credits	49
	11.4.1	Repayment of Amounts Advanced for Network Upgrades	49
11.5		Provision of Security	51
11.6		Interconnection Customer Compensation.....	51
	11.6.1	Interconnection Customer Compensation for Actions During Emergency Condition.....	52
Article 12.		Invoice.....	52
12.1		General	52
12.2		Final Invoice.....	52
12.3		Payment	52
12.4		Disputes	53
Article 13.		Emergencies	53
13.1		Definition	53
13.2		Obligations	53
13.3		Notice	53
13.4		Immediate Action	54
13.5		Transmission Provider Authority	54
	13.5.1	General.....	54
	13.5.2	Reduction and Disconnection	55
13.6		Interconnection Customer Authority	55
13.7		Limited Liability.....	56
Article 14.		Regulatory Requirements and Governing Law.....	56
14.1		Regulatory Requirements	56
14.2		Governing Law	56

Article 15.	Notices.....	56
15.1	General	56
15.2	Billings and Payments	57
15.3	Alternative Forms of Notice.....	57
15.4	Operations and Maintenance Notice	57
Article 16.	Force Majeure.....	57
Article 17.	Default	58
17.1	Default	58
17.1.1	General.....	58
17.1.2	Right to Terminate.....	58
Article 18.	Indemnity, Consequential Damages and Insurance.....	59
18.1	Indemnity	59
18.1.1	Indemnified Person.....	59
18.1.2	Indemnifying Party.....	59
18.1.3	Indemnity Procedures	59
18.2	Consequential Damages	60
18.3	Insurance	60
Article 19.	Assignment	63
Article 20.	Severability.....	63
Article 21.	Comparability	64
Article 22.	Confidentiality	64
22.1	Confidentiality	64
22.1.1	Term	64
22.1.2	Scope	64
22.1.3	Release of Confidential Information	65
22.1.4	Rights	65
22.1.5	No Warranties	65
22.1.6	Standard of Care.....	66
22.1.7	Order of Disclosure.....	66
22.1.8	Termination of Agreement.....	66
22.1.9	Remedies	66
22.1.10	Disclosure to FERC, its Staff, or a State.....	67
Article 23.	Environmental Releases	68

Article 24.	Information Requirements	68
24.1	Information Acquisition	68
24.2	Information Submission by Transmission Provider	69
24.3	Updated Information Submission by Interconnection Customer	69
24.4	Information Supplementation	69
Article 25.	Information Access and Audit Rights.....	70
25.1	Information Access	70
25.2	Reporting of Non-Force Majeure Events	70
25.3	Audit Rights	71
25.4	Audit Rights Periods	71
25.4.1	Audit Rights Period for Construction-Related Accounts and Records	71
25.4.2	Audit Rights Period for All Other Accounts and Records... ..	71
25.5	Audit Results	72
Article 26.	Subcontractors	72
26.1	General	72
26.2	Responsibility of Principal.....	72
26.3	No Limitation by Insurance.....	72
Article 27.	Disputes	72
27.1	Submission.....	72
27.2	External Arbitration Procedures	73
27.3	Arbitration Decisions	73
27.4	Costs.....	74
Article 28.	Representations, Warranties, and Covenants.....	74
28.1	General	74
28.1.1	Good Standing.....	74
28.1.2	Authority.....	74
28.1.3	No Conflict.....	74
28.1.4	Consent and Approval.....	75
Article 29.	Joint Operating Committee	75
Article 30.	Miscellaneous	76
30.1	Binding Effect	76
30.2	Conflicts.....	76
30.3	Rules of Interpretation.....	76
30.4	Entire Agreement	77
30.5	No Third Party Beneficiaries.....	77

30.6	Waiver	77
30.7	Headings	77
30.8	Multiple Counterparts	77
30.9	Amendment	77
30.10	Modification by the Parties.....	78
30.11	Reservation of Rights	78
30.12	No Partnership.....	78

Appendix A - Interconnection Facilities, Network Upgrades, and Distribution Upgrades

Appendix B – Milestones

Appendix C – Interconnection Details

Appendix D – Security Arrangements Details

Appendix E – Commercial Operation Date

Appendix F – Addresses for Delivery of Notices and Billings

Appendix G – Requirements of Generators Relying on Newer Technologies

STANDARD LARGE GENERATOR INTERCONNECTION AGREEMENT

THIS STANDARD LARGE GENERATOR INTERCONNECTION AGREEMENT ("Agreement") is made and entered into this ____ day of __ 2004, by and between East Guymon Wind LLC, a limited liability company organized and existing under the laws of the State of Delaware ("Interconnection Customer" with a Large Generating Facility), and Southwest Power Pool, Inc., a corporation organized and existing under the laws of the State of Arkansas ("Transmission Provider") and Southwestern Public Service Company (d/b/a Xcel Energy), a corporation organized and existing under the laws of the State of New Mexico ("Transmission Owner" or "Xcel Energy"). Interconnection Customer, Transmission Provider and Transmission Owner each may be referred to as a "Party" or collectively as the "Parties."

Recitals

WHEREAS, Transmission Provider operates the Transmission System; and

WHEREAS, Interconnection Customer intends to own, lease and/or control and operate the Generating Facility identified as a Large Generating Facility in Appendix C to this Agreement; and,

WHEREAS, Interconnection Customer and Transmission Provider have agreed to enter into this Agreement for the purpose of interconnecting the Large Generating Facility with the Transmission System;

NOW, THEREFORE, in consideration of and subject to the mutual covenants contained herein, it is agreed:

When used in this Standard Large Generator Interconnection Agreement, terms with initial capitalization that are not defined in Article 1 shall have the meanings specified in the Article in which they are used or the Open Access Transmission Tariff (OATT).

Article 1. Definitions

Adverse System Impact shall mean the negative effects due to technical or operational limits on conductors or equipment being exceeded that may compromise the safety and reliability of the electric system.

Affected System shall mean an electric system other than the Transmission Provider's Transmission System that may be affected by the proposed interconnection.

Affected System Operator shall mean the entity that operates an Affected System.

Affiliate shall mean, with respect to a corporation, partnership or other entity, each such other corporation, partnership or other entity that directly or indirectly, through one or more intermediaries, controls, is controlled by, or is under common control with, such corporation, partnership or other entity.

Ancillary Services shall mean those services that are necessary to support the transmission of capacity and energy from resources to loads while maintaining reliable operation of the Transmission Provider's Transmission System in accordance with Good Utility Practice.

Applicable Laws and Regulations shall mean all duly promulgated applicable federal, state and local laws, regulations, rules, ordinances, codes, decrees, judgments, directives, or judicial or administrative orders, permits and other duly authorized actions of any Governmental Authority.

Applicable Reliability Council shall mean the reliability council applicable to the Transmission System to which the Generating Facility is directly interconnected.

Applicable Reliability Standards shall mean the requirements and guidelines of NERC, the Applicable Reliability Council, and the Control Area of the Transmission System to which the Generating Facility is directly interconnected.

Base Case shall mean the base case power flow, short circuit, and stability data bases used for the Interconnection Studies by the Transmission Provider or Interconnection Customer.

Breach shall mean the failure of a Party to perform or observe any material term or condition of the Standard Large Generator Interconnection Agreement.

Breaching Party shall mean a Party that is in Breach of the Standard Large Generator Interconnection Agreement.

Business Day shall mean Monday through Friday, excluding Federal Holidays.

Calendar Day shall mean any day including Saturday, Sunday or a Federal Holiday.

Clustering shall mean the process whereby a group of Interconnection Requests is studied together, instead of serially, for the purpose of conducting the Interconnection System Impact Study.

Commercial Operation shall mean the status of a Generating Facility that has commenced generating electricity for sale, excluding electricity generated during Trial Operation.

Commercial Operation Date of a unit shall mean the date on which the Generating Facility commences Commercial Operation as agreed to by the Parties pursuant to Appendix E to the Standard Large Generator Interconnection Agreement.

Confidential Information shall mean any confidential, proprietary or trade secret information of a plan, specification, pattern, procedure, design, device, list, concept, policy or compilation relating to the present or planned business of a Party, which is designated as confidential by the Party supplying the information, whether conveyed orally, electronically, in writing, through inspection, or otherwise.

Control Area shall mean an electrical system or systems bounded by interconnection metering and telemetry, capable of controlling generation to maintain its interchange schedule with other Control Areas and contributing to frequency regulation of the interconnection. A Control Area must be certified by the Applicable Reliability Council.

Default shall mean the failure of a Breaching Party to cure its Breach in accordance with Article 17 of the Standard Large Generator Interconnection Agreement.

Dispute Resolution shall mean the procedure for resolution of a dispute between the Parties in which they will first attempt to resolve the dispute on an informal basis.

Distribution System shall mean the Transmission Provider's facilities and equipment used to transmit electricity to ultimate usage points such as homes and industries directly from nearby generators or from interchanges with higher voltage

transmission networks which transport bulk power over longer distances. The voltage levels at which distribution systems operate differ among areas.

Distribution Upgrades shall mean the additions, modifications, and upgrades to the Transmission Provider's Distribution System at or beyond the Point of Interconnection to facilitate interconnection of the Generating Facility and render the transmission service necessary to effect Interconnection Customer's wholesale sale of electricity in interstate commerce. Distribution Upgrades do not include Interconnection Facilities.

Effective Date shall mean the date on which the Standard Large Generator Interconnection Agreement becomes effective upon execution by the Parties subject to acceptance by FERC, or if filed unexecuted, upon the date specified by FERC.

Emergency Condition shall mean a condition or situation: (1) that in the judgment of the Party making the claim is imminently likely to endanger life or property; or (2) that, in the case of a Transmission Provider, is imminently likely (as determined in a non-discriminatory manner) to cause a material adverse effect on the security of, or damage to Transmission Provider's Transmission System, Transmission Provider's Interconnection Facilities or the electric systems of others to which the Transmission Provider's Transmission System is directly connected; or (3) that, in the case of Interconnection Customer, is imminently likely (as determined in a non-discriminatory manner) to cause a material adverse effect on the security of, or damage to, the Generating Facility or Interconnection Customer's Interconnection Facilities. System restoration and black start shall be considered Emergency Conditions; provided, that Interconnection Customer is not obligated by the Standard Large Generator Interconnection Agreement to possess black start capability.

Energy Resource Interconnection Service shall mean an Interconnection Service that allows the Interconnection Customer to connect its Generating Facility to the Transmission Provider's Transmission System to be eligible to deliver the Generating Facility's electric output using the existing firm or nonfirm capacity of the Transmission Provider's Transmission System on an as available basis. Energy Resource Interconnection Service in and of itself does not convey transmission service.

Engineering & Procurement (E&P) Agreement shall mean an agreement that authorizes the Transmission Provider to begin engineering and procurement of long lead-time items necessary for the establishment of the interconnection in order to advance the implementation of the Interconnection Request.

Environmental Law shall mean Applicable Laws or Regulations relating to pollution or protection of the environment or natural resources.

Federal Power Act shall mean the Federal Power Act, as amended, 16 U.S.C. §§ 791a et seq.

FERC shall mean the Federal Energy Regulatory Commission (Commission) or its successor.

Force Majeure shall mean any act of God, labor disturbance, act of the public enemy, war, insurrection, riot, fire, storm or flood, explosion, breakage or accident to machinery or equipment, any order, regulation or restriction imposed by governmental, military or lawfully established civilian authorities, or any other caused beyond a Party's control. A Force Majeure event does not include acts of negligence or intentional wrongdoing by the Party claiming Force Majeure.

Generating Facility shall mean Interconnection Customer's device for the production of electricity identified in the Interconnection Request, but shall not include the Interconnection Customer's Interconnection Facilities.

Generating Facility Capacity shall mean the net capacity of the Generating Facility and the aggregate net capacity of the Generating Facility where it includes multiple energy production devices.

Good Utility Practice shall mean any of the practices, methods and acts engaged in or approved by a significant portion of the electric industry during the relevant time period, or any of the practices, methods and acts which, in the exercise of reasonable judgment in light of the facts known at the time the decision was made, could have been expected to accomplish the desired result at a reasonable cost consistent with good business practices, reliability, safety and expedition. Good Utility Practice is not intended to be limited to the optimum practice, method, or act to the exclusion of all others, but rather to be acceptable practices, methods, or acts generally accepted in the region.

Governmental Authority shall mean any federal, state, local or other governmental regulatory or administrative agency, court, commission, department, board, or other governmental subdivision, legislature, rulemaking board, tribunal, or other governmental authority having jurisdiction over the Parties, their respective facilities, or the respective services they provide, and exercising or entitled to exercise any administrative, executive, police, or taxing authority or power; provided, however, that such term does not include Interconnection Customer, Transmission Provider, or any Affiliate thereof.

Hazardous Substances shall mean any chemicals, materials or substances defined

as or included in the definition of "hazardous substances," "hazardous wastes," "hazardous materials," "hazardous constituents," "restricted hazardous materials," "extremely hazardous substances," "toxic substances," "radioactive substances," "contaminants," "pollutants," "toxic pollutants" or words of similar meaning and regulatory effect under any applicable Environmental Law, or any other chemical, material or substance, exposure to which is prohibited, limited or regulated by any applicable Environmental Law.

Initial Synchronization Date shall mean the date upon which the Generating Facility is initially synchronized and upon which Trial Operation begins.

In-Service Date shall mean the date upon which the Interconnection Customer reasonably expects it will be ready to begin use of the Transmission Provider's Interconnection Facilities to obtain back feed power.

Interconnection Customer shall mean any entity, including the Transmission Provider, Transmission Owner or any of the Affiliates or subsidiaries of either, that proposes to interconnect its Generating Facility with the Transmission Provider's Transmission System.

Interconnection Customer's Interconnection Facilities shall mean all facilities and equipment, as identified in Appendix A of the Standard Large Generator Interconnection Agreement, that are located between the Generating Facility and the Point of Change of Ownership, including any modification, addition, or upgrades to such facilities and equipment necessary to physically and electrically interconnect the Generating Facility to the Transmission Provider's Transmission System. Interconnection Customer's Interconnection Facilities are sole use facilities.

Interconnection Facilities shall mean the Transmission Provider's Interconnection Facilities and the Interconnection Customer's Interconnection Facilities. Collectively, Interconnection Facilities include all facilities and equipment between the Generating Facility and the Point of Interconnection, including any modification, additions or upgrades that are necessary to physically and electrically interconnect the Generating Facility to the Transmission Provider's Transmission System. Interconnection Facilities are sole use facilities and shall not include Distribution Upgrades, Stand Alone Network Upgrades or Network Upgrades.

Interconnection Facilities Study shall mean a study conducted by the Transmission Provider or a third party consultant for the Interconnection Customer to determine a list of facilities (including Transmission Provider's Interconnection Facilities and Network Upgrades as identified in the Interconnection System Impact Study), the

cost of those facilities, and the time required to interconnect the Generating Facility with the Transmission Provider's Transmission System. The scope of the study is defined in Section 8 of the Standard Large Generator Interconnection Procedures.

Interconnection Facilities Study Agreement shall mean the form of agreement contained in Appendix 4 of the Standard Large Generator Interconnection Procedures for conducting the Interconnection Facilities Study.

Interconnection Feasibility Study shall mean a preliminary evaluation of the system impact and cost of interconnecting the Generating Facility to the Transmission Provider's Transmission System, the scope of which is described in Section 6 of the Standard Large Generator Interconnection Procedures.

Interconnection Feasibility Study Agreement shall mean the form of agreement contained in Appendix 2 of the Standard Large Generator Interconnection Procedures for conducting the Interconnection Feasibility Study.

Interconnection Request shall mean an Interconnection Customer's request, in the form of Appendix 1 to the Standard Large Generator Interconnection Procedures, in accordance with the Tariff, to interconnect a new Generating Facility, or to increase the capacity of, or make a Material Modification to the operating characteristics of, an existing Generating Facility that is interconnected with the Transmission Provider's Transmission System.

Interconnection Service shall mean the service provided by the Transmission Provider associated with interconnecting the Interconnection Customer's Generating Facility to the Transmission Provider's Transmission System and enabling it to receive electric energy and capacity from the Generating Facility at the Point of Interconnection, pursuant to the terms of the Standard Large Generator Interconnection Agreement and, if applicable, the Transmission Provider's Tariff.

Interconnection Study shall mean any of the following studies: the Interconnection Feasibility Study, the Interconnection System Impact Study, and the Interconnection Facilities Study described in the Standard Large Generator Interconnection Procedures.

Interconnection System Impact Study shall mean an engineering study that evaluates the impact of the proposed interconnection on the safety and reliability of Transmission Provider's Transmission System and, if applicable, an Affected System. The study shall identify and detail the system impacts that would result if the Generating Facility were interconnected without project modifications or system modifications,

focusing on the Adverse System Impacts identified in the Interconnection Feasibility Study, or to study potential impacts, including but not limited to those identified in the Scoping Meeting as described in the Standard Large Generator Interconnection Procedures.

Interconnection System Impact Study Agreement shall mean the form of agreement contained in Appendix 3 of the Standard Large Generator Interconnection Procedures for conducting the Interconnection System Impact Study.

IRS shall mean the Internal Revenue Service.

Joint Operating Committee shall be a group made up of representatives from Interconnection Customers and the Transmission Provider to coordinate operating and technical considerations of Interconnection Service.

Large Generating Facility shall mean a Generating Facility having a Generating Facility Capacity of more than 20 MW.

Loss shall mean any and all losses relating to injury to or death of any person or damage to property, demand, suits, recoveries, costs and expenses, court costs, attorney fees, and all other obligations by or to third parties, arising out of or resulting from the other Party's performance, or non-performance of its obligations under the Standard Large Generator Interconnection Agreement on behalf of the indemnifying Party, except in cases of gross negligence or intentional wrongdoing by the indemnifying Party.

Material Modification shall mean those modifications that have a material impact on the cost or timing of any Interconnection Request with a later queue priority date.

Metering Equipment shall mean all metering equipment installed or to be installed at the Generating Facility pursuant to the Standard Large Generator Interconnection Agreement at the metering points, including but not limited to instrument transformers, MWh-meters, data acquisition equipment, transducers, remote terminal unit, communications equipment, phone lines, and fiber optics.

NERC shall mean the North American Electric Reliability Council or its successor organization.

Network Resource shall mean any designated generating resource owned, purchased, or leased by a Network Customer under the Network Integration Transmission Service Tariff. Network Resources do not include any resource, or any portion thereof, that is committed for sale to third parties or otherwise cannot be called upon to meet the

Network Customer's Network Load on a non-interruptible basis.

Network Resource Interconnection Service shall mean an Interconnection Service that allows the Interconnection Customer to integrate its Large Generating Facility with the Transmission Provider's Transmission System (1) in a manner comparable to that in which the Transmission Provider integrates its generating facilities to serve native load customers; or (2) in an RTO or ISO with market based congestion management, in the same manner as all other Network Resources. Network Resource Interconnection Service in and of itself does not convey transmission service.

Network Upgrades shall mean the additions, modifications, and upgrades to the Transmission Provider's Transmission System required at or beyond the point at which the Interconnection Facilities connect to the Transmission Provider's Transmission System to accommodate the interconnection of the Large Generating Facility to the Transmission Provider's Transmission System.

Notice of Dispute shall mean a written notice of a dispute or claim that arises out of or in connection with the Standard Large Generator Interconnection Agreement or its performance.

Optional Interconnection Study shall mean a sensitivity analysis based on assumptions specified by the Interconnection Customer in the Optional Interconnection Study Agreement.

Optional Interconnection Study Agreement shall mean the form of agreement contained in Appendix 5 of the Standard Large Generator Interconnection Procedures for conducting the Optional Interconnection Study.

Party or Parties shall mean Transmission Provider, Transmission Owner, Interconnection Customer or any combination of the above.

Point of Change of Ownership shall mean the point, as set forth in Appendix A to the Standard Large Generator Interconnection Agreement, where the Interconnection Customer's Interconnection Facilities connect to the Transmission Provider's Interconnection Facilities.

Point of Interconnection shall mean the point, as set forth in Appendix A to the Standard Large Generator Interconnection Agreement, where the Interconnection Facilities connect to the Transmission Provider's Transmission System.

Queue Position shall mean the order of a valid Interconnection Request, relative

to all other pending valid Interconnection Requests, that is established based upon the date and time of receipt of the valid Interconnection Request by the Transmission Provider.

Reasonable Efforts shall mean, with respect to an action required to be attempted or taken by a Party under the Standard Large Generator Interconnection Agreement, efforts that are timely and consistent with Good Utility Practice and are otherwise substantially equivalent to those a Party would use to protect its own interests.

Scoping Meeting shall mean the meeting between representatives of the Interconnection Customer and Transmission Provider conducted for the purpose of discussing alternative interconnection options, to exchange information including any transmission data and earlier study evaluations that would be reasonably expected to impact such interconnection options, to analyze such information, and to determine the potential feasible Points of Interconnection.

Site Control shall mean documentation reasonably demonstrating: (1) ownership of, a leasehold interest in, or a right to develop a site for the purpose of constructing the Generating Facility; (2) an option to purchase or acquire a leasehold site for such purpose; or (3) an exclusivity or other business relationship between Interconnection Customer and the entity having the right to sell, lease or grant Interconnection Customer the right to possess or occupy a site for such purpose.

Small Generating Facility shall mean a Generating Facility that has a Generating Facility Capacity of no more than 20 MW.

Stand Alone Network Upgrades shall mean Network Upgrades that an Interconnection Customer may construct without affecting day-to-day operations of the Transmission System during their construction. Both the Transmission Provider and the Interconnection Customer must agree as to what constitutes Stand Alone Network Upgrades and identify them in Appendix A to the Standard Large Generator Interconnection Agreement.

Standard Large Generator Interconnection Agreement (LGIA) shall mean the form of interconnection agreement applicable to an Interconnection Request pertaining to a Large Generating Facility that is included in the Transmission Provider's Tariff.

Standard Large Generator Interconnection Procedures (LGIP) shall mean the interconnection procedures applicable to an Interconnection Request pertaining to a Large Generating Facility that are included in the Transmission Provider's Tariff.

System Protection Facilities shall mean the equipment, including necessary protection signal communications equipment, required to protect (1) the Transmission Provider's Transmission System from faults or other electrical disturbances occurring at the Generating Facility and (2) the Generating Facility from faults or other electrical system disturbances occurring on the Transmission Provider's Transmission System or on other delivery systems or other generating systems to which the Transmission Provider's Transmission System is directly connected.

Tariff shall mean the Transmission Provider's Tariff through which open access transmission service and Interconnection Service are offered, as filed with FERC, and as amended or supplemented from time to time, or any successor tariff.

Transmission Owner shall mean an entity that owns, leases or otherwise possesses an interest in the portion of the Transmission System at the Point of Interconnection and may be a Party to the Standard Large Generator Interconnection Agreement to the extent necessary.

Transmission Provider shall mean the public utility (or its designated agent) that owns, controls, or operates transmission or distribution facilities used for the transmission of electricity in interstate commerce and provides transmission service under the Tariff. The term Transmission Provider should be read to include the Transmission Owner when the Transmission Owner is separate from the Transmission Provider.

Transmission Provider's Interconnection Facilities shall mean all facilities and equipment owned, controlled or operated by the Transmission Provider from the Point of Change of Ownership to the Point of Interconnection as identified in Appendix A to the Standard Large Generator Interconnection Agreement, including any modifications, additions or upgrades to such facilities and equipment. Transmission Provider's Interconnection Facilities are sole use facilities and shall not include Distribution Upgrades, Stand Alone Network Upgrades or Network Upgrades.

Transmission System shall mean the facilities owned, controlled or operated by the Transmission Provider or Transmission Owner that are used to provide transmission service under the Tariff.

Trial Operation shall mean the period during which Interconnection Customer is engaged in on-site test operations and commissioning of the Generating Facility prior to Commercial Operation.

Article 2. Effective Date, Term, and Termination

2.1 Effective Date. This LGIA shall become effective upon execution by the Parties subject to acceptance by FERC (if applicable), or if filed unexecuted, upon the date specified by FERC. Transmission Provider shall promptly file this LGIA with FERC upon execution in accordance with Article 3.1, if required.

2.2 Term of Agreement. Subject to the provisions of Article 2.3, this LGIA shall remain in effect for a period of Twenty (20) years from the Effective Date and shall be automatically renewed for each successive one-year period thereafter.

2.3 Termination Procedures.

2.3.1 Written Notice. This LGIA may be terminated by Interconnection Customer after giving Transmission Provider ninety (90) Calendar Days advance written notice, or by Transmission Provider notifying FERC after the Generating Facility permanently ceases Commercial Operation.

2.3.2 Default. Either Party may terminate this LGIA in accordance with Article 17.

2.3.3 Notwithstanding Articles 2.3.1 and 2.3.2, no termination shall become effective until the Parties have complied with all Applicable Laws and Regulations applicable to such termination, including the filing with FERC of a notice of termination of this LGIA, which notice has been accepted for filing by FERC.

2.4 Termination Costs. If a Party elects to terminate this Agreement pursuant to Article 2.3 above, each Party shall pay all costs incurred (including any cancellation costs relating to orders or contracts for Interconnection Facilities and equipment) or charges assessed by the other Party, as of the date of the other Party's receipt of such notice of termination, that are the responsibility of the Terminating Party under this LGIA. In the event of termination by a Party, the Parties shall use commercially Reasonable Efforts to mitigate the costs, damages and charges arising as a consequence of termination. Upon termination of this LGIA, unless otherwise ordered or approved by FERC:

2.4.1 With respect to any portion of Transmission Provider's Interconnection Facilities that have not yet been constructed or installed, Transmission Provider shall to the extent possible and with Interconnection Customer's authorization cancel any pending orders of, or return, any materials or equipment for, or contracts for construction of, such facilities; provided that

in the event Interconnection Customer elects not to authorize such cancellation, Interconnection Customer shall assume all payment obligations with respect to such materials, equipment, and contracts, and Transmission Provider shall deliver such material and equipment, and, if necessary, assign such contracts, to Interconnection Customer as soon as practicable, at Interconnection Customer's expense. To the extent that Interconnection Customer has already paid Transmission Provider for any or all such costs of materials or equipment not taken by Interconnection Customer, Transmission Provider shall promptly refund such amounts to Interconnection Customer, less any costs, including penalties incurred by Transmission Provider to cancel any pending orders of or return such materials, equipment, or contracts.

If an Interconnection Customer terminates this LGIA, it shall be responsible for all costs incurred in association with that Interconnection Customer's interconnection, including any cancellation costs relating to orders or contracts for Interconnection Facilities and equipment, and other expenses including any Network Upgrades for which Transmission Provider has incurred expenses and has not been reimbursed by Interconnection Customer.

2.4.2 Transmission Provider may, at its option, retain any portion of such materials, equipment, or facilities that Interconnection Customer chooses not to accept delivery of, in which case Transmission Provider shall be responsible for all costs associated with procuring such materials, equipment, or facilities.

2.4.3 With respect to any portion of the Interconnection Facilities, and any other facilities already installed or constructed pursuant to the terms of this LGIA, Interconnection Customer shall be responsible for all costs associated with the removal, relocation or other disposition or retirement of such materials, equipment, or facilities.

2.5 Disconnection. Upon termination of this LGIA, the Parties will take all appropriate steps to disconnect the Large Generating Facility from the Transmission System. All costs required to effectuate such disconnection shall be borne by the terminating Party, unless such termination resulted from the non-terminating Party's Default of this LGIA or such non-terminating Party otherwise is responsible for these costs under this LGIA.

2.6 Survival. This LGIA shall continue in effect after termination to the extent

necessary to provide for final billings and payments and for costs incurred hereunder, including billings and payments pursuant to this LGIA; to permit the determination and enforcement of liability and indemnification obligations arising from acts or events that occurred while this LGIA was in effect; and to permit each Party to have access to the lands of the other Party pursuant to this LGIA or other applicable agreements, to disconnect, remove or salvage its own facilities and equipment.

Article 3. Regulatory Filings

3.1 Filing. Transmission Provider shall file this LGIA (and any amendment hereto) with the appropriate Governmental Authority, if required. Interconnection Customer may request that any information so provided be subject to the confidentiality provisions of Article 22. If Interconnection Customer has executed this LGIA, or any amendment thereto, Interconnection Customer shall reasonably cooperate with Transmission Provider with respect to such filing and to provide any information reasonably requested by Transmission Provider needed to comply with applicable regulatory requirements.

Article 4. Scope of Service

4.1 Interconnection Product Options. Interconnection Customer has selected the following (checked) type of Interconnection Service:

4.1.1 Energy Resource Interconnection Service.

4.1.1.1 The Product. Energy Resource Interconnection Service allows Interconnection Customer to connect the Large Generating Facility to the Transmission System and be eligible to deliver the Large Generating Facility's output using the existing firm or non-firm capacity of the Transmission System on an "as available" basis. To the extent Interconnection Customer wants to receive Energy Resource Interconnection Service, Transmission Provider shall construct facilities identified in Attachment A.

4.1.1.2 Transmission Delivery Service Implications. Under Energy Resource Interconnection Service, Interconnection Customer will be eligible to inject power from the Large Generating

Facility into and deliver power across the interconnecting Transmission Provider's Transmission System on an "as available" basis up to the amount of MWs identified in the applicable stability and steady state studies to the extent the upgrades initially required to qualify for Energy Resource Interconnection Service have been constructed. Where eligible to do so (e.g., PJM, ISO-NE, NYISO), Interconnection Customer may place a bid to sell into the market up to the maximum identified Large Generating Facility output, subject to any conditions specified in the interconnection service approval, and the Large Generating Facility will be dispatched to the extent Interconnection Customer's bid clears. In all other instances, no transmission delivery service from the Large Generating Facility is assured, but Interconnection Customer may obtain Point-to-Point Transmission Service, Network Integration Transmission Service, or be used for secondary network transmission service, pursuant to Transmission Provider's Tariff, up to the maximum output identified in the stability and steady state studies. In those instances, in order for Interconnection Customer to obtain the right to deliver or inject energy beyond the Large Generating Facility Point of Interconnection or to improve its ability to do so, transmission delivery service must be obtained pursuant to the provisions of Transmission Provider's Tariff. The Interconnection Customer's ability to inject its Large Generating Facility output beyond the Point of Interconnection, therefore, will depend on the existing capacity of Transmission Provider's Transmission System at such time as a transmission service request is made that would accommodate such delivery. The provision of firm Point-to-Point Transmission Service or Network Integration Transmission Service may require the construction of additional Network Upgrades.

4.1.2 Network Resource Interconnection Service.

4.1.2.1 The Product. Transmission Provider must conduct the necessary studies and construct the Network Upgrades needed to integrate the Large Generating Facility (1) in a manner comparable to that in which Transmission Provider integrates its generating facilities to serve native load customers; or (2)

in an ISO or RTO with market based congestion management, in the same manner as all Network Resources. To the extent Interconnection Customer wants to receive Network Resource Interconnection Service, Transmission Provider shall construct the facilities identified in Attachment A to this LGIA.

4.1.2.2 Transmission Delivery Service Implications. Network Resource Interconnection Service allows Interconnection Customer's Large Generating Facility to be designated by any Network Customer under the Tariff on Transmission Provider's Transmission System as a Network Resource, up to the Large Generating Facility's full output, on the same basis as existing Network Resources interconnected to Transmission Provider's Transmission System, and to be studied as a Network Resource on the assumption that such a designation will occur. Although Network Resource Interconnection Service does not convey a reservation of transmission service, any Network Customer under the Tariff can utilize its network service under the Tariff to obtain delivery of energy from the interconnected Interconnection Customer's Large Generating Facility in the same manner as it accesses other Network Resources. A Large Generating Facility receiving Network Resource Interconnection Service may also be used to provide Ancillary Services after technical studies and/or periodic analyses are performed with respect to the Large Generating Facility's ability to provide any applicable Ancillary Services, provided that such studies and analyses have been or would be required in connection with the provision of such Ancillary Services by any existing Network Resource. However, if an Interconnection Customer's Large Generating Facility has not been designated as a Network Resource by any load, it cannot be required to provide Ancillary Services except to the extent such requirements extend to all generating facilities that are similarly situated. The provision of Network Integration Transmission Service or firm Point-to-Point Transmission Service may require additional studies and the construction of additional upgrades. Because such studies and upgrades would be associated with a request for delivery service under the Tariff, cost responsibility for the studies and upgrades

would be in accordance with FERC's policy for pricing transmission delivery services.

Network Resource Interconnection Service does not necessarily provide Interconnection Customer with the capability to physically deliver the output of its Large Generating Facility to any particular load on Transmission Provider's Transmission System without incurring congestion costs. In the event of transmission constraints on Transmission Provider's Transmission System, Interconnection Customer's Large Generating Facility shall be subject to the applicable congestion management procedures in Transmission Provider's Transmission System in the same manner as all other Network Resources.

There is no requirement either at the time of study or interconnection, or at any point in the future, that Interconnection Customer's Large Generating Facility be designated as a Network Resource by a Network Service Customer under the Tariff or that Interconnection Customer identify a specific buyer (or sink). To the extent a Network Customer does designate the Large Generating Facility as a Network Resource, it must do so pursuant to Transmission Provider's Tariff.

Once an Interconnection Customer satisfies the requirements for obtaining Network Resource Interconnection Service, any future transmission service request for delivery from the Large Generating Facility within Transmission Provider's Transmission System of any amount of capacity and/or energy, up to the amount initially studied, will not require that any additional studies be performed or that any further upgrades associated with such Large Generating Facility be undertaken, regardless of whether or not such Large Generating Facility is ever designated by a Network Customer as a Network Resource and regardless of changes in ownership of the Large Generating Facility. However, the reduction or elimination of congestion or redispatch costs may require additional studies and the construction of additional upgrades.

To the extent Interconnection Customer enters into an arrangement for long term transmission service for deliveries from the Large Generating Facility outside Transmission Provider's Transmission System, such request may require additional studies and upgrades in order for Transmission Provider to grant such request.

- 4.2 Provision of Service.** Transmission Provider shall provide Interconnection Service for the Large Generating Facility at the Point of Interconnection.
- 4.3 Performance Standards.** Each Party shall perform all of its obligations under this LGIA in accordance with Applicable Laws and Regulations, Applicable Reliability Standards, and Good Utility Practice, and to the extent a Party is required or prevented or limited in taking any action by such regulations and standards, such Party shall not be deemed to be in Breach of this LGIA for its compliance therewith. If such Party is a Transmission Provider or Transmission Owner, then that Party shall amend the LGIA and submit the amendment to FERC for approval.
- 4.4 No Transmission Delivery Service.** The execution of this LGIA does not constitute a request for, nor the provision of, any transmission delivery service under Transmission Provider's Tariff, and does not convey any right to deliver electricity to any specific customer or Point of Delivery.
- 4.5 Interconnection Customer Provided Services.** The services provided by Interconnection Customer under this LGIA are set forth in Article 9.6 and Article 13.5.1. Interconnection Customer shall be paid for such services in accordance with Article 11.6.

Article 5. Interconnection Facilities Engineering, Procurement, and Construction

5.1 Options. Unless otherwise mutually agreed to between the Parties, Interconnection Customer shall select the In-Service Date, Initial Synchronization Date, and Commercial Operation Date; and either Standard Option or Alternate Option set forth below for completion of Transmission Provider's Interconnection Facilities and Network Upgrades as set forth in Appendix A, Interconnection Facilities and Network Upgrades, and such dates and selected option shall be set forth in Appendix B, Milestones.

5.1.1 Standard Option. Transmission Provider shall design, procure, and construct Transmission Provider's Interconnection Facilities and Network

Upgrades, using Reasonable Efforts to complete Transmission Provider's Interconnection Facilities and Network Upgrades by the dates set forth in Appendix B, Milestones. Transmission Provider shall not be required to undertake any action which is inconsistent with its standard safety practices, its material and equipment specifications, its design criteria and construction procedures, its labor agreements, and Applicable Laws and Regulations. In the event Transmission Provider reasonably expects that it will not be able to complete Transmission Provider's Interconnection Facilities and Network Upgrades by the specified dates, Transmission Provider shall promptly provide written notice to Interconnection Customer and shall undertake Reasonable Efforts to meet the earliest dates thereafter.

- 5.1.2 Alternate Option.** If the dates designated by Interconnection Customer are acceptable to Transmission Provider, Transmission Provider shall so notify Interconnection Customer within thirty (30) Calendar Days, and shall assume responsibility for the design, procurement and construction of Transmission Provider's Interconnection Facilities by the designated dates.

If Transmission Provider subsequently fails to complete Transmission Provider's Interconnection Facilities by the In-Service Date, to the extent necessary to provide back feed power; or fails to complete Network Upgrades by the Initial Synchronization Date to the extent necessary to allow for Trial Operation at full power output, unless other arrangements are made by the Parties for such Trial Operation; or fails to complete the Network Upgrades by the Commercial Operation Date, as such dates are reflected in Appendix B, Milestones; Transmission Provider shall pay Interconnection Customer liquidated damages in accordance with Article 5.3, Liquidated Damages, provided, however, the dates designated by Interconnection Customer shall be extended day for day for each day that the applicable RTO or ISO refuses to grant clearances to install equipment.

- 5.1.3 Option to Build.** If the dates designated by Interconnection Customer are not acceptable to Transmission Provider, Transmission Provider shall so notify Interconnection Customer within thirty (30) Calendar Days, and unless the Parties agree otherwise, Interconnection Customer shall have the option to assume responsibility for the design, procurement and construction of Transmission Provider's Interconnection Facilities and Stand Alone Network Upgrades on the dates specified in Article 5.1.2. Transmission Provider and Interconnection Customer must agree as to what constitutes Stand Alone Network Upgrades and identify such Stand Alone Network Upgrades in Appendix A. Except for Stand Alone Network

Upgrades, Interconnection Customer shall have no right to construct Network Upgrades under this option.

5.1.4 Negotiated Option. If Interconnection Customer elects not to exercise its option under Article 5.1.3, Option to Build, Interconnection Customer shall so notify Transmission Provider within thirty (30) Calendar Days, and the Parties shall in good faith attempt to negotiate terms and conditions (including revision of the specified dates and liquidated damages, the provision of incentives or the procurement and construction of a portion of Transmission Provider's Interconnection Facilities and Stand Alone Network Upgrades by Interconnection Customer) pursuant to which Transmission Provider is responsible for the design, procurement and construction of Transmission Provider's Interconnection Facilities and Network Upgrades. If the Parties are unable to reach agreement on such terms and conditions, Transmission Provider shall assume responsibility for the design, procurement and construction of Transmission Provider's Interconnection Facilities and Network Upgrades pursuant to 5.1.1, Standard Option.

5.2 General Conditions Applicable to Option to Build. If Interconnection Customer assumes responsibility for the design, procurement and construction of Transmission Provider's Interconnection Facilities and Stand Alone Network Upgrades,

(1) Interconnection Customer shall engineer, procure equipment, and construct Transmission Provider's Interconnection Facilities and Stand Alone Network Upgrades (or portions thereof) using Good Utility Practice and using standards and specifications provided in advance by Transmission Provider;

(2) Interconnection Customer's engineering, procurement and construction of Transmission Provider's Interconnection Facilities and Stand Alone Network Upgrades shall comply with all requirements of law to which Transmission Provider would be subject in the engineering, procurement or construction of Transmission Provider's Interconnection Facilities and Stand Alone Network Upgrades;

(3) Transmission Provider shall review and approve the engineering design, equipment acceptance tests, and the construction of Transmission Provider's Interconnection Facilities and Stand Alone Network Upgrades;

(4) prior to commencement of construction, Interconnection Customer shall provide to Transmission Provider a schedule for construction of Transmission Provider's Interconnection Facilities and Stand Alone Network Upgrades, and shall promptly respond to requests for information from Transmission Provider;

(5) at any time during construction, Transmission Provider shall have the right to gain unrestricted access to Transmission Provider's Interconnection Facilities and Stand Alone Network Upgrades and to conduct inspections of the same;

(6) at any time during construction, should any phase of the engineering, equipment procurement, or construction of Transmission Provider's Interconnection Facilities and Stand Alone Network Upgrades not meet the standards and specifications provided by Transmission Provider, Interconnection Customer shall be obligated to remedy deficiencies in that portion of Transmission Provider's Interconnection Facilities and Stand Alone Network Upgrades;

(7) Interconnection Customer shall indemnify Transmission Provider for claims arising from Interconnection Customer's construction of Transmission Provider's Interconnection Facilities and Stand Alone Network Upgrades under the terms and procedures applicable to Article 18.1 Indemnity;

(8) Interconnection Customer shall transfer control of Transmission Provider's Interconnection Facilities and Stand Alone Network Upgrades to Transmission Provider;

(9) Unless Parties otherwise agree, Interconnection Customer shall transfer ownership of Transmission Provider's Interconnection Facilities and Stand-Alone Network Upgrades to Transmission Provider;

(10) Transmission Provider shall approve and accept for operation and maintenance Transmission Provider's Interconnection Facilities and Stand Alone Network Upgrades to the extent engineered, procured, and constructed in accordance with this Article 5.2; and

(11) Interconnection Customer shall deliver to Transmission Provider "as-built" drawings, information, and any other documents that are reasonably required by Transmission Provider to assure that the Interconnection

Facilities and Stand-Alone Network Upgrades are built to the standards and specifications required by Transmission Provider.

5.3 Liquidated Damages. The actual damages to Interconnection Customer, in the event Transmission Provider's Interconnection Facilities or Network Upgrades are not completed by the dates designated by Interconnection Customer and accepted by Transmission Provider pursuant to subparagraphs 5.1.2 or 5.1.4, above, may include Interconnection Customer's fixed operation and maintenance costs and lost opportunity costs. Such actual damages are uncertain and impossible to determine at this time. Because of such uncertainty, any liquidated damages paid by Transmission Provider to Interconnection Customer in the event that Transmission Provider does not complete any portion of Transmission Provider's Interconnection Facilities or Network Upgrades by the applicable dates, shall be an amount equal to ½ of 1 percent per day of the actual cost of Transmission Provider's Interconnection Facilities and Network Upgrades, in the aggregate, for which Transmission Provider has assumed responsibility to design, procure and construct.

However, in no event shall the total liquidated damages exceed 20 percent of the actual cost of Transmission Provider's Interconnection Facilities and Network Upgrades for which Transmission Provider has assumed responsibility to design, procure, and construct. The foregoing payments will be made by Transmission Provider to Interconnection Customer as just compensation for the damages caused to Interconnection Customer, which actual damages are uncertain and impossible to determine at this time, and as reasonable liquidated damages, but not as a penalty or a method to secure performance of this LGIA. Liquidated damages, when the Parties agree to them, are the exclusive remedy for the Transmission Provider's failure to meet its schedule.

No liquidated damages shall be paid to Interconnection Customer if: (1) Interconnection Customer is not ready to commence use of Transmission Provider's Interconnection Facilities or Network Upgrades to take the delivery of power for the Large Generating Facility's Trial Operation or to export power from the Large Generating Facility on the specified dates, unless Interconnection Customer would have been able to commence use of Transmission Provider's Interconnection Facilities or Network Upgrades to take the delivery of power for Large Generating Facility's Trial Operation or to export power from the Large Generating Facility, but for Transmission Provider's delay; (2) Transmission Provider's failure to meet the specified dates is the result of the action or inaction of Interconnection Customer or any other Interconnection Customer who has entered into an LGIA with Transmission Provider or any cause beyond Transmission Provider's reasonable control or reasonable ability to cure; (3) the

interconnection Customer has assumed responsibility for the design, procurement and construction of Transmission Provider's Interconnection Facilities and Stand Alone Network Upgrades; or (4) the Parties have otherwise agreed.

5.4 Power System Stabilizers. The Interconnection Customer shall procure, install, maintain and operate Power System Stabilizers in accordance with the guidelines and procedures established by the Applicable Reliability Council. Transmission Provider reserves the right to reasonably establish minimum acceptable settings for any installed Power System Stabilizers, subject to the design and operating limitations of the Large Generating Facility. If the Large Generating Facility's Power System Stabilizers are removed from service or not capable of automatic operation, Interconnection Customer shall immediately notify Transmission Provider's system operator, or its designated representative. The requirements of this paragraph shall not apply to wind generators.

5.5 Equipment Procurement. If responsibility for construction of Transmission Provider's Interconnection Facilities or Network Upgrades is to be borne by Transmission Provider, then Transmission Provider shall commence design of Transmission Provider's Interconnection Facilities or Network Upgrades and procure necessary equipment as soon as practicable after all of the following conditions are satisfied, unless the Parties otherwise agree in writing:

5.5.1 Transmission Provider has completed the Facilities Study pursuant to the Facilities Study Agreement;

5.5.2 Transmission Provider has received written authorization to proceed with design and procurement from Interconnection Customer by the date specified in Appendix B, Milestones; and

5.5.3 Interconnection Customer has provided security to Transmission Provider in accordance with Article 11.5 by the dates specified in Appendix B, Milestones.

5.6 Construction Commencement. Transmission Provider shall commence construction of Transmission Provider's Interconnection Facilities and Network Upgrades for which it is responsible as soon as practicable after the following additional conditions are satisfied:

5.6.1 Approval of the appropriate Governmental Authority has been obtained for any facilities requiring regulatory approval;

- 5.6.2** Necessary real property rights and rights-of-way have been obtained, to the extent required for the construction of a discrete aspect of Transmission Provider's Interconnection Facilities and Network Upgrades;
- 5.6.3** Transmission Provider has received written authorization to proceed with construction from Interconnection Customer by the date specified in Appendix B, Milestones; and
- 5.6.4** Interconnection Customer has provided security to Transmission Provider in accordance with Article 11.5 by the dates specified in Appendix B, Milestones.
- 5.7 Work Progress.** The Parties will keep each other advised periodically as to the progress of their respective design, procurement and construction efforts. Either Party may, at any time, request a progress report from the other Party. If, at any time, Interconnection Customer determines that the completion of Transmission Provider's Interconnection Facilities will not be required until after the specified In-Service Date, Interconnection Customer will provide written notice to Transmission Provider of such later date upon which the completion of Transmission Provider's Interconnection Facilities will be required.
- 5.8 Information Exchange.** As soon as reasonably practicable after the Effective Date, the Parties shall exchange information regarding the design and compatibility of the Parties' Interconnection Facilities and compatibility of the Interconnection Facilities with Transmission Provider's Transmission System, and shall work diligently and in good faith to make any necessary design changes.
- 5.9 Limited Operation.** If any of Transmission Provider's Interconnection Facilities or Network Upgrades are not reasonably expected to be completed prior to the Commercial Operation Date of the Large Generating Facility, Transmission Provider shall, upon the request and at the expense of Interconnection Customer, perform operating studies on a timely basis to determine the extent to which the Large Generating Facility and Interconnection Customer's Interconnection Facilities may operate prior to the completion of Transmission Provider's Interconnection Facilities or Network Upgrades consistent with Applicable Laws and Regulations, Applicable Reliability Standards, Good Utility Practice, and this LGIA. Transmission Provider shall permit Interconnection Customer to operate the Large Generating Facility and Interconnection Customer's Interconnection Facilities in accordance with the results of such studies.
- 5.10 Interconnection Customer's Interconnection Facilities ('ICIF').**

Interconnection Customer shall, at its expense, design, procure, construct, own and install the ICIF, as set forth in Appendix A, Interconnection Facilities, Network Upgrades and Distribution Upgrades.

5.10.1 Interconnection Customer's Interconnection Facility

Specifications. Interconnection Customer shall submit initial specifications for the ICIF, including System Protection Facilities, to Transmission Provider at least one hundred eighty (180) Calendar Days prior to the Initial Synchronization Date; and final specifications for review and comment at least ninety (90) Calendar Days prior to the Initial Synchronization Date. Transmission Provider shall review such specifications to ensure that the ICIF are compatible with the technical specifications, operational control, and safety requirements of Transmission Provider and comment on such specifications within thirty (30) Calendar Days of Interconnection Customer's submission. All specifications provided hereunder shall be deemed confidential.

5.10.2 Transmission Provider's Review. Transmission Provider's review of Interconnection Customer's final specifications shall not be construed as confirming, endorsing, or providing a warranty as to the design, fitness, safety, durability or reliability of the Large Generating Facility, or the ICIF. Interconnection Customer shall make such changes to the ICIF as may reasonably be required by Transmission Provider, in accordance with Good Utility Practice, to ensure that the ICIF are compatible with the technical specifications, operational control, and safety requirements of Transmission Provider.

5.10.3 ICIF Construction. The ICIF shall be designed and constructed in accordance with Good Utility Practice. Within one hundred twenty (120) Calendar Days after the Commercial Operation Date, unless the Parties agree on another mutually acceptable deadline, Interconnection Customer shall deliver to Transmission Provider "as-built" drawings, information and documents for the ICIF, such as: a one-line diagram, a site plan showing the Large Generating Facility and the ICIF, plan and elevation drawings showing the layout of the ICIF, a relay functional diagram, relaying AC and DC schematic wiring diagrams and relay settings for all facilities associated with Interconnection Customer's step-up transformers, the facilities connecting the Large Generating Facility to the step-up transformers

and the ICIF, and the impedances (determined by factory tests) for the associated step-up transformers and the Large Generating Facility. The Interconnection Customer shall provide Transmission Provider specifications for the excitation system, automatic voltage regulator, Large Generating Facility control and protection settings, transformer tap settings, and communications, if applicable.

5.11 Transmission Provider's Interconnection Facilities Construction.

Transmission Provider's Interconnection Facilities shall be designed and constructed in accordance with Good Utility Practice. Upon request, within one hundred twenty (120) Calendar Days after the Commercial Operation Date, unless the Parties agree on another mutually acceptable deadline, Transmission Provider shall deliver to Interconnection Customer the following "as-built" drawings, information and documents for Transmission Provider's Interconnection Facilities [include appropriate drawings and relay diagrams].

Transmission Provider will obtain control of Transmission Provider's Interconnection Facilities and Stand Alone Network Upgrades upon completion of such facilities.

5.12 Access Rights. Upon reasonable notice and supervision by a Party, and subject to any required or necessary regulatory approvals, a Party ("Granting Party") shall furnish at no cost to the other Party ("Access Party") any rights of use, licenses, rights of way and easements with respect to lands owned or controlled by the Granting Party, its agents (if allowed under the applicable agency agreement), or any Affiliate, that are necessary to enable the Access Party to obtain ingress and egress to construct, operate, maintain, repair, test (or witness testing), inspect, replace or remove facilities and equipment to: (i) interconnect the Large Generating Facility with the Transmission System; (ii) operate and maintain the Large Generating Facility, the Interconnection Facilities and the Transmission System; and (iii) disconnect or remove the Access Party's facilities and equipment upon termination of this LGIA. In exercising such licenses, rights of way and easements, the Access Party shall not unreasonably disrupt or interfere with normal operation of the Granting Party's business and shall adhere to the safety rules and procedures established in advance, as may be changed from time to time, by the Granting Party and provided to the Access Party.

5.13 Lands of Other Property Owners. If any part of Transmission Provider or Transmission Owner's Interconnection Facilities and/or Network Upgrades is to be installed on property owned by persons other than Interconnection Customer or

Transmission Provider or Transmission Owner, Transmission Provider or Transmission Owner shall at Interconnection Customer's expense use efforts, similar in nature and extent to those that it typically undertakes on its own behalf or on behalf of its Affiliates, including use of its eminent domain authority, and to the extent consistent with state law, to procure from such persons any rights of use, licenses, rights of way and easements that are necessary to construct, operate, maintain, test, inspect, replace or remove Transmission Provider or Transmission Owner's Interconnection Facilities and/or Network Upgrades upon such property.

- 5.14 Permits.** The LGIA shall specify the allocation of the responsibilities of Transmission Provider or Transmission Owner and Interconnection Customer to obtain all permits, licenses and authorizations that are necessary to accomplish the interconnection in compliance with Applicable Laws and Regulations. Transmission Provider or Transmission Owner and Interconnection Customer shall cooperate with each other in good faith in obtaining any such permits, licenses and authorizations. With respect to this paragraph, Transmission Provider or Transmission Owner shall provide permitting assistance to Interconnection Customer comparable to that provided to Transmission Provider's own, or an Affiliate's generation.
- 5.15 Early Construction of Base Case Facilities.** Interconnection Customer may request Transmission Provider to construct, and Transmission Provider shall construct, using Reasonable Efforts to accommodate Interconnection Customer's In-Service Date, all or any portion of any Network Upgrades required for Interconnection Customer to be interconnected to the Transmission System which are included in the Base Case of the Facilities Study for Interconnection Customer, and which also are required to be constructed for another Interconnection Customer, but where such construction is not scheduled to be completed in time to achieve Interconnection Customer's In-Service Date.
- 5.16 Suspension.** Interconnection Customer reserves the right, upon written notice to Transmission Provider, to suspend at any time all work by Transmission Provider associated with the construction and installation of Transmission Provider's Interconnection Facilities and/or Network Upgrades required under this LGIA with the condition that Transmission System shall be left in a safe and reliable condition in accordance with Good Utility Practice and Transmission Provider's safety and reliability criteria. In such event, Interconnection Customer shall be responsible for all reasonable and necessary costs which Transmission Provider (i) has incurred pursuant to this LGIA prior to the suspension and (ii) incurs in suspending such work, including any costs incurred to perform such work as may be necessary to ensure the safety of persons and property and the integrity of the

Transmission System during such suspension and, if applicable, any costs incurred in connection with the cancellation or suspension of material, equipment and labor contracts which Transmission Provider cannot reasonably avoid; provided, however, that prior to canceling or suspending any such material, equipment or labor contract, Transmission Provider shall obtain Interconnection Customer's authorization to do so.

Transmission Provider shall invoice Interconnection Customer for such costs pursuant to Article 12 and shall use due diligence to minimize its costs. In the event Interconnection Customer suspends work by Transmission Provider required under this LGIA pursuant to this Article 5.16, and has not requested Transmission Provider to recommence the work required under this LGIA on or before the expiration of three (3) years following commencement of such suspension, this LGIA shall be deemed terminated. The three-year period shall begin on the date the suspension is requested, or the date of the written notice to Transmission Provider, if no effective date is specified.

5.17 Taxes.

5.17.1 Interconnection Customer Payments Not Taxable. The Parties intend that all payments or property transfers made by Interconnection Customer to Transmission Provider for the installation of Transmission Provider's Interconnection Facilities and the Network Upgrades shall be non-taxable, either as contributions to capital, or as an advance, in accordance with the Internal Revenue Code and any applicable state income tax laws and shall not be taxable as contributions in aid of construction or otherwise under the Internal Revenue Code and any applicable state income tax laws.

5.17.2 Representations and Covenants. In accordance with IRS Notice 2001-82 and IRS Notice 88-129, Interconnection Customer represents and covenants that (i) ownership of the electricity generated at the Large Generating Facility will pass to another party prior to the transmission of the electricity on the Transmission System, (ii) for income tax purposes, the amount of any payments and the cost of any property transferred to Transmission Provider for Transmission Provider's Interconnection Facilities will be capitalized by Interconnection Customer as an intangible asset and recovered using the straight-line method over a useful life of twenty (20) years, and (iii) any portion of Transmission Provider's Interconnection Facilities that is a "dual-use intertie," within the meaning of IRS

Notice 88-129, is reasonably expected to carry only a de minimis amount of electricity in the direction of the Large Generating Facility. For this purpose, "de minimis amount" means no more than 5 percent of the total power flows in both directions, calculated in accordance with the "5 percent test" set forth in IRS Notice 88-129. This is not intended to be an exclusive list of the relevant conditions that must be met to conform to IRS requirements for non-taxable treatment.

At Transmission Provider's request, Interconnection Customer shall provide Transmission Provider with a report from an independent engineer confirming its representation in clause (iii), above. Transmission Provider represents and covenants that the cost of Transmission Provider's Interconnection Facilities paid for by Interconnection Customer will have no net effect on the base upon which rates are determined.

5.17.3 Indemnification for the Cost Consequences of Current Tax Liability Imposed Upon the Transmission Provider.

Notwithstanding Article 5.17.1, Interconnection Customer shall protect, indemnify and hold harmless Transmission Provider from the cost consequences of any current tax liability imposed against Transmission Provider as the result of payments or property transfers made by Interconnection Customer to Transmission Provider under this LGIA for Interconnection Facilities, as well as any interest and penalties, other than interest and penalties attributable to any delay caused by Transmission Provider.

Transmission Provider shall not include a gross-up for the cost consequences of any current tax liability in the amounts it charges Interconnection Customer under this LGIA unless (i) Transmission Provider has determined, in good faith, that the payments or property transfers made by Interconnection Customer to Transmission Provider should be reported as income subject to taxation or (ii) any Governmental Authority directs Transmission Provider to report payments or property as income subject to taxation; provided, however, that Transmission Provider may require Interconnection Customer to provide security for Interconnection Facilities, in a form reasonably acceptable to Transmission Provider (such as a parental guarantee or a letter of credit), in an amount equal to the cost consequences of any current tax liability under this Article 5.17.

Interconnection Customer shall reimburse Transmission Provider for such costs on a fully grossed-up basis, in accordance with Article 5.17.4, within thirty (30) Calendar Days of receiving written notification from Transmission Provider of the amount due, including detail about how the amount was calculated.

The indemnification obligation shall terminate at the earlier of (1) the expiration of the ten year testing period and the applicable statute of limitation, as it may be extended by Transmission Provider upon request of the IRS, to keep these years open for audit or adjustment, or (2) the occurrence of a subsequent taxable event and the payment of any related indemnification obligations as contemplated by this Article 5.17.

5.17.4 Tax Gross-Up Amount. Interconnection Customer's liability for the cost consequences of any current tax liability under this Article 5.17 shall be calculated on a fully grossed-up basis. Except as may otherwise be agreed to by the parties, this means that Interconnection Customer will pay Transmission Provider, in addition to the amount paid for the Interconnection Facilities and Network Upgrades, an amount equal to (1) the current taxes imposed on Transmission Provider ("Current Taxes") on the excess of (a) the gross income realized by Transmission Provider as a result of payments or property transfers made by Interconnection Customer to Transmission Provider under this LGIA (without regard to any payments under this Article 5.17) (the "Gross Income Amount") over (b) the present value of future tax deductions for depreciation that will be available as a result of such payments or property transfers (the "Present Value Depreciation Amount"), plus (2) an additional amount sufficient to permit Transmission Provider to receive and retain, after the payment of all Current Taxes, an amount equal to the net amount described in clause (1).

For this purpose, (i) Current Taxes shall be computed based on Transmission Provider's composite federal and state tax rates at the time the payments or property transfers are received and Transmission Provider will be treated as being subject to tax at the highest marginal rates in effect at that time (the "Current Tax Rate"), and (ii) the Present Value Depreciation Amount shall be computed by discounting Transmission Provider's anticipated tax depreciation deductions as a result of such payments or property transfers by

Transmission Provider's current weighted average cost of capital. Thus, the formula for calculating Interconnection Customer's liability to Transmission Owner pursuant to this Article 5.17.4 can be expressed as follows: $(\text{Current Tax Rate} \times (\text{Gross Income Amount} - \text{Present Value of Tax Depreciation})) / (1 - \text{Current Tax Rate})$. Interconnection Customer's estimated tax liability in the event taxes are imposed shall be stated in Appendix A, Interconnection Facilities, Network Upgrades and Distribution Upgrades.

5.17.5 Private Letter Ruling or Change or Clarification of Law. At Interconnection Customer's request and expense, Transmission Provider shall file with the IRS a request for a private letter ruling as to whether any property transferred or sums paid, or to be paid, by Interconnection Customer to Transmission Provider under this LGIA are subject to federal income taxation. Interconnection Customer will prepare the initial draft of the request for a private letter ruling, and will certify under penalties of perjury that all facts represented in such request are true and accurate to the best of Interconnection Customer's knowledge. Transmission Provider and Interconnection Customer shall cooperate in good faith with respect to the submission of such request.

Transmission Provider shall keep Interconnection Customer fully informed of the status of such request for a private letter ruling and shall execute either a privacy act waiver or a limited power of attorney, in a form acceptable to the IRS, that authorizes Interconnection Customer to participate in all discussions with the IRS regarding such request for a private letter ruling. Transmission Provider shall allow Interconnection Customer to attend all meetings with IRS officials about the request and shall permit Interconnection Customer to prepare the initial drafts of any follow-up letters in connection with the request.

5.17.6 Subsequent Taxable Events. If, within 10 years from the date on which the relevant Transmission Provider's Interconnection Facilities are placed in service, (i) Interconnection Customer Breaches the covenants contained in Article 5.17.2, (ii) a "disqualification event" occurs within the meaning of IRS Notice 88-129, or (iii) this LGIA terminates and Transmission Provider retains ownership of the Interconnection Facilities and Network Upgrades, Interconnection Customer shall pay a tax gross-up for the cost consequences of any

current tax liability imposed on Transmission Provider, calculated using the methodology described in Article 5.17.4 and in accordance with IRS Notice 90-60.

5.17.7

Contests. In the event any Governmental Authority determines that Transmission Provider's receipt of payments or property constitutes income that is subject to taxation, Transmission Provider shall notify Interconnection Customer, in writing, within thirty (30) Calendar Days of receiving notification of such determination by a Governmental Authority. Upon the timely written request by Interconnection Customer and at Interconnection Customer's sole expense, Transmission Provider may appeal, protest, seek abatement of, or otherwise oppose such determination. Upon Interconnection Customer's written request and sole expense, Transmission Provider may file a claim for refund with respect to any taxes paid under this Article 5.17, whether or not it has received such a determination. Transmission Provider reserves the right to make all decisions with regard to the prosecution of such appeal, protest, abatement or other contest, including the selection of counsel and compromise or settlement of the claim, but Transmission Provider shall keep Interconnection Customer informed, shall consider in good faith suggestions from Interconnection Customer about the conduct of the contest, and shall reasonably permit Interconnection Customer or an Interconnection Customer representative to attend contest proceedings.

Interconnection Customer shall pay to Transmission Provider on a periodic basis, as invoiced by Transmission Provider, Transmission Provider's documented reasonable costs of prosecuting such appeal, protest, abatement or other contest. At any time during the contest, Transmission Provider may agree to a settlement either with Interconnection Customer's consent or after obtaining written advice from nationally-recognized tax counsel, selected by Transmission Provider, but reasonably acceptable to Interconnection Customer, that the proposed settlement represents a reasonable settlement given the hazards of litigation. Interconnection Customer's obligation shall be based on the amount of the settlement agreed to by Interconnection Customer, or if a higher amount, so much of the settlement that is supported by the written advice from nationally-recognized tax counsel selected under the terms of the preceding sentence. Any settlement without Interconnection Customer's

consent or such written advice will relieve Interconnection Customer from any obligation to indemnify Transmission Provider for the tax at issue in the contest.

5.17.8 Refund. In the event that (a) a private letter ruling is issued to Transmission Provider which holds that any amount paid or the value of any property transferred by Interconnection Customer to Transmission Provider under the terms of this LGIA is not subject to federal income taxation, (b) any legislative change or administrative announcement, notice, ruling or other determination makes it reasonably clear to Transmission Provider in good faith that any amount paid or the value of any property transferred by Interconnection Customer to Transmission Provider under the terms of this LGIA is not taxable to Transmission Provider, (c) any abatement, appeal, protest, or other contest results in a determination that any payments or transfers made by Interconnection Customer to Transmission Provider are not subject to federal income tax, or (d) if Transmission Provider receives a refund from any taxing authority for any overpayment of tax attributable to any payment or property transfer made by Interconnection Customer to Transmission Provider pursuant to this LGIA, Transmission Provider shall promptly refund to Interconnection Customer the following:

(i) any payment made by Interconnection Customer under this Article 5.17 for taxes that is attributable to the amount determined to be non-taxable, together with interest thereon,

(ii) on any amounts paid by Interconnection Customer to Transmission Provider for such taxes which Transmission Provider did not submit to the taxing authority, calculated in accordance with the methodology set forth in FERC's regulations at 18 CFR §35.19a(a)(2)(ii) from the date payment was made by Interconnection Customer to the date Transmission Provider refunds such payment to Interconnection Customer, and

(iii) with respect to any such taxes paid by Transmission Provider, any refund or credit Transmission Provider receives or to which it may be entitled from any Governmental Authority, interest (or that portion thereof attributable to the payment described in clause (i), above) owed to Transmission

Provider for such overpayment of taxes (including any reduction in interest otherwise payable by Transmission Provider to any Governmental Authority resulting from an offset or credit); provided, however, that Transmission Provider will remit such amount promptly to Interconnection Customer only after and to the extent that Transmission Provider has received a tax refund, credit or offset from any Governmental Authority for any applicable overpayment of income tax related to Transmission Provider's Interconnection Facilities.

The intent of this provision is to leave the Parties, to the extent practicable, in the event that no taxes are due with respect to any payment for Interconnection Facilities and Network Upgrades hereunder, in the same position they would have been in had no such tax payments been made.

- 5.17.9 Taxes Other Than Income Taxes.** Upon the timely request by Interconnection Customer, and at Interconnection Customer's sole expense, Transmission Provider may appeal, protest, seek abatement of, or otherwise contest any tax (other than federal or state income tax) asserted or assessed against Transmission Provider for which Interconnection Customer may be required to reimburse Transmission Provider under the terms of this LGIA. Interconnection Customer shall pay to Transmission Provider on a periodic basis, as invoiced by Transmission Provider, Transmission Provider's documented reasonable costs of prosecuting such appeal, protest, abatement, or other contest. Interconnection Customer and Transmission Provider shall cooperate in good faith with respect to any such contest. Unless the payment of such taxes is a prerequisite to an appeal or abatement or cannot be deferred, no amount shall be payable by Interconnection Customer to Transmission Provider for such taxes until they are assessed by a final, non-appealable order by any court or agency of competent jurisdiction. In the event that a tax payment is withheld and ultimately due and payable after appeal, Interconnection Customer will be responsible for all taxes, interest and penalties, other than penalties attributable to any delay caused by Transmission Provider.

- 5.17.10 Transmission Owners Who Are Not Transmission Providers.** If Transmission Provider is not the same entity as the Transmission

Owner, then (i) all references in this Article 5.17 to Transmission Provider shall be deemed also to refer to and to include the Transmission Owner, as appropriate, and (ii) this LGIA shall not become effective until such Transmission Owner shall have agreed in writing to assume all of the duties and obligations of Transmission Provider under this Article 5.17 of this LGIA.

5.18 Tax Status. Each Party shall cooperate with the other to maintain the other Party's tax status. Nothing in this LGIA is intended to adversely affect any Transmission Provider's tax exempt status with respect to the issuance of bonds including, but not limited to, Local Furnishing Bonds.

5.19 Modification.

5.19.1 General. Either Party may undertake modifications to its facilities. If a Party plans to undertake a modification that reasonably may be expected to affect the other Party's facilities, that Party shall provide to the other Party sufficient information regarding such modification so that the other Party may evaluate the potential impact of such modification prior to commencement of the work. Such information shall be deemed to be confidential hereunder and shall include information concerning the timing of such modifications and whether such modifications are expected to interrupt the flow of electricity from the Large Generating Facility. The Party desiring to perform such work shall provide the relevant drawings, plans, and specifications to the other Party at least ninety (90) Calendar Days in advance of the commencement of the work or such shorter period upon which the Parties may agree, which agreement shall not unreasonably be withheld, conditioned or delayed.

In the case of Large Generating Facility modifications that do not require Interconnection Customer to submit an Interconnection Request, Transmission Provider shall provide, within thirty (30) Calendar Days (or such other time as the Parties may agree), an estimate of any additional modifications to the Transmission System, Transmission Provider's Interconnection Facilities or Network Upgrades necessitated by such Interconnection Customer modification and a good faith estimate of the costs thereof.

5.19.2 Standards. Any additions, modifications, or replacements made to a Party's facilities shall be designed, constructed and operated in

accordance with this LGIA and Good Utility Practice.

- 5.19.3 Modification Costs.** Interconnection Customer shall not be directly assigned for the costs of any additions, modifications, or replacements that Transmission Provider makes to Transmission Provider's Interconnection Facilities or the Transmission System to facilitate the interconnection of a third party to Transmission Provider's Interconnection Facilities or the Transmission System, or to provide transmission service to a third party under Transmission Provider's Tariff. Interconnection Customer shall be responsible for the costs of any additions, modifications, or replacements to Interconnection Customer's Interconnection Facilities that may be necessary to maintain or upgrade such Interconnection Customer's Interconnection Facilities consistent with Applicable Laws and Regulations, Applicable Reliability Standards or Good Utility Practice.

Article 6. Testing and Inspection

- 6.1 Pre-Commercial Operation Date Testing and Modifications.** Prior to the Commercial Operation Date, Transmission Provider shall test Transmission Provider's Interconnection Facilities and Network Upgrades and Interconnection Customer shall test the Large Generating Facility and Interconnection Customer's Interconnection Facilities to ensure their safe and reliable operation. Similar testing may be required after initial operation. Each Party shall make any modifications to its facilities that are found to be necessary as a result of such testing. Interconnection Customer shall bear the cost of all such testing and modifications. Interconnection Customer shall generate test energy at the Large Generating Facility only if it has arranged for the delivery of such test energy.
- 6.2 Post-Commercial Operation Date Testing and Modifications.** Each Party shall at its own expense perform routine inspection and testing of its facilities and equipment in accordance with Good Utility Practice as may be necessary to ensure the continued interconnection of the Large Generating Facility with the Transmission System in a safe and reliable manner. Each Party shall have the right, upon advance written notice, to require reasonable additional testing of the other Party's facilities, at the requesting Party's expense, as may be in accordance with Good Utility Practice.
- 6.3 Right to Observe Testing.** Each Party shall notify the other Party in advance of

its performance of tests of its Interconnection Facilities. The other Party has the right, at its own expense, to observe such testing.

- 6.4 Right to Inspect.** Each Party shall have the right, but shall have no obligation to:
- (i) observe the other Party's tests and/or inspection of any of its System Protection Facilities and other protective equipment, including Power System Stabilizers;
 - (ii) review the settings of the other Party's System Protection Facilities and other protective equipment; and
 - (iii) review the other Party's maintenance records relative to the Interconnection Facilities, the System Protection Facilities and other protective equipment.
- A Party may exercise these rights from time to time as it deems necessary upon reasonable notice to the other Party. The exercise or non-exercise by a Party of any such rights shall not be construed as an endorsement or confirmation of any element or condition of the Interconnection Facilities or the System Protection Facilities or other protective equipment or the operation thereof, or as a warranty as to the fitness, safety, desirability, or reliability of same. Any information that a Party obtains through the exercise of any of its rights under this Article 6.4 shall be deemed to be Confidential Information and treated pursuant to Article 22 of this LGIA.

Article 7. Metering

- 7.1 General.** Each Party shall comply with the Applicable Reliability Council requirements. Unless otherwise agreed by the Parties, Transmission Provider shall install Metering Equipment at the Point of Interconnection prior to any operation of the Large Generating Facility and shall own, operate, test and maintain such Metering Equipment. Power flows to and from the Large Generating Facility shall be measured at or, at Transmission Provider's option, compensated to, the Point of Interconnection. Transmission Provider shall provide metering quantities, in analog and/or digital form, to Interconnection Customer upon request. Interconnection Customer shall bear all reasonable documented costs associated with the purchase, installation, operation, testing and maintenance of the Metering Equipment.
- 7.2 Check Meters.** Interconnection Customer, at its option and expense, may install and operate, on its premises and on its side of the Point of Interconnection, one or more check meters to check Transmission Provider's meters. Such check meters shall be for check purposes only and shall not be used for the measurement of power flows for purposes of this LGIA, except as provided in Article 7.4 below. The check meters shall be subject at all reasonable times to inspection and examination by Transmission Provider or its designee. The installation, operation

and maintenance thereof shall be performed entirely by Interconnection Customer in accordance with Good Utility Practice.

7.3 Standards. Transmission Provider shall install, calibrate, and test revenue quality Metering Equipment in accordance with applicable ANSI standards.

7.4 Testing of Metering Equipment. Transmission Provider shall inspect and test all Transmission Provider-owned Metering Equipment upon installation and at least once every two (2) years thereafter. If requested to do so by Interconnection Customer, Transmission Provider shall, at Interconnection Customer's expense, inspect or test Metering Equipment more frequently than every two (2) years. Transmission Provider shall give reasonable notice of the time when any inspection or test shall take place, and Interconnection Customer may have representatives present at the test or inspection. If at any time Metering Equipment is found to be inaccurate or defective, it shall be adjusted, repaired or replaced at Interconnection Customer's expense, in order to provide accurate metering, unless the inaccuracy or defect is due to Transmission Provider's failure to maintain, then Transmission Provider shall pay. If Metering Equipment fails to register, or if the measurement made by Metering Equipment during a test varies by more than two percent from the measurement made by the standard meter used in the test, Transmission Provider shall adjust the measurements by correcting all measurements for the period during which Metering Equipment was in error by using Interconnection Customer's check meters, if installed. If no such check meters are installed or if the period cannot be reasonably ascertained, the adjustment shall be for the period immediately preceding the test of the Metering Equipment equal to one-half the time from the date of the last previous test of the Metering Equipment.

7.5 Metering Data. At Interconnection Customer's expense, the metered data shall be telemetered to one or more locations designated by Transmission Provider and one or more locations designated by Interconnection Customer. Such telemetered data shall be used, under normal operating conditions, as the official measurement of the amount of energy delivered from the Large Generating Facility to the Point of Interconnection.

Article 8. Communications

8.1 Interconnection Customer Obligations. Interconnection Customer shall maintain satisfactory operating communications with Transmission Provider's Transmission System dispatcher or representative designated by Transmission

Provider. Interconnection Customer shall provide standard voice line, dedicated voice line and facsimile communications at its Large Generating Facility control room or central dispatch facility through use of either the public telephone system, or a voice communications system that does not rely on the public telephone system. Interconnection Customer shall also provide the dedicated data circuit(s) necessary to provide Interconnection Customer data to Transmission Provider as set forth in Appendix D, Security Arrangements Details. The data circuit(s) shall extend from the Large Generating Facility to the location(s) specified by Transmission Provider. Any required maintenance of such communications equipment shall be performed by Interconnection Customer. Operational communications shall be activated and maintained under, but not be limited to, the following events: system paralleling or separation, scheduled and unscheduled shutdowns, equipment clearances, and hourly and daily load data.

8.2 Remote Terminal Unit. Prior to the Initial Synchronization Date of the Large Generating Facility, a Remote Terminal Unit, or equivalent data collection and transfer equipment acceptable to the Parties, shall be installed by Interconnection Customer, or by Transmission Provider at Interconnection Customer's expense, to gather accumulated and instantaneous data to be telemetered to the location(s) designated by Transmission Provider through use of a dedicated point-to-point data circuit(s) as indicated in Article 8.1. The communication protocol for the data circuit(s) shall be specified by Transmission Provider. Instantaneous bi-directional analog real power and reactive power flow information must be telemetered directly to the location(s) specified by Transmission Provider.

Each Party will promptly advise the other Party if it detects or otherwise learns of any metering, telemetry or communications equipment errors or malfunctions that require the attention and/or correction by the other Party. The Party owning such equipment shall correct such error or malfunction as soon as reasonably feasible.

8.3 No Annexation. Any and all equipment placed on the premises of a Party shall be and remain the property of the Party providing such equipment regardless of the mode and manner of annexation or attachment to real property, unless otherwise mutually agreed by the Parties.

Article 9. Operations

9.1 General. Each Party shall comply with the Applicable Reliability Council requirements. Each Party shall provide to the other Party all information that may reasonably

be required by the other Party to comply with Applicable Laws and Regulations and Applicable Reliability Standards.

- 9.2 Control Area Notification.** At least three months before Initial Synchronization Date, Interconnection Customer shall notify Transmission Provider in writing of the Control Area in which the Large Generating Facility will be located. If Interconnection Customer elects to locate the Large Generating Facility in a Control Area other than the Control Area in which the Large Generating Facility is physically located, and if permitted to do so by the relevant transmission tariffs, all necessary arrangements, including but not limited to those set forth in Article 7 and Article 8 of this LGIA, and remote Control Area generator interchange agreements, if applicable, and the appropriate measures under such agreements, shall be executed and implemented prior to the placement of the Large Generating Facility in the other Control Area.
- 9.3 Transmission Provider Obligations.** Transmission Provider shall cause the Transmission System and Transmission Provider's Interconnection Facilities to be operated, maintained and controlled in a safe and reliable manner and in accordance with this LGIA. Transmission Provider may provide operating instructions to Interconnection Customer consistent with this LGIA and Transmission Provider's operating protocols and procedures as they may change from time to time. Transmission Provider will consider changes to its operating protocols and procedures proposed by Interconnection Customer.
- 9.4 Interconnection Customer Obligations.** Interconnection Customer shall at its own expense operate, maintain and control the Large Generating Facility and Interconnection Customer's Interconnection Facilities in a safe and reliable manner and in accordance with this LGIA. Interconnection Customer shall operate the Large Generating Facility and Interconnection Customer's Interconnection Facilities in accordance with all applicable requirements of the Control Area of which it is part, as such requirements are set forth in Appendix C, Interconnection Details, of this LGIA. Appendix C, Interconnection Details, will be modified to reflect changes to the requirements as they may change from time to time. Either Party may request that the other Party provide copies of the requirements set forth in Appendix C, Interconnection Details, of this LGIA.
- 9.5 Start-Up and Synchronization.** Consistent with the Parties' mutually acceptable procedures, Interconnection Customer is responsible for the proper synchronization of the Large Generating Facility to Transmission Provider's Transmission System.

9.6 Reactive Power.

9.6.1 Power Factor Design Criteria. Interconnection Customer shall design the Large Generating Facility to maintain a composite power delivery at continuous rated power output at the Point of Interconnection at a power factor within the range of 0.95 leading to 0.95 lagging, unless Transmission Provider has established different requirements that apply to all generators in the Control Area on a comparable basis. The requirements of this paragraph shall not apply to wind generators.

9.6.2 Voltage Schedules. Once Interconnection Customer has synchronized the Large Generating Facility with the Transmission System, Transmission Provider shall require Interconnection Customer to operate the Large Generating Facility to produce or absorb reactive power within the design limitations of the Large Generating Facility set forth in Article 9.6.1 (Power Factor Design Criteria). Transmission Provider's voltage schedules shall treat all sources of reactive power in the Control Area in an equitable and not unduly discriminatory manner. Transmission Provider shall exercise Reasonable Efforts to provide Interconnection Customer with such schedules at least one (1) day in advance, and may make changes to such schedules as necessary to maintain the reliability of the Transmission System. Interconnection Customer shall operate the Large Generating Facility to maintain the specified output voltage or power factor at the Point of Interconnection within the design limitations of the Large Generating Facility set forth in Article 9.6.1 (Power Factor Design Criteria). If Interconnection Customer is unable to maintain the specified voltage or power factor, it shall promptly notify the System Operator.

9.6.2.1 Governors and Regulators. Whenever the Large Generating Facility is operated in parallel with the Transmission System and the speed governors (if installed on the generating unit pursuant to Good Utility Practice) and voltage regulators are capable of operation, Interconnection Customer shall operate the Large Generating Facility with its speed governors and voltage regulators in automatic operation. If the Large Generating Facility's speed governors and voltage regulators are not capable of such automatic operation, Interconnection Customer shall immediately notify Transmission Provider's system operator, or its designated representative, and ensure that such Large Generating Facility's reactive power production or absorption (measured in MVARs) are within

the design capability of the Large Generating Facility's generating unit(s) and steady state stability limits. Interconnection Customer shall not cause its Large Generating Facility to disconnect automatically or instantaneously from the Transmission System or trip any generating unit comprising the Large Generating Facility for an under or over frequency condition unless the abnormal frequency condition persists for a time period beyond the limits set forth in ANSI/IEEE Standard C37.106, or such other standard as applied to other generators in the Control Area on a comparable basis.

9.6.3 Payment for Reactive Power. Transmission Provider is required to pay Interconnection Customer for reactive power that Interconnection Customer provides or absorbs from the Large Generating Facility when Transmission Provider requests Interconnection Customer to operate its Large Generating Facility outside the range specified in Article 9.6.1, provided that if Transmission Provider pays its own or affiliated generators for reactive power service within the specified range, it must also pay Interconnection Customer. Payments shall be pursuant to Article 11.6 or such other agreement to which the Parties have otherwise agreed.

9.7 Outages and Interruptions.

9.7.1 Outages.

9.7.1.1 Outage Authority and Coordination. Each Party may in accordance with Good Utility Practice in coordination with the other Party remove from service any of its respective Interconnection Facilities or Network Upgrades that may impact the other Party's facilities as necessary to perform maintenance or testing or to install or replace equipment. Absent an Emergency Condition, the Party scheduling a removal of such facility(ies) from service will use Reasonable Efforts to schedule such removal on a date and time mutually acceptable to the Parties. In all circumstances, any Party planning to remove such facility(ies) from service shall use Reasonable Efforts to minimize the effect on the other Party of such removal.

9.7.1.2 Outage Schedules. Transmission Provider shall post

scheduled outages of its transmission facilities on the OASIS. Interconnection Customer shall submit its planned maintenance schedules for the Large Generating Facility to Transmission Provider for a minimum of a rolling twenty-four month period. Interconnection Customer shall update its planned maintenance schedules as necessary. Transmission Provider may request Interconnection Customer to reschedule its maintenance as necessary to maintain the reliability of the Transmission System; provided, however, adequacy of generation supply shall not be a criterion in determining Transmission System reliability. Transmission Provider shall compensate Interconnection Customer for any additional direct costs that Interconnection Customer incurs as a result of having to reschedule maintenance, including any additional overtime, breaking of maintenance contracts or other costs above and beyond the cost Interconnection Customer would have incurred absent Transmission Provider's request to reschedule maintenance. Interconnection Customer will not be eligible to receive compensation, if during the twelve (12) months prior to the date of the scheduled maintenance, Interconnection Customer had modified its schedule of maintenance activities.

9.7.1.3 Outage Restoration. If an outage on a Party's Interconnection Facilities or Network Upgrades adversely affects the other Party's operations or facilities, the Party that owns or controls the facility that is out of service shall use Reasonable Efforts to promptly restore such facility(ies) to a normal operating condition consistent with the nature of the outage. The Party that owns or controls the facility that is out of service shall provide the other Party, to the extent such information is known, information on the nature of the Emergency Condition, an estimated time of restoration, and any corrective actions required. Initial verbal notice shall be followed up as soon as practicable with written notice explaining the nature of the outage.

9.7.2 Interruption of Service. If required by Good Utility Practice to do so, Transmission Provider may require Interconnection Customer to interrupt or reduce deliveries of electricity if such delivery of electricity could adversely affect Transmission Provider's ability to perform such activities as are

necessary to safely and reliably operate and maintain the Transmission System. The following provisions shall apply to any interruption or reduction permitted under this Article 9.7.2:

- 9.7.2.1 The interruption or reduction shall continue only for so long as reasonably necessary under Good Utility Practice;
- 9.7.2.2 Any such interruption or reduction shall be made on an equitable, non-discriminatory basis with respect to all generating facilities directly connected to the Transmission System;
- 9.7.2.3 When the interruption or reduction must be made under circumstances which do not allow for advance notice, Transmission Provider shall notify Interconnection Customer by telephone as soon as practicable of the reasons for the curtailment, interruption, or reduction, and, if known, its expected duration. Telephone notification shall be followed by written notification as soon as practicable;
- 9.7.2.4 Except during the existence of an Emergency Condition, when the interruption or reduction can be scheduled without advance notice, Transmission Provider shall notify Interconnection Customer in advance regarding the timing of such scheduling and further notify Interconnection Customer of the expected duration. Transmission Provider shall coordinate with Interconnection Customer using Good Utility Practice to schedule the interruption or reduction during periods of least impact to Interconnection Customer and Transmission Provider;
- 9.7.2.5 The Parties shall cooperate and coordinate with each other to the extent necessary in order to restore the Large Generating Facility, Interconnection Facilities, and the Transmission System to their normal operating state, consistent with system conditions and Good Utility Practice.

9.7.3 Under-Frequency and Over Frequency Conditions. The Transmission System is designed to automatically activate a load-shed program as required by the Applicable Reliability Council in the event of an under-frequency system disturbance. Interconnection Customer shall implement

under-frequency and over-frequency relay set points for the Large Generating Facility as required by the Applicable Reliability Council to ensure "ride through" capability of the Transmission System. Large Generating Facility response to frequency deviations of pre-determined magnitudes, both under-frequency and over-frequency deviations, shall be studied and coordinated with Transmission Provider in accordance with Good Utility Practice. The term "ride through" as used herein shall mean the ability of a Generating Facility to stay connected to and synchronized with the Transmission System during system disturbances within a range of under-frequency and over-frequency conditions, in accordance with Good Utility Practice.

9.7.4 System Protection and Other Control Requirements.

- 9.7.4.1 System Protection Facilities.** Interconnection Customer shall, at its expense, install, operate and maintain System Protection Facilities as a part of the Large Generating Facility or Interconnection Customer's Interconnection Facilities. Transmission Provider shall install at Interconnection Customer's expense any System Protection Facilities that may be required on Transmission Provider's Interconnection Facilities or the Transmission System as a result of the interconnection of the Large Generating Facility and Interconnection Customer's Interconnection Facilities.
- 9.7.4.2** Each Party's protection facilities shall be designed and coordinated with other systems in accordance with Good Utility Practice.
- 9.7.4.3** Each Party shall be responsible for protection of its facilities consistent with Good Utility Practice.
- 9.7.4.4** Each Party's protective relay design shall incorporate the necessary test switches to perform the tests required in Article 6. The required test switches will be placed such that they allow operation of lockout relays while preventing breaker failure schemes from operating and causing unnecessary breaker operations and/or the tripping of Interconnection Customer's units.
- 9.7.4.5** Each Party will test, operate and maintain System Protection

Facilities in accordance with Good Utility Practice.

9.7.4.6 Prior to the In-Service Date, and again prior to the Commercial Operation Date, each Party or its agent shall perform a complete calibration test and functional trip test of the System Protection Facilities. At intervals suggested by Good Utility Practice and following any apparent malfunction of the System Protection Facilities, each Party shall perform both calibration and functional trip tests of its System Protection Facilities. These tests do not require the tripping of any in-service generation unit. These tests do, however, require that all protective relays and lockout contacts be activated.

9.7.5 Requirements for Protection. In compliance with Good Utility Practice, Interconnection Customer shall provide, install, own, and maintain relays, circuit breakers and all other devices necessary to remove any fault contribution of the Large Generating Facility to any short circuit occurring on the Transmission System not otherwise isolated by Transmission Provider's equipment, such that the removal of the fault contribution shall be coordinated with the protective requirements of the Transmission System. Such protective equipment shall include, without limitation, a disconnecting device or switch with load-interrupting capability located between the Large Generating Facility and the Transmission System at a site selected upon mutual agreement (not to be unreasonably withheld, conditioned or delayed) of the Parties. Interconnection Customer shall be responsible for protection of the Large Generating Facility and Interconnection Customer's other equipment from such conditions as negative sequence currents, over- or under-frequency, sudden load rejection, over- or under-voltage, and generator loss-of-field. Interconnection Customer shall be solely responsible to disconnect the Large Generating Facility and Interconnection Customer's other equipment if conditions on the Transmission System could adversely affect the Large Generating Facility.

9.7.6 Power Quality. Neither Party's facilities shall cause excessive voltage flicker nor introduce excessive distortion to the sinusoidal voltage or current waves as defined by ANSI Standard C84.1-1989, in accordance with IEEE Standard 519, or any applicable superseding electric industry standard. In the event of a conflict between ANSI Standard C84.1-1989, or any applicable superseding electric industry standard, ANSI Standard

C84.1-1989, or the applicable superseding electric industry standard, shall control.

9.8 Switching and Tagging Rules. Each Party shall provide the other Party a copy of its switching and tagging rules that are applicable to the other Party's activities. Such switching and tagging rules shall be developed on a non-discriminatory basis. The Parties shall comply with applicable switching and tagging rules, as amended from time to time, in obtaining clearances for work or for switching operations on equipment.

9.9 Use of Interconnection Facilities by Third Parties.

9.9.1 Purpose of Interconnection Facilities. Except as may be required by Applicable Laws and Regulations, or as otherwise agreed to among the Parties, the Interconnection Facilities shall be constructed for the sole purpose of interconnecting the Large Generating Facility to the Transmission System and shall be used for no other purpose.

9.9.2 Third Party Users. If required by Applicable Laws and Regulations or if the Parties mutually agree, such agreement not to be unreasonably withheld, to allow one or more third parties to use Transmission Provider's Interconnection Facilities, or any part thereof, Interconnection Customer will be entitled to compensation for the capital expenses it incurred in connection with the Interconnection Facilities based upon the pro rata use of the Interconnection Facilities by Transmission Provider, all third party users, and Interconnection Customer, in accordance with Applicable Laws and Regulations or upon some other mutually-agreed upon methodology. In addition, cost responsibility for ongoing costs, including operation and maintenance costs associated with the Interconnection Facilities, will be allocated between Interconnection Customer and any third party users based upon the pro rata use of the Interconnection Facilities by Transmission Provider, all third party users, and Interconnection Customer, in accordance with Applicable Laws and Regulations or upon some other mutually agreed upon methodology. If the issue of such compensation or allocation cannot be resolved through such negotiations, it shall be submitted to FERC for resolution.

9.10 Disturbance Analysis Data Exchange. The Parties will cooperate with one another in the analysis of disturbances to either the Large Generating Facility or Transmission Provider's Transmission System by gathering and providing access to any information relating to any disturbance, including information from

oscillography, protective relay targets, breaker operations and sequence of events records, and any disturbance information required by Good Utility Practice.

Article 10. Maintenance

- 10.1 Transmission Provider Obligations.** Transmission Provider shall maintain the Transmission System and Transmission Provider's Interconnection Facilities in a safe and reliable manner and in accordance with this LGIA.
- 10.2 Interconnection Customer Obligations.** Interconnection Customer shall maintain the Large Generating Facility and Interconnection Customer's Interconnection Facilities in a safe and reliable manner and in accordance with this LGIA.
- 10.3 Coordination.** The Parties shall confer regularly to coordinate the planning, scheduling and performance of preventive and corrective maintenance on the Large Generating Facility and the Interconnection Facilities.
- 10.4 Secondary Systems.** Each Party shall cooperate with the other in the inspection, maintenance, and testing of control or power circuits that operate below 600 volts, AC or DC, including, but not limited to, any hardware, control or protective devices, cables, conductors, electric raceways, secondary equipment panels, transducers, batteries, chargers, and voltage and current transformers that directly affect the operation of a Party's facilities and equipment which may reasonably be expected to impact the other Party. Each Party shall provide advance notice to the other Party before undertaking any work on such circuits, especially on electrical circuits involving circuit breaker trip and close contacts, current transformers, or potential transformers.
- 10.5 Operating and Maintenance Expenses.** Subject to the provisions herein addressing the use of facilities by others, and except for operations and maintenance expenses associated with modifications made for providing interconnection or transmission service to a third party and such third party pays for such expenses, Interconnection Customer shall be responsible for all reasonable expenses including overheads, associated with: (1) owning, operating, maintaining, repairing, and replacing Interconnection Customer's Interconnection Facilities; and (2) operation, maintenance, repair and replacement of Transmission Provider's Interconnection Facilities.

Article 11. Performance Obligation

- 11.1 Interconnection Customer Interconnection Facilities.** Interconnection Customer shall design, procure, construct, install, own and/or control Interconnection Customer Interconnection Facilities described in Appendix A, Interconnection Facilities, Network Upgrades and Distribution Upgrades, at its sole expense.
- 11.2 Transmission Provider's Interconnection Facilities.** Transmission Provider or Transmission Owner shall design, procure, construct, install, own and/or control the Transmission Provider's Interconnection Facilities described in Appendix A, Interconnection Facilities, Network Upgrades and Distribution Upgrades, at the sole expense of the Interconnection Customer.
- 11.3 Network Upgrades and Distribution Upgrades.** Transmission Provider or Transmission Owner shall design, procure, construct, install, and own the Network Upgrades and Distribution Upgrades described in Appendix A, Interconnection Facilities, Network Upgrades and Distribution Upgrades. The Interconnection Customer shall be responsible for all costs related to Distribution Upgrades. Unless Transmission Provider or Transmission Owner elects to fund the capital for the Network Upgrades, they shall be solely funded by Interconnection Customer.
- 11.4 Transmission Credits.**
- 11.4.1 Repayment of Amounts Advanced for Network Upgrades.**
Interconnection Customer shall be entitled to a cash repayment, equal to the total amount paid to Transmission Provider and Affected System Operator, if any, for the Network Upgrades, including any tax gross-up or other tax-related payments associated with Network Upgrades, and not refunded to Interconnection Customer pursuant to Article 5.17.8 or otherwise, to be paid to Interconnection Customer on a dollar-for-dollar basis for the non-usage sensitive portion of transmission charges, as payments are made under Transmission Provider's Tariff and Affected System's Tariff for transmission services with respect to the Large Generating Facility. Any repayment shall include interest calculated in accordance with the methodology set forth in FERC's regulations at 18 C.F.R. § 35.19a(a)(2)(ii) from the date of any payment for Network Upgrades through the date on which the Interconnection Customer

receives a repayment of such payment pursuant to this subparagraph. Interconnection Customer may assign such repayment rights to any person.

Notwithstanding the foregoing, Interconnection Customer, Transmission Provider, and Affected System Operator may adopt any alternative payment schedule that is mutually agreeable so long as Transmission Provider and Affected System Operator take one of the following actions no later than five years from the Commercial Operation Date: (1) return to Interconnection Customer any amounts advanced for Network Upgrades not previously repaid, or (2) declare in writing that Transmission Provider or Affected System Operator will continue to provide payments to Interconnection Customer pursuant to this subparagraph until all amounts advanced for Network Upgrades have been repaid.

If the Large Generating Facility fails to achieve commercial operation, but it or another Generating Facility is later constructed and makes use of the Network Upgrades, Transmission Provider and Affected System Operator shall at that time reimburse Interconnection Customer for the amounts advanced for the Network Upgrades.

11.4.2 Special Provisions for Affected Systems. Unless Transmission Provider provides, under the LGIA, for the repayment of amounts advanced to Affected System Operator for Network Upgrades, Interconnection Customer and Affected System Operator shall enter into an agreement that provides for such repayment. The agreement shall specify the terms governing payments to be made by Interconnection Customer to the Affected System Operator as well as the repayment by the Affected System Operator.

11.4.3 Notwithstanding any other provision of this LGIA, nothing herein shall be construed as relinquishing or foreclosing any rights, including but not limited to firm transmission rights, capacity rights, transmission congestion rights, or transmission credits, that Interconnection Customer, shall be entitled to, now or in the future under any other agreement or tariff as a result of, or otherwise associated with, the transmission capacity, if any, created by the Network Upgrades, including the right to obtain cash reimbursements or transmission

credits for transmission service that is not associated with the Large Generating Facility.

11.5 Provision of Security. At least thirty (30) Calendar Days prior to the commencement of the procurement, installation, or construction of a discrete portion of a Transmission Provider's Interconnection Facilities, Network Upgrades, or Distribution Upgrades, Interconnection Customer shall provide Transmission Provider, at Interconnection Customer's option, a guarantee, a surety bond, letter of credit or other form of security that is reasonably acceptable to Transmission Provider and is consistent with the Uniform Commercial Code of the jurisdiction identified in Article 14.2.1. Such security for payment shall be in an amount sufficient to cover the costs for constructing, procuring and installing the applicable portion of Transmission Provider's Interconnection Facilities, Network Upgrades, or Distribution Upgrades and shall be reduced on a dollar-for-dollar basis for payments made to Transmission Provider for these purposes.

In addition:

11.5.1 The guarantee must be made by an entity that meets the creditworthiness requirements of Transmission Provider, and contain terms and conditions that guarantee payment of any amount that may be due from Interconnection Customer, up to an agreed-to maximum amount.

11.5.2 The letter of credit must be issued by a financial institution reasonably acceptable to Transmission Provider and must specify a reasonable expiration date.

11.5.3 The surety bond must be issued by an insurer reasonably acceptable to Transmission Provider and must specify a reasonable expiration date.

11.6 Interconnection Customer Compensation. If Transmission Provider requests or directs Interconnection Customer to provide a service pursuant to Articles 9.6.3 (Payment for Reactive Power), or 13.5.1 of this LGIA, Transmission Provider shall compensate Interconnection Customer in accordance with Interconnection Customer's applicable rate schedule then in effect unless the provision of such service(s) is subject to an RTO or ISO FERC-approved rate schedule. Interconnection Customer shall serve Transmission Provider or RTO or ISO with any filing of a proposed rate schedule at the time of such filing with FERC. To the extent that no rate schedule is in effect at the time the Interconnection Customer is required to provide or absorb any Reactive Power under this LGIA, Transmission

Provider agrees to compensate Interconnection Customer in such amount as would have been due Interconnection Customer had the rate schedule been in effect at the time service commenced; provided, however, that such rate schedule must be filed at FERC or other appropriate Governmental Authority within sixty (60) Calendar Days of the commencement of service.

11.6.1 Interconnection Customer Compensation for Actions During

Emergency Condition. Transmission Provider or RTO or ISO shall compensate Interconnection Customer for its provision of real and reactive power and other Emergency Condition services that Interconnection Customer provides to support the Transmission System during an Emergency Condition in accordance with Article 11.6.

Article 12. Invoice

12.1 General. Each Party shall submit to the other Party, on a monthly basis, invoices of amounts due for the preceding month. Each invoice shall state the month to which the invoice applies and fully describe the services and equipment provided. The Parties may discharge mutual debts and payment obligations due and owing to each other on the same date through netting, in which case all amounts a Party owes to the other Party under this LGIA, including interest payments or credits, shall be netted so that only the net amount remaining due shall be paid by the owing Party.

12.2 Final Invoice. Within six months after completion of the construction of Transmission Provider's Interconnection Facilities and the Network Upgrades, Transmission Provider shall provide an invoice of the final cost of the construction of Transmission Provider's Interconnection Facilities and the Network Upgrades and shall set forth such costs in sufficient detail to enable Interconnection Customer to compare the actual costs with the estimates and to ascertain deviations, if any, from the cost estimates. Transmission Provider shall refund to Interconnection Customer any amount by which the actual payment by Interconnection Customer for estimated costs exceeds the actual costs of construction within thirty (30) Calendar Days of the issuance of such final construction invoice.

12.3 Payment. Invoices shall be rendered to the paying Party at the address specified in Appendix F. The Party receiving the invoice shall pay the invoice within thirty (30) Calendar Days of receipt. All payments shall be made in immediately available funds payable to the other Party, or by wire transfer to a bank named and

account designated by the invoicing Party. Payment of invoices by either Party will not constitute a waiver of any rights or claims either Party may have under this LGIA.

12.4 Disputes. In the event of a billing dispute between Transmission Provider and Interconnection Customer, Transmission Provider shall continue to provide Interconnection Service under this LGIA as long as Interconnection Customer: (i) continues to make all payments not in dispute; and (ii) pays to Transmission Provider or into an independent escrow account the portion of the invoice in dispute, pending resolution of such dispute. If Interconnection Customer fails to meet these two requirements for continuation of service, then Transmission Provider may provide notice to Interconnection Customer of a Default pursuant to Article 17. Within thirty (30) Calendar Days after the resolution of the dispute, the Party that owes money to the other Party shall pay the amount due with interest calculated in accord with the methodology set forth in FERC's regulations at 18 CFR § 35.19a(a)(2)(ii).

Article 13. Emergencies

13.1 Definition. "Emergency Condition" shall mean a condition or situation: (i) that in the judgment of the Party making the claim is imminently likely to endanger life or property; or (ii) that, in the case of Transmission Provider, is imminently likely (as determined in a non-discriminatory manner) to cause a material adverse effect on the security of, or damage to the Transmission System, Transmission Provider's Interconnection Facilities or the Transmission Systems of others to which the Transmission System is directly connected; or (iii) that, in the case of Interconnection Customer, is imminently likely (as determined in a non-discriminatory manner) to cause a material adverse effect on the security of, or damage to, the Large Generating Facility or Interconnection Customer's Interconnection Facilities' System restoration and black start shall be considered Emergency Conditions; provided, that Interconnection Customer is not obligated by this LGIA to possess black start capability.

13.2 Obligations. Each Party shall comply with the Emergency Condition procedures of the applicable ISO/RTO, NERC, the Applicable Reliability Council, Applicable Laws and Regulations, and any emergency procedures agreed to by the Joint Operating Committee.

13.3 Notice. Transmission Provider shall notify Interconnection Customer promptly when it becomes aware of an Emergency Condition that affects Transmission Provider's Interconnection Facilities or the Transmission System that may

reasonably be expected to affect Interconnection Customer's operation of the Large Generating Facility or Interconnection Customer's Interconnection Facilities. Interconnection Customer shall notify Transmission Provider promptly when it becomes aware of an Emergency Condition that affects the Large Generating Facility or Interconnection Customer's Interconnection Facilities that may reasonably be expected to affect the Transmission System or Transmission Provider's Interconnection Facilities. To the extent information is known, the notification shall describe the Emergency Condition, the extent of the damage or deficiency, the expected effect on the operation of Interconnection Customer's or Transmission Provider's facilities and operations, its anticipated duration and the corrective action taken and/or to be taken. The initial notice shall be followed as soon as practicable with written notice.

13.4 Immediate Action. Unless, in Interconnection Customer's reasonable judgment, immediate action is required, Interconnection Customer shall obtain the consent of Transmission Provider, such consent to not be unreasonably withheld, prior to performing any manual switching operations at the Large Generating Facility or Interconnection Customer's Interconnection Facilities in response to an Emergency Condition either declared by Transmission Provider or otherwise regarding the Transmission System.

13.5 Transmission Provider Authority.

13.5.1 General. Transmission Provider may take whatever actions or inactions with regard to the Transmission System or Transmission Provider's Interconnection Facilities it deems necessary during an Emergency Condition in order to (i) preserve public health and safety, (ii) preserve the reliability of the Transmission System or Transmission Provider's Interconnection Facilities, (iii) limit or prevent damage, and (iv) expedite restoration of service.

Transmission Provider shall use Reasonable Efforts to minimize the effect of such actions or inactions on the Large Generating Facility or Interconnection Customer's Interconnection Facilities. Transmission Provider may, on the basis of technical considerations, require the Large Generating Facility to mitigate an Emergency Condition by taking actions necessary and limited in scope to remedy the Emergency Condition, including, but not limited to, directing Interconnection Customer to shut-down, start-up, increase or decrease the real or reactive power output of the Large Generating Facility; implementing a reduction or disconnection pursuant to

Article 13.5.2; directing Interconnection Customer to assist with blackstart (if available) or restoration efforts; or altering the outage schedules of the Large Generating Facility and Interconnection Customer's Interconnection Facilities. Interconnection Customer shall comply with all of Transmission Provider's operating instructions concerning Large Generating Facility real power and reactive power output within the manufacturer's design limitations of the Large Generating Facility's equipment that is in service and physically available for operation at the time, in compliance with Applicable Laws and Regulations.

13.5.2 Reduction and Disconnection. Transmission Provider may reduce Interconnection Service or disconnect the Large Generating Facility or Interconnection Customer's Interconnection Facilities, when such, reduction or disconnection is necessary under Good Utility Practice due to Emergency Conditions. These rights are separate and distinct from any right of curtailment of Transmission Provider pursuant to Transmission Provider's Tariff. When Transmission Provider can schedule the reduction or disconnection in advance, Transmission Provider shall notify Interconnection Customer of the reasons, timing and expected duration of the reduction or disconnection. Transmission Provider shall coordinate with Interconnection Customer using Good Utility Practice to schedule the reduction or disconnection during periods of least impact to Interconnection Customer and Transmission Provider. Any reduction or disconnection shall continue only for so long as reasonably necessary under Good Utility Practice. The Parties shall cooperate with each other to restore the Large Generating Facility, the Interconnection Facilities, and the Transmission System to their normal operating state as soon as practicable consistent with Good Utility Practice.

13.6 Interconnection Customer Authority. Consistent with Good Utility Practice and the LGIA and the LGIP, Interconnection Customer may take actions or inactions with regard to the Large Generating Facility or Interconnection Customer's Interconnection Facilities during an Emergency Condition in order to (i) preserve public health and safety, (ii) preserve the reliability of the Large Generating Facility or Interconnection Customer's Interconnection Facilities, (iii) limit or prevent damage, and (iv) expedite restoration of service. Interconnection Customer shall use Reasonable Efforts to minimize the effect of such actions or inactions on the Transmission System and Transmission Provider's Interconnection Facilities. Transmission Provider shall use Reasonable Efforts to assist

Interconnection Customer in such actions.

13.7 Limited Liability. Except as otherwise provided in Article 11.6.1 of this LGIA, neither Party shall be liable to the other for any action it takes in responding to an Emergency Condition so long as such action is made in good faith and is consistent with Good Utility Practice.

Article 14. Regulatory Requirements and Governing Law

14.1 Regulatory Requirements. Each Party's obligations under this LGIA shall be subject to its receipt of any required approval or certificate from one or more Governmental Authorities in the form and substance satisfactory to the applying Party, or the Party making any required filings with, or providing notice to, such Governmental Authorities, and the expiration of any time period associated therewith. Each Party shall in good faith seek and use its Reasonable Efforts to obtain such other approvals. Nothing in this LGIA shall require Interconnection Customer to take any action that could result in its inability to obtain, or its loss of, status or exemption under the Federal Power Act, the Public Utility Holding Company Act of 1935, as amended, or the Public Utility Regulatory Policies Act of 1978.

14.2 Governing Law.

14.2.1 The validity, interpretation and performance of this LGIA and each of its provisions shall be governed by the laws of the state where the Point of Interconnection is located, without regard to its conflicts of law principles.

14.2.2 This LGIA is subject to all Applicable Laws and Regulations.

14.2.3 Each Party expressly reserves the right to seek changes in, appeal, or otherwise contest any laws, orders, rules, or regulations of a Governmental Authority.

Article 15. Notices.

15.1 General. Unless otherwise provided in this LGIA, any notice, demand or request required or permitted to be given by either Party to the other and any instrument required or permitted to be tendered or delivered by either Party in writing to the other shall be effective when delivered and may be so given, tendered or delivered,

by recognized national courier, or by depositing the same with the United States Postal Service with postage prepaid, for delivery by certified or registered mail, addressed to the Party, or personally delivered to the Party, at the address set out in Appendix F, Addresses for Delivery of Notices and Billings.

Either Party may change the notice information in this LGIA by giving five (5) Business Days written notice prior to the effective date of the change.

15.2 Billings and Payments. Billings and payments shall be sent to the addresses set out in Appendix F.

15.3 Alternative Forms of Notice. Any notice or request required or permitted to be given by a Party to the other and not required by this Agreement to be given in writing may be so given by telephone, facsimile or email to the telephone numbers and email addresses set out in Appendix F.

15.4 Operations and Maintenance Notice . Each Party shall notify the other Party in writing of the identity of the person(s) that it designates as the point(s) of contact with respect to the implementation of Articles 9 and 10.

Article 16. Force Majeure

16.1 Force Majeure.

16.1.1 Economic hardship is not considered a Force Majeure event.

16.1.2 Neither Party shall be considered to be in Default with respect to any obligation hereunder, (including obligations under Article 4), other than the obligation to pay money when due, if prevented from fulfilling such obligation by Force Majeure. A Party unable to fulfill any obligation hereunder (other than an obligation to pay money when due) by reason of Force Majeure shall give notice and the full particulars of such Force Majeure to the other Party in writing or by

telephone as soon as reasonably possible after the occurrence of the cause relied upon. Telephone notices given pursuant to this article shall be confirmed in writing as soon as reasonably possible and shall specifically state full particulars of the Force Majeure, the time and date when the Force Majeure occurred and when the Force Majeure is reasonably expected to cease. The Party affected shall exercise due diligence to remove such disability with reasonable dispatch, but shall not be required to accede or agree to any provision not satisfactory to it in order to settle and terminate a strike or other labor disturbance.

Article 17. Default

17.1 Default

17.1.1 General. No Default shall exist where such failure to discharge an obligation (other than the payment of money) is the result of Force Majeure as defined in this LGIA or the result of an act of omission of the other Party. Upon a Breach, the non-breaching Party shall give written notice of such Breach to the breaching Party. Except as provided in Article 17.1.2, the breaching Party shall have thirty (30) Calendar Days from receipt of the Default notice within which to cure such Breach; provided however, if such Breach is not capable of cure within thirty (30) Calendar Days, the breaching Party shall commence such cure within thirty (30) Calendar Days after notice and continuously and diligently complete such cure within ninety (90) Calendar Days from receipt of the Default notice; and, if cured within such time, the Breach specified in such notice shall cease to exist.

17.1.2 Right to Terminate. If a Breach is not cured as provided in this article, or if a Breach is not capable of being cured within the period provided for herein, the non-breaching Party shall have the right to declare a Default and terminate this LGIA by written notice at any time until cure occurs, and be relieved of any further obligation hereunder and, whether or not that Party terminates this LGIA, to recover from the breaching Party all amounts due hereunder, plus all other damages and remedies to which it is entitled at law or in equity. The provisions of this article will survive termination of this LGIA.

Article 18. Indemnity, Consequential Damages and Insurance

18.1 Indemnity. The Parties shall at all times indemnify, defend, and hold the other Party harmless from, any and all damages, losses, claims, including claims and actions relating to injury to or death of any person or damage to property, demand, suits, recoveries, costs and expenses, court costs, attorney fees, and all other obligations by or to third parties, arising out of or resulting from the other Party's action or inactions of its obligations under this LGIA on behalf of the indemnifying Party, except in cases of gross negligence or intentional wrongdoing by the indemnified Party.

18.1.1 Indemnified Person. If an Indemnified Person is entitled to indemnification under this Article 18 as a result of a claim by a third party, and the indemnifying Party fails, after notice and reasonable opportunity to proceed under Article 18.1, to assume the defense of such claim, such Indemnified Person may at the expense of the indemnifying Party contest, settle or consent to the entry of any judgment with respect to, or pay in full, such claim.

18.1.2 Indemnifying Party. If an Indemnifying Party is obligated to indemnify and hold any Indemnified Person harmless under this Article 18, the amount owing to the Indemnified Person shall be the amount of such Indemnified Person's actual Loss, net of any insurance or other recovery.

18.1.3 Indemnity Procedures. Promptly after receipt by an Indemnified Person of any claim or notice of the commencement of any action or administrative or legal proceeding or investigation as to which the indemnity provided for in Article 18.1 may apply, the Indemnified Person shall notify the Indemnifying Party of such fact. Any failure of or delay in such notification shall not affect a Party's indemnification obligation unless such failure or delay is materially prejudicial to the indemnifying Party.

The Indemnifying Party shall have the right to assume the defense thereof with counsel designated by such Indemnifying Party and reasonably satisfactory to the Indemnified Person. If the defendants in any such action include one or more Indemnified Persons and the Indemnifying Party and if the Indemnified Person reasonably

concludes that there may be legal defenses available to it and/or other Indemnified Persons which are different from or additional to those available to the Indemnifying Party, the Indemnified Person shall have the right to select separate counsel to assert such legal defenses and to otherwise participate in the defense of such action on its own behalf. In such instances, the Indemnifying Party shall only be required to pay the fees and expenses of one additional attorney to represent an Indemnified Person or Indemnified Persons having such differing or additional legal defenses.

The Indemnified Person shall be entitled, at its expense, to participate in any such action, suit or proceeding, the defense of which has been assumed by the Indemnifying Party.

Notwithstanding the foregoing, the Indemnifying Party (i) shall not be entitled to assume and control the defense of any such action, suit or proceedings if and to the extent that, in the opinion of the Indemnified Person and its counsel, such action, suit or proceeding involves the potential imposition of criminal liability on the Indemnified Person, or there exists a conflict or adversity of interest between the Indemnified Person and the Indemnifying Party, in such event the Indemnifying Party shall pay the reasonable expenses of the Indemnified Person, and (ii) shall not settle or consent to the entry of any judgment in any action, suit or proceeding without the consent of the Indemnified Person, which shall not be reasonably withheld, conditioned or delayed.

18.2 Consequential Damages. Other than the Liquidated Damages heretofore described, in no event shall either Party be liable under any provision of this LGIA for any losses, damages, costs or expenses for any special, indirect, incidental, consequential, or punitive damages, including but not limited to loss of profit or revenue, loss of the use of equipment, cost of capital, cost of temporary equipment or services, whether based in whole or in part in contract, in tort, including negligence, strict liability, or any other theory of liability; provided, however, that damages for which a Party may be liable to the other Party under another agreement will not be considered to be special, indirect, incidental, or consequential damages hereunder.

18.3 Insurance. Each party shall, at its own expense, maintain in force throughout the period of this LGIA, and until released by the other Party, the following minimum insurance coverages, with insurers authorized to do business in the state where the Point of Interconnection is located:

- 18.3.1** Employers' Liability and Workers' Compensation Insurance providing statutory benefits in accordance with the laws and regulations of the state in which the Point of Interconnection is located.
- 18.3.2** Commercial General Liability Insurance including premises and operations, personal injury, broad form property damage, broad form blanket contractual liability coverage (including coverage for the contractual indemnification) products and completed operations coverage, coverage for explosion, collapse and underground hazards, independent contractors coverage, coverage for pollution to the extent normally available and punitive damages to the extent normally available and a cross liability endorsement, with minimum limits of One Million Dollars (\$1,000,000) per occurrence/One Million Dollars (\$1,000,000) aggregate combined single limit for personal injury, bodily injury, including death and property damage.
- 18.3.3** Comprehensive Automobile Liability Insurance for coverage of owned and non-owned and hired vehicles, trailers or semi-trailers designed for travel on public roads, with a minimum, combined single limit of One Million Dollars (\$1,000,000) per occurrence for bodily injury, including death, and property damage.
- 18.3.4** Excess Public Liability Insurance over and above the Employers' Liability Commercial General Liability and Comprehensive Automobile Liability Insurance coverage, with a minimum combined single limit of Twenty Million Dollars (\$20,000,000) per occurrence/Twenty Million Dollars (\$20,000,000) aggregate.
- 18.3.5** The Commercial General Liability Insurance, Comprehensive Automobile Insurance and Excess Public Liability Insurance policies shall name the other Party, its parent, associated and Affiliate companies and their respective directors, officers, agents, servants and employees ("Other Party Group") as additional insured. All policies shall contain provisions whereby the insurers waive all rights of subrogation in accordance with the provisions of this LGIA against the Other Party Group and provide thirty (30) days advance written notice to the Other Party Group prior to anniversary date of cancellation or any material change in coverage or condition.

- 18.3.6** The Commercial General Liability Insurance, Comprehensive Automobile Liability Insurance and Excess Public Liability Insurance policies shall contain provisions that specify that the policies are primary and shall apply to such extent without consideration for other policies separately carried and shall state that each insured is provided coverage as though a separate policy had been issued to each, except the insurer's liability shall not be increased beyond the amount for which the insurer would have been liable had only one insured been covered. Each Party shall be responsible for its respective deductibles or retentions.
- 18.3.7** The Commercial General Liability Insurance, Comprehensive Automobile Liability Insurance and Excess Public Liability Insurance policies, if written on a Claims First Made Basis, shall be maintained in full force and effect for two (2) years after termination of this LGIA, which coverage may be in the form of tail coverage or extended reporting period coverage if agreed by the Parties.
- 18.3.8** The requirements contained herein as to the types and limits of all insurance to be maintained by the Parties are not intended to and shall not in any manner, limit or qualify the liabilities and obligations assumed by the Parties under this LGIA.
- 18.3.9** Within ten (10) days following execution of this LGIA, and as soon as practicable after the end of each fiscal year or at the renewal of the insurance policy and in any event within ninety (90) days thereafter, each Party shall provide certification of all insurance required in this LGIA, executed by each insurer or by an authorized representative of each insurer.
- 18.3.10** Notwithstanding the foregoing, each Party may self-insure to meet the minimum insurance requirements of Articles 18.3.2 through 18.3.8 to the extent it maintains a self-insurance program; provided that, such Party's senior secured debt is rated at investment grade or better by Standard & Poor's and that its self-insurance program meets the minimum insurance requirements of Articles 18.3.2 through 18.3.8. For any period of time that a Party's senior secured debt is unrated by Standard & Poor's or is rated at less than investment grade by Standard & Poor's, such Party shall comply with the insurance requirements applicable to it under Articles 18.3.2 through 18.3.9. In the event that a Party is permitted to self-insure pursuant

to this article, it shall notify the other Party that it meets the requirements to self-insure and that its self-insurance program meets the minimum insurance requirements in a manner consistent with that specified in Article 18.3.9.

18.3.11 The Parties agree to report to each other in writing as soon as practical all accidents or occurrences resulting in injuries to any person, including death, and any property damage arising out of this LGIA.

Article 19. Assignment

19.1 Assignment. This LGIA may be assigned by either Party only with the written consent of the other; provided that either Party may assign this LGIA without the consent of the other Party to any Affiliate of the assigning Party with an equal or greater credit rating and with the legal authority and operational ability to satisfy the obligations of the assigning Party under this LGIA; and provided further that Interconnection Customer shall have the right to assign this LGIA, without the consent of Transmission Provider, for collateral security purposes to aid in providing financing for the Large Generating Facility, provided that Interconnection Customer will promptly notify Transmission Provider of any such assignment. Any financing arrangement entered into by Interconnection Customer pursuant to this article will provide that prior to or upon the exercise of the secured party's, trustee's or mortgagee's assignment rights pursuant to said arrangement, the secured creditor, the trustee or mortgagee will notify Transmission Provider of the date and particulars of any such exercise of assignment right(s), including providing the Transmission Provider with proof that it meets the requirements of Articles 11.5 and 18.3. Any attempted assignment that violates this article is void and ineffective. Any assignment under this LGIA shall not relieve a Party of its obligations, nor shall a Party's obligations be enlarged, in whole or in part, by reason thereof. Where required, consent to assignment will not be unreasonably withheld, conditioned or delayed.

Article 20. Severability

20.1 Severability. If any provision in this LGIA is finally determined to be invalid, void or unenforceable by any court or other Governmental Authority having jurisdiction, such determination shall not invalidate, void or make unenforceable any other provision, agreement or covenant of this LGIA; provided that if

Interconnection Customer (or any third party, but only if such third party is not acting at the direction of Transmission Provider) seeks and obtains such a final determination with respect to any provision of the Alternate Option (Article 5.1.2), or the Negotiated Option (Article 5.1.4), then none of these provisions shall thereafter have any force or effect and the Parties' rights and obligations shall be governed solely by the Standard Option (Article 5.1.1).

Article 21. Comparability

21.1 Comparability. The Parties will comply with all applicable comparability and code of conduct laws, rules and regulations, as amended from time to time.

Article 22. Confidentiality

22.1 Confidentiality. Confidential Information shall include, without limitation, all information relating to a Party's technology, research and development, business affairs, and pricing, and any information supplied by either of the Parties to the other prior to the execution of this LGIA.

Information is Confidential Information only if it is clearly designated or marked in writing as confidential on the face of the document, or, if the information is conveyed orally or by inspection, if the Party providing the information orally informs the Party receiving the information that the information is confidential.

If requested by either Party, the other Party shall provide in writing, the basis for asserting that the information referred to in this Article 22 warrants confidential treatment, and the requesting Party may disclose such writing to the appropriate Governmental Authority. Each Party shall be responsible for the costs associated with affording confidential treatment to its information.

22.1.1 Term. During the term of this LGIA, and for a period of three (3) years after the expiration or termination of this LGIA, except as otherwise provided in this Article 22, each Party shall hold in confidence and shall not disclose to any person Confidential Information.

22.1.2 Scope. Confidential Information shall not include information that the receiving Party can demonstrate: (1) is generally available to the public other than as a result of a disclosure by the receiving Party;

(2) was in the lawful possession of the receiving Party on a non-confidential basis before receiving it from the disclosing Party; (3) was supplied to the receiving Party without restriction by a third party, who, to the knowledge of the receiving Party after due inquiry, was under no obligation to the disclosing Party to keep such information confidential; (4) was independently developed by the receiving Party without reference to Confidential Information of the disclosing Party; (5) is, or becomes, publicly known, through no wrongful act or omission of the receiving Party or Breach of this LGIA; or (6) is required, in accordance with Article 22.1.7 of the LGIA, Order of Disclosure, to be disclosed by any Governmental Authority or is otherwise required to be disclosed by law or subpoena, or is necessary in any legal proceeding establishing rights and obligations under this LGIA. Information designated as Confidential Information will no longer be deemed confidential if the Party that designated the information as confidential notifies the other Party that it no longer is confidential.

22.1.3 Release of Confidential Information. Neither Party shall release or disclose Confidential Information to any other person, except to its Affiliates (limited by the Standards of Conduct requirements), subcontractors, employees, consultants, or to parties who may be or considering providing financing to or equity participation with Interconnection Customer, or to potential purchasers or assignees of Interconnection Customer, on a need-to-know basis in connection with this LGIA, unless such person has first been advised of the confidentiality provisions of this Article 22 and has agreed to comply with such provisions. Notwithstanding the foregoing, a Party providing Confidential Information to any person shall remain primarily responsible for any release of Confidential Information in contravention of this Article 22.

22.1.4 Rights. Each Party retains all rights, title, and interest in the Confidential Information that each Party discloses to the other Party. The disclosure by each Party to the other Party of Confidential Information shall not be deemed a waiver by either Party or any other person or entity of the right to protect the Confidential Information from public disclosure.

22.1.5 No Warranties. By providing Confidential Information, neither Party makes any warranties or representations as to its accuracy or

completeness. In addition, by supplying Confidential Information, neither Party obligates itself to provide any particular information or Confidential Information to the other Party nor to enter into any further agreements or proceed with any other relationship or joint venture.

- 22.1.6 Standard of Care.** Each Party shall use at least the same standard of care to protect Confidential Information it receives as it uses to protect its own Confidential Information from unauthorized disclosure, publication or dissemination. Each Party may use Confidential Information solely to fulfill its obligations to the other Party under this LGIA or its regulatory requirements.
- 22.1.7 Order of Disclosure.** If a court or a Government Authority or entity with the right, power, and apparent authority to do so requests or requires either Party, by subpoena, oral deposition, interrogatories, requests for production of documents, administrative order, or otherwise, to disclose Confidential Information, that Party shall provide the other Party with prompt notice of such request(s) or requirement(s) so that the other Party may seek an appropriate protective order or waive compliance with the terms of this LGIA. Notwithstanding the absence of a protective order or waiver, the Party may disclose such Confidential Information which, in the opinion of its counsel, the Party is legally compelled to disclose. Each Party will use Reasonable Efforts to obtain reliable assurance that confidential treatment will be accorded any Confidential Information so furnished.
- 22.1.8 Termination of Agreement.** Upon termination of this LGIA for any reason, each Party shall, within ten (10) Calendar Days of receipt of a written request from the other Party, use Reasonable Efforts to destroy, erase, or delete (with such destruction, erasure, and deletion certified in writing to the other Party) or return to the other Party, without retaining copies thereof, any and all written or electronic Confidential Information received from the other Party.
- 22.1.9 Remedies.** The Parties agree that monetary damages would be inadequate to compensate a Party for the other Party's Breach of its obligations under this Article 22. Each Party accordingly agrees that the other Party shall be entitled to equitable relief, by way of injunction or otherwise, if the first Party Breaches or threatens to

Breach its obligations under this Article 22, which equitable relief shall be granted without bond or proof of damages, and the receiving Party shall not plead in defense that there would be an adequate remedy at law. Such remedy shall not be deemed an exclusive remedy for the Breach of this Article 22, but shall be in addition to all other remedies available at law or in equity. The Parties further acknowledge and agree that the covenants contained herein are necessary for the protection of legitimate business interests and are reasonable in scope. No Party, however, shall be liable for indirect, incidental, or consequential or punitive damages of any nature or kind resulting from or arising in connection with this Article 22.

22.1.10 Disclosure to FERC, its Staff, or a State. Notwithstanding anything in this Article 22 to the contrary, and pursuant to 18 CFR section 1b.20, if FERC or its staff, during the course of an investigation or otherwise, requests information from one of the Parties that is otherwise required to be maintained in confidence pursuant to this LGIA, the Party shall provide the requested information to FERC or its staff, within the time provided for in the request for information. In providing the information to FERC or its staff, the Party must, consistent with 18 CFR section 388.112, request that the information be treated as confidential and non-public by FERC and its staff and that the information be withheld from public disclosure. Parties are prohibited from notifying the other Party to this LGIA prior to the release of the Confidential Information to FERC or its staff. The Party shall notify the other Party to the LGIA when it is notified by FERC or its staff that a request to release Confidential Information has been received by FERC, at which time either of the Parties may respond before such information would be made public, pursuant to 18 CFR section 388.112. Requests from a state regulatory body conducting a confidential investigation shall be treated in a similar manner, consistent with the applicable state rules and regulations.

22.1.11 Subject to the exception in Article 22.1.10, any information that a Party claims is competitively sensitive, commercial or financial information under this LGIA ("Confidential Information") shall not be disclosed by the other Party to any person not employed or retained by the other Party, except to the extent disclosure is (i) required by law; (ii) reasonably deemed by the disclosing Party to be required to be disclosed in connection with a dispute between or

among the Parties, or the defense of litigation or dispute; (iii) otherwise permitted by consent of the other Party, such consent not to be unreasonably withheld; or (iv) necessary to fulfill its obligations under this LGIA or as a transmission service provider or a Control Area operator including disclosing the Confidential Information to an RTO or ISO or to a regional or national reliability organization. The Party asserting confidentiality shall notify the other Party in writing of the information it claims is confidential. Prior to any disclosures of the other Party's Confidential Information under this subparagraph, or if any third party or Governmental Authority makes any request or demand for any of the information described in this subparagraph, the disclosing Party agrees to promptly notify the other Party in writing and agrees to assert confidentiality and cooperate with the other Party in seeking to protect the Confidential Information from public disclosure by confidentiality agreement, protective order or other reasonable measures.

Article 23. Environmental Releases

23.1 Each Party shall notify the other Party, first orally and then in writing, of the release of any Hazardous Substances, any asbestos or lead abatement activities, or any type of remediation activities related to the Large Generating Facility or the Interconnection Facilities, each of which may reasonably be expected to affect the other Party. The notifying Party shall: (i) provide the notice as soon as practicable, provided such Party makes a good faith effort to provide the notice no later than twenty-four hours after such Party becomes aware of the occurrence; and (ii) promptly furnish to the other Party copies of any publicly available reports filed with any Governmental Authorities addressing such events.

Article 24. Information Requirements

24.1 Information Acquisition. Transmission Provider and Interconnection Customer shall submit specific information regarding the electrical characteristics of their respective facilities to each other as described below and in accordance with Applicable Reliability Standards.

24.2 Information Submission by Transmission Provider. The initial information submission by Transmission Provider shall occur no later than one hundred eighty (180) Calendar Days prior to Trial Operation and shall include Transmission System information necessary to allow Interconnection Customer to select equipment and meet any system protection and stability requirements, unless otherwise agreed to by the Parties. On a monthly basis Transmission Provider shall provide Interconnection Customer a status report on the construction and installation of Transmission Provider's Interconnection Facilities and Network Upgrades, including, but not limited to, the following information: (1) progress to date; (2) a description of the activities since the last report" (3) a description of the action items for the next period; and (4) the delivery status of equipment ordered.

24.3 Updated Information Submission by Interconnection Customer. The updated information submission by Interconnection Customer, including manufacturer information, shall occur no later than one hundred eighty (180) Calendar Days prior to the Trial Operation. Interconnection Customer shall submit a completed copy of the Large Generating Facility data requirements contained in Appendix 1 to the LGIP. It shall also include any additional information provided to Transmission Provider for the Feasibility and Facilities Study. Information in this submission shall be the most current Large Generating Facility design or expected performance data. Information submitted for stability models shall be compatible with Transmission Provider standard models. If there is no compatible model, Interconnection Customer will work with a consultant mutually agreed to by the Parties to develop and supply a standard model and associated information.

If Interconnection Customer's data is materially different from what was originally provided to Transmission Provider pursuant to the Interconnection Study Agreement between Transmission Provider and Interconnection Customer, then Transmission Provider will conduct appropriate studies to determine the impact on Transmission Provider Transmission System based on the actual data submitted pursuant to this Article 24.3. The Interconnection Customer shall not begin Trial Operation until such studies are completed.

24.4 Information Supplementation. Prior to the Operation Date, the Parties shall supplement their information submissions described above in this Article 24 with any and all "as-built" Large Generating Facility information or "as-tested" performance information that differs from the initial submissions or, alternatively, written confirmation that no such differences exist. The Interconnection Customer shall conduct tests on the Large Generating Facility as required by Good Utility

Practice such as an open circuit "step voltage" test on the Large Generating Facility to verify proper operation of the Large Generating Facility's automatic voltage regulator.

Unless otherwise agreed, the test conditions shall include: (1) Large Generating Facility at synchronous speed; (2) automatic voltage regulator on and in voltage control mode; and (3) a five percent change in Large Generating Facility terminal voltage initiated by a change in the voltage regulators reference voltage. Interconnection Customer shall provide validated test recordings showing the responses of Large Generating Facility terminal and field voltages. In the event that direct recordings of these voltages is impractical, recordings of other voltages or currents that mirror the response of the Large Generating Facility's terminal or field voltage are acceptable if information necessary to translate these alternate quantities to actual Large Generating Facility terminal or field voltages is provided. Large Generating Facility testing shall be conducted and results provided to Transmission Provider for each individual generating unit in a station.

Subsequent to the Operation Date, Interconnection Customer shall provide Transmission Provider any information changes due to equipment replacement, repair, or adjustment. Transmission Provider shall provide Interconnection Customer any information changes due to equipment replacement, repair or adjustment in the directly connected substation or any adjacent Transmission Provider-owned substation that may affect Interconnection Customer's Interconnection Facilities equipment ratings, protection or operating requirements. The Parties shall provide such information no later than thirty (30) Calendar Days after the date of the equipment replacement, repair or adjustment.

Article 25. Information Access and Audit Rights

25.1 Information Access. Each Party (the "disclosing Party") shall make available to the other Party information that is in the possession of the disclosing Party and is necessary in order for the other Party to: (i) verify the costs incurred by the disclosing Party for which the other Party is responsible under this LGIA; and (ii) carry out its obligations and responsibilities under this LGIA. The Parties shall not use such information for purposes other than those set forth in this Article 25.1 and to enforce their rights under this LGIA.

25.2 Reporting of Non-Force Majeure Events. Each Party (the "notifying Party") shall notify the other Party when the notifying Party becomes aware of its inability to comply with the provisions of this LGIA for a reason other than a Force

Majeure event. The Parties agree to cooperate with each other and provide necessary information regarding such inability to comply, including the date, duration, reason for the inability to comply, and corrective actions taken or planned to be taken with respect to such inability to comply. Notwithstanding the foregoing, notification, cooperation or information provided under this article shall not entitle the Party receiving such notification to allege a cause for anticipatory breach of this LGIA.

25.3 Audit Rights. Subject to the requirements of confidentiality under Article 22 of this LGIA, each Party shall have the right, during normal business hours, and upon prior reasonable notice to the other Party, to audit at its own expense the other Party's accounts and records pertaining to either Party's performance or either Party's satisfaction of obligations under this LGIA. Such audit rights shall include audits of the other Party's costs, calculation of invoiced amounts, Transmission Provider's efforts to allocate responsibility for the provision of reactive support to the Transmission System, Transmission Provider's efforts to allocate responsibility for interruption or reduction of generation on the Transmission System, and each Party's actions in an Emergency Condition. Any audit authorized by this article shall be performed at the offices where such accounts and records are maintained and shall be limited to those portions of such accounts and records that relate to each Party's performance and satisfaction of obligations under this LGIA. Each Party shall keep such accounts and records for a period equivalent to the audit rights periods described in Article 25.4.

25.4 Audit Rights Periods.

25.4.1 Audit Rights Period for Construction-Related Accounts and Records. Accounts and records related to the design, engineering, procurement, and construction of Transmission Provider's Interconnection Facilities and Network Upgrades shall be subject to audit for a period of twenty-four months following Transmission Provider's issuance of a final invoice in accordance with Article 12.2.

25.4.2 Audit Rights Period for All Other Accounts and Records. Accounts and records related to either Party's performance or satisfaction of all obligations under this LGIA other than those described in Article 25.4.1 shall be subject to audit as follows: (i) for an audit relating to cost obligations, the applicable audit rights period shall be twenty-four months after the auditing Party's receipt of an invoice giving rise to such cost obligations; and (ii) for an audit

relating to all other obligations, the applicable audit rights period shall be twenty-four months after the event for which the audit is sought.

25.5 Audit Results. If an audit by a Party determines that an overpayment or an underpayment has occurred, a notice of such overpayment or underpayment shall be given to the other Party together with those records from the audit which support such determination.

Article 26. Subcontractors

26.1 General. Nothing in this LGIA shall prevent a Party from utilizing the services of any subcontractor as it deems appropriate to perform its obligations under this LGIA; provided, however, that each Party shall require its subcontractors to comply with all applicable terms and conditions of this LGIA in providing such services and each Party shall remain primarily liable to the other Party for the performance of such subcontractor.

26.2 Responsibility of Principal. The creation of any subcontract relationship shall not relieve the hiring Party of any of its obligations under this LGIA. The hiring Party shall be fully responsible to the other Party for the acts or omissions of any subcontractor the hiring Party hires as if no subcontract had been made; provided, however, that in no event shall Transmission Provider be liable for the actions or inactions of Interconnection Customer or its subcontractors with respect to obligations of Interconnection Customer under Article 5 of this LGIA. Any applicable obligation imposed by this LGIA upon the hiring Party shall be equally binding upon, and shall be construed as having application to, any subcontractor of such Party.

26.3 No Limitation by Insurance. The obligations under this Article 26 will not be limited in any way by any limitation of subcontractor's insurance.

Article 27. Disputes

27.1 Submission. In the event either Party has a dispute, or asserts a claim, that arises out of or in connection with this LGIA or its performance, such Party (the "disputing Party") shall provide the other Party with written notice of the dispute or claim ("Notice of Dispute"). Such dispute or claim shall be referred to a

designated senior representative of each Party for resolution on an informal basis as promptly as practicable after receipt of the Notice of Dispute by the other Party.

In the event the designated representatives are unable to resolve the claim or dispute through unassisted or assisted negotiations within thirty (30) Calendar Days of the other Party's receipt of the Notice of Dispute, such claim or dispute may, upon mutual agreement of the Parties, be submitted to arbitration and resolved in accordance with the arbitration procedures set forth below. In the event the Parties do not agree to submit such claim or dispute to arbitration, each Party may exercise whatever rights and remedies it may have in equity or at law consistent with the terms of this LGIA.

27.2 External Arbitration Procedures. Any arbitration initiated under this LGIA shall be conducted before a single neutral arbitrator appointed by the Parties. If the Parties fail to agree upon a single arbitrator within ten (10) Calendar Days of the submission of the dispute to arbitration, each Party shall choose one arbitrator who shall sit on a three-member arbitration panel. The two arbitrators so chosen shall within twenty (20) Calendar Days select a third arbitrator to chair the arbitration panel. In either case, the arbitrators shall be knowledgeable in electric utility matters, including electric transmission and bulk power issues, and shall not have any current or past substantial business or financial relationships with any party to the arbitration (except prior arbitration). The arbitrator(s) shall provide each of the Parties an opportunity to be heard and, except as otherwise provided herein, shall conduct the arbitration in accordance with the Commercial Arbitration Rules of the American Arbitration Association ("Arbitration Rules") and any applicable FERC regulations or RTO rules; provided, however, in the event of a conflict between the Arbitration Rules and the terms of this Article 27, the terms of this Article 27 shall prevail.

27.3 Arbitration Decisions. Unless otherwise agreed by the Parties, the arbitrator(s) shall render a decision within ninety (90) Calendar Days of appointment and shall notify the Parties in writing of such decision and the reasons therefor. The arbitrator(s) shall be authorized only to interpret and apply the provisions of this LGIA and shall have no power to modify or change any provision of this Agreement in any manner. The decision of the arbitrator(s) shall be final and binding upon the Parties, and judgment on the award may be entered in any court having jurisdiction. The decision of the arbitrator(s) may be appealed solely on the grounds that the conduct of the arbitrator(s), or the decision itself, violated the standards set forth in the Federal Arbitration Act or the Administrative Dispute Resolution Act. The final decision of the arbitrator must also be filed with FERC if it affects jurisdictional rates, terms and conditions of service, Interconnection Facilities, or Network Upgrades.

27.4 Costs. Each Party shall be responsible for its own costs incurred during the arbitration process and for the following costs, if applicable: (1) the cost of the arbitrator chosen by the Party to sit on the three member panel and one half of the cost of the third arbitrator chosen; or (2) one half the cost of the single arbitrator jointly chosen by the Parties.

Article 28. Representations, Warranties, and Covenants

28.1 General. Each Party makes the following representations, warranties and covenants:

28.1.1 Good Standing. Such Party is duly organized, validly existing and in good standing under the laws of the state in which it is organized, formed, or incorporated, as applicable; that it is qualified to do business in the state or states in which the Large Generating Facility, Interconnection Facilities and Network Upgrades owned by such Party, as applicable, are located; and that it has the corporate power and authority to own its properties, to carry on its business as now being conducted and to enter into this LGIA and carry out the transactions contemplated hereby and perform and carry out all covenants and obligations on its part to be performed under and pursuant to this LGIA.

28.1.2 Authority. Such Party has the right, power and authority to enter into this LGIA, to become a party hereto and to perform its obligations hereunder. This LGIA is a legal, valid and binding obligation of such Party, enforceable against such Party in accordance with its terms, except as the enforceability thereof may be limited by applicable bankruptcy, insolvency, reorganization or other similar laws affecting creditors' rights generally and by general equitable principles (regardless of whether enforceability is sought in a proceeding in equity or at law).

28.1.3 No Conflict. The execution, delivery and performance of this LGIA does not violate or conflict with the organizational or formation documents, or bylaws or operating agreement, of such Party, or any judgment, license, permit, order, material agreement or instrument applicable to or binding upon such Party or any of its assets.

28.1.4 Consent and Approval. Such Party has sought or obtained, or, in accordance with this LGIA will seek or obtain, each consent, approval, authorization, order, or acceptance by any Governmental Authority in connection with the execution, delivery and performance of this LGIA, and it will provide to any Governmental Authority notice of any actions under this LGIA that are required by Applicable Laws and Regulations.

Article 29. Joint Operating Committee

29.1 Joint Operating Committee. Except in the case of ISOs and RTOs, Transmission Provider shall constitute a Joint Operating Committee to coordinate operating and technical considerations of Interconnection Service. At least six (6) months prior to the expected Initial Synchronization Date, Interconnection Customer and Transmission Provider shall each appoint one representative and one alternate to the Joint Operating Committee. Each Interconnection Customer shall notify Transmission Provider of its appointment in writing. Such appointments may be changed at any time by similar notice. The Joint Operating Committee shall meet as necessary, but not less than once each calendar year, to carry out the duties set forth herein. The Joint Operating Committee shall hold a meeting at the request of either Party, at a time and place agreed upon by the representatives. The Joint Operating Committee shall perform all of its duties consistent with the provisions of this LGIA. Each Party shall cooperate in providing to the Joint Operating Committee all information required in the performance of the Joint Operating Committee's duties. All decisions and agreements, if any, made by the Joint Operating Committee, shall be evidenced in writing. The duties of the Joint Operating Committee shall include the following:

- 29.1.1** Establish data requirements and operating record requirements.
- 29.1.2** Review the requirements, standards, and procedures for data acquisition equipment, protective equipment, and any other equipment or software.
- 29.1.3** Annually review the one (1) year forecast of maintenance and planned outage schedules of Transmission Provider's and Interconnection Customer's facilities at the Point of Interconnection.
- 29.1.4** Coordinate the scheduling of maintenance and planned outages on

the Interconnection Facilities, the Large Generating Facility and other facilities that impact the normal operation of the interconnection of the Large Generating Facility to the Transmission System.

- 29.1.5** Ensure that information is being provided by each Party regarding equipment availability.
- 29.1.6** Perform such other duties as may be conferred upon it by mutual agreement of the Parties.

Article 30. Miscellaneous

- 30.1 Binding Effect.** This LGIA and the rights and obligations hereof, shall be binding upon and shall inure to the benefit of the successors and assigns of the Parties hereto.
- 30.2 Conflicts.** In the event of a conflict between the body of this LGIA and any attachment, appendices or exhibits hereto, the terms and provisions of the body of this LGIA shall prevail and be deemed the final intent of the Parties.
- 30.3 Rules of Interpretation.** This LGIA, unless a clear contrary intention appears, shall be construed and interpreted as follows: (1) the singular number includes the plural number and vice versa; (2) reference to any person includes such person's successors and assigns but, in the case of a Party, only if such successors and assigns are permitted by this LGIA, and reference to a person in a particular capacity excludes such person in any other capacity or individually; (3) reference to any agreement (including this LGIA), document, instrument or tariff means such agreement, document, instrument, or tariff as amended or modified and in effect from time to time in accordance with the terms thereof and, if applicable, the terms hereof; (4) reference to any Applicable Laws and Regulations means such Applicable Laws and Regulations as amended, modified, codified, or reenacted, in whole or in part, and in effect from time to time, including, if applicable, rules and regulations promulgated thereunder; (5) unless expressly stated otherwise, reference to any Article, Section or Appendix means such Article of this LGIA or such Appendix to this LGIA, or such Section to the LGIP or such Appendix to the LGIP, as the case may be; (6) "hereunder", "hereof", "herein", "hereto" and words of similar import shall be deemed references to this LGIA as a whole and not to any particular Article or other provision hereof or thereof; (7) "including" (and with correlative meaning "include") means including without limiting the

generality of any description preceding such term; and (8) relative to the determination of any period of time, "from" means "from and including", "to" means "to but excluding" and "through" means "through and including".

30.4 Entire Agreement. This LGIA, including all Appendices and Schedules attached hereto, constitutes the entire agreement between the Parties with reference to the subject matter hereof, and supersedes all prior and contemporaneous understandings or agreements, oral or written, between the Parties with respect to the subject matter of this LGIA. There are no other agreements, representations, warranties, or covenants which constitute any part of the consideration for, or any condition to, either Party's compliance with its obligations under this LGIA.

30.5 No Third Party Beneficiaries. This LGIA is not intended to and does not create rights, remedies, or benefits of any character whatsoever in favor of any persons, corporations, associations, or entities other than the Parties, and the obligations herein assumed are solely for the use and benefit of the Parties, their successors in interest and, where permitted, their assigns.

30.6 Waiver. The failure of a Party to this LGIA to insist, on any occasion, upon strict performance of any provision of this LGIA will not be considered a waiver of any obligation, right, or duty of, or imposed upon, such Party.

Any waiver at any time by either Party of its rights with respect to this LGIA shall not be deemed a continuing waiver or a waiver with respect to any other failure to comply with any other obligation, right, duty of this LGIA. Termination or Default of this LGIA for any reason by Interconnection Customer shall not constitute a waiver of Interconnection Customer's legal rights to obtain an interconnection from Transmission Provider. Any waiver of this LGIA shall, if requested, be provided in writing.

30.7 Headings. The descriptive headings of the various Articles of this LGIA have been inserted for convenience of reference only and are of no significance in the interpretation or construction of this LGIA.

30.8 Multiple Counterparts. This LGIA may be executed in two or more counterparts, each of which is deemed an original but all constitute one and the same instrument.

30.9 Amendment. The Parties may by mutual agreement amend this LGIA by a written instrument duly executed by the Parties.

30.10 Modification by the Parties. The Parties may by mutual agreement amend the Appendices to this LGIA by a written instrument duly executed by the Parties. Such amendment shall become effective and a part of this LGIA upon satisfaction of all Applicable Laws and Regulations.

30.11 Reservation of Rights. Transmission Provider shall have the right to make a unilateral filing with FERC to modify this LGIA with respect to any rates, terms and conditions, charges, classifications of service, rule or regulation under section 205 or any other applicable provision of the Federal Power Act and FERC's rules and regulations thereunder, and Interconnection Customer shall have the right to make a unilateral filing with FERC to modify this LGIA pursuant to section 206 or any other applicable provision of the Federal Power Act and FERC's rules and regulations thereunder; provided that each Party shall have the right to protest any such filing by the other Party and to participate fully in any proceeding before FERC in which such modifications may be considered. Nothing in this LGIA shall limit the rights of the Parties or of FERC under sections 205 or 206 of the Federal Power Act and FERC's rules and regulations thereunder, except to the extent that the Parties otherwise mutually agree as provided herein.

30.12 No Partnership. This LGIA shall not be interpreted or construed to create an association, joint venture, agency relationship, or partnership between the Parties or to impose any partnership obligation or partnership liability upon either Party. Neither Party shall have any right, power or authority to enter into any agreement or undertaking for, or act on behalf of, or to act as or be an agent or representative of, or to otherwise bind, the other Party.

IN WITNESS WHEREOF, the Parties have executed this Agreement in duplicate originals, each of which shall constitute and be an original effective Agreement between the Parties.

Southwest Power Pool, Inc.

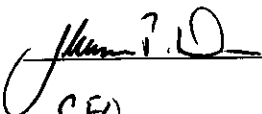
By: 
Title: CEO
Date: 11-29-04

Southwestern Public Service Company (d/b/a Xcel Energy)

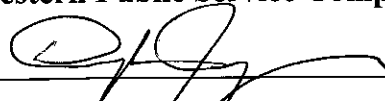
By: 
Title: Authorized Agent for SPS, VP Transmission
Date: 11/22/04

East Guymon Wind L.L.C

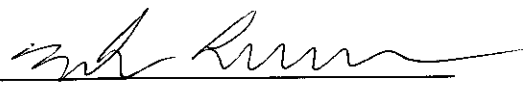
By: 
Title: Vice President of Inverenergy LLC, its member
Date: 11/8/04

Appendices to Agreement

Appendix A Interconnection Facilities, Network Upgrades and Distribution Upgrades

Appendix B Milestones

Appendix C Interconnection Details

Appendix D Security Arrangements Details

Appendix E Commercial Operation Date

Appendix F Addresses for Delivery of Notices and Billings

Appendix G Requirements of Generators Relying on Newer Technologies

Appendix A To Agreement

Interconnection Facilities, Network Upgrades and Distribution Upgrades

NOTE: The facilities described in this Appendix are based on the studies conducted in response to the Interconnection Request. In the event that other interconnection customers suspend, terminate or request unexecuted filing of their LGIAs, then additional studies may be required that could result in changes to the Interconnection Facilities and the Network Upgrades and in changes to Interconnection Customer's cost obligations for those facilities.

1. Interconnection Facilities:

(a) Interconnection Customer's Interconnection Facilities to be designed, procured, constructed and installed by Interconnection Customer:

The Interconnection Customer's new wind energy project's 115/34.5 kV interconnection substation will be located approximately 2 miles east of Guymon, Oklahoma. This wind energy project will consist of 100 General Electric (GE) wind turbines with a nominal output of 1.5 MW each, for a limited output of 150 MW

The Interconnection Customer's Interconnection Facilities will be comprised of:

- five (5) or more 34.5 kV underground cable collection circuits;
- one (1) 34.5 kV to 115 kV transformation substation with associated 34.5 kV and 115 kV switchgear. The 34.5 kV to 115 kV transformer will have a grounded wye connection on the 115 kV side;
- one (1) new 115kV line that will tie the 115/34.5kV wind farm substation to the Point-of-Interconnection and Point-of-Change-of Ownership with the Transmission Owner's Texas County Interchange.
- Right-of-way tasks associated with the procurement of real estate, or right-of-way surveying, title search etc. for the 115 kV transmission line that will tie the 115/34.5kV wind farm substation to the Transmission Owner's Texas County Interchange.
- Permitting if required for 115 kV line above which may include environmental, biological, archaeological and any other studies, and
- all necessary relay, protection, control and communication systems in the required Interconnection Customers wind farm and interconnection substation required to protect Interconnection Customer's Generating Facilities and Interconnection Facilities and coordinate with Transmission Owner's relay, protection, control and communication systems.

(b) Transmission Owner's Interconnection Facilities to be designed, procured, constructed and installed by Transmission Owner:

- Modify the 115kV bus at Texas County. Interchange will be expanded to serve the Customer's new 115 kV line
- 115kV transmission line termination from the Interconnection Customer's dead end structure at the Point of Interconnection into the Texas County Interchange
- Additional control house to accommodate the required metering, protection and control devices, and terminal cabinets and misc. equipment.
- Revenue metering will be installed on the Transmission line to the wind farm
- Communications
 - RTU communication will require 4 wire data circuit between Texas County Interchange and Xcel Amarillo Service Center
 - Xcel Substation will also require Dial-up (POTS) telephone service for substation communication and remote access into the billing meter. This will only require one POTS line.

Total Cost \$ 613,949

2. Network Upgrades:

(a) Stand Alone Network Upgrades to be designed, procured, constructed and installed by Transmission Owner:

There are no Transmission Owner Stand Alone Network Upgrades.

(b) Other Network Upgrades to be designed, procured, constructed and installed by Transmission Owner:

There are no other Network Upgrades.

(c) Joint Network Upgrades

There no Joint Network Upgrades

(d) Previous Network Upgrades

There are no Previous Network Upgrades

(e) The cost for the Transmission Owner's Interconnection Facilities to be constructed by Interconnection Customer is estimated at \$ 0.

(f) The total cost for the Transmission Owner's Interconnection Facilities and Network Upgrades is estimated at \$ 613,949.

(g) The portion of the Network Upgrades that is subject to the transmission service credits described in Section 11.4 of this Agreement is estimated at \$ 0.

3. Distribution Upgrades:

There are no Transmission Owner Distribution Upgrades

4. Interconnection Service: Interconnection Customer has selected the following:

- MW Energy Resource Interconnection Service
- MW Network Resource Interconnection Service within Transmission Owner's Control Area
- MW Network Resource Interconnection Service to outside Transmission Owner's Control Area

5. Construction Option Selected by Interconnection Customer:

Interconnection Customer has selected the Alternate Option for construction of the Transmission Owner's Interconnection Facilities and the Network Upgrades.

6. Eligible Network Customers:

Not Used

7. Permits, Licenses and Authorizations:

The Interconnection Customer is responsible to secure all Permits, Licenses and Authorizations necessary for the construction and operation of its Generating Facilities and Interconnection Facilities:

WIND FARM INTERCONNECTION

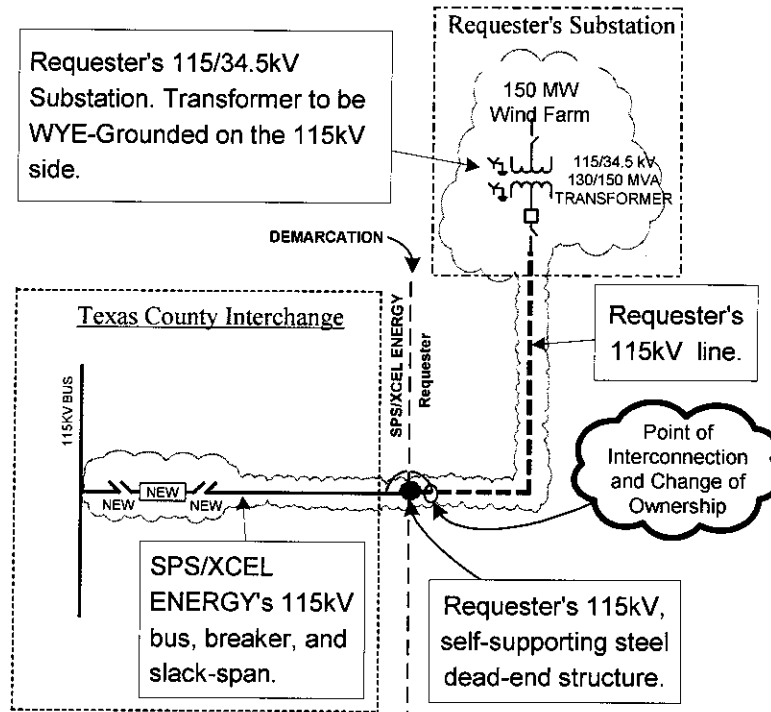

Figure A-1 Wind Farm Interconnection

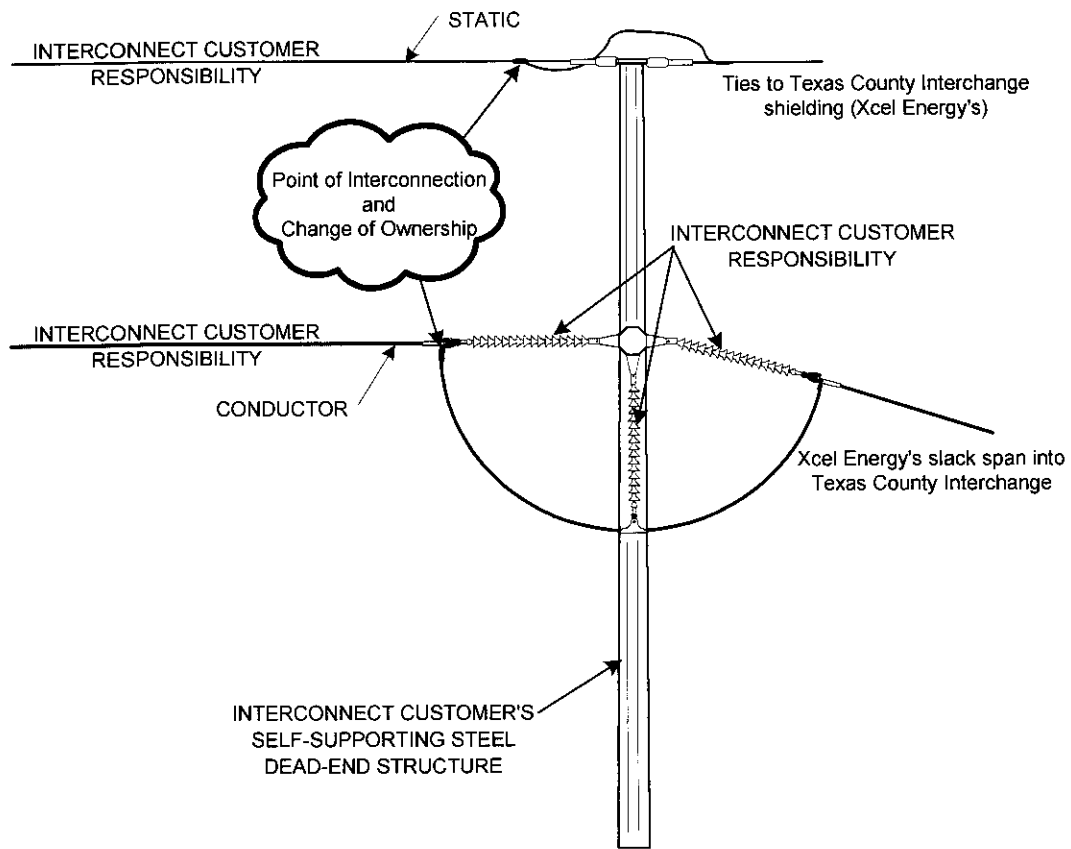

Figure A-2 Point of Interconnection and Change of Ownership

**Appendix B
To Agreement**

Milestones

<u>Action</u>	<u>Responsible Party</u>	<u>Completion Date</u>
Complete Facilities Study	Transmission Provider	02/19/04
Obtain Governmental Authorization	Transmission Owner	N/A
Provide authorization to proceed with design and procurement	Interconnection Customer	01/01/05
Provide financial security for design and procurement (\$50,000)	Interconnection Customer	01/01/05
Provide authorization to proceed with construction	Interconnection Customer	03/01/2005
Provide financial security for construction (\$563,949)	Interconnection Customer	03/01/2005
Complete Transmission Owner's Interconnection Facilities	Transmission Owner	10/21/2005
In-Service Date	Interconnection Customer	10/21/05
Energize Interconnection Customer's Interconnection Facilities	Interconnection Customer	11/01/2005
Initial Synchronization Date; Begin Trial Operation	Interconnection Customer	11/01/2005
Projected commercial operation date	Interconnection Customer	12/01/2005

Appendix C To Agreement

Interconnection Details

General: Transmission Provider, Transmission Owner, and Interconnection Customer agree that the Generating Facility cannot be, and is not equipped with Power System Stabilizers.

Transmission Provider, Transmission Owner, and Interconnection Customer agree that the operation of the Generating Facility with the proposed General Electric (GE) wind turbine generators with reactive power control capable of controlling the interconnection power factor shall satisfy the power factor requirements stated as follows. Over the full range of the wind farm's generating capacity, the power factor at the point of interconnection shall be within the range of 0.98 (generation absorbing VARS) to a 0.95 (generation supplying VARS) to the Transmission Owner's transmission system.

In order to accommodate possible minor changes in operating conditions, SPP, or the Transmission Operator may permit, at its sole discretion, adjustments to the specified limits.

Facility: The Interconnection Customer's Wind Energy Project is a new wind energy generation facility located approximately 3 miles east of Guymon, Oklahoma. The new wind energy generation facility will interconnect the 150 MW wind facility to the transmission on a new 115kV transmission line tied to Texas County Interchange. The new wind energy project's 115/34.5 kV interconnection substation will be located approximately 2 miles east of Guymon, Oklahoma. The 115/34.5 kV transformer will have a grounded wye connection on the 115 kV. This wind energy project will consist of 100 General Electric (GE) wind turbines with a nominal output of 1.5 MW each, for a nominal output of 150 MW.

Point of Interconnection: The Interconnection Customer's 115kV line will terminate to their self-supporting steel dead-end structure just outside the Texas County Interchange fence. Xcel Energy will terminate the Interconnection Customer's 115kV line with a single slack span of 795MCM ACSR conductor with 3/8" EHS static wire from the Requester's dead-end structure to the Texas County Interchange steel. The line terminals will be designed to accommodate 2,000 pounds per phase conductor at maximum tension heavy-load and two shield wires designed to accommodate 2,000 pounds each at maximum tension heavy-load. The point of interconnection will be the connection between the Interconnection Customer's phase conductors terminated on their dead-end structure located just outside the Texas County Interchange fence, and the slack-span jumper. See Figure A-1, Wind Farm Interconnection and Figure A-2, Point of Interconnection in Appendix A.

Revenue Metering: At Texas County Interchange, Xcel Energy will install on the line to the Interconnection Customer's wind farm, billing meters with a 115 kV CTs for full 3 phase 4-wire

metering. There will be two meters: one will be primary and the other will be back-up, each will have full 4 quadrant metering. Metering pulses will be sent via SCADA to the Transmission Owner's Control Center in Amarillo, Texas.

Relay and Protection Scheme: On the 115kV line from Texas County Interchange to the Interconnection Customer's owned line, relaying will be step distance where a SEL 321-1 and SEL 311-C relays will be used. A SEL 279H-2 relay will be installed for line/bus conditions and sync check along with supervisory closing of the breaker. There will not be any automatic reclosing. A SEL 501-0 will be used for breaker failure

OPERATING GUIDELINES

SWITCHING AND TAGGING PROCEDURES

1. **Definitions**

- 1.1 CLEARANCE - The process of removing and holding a transmission line, section of bus or piece of equipment from service so that work may be safely performed.
- 1.2 CLEARANCE TAG - The formal registered tag in the Transmission Owner's Switching Procedures document. It is applied at the switches and disconnects through which electrical energy may be supplied to the section of line or equipment at which safety CLEARANCE is desired. It may be used with proper authority and registration at all voltage levels. A CLEARANCE TAG is NEVER used to hold circuits or equipment IN service.

2. **Planned Clearance Request in the Facility Originated by Interconnection Customer**

- 2.1 If the switching on the Facility requires switching of equipment owned by the Interconnection Customer and controlled by SPP or Transmission Owner, then the Interconnection Customer will send a Clearance Request to the Transmission Owner's or SPP's Transmission System operator to facilitate the switching.

3. **Planned Clearance Request originated by Interconnection Customer**

- 3.1 Any planned switching originated by the Interconnection Customer which requires switching of equipment controlled by SPP or Transmission Owner, will be coordinated with a Clearance Request through the Transmission Owner's transmission system operator with a minimum of 24 hours notice except in emergency situations (notices of between 24 hours and ten days may be required depending on the impact of the outage on the transmission grid). The Transmission Owner's transmission system operator will accommodate the request as soon as practicable. Personnel availability and system conditions may prevent a Clearance Request from being completed. The Interconnection Customer personnel will perform all switching and apply all CLEARANCE TAGS to equipment owned by the Interconnection Customer in the Interconnection Customer's substation. Transmission Owner personnel may observe the switching if desired.

4. **Planned Clearance Request in the Interconnection Customer's Facilities originated by the Transmission Owner**

- 4.1 All planned Clearance Requests on the Facility, which requires switching of equipment controlled by the Interconnection Customer and originated by SPP or Transmission Owner, will be coordinated with the Interconnection Customer's personnel by a Clearance Request submitted by Transmission Owner personnel with

a minimum of 48 hours notice except in emergency situations. The Interconnection Customer will accommodate the request as soon as practicable. All switching and application of CLEARANCE TAGS on equipment owned by Interconnection Customer, in the Interconnection Customer's Facilities, will be performed by the Interconnection Customer's personnel. Transmission Owner personnel will be allowed to observe all switching if desired. Once the Interconnection Customer's operator is assured that all devices are properly opened and tagged, the Interconnection Customer's personnel will provide CLEARANCE to the Transmission Owner's Transmission System Operator.

5. Planned Clearance Request originated by Transmission Owner

- 5.1 Interconnection Customer will be notified for informational purposes only of any planned Clearance Request on the Transmission System that do not require total isolation of the Interconnection Customer Facilities.
- 5.2 Any planned Clearance Requests that would result in the isolation of the Interconnection Customer Facilities from the Transmission System or in a reduction in interconnection capacity will be coordinated with the Interconnection Customer.

6. Unplanned Requests To Isolate Interconnection Customer Facilities By Remote Breaker Operations

- 6.1 Interconnection Customer may request the Transmission Owner's transmission system operator to isolate the Interconnection Customer Facilities from the Transmission Owner's system by remote opening breakers. The Transmission Owner's transmission system operator will accommodate the request as soon as practicable. System conditions may prevent such a request from being completed. Clearance will not be given and the Interconnection Customer's personnel must isolate the Interconnection Customer Facilities before starting work. If Clearance is required then request must be made under the procedures of Section 3.1 above.

7. Unplanned Outages

- 7.1 If an unplanned interruption occurs in either the Facility or the Transmission System, both the Transmission Owner's transmission system operator and the Interconnection Customer's personnel will provide the other with all pertinent information. This information will include, but may not be limited to:
 - 1. the devices involved,
 - 2. present status of devices in question,
 - 3. time stamps,
 - 4. cause of interruption (if available),
 - 5. relay targets (if available),
 - 6. any information helpful in determining cause and/or useful in the restoration

process

8. Re-energization

Procedures for Re-energizing Interconnection Customer's Facilities after Isolation from the Transmission Owner's System

- 8.1 Interconnection Customer's personnel must request the Transmission Owner's transmission system operator to re-energize the Interconnection Customer Facilities after they have become isolated.

9. Emergency Switching

Emergency Switching to Isolate the Interconnection Customer's Facilities from the Transmission Owner's System

- 9.1 During emergency situations, Transmission Owner's personnel may request Interconnection Customer's personnel to disconnect the generators at the Facility or Transmission Owner may disconnect generator remotely at the point of interconnect.

10 Communications Requirements

10.1 Interconnection Customer's operating personnel will notify the Transmission Owner's System Operator of the following:

- Prior to synchronization of when the Facility commences operation;
- Prior to the Facility ceasing operations;
- As soon as possible after an unplanned separation of all generators;
- For Clearance Requests for Interconnection Customer's equipment requiring switching on the Transmission Owner's system; and
- When abnormal system conditions are affecting the operation of the Interconnection Customer Facilities.

10.3 The Transmission Owner's System Operator will notify Interconnection Customer's operating personnel:

- When conditions may prevent generator synchronization;
- When conditions may require generator separation;
- On a requirement for generator separation;
- On the requirement for redispatch during a System Emergency; and
- For Clearance Request for Transmission Owner's operated equipment requiring switching on the Interconnection Customer's Interconnection Facilities.

10.4 Interconnection Customer's operating personnel will also be required to provide hourly meter readings (MWH and MVar) to the Transmission Owner's System Operator in the event of a telemetry failure from the Interconnection Facilities. This

will occur at least once per day before 9:00 a.m. Central time.

10.5 It is also anticipated that the Transmission Owner's System Operator, SPP and Interconnection Customer's operating personnel will communicate, beyond the notices as listed above, as necessary and appropriate, in accordance with Good Utility Practice, to provide reliable and efficient operation of both the Transmission Owner's system and the Interconnection Customer's Facilities.

Appendix D To Agreement

Security Arrangements Details

Infrastructure security of Transmission System equipment and operations and control hardware and software is essential to ensure day-to-day Transmission System reliability and operational security. FERC will expect all Transmission Providers, market participants, and Interconnection Customers interconnected to the Transmission System to comply with the recommendations offered by the President's Critical Infrastructure Protection Board and, eventually, best practice recommendations from the electric reliability authority. All public utilities will be expected to meet basic standards for system infrastructure and operational security, including physical, operational, and cyber-security practices.

The Parties will cooperate reasonably to comply with the recommendations described in paragraph 1 and to implement the applicable standards. The following communications schematic diagram for the project including the Interconnection Customer, Transmission Provider (Southwest Power Pool) and Transmission Owner (Southwestern Public Service) is provided to assist the Parties in meeting these standards.

Communications Schematic Diagram

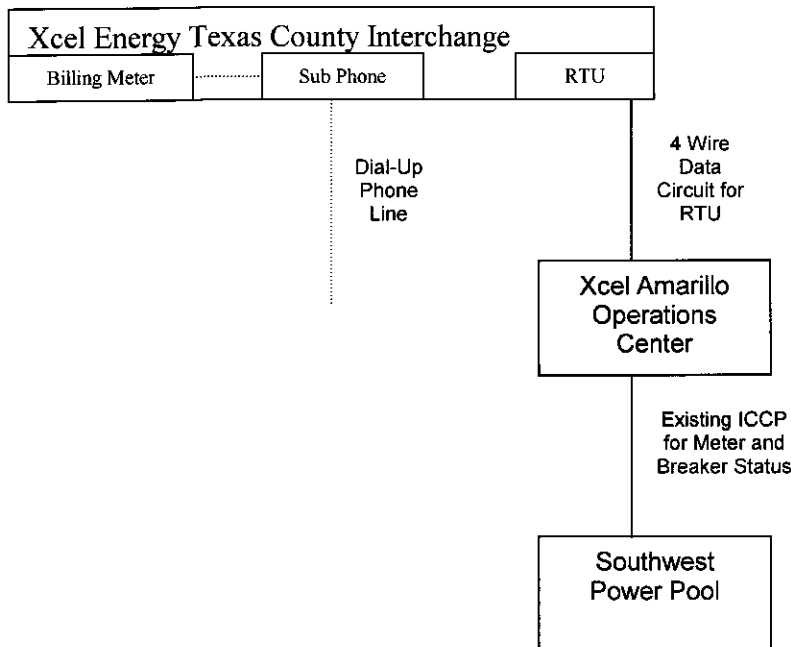

**Appendix E
To Agreement**

Commercial Operation Date

This Appendix E is a part of the Agreement between Transmission Provider, Transmission Owner and Interconnection Customer.

[Date]

Carl Monroe, Vice President
Southwest Power Pool, Inc.
415 N. McKinley, 800 Plaza West
Little Rock, AR 72205
Phone: 501-614-3200
Facsimile: 501-664-9553

Transmission Account Representative
Xcel Energy
6086 W. 48th St.
Amarillo, Texas 79109

Re: East Guymon Wind Generating Facility

Dear _____:

On **[Date]** East Guymon Wind LLC has completed Trial Operation of Unit No. _____. This letter confirms that East Guymon Wind LLC] commenced commercial operation of Unit No. _____ at the Generating Facility, effective as of **[Date plus one day]**.

Thank you.

[Signature]

Project Manager
East Guymon Wind LLC
233 S. Wacker Dr.
Suite 9450
Chicago, IL 60606

**Appendix F
To Agreement**

Addresses for Delivery of Notices and Billings

Notices:

Transmission Provider:

Carl Monroe, Vice President
Southwest Power Pool, Inc.
415 N. McKinley, 800 Plaza West
Little Rock, AR 72205-3020

Transmission Owner:

Transmission Account Representative
Xcel Energy
6086 W. 48th St.
Amarillo, Texas 79109

Interconnection Customer:

East Guymon Project Manager
East Guymon Wind LLC
c/o Invenenergy LLC
233 S. Wacker Dr.
Suite 9450
Chicago, IL 60606

Billings and Payments: [Specify addresses for construction invoices, O&M invoices and settlement of ancillary services]

Transmission Provider:

Carl Monroe, Vice President

Southwest Power Pool, Inc
415 N. McKinley, 800 Plaza West
Little Rock, AR 72205-3020

Transmission Owner:

Transmission Account Representative
Xcel Energy
6086 W. 48th St.
Amarillo, Texas 79109

Interconnection Customer:

Project Manager
East Guymon Wind LLC
233 S. Wacker Dr.
Suite 9450
Chicago, IL 60606

Alternative Forms of Delivery of Notices (telephone, facsimile or email):

Transmission Provider:

Carl Monroe, Vice President
Southwest Power Pool, Inc.
415 N. McKinley, 800 Plaza West
Little Rock, AR 72205
Phone: 501-614-3200
Facsimile: 501-664-9553

Transmission Owner:

Transmission Account Representative
Xcel Energy
6086 W. 48th St.

Amarillo, Texas 79109
Phone: 806-457-6302
Facsimile: 806-457-6460

Interconnection Customer:

Project Manager
East Guymon Wind LLC
c/o Invenergy LLC
233 South Wacker Drive, Suite 9450
Chicago, IL 60606
Phone: 312.707.9044
Facsimile: 312.707.9045
bschueler@invenergyllc.com

Operational Communications:

Transmission Provider:

Southwest Power Pool, Inc.
415 N. McKinley, 800 Plaza West
Little Rock, AR 72205
Phone: 501-614-3200
Facsimile: 501-664-9553

Transmission Owner:

SPS Transmission Operator
SPS Amarillo Operations Center
6086 W. 48th Street
Amarillo, Texas 79109
Phone: 806-457-6343
Facsimile: 806-457-6349

Interconnection Customer:

Project Manager
East Guymon Wind LLC
c/o Invenergy LLC
233 South Wacker Drive, Suite 9450
Chicago, IL 60606
Phone: 312.707.9044

Facsimile: 312.707.9045
bschueler@invenergyllc.com

**Appendix G
To Agreement**

Requirements of Generators Relying on Newer Technologies

EXHIBIT V

Appendix A To Agreement

Interconnection Facilities, Network Upgrades and Distribution Upgrades

NOTE: The facilities described in this Appendix are based on the studies conducted in response to the Interconnection Request. -In the event that other interconnection customers suspend, terminate or request unexecuted filing of their LGIAs, then additional studies may be required that could result in changes to the Interconnection Facilities and the Network Upgrades and in changes to Interconnection Customer's cost obligations for those facilities.

1. Interconnection Facilities:

(a) Interconnection Customer's Interconnection Facilities to be designed, procured, constructed and installed by Interconnection Customer at the Interconnection Customer's funding and sole expense. These facilities will be owned and controlled by Interconnection Customer:

The Interconnection Customer's new wind energy project's 115/34.5 kV interconnection substation will be located approximately 2 miles east of Guymon, Oklahoma. This wind energy project will consist of 100 General Electric (GE) wind turbines with a nominal output of 1.5 MW each, for a limited output of 150 MW.

The Interconnection Customer's Interconnection Facilities will be comprised of:

- five (5) or more 34.5 kV underground cable collection circuits;
- one (1) 34.5 kV to 115 kV transformation substation with associated 34.5 kV and 115 kV switchgear. The 34.5 kV to 115 kV transformer will have a grounded wye connection on the 115 kV side;
- one (1) new 115kV line that will tie the 115/34.5kV wind farm substation to the Point-of-Interconnection and Point-of-Change-of Ownership with the Transmission Owner's Texas County Interchange; and-
- ~~Right of way tasks associated with the procurement of real estate, or right of way surveying, title search etc. for the 115 kV transmission line that will tie the 115/34.5kV wind farm substation to the Transmission Owner's Texas County Interchange.~~
- ~~Permitting if required for 115 kV line above which may include environmental, biological, archaeological and any other studies, and~~
- all necessary relay, protection, control and communication systems in the ~~required~~ Interconnection Customers wind farm and interconnection substation required to protect Interconnection Customer's Generating Facilities and Interconnection Facilities and coordinate with Transmission Owner's relay, protection, control

and communication systems.

(b) Transmission Owner's Interconnection Facilities to be designed, procured, constructed and installed by Transmission Owner at the Interconnection Customer's funding and sole expense. These facilities will be owned and controlled by the Transmission Owner:

- Modify the 115kV bus at Texas County. Interchange will be expanded to serve the Customer's new 115 kV line;
- 115kV transmission line termination from the Interconnection Customer's dead end structure at the Point of Interconnection into the Texas County Interchange;
- Additions to the ~~Additional~~ control house to accommodate the required metering, protection and control devices, and terminal cabinets and misc. equipment;
- Revenue metering equipment to ~~will~~ be installed on the t ~~Transmission~~ line to the wind farm; and
- Communications
 - RTU communication will require 4-4 ~~wire~~ data circuit between Texas County Interchange and Xcel Energy's Amarillo Service Center
 - ~~Xcel Substation will also require Dial-up (POTS) telephone service for substation communication and remote access into the billing meter. This will only require one POTS line.~~

Total Cost \$ 498,580~~613,949~~

2. Network Upgrades:

(a) Stand Alone Network Upgrades to be designed, procured, constructed and installed by Transmission Owner:

There are no ~~Transmission Owner~~ Stand Alone Network Upgrades.

(b) Other Network Upgrades to be designed, procured, constructed and installed by Transmission Owner:

There are no other Network Upgrades.

(c) Joint Network Upgrades

There no Joint Network Upgrades.

(d) Previous Network Upgrades

There are no Previous Network Upgrades.

(e) The cost for the Transmission Owner's Interconnection Facilities to be constructed by Interconnection Customer is estimated at \$ 0.

(f) The total cost for the Transmission Owner's Interconnection Facilities to be constructed by the Transmission Owner at the Interconnection Customer's expense is estimated at \$498,580. The Interconnection Customer is responsible for the payment of the engineering, procurement and construction of the Transmission Owner's Interconnection Facilities estimated at \$498,580 pursuant to the schedule as indicated in Appendix B, Milestones.

All cost estimates were developed using a +/- 20 percent estimate according to the LGIP. All costs are estimated in 2008 dollars with no escalation applied for the purpose of this estimate. All estimates will be trued up for actual costs and expenses for purposes of final billing under Article 12.2.
~~and Network Upgrades is estimated at \$ 613,949.~~

(g) The portion of the Network Upgrades that is subject to the transmission service credits described in Section 11.4 of this Agreement is estimated at \$ 0.

3. Distribution Upgrades:

There are no Transmission Owner Distribution Upgrades

4. Interconnection Service: Interconnection Customer has selected the following:

150~~X~~ MW Energy Resource Interconnection Service
 MW Network Resource Interconnection Service within Transmission Owner's Control Area
 MW Network Resource Interconnection Service to outside Transmission Owner's Control Area

5. Construction Option Selected by Interconnection Customer:

Interconnection Customer has selected the Standard~~Alternate~~ Option for construction of the Transmission Owner's Interconnection Facilities and the Network Upgrades.

6. Eligible Network Customers:

Not Used

7. Permits, Licenses and Authorizations:

The Interconnection Customer is responsible to secure all Permits, Licenses and Authorizations necessary for the construction and operation of its Generating Facilities and Interconnection Facilities.

WIND FARM INTERCONNECTION

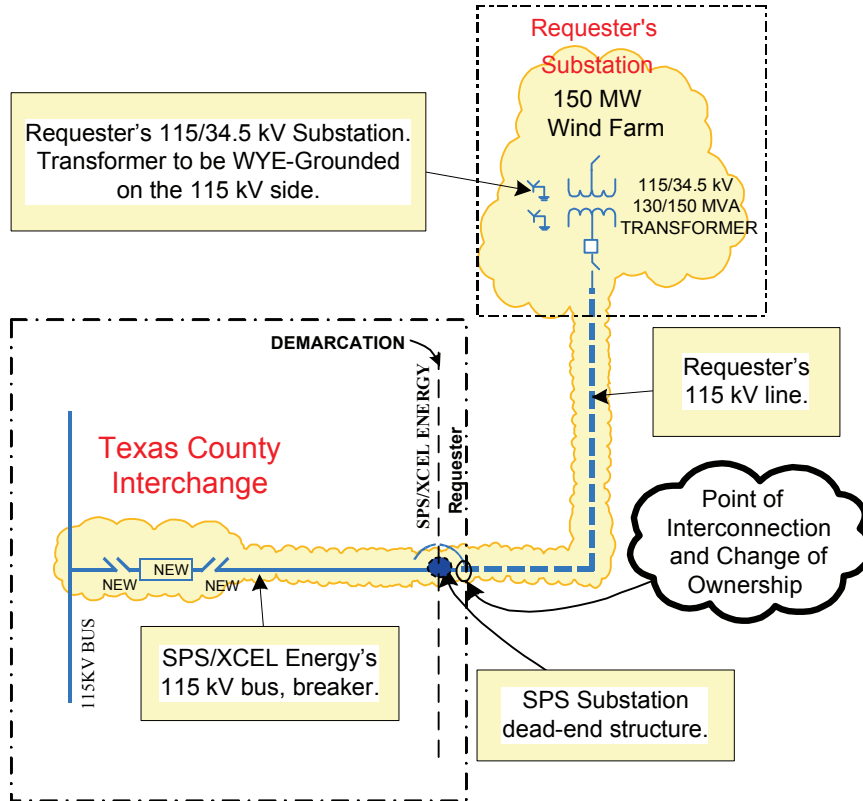
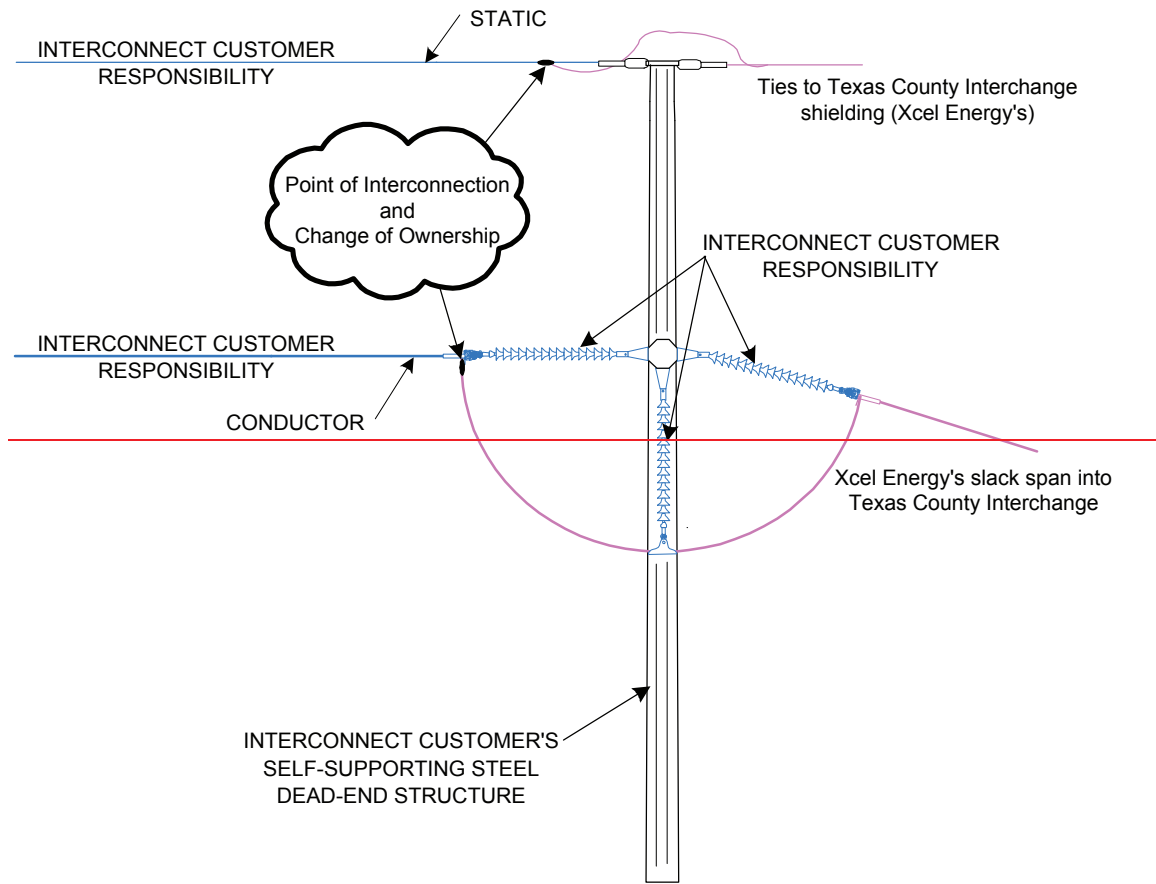
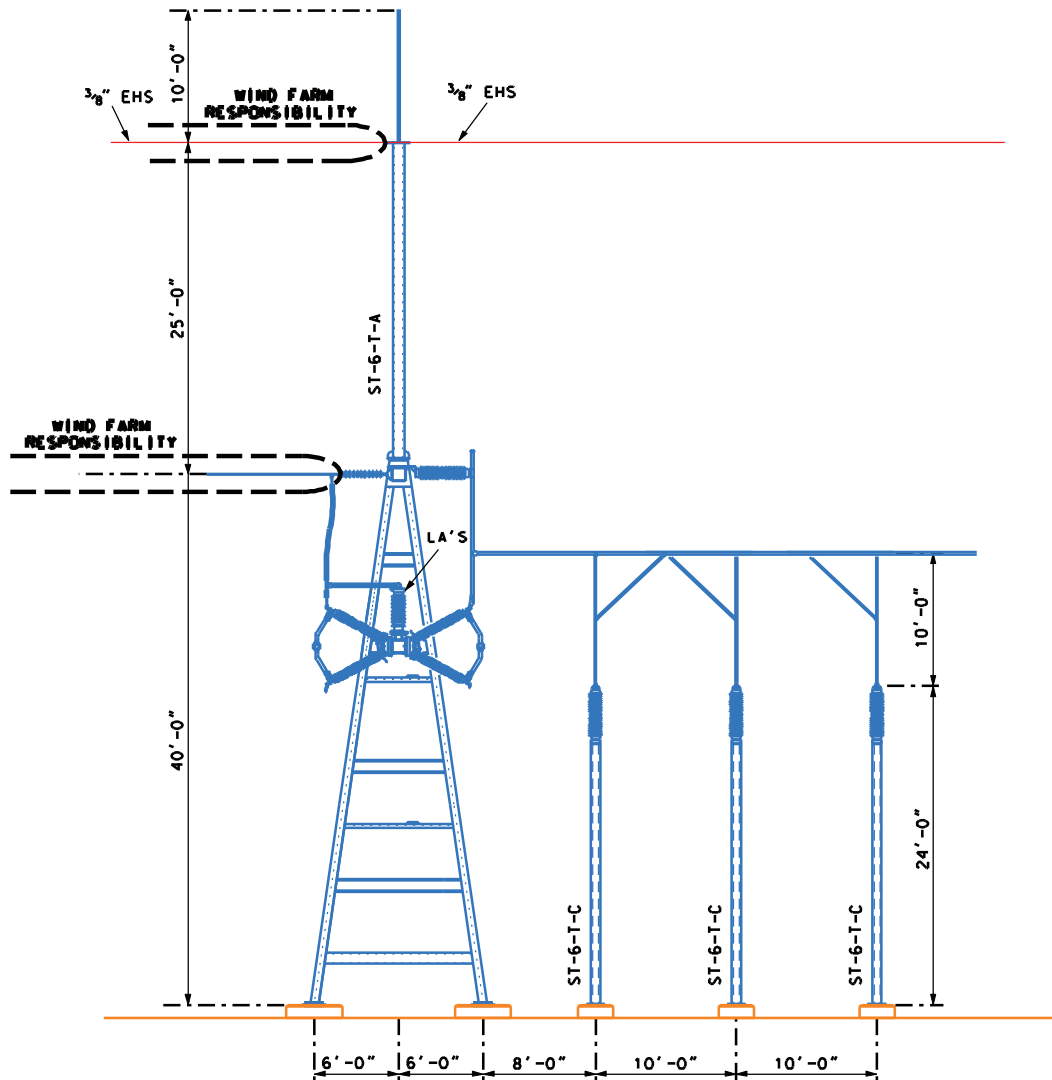

Figure A-1 Wind Farm Interconnection





**FIGURE A-2
POINT OF INTERCONNECTION**

Figure A-2 Point of Interconnection and Change of Ownership

**Appendix B
To Agreement**

Milestones – ~~Amended July~~ August 2008

<u>Action</u>	<u>Responsible Party</u>	<u>Completion Date</u>
Complete Facilities Study	Transmission Provider	02/19/04
Obtain Governmental Authorization	Transmission Owner	N/A
Provide authorization to proceed with design and procurement	Interconnection Customer	01/01/05
Provide financial security for design and procurement (\$50,000)	Interconnection Customer	01/01/05
Provide authorization to proceed with construction	Interconnection Customer	03/01/2005
Provide financial security for construction (\$563,949)	Interconnection Customer	03/01/2005
Complete Transmission Owner’s Interconnection Facilities	Transmission Owner	10/21/2005
In Service Date	Interconnection Customer	10/21/05
Energize Interconnection Customer’s Interconnection Facilities	Interconnection Customer	11/01/2005
Initial Synchronization Date; Begin Trial Operation	Interconnection Customer	11/01/2005
Projected commercial operation date	Interconnection Customer	12/01/2005

<u>Action</u>	<u>Responsible Party</u>	<u>Completion Date</u>
<u>Complete Facilities Study</u>	<u>Transmission Provider</u>	<u>02/19/2004 - Completed</u>
<u>Suspension Notice</u>	<u>Interconnection Customer</u>	<u>02/11/2005</u>
<u>Unsuspending Notice</u>	<u>Interconnection Customer</u>	<u>02/08/2008</u>
<u>Provide authorization to proceed with design of Transmission Owner Interconnection Facilities to be constructed by Transmission Owner per Article 5.5.2</u>	<u>Interconnection Customer</u>	<u>01/09/2009</u>
<u>Provide payment of \$100,000 for engineering design of Transmission Owner Interconnection Facilities</u>	<u>Interconnection Customer</u>	<u>01/09/2009</u>
<u>Provide payment for the procurement of Transmission Owner Interconnection Facilities in the amount of \$150,000</u>	<u>Interconnection Customer</u>	<u>06/15/2009</u>
<u>Obtain Governmental Authorization (as necessary)</u>	<u>Interconnection Customer</u>	
<u>Provide authorization to proceed with construction of Transmission Owner Interconnection Facilities</u>	<u>Interconnection Customer</u>	<u>01/08/2010</u>

<u>Action</u>	<u>Responsible Party</u>	<u>Completion Date</u>
<u>to be constructed by Transmission Owner per Article 5.6.3</u>		
<u>Provide payment of \$248,580 for construction of Transmission Owner Interconnection Facilities to be constructed by Transmission Owner.</u>	<u>Interconnection Customer</u>	<u>01/08/2010</u>
<u>In-Service Date for Transmission Owner Interconnection Facilities</u>	<u>Transmission Owner</u>	<u>06/30/2010</u>
<u>In-Service Date & energization of Interconnection Customer's Interconnection Facilities</u>	<u>Interconnection Customer</u>	<u>08/01/2010</u>
<u>Initial Synchronization Date</u>	<u>Interconnection Customer</u>	<u>09/01/2010</u>
<u>Begin trial operation & testing per Article 6.1</u>	<u>Interconnection Customer & Transmission Owner</u>	<u>09/01/2010</u>
<u>Commercial operation date</u>	<u>Interconnection Customer</u>	<u>12/31/2010</u>
<u>Final accounting of costs incurred by Transmission Owner for construction of Transmission Owner Interconnection Facilities</u>	<u>Transmission Owner</u>	<u>To be submitted within six months of Completing Construction of the Transmission Owner Interconnection Facilities and Network Upgrades</u>

Appendix C To Agreement

Interconnection Details

General: Transmission Provider, Transmission Owner, and Interconnection Customer agree that the Generating Facility cannot be, and is not equipped with Power System Stabilizers.

Transmission Provider, Transmission Owner, and Interconnection Customer agree that the operation of the Generating Facility with the proposed General Electric (GE) wind turbine generators with reactive power control capable of controlling the interconnection power factor shall satisfy the power factor requirements stated as follows. Over the full range of the wind farm's generating capacity, the power factor at the point of interconnection shall be within the range of 0.98 (generation absorbing VARS) to a 0.95 (generation supplying VARS) to the Transmission Owner's transmission system.

In order to accommodate possible minor changes in operating conditions, SPP, or the Transmission Operator may permit, at its sole discretion, adjustments to the specified limits.

-

Facility: The Interconnection Customer's Wind Energy Project is a new wind energy generation facility located approximately 3 miles east of Guymon, Oklahoma. The new wind energy generation facility will interconnect the 150 MW wind facility to the transmission on a new 115kV transmission line tied to Texas County Interchange. The new wind energy project's 115/34.5 kV interconnection substation will be located approximately 2 miles east of Guymon, Oklahoma. The 115/34.5 kV transformer will have a grounded wye connection on the 115 kV. This wind energy project will consist of 100 General Electric (GE) wind turbines with a nominal output of 1.5 MW each, for a nominal output of 150 MW.

Point of Interconnection: The Interconnection Customer's 115kV line will terminate at Transmission Owner's ~~to their self-supporting~~ steel dead-end structure just ~~inside~~outside the Texas County Interchange fence. Interconnection Customer~~Xcel Energy~~ will terminate the ~~Interconnection Customer's~~ 115kV line with a single slack span of 795MCM ACSR conductor with 3/8" EHS static wire from the Interconnection Customer's~~Requester's~~ dead-end structure to the Transmission Owner's Texas County Interchange steel dead-end structure. The line terminals will be designed to accommodate 2,000 pounds per phase conductor at maximum tension heavy-load and two shield wires designed to accommodate 2,000 pounds each at maximum tension heavy-load. The point of interconnection will be the connection between the Interconnection Customer's phase conductors terminated on their dead-end structure located just outside the Texas County Interchange fence, and the slack-span jumper. See Figure A-1, Wind Farm Interconnection and Figure A-2, Point of Interconnection in Appendix A.

Revenue Metering: At Texas County Interchange, Transmission Owner~~Xcel Energy~~ will install on the line to the Interconnection Customer's wind farm, billing meters with a 115 kV CTs for

full 3 phase 4-wire metering. There will be two meters: one will be primary and the other will be back-up, each will have full 4 quadrant metering. Metering pulses will be sent via SCADA to the Transmission Owner's Control Center in Amarillo, Texas.

Relay and Protection Scheme: On the 115kV line from Texas County Interchange to the Interconnection Customer's owned line, relaying will be step distance where a SEL 321-1 and SEL 311-C relays will be used. A SEL 279H-2 relay will be installed for line/bus conditions and sync check along with supervisory closing of the breaker. There will not be any automatic reclosing. A SEL 501-0 will be used for breaker failure.

[Generator Under-frequency Response: SPP has a coordinated regional under-frequency load shedding and restoration plan. The requirements of that plan are detailed in SPP Criteria. The Interconnection Customer agrees that the under-frequency relay instantaneous trip setting shall be set not higher than the 58.5 Hz.](#)

OPERATING GUIDELINES

SWITCHING AND TAGGING PROCEDURES

1. Definitions

- 1.1 CLEARANCE - The process of removing and holding a transmission line, section of bus or piece of equipment from service so that work may be safely performed.
- 1.2 CLEARANCE TAG - The formal registered tag in the Transmission Owner's Switching Procedures document. It is applied at the switches and disconnects through which electrical energy may be supplied to the section of line or equipment at which safety CLEARANCE is desired. It may be used with proper authority and registration at all voltage levels. A CLEARANCE TAG is NEVER used to hold circuits or equipment IN service.

2. Planned Clearance Request in the Facility Originated by Interconnection Customer

- 2.1 If the switching on the Facility requires switching of equipment owned by the Interconnection Customer and controlled by SPP or Transmission Owner, then the Interconnection Customer will send a Clearance Request to the Transmission Owner's or SPP's Transmission System operator to facilitate the switching.

3. Planned Clearance Request originated by Interconnection Customer

- 3.1 Any planned switching originated by the Interconnection Customer which requires switching of equipment controlled by SPP or Transmission Owner, will be coordinated with a Clearance Request through the Transmission Owner's transmission system operator with a minimum of 24 hours notice except in emergency situations (notices of between 24 hours and ten days may be required depending on the impact of the outage on the transmission grid). The Transmission Owner's transmission system operator will accommodate the request as soon as practicable. Personnel availability and system conditions may prevent a Clearance Request from being completed. The Interconnection Customer personnel will perform all switching and apply all CLEARANCE TAGS to equipment owned by the Interconnection Customer in the Interconnection Customer's substation. Transmission Owner personnel may observe the switching if desired.

4. Planned Clearance Request in the Interconnection Customer's Facilities originated by the Transmission Owner

- 4.1 All planned Clearance Requests on the Facility, which requires switching of equipment controlled by the Interconnection Customer and originated by SPP or Transmission Owner, will be coordinated with the Interconnection Customer's personnel by a Clearance Request submitted by Transmission Owner personnel

with a minimum of 48 hours notice except in emergency situations. The Interconnection Customer will accommodate the request as soon as practicable. All switching and application of CLEARANCE TAGS on equipment owned by Interconnection Customer, in the Interconnection Customer's Facilities, will be performed by the Interconnection Customer's personnel. Transmission Owner personnel will be allowed to observe all switching if desired. Once the Interconnection Customer's operator is assured that all devices are properly opened and tagged, the Interconnection Customer's personnel will provide CLEARANCE to the Transmission Owner's Transmission System Operator.

5. Planned Clearance Request originated by Transmission Owner

- 5.1 Interconnection Customer will be notified for informational purposes only of any planned Clearance Request on the Transmission System that do not require total isolation of the Interconnection Customer Facilities.
- 5.2 Any planned Clearance Requests that would result in the isolation of the Interconnection Customer Facilities from the Transmission System or in a reduction in interconnection capacity will be coordinated with the Interconnection Customer.

6. Unplanned Requests To Isolate Interconnection Customer Facilities By Remote Breaker Operations

- 6.1 Interconnection Customer may request the Transmission Owner's transmission system operator to isolate the Interconnection Customer Facilities from the Transmission Owner's system by remote opening breakers. The Transmission Owner's transmission system operator will accommodate the request as soon as practicable. System conditions may prevent such a request from being completed. Clearance will not be given and the Interconnection Customer's personnel must isolate the Interconnection Customer Facilities before starting work. If Clearance is required then request must be made under the procedures of Section 3.1 above.

7. Unplanned Outages

- 7.1 If an unplanned interruption occurs in either the Facility or the Transmission System, both the Transmission Owner's transmission system operator and the Interconnection Customer's personnel will provide the other with all pertinent information. This information will include, but may not be limited to:
 - 1. the devices involved,
 - 2. present status of devices in question,
 - 3. time stamps,
 - 4. cause of interruption (if available),
 - 5. relay targets (if available),
 - 6. any information helpful in determining cause and/or useful in the

restoration process

8. **Re-energization**

Procedures for Re-energizing Interconnection Customer's Facilities after Isolation from the Transmission Owner's System

8.1 Interconnection Customer's personnel must request the Transmission Owner's transmission system operator to re-energize the Interconnection Customer Facilities after they have become isolated.

9. **Emergency Switching**

Emergency Switching to Isolate the Interconnection Customer's Facilities from the Transmission Owner's System

9.1 During emergency situations, Transmission Owner's personnel may request Interconnection Customer's personnel to disconnect the generators at the Facility or Transmission Owner may disconnect generator remotely at the point of interconnect.

10 **Communications Requirements**

10.1 Interconnection Customer's operating personnel will notify the Transmission Owner's System Operator of the following:

- Prior to synchronization of when the Facility commences operation;
- Prior to the Facility ceasing operations;
- As soon as possible after an unplanned separation of all generators;
- For Clearance Requests for Interconnection Customer's equipment requiring switching on the Transmission Owner's system; and
- When abnormal system conditions are affecting the operation of the Interconnection Customer Facilities.

10.3 The Transmission Owner's System Operator will notify Interconnection Customer's operating personnel:

- When conditions may prevent generator synchronization;
- When conditions may require generator separation;
- On a requirement for generator separation;
- On the requirement for redispatch during a System Emergency; and
- For Clearance Request for Transmission Owner's operated equipment requiring switching on the Interconnection Customer's Interconnection Facilities.

10.4 Interconnection Customer's operating personnel will also be required to provide hourly meter readings (MWH and MVar) to the Transmission Owner's System Operator in the event of a telemetry failure from the Interconnection Facilities. This will occur at least once per day before 9:00 a.m. Central time.

10.5 It is also anticipated that the Transmission Owner's System Operator, SPP and Interconnection Customer's operating personnel will communicate, beyond the notices as listed above, as necessary and appropriate, in accordance with Good Utility Practice, to provide reliable and efficient operation of both the Transmission Owner's system and the Interconnection Customer's Facilities.

Appendix D To Agreement

Security Arrangements Details

Infrastructure security of Transmission System equipment and operations and control hardware and software is essential to ensure day-to-day Transmission System reliability and operational security. FERC will expect all Transmission Providers, market participants, and Interconnection Customers interconnected to the Transmission System to comply with the recommendations offered by the President's Critical Infrastructure Protection Board and, eventually, best practice recommendations from the electric reliability authority. All public utilities will be expected to meet basic standards for system infrastructure and operational security, including physical, operational, and cyber-security practices.

The Parties will cooperate reasonably to comply with the recommendations described in paragraph 1 and to implement the applicable standards. The following communications schematic diagram for the project including the Interconnection Customer, Transmission Provider (Southwest Power Pool, [Inc.](#)) and Transmission Owner (Southwestern Public Service) is provided to assist the Parties in meeting these standards.

Communications Schematic Diagram

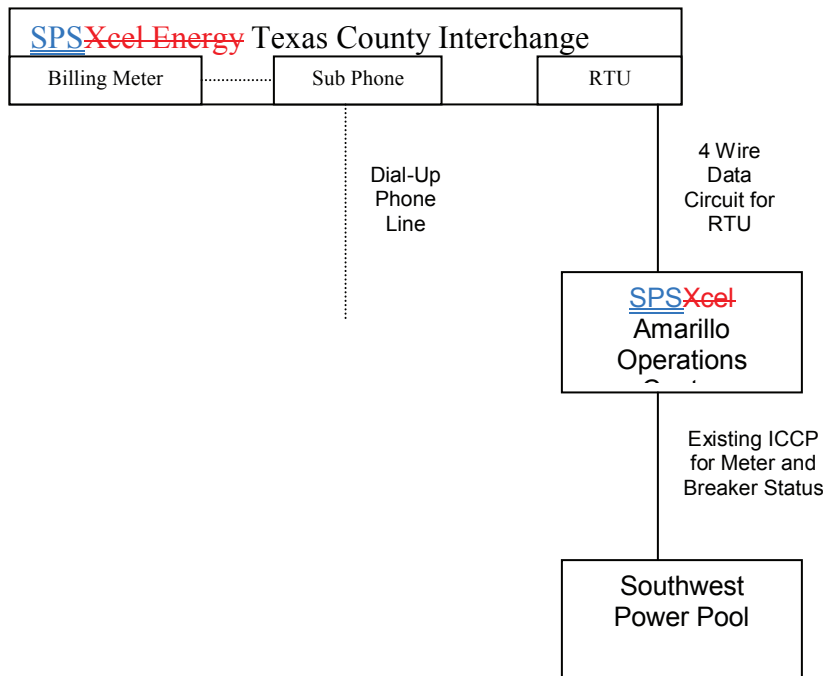

**Appendix E
To Agreement**

Commercial Operation Date

This Appendix E is a part of the Agreement between Transmission Provider, Transmission Owner and Interconnection Customer.

[Date]

Carl Monroe, Executive Vice President and Chief Operating Officer
Southwest Power Pool, Inc.
415 N. McKinley, Suite 140~~800 Plaza West~~
Little Rock, AR 72205
Phone: 501-614-3200
Facsimile: 501-664-9553

Transmission Account Representative
Xcel Energy Services Inc.
6086 W. 48th St.
Amarillo, Texas X 79109

Re: East Guymon Wind Generating Facility

Dear _____:

On **[Date]** East Guymon Wind, LLC has completed Trial Operation of the Generating facility referenced in the Large Generation Interconnection Agreement signed on _____ between East Guymon Wind, LLC, Southwestern Public Service Company, and Southwest Power Pool, Inc.~~Unit No. ____~~. This letter confirms that East Guymon Wind, LLC } commenced Commercial Operation of the referenced~~Unit No. ____~~ at the Generating Facility, effective as of **[Date plus one day]**.

Thank you.

[Signature]

Project Manager
East Guymon Wind, LLC
c/o Edison Mission Energy
18101 Von Karman Ave., Suite 1700
Irvine, CA 92612
~~233 S. Wacker Dr.~~
~~Suite 9450~~
~~Chicago, IL 60606~~

**Appendix F
To Agreement**

Addresses for Delivery of Notices and Billings

Notices:

Transmission Provider:

[Carl Monroe, Executive Vice President and
Chief Operating Officer](#)
~~Carl Monroe, Vice President~~
Southwest Power Pool, Inc.
415 N. McKinley, [Suite 140](#)~~800 Plaza West~~
Little Rock, AR 72205-3020

Transmission Owner:

Transmission Account Representative
Xcel Energy [Services Inc.](#)
6086 W. 48th St.
Amarillo, TX~~exas~~, 79109

Interconnection Customer:

East Guymon Project Manager
East Guymon Wind LLC
[c/o Edison Mission Energy](#)
[18101 Von Karman Ave., Suite 1700](#)
[Irvine, CA 92612](#)
~~e/o Invenergy LLC~~
~~233 S. Waeker Dr.~~
~~Suite 9450~~
~~Chicago, IL 60606~~

Billings and Payments: [Specify addresses for construction invoices, O&M invoices and settlement of ancillary services]

Transmission Provider:

Tony Alexander, Supervisor of Tariff Accounting
~~Carl Monroe, Vice President~~
Southwest Power Pool, Inc.
415 N. McKinley, Suite 140~~800 Plaza West~~
Little Rock, AR 72205-3020

Transmission Owner:

Transmission Account Representative
Xcel Energy Services Inc.
6086 W. 48th St.
Amarillo, TX ~~exas~~, 79109

Interconnection Customer:

Project Manager
East Guymon Wind LLC
c/o Edison Mission Energy
18101 Von Karman Ave., Suite 1700
Irvine, CA 92612
~~233 S. Wacker Dr.~~
~~Suite 9450~~
~~Chicago, IL 60606~~

Alternative Forms of Delivery of Notices (telephone, facsimile or email):

Transmission Provider:

Carl Monroe, Executive Vice President and
Chief Operating Officer
Southwest Power Pool, Inc.
415 N. McKinley, Suite 140~~800 Plaza West~~
Little Rock, AR 72205
Phone: 501-614-3200
Facsimile: 501-664-9553

Transmission Owner:

Transmission Account Representative
Xcel Energy [Services Inc.](#)
6086 W. 48th St.
Amarillo, TX ~~exas~~, 79109
Phone: ~~806-640457~~-6302
Facsimile: ~~806-457-6460~~

Interconnection Customer:

[Project Manager](#)
[East Guymon Wind LLC](#)
[c/o Edison Mission Energy](#)
[18101 Von Karman Ave., Suite 1700](#)
[Irvine, CA 92612](#)
[Phone: ~~949-798-7407~~](#)
[Facsimile: ~~949-225-7228~~](#)
ggriffin@edisonmission.com
~~Project Manager~~
~~East Guymon Wind LLC~~
~~c/o Invenergy LLC~~
~~233 South Wacker Drive, Suite 9450~~
~~Chicago, IL 60606~~
~~Phone: 312.707.9044~~
~~Facsimile: 312.707.9045~~
~~bshueler@inverenergyllc.com~~

Operational Communications:

Transmission Provider:

[Lanny Nickell, Vice President, Operations](#)
Southwest Power Pool, Inc.
415 N. McKinley, ~~Suite 140800 Plaza West~~
Little Rock, AR 72205
Phone: ~~501-614-323200~~
Facsimile: 501-664-9553

Transmission Owner:

SPS Transmission Operator
SPS Amarillo Operations Center
6086 W. 48th Street

Amarillo, TXexas, 79109
Phone: 806-457-6343
Facsimile: 806-457-6349

Interconnection Customer:

Project Manager
East Guymon Wind LLC
c/o Edison Mission Energy
18101 Von Karman Ave., Suite 1700
Irvine, CA 92612
Phone: 949-798-7407
Facsimile: 949-225-7228
ggriffin@edisonmission.com

~~Project Manager~~
~~East Guymon Wind LLC~~
~~c/o Invenergy LLC~~
~~233 South Wacker Drive, Suite 9450~~
~~Chicago, IL 60606~~
~~Phone: 312.707.9044~~
~~Facsimile: 312.707.9045~~
~~bschueler@invenergyllc.com~~

**Appendix G
To Agreement**

Requirements of Generators Relying on Newer Technologies