



Cowal operation

Developing a pathway to produce greater than 300koz per annum



ALL-IN
SUSTAINING
COST

A\$877/oz



FY18
PRODUCTION

257,951oz

www.evolutionmining.com.au

Evolution Mining is a leading, growth focussed Australian gold company. In FY18 Evolution produced 801,187 ounces of gold at an AISC of A\$797 per ounce to reach seven consecutive years of achieving production and cost guidance. Evolution has guided FY19 Group gold production of 720,000 – 770,000 ounces at an All-in sustaining cost of A\$850 – A\$900 per ounce of gold.

The Cowal operation is a sustainable, reliable and low cost production gold operation. The operation is forecast to produce between 240,000 ounces and 250,000 ounces in FY19. In FY19, our challenge is to assess mining and processing options to take this operation to the next level of production excellence – aspiring to an annual production level of 300,000 ounces.

Location: 350km west of Sydney, 40km north-east of West Wyalong

Producing: Gold

Management: Owner operator

Site management: Craig Fawcett - General Manager

Mine Site contact number: +61 2 6975 4700

Cowal had an outstanding year, delivering on projects while achieving above guidance ounces, below guidance costs, and significantly reducing total recordable injury frequency (TRIF) from 7.4 to 3.3.

The site successfully hosted the Evolution and NSW Mine Rescue Challenges in West Wyalong which not only tested our emergency capabilities, but also saw participation from our local community.

A number of mill throughput records were set and a lot of hard work and innovation ensured that the highest throughput for a financial year of 7,795kt was achieved in FY18.

The underexplored region offers immense untapped potential. Exploration delivered material resource growth of 1.35 million ounces of gold prior to mining depletion, setting us up for another strong year and helping to ensure our future at Cowal.

➔ FY18 performance

- Operating mine cash flow - **A\$226M**
- Net mine cash flow - **A\$101M**
- EBITDA margin - **55%**
- Return on invested capital - **23%**
- Stage H cutback - extends mine life to **2032**
- Float tails leach - increase recoveries by **4-6%**
- Plant expansion from 7.5Mtpa to **9.8Mtpa approved**

EXPLORATION SUCCESS DELIVERING ORGANIC GROWTH

Snapshot

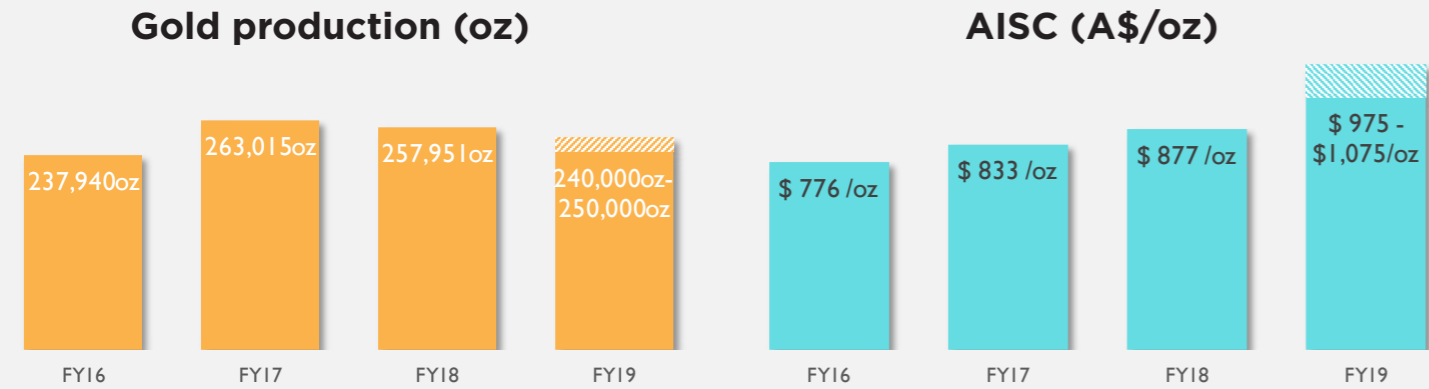

Mineral Resources (Dec 17) Ore Reserves (Dec 17)

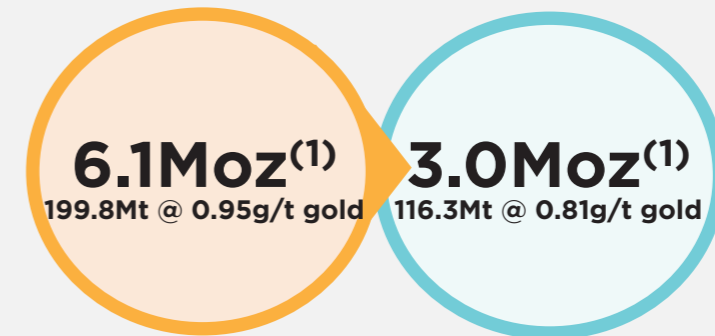

(1) See our website for further details of Cowal's Mineral Resources and Ore Reserves

History - Cowal Evolution

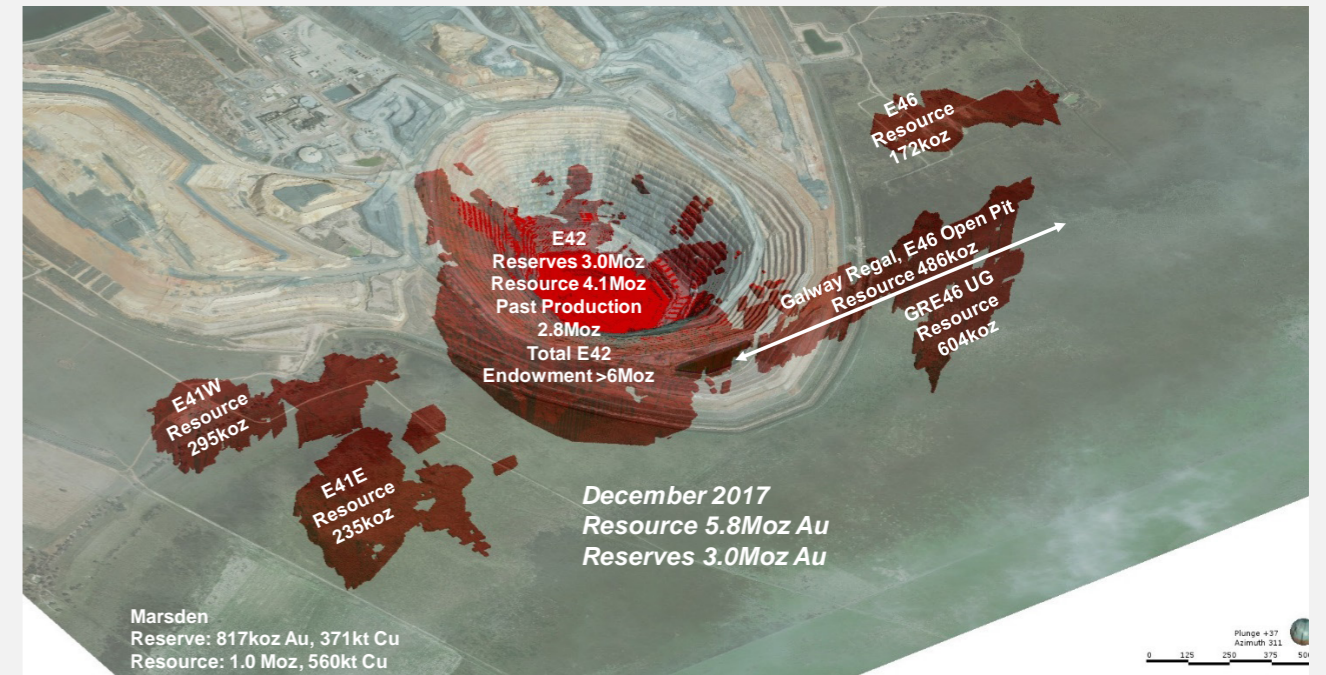
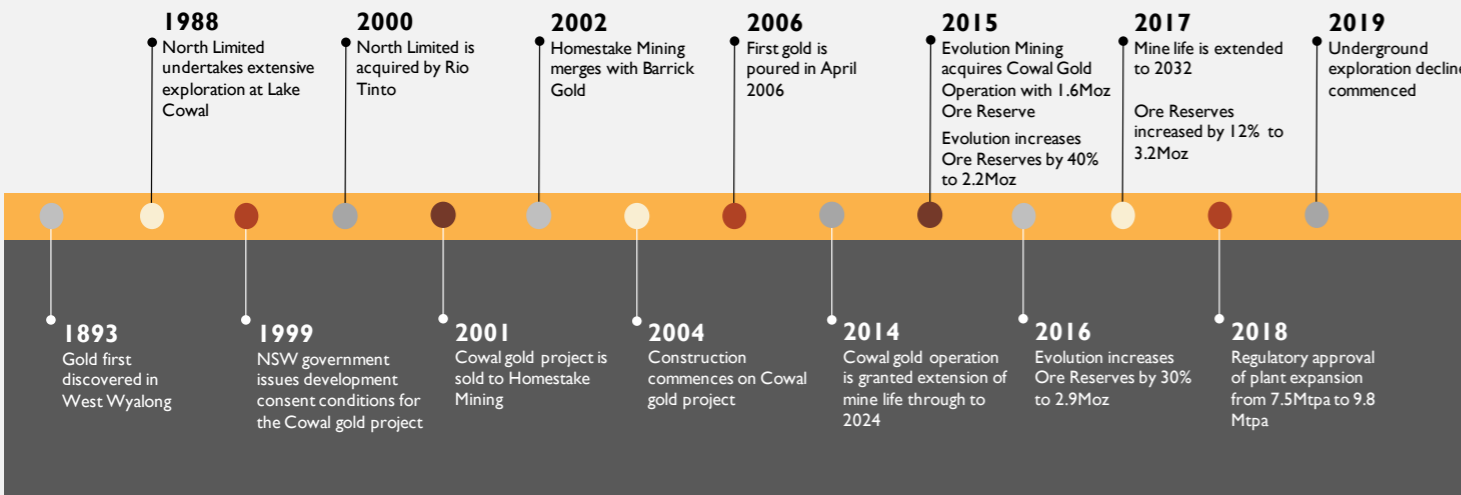

Safety, health and wellness culture

Project Arrive Alive

- Fatigue management identified as a major operational risk
- Industry leading fatigue management policy and practices developed
- Strong emphasis on education and awareness to enable self-regulation
- Enhancement of rosters and journey management
- Supported by fatigue management experts and psychologists
- Project has evolved into a comprehensive employee health and wellness program

Project Vital

- An integrated and holistic approach to employee health and wellness centred on education and awareness
- Utilises expert psychologists (Matecheck) to provide confidential counselling services to employees on a broad range of issues
- Full time health and wellbeing professionals (HBP - Healthy Business) on site – developing personal health plans for employees
- Corporate gym memberships for employees
- Impact on workforce has been profound

Geology

The Cowal gold deposits (E41, E42, E46, Galway, and Regal) occur within the 40km long by 15km wide Ordovician Lake Cowal Volcanic Complex, east of the Gilmore Fault Zone within the eastern portion of the Lachlan Fold Belt. The overall structure of the gold deposits is complex but in general consists of a faulted antiform that plunges shallowly to the north-northeast. The deposits are aligned along a north-south orientated corridor with bounding faults, the Booberoi Fault on the western side and the Reflector Fault on the eastern side (the Gold Corridor).

The E41 West mineralisation strikes north-northeast and dips -70° east, and measures 750m along strike and 250m across strike. Individual mineralised zones are 35m to 50m wide and extend down dip for 125m. The E41 East mineralisation strikes east-west and dips -35° to -80° south, and measures 475m along strike and 500m across strike. Individual mineralised zones are 35m to 50m wide and extend down dip for 225m. The E42 deposit comprises the Regal/Galway corridor and the E42 Main Zone. The Regal/Galway corridor trends north-south, dips vertical to -70° west, and is composed of small and discontinuous lenses. The corridor is approximately 900m along strike and 200m wide. The E42 Main Zone trends north-south and dips -35° to -45° west.

The two principal domains in the E42 Zone are separated by the Cowal Fault. Overall, the E42 Main Zone mineralisation is approximately 850m by 850m and extends 500m down dip.

The E46 deposit is subdivided into the East and West zones. The East zone is a continuation of the Regal/Galway corridor, trends north-south, dips vertical to -70° west, and extends approximately 750m along strike and 175m across strike. Individual lenses in the E46 East mineralised zone are 1.0m to 15m wide, 25m to 250m long, and extend 50m to 200m down dip. The E46 West mineralisation trends north-northeast, dips -40° west to flat-lying, and measures approximately 650m along strike and 17m across strike. Individual zones are approximately 50m wide and extend 200m down dip.

Discovery

The Cowal operation is on mining lease ML1535 and encompasses an area of 2,636 hectares and lies within Evolution's total property holding of ~13,152 hectares.

Near Mine Growth

GRE46

Following on from the success of converting the Stage H resource to reserves, exploration drilling turned its attention to the Galway-Regal-E46 (GRE46) corridor. We announced a maiden Inferred underground resource at GRE46 (603,000 gold ounces) and demonstrated the potential to expand the underground mineralised zone. A further 206,000 resource ounces were identified at E41 and GRE46 open pits.

Step-out drilling confirmed high-grade mineralisation is open along strike and identified the high-grade Dalwhinnie lode located 30 to 50 metres into the footwall of the GRE46 underground resource. An underground exploration decline has been approved and development commences in March 2019. We believe there is sufficient untested area to support resource growth of more than 500,000 ounces, bringing the endowment to greater than one million ounces at GRE46.

E41

The E41 deposit represents a strong opportunity to continue baseload open pit feed to Cowal's production profile as mineralisation is constrained by drilling, not by geology. Drilling at E41 West identified a new and significant zone of mineralisation over 250m in length outside of the resource, along strike and at depth.

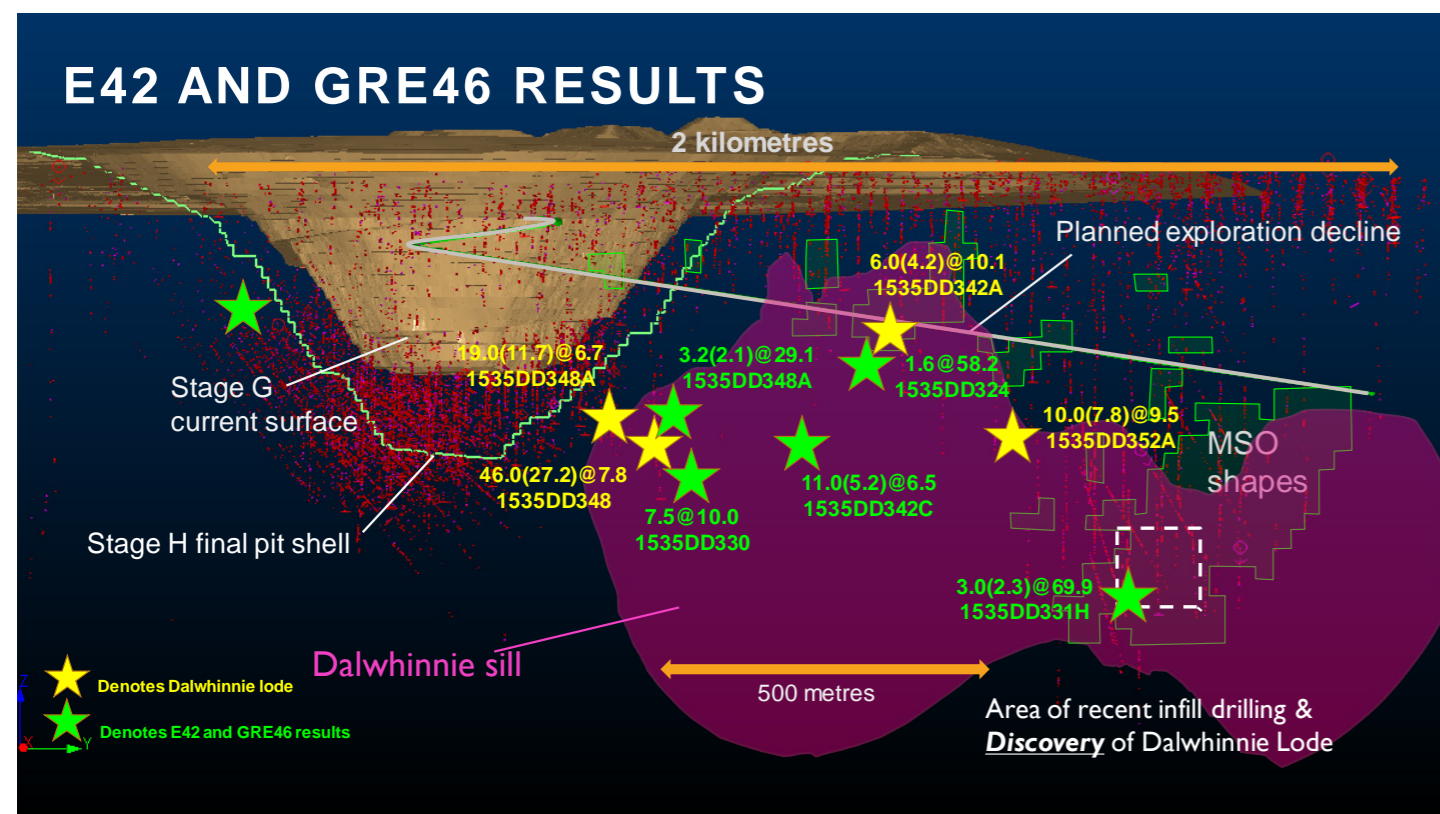

Regional Opportunities

Marsden – reserve conversion

Marsden is a copper-gold porphyry deposit located immediately to the southeast of the operation. In FY18, we announced

a maiden Ore Reserve of 817,000 gold ounces and 371,000 copper tonnes. Marsden has longterm strategic value to our exploration activities in the area and highlights the copper-gold opportunity in the Cowal district.

East Girral

An unexplored structure northwest of the mine was identified as highly prospective. Subsequent aircore drilling in FY18 delineated a significant geochemical anomaly and follow up drilling is planned.

Mining

The Cowal operation is an open pit mining operation utilising conventional drill and blast, load and haul methodologies, mining nominally 9m benches as 3 x 3m flitches. Mining commenced in 2005 and processing started in 2006. Mining is carried out with a company-owned fleet of mining equipment. Ore is hauled by truck from the pit face to either a stockpile area or directly fed into the primary crusher.

The operation is scheduled to continue until FY25 and the processing until FY33 at current estimates. The LOM strip ratio is currently 1.27:1.

Ore mined: 7.8Mt (FY18) 10.2Mt (FY17) 7.7Mt (FY16)

Waste mined: 1.6Mt [16.6Mt Capital waste] (FY18) 2.1Mt (FY17) 4.0Mt (FY16)

Mine work roster: 7/7

Explosives: AN suspension / Daveytronic & Nonel detonation

Blasting contract services: Maxam Australia P/L

Mine survey equipment/products: Surpac / Trimble survey equipment

Geotechnical equipment products: MineSight, Prism monitoring

Mine planning software: Surpac, MineSched, Whittle

Mining fleet

Haulage/mine trucks

16 x Cat 789C Dump Trucks

5 x Cat 785 Dump Trucks

Drilling equipment

3 x Atlas Copco D65 (Hired)

1 x Terex SKF Drill

Dozers

5 x CAT D10T Tracked Dozers

1 x CAT834H Wheel Dozer

Shovels/excavators/loaders

1 x Liebherr 9400 Excavator

1 x Liebherr 994B Excavator

1 x Hitachi EX3600 Excavator

1 x Hitachi EX1200 Excavator

2 x Cat 992G Loaders

Haul road maintenance equipment

3 x Cat 16H Graders

1 x Cat 349 Excavator

2 x Cat 777D Water Carts

Processing

The Cowal processing plant was commissioned in May 2006 and consists of crushing, two stage grinding, sulphide flotation, regrind and CIL recovery. The plant currently processes 7.5 Mtpa (nameplate capacity - 6.4Mtpa) and a crushing plant total capacity of 1,800tph.

At 30 June 2018 over three million ounces of gold had been produced at Cowal.

Power supplied by AGL

Crushing

Primary crushing: Metso 54-75 Superior MK-II gyratory crusher

Grinding

FFE 36' x 20.5' SAG mill, FFE 22' x 36.5' ball mill
Forged steel 125mm balls (SAG), 80mm balls (ball mill)

Screening

Schenck Vibrating screens (SAG discharge), Delkor Linear (COF)

Recycle crusher

2 x Sandvik H6800 hydrocone cone crushers

Mineral liberation/recovery

Method: flotation, regrind, CIL of concentrate
Equipment: 2 x SK1200 and 10 x OK200TC (flotation), Metso Vertimill (VTM1000WB), 2 x Metso 355kW SMDs, Pre-ox - 4,000m³, 2 x 4,000m³ leach and 6 x 1,000m³ CIL tanks
Cyanide supply – Orica
Lime supply – Boral

Refining

10t AARL elution circuit, ANSAC regeneration kiln

Gravity Circuit

Falcon concentrator / Acacia Reactor

Process flowsheet

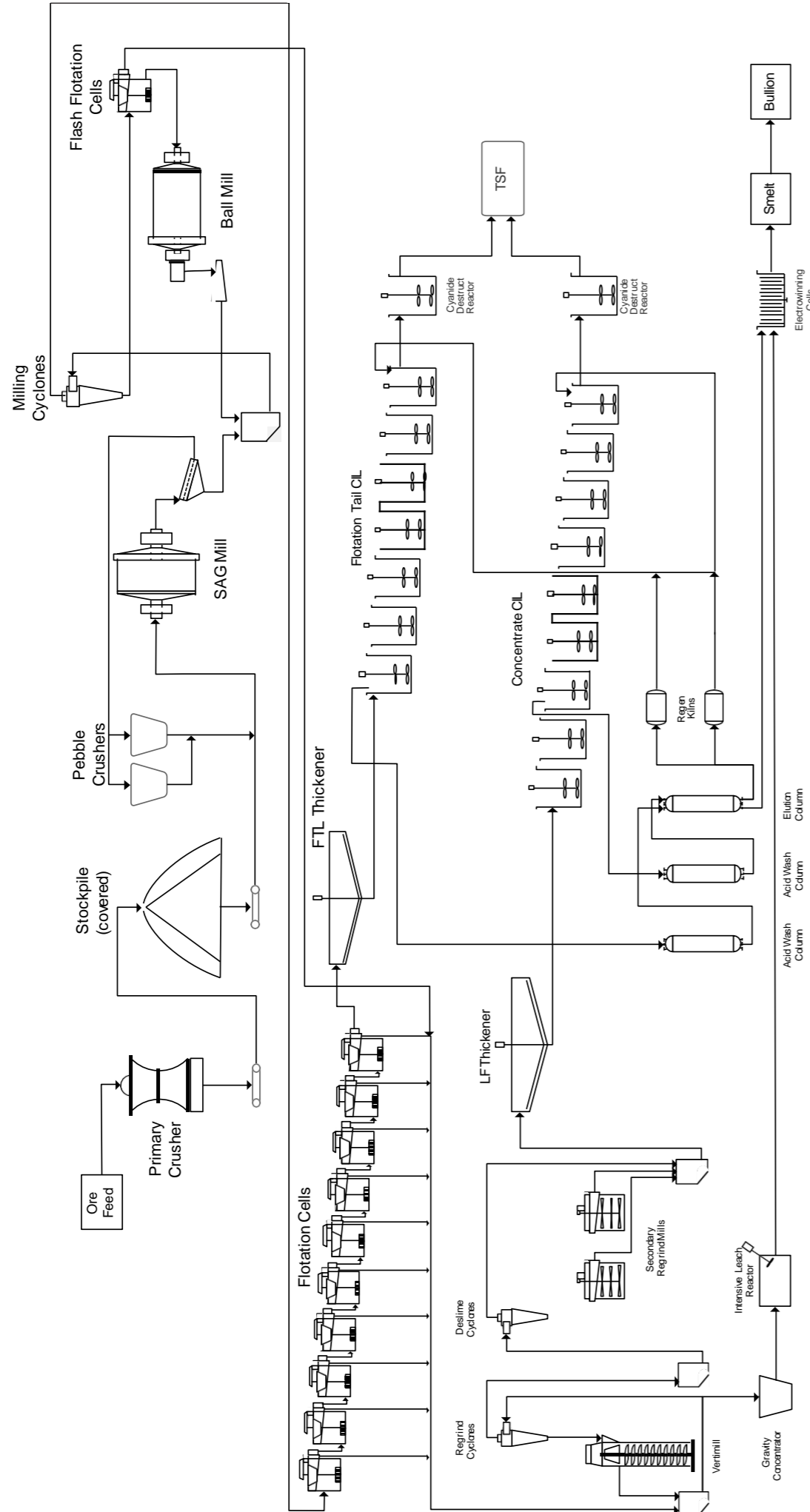

General

- Accommodation**
 Residential accommodation in West Wyalong
- Mine workforce**
 385 - mostly local, employees and contractors
- Safety / Environment / Community**
 Evolution strives to enable all work activities related to its operations to be carried out safely and with all reasonable measures taken to remove or reduce risks to the health, safety and welfare of personnel, plant and equipment. Evolution is committed to attaining an outstanding level of environmental performance in all of its workplaces and has a strong corporate culture and a commitment to proactively and positively engage with the communities in which we operate. We recognise the need to consult with and understand the values, needs, beliefs, traditions and sensitivities of the communities in which we operate

Safety

Our core value of safety is critical to our success as a Company. Evolution remains focused on improving our high safety standards across our business. At 30 September 2018, Cowal's total recordable injury frequency (TRIF) was 4.0. Our key focus areas are supervisor engagement, contractor competencies and skills training.



Environment

We are committed to attaining an outstanding level of environmental performance in all our workplaces. Evolution incorporates environmental considerations into all areas of our business to effectively manage environmental impacts and risks. We have developed an Environment and Sustainability Policy that we expect our people and contractors to adhere to. Cowal operations are ISO14001 certified for mining and ore processing operations and support services for gold and silver production.

We believe we have an obligation to not only achieve legislative compliance but to strive for best practice and to meet the expectations of the communities we operate within and are part of. We are focussed on enhancing environmental stewardship through the implementation of our environmental protocols and life of mine environmental management plans across all project sites. For further information please go to our website, www.evolutionmining.com.au.

Community

Our Cowal operation sits within the Bland, Lachlan and Forbes Shires on the traditional lands of the Wiradjuri people. Evolution is committed to building relationships with our community stakeholders based on trust, mutual respect and genuine partnership. We want the communities in which we operate to be better off overall for us having been there. Underpinning this is our desire to always leave a positive legacy.

We are committed to investing in our communities and partnering to achieve meaningful outcomes and to generate shared value. We share the economic benefit by, wherever possible, prioritising local procurement and local employment and training opportunities, particularly for our local indigenous communities.

Our strong community support includes:

- Partnership with Wiradjuri Condobolin Corporation (WCC)
- Total local procurement spend of ~A\$28M per annum
- Supporting local charities and sports clubs
- ~75% of employees are permanent residents
- ~6% of employees are Indigenous

