



### Features

- Drives External Power MOSFET
- Low LED Current (2.5mA)
- Requires No External Power Supply
- Load Voltages up to 65V
- High Reliability
- Small 8-pin Surface Mount Package
- 3750V<sub>rms</sub> Input/Output Isolation

### Applications

- Industrial Controls
- Instrumentation
- Medical Equipment Isolation
- Electronic Switching
- I/O Subsystems
- Appliances

### Approvals

- UL recognized component: File # E76270

### Description

The CPC1580 optical gate driver provides isolated control of a discrete power MOSFET transistor without the need of an external power supply. Control of the power MOSFET transistor is accomplished by the application of sufficient input LED current to activate the driver circuitry.

On the load side, an external storage capacitor and an internal bootstrap diode enable the internal photovoltaic and gate driver circuitry to provide fast output switching characteristics by supplying the charge necessary to satisfy the MOSFET's bias requirements.

Provided in a small 8-pin package, the CPC1580 provides 3750V<sub>rms</sub> of input-to-output isolation.

### Ordering Information

Part	Description
CPC1580P	8-Pin Flatpack (50/Tube)
CPC1580PTR	8-Pin Flatpack (1000/Reel)

Figure 1. CPC1580 Application Circuit Diagram

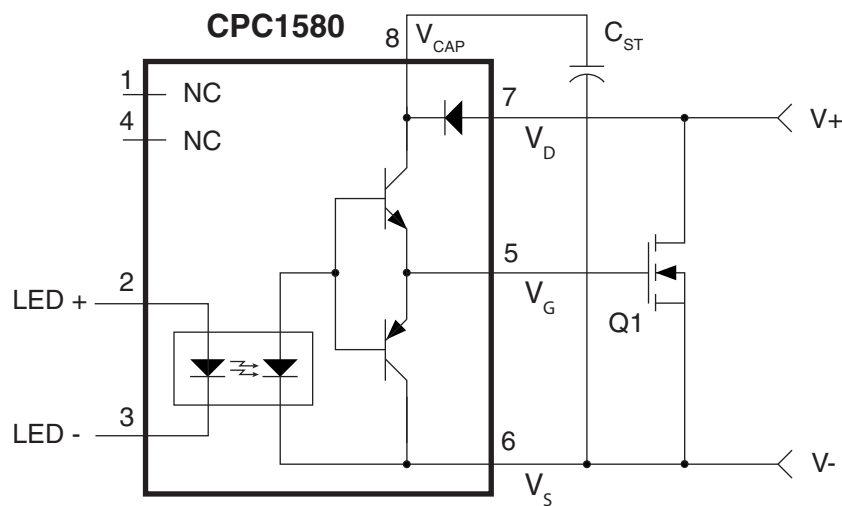

**1. Specifications** ..... 3

- 1.1 Package Pinout ..... 3
- 1.2 Absolute Maximum Ratings ..... 3
- 1.3 Pin Description ..... 3
- 1.4 ESD Rating ..... 3
- 1.5 General Conditions ..... 4
- 1.6 Electrical Specifications ..... 4
- 1.7 Performance Data ..... 5

**2. Introduction** ..... 6

**3. External Part Selection** ..... 6

- 3.1 Storage Capacitor Selection ..... 6
- 3.2 Transistor Selection ..... 7
  - 3.2.1 Transistor Switching Characteristics ..... 7

**4. CPC1580 Over-Voltage Protection** ..... 8

- 4.1 Other Protection Techniques ..... 8

**5. Application Switching Losses** ..... 9

- 5.1 Resistive Load Losses: The Ideal Case ..... 9
- 5.2 Inductive/Resistive Loads ..... 9
- 5.3 Capacitive Loads ..... 9
- 5.4 dV/dt Characteristics ..... 9

**6. Design Switching Frequency** ..... 10

**7. Manufacturing Information** ..... 11

- 7.1 Soldering ..... 11
- 7.2 Washing ..... 11
- 7.3 Mechanical Dimensions ..... 11
- 7.4 Tape and Reel Specification ..... 11

Preliminary

## 1. Specifications

### 1.1 Package Pinout

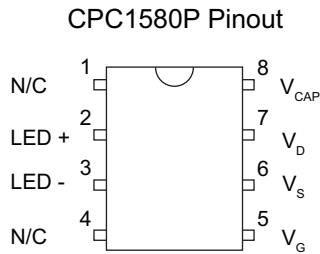

### 1.3 Pin Description

Pin#	Name	Description
1	N/C	Not connected
2	LED +	Positive input to LED
3	LED -	Negative input to LED
4	N/C	Not connected
5	$V_G$	Output, MOSFET Gate Control
6	$V_S$	MOSFET Source Voltage
7	$V_D$	MOSFET Drain Voltage
8	$V_{CAP}$	Storage Capacitor

### 1.2 Absolute Maximum Ratings

Parameter	Rating	Units
Blocking Voltage ( $V_{DS}$ )	65	$V_P$
Reverse Input Voltage	5	V
Input Control Current	50	mA
Peak (10ms)	1	A
Input Power Dissipation <sup>1</sup>	150	mW
Output Power Dissipation <sup>2</sup>	500	mW
Isolation Voltage (Input to Output)	3750	$V_{rms}$
Operational Temperature	-40 to +110	°C
Storage Temperature	-40 to +125	°C

<sup>1</sup> Derate linearly 1.33mW/°C

<sup>2</sup> Derate linearly 6.0mW/°C

Absolute maximum electrical ratings are at 25°C

*Absolute maximum ratings are stress ratings. Stresses in excess of these ratings can cause permanent damage to the device. Functional operation of the device at conditions beyond those indicated in the operational sections of this data sheet is not implied.*

### 1.4 ESD Rating

ESD Rating (Human Body Model)
1000 V

## 1.5 General Conditions

Unless otherwise specified, minimum and maximum values are guaranteed by production testing.

Typical values are characteristic of the device at 25°C and are the result of engineering evaluations. They are

provided for informational purposes only and are not part of the manufacturing testing requirements.

Unless otherwise noted, all electrical specifications are listed for  $T_A=25^\circ\text{C}$ .

## 1.6 Electrical Specifications

Parameter	Conditions	Symbol	Min	Typ	Max	Units
<b>Load Side Characteristics</b>						
Gate Voltage	$I_F=2.5\text{mA}$	$V_{GS}$	7.5	8.2	12	V
	$I_F=5\text{mA}$			8.7		
	$I_F=10\text{mA}$			9.1		
	$I_F=2.5\text{mA}$ $-40^\circ\text{C}<T_A<110^\circ\text{C}$		4.2	-	14.4	
Capacitor Voltage	$10\text{V}<V_{DS}<65\text{V}$	$V_{CAP}$	$V_{DS}-0.8$	-	$V_{DS}-0.2$	V
Gate Drive Capability	$I_F=2.5\text{mA}, V_{GS}=0\text{V}, V_{CAP}=15\text{V}$	$I_{G\_source}$	2	3.6	7	mA
	$I_F=0\text{mA}, V_{GS}=8\text{V}, V_{CAP}=8\text{V}$	$I_{G\_sink}$	0.35	0.47	1	
	$I_F=0\text{mA}, V_{GS}=4\text{V}, V_{CAP}=4\text{V}$		0.16	0.22		
	$I_F=0\text{mA}, V_{GS}=2\text{V}, V_{CAP}=2\text{V}$		0.06	0.09		
Turn-On Delay	$V_{DS}=48\text{V}, V_{GS}=4\text{V}, C_{VG}=4\text{nF}$	$T_{ON}$	1			$\mu\text{s}$
	$I_F=2.5\text{mA}$			48	140	
	$I_F=5\text{mA}$			16	40	
	$I_F=10\text{mA}$			7	20	
Turn-Off Delay	$V_{DS}=48\text{V}, V_{GS}=2\text{V}, C_{VG}=4\text{nF}$	$T_{OFF1}$	40			$\mu\text{s}$
	$I_F=2.5\text{mA}$			150	400	
	$I_F=5\text{mA}$			175		
	$I_F=10\text{mA}$			195		
	$V_{DS}=48\text{V}, V_{GS}=1\text{V}, C_{VG}=4\text{nF}$	$T_{OFF2}$	40			$\mu\text{s}$
	$I_F=2.5\text{mA}$			240		
	$I_F=5\text{mA}$			270		
	$I_F=10\text{mA}$			290		
Off-State Leakage Current	$V_{DS}=65\text{V}$	$I_{DS}$	-	-	1	$\mu\text{A}$
<b>LED Characteristics</b>						
Forward Voltage Drop	$I_F=5\text{mA}$	$V_F$	1	1.27	1.4	V
Input Dropout Current	$V_{GS}=1\text{V}$	$I_F$	0.2	0.7	1	mA
Reverse Bias Leakage Current	$V_R=5\text{V}$	$I_R$	-	-	10	$\mu\text{A}$
<b>Common Characteristics</b>						
Input to Output Capacitance	-	$C_{I/O}$	-	3	-	pF

**1.7 Performance Data**

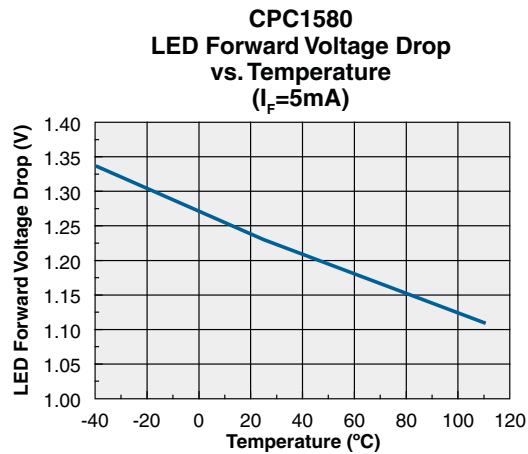
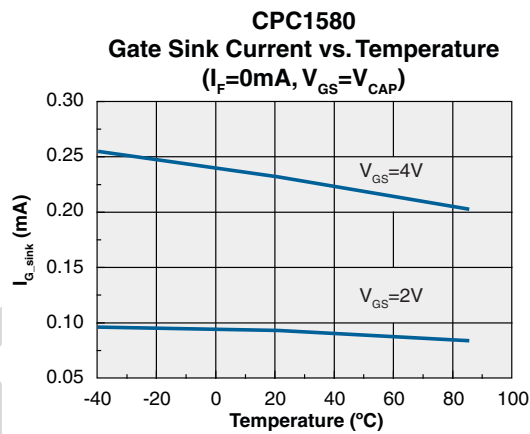
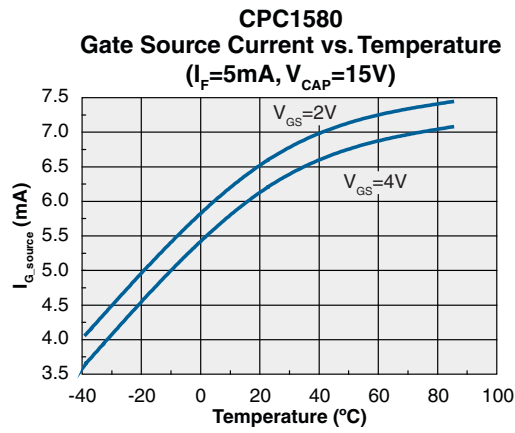

## 2. Introduction

The CPC1580 Isolated Gate Driver uses an efficient optocoupler design to provide remote gate drive current to a MOSFET, while providing 3750V<sub>rms</sub> of isolation between the LED control current input and the MOSFET gate drive output. To make the most efficient use of the input control current to the optocoupler's LED, the CPC1580 has multiple phototransistors in a stacked configuration. As a result, the gate drive current to the attached MOSFET can be switched on with just a small input control current to the LED.

To minimize MOSFET turn-on time, the CPC1580 makes use of an external charge storage capacitor. When control current is applied to the CPC1580 to turn on the MOSFET, the charge held in this capacitor is delivered to the MOSFET's gate, which charges the gate quickly and turns on the MOSFET. After the capacitor charge has turned the MOSFET on and as long as sufficient input control current is applied, the continuing flow of phototransistor current will keep the MOSFET turned on; in other words, there is no lower operating frequency with the CPC1580. When the MOSFET is turned off, the capacitor recharges, through the internal bootstrap diode from the MOSFET power supply, for the next turn-on cycle. In addition, the bootstrap diode prevents the capacitor from discharging through the MOSFET.

The CPC1580 is powered from the system bus supply voltage of the MOSFET, which means that no separate power supply is required. Because of this, circuit design is greatly simplified, circuit complexity is minimized, and added heat and cost are avoided.

By selecting a few external components, the charge capacitor and two resistors, the designer has control over the operating parameters of the CPC1580 circuit, and can customize the circuit to accommodate the requirements of a wide selection of MOSFETs. Overvoltage protection for the CPC1580 can be provided in a number of ways; one is discussed in the remainder of this data sheet along with a description of external component selection.

## 3. External Part Selection

### 3.1 Storage Capacitor Selection

The storage capacitor ( $C_{ST}$ ) enables the part to turn on quickly by holding a reservoir of charge to be transferred to the gate of the MOSFET. The turn-off cycle does not depend on the storage capacitor.

The equation used to calculate the value of the charge storage capacitor is:

$$C_{ST} \geq \frac{Q_G}{V_{LOAD} - V_{CAP}} \quad (\text{FARADS})$$

Where  $V_{CAP} \geq 15V$  and  $Q_G$  is the total gate charge (listed in the MOSFET data sheet).

The storage capacitor needs to deliver enough charge to the gate without going below the 15V required for switching the MOSFET. This means that  $V_{LOAD}$  must equal, at a minimum, 15.7V. The part can operate at a lower voltage, but the MOSFETs will be turned on only partially.

The proper selection of a capacitor is important. The rated voltage should be at least two to three times the  $V_{CAP}$ . The extra margin is important because some capacitors lose capacitance when operated at their full rated voltages. When selecting a capacitor, be sure to add in their tolerance because of capacitor drift. For example:

- $C_{ST} = 1\mu F$ , 20% tolerance;  $V_{CAP} = 15V$
- $1\mu F \times 20\% = 0.2\mu F$
- $1\mu F + 0.2\mu F = \underline{\underline{1.2\mu F}}$

Capacitance drift can also be due to temperature and the dielectrics used. Therefore, the required capacitor value is 1.2 $\mu F$  or next higher value, and the capacitor voltage rating must be at least 30 volts. It is recommended to go higher in the voltage rating if engineering restraints permit, such as 50V. Temperature requirements for capacitors are application-specific. The designer must know the intended operating temperature when selecting capacitors. The information given above should be applied to other capacitors discussed in this data sheet.

The CPC1580 can deliver 32nC at the rated operating speed and will operate with much larger loads (>4 $\mu F$ ) with slower turn-on and turn-off times.

**Note:** Care must be taken to minimize any capacitor-to-ground leakage current path between pins 7 and 8 (MOSFET gate current) and between pins 5 and 6. Leakage currents will discharge the storage capacitor and, even though the device is already on, will become a load to the photocurrent, which keeps the gate voltage on. The gate voltage will be reduced if >500nA of leakage is present, therefore the combined impedance from pin 8 to pin 7, pin 5, and pin 6, capacitor current, and MOSFET current must be >20M $\Omega$  over the temperature rating of the part.

### 3.2 Transistor Selection

The CPC1580 charges and discharges an external MOSFET transistor. The selection of the MOSFET is determined by the user to meet the specific power requirements for the load. The CPC1580 output voltage is listed in the specifications, but as mentioned earlier, there must be little or no gate leakage.

Another parameter that plays a significant role in the selection of the transistor is the gate drive voltage available from the part. The CPC1580 uses photovoltaic cells to collect the optical energy generated by the LED; to generate more voltage, the photovoltaic diodes are stacked. The voltage change of the photovoltaic stack reduces with increased temperature. The user must select a transistor that will maintain the load current at the maximum temperature, given the  $V_{GS}$  in [Section 1.6](#), the CPC1580 Table of Electrical Specifications.

The example circuits shown in [Figure 1](#) and [Figure 2](#) use “logic level” MOSFETs for each design to maintain the load described.

#### 3.2.1 Transistor Switching Characteristics

The primary characteristics of the application switching are  $t_{ON}$ ,  $t_{OFF}$ ,  $t_{RISE}$ ,  $t_{FALL}$ , and the recovery time of the storage capacitor,  $t_{CHG}$ . These parameters are dependent on the MOSFET selection and need to be reviewed in light of the application requirements.

The CPC1580 turns on the MOSFET transistor to the specified  $V_{GS}$  after the  $t_{ON}$  delay. Similarly the  $t_{OFF}$  delay is the amount of time until the LED is turned off and the capacitive load discharges to the level in the CPC1580 specification. For MOSFETs with larger or smaller required gate charge the  $t_{ON}$  and  $t_{OFF}$  will be proportionately faster and slower, but it is not a linear relationship.

To calculate the nominal rise time of the transistor's drain voltage,  $V_D$ :

$$t_{RISE,VD} \approx \frac{V_{LOAD} \cdot C_{RSS}}{I_{G\_SINK}} \quad (\text{SECONDS})$$

To calculate the nominal fall time of the transistor's drain voltage,  $V_D$ :

$$t_{FALL,VD} \approx \frac{V_{LOAD} \cdot C_{RSS}}{I_{G\_SOURCE}} \quad (\text{SECONDS})$$

Where  $C_{RSS}$  is the MOSFET gate-drain capacitance (averaged over the switching voltage range) found in the MOSFET data sheet,  $I_{G\_SINK}$  is the gate sinking current of the CPC1580, and  $I_{G\_SOURCE}$  is the gate driving ability. The maximum value of  $t_{RISE}$  is limited

by the CPC1580 unloaded discharge characteristic and should be reviewed in light of the final application component selections if critical.

The value for the charge time,  $T_{CHG}$ , is due to external component selection. The storage capacitor charge recovery time (seconds) is computed as:

$$t_{CHG} \approx - (400 + R_{OVP}) \cdot (C_{ST} + C_{OVP}) \cdot \ln \left( \frac{(V_{LOAD} - V_{FINAL}) \cdot C_{ST}}{Q_{GATE}} \right)$$

Which reduces to:

$$t_{CHG} \approx - (400 + R_{OVP}) \cdot (C_{ST} + C_{OVP}) \cdot 3$$

$R_{OVP}$  and  $C_{OVP}$  are optional over-voltage protection elements that are present in the application circuit diagram (see [Figure 2](#)).

The term inside the logarithm reflects the discharge and recharge voltage on  $C_{ST}$ . For practical circuit component selection, this can be simplified as described above.

Use this information to calculate the maximum switching frequency in [Section 6](#) below.

**Note:** *The CPC1580 is ideal to use where remote power is otherwise unavailable. If the LED is also powered remotely, care must be taken to ensure that parasitic transient signals are reliably filtered from the input control signal. Large transient currents will mutually couple energy between cables and a simple R-C filtering of the CPC1580 input may be sufficient to suppress false turn-on.*

## 4. CPC1580 Over-Voltage Protection

Over-voltage protection is generally required for the CPC1580 because of parasitic inductance in the load, wires, board traces, and axial leads of protectors. Purely resistive loads or loads with low voltage switching may be able to rely on the transistor to handle any parasitic energy and thereby not require protection for the CPC1580. For very low inductance loads and traces, over-voltage suppression may be handled with a simple R-C filter consisting of  $R_{OVP}$  and  $C_{OVP}$  or by use of a free-wheeling diode (see [Figure 2](#)). For more moderate load inductance, or remote switching of a load (i.e. through a long cable) a voltage suppressor can be used. For heavily inductive loads only a free-wheeling diode,  $D_{OVP}$  connected across the load element is recommended, see [Figure 2](#).

The energy not consumed in switching losses must be absorbed by the over-voltage protection element. Most protective devices are designed to withstand certain peak power, in the case of a Transient Voltage Suppressor (TVS); or maximum avalanche energy, in the case of a MOSFET. Understanding the switching losses and load dynamics is absolutely essential.

One simple way to reduce the amount of stored inductive energy is to increase the energy dissipated in the switch. This can be accomplished by adding a larger capacitor in parallel with the gate-drain connection of the MOSFET, however care must be taken so that the rise time and peak current do not exceed the Safe Operating Area (SOA) rating of the transistor.

The consequence of increasing the gate-drain effective capacitance is reduced dV/dt tolerance.

When used in a circuit with an inductive load, precautions must be taken to prevent damage to the circuit from inductively generated voltage spikes. The circuit shown in [Figure 2](#) includes such protection across the inductive load.

### 4.1 Other Protection Techniques

Switching loads with higher inductance characteristics requires consideration of other circuit protection techniques, device ratings, or protector types. Of paramount importance is that the designer know the characteristics of the load being switched.

**Figure 2. CPC1580 Over-Voltage Protection for Inductive Loads**

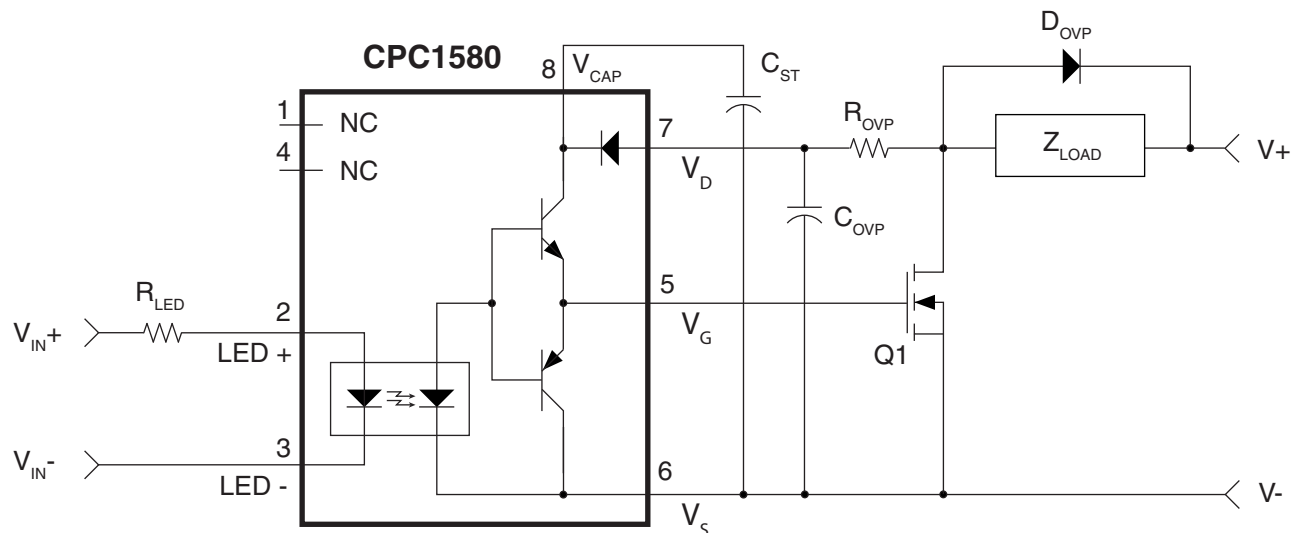



## 5. Application Switching Losses

During the transition intervals, the application and load components change energy states and, in the process, incur switching losses. The switching losses are manifested as heat in the application circuit and must be addressed by the designer to ensure that no one component exceeds its power rating. The designer must understand the details of the load behavior in order to adequately size and protect the application circuit. There are three general cases to observe: (1) purely resistive loads, (2) inductive/resistive loads, and (3) loads with significant capacitance. Inductors and capacitors are energy storage elements that require special consideration for switching.

During the switching periods, energy is conserved. Inductors turning off transfer their stored energy to MOSFET switching losses, to the capacitance of the load and application circuit, and to the protector.

During the turn-on interval, the inductor energy is zero, and so the capacitive energy in the load and parasitic elements of the switching application must be dissipated by the MOSFET, in order for the load to change state.

To calculate the stored inductive energy in Joules:

$$E_L = \frac{1}{2} \cdot L \cdot I_{LOAD}^2$$

### 5.1 Resistive Load Losses: The Ideal Case

For purely resistive loads, the energy dissipated by changing states occurs primarily in the MOSFET.

The equation describing MOSFET energy dissipation during rise time, in Joules, is:

$$E_{RISE} \geq V_{LOAD}^2 \cdot \frac{C_{RSS}}{I_{G\_SINK}} \cdot \frac{I_{LOAD}}{6} = \frac{P_{LOAD}}{6} \cdot t_{RISE}$$

The average power of the MOSFET for any load type in Watts is:

$$P_{AVG} = I_{LOAD}^2 \cdot R_{DSAT} \cdot D + f_{SWITCH} \cdot (E_{RISE} + E_{FALL})$$

Where  $f_{SWITCH}$  is the application switching frequency;  $R_{DSAT}$  is the MOSFET's on-resistance;  $D$  is the switch's operational duty cycle:  $D = t_{ON}/(t_{ON}+t_{OFF})$ ; and  $E_{FALL}$  is MOSFET energy dissipation during fall time, in Joules.

### 5.2 Inductive/Resistive Loads

If the load is resistive and inductive, and the inductance doesn't saturate, the load current during turn off,  $t_{RISE}$ , in Amps is:

$$I_{LOAD}(t) = \frac{V_{LOAD}}{R_{LOAD}} - \frac{I_{G\_SINK}}{L_{LOAD} \cdot C_{RSS}} \cdot \left( \frac{L_{LOAD}}{R_{LOAD}} \right)^2 \cdot \left[ \frac{R_{LOAD}}{L_{LOAD}} \cdot t - 1 + e^{-\frac{R_{LOAD}}{L_{LOAD}} \cdot t} \right]$$

and the MOSFET drain voltage during turn off,  $t_{RISE}$ , in Volts is:

$$V_{DRAIN}(t) = \frac{I_{G\_SINK}}{C_{RSS}} \cdot t$$

The instantaneous power in the MOSFET will be the product of the two equations and the energy will be the integral of the power over time.

### 5.3 Capacitive Loads

The energy absorbed by the MOSFET for loads that are more capacitive in nature occurs during the MOSFET turn-on as opposed to the turn-off. The energy absorbed by the MOSFET will be a function of the load, the TVS (or other protector), and the MOSFET drain capacitance. The MOSFET energy,  $E_{FALL}$ , in Joules is:

$$E_{FALL} = \frac{1}{2} \cdot (C_{TVS} + C_{OSS} + C_{LOAD}) \cdot V_{LOAD}^2$$

$C_{OSS}$  is the MOSFET output capacitance found in the data sheet. As mentioned earlier, the MOSFET switching losses occur at different times, either rising or falling, so loads with a combination of inductance and capacitance can also be calculated by the energy equations described above.

### 5.4 dV/dt Characteristics

The application circuit shown in **Figure 1** dissipates significant energy caused by large dV/dt events. Fault voltages across the MOSFET will turn it on for the same reason the part turns off slowly. For dV/dt events  $> I_{G\_SINK}/C_{RSS}$  (from Equation 2) the application circuit will dissipate energy proportional to the  $C_{RSS}$  and  $g_{FS}$  (forward conductance) of the selected transistor.  $C_{RSS}$  is a function of the transistor's on-resistance and current/power capability, so higher load designs are more sensitive.

The CPC1580 provides an internal clamp to protect the gate of the MOSFET from damage in such an event. The part can withstand 100mA for short periods, like dV/dt transients.

## 6. Design Switching Frequency

The maximum switching frequency is the last design value to be calculated, because the over-voltage protection and the storage capacitor play a significant role in determining the result. Inasmuch as those factors are already determined, the following gives a good approximation for the maximum switching frequency. The maximum switching frequency is a function of the gate charge of the MOSFET, the storage capacitor ( $C_{ST}$ ), and  $R_{OVP}$ . The maximum switching frequency relationship in Hz is:

$$F_{MAX} \leq \frac{1}{M} \cdot (t_{ON} + t_{OFF} + (t_{RISE,VD} \mid t_{CHG}) + t_{FALL,VD})^{-1}$$

Where:

- $M=3$  (multiplication factor for temperature and process variations)
- $t_{ON}$  and  $t_{OFF}$  are CPC1580 data sheet parameters
- $t_{RISE,VD}$  is the rise time of the drain voltage and  $t_{CHG}$  is the charge time of the storage capacitor and the over-voltage protection circuitry as derived in **Section 3.2**: choose the greater of  $t_{RISE,VD}$  or  $t_{CHG}$  for the calculation
- $t_{FALL,VD}$  is the fall time across the transistor

There is no minimum switching frequency since the CPC1580 uses photovoltaic diodes to keep the output charged while LED current flows.

## 7. Manufacturing Information

### 7.1 Soldering

For proper assembly, the component must be processed in accordance with the current revision of IPC/JEDEC standard J-STD-020. Failure to follow the recommended guidelines may cause permanent damage to the device resulting in impaired performance and/or a reduced lifetime expectancy.

### 7.2 Washing

Clare does not recommend ultrasonic cleaning or the use of chlorinated hydrocarbons.



### 7.3 Mechanical Dimensions

#### 8 Pin Flatpack Package

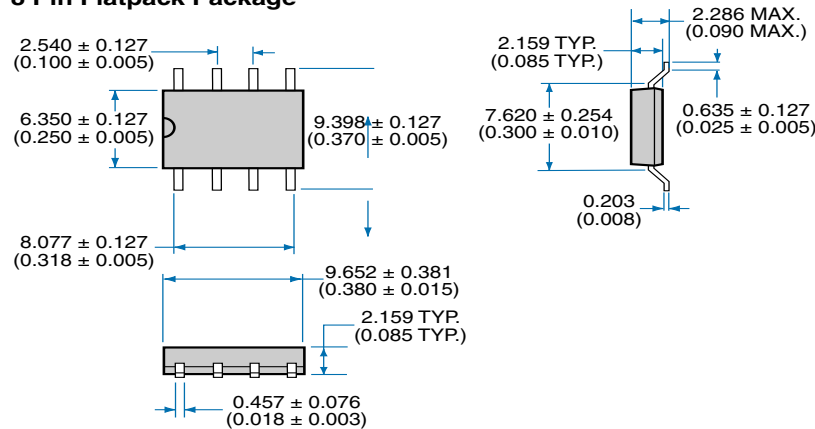

#### Recommended PCB Land Pattern

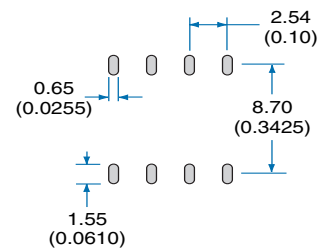

Dimensions  
mm  
(inches)

### 7.4 Tape and Reel Specification

#### Tape and Reel Packaging for 8 Pin Flatpack Package

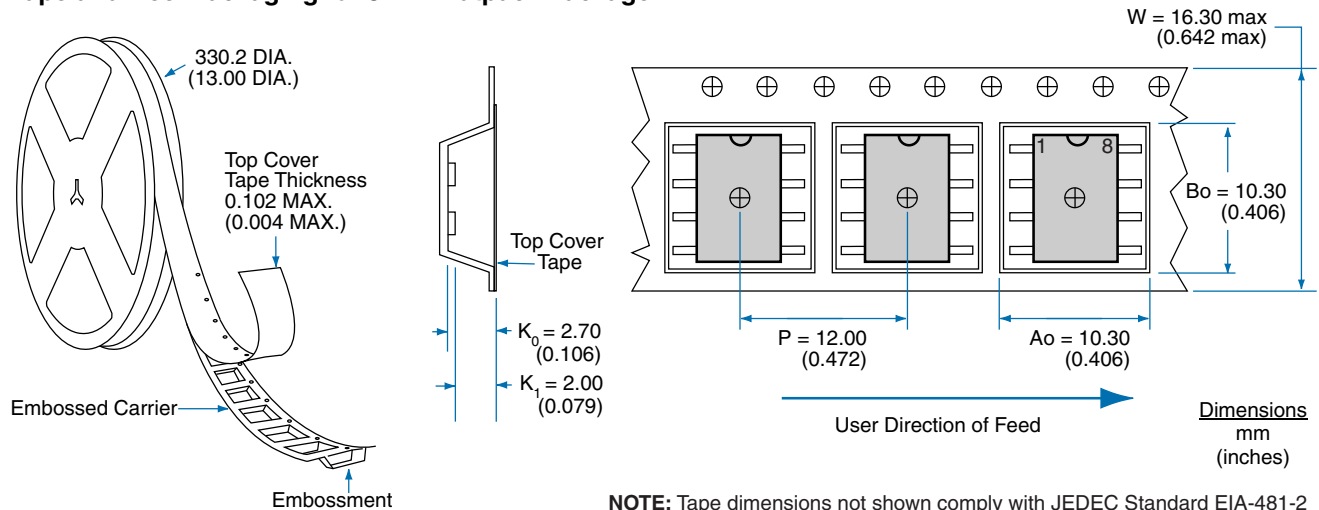

NOTE: Tape dimensions not shown comply with JEDEC Standard EIA-481-2

Dimensions  
mm  
(inches)

For additional information please visit our website at: [www.clare.com](http://www.clare.com)

Clare, Inc. makes no representations or warranties with respect to the accuracy or completeness of the contents of this publication and reserves the right to make changes to specifications and product descriptions at any time without notice. Neither circuit patent licenses nor indemnity are expressed or implied. Except as set forth in Clare's Standard Terms and Conditions of Sale, Clare, Inc. assumes no liability whatsoever, and disclaims any express or implied warranty, relating to its products including, but not limited to, the implied warranty of merchantability, fitness for a particular purpose, or infringement of any intellectual property right.

The products described in this document are not designed, intended, authorized or warranted for use as components in systems intended for surgical implant into the body, or in other applications intended to support or sustain life, or where malfunction of Clare's product may result in direct physical harm, injury, or death to a person or severe property or environmental damage. Clare, Inc. reserves the right to discontinue or make changes to its products at any time without notice.