

CRANE[®]

Energy Flow Solutions

CRANE Iron Valves



CRANE[®]

Index

General Data	5
Materials	6
Pressure/Temperature Ratings	7
C _v Coefficients	8
Gate Section	9
Globe Section	25
Check Section	30
Technical Data	39
Installation Recommendations	41

Crane also manufactures bronze ball valves, iron wafer and lug butterfly valves, and bronze gate, globe, and check valves. Brochures and catalogs are available on request.

Iron Valve Selection Guide & Figure Number Index

Catalog Page No.	CRANE Figure No.	Pressure Class	Stem: RS or NRS	Body/Trim IBBM, AI, 3Ni, 2NR	Bonnet/Cap: BB, TB, Clamp	End Connections	Disc
Iron Body Gate Valves - Descriptions and Features on Page 9							
10	460	125	NRS	IBBM	BB	THD	SW
11	461	125	NRS	IBBM	BB	FLG	SW
12	473	125	NRS	AI	BB	FLG	
13	464 ½	125	RS, OS&Y	IBBM	BB	THD	
14	465 ½	125	RS, OS&Y	IBBM	BB	FLG	
15	475 ½	125	RS, OS&Y	AI	BB	FLG	
16	488	125/150	RS	AI - Mall. Iron	Clamp	THD	
17	488 ½	125/150	RS	AI - Mall. Iron	Clamp	FLG	
18	490	125/150	RS	IBBM Mall. Iron	Clamp	THD	
19	484 ½	125	RS, OS&Y	AI - Mall. Iron	Clamp	THD	
20	485 ½	125	RS, OS&Y	AI - Mall. Iron	Clamp	FLG	
21	486 ½	125	RS, OS&Y	IBBM Mall. Iron	Clamp	THD	
22	487 ½	125	RS, OS&Y	IBBM Mall. Iron	Clamp	FLG	
23	3E	250	NRS	IBBM	BB	FLG	
24	7 ½ E	250	RS, OS&Y	IBBM	BB	FLG	
Iron Body Globe Valves - Descriptions and Features on Page 25							
26	351	125	RS, OS&Y	IBBM	BB	FLG	BRZ
27	21E	250	RS, OS&Y	IBBM	BB	FLG	BRZ
28	254XR	300	RS	AI - Mall. Iron	UB	THD	AI
Iron Body Angle Valves							
29	353	125	RS, OS&Y	IBBM	BB	FLG	BRZ
Iron Body Swing Check Valves - Descriptions and Features on Page 30							
31	372	125		IBBM	BC	THD	BRZ
32	373	125		IBBM	BC	FLG	BRZ
33	373 ½	125		AI	BC	FLG	Iron
34	383	125 w/outside lever & weight		IBBM	BC	FLG	BRZ
35	39E	250		IBBM	BC	FLG	BRZ
36	346 ½	300 Y-Pattern		AI - Mall. Iron	SC	THD	Iron
Iron Body Stop Check Valves							
37	28E	250 (straight flow)	RS, OS&Y	IBBM	BB	FLG	BRZ
38	30E	250 (90° angle flow)	RS, OS&Y	IBBM	BB	FLG	BRZ

NOTE: The following valves have been discontinued: 465, 467, 490½, 1670, 1671, 14477, 7E, 373RS, 375, 14493. Please consult factory* for possible substitutions.

* See back cover for Customer Service information.

BRONZE

GLOBE	Crane	NIBCO	Milwaukee
Class 125	1	T-211-B	502
Class 300 SS Trim	212P	T-276AP	593A

GATE

Class 125 RS-Thread	428	T-111	148
Class 125 NRS-Thread	438	T-113	105
Class 125 RS-Solder	1330	S-111	149
Class 125 NRS-Solder	1320	S-113	115
Class 150 Union Bonnet	431UB	T-134	1151
Class 300 SS Trim	634E	T-174-SS	1184

CHECK

Class 125 Thread	37	T-413-BY	509
Class 125 Solder	1340	S-413-B	1509
Class 300 Swing Check	76E	T-473-B	507
Class 300 Lift Check	366E	----	----

IRON

GATE	Crane	NIBCO	Milwaukee	Powell	Walworth
Class 125 NRS	461	F-619	F2882 A	1787	W719F
Class 125 OS&Y	465 ½	F-617-0	F2885 A	1793	W726F
Class 250 OS&Y	7 ½ E	F-667-0	F2894 A	1797	W786F

GLOBE

Class 125	351	F-718-B	F2981 A	241	W906F
-----------	-----	---------	---------	-----	-------

SWING CHECK

Class 125	373	F-918-B	F2974 A	559	W928F
-----------	-----	---------	---------	-----	-------

STOP CHECK

Class 250 Straight-way Y-Pattern	28E	----	----	----	----
Class 250 Angle Y-Pattern	30E	F-869-B	----	----	----

Advanced manufacturing techniques and equipment, ongoing engineering research and product development, skilled craftsman, and over 150 years of experience in flow control are behind the quality and dependability built into every Crane product.

Hydrostatic and Shock Working Pressures

Crane valves are suitable for liquid working pressures specified on catalog pages only when used in hydraulic installations in which shock is absent or negligible. The sudden closure of a valve in a hydraulic system causes the body of liquid, which may be moving at a rate generally in excess of one foot per second, to stop instantaneously. As liquids are relatively incompressible, the sudden cessation of flow effects a rise in pressure considerably greater than the static working pressure. This pressure increase is termed "SHOCK" and may, in some cases, be sufficient to cause valves or piping to fail.

Pressure increase due to shock is not dependent upon the working pressure in the system but upon the velocity at which the liquid is flowing. This pressure surge, or shock, severely limits design velocities...a fact readily understandable if it is remembered that pressure rise resulting from arrest of flow may be as high as 60 psi for each foot per second initial velocity. For example, installations of 100 psi and 1000 psi working pressures, with the same initial velocity of 10 feet per second, will be subject to the same increase in pressure (approximately 600 psi) due to instantaneous closure of a valve.

Shock generally prevails in lines equipped with check or quick-closing valves, or in lines supplied by reciprocating pumps. It may also be produced, to a lesser degree, by rapid closure of gate and globe valves. Therefore, care should be exercised when closing valves installed in liquid lines.

Where shock is likely to occur, the maximum shock pressure should be added to the working pressure of the line to determine working pressure of products in the line...also, hydraulic installations should be equipped with air chambers or other types of shock absorbers to eliminate, as much as possible, increase in pressure due to shock.

Testing

Iron valves described in this section meet or exceed the MSS SP-82, MSS SP-70, MSS SP-71 and MSS SP-85 specifications for testing.

Materials

The selection of materials for components of Crane valves is based upon expert metallurgical, engineering, foundry and fabrication knowledge as well as on many years of usage experience. Considerations affecting materials of parts which come in contact with the conveyed fluid include pressure, temperature and chemical composition of the fluid. The materials of moving parts that are subject to rubbing contact are selected on the basis of their resistance to wear, corrosion, seizing or galling, and on their frictional characteristics.

Utilization of materials to their full capability is assured by the use of stress analysis techniques that include extensive laboratory testing as well as the application of analytical theory. Stress levels for all materials used are maintained within the levels established by applicable codes, standards and specifications.

Metrication

This catalog shows equivalent metric values to the customary imperial units. The "soft" conversion was arrived at by following MSS SP-86 guidelines.

Illustrations , Weights and Material & Designs

Illustrations – Catalog illustrations are representative of a certain size of each line of product but do not necessarily represent all sizes in all details.

Material & Design – We reserve the right to institute changes in materials, designs, dimensions and specifications without notice in keeping with our policy of continuing product development.

Weights – shown are approximate and are not guaranteed. They represent the average weight of Crane Valves products as made from patterns in use at time weights were compiled.

Cast Iron

Used primarily for valve pressure retaining parts.
Recommended to 450 °F (232 °C).

ASTM A126, Class B

Chemical Requirements

	Minimum	Maximum
Sulphur %	–	0.15
Phosphorus %	–	0.75

Tensile Requirements

	Minimum	Maximum
Tensile Strength, psi	31,000	–
Transverse Test Load, lbs.	3,300	–
Deflection @ Center, in.	0.12	–

NI-Resist Iron

A copper-free alloy used where physical properties of cast iron suffice but where greater corrosion resistance is required. Castings are marked "2NR."

Ni-Resist is a registered trademark of the International Nickel Company, Inc.

ASTM A436, Type 2

Chemical Requirements

	Minimum	Maximum
Carbon %	–	3.00
Manganese %	0.50	1.50
Sulphur %	–	0.12
Silicon %	1.00	2.80
Chromium %	1.50	2.50
Nickel %	18.00	22.00
Copper %	–	0.50
Iron %		remainder

Tensile Requirements

	Minimum	Maximum
Tensile Strength, psi	25,000	–
Brinell Hardness (3000 Kg)	118	174

Malleable Iron

Used for valves subjected to expansion and contraction stresses and shock.

ASTM A338. Supplementary: ASTM A47, Grade 32510

Tensile Requirements

	Minimum	Maximum
Tensile Strength, psi	50,000	–
Yield Point, psi	32,500	–
elongation in 2 inches, %	10	–

Iron Valve Ratings

Introduction to Rating

The pressure-temperature ratings shown below apply to class 125 and 250 iron valves covered in this catalog.

A. Ratings for Class 125 and 250 iron valves are indicated on the relevant catalog page in this manner:

PSI Steam, Basic Rating: i.e.: is the nominal steam rated pressure of the valve.

Cold Working Pressure: where “Cold Working Pressure” is the maximum rated pressure of the valve at a temperature up to 150 °F (65 °C).

The full range of allowable pressure and temperature is determined by referring to the main pressure-temperature chart below.

B. Ratings for iron valves falling outside Class 125 and 250 are indicated in various ways on the relevant catalog page.

All ratings represent the maximum allowable non-shock pressure at the indicated temperature. If the operating temperature of your system is not shown, the allowable pressure may be interpolated.

The operating temperature of the valve is considered as the temperature of the media flowing through it. This temperature must not exceed the maximum allowable temperature as stated in the pressure-temperature chart below.

Pressure - Temperature Ratings

Crane Cast Iron Gate, Globe, Angle and Check Valves

U.S. Customary Units					
Class	125			250	
Temp. °F	Non-Shock-PSI				
	NPS 2"-12"	NPS 14"-24"	NPS 30"-48"	NPS 2"-12"	NPS 14"-24"
-20 to 150	200	150	150	500	300
200	190	135	115	460	280
225	180	130	100	440	270
250	175	125	85	415	260
275	170	120	65	395	250
300	165	110	50	375	240
325	155	105	–	355	230
350	150	100	–	335	220
375	145	–	–	315	210
400	140	–	–	290	200
425	130	–	–	270	–
450	125	–	–	250	–

Metric Units					
Class	125			250	
Temp. °C	Non-Shock-kPa				
	NPS 2"-12"	NPS 14"-24"	NPS 30"-48"	NPS 2"-12"	NPS 14"-24"
-29 to 66	1380	1030	1030	3480	2070
90	1310	930	790	3170	1930
110	1240	900	670	3030	1860
120	1210	860	570	2860	1790
140	1170	830	450	2720	1720
150	1140	760	340	2590	1650
160	1070	720	–	2450	1590
180	1030	690	–	2310	1520
190	1000	–	–	2170	1450
200	970	–	–	2000	1380
220	900	–	–	1860	–
230	860	–	–	1720	–

Manufacturers Standardization Society (MSS)
Standard Practice SP-70, SP-71, SP-85

Flow Coefficients

C_v COEFFICIENTS*
(For estimating purposes only)

Gate Valves	2"	2 ½"	3"	4"	5"	6"	8"	10"	12"	14"	16"
	327	480	742	1314	2129	3175	5691	8970	13351	16277	21562
Globe Valves											
	50	74	114	202	327	487	1376	–	–	–	–
Swing Check Valves											
	131	192	297	526	852	1270	2276	3588	5340	6511	8625

Gate Valves	18"	20"	24"	30"	36"
	28715	35760	52165	82563	119910
Globe Valves					
	–	–	–	–	–
Swing Check Valves					
	11486	14304	20866	–	–

*Fully open. C_v=GPM @ 1 PSI ΔP, 60°F Water

The above values for Swing Check Valves are correct only when the valve is fully open. This corresponds to a velocity of 6 ft./sec. for water flow.

Iron Gate Valve Features

Crane gate valves offer the ultimate in dependable service wherever minimum pressure drop is important. They serve as efficient stop valves with fluid flow in either direction.

The straight through design offers little resistance to flow and reduces pressure drop to a minimum. A disc actuated by a stem and handwheel that moves up and down at right angles to the path of flow, and seats against two seat faces to shut off flow.

Gate valves are best for services that require infrequent valve operation, and where disc is kept either fully opened or closed. They are not recommended for throttling. With the usual type of gate valve, close flow regulation is impossible. Velocity of flow against a partly opened disc may cause vibration and chattering and result in damage to the seating surfaces. Also, when throttled, the disc is subjected to severe wire-drawing erosive effects.

Each valve in this section is classified by its pressure rating. All valves, except clamp gate valves, designated as Class 125 and 250 comply with MSS SP-70 Industry Specifications.

Bronze-trimmed valves are recommended for steam, water, air and non-corrosive oil or gas. All have bronze screwed-in seat rings and the discs are solid bronze in sizes 3" (80 mm) and smaller. In larger sizes, bronze rings are rolled into cast iron discs.

All-iron valves have integral seats, some valves have screwed in seat rings (discs are cast iron) and nickel-plated steel stems. They are recommended for oil, gas, gasoline, or fluids that corrode bronze but not iron or steel.

Features

Face-to-Face Dimensions of flanged end valves comply with MSS SP-70, conform to ASME B16.10 in their pressure class.

Flanged End Valves adhere to ASME Specification B16.1 for their pressure class.

Body and Bonnet Components are cast with rigorous control to ASTM A126 Class B Specification for cast-iron. Malleable iron, Ni-resist and 3% nickel iron are also available.

Handwheels are furnished on all valves. Manual gear, hydraulic or motor operators and chainwheels can be supplied when specified.

Backseating - Rising stem valves are equipped with backseats. It is recommended that the backseat be used as a means for determining the full open valve position. For normal operation in the open position, the stem should be backed off so that the

backseat is not in contact. This permits the stem packing to assume its intended sealing function and not conceal unsatisfactory stem packing. In the event of stem packing leakage, the backseat can be used to stop stem leakage until circumstances permit a system shutdown and time for packing replacement. Stem packing replacement with the valve under pressure and back-seated represents a hazard and should not be undertaken. The hazard is magnified as fluid pressure or temperature increases or when the fluid is toxic.

Solid Wedge Gate Valve Discs - The strong, simple, single piece design with long disc guides is a proven performer for all service conditions, particularly suitable for conditions of severe turbulence and stem vibration. Seat and disc surfaces are accurately machined and tapered for shut-off without undue strain.

Threaded End Valves have precision cut threads in accordance with ASME B1.20.1.

Crane Iron Gate Valves have an identification tag which indicates the valve catalog number and other pertinent data. It provides easy and accurate field reference.

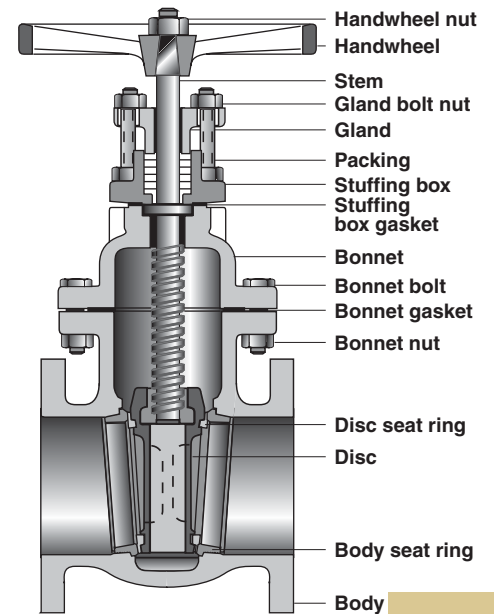
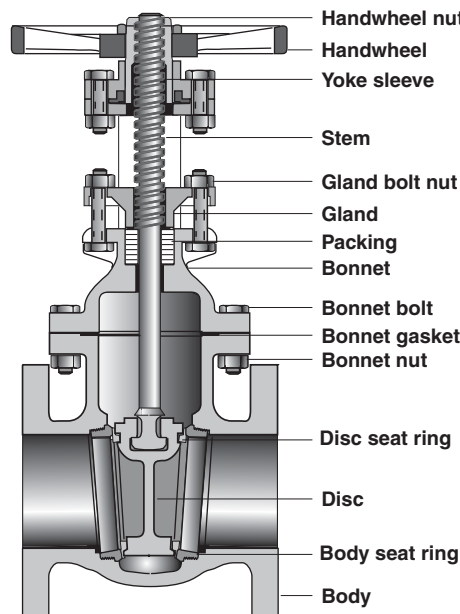
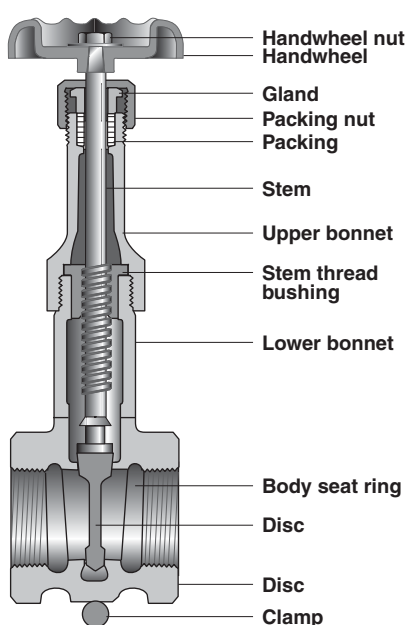

Class 125 • Bolted Bonnet • Non-Rising Stem • Bronze Trim • Threaded Ends

Figure 460

Threaded with Bronze Trim

Size Range:

2 through 4 inches

Working Pressures Non-Shock

125 psi Steam, Basic Rating

200 psi Cold Working Pressure

Features

- Tapered Solid Wedge Disc
- Body Guide Ribs
- Renewable Bronze Seat Rings
- Stem with ACME Double Threads
- Non-Asbestos Packing and Gaskets
- MSS SP-70 Type 1 and MSS SP-25
- ASME B1.20.1

For more detailed features, refer to Page 9.

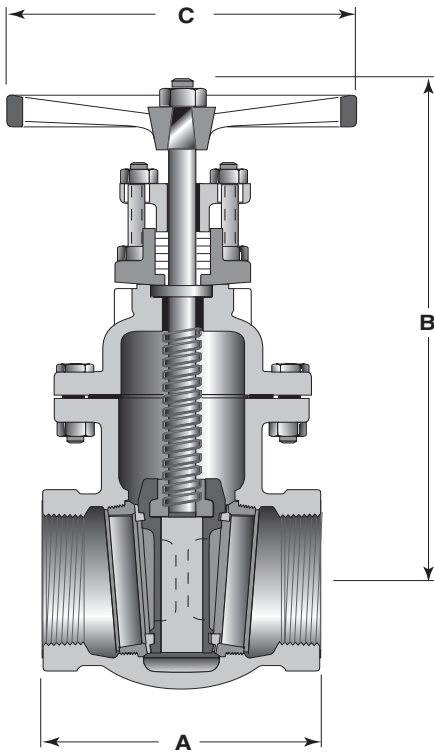

Principal Parts & Materials

Fig. No.	Size	Stem	Seating	End Conn.
460	2" - 4"	Bronze	Bronze	Threaded

Dimensions and Weights

Inches (millimeters) - pounds (kilograms)

Valves	2 (50)	2 ½ (65)	3 (80)	4 (100)
A	5.38 (137)	6.62 (168)	7.00 (178)	8.00 (203)
B	11.31 (287)	12.40 (315)	13.25 (337)	16.31 (414)
C	8.00 (203)	8.00 (203)	8.00 (203)	10.00 (254)
Wt.	25 (11)	31 (14)	44 (20)	71 (32)

Class 125 • Bolted Bonnet • Non-Rising Stem • Bronze Trim • Flanged Ends

Features

- Tapered Solid Wedge Disc
- Body Guide Ribs
- Renewable Bronze Seat Rings
- Stem provided with ACME Double Threads for valves 24" and smaller.
- Non-Asbestos Packing and Gaskets
- MSS SP-70 Type 1 and MSS SP-25
- ASME B16.10, ASME B16.1
- Valves can be equipped with by-passes when specified.

For more detailed features, refer to Page 9.

Figure 461

Flanged with Bronze Trim

Size Range:

2 through 30 inches

Working Pressures Non-Shock

2" – 12"

125 psi Steam, Basic Rating

200 psi Cold Working Pressure

14" – 30"

100 psi Steam, Basic Rating

150 psi Cold Working Pressure

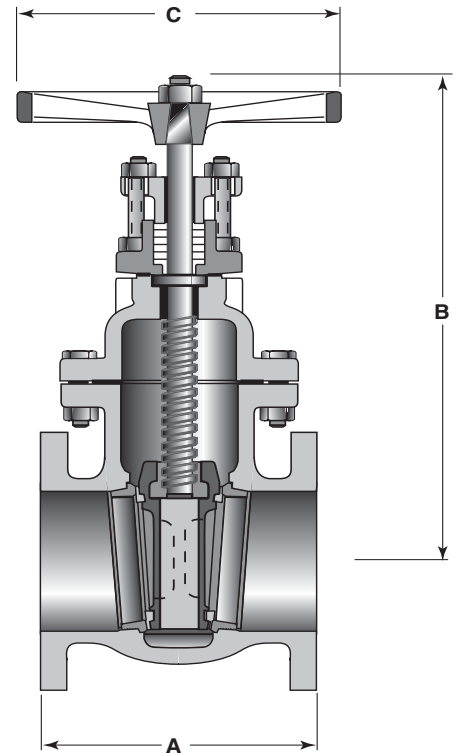

Principal Parts & Materials

Fig. No.	Size	Stem	Seating	End Conn.
461	2" - 30"	Bronze	Bronze	Flanged

Dimensions and Weights

Inches (millimeters) - pounds (kilograms)

Valves	2 (50)	2 ½ (65)	3 (80)	4 (100)	5 (125)	6 (150)	8 (200)	10 (250)	12 (300)	14 (350)	16 (400)	18 (450)	20 (500)	24 (600)	30 (750)
A	7.00 (178)	7.50 (191)	8.00 (203)	9.00 (229)	10.00 (254)	10.50 (267)	11.50 (292)	13.00 (330)	14.00 (356)	15.00 (381)	16.00 (406)	17.00 (432)	18.00 (457)	20.00 (508)	24.00 (610)
B	11.31 (287)	12.40 (315)	13.25 (337)	16.31 (414)	18.00 (457)	20.69 (526)	24.12 (613)	33.00 (838)	36.50 (927)	40.50 (1029)	48.00 (1219)	50.75 (1289)	56.12 (1425)	64.00 (1625)	86.63 (2200)
C	8.00 (203)	8.00 (203)	8.00 (203)	10.00 (254)	10.00 (254)	12.00 (305)	14.00 (356)	20.00 (508)	20.00 (508)	20.00 (508)	22.00 (559)	22.00 (559)	24.00 (610)	30.00 (762)	30.00 (762)
Wt.	30 (14)	40 (18)	56 (25)	90 (41)	126 (57)	152 (68)	260 (117)	490 (222)	672 (304)	968 (440)	1180 (535)	1701 (772)	2188 (993)	3150 (1432)	6009 (2728)

Class 125 • Bolted Bonnet • Non-Rising Stem • All Iron • Flanged Ends

Figure 473

Flanged – All Iron

Size Range:

2 through 8 inches

Working Pressures Non-Shock

200 psi Cold Working Pressure

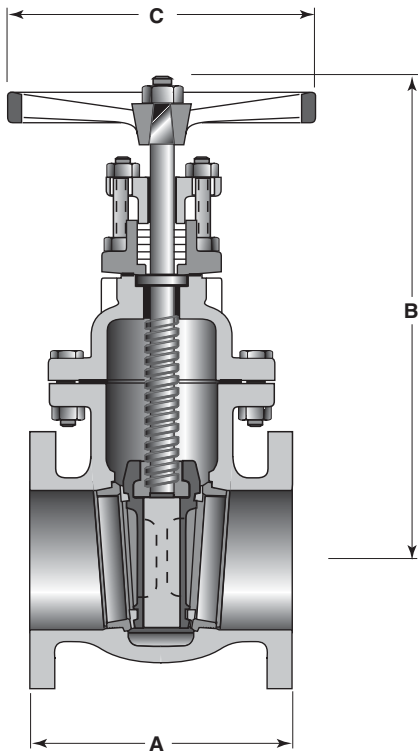

Features

- Tapered Solid Wedge Disc
- Body Guide Ribs
- Integral Seats
- Stem with ACME Double Threads
- Non-Asbestos Packing and Gaskets
- MSS SP-70 Type 1 and MSS SP-25
- ASME B16.10, ASME B16.1
- Valves can be equipped with by-passes when specified.

For more detailed features, refer to Page 9.

Principal Parts & Materials

Fig. No.	Size	Stem	Seating	End Conn.
473	2" - 8"	Steel Nickel plated	Iron	Flanged

Dimensions and Weights

Inches (millimeters) - pounds (kilograms)

Valves	2	2 ½	3	4	5	6	8
	(50)	(65)	(80)	(100)	(125)	(150)	(200)
A	7.00 (178)	7.50 (191)	8.00 (203)	9.00 (229)	10.00 (254)	10.50 (267)	11.50 (292)
B	11.31 (287)	12.40 (315)	13.25 (337)	16.31 (414)	18.00 (457)	20.69 (526)	24.12 (613)
C	8.00 (203)	8.00 (203)	8.00 (203)	10.00 (254)	10.00 (254)	12.00 (305)	14.00 (356)
Wt.	30 (14)	44 (20)	56 (25)	91 (41)	126 (57)	152 (69)	260 (118)

Class 125 • Bolted Bonnet • OS&Y • Bronze Trim • Threaded Ends

Features

- Tapered Solid Wedge Disc
- Body Guide Ribs
- Renewable Bronze Seat Rings
- Stem with ACME Double Threads
- Non-Asbestos Packing and Gaskets
- MSS SP-70 Type 1 and MSS SP-25
- ASME B1.20.1

For more detailed features, refer to Page 9.

Figure 464 1/2

Threaded with Bronze Trim

Size Range:

2 through 4 inches

Working Pressures Non-Shock

125 psi Steam, Basic Rating
200 psi Cold Working Pressure

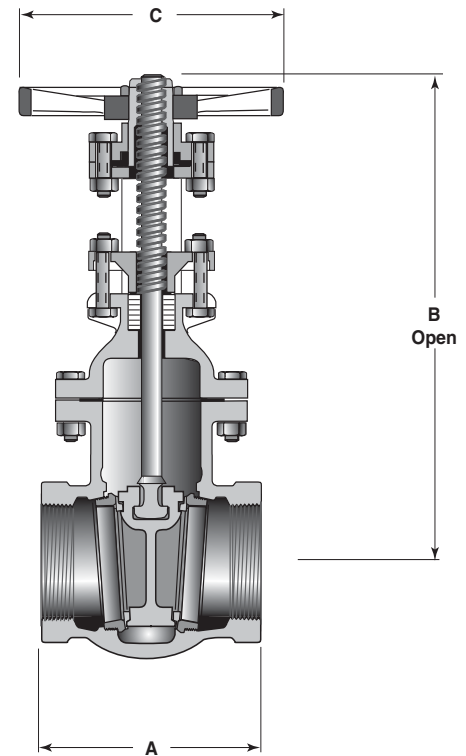

Principal Parts & Materials

Fig. No.	Size	Stem	Seating	End Conn.
464 1/2	2" - 4"	Bronze	Bronze	Threaded

Dimensions and Weights

Inches (millimeters) - pounds (kilograms)

Valves	2 (50)	2 1/2 (65)	3 (80)	4 (100)
A	5.38 (137)	6.62 (168)	7.00 (178)	8.00 (203)
B	14.75 (375)	16.06 (408)	17.38 (441)	21.44 (545)
C	8.00 (203)	8.00 (203)	8.00 (203)	10.00 (254)
Wt.	25 (11)	38 (17)	46 (21)	77 (35)

Class 125 • Bolted Bonnet • OS&Y • Bronze Trim • Flanged Ends

Figure 465 1/2
 Flanged with Bronze Trim
Size Range:
 2 through 36 inches

Working Pressures Non-Shock
 2" – 12"
 125 psi Steam, Basic Rating
 200 psi Cold Working Pressure
 14" – 36"
 100 psi Steam, Basic Rating
 150 psi Cold Working Pressure

Features

- Tapered Solid Wedge Disc
- Body Guide Ribs
- Renewable Bronze Seat Rings
- Stem provided with ACME Double Threads for 24" and smaller valves.
- Non-Asbestos Packing and Gaskets
- MSS SP-70 Type 1 and MSS SP-25
- ASME B16.10, ASME B16.1
- Valves can be equipped with by-passes when specified.

For more detailed features, refer to Page 9.

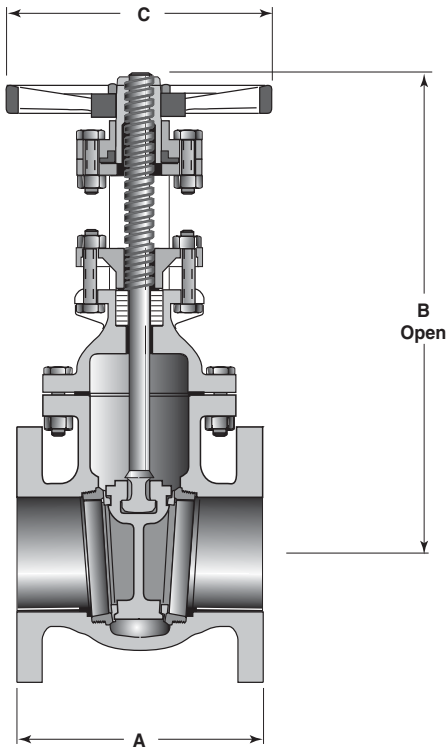

Principal Parts & Materials

Fig. No.	Size	Stem	Seating	End Conn.
465 1/2	2" - 36"	Bronze	Bronze	Flanged

Dimensions and Weights

Inches (millimeters) - pounds (kilograms)

Valves	2 (50)	2 1/2 (65)	3 (80)	4 (100)	5 (125)	6 (150)	8 (200)	10 (250)	12 (300)	14 (350)	16 (400)	18 (450)	20 (500)	24 (600)	30 (750)	36 (900)
A	7.00 (178)	7.50 (191)	8.00 (203)	9.00 (229)	10.00 (254)	10.50 (267)	11.50 (292)	13.00 (330)	14.00 (356)	15.00 (381)	16.00 (406)	17.00 (432)	18.00 (457)	20.00 (508)	24.00 (610)	28.00 (711)
B	14.75 (375)	16.06 (408)	17.38 (441)	21.44 (545)	25.81 (656)	30.31 (770)	37.75 (959)	49.41 (1255)	56.81 (1443)	64.88 (1648)	75.25 (1911)	82.00 (2083)	90.62 (2302)	105.38 (2677)	160.25 (4070)	192.69 (4894)
C	8.00 (203)	8.00 (203)	8.00 (203)	10.00 (254)	10.00 (254)	12.00 (305)	14.00 (356)	18.00 (457)	18.00 (457)	20.00 (508)	22.00 (559)	22.00 (559)	24.00 (610)	30.00 (762)	30.00 (762)	30.00 (762)
Wt.	33 (15)	47 (21)	58 (26)	97 (44)	135 (61)	162 (73)	280 (126)	502 (228)	670 (304)	1093 (497)	1425 (646)	1738 (789)	2085 (946)	3183 (1445)	5795 (2629)	7622 (3457)

Class 125 • Bolted Bonnet • OS&Y • All Iron • Flanged Ends

Features

- Tapered Solid Wedge Disc
- Body Guide Ribs
- 2"-8" Integral Seats, 10" and larger Renewable Cast Iron Seat Rings
- Stem provided with ACME Double Threads for 12" and smaller valves;
- Non-Asbestos Packing and Gaskets
- MSS SP-70 Type 1 and MSS SP-25
- ASME B16.10, ASME B16.1
- Valves can be equipped with by-passes when specified.

For more detailed features, refer to Page 9.

Figure 475 1/2

Flanged – All Iron

Size Range:

2 through 36 inches

Working Pressures Non-Shock

2" – 36"

200 psi Cold Working Pressure

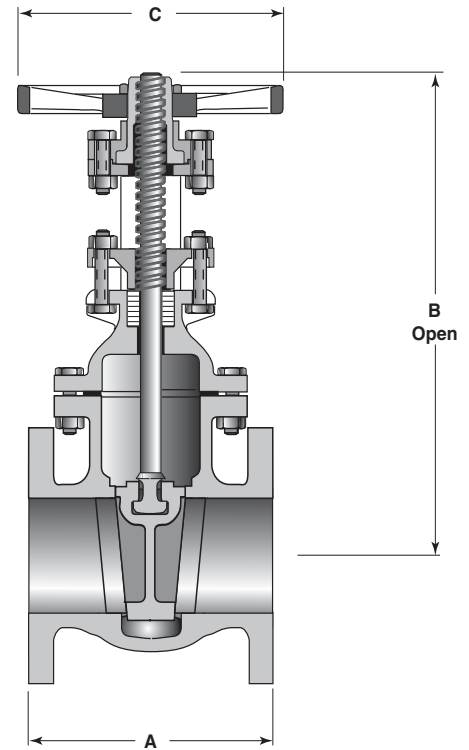

Principal Parts & Materials

Fig. No.	Size	Stem	Seating	End Conn.
475 1/2	2" - 36"	Steel Nickel Plated	Iron	Flanged

Dimensions and Weights

Inches (millimeters) - pounds (kilograms)

Valves	2 (50)	2 1/2 (65)	3 (80)	4 (100)	5 (125)	6 (150)	8 (200)	10 (250)	12 (300)	14 (350)	16 (400)	18 (450)	20 (500)	24 (600)	30 (750)	36 (900)
A	7.00 (178)	7.50 (191)	8.00 (203)	9.00 (229)	10.00 (254)	10.50 (267)	11.50 (292)	13.00 (330)	14.00 (356)	15.00 (381)	16.00 (406)	17.00 (432)	18.00 (457)	20.00 (508)	24.00 (610)	28.00 (711)
B	14.75 (375)	16.06 (408)	17.38 (441)	21.44 (545)	25.81 (656)	30.31 (770)	37.75 (959)	49.41 (1255)	56.81 (1443)	64.38 (1635)	75.25 (1911)	82.00 (2083)	90.62 (2302)	105.28 (2674)	129.62 (3292)	155.62 (3953)
C	8.00 (203)	8.00 (203)	8.00 (203)	10.00 (254)	10.00 (254)	12.00 (305)	14.00 (356)	18.00 (457)	18.00 (457)	20.00 (508)	22.00 (559)	22.00 (559)	24.00 (610)	30.00 (762)	36.00 (914)	42.00 (1067)
Wt.	33 (15)	47 (21)	58 (26)	97 (44)	135 (61)	162 (73)	280 (126)	502 (228)	670 (304)	1093 (497)	1738 (790)	1738 (790)	2085 (911)	3183 (1446)	5795 (2360)	7522 (3417)

Class 150 • U-Bolt Bonnet • Rising Stem • All Iron • Threaded Ends

Figure 488
Threaded - All Iron
Size Range:
¼ through 4 inches

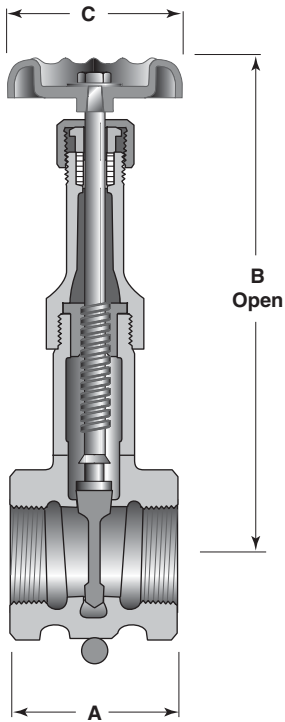

Features

- Compact Design
- Easy Maintenance
- Steel U-Bolt Clamp
- Anti-Clogging Bonnet
- Integral Seats
- Malleable Iron Disc
- Nickel Plated Steel Stem
- Non-Asbestos Packing & Gaskets
- Body and Bonnet Malleable Iron
- ASME B1.20.1
- Every valve is individually tested

For more detailed features, refer to Page 9.

TEMPERATURE		WORKING PRESSURES, NON-SHOCK			
Valve Ratings		¼" - 2" (6mm to 50mm)		2 ½" to 4" (65mm to 100mm)	
		225 psi, CWP		175 psi, CWP	
°F	°C	PSI	kPa	PSI	kPa
-20 to 150	-30 to 65	225	1550	175	1210
200	93	210	1450	165	1140
225	107	200	1380	160	1100
250	121	190	1310	150	1030
275	135	185	1280	145	1000
300	149	175	1210	140	970
325	163	165	1140	135	930
350	177	160	1100	125	860
375	191	150	1030	120	830

Principal Parts & Materials

Fig. No.	Size	Stem	Seating	End Conn.
488	¼" - 4"	Steel Nickel Plated	Iron	Threaded

Dimensions and Weights

Inches (millimeters) - pounds (kilograms)

Valves	¼ (6)	⅜ (10)	½ (15)	¾ (20)	1 (25)	1 ¼ (32)	1 ½ (40)	2 (50)	2 ½ (65)	3 (80)	4 (100)
A	3.00* (76)	3.00* (76)	2.06 (52)	2.32 (59)	2.56 (65)	2.87 (73)	3.15 (80)	3.62 (92)	4.13 (105)	4.57 (116)	5.55 (141)
B	5.08 (129)	5.08 (129)	5.08 (129)	6.18 (157)	7.40 (188)	8.90 (226)	9.96 (253)	11.61 (295)	12.91 (328)	15.35 (390)	19.76 (502)
C	2.06 (52)	2.06 (52)	2.06 (52)	2.56 (65)	2.75 (70)	3.06 (78)	3.62 (92)	4.06 (103)	4.76 (121)	5.98 (152)	9.00 (229)
Wt.	1.40 (0.64)	1.40 (0.64)	1.86 (0.84)	2.40 (1.09)	3.50 (1.59)	5.80 (2.63)	7.00 (3.17)	11.20 (5.08)	19.20 (8.71)	23.10 (10.47)	52.10 (23.61)

*Includes Hexagon Bushings in each end.

Class 125 • U-Bolt Bonnet • Rising Stem • All Iron • Flanged Ends

Features

- Compact Design
- Easy Maintenance
- Steel U-Bolt Clamp
- Anti-Clogging Bonnet
- Integral Seats
- Malleable Iron Disc
- Nickel Plated Steel Stem
- Non-Asbestos Packing & Gaskets
- Body and Bonnet Malleable Iron
- ASME B16.1
- Every valve is individually tested

For more detailed features, refer to Page 9.

Figure 488 1/2

Flanged - All Iron

Size Range:

1 through 4 inches

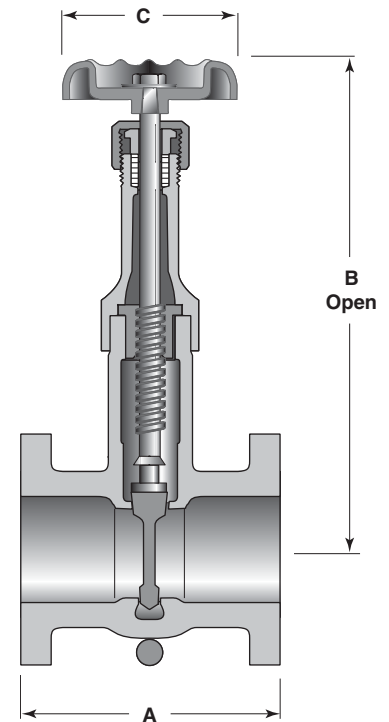

TEMPERATURE		WORKING PRESSURES, NON-SHOCK			
Valve Ratings		1" to 2" (25mm to 50mm)		2 1/2" to 4" (65mm to 100mm)	
		200 psi, CWP		175 psi, CWP	
°F	°C	PSI	kPa	PSI	kPa
-20 to 150	-30 to 65	200	1380	175	1210
200	93	185	1280	165	1140
225	107	175	1210	160	1100
250	121	165	1140	150	1030
275	135	155	1070	145	1000
300	149	145	1000	140	970
325	163	135	930	135	930
350	177	130	900	125	860
375	191	120	830	120	830

Principal Parts & Materials

Fig. No.	Size	Stem	Seating	End Conn.
488 1/2	1" - 4"	Steel Nickel Plated	Iron	Flanged

Dimensions and Weights

Inches (millimeters) - pounds (kilograms)

Valves	1 (25)	1 1/2 (40)	2 (50)	2 1/2 (65)	3 (80)	4 (100)
A	3.19 (81)	3.74 (95)	4.25 (108)	4.92 (125)	5.08 (129)	6.77 (172)
B	7.40 (188)	9.96 (253)	11.61 (295)	12.91 (328)	15.35 (390)	19.76 (502)
C	2.76 (70)	3.62 (92)	4.06 (103)	4.76 (121)	5.98 (152)	9.02 (229)
Wt.	5.50 (2.49)	10.40 (4.71)	14.30 (6.48)	22.00 (9.97)	32.0 (14.50)	60.0 (27.19)

Class 150 • U-Bolt Bonnet • Rising Stem • Bronze Trim • Threaded Ends

Figure 490
Threaded - Bronze Trim
Size Range:
¼ through 4 inches

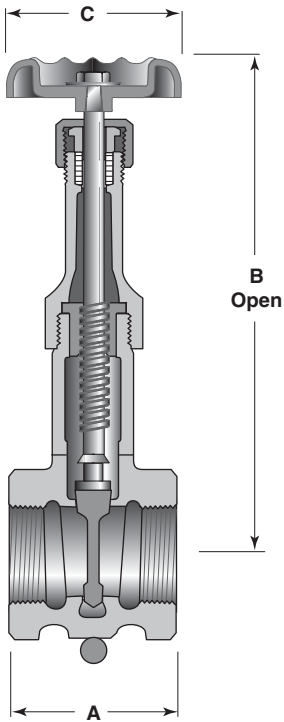

Features

- Compact Design
- Easy Maintenance
- Steel U-Bolt Clamp
- Anti-Clogging Bonnet
- Bronze Seat Rings
- Non-Asbestos Packing & Gaskets
- Body and Bonnet Malleable Iron
- ASME B1.20.1
- Bronze Disc
- Every valve is individually tested

For more detailed features, refer to Page 9.

TEMPERATURE		WORKING PRESSURES, NON-SHOCK			
Valve Ratings		¼" to 2" (6mm to 50mm)		2 ½" to 4" (65mm to 100mm)	
		150 psi, Sat. Steam 225 psi, CWP		125 psi, Sat. Steam 175 psi, CWP	
°F	°C	PSI	kPa	PSI	kPa
-20 to 150	-30 to 65	225	1550	175	1210
200	93	210	1450	165	1140
225	107	200	1380	160	1100
250	121	190	1310	150	1030
275	135	185	1280	145	1000
300	149	175	1210	140	970
325	163	165	1140	135	930
350	177	160	1100	125	860
375	191	150	1030	120	830

Principal Parts & Materials

Fig. No.	Size	Stem	Seating	End Conn.
490	¼" - 4"	Bronze	Bronze	Threaded

Dimensions and Weights

Inches (millimeters) - pounds (kilograms)

Valves	¼ (6)	⅜ (10)	½ (15)	¾ (20)	1 (25)	1 ¼ (32)	1 ½ (40)	2 (50)	2 ½ (65)	3 (80)	4 (100)
A	3.00* (76)	3.00* (76)	2.06 (52)	2.32 (59)	2.56 (65)	2.87 (73)	3.15 (80)	3.62 (92)	4.13 (105)	4.57 (116)	5.55 (141)
B	5.08 (129)	5.08 (129)	5.08 (129)	6.18 (157)	7.40 (188)	8.90 (226)	9.96 (253)	11.61 (295)	12.91 (328)	15.35 (390)	19.76 (502)
C	2.06 (52)	2.06 (52)	2.06 (52)	2.56 (65)	2.76 (70)	3.07 (78)	3.62 (92)	4.06 (103)	4.76 (121)	5.98 (152)	9.02 (229)
Wt.	1.40 (0.64)	1.40 (0.64)	1.86 (0.84)	2.40 (1.08)	3.50 (1.59)	5.80 (2.63)	7.00 (3.17)	11.20 (5.08)	19.20 (8.71)	23.10 (10.47)	52.10 (23.61)

*Includes Hexagon Bushings in each end.

Class 125 • U-Bolt Bonnet • OS&Y • All Iron • Threaded Ends

Features

- Compact Design
- Easy Maintenance
- Steel U-Bolt Clamp
- Integral Seats
- Malleable Iron Disc
- Nickel Plated Steel Stem
- Non-Asbestos Packing & Gasket
- Body and Bonnet Malleable Iron
- ASME B1.20.1
- Every valve is individually tested

For more detailed features, refer to Page 9.

Figure 484 1/2

Threaded - All Iron
Size Range:
 1/2 through 3 inches

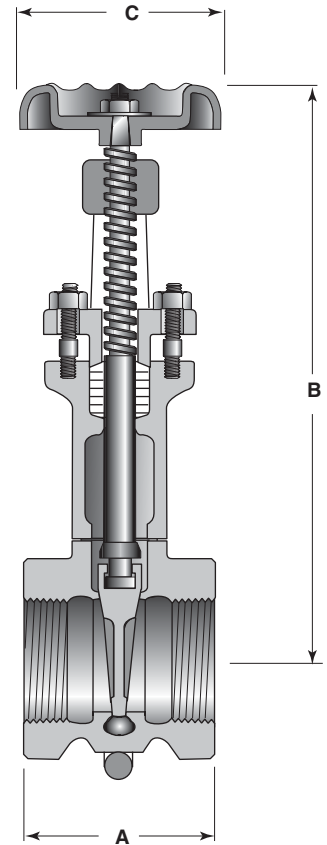

TEMPERATURE		WORKING PRESSURES, NON-SHOCK			
Valve Ratings		1/2" to 2" (12mm to 50mm)		2 1/2" to 3" (65mm to 75mm)	
		225 psi, CWP		175 psi, CWP	
°F	°C	PSI	kPa	PSI	kPa
-20 to 150	-30 to 65	225	1550	175	1210
200	93	210	1450	165	1140
225	107	200	1380	160	1100
250	121	190	1310	150	1030
275	135	185	1280	145	1000
300	149	175	1210	140	970
325	163	165	1140	135	930
350	177	160	1100	125	860
375	191	150	1030	120	830

Principal Parts & Materials

Fig. No.	Size	Stem	Seating	End Conn.
484 1/2	1/2" - 3"	Steel Nickel Plated	Iron	Threaded

Dimensions and Weights

Inches (millimeters) - pounds (kilograms)

Valves	1/2 (15)	3/4 (20)	1 (25)	1 1/4 (32)	1 1/2 (40)	2 (50)	2 1/2 (65)	3 (80)
A	2.06 (52)	2.32 (59)	2.56 (65)	2.87 (73)	3.15 (80)	3.62 (92)	4.12 (105)	4.56 (116)
B	6.75 (171)	7.52 (191)	9.25 (235)	10.25 (260)	12.24 (311)	14.50 (368)	16.50 (419)	19.00 (483)
C	2.56 (65)	2.56 (65)	2.75 (70)	3.06 (78)	3.62 (92)	4.06 (103)	4.75 (121)	6.00 (152)
Wt.	2.0 (0.91)	4.0 (1.81)	5.0 (2.26)	6.0 (2.72)	9.5 (4.31)	13.5 (6.12)	20.5 (9.30)	29.5 (13.38)

Class 125 • U-Bolt Bonnet • OS&Y • All Iron • Flanged Ends

Figure 485 1/2
 Flanged - All Iron
Size Range:
 1-1/2 through 4 inches

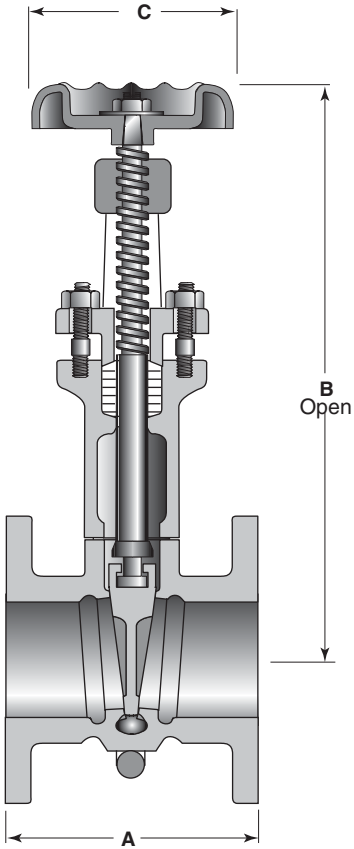

Features

- Compact Design
- Easy Maintenance
- Steel U-Bolt Clamp
- Integral Seats
- Malleable Iron Disc
- Nickel Plated Steel Stem
- Non-Asbestos Packing & Gasket
- Body and Bonnet Malleable Iron
- ASME B16.1
- Every valve is individually tested

For more detailed features, refer to Page 9.

TEMPERATURE		WORKING PRESSURES, NON-SHOCK			
Valve Ratings		1 1/2" to 2" (40mm to 50mm)		2 1/2" to 4" (65mm to 100mm)	
		200 psi, CWP		175 psi, CWP	
°F	°C	PSI	kPa	PSI	kPa
-20 to 150	-30 to 65	200	1380	175	1210
200	93	185	1280	165	1140
225	107	175	1210	160	1100
250	121	165	1140	150	1030
275	135	155	1070	145	1000
300	149	145	1000	140	970
325	163	135	930	135	930
350	177	130	900	125	860
375	191	120	830	120	830

Principal Parts & Materials

Fig. No.	Size	Stem	Seating	End Conn.
485 1/2	1-1/2" - 4"	Steel Nickel Plated	Iron	Flanged

Dimensions and Weights

Inches (millimeters) - pounds (kilograms)

Valves	1 1/2 (40)	2 (50)	2 1/2 (65)	3 (80)	4 (100)
A	3.74 (95)	4.25 (108)	4.94 (125)	5.06 (129)	6.75 (171)
B	12.24 (311)	14.50 (368)	16.50 (419)	19.00 (483)	24.00 (610)
C	3.62 (92)	4.06 (103)	4.75 (121)	6.00 (152)	9.00 (229)
Wt.	14.5 (6.58)	19.5 (8.84)	31.0 (14.06)	40.0 (18.14)	75.0 (34.01)

Class 125 • U-Bolt Bonnet • OS&Y • Bronze Trim • Threaded Ends

Features

- Compact Design
- Easy Maintenance
- Steel U-Bolt Clamp
- Bronze Seat Rings
- Bronze Disc
- Non-Asbestos Packing & Gasket
- Body and Bonnet Malleable Iron
- ASME B1.20.1
- Every valve is individually tested

For more detailed features, refer to Page 9.

Figure 486 1/2
 Threaded - Bronze Trim
Size Range:
 1/2 through 2 inches

TEMPERATURE		WORKING PRESSURES, NON-SHOCK	
Valve Ratings		1/2" to 2" (12mm to 50mm)	
		150 psi, Sat. Steam 225 psi, CWP	
°F	°C	PSI	kPa
-20 to 150	-30 to 65	225	1550
200	93	210	1450
225	107	200	1380
250	121	190	1310
275	135	185	1280
300	149	175	1210
325	163	165	1140
350	177	160	1100
375	191	150	1030

Principal Parts & Materials

Fig. No.	Size	Stem	Seating	End Conn.
486 1/2	1/2" - 2"	Bronze	Bronze	Threaded

Dimensions and Weights

Inches (millimeters) - pounds (kilograms)

Valves	1/2 (15)	3/4 (20)	1 (25)	1 1/2 (40)	2 (50)
A	2.06 (52)	2.32 (59)	2.56 (65)	3.15 (80)	3.62 (91)
B	6.75 (171)	7.52 (191)	9.25 (235)	12.24 (311)	14.50 (368)
C	2.56 (65)	2.56 (65)	2.75 (70)	3.62 (92)	4.06 (103)
Wt.	2.0 (0.91)	4.0 (1.81)	4.4 (2.00)	9.5 (4.31)	12.1 (5.49)

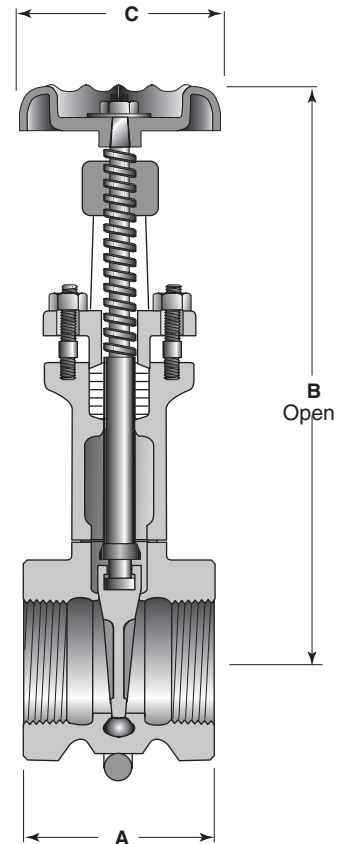

Class 125 • U-Bolt Bonnet • OS&Y • Bronze Trim • Flanged Ends

Figure 487 1/2
 Flanged - Bronze Trim
Size Range:
 1-1/2 through 4 inches

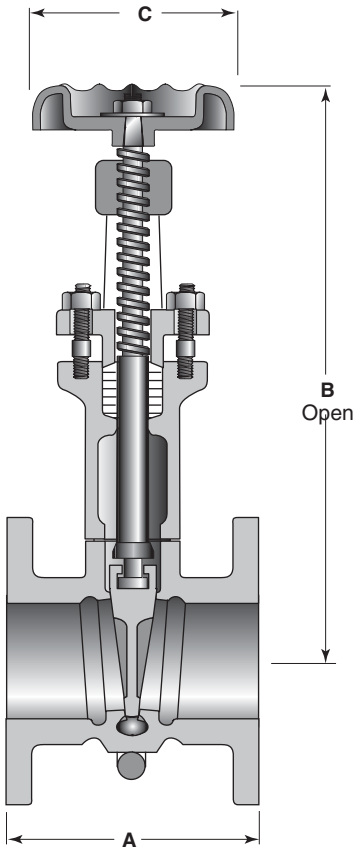

Features

- Compact Design
- Easy Maintenance
- Steel U-Bolt Clamp
- Bronze Seat Rings
- Bronze Disc
- Non-Asbestos Packing & Gasket
- Body and Bonnet Malleable Iron
- ASME B16.1
- Every valve is individually tested

For more detailed features, refer to Page 9.

TEMPERATURE		WORKING PRESSURES, NON-SHOCK			
Valve Ratings		1 1/2" to 2" (40mm to 50mm)		2 1/2" to 4" (65mm to 100mm)	
		125 psi, Sat. Steam 200 psi, CWP		125 psi, Sat. Steam 175 psi, CWP	
°F	°C	PSI	kPa	PSI	kPa
-20 to 150	-30 to 65	200	1380	175	1210
200	93	185	1280	165	1140
225	107	175	1210	160	1100
250	121	165	1140	150	1030
275	135	155	1070	145	1000
300	149	145	1000	140	970
325	163	135	930	135	930
350	177	130	900	125	860
375	191	120	830	120	830

Principal Parts & Materials

Fig. No.	Size	Stem	Seating	End Conn.
487 1/2	1-1/2" - 4"	Bronze	Bronze	Flanged

Dimensions and Weights

Inches (millimeters) - pounds (kilograms)

Valves	1 1/2 (40)	2 (50)	2 1/2 (65)	3 (80)	4 (100)
A	3.74 (95)	4.25 (108)	4.94 (125)	5.06 (129)	6.75 (171)
B	12.24 (311)	14.50 (368)	16.50 (419)	19.00 (485)	24.00 (510)
C	3.62 (92)	4.06 (103)	4.75 (121)	6.00 (152)	9.00 (229)
Wt.	13.0 (5.90)	17.0 (7.71)	31.0 (14.06)	40.0 (18.14)	75.0 (34.01)

Class 250 • Bolted Bonnet • Non-Rising Stem • Bronze Trim • Flanged Ends

Features

- Tapered Solid Wedge Disc
- Body Guide Ribs
- Renewable Bronze Seat Rings
- Non-Asbestos Packing & Gaskets
- Valves can be equipped with by-passes when specified
- Valves 6" and larger have bosses cast into the bodies and bonnets, and can be equipped with taps and drains to prevent fluids from accumulating and possibly causing damage. Orders must specify location of taps and drains.
- Stem with ACME Double Threads
- MSS SP-70 Type 1 and MSS SP-25 ASME B16.10, ASME B16.1

For more detailed features, refer to Page 9.

Figure 3E

Flanged with Bronze Trim

Size Range:
2 through 12 inches

Working Pressures Non-Shock
250 psi Steam, Basic Rating
500 psi Cold Working Pressure

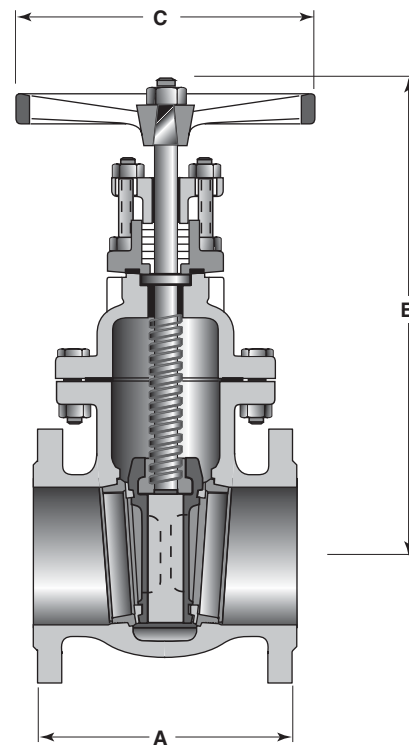

Principal Parts & Materials

Fig. No.	Size	Stem	Seating	End Conn.
3E	2" - 12"	Bronze	Bronze	Flanged

Dimensions and Weights

Inches (millimeters) - pounds (kilograms)

Valves	2 (50)	2 ½ (65)	3 (80)	4 (100)	6 (150)	8 (200)	10 (250)	12 (300)
A	8.50 (216)	9.50 (241)	11.12 (282)	12.00 (305)	15.88 (403)	16.50 (419)	18.00 (457)	19.75 (502)
B	11.94 (303)	12.94 (329)	14.50 (368)	17.38 (441)	23.00 (584)	30.75 (781)	36.00 (914)	39.75 (1010)
C	8.00 (203)	8.00 (203)	10.00 (254)	12.00 (305)	16.00 (406)	20.00 (508)	22.00 (559)	24.00 (610)
Wt.	47 (21)	84 (38)	113 (51)	175 (79)	335 (151)	545 (246)	854 (387)	1250 (567)

Class 250 • Bolted Bonnet • OS&Y • Bronze Trim • Flanged Ends

Figure 7 1/2E

Flanged with Bronze Trim

Size Range:

2 through 12 inches

Working Pressures Non-Shock

250 psi Steam, Basic Rating

500 psi Cold Working Pressure

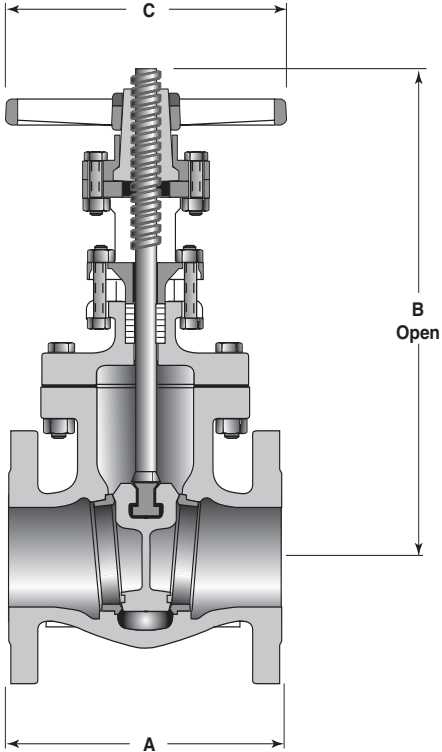

Features

- Tapered Solid Wedge Disc
- Body Guide Ribs
- Non Asbestos Packing and Gaskets
- Bronze Stem
- Renewable Bronze Seat Rings
- ACME Double Stem Threads
- Valves can be equipped with by-passes when specified.
- Valves 6" and larger have bosses cast into the bodies and bonnets, and can be equipped with taps and drains to prevent fluids from accumulating and possibly causing damage. Orders must specify location of taps and drains.
- MSS SP-70 Type 1 and MSS SP-25 ASME B16.10, ASME B16.1

For more detailed features, refer to Page 9.

Principal Parts & Materials

Fig. No.	Size	Stem	Seating	End Conn.
7 1/2E	2" - 12"	Bronze	Bronze	Flanged

Dimensions and Weights

Inches (millimeters) - pounds (kilograms)

Valves	2 (50)	2 1/2 (65)	3 (80)	4 (100)	5 (125)	6 (150)	8 (200)	10 (250)	12 (300)
A	8.50 (216)	9.50 (241)	11.12 (282)	12.00 (305)	15.00 (381)	15.88 (403)	16.50 (419)	18.00 (457)	19.75 (502)
B	15.06 (382)	16.69 (424)	18.75 (476)	23.44 (595)	24.00 (609)	31.75 (806)	39.88 (1012)	41.75 (1060)	47.00 (1193)
C	8.00 (203)	8.00 (203)	10.00 (254)	12.00 (305)	14.00 (356)	16.00 (406)	18.00 (457)	22.00 (559)	24.00 (610)
Wt.	54 (24)	80 (36)	114 (52)	174 (79)	280 (127)	332 (151)	600 (270)	920 (417)	1400 (635)

Iron Globe and Angle Valve Features

Crane globe and angle valves are highly efficient for throttling service because disc and seat designs provide flow characteristics with proportionate relationships between valve lift and flow rate. This assures accurate regulated flow control. The additional advantage of an angle valve is that it provides a 90° turn in piping so fewer joints are required and make-up time and labor are reduced.

Body and Bonnet are normally cast of Crane High Strength Cast conforming to ASTM A126, Class B. Malleable Iron valves are available for higher pressures.

Two types of bonnet construction are available:

Union Bonnet gives added strength and rigidity to the body to withstand internal pressure and distortion. Because it is easy to dismantle, it is used on smaller valves requiring frequent inspection or cleaning.

Bolted Bonnet is the most common design because there is practically no limitation on size. Multiple bolting permits equalized sealing pressure on the gasket against the highest pressures encountered in iron globe and angle valve applications. All bolted bonnet valves in this section comply with MSS SP-85 standard practice.

There are two types of discs supplied in Crane globe and angle valves:

Metal Disc in most valves is fully guided throughout its travel, minimizing vibration of internal parts and assuring true seating. The disc stem connection is designed to securely hold the disc yet permit swivel action. Disc materials are iron, bronze, iron faced with bronze, steel or a nickel alloy.

Metal Plug Disc is conically shaped. This design is universally accepted for rigorous service. Because of the wide seating surfaces, it is not easily harmed by foreign matter or wire drawing. Crane uses stainless steel in this design.

Seats are screwed in and can be reground or replaced whenever necessary.

Stem material is matched to service recommendations for improved operating dependability and life.

Packing non-asbestos rings.

Backseating: Rising stem valves are equipped with backseats. It is recommended that the backseat be used as a means for determining the full open valve position.

For normal operation in the open position, the stem should be backed off so that the backseat is not in contact. This permits the stem packing to assume its intended sealing function and not conceal unsatisfactory stem packing. In the event of stem packing leakage, the backseat can be used to stop stem leakage until circumstances permit a system shutdown and time for packing replacement. Stem packing replacement with the valve under pressure and backseated represents a hazard and should not be undertaken. The hazard is magnified as fluid pressure or temperature increases or when the fluid is toxic.

Handwheels are furnished on all valves. Manual gear, hydraulic or motor operators and chainwheels can be supplied when specified.

Face-to-Face Dimensions of flanged end valves conform to ASME B16.10 in their pressure class.

Flanged End Valves adhere to ASME specification B16.1 for their pressure class.

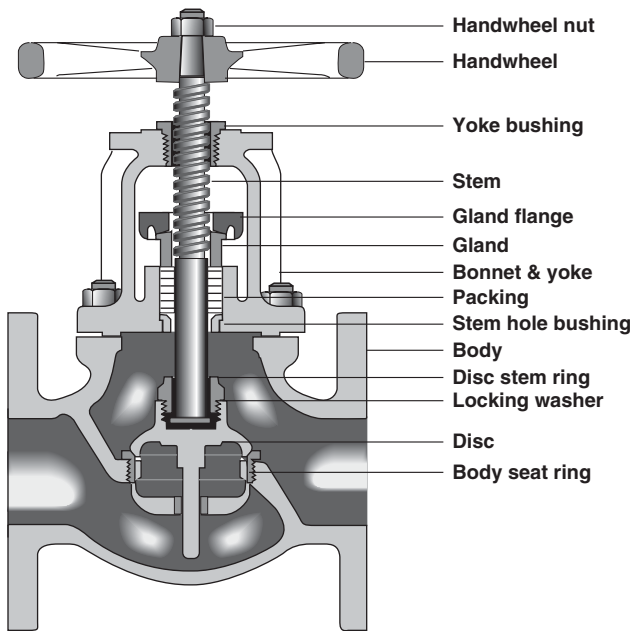

BOLTED BONNET, FLANGED

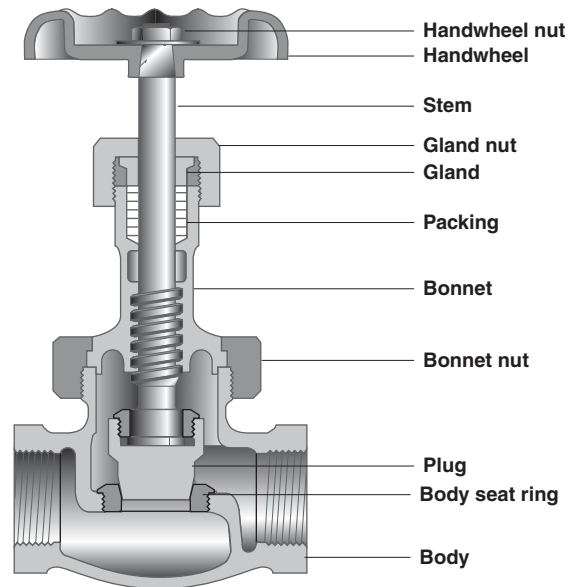

UNION BONNET, THREADED

Class 125 • Bolted Bonnet • OS&Y • Bronze Trim • Flanged Ends

Figure 351
Flanged with Bronze Trim
Size Range:
2 through 10 inches

Working Pressures Non-Shock
125 psi Steam, Basic Rating
200 psi Cold Working Pressure

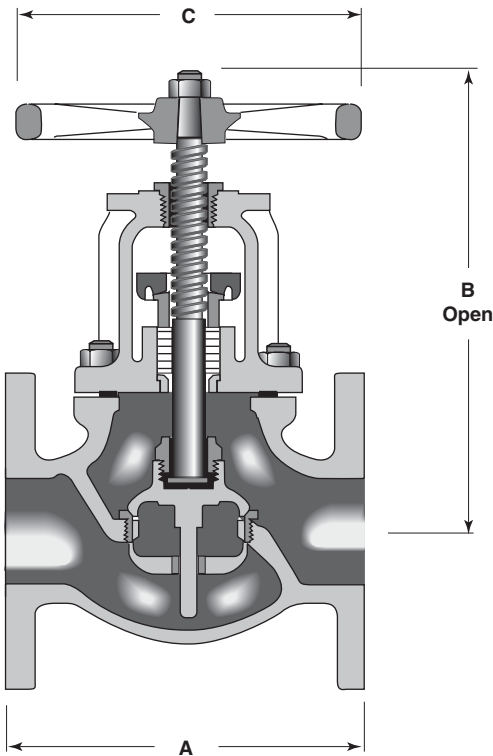

Features

- Integral Yoke Bonnet with upper and lower bronze bushing provides for centering of internal parts
- Non Galling Two-Piece Packing Gland
- Valves are provided with a Back Seat
- Renewable - Re grindable Screwed-in Seat Ring
- Bottom Guided Disc
- Manganese Bronze Stem
- Non-Asbestos Packing & Gasket
- Solid Bronze Disc 6" and smaller
- ASME B16.1, ASME B16.10
- MSS SP-85 Type 1 and MSS SP-25

For more detailed features, refer to Page 25.

Principal Parts & Materials

Fig. No.	Size	Stem	Seating	End Conn.
351	2" - 10"	Bronze	Bronze	Flanged

Dimensions and Weights

Inches (millimeters) - pounds (kilograms)

Valves	2 (50)	2 ½ (65)	3 (80)	4 (100)	5 (125)	6 (150)	8 (200)	10 (250)
A	8.00 (203)	8.50 (216)	9.50 (241)	11.50 (292)	13.00 (330)	14.00 (356)	19.50 (495)	24.50 (622)
B	11.12 (282)	11.50 (292)	13.25 (337)	15.50 (394)	17.50 (445)	19.50 (495)	25.00 (635)	30.50 (775)
C	8.00 (203)	8.00 (203)	9.00 (229)	10.00 (254)	10.00 (254)	12.00 (305)	16.00 (406)	18.00 (457)
Wt.	34 (15)	40 (18)	57 (26)	95 (43)	126 (57)	176 (80)	344 (156)	570 (259)

Class 250 • Bolted Bonnet • OS&Y • Bronze Trim • Flanged Ends

Features

- Integral Yoke Bonnet
- Non Galling Two-Piece Packing Gland
- Bronze Seat Ring, ASTM B61
- Disc Stem Ring
- Manganese Bronze Stem
- Non-Asbestos Packing and Gasket
- Valves are provided with a Back Seat
- Renewable - Re grindable, Screwed-in Seat Ring
- Bottom Guided Disc
- Solid Bronze Disc, ASTM B61 - 3" and smaller. 4" and larger cast iron with bronze facing, ASTM B61
- ASME B16.1, ASME B16.10
- MSS SP-85 Type 1 and MSS SP-25

For more detailed features, refer to Page 25.

Figure 21E

Flanged - Bronze Trim

Size Range:

2 through 8 inches

Working Pressures Non-Shock

250 psi Steam, Basic Rating

500 psi Cold Working Pressure

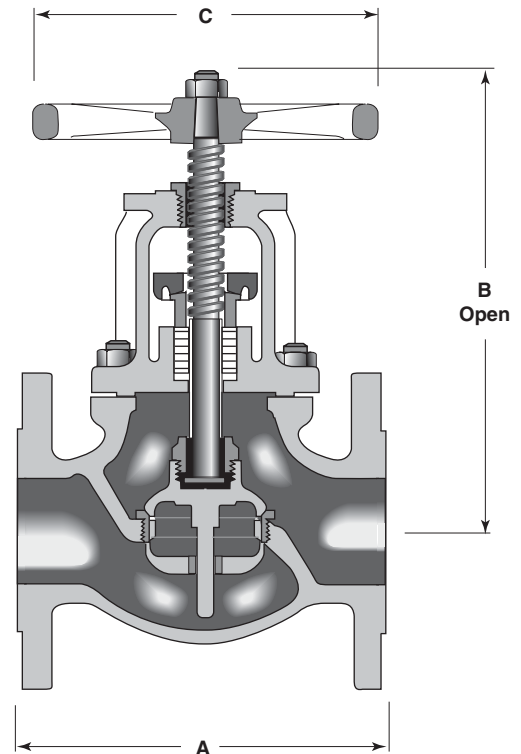

Principal Parts & Materials

Fig. No.	Size	Stem	Seating	End Conn.
21E	2" - 8"	Bronze	Bronze	Flanged

Dimensions and Weights

Inches (millimeters) - pounds (kilograms)

Valves	2 (50)	2 ½ (65)	3 (80)	4 (100)	6 (150)	8 (200)
A	10.50 (267)	11.50 (292)	12.50 (318)	14.00 (356)	17.50 (445)	21.00 (533)
B	13.75 (349)	14.75 (375)	16.50 (419)	18.50 (470)	23.25 (591)	28.50 (724)
C	9.00 (229)	10.00 (254)	10.00 (254)	12.00 (305)	16.00 (406)	20.00 (508)
Wt.	62 (28)	82 (37)	118 (54)	167 (76)	320 (145)	570 (259)

Class 300 • Union Bonnet • Rising Stem • Nickel Plug • Threaded Ends

Figure 254XR
 Threaded with 13% Chromium
 Nickel Alloy
Size Range:
 ¼ through 2 inches

Features

- Union Bonnet
- Valves are provided with a backseat
- Malleable Iron Body and Bonnet
- All sizes are air tested
- Disc - Nickel Alloy
- Seat Ring - 13% Chromium Stainless Steel
- Stem - 13% Chromium Stainless Steel
- ASME B1.20.1

For more detailed features, refer to Page 25.

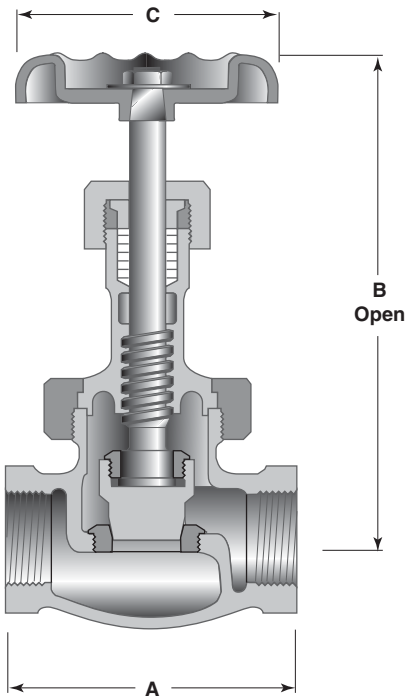

Temperature °F	Working Pressure Non-Shock, psi
-20 - 150°	1000
200	960
250	925
300	890
350	850
400	810
450	775
500	740
550	700

Principal Parts & Materials

Fig. No.	Size	Stem	Seating	End Conn.
254XR	¼" - 2"	13 CR. SS	Nickel Alloy	Threaded

Dimensions and Weights
 Inches (millimeters) - pounds (kilograms)

Valves	¼ 6	¾ 10	½ (15)	¾ (20)	1 (25)	1 ¼ (32)	1 ½ (40)	2 (65)
A	3.62 (92)	3.62 (92)	2.80 (71)	3.31 (84)	3.90 (99)	4.41 (112)	4.92 (125)	5.98 (152)
B	5.38 (137)	5.38 (137)	5.24 (133)	5.31 (135)	6.73 (171)	7.68 (195)	8.62 (219)	9.80 (249)
C	2.56 (65)	2.56 (65)	2.56 (65)	2.75 (70)	3.06 (78)	3.62 (92)	4.06 (103)	4.75 (121)
Wt.	1.8 (0.82)	1.8 (0.82)	1.7 (0.77)	2.5 (1.13)	3.8 (1.72)	5.9 (2.68)	8.0 (3.62)	12.7 (5.76)

Class 125 • Bolted Bonnet • OS&Y • Bronze Trim • Flanged End

Features

- Integral Yoke Bonnet with upper and lower bronze bushings provide for centering of internal parts
- Non Galling Two-Piece Packing Gland
- Valves are provided with a Back Seat
- Renewable - Regrindable Screwed-in Seat Ring
- Bottom Guided Disc
- Manganese Bronze Stem
- Non-Asbestos Packing & Gasket
- Solid Bronze Disc 6" and smaller
- ASME B16.1, ASME B16.10
- MSS SP-85 Type 2 and MSS SP-25

For more detailed features, refer to Page 25.

Figure 353

Flanged - Bronze Trim

Size Range:

2 through 6 inches

Working Pressures Non-Shock

125 psi Steam, Basic Rating

200 psi Cold Working Pressure

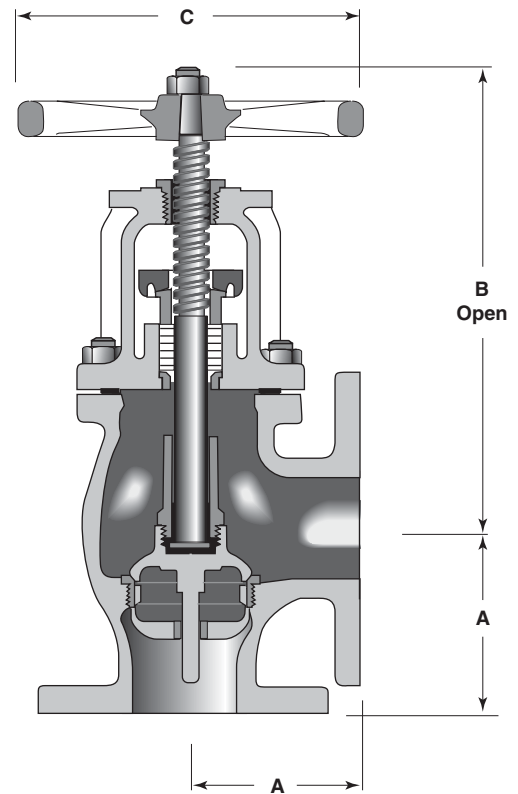

Principal Parts & Materials

Fig. No.	Size	Stem	Seating	End Conn.
353	2" - 6"	Bronze	Bronze	Flanged

Dimensions and Weights

Inches (millimeters) - pounds (kilograms)

Valves	2 (50)	2 ½ (65)	3 (80)	4 (100)	6 (150)
A	4.00 (102)	4.25 (108)	4.75 (121)	5.75 (146)	7.00 (178)
B	11.00 (279)	11.50 (292)	12.75 (324)	15.00 (381)	19.50 (495)
C	8.00 (203)	8.00 (203)	9.00 (229)	10.00 (254)	12.00 (305)
Wt.	32 (15)	38 (17)	54 (25)	88 (40)	158 (72)

Check valves permit flow in one direction only and close automatically when flow reverses. They are entirely automatic in action, depending upon differential pressure and velocity of flow within the line to perform their functions of opening and closing.

The disc and any associated moving parts may be in a constant state of movement if the velocity pressure is not sufficient to hold the disc in a wide open and stable position. Premature wear and noisy operation or vibration can be avoided by selecting the size of the check valve on the basis of flow conditions rather than selecting the check valve according to the size of the pipeline.

Sizing check valves on this basis may often result in the use of valves that are smaller than the pipe in which they are used, necessitating the use of reducers for installation. The pressure drop will be no greater than that of a larger valve that is partially open. Valve life will be greatly extended, and the added bonus, of course, is the lower cost of the smaller valves.

Each valve in this section is classified by its pressure rating.

All swing check valves designated as Class 125 and 250 comply with MSS SP-71 Standard Practice.

Tilting Disc Check Valves are similar in application to swing check valves. Essentially, the tilting disc check valve consists of a cylindrical housing with a pivoted circular disc. The pivots are located just above the center of the disc and offset from the plane of the body seat. This design decreases the travel distance of the disc, and the closing force due to reversal of flow and pressure differential is reduced by pivot location, thereby minimizing slam. The seat is of a circular bevel type and the disc pivots in or out of contact without rubbing or sliding, while full pressure differential acts to seal the disc tightly after seating.

Swing Check Valves with straight-through body design and wide hinge support provide turbulence-free flow and accurate seating. There is no tendency for seating surfaces to gall or score because the disc meets the flat seat squarely without rubbing. When faster reaction to flow reversal is necessary, certain valves can be equipped with an outside lever and weight. 2" - 12" with lever and weight come with adjustable lever. 14" - 24" valves must be specified for horizontal or vertical orientation.

This will assist the disc to close more rapidly and reduce the possibility of surge and shock.

Crane Iron Check Valves have an identification tag which indicates the valve catalog number and other pertinent data. It provides easy and accurate field reference.

Features

Threaded Ends in accordance with ASME B1.20.1.

Flanged Swing Check Valves conform to applicable requirements of ASME B16.10 in sizes 2" through 24". End flanges on valves conform to applicable requirements of B16.1 for classes 125 and 250.

Bronze Trim Valves are for steam, water, non-corrosive oil and gas and other fluids that do not corrode bronze.

All Iron Valves are for gases, oils and other fluids not corrosive to iron.

Valves May Be Installed in horizontal or vertical pipe lines. In vertical lines, or any angle from horizontal, they can be used for upward flow only.

Lever and Weight can be provided upon request to assist disc closure in unusual flow conditions. 2"-12" Figure 383 come standard with an adjustable lever arm which can be orientated in any position in 15° increments. These valves can be installed in horizontal lines, or in vertical lines with upward flow. 14"-24" valves must be specified at the time of inquiry and order with the installation orientation for horizontal or vertical-upward flow.

Non-Asbestos Gaskets and Packings.

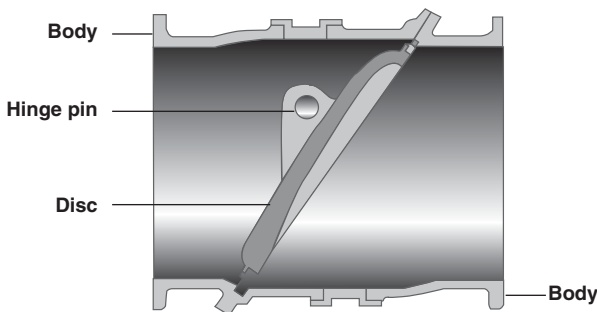

TILTING DISC

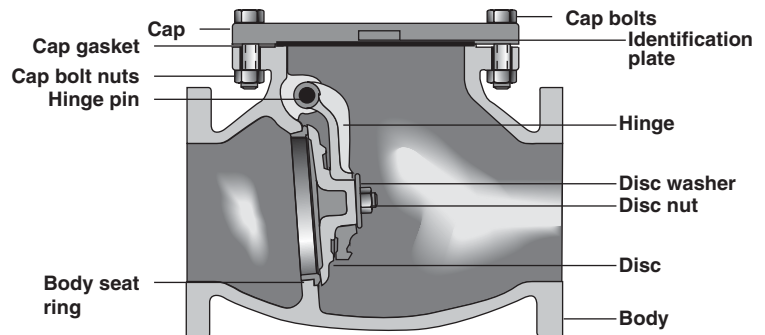

SWING CHECK

Class 125 • Bolted Cap • Bronze Trim • Threaded Ends

Features

- Design prohibits galling or scoring of seating surfaces because the disc meets the flat seat squarely on closing with no rubbing action
- Replaceable Bronze Seat Rings
- Bronze Hinges
- Solid Bronze Disc
- Large Bolted-on Cover
- Replaceable Brass Hinge Pin Bushings
- ASME B.1.20.1, MSS SP-71 Type 1 and MSS SP-25

For more detailed features, refer to Page 30.

Figure 372

Threaded with Bronze Trim

Size Range:

2 through 4 inches

Working Pressures Non-Shock

125 psi Steam, Basic Rating

200 psi Cold Working Pressure

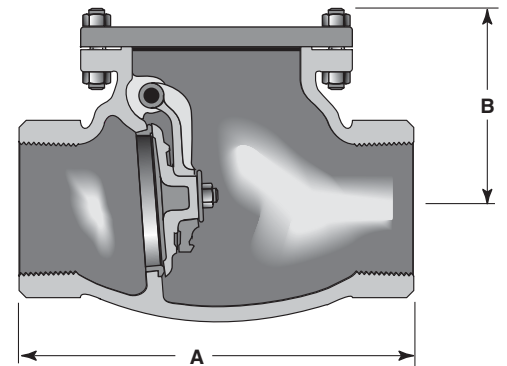

Principal Parts & Materials

Fig. No.	Size	Seating	End Conn.
372	2" - 4"	Bronze	Threaded

Dimensions and Weights

Inches (millimeters) - pounds (kilograms)

Valves	2 (50)	2 ½ (65)	3 (80)	4 (100)
A	6.12 (155)	7.25 (184)	8.00 (203)	9.25 (235)
B	4.50 (114)	5.38 (137)	5.88 (149)	6.62 (168)
Wt.	18 (8)	22 (10)	29 (13)	54 (25)

Class 125 • Bolted Cap • Bronze Trim • Flanged Ends

Figure 373

Flanged with Bronze Trim

Size Range:

2 through 24 inches

Working Pressures Non-Shock

2"-12"

125 psi Steam, Basic Rating

200 psi Cold Working Pressure

14"-24"

100 psi Steam, Basic Rating

150 psi Cold Working Pressure

Features

- Design prohibits galling or scoring of seating surfaces because the disc meets the flat seat squarely on closing with no rubbing action
- Replaceable Bronze Seat Rings
- Bronze Hinges in 6" and smaller, ductile iron in larger sizes
- Large Bolted-on Cover
- Solid Bronze Disc 6" and smaller, Bronze Faced Cast Iron on larger sizes
- Replaceable Brass Hinge Pins
- ASME B16.1, MSS SP-71 Type 1 and MSS SP-25
- ASME B16.10 - 14" and smaller

For more detailed features, refer to Page 30.

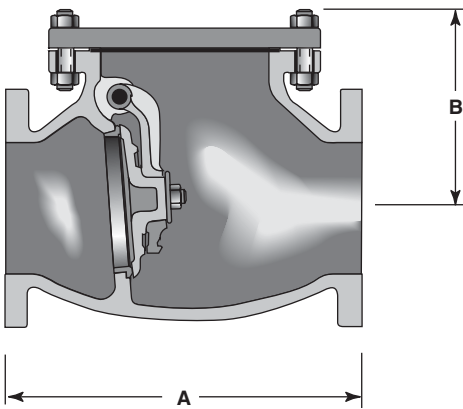

Principal Parts & Materials

Fig. No.	Size	Seating	End Conn.
373	2" - 24"	Bronze	Flanged

Dimensions and Weights

Inches (millimeters) - pounds (kilograms)

Valves	2 (50)	2 ½ (65)	3 (80)	4 (100)	5 (125)	6 (150)	8 (200)	10 (250)	12 (300)	14 (350)	16 (400)	18 (450)	20 (500)	24 (600)
A	8.00 (203)	8.50 (216)	9.50 (241)	11.50 (292)	13.00 (330)	14.00 (356)	19.50 (495)	24.50 (622)	27.50 (699)	31.00 (787)	36.00 (914)	36.00 (914)	40.00 (1067)	48.00 (1169)
B	4.50 (114)	5.38 (137)	5.88 (149)	6.62 (168)	7.75 (197)	8.25 (210)	10.25 (260)	12.00 (305)	13.75 (349)	15.75 (400)	17.25 (438)	19.00 (482)	21.87 (555)	24.43 (620)
Wt.	25 (11)	34 (15)	44 (20)	74 (33)	103 (47)	127 (58)	230 (104)	440 (200)	660 (299)	794 (360)	1020 (462)	1304 (591)	1771 (803)	2630 (1192)

Iron Body Swing Check Valve

Figure 373 1/2



Class 125 • Bolted Cap • All Iron • Flanged Ends

Features

- Design prohibits galling or scoring of seating surfaces because the disc meets the flat seat squarely on closing with no rubbing action
- Large Bolted On Cover
- Hinges are Ductile Iron
- Integral Body Seats 8" and smaller
- Replaceable 13% Chromium Stainless Steel Hinge Pins
- Replaceable Hinge Pin Bushings
- Disc is Solid Iron with Integral Seat Face
- ASME B16.1, ASME B16.10
- MSS SP-71 Type 1 and MSS SP-25

For more detailed features, refer to Page 30.

Figure 373 1/2

Flanged, All Iron Trim

Size Range:

2 through 24 inches

Working Pressure Non-Shock

200 psi Cold Working Pressure

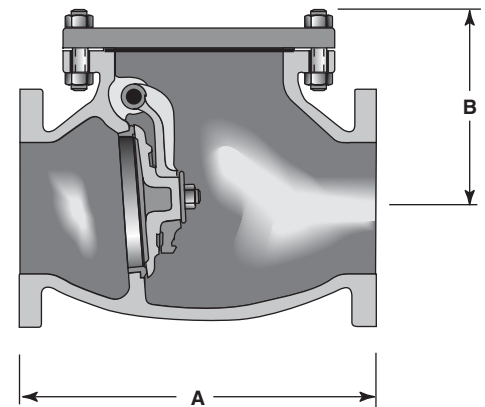

Principal Parts & Materials

Fig. No.	Size	Seating	End Conn.
373 1/2	2" - 24"	All iron	Flanged

Dimensions and Weights

Inches (millimeters) - pounds (kilograms)

Valves	2 (50)	2 1/2 (65)	3 (80)	4 (100)	5 (125)	6 (150)	8 (200)	10 (250)	12 (300)	14 (350)	16 (400)	18 (450)	20 (500)	24 (600)
A	8.00 (203)	8.50 (216)	9.50 (241)	11.50 (292)	13.00 (330)	14.00 (356)	19.50 (495)	24.50 (622)	27.50 (699)	31.00 (787)	36.00 (914)	38.00 (965)	42.00 (1067)	46.00 (1169)
B	4.50 (114)	5.38 (137)	5.88 (149)	6.62 (168)	7.75 (197)	8.25 (210)	10.25 (260)	13.06 (332)	15.25 (387)	15.75 (400)	17.00 (432)	17.40 (442)	19.50 (495)	20.50 (521)
Wt.	25 (11)	30 (13)	42 (19)	74 (33)	100 (45)	125 (56)	230 (104)	482 (218)	700 (318)	875 (397)	1410 (641)	1901 (864)	2530 (1149)	3366 (1529)

Class 125 • Bolted Cap • Bronze Trim • Flanged Ends • Lever & Weight

Figure 383

Flanged, outside lever and weight with bronze trim

Size Range:

2 through 24 inches

Working Pressure Non-Shock

2" - 12"

125 psi Steam, Basic Rating

200 psi Cold Working Pressure

14" - 24"

100 psi Steam, Basic Rating

150 psi Cold Working Pressure

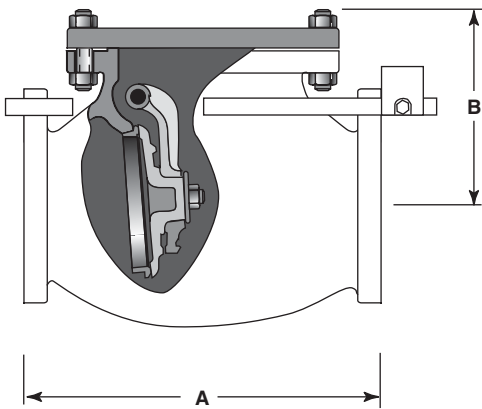

Features

- Design prohibits galling or scoring of seating surfaces because the disc meets the flat seat squarely on closing with no rubbing action
- Large Bolted On Cover
- Fig. 383 with outside lever and weight is recommended where quick action is necessary to avoid sudden reversal of flow. Weight can be installed to balance the disc when applications require that it open under minimum pressure. Positioning and setting of lever and weight are easily accomplished in the field. Lever can be rotated through 360° and is adjustable in 15° increments. As standard 2"-12" valves may be installed in horizontal pipe lines or vertical lines with upward flow. 14"-24" valves must be specified for specific installation orientation. Basic design of Fig. 383 identical to Fig. 373.
- Solid Bronze Disc 6" and smaller; Bronze Faced in 8" and larger.
- Replaceable Stainless Steel Hinge pins.
- Solid Bronze Hinge 6" and smaller; Ductile Iron for 8" and larger.

For more detailed features, refer to Page 30.

Principal Parts & Materials

Fig. No.	Size	Seating	End Conn.
383	2" - 24"	Bronze	Flanged

Dimensions and Weights

Inches (millimeters) - pounds (kilograms)

Valves	2 (50)	2 ½ (65)	3 (80)	4 (100)	6 (150)	8 (200)	10 (250)	12 (300)	14 (350)	16 (400)	18 (450)	20 (500)	24 (600)
A	8.00 (203)	8.50 (216)	9.50 (241)	11.50 (292)	14.00 (356)	19.50 (495)	24.50 (622)	27.50 (699)	31.00 (787)	36.00 (914)	36.00 (914)	40.00 (1067)	48.00 (1169)
B	4.50 (114)	5.38 (137)	5.88 (149)	6.62 (168)	8.25 (210)	10.25 (260)	12.00 (305)	13.75 (349)	16.00 (429)	18.00 (484)	19.25 (610)	22.25 (700)	24.88 (787)
Wt.	30 (14)	40 (18)	54 (24)	85 (38)	137 (62)	240 (108)	460 (208)	700 (317)	Data on larger sizes available on request				

Class 250 • Bolted Cap • Bronze Trim • Flanged Ends

Features

- For steam, water, oil, gas and similar high pressure-temperature conditions which do not warrant steel valves. Valves can be installed horizontally, or vertically for upward flow.
- High-Strength Cast Iron Body and Cap conforms to ASTM A126, Class B.
- Solid Bronze Disc in 3" and smaller; Bronze-faced Iron Disc in 4" and larger.
- Screwed-in Bronze Body Seat Ring
- Disc moves freely for maximum flow with minimum pressure drop. A disc stop, integral with the cap, prohibits the disc from sticking open when flow is reversed.
- ASME B16.1, ASME B16.10
- MSS SP-71 Type 1 and MSS SP-25

For more detailed features, refer to Page 30.

Figure 39E

Flanged - Bronze Trim

Size Range:

2 through 8 inches

Working Pressures Non-Shock

250 psi Steam, Basic Rating

500 psi Cold Working Pressure

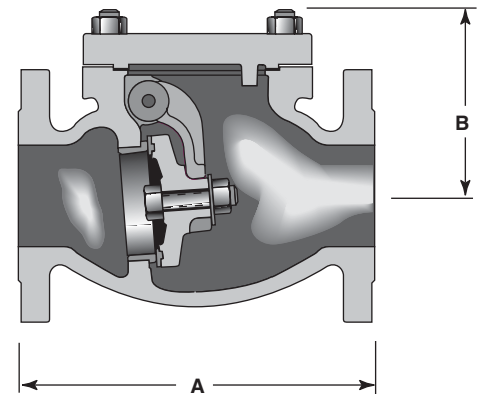

Principal Parts & Materials

Fig. No.	Size	Seating	End Conn.
39E	2" - 8"	Bronze	Flanged

Dimensions and Weights

Inches (millimeters) - pounds (kilograms)

Valves	2 (50)	2 ½ (65)	3 (80)	4 (100)	6 (150)	8 (200)
A	10.50 (267)	11.50 (292)	12.50 (318)	14.00 (356)	17.50 (445)	21.00 (533)
B	5.25 (133)	6.00 (152)	6.25 (159)	7.25 (184)	9.00 (229)	11.00 (279)
Wt.	46 (21)	64 (29)	90 (41)	133 (60)	250 (113)	410 (185)

Class 300 • Threaded Cap • Y-Pattern • All Iron • Threaded Ends

Figure 346 1/2
 Threaded - Malleable Iron
Size Range:
 1/2 through 2 inches

Features

- Malleable Iron Body and Cap
- Hinge Pin 13% Chromium Stainless Steel
- ASME B1.20.1

For more detailed features, refer to Page 30.

Temperature °F	Working Pressure Non-Shock, psi
-20 - 150°	1000
200	960
250	925
300	890
350	850
400	810
450	775
500	740
550	700

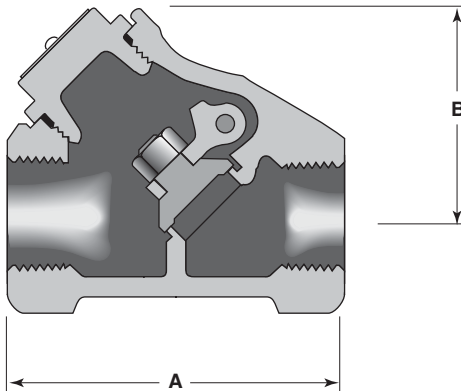

Principal Parts & Materials

Fig. No.	Size	Seating	End Conn.
346 1/2	1/2" - 2"	Iron	Threaded

Dimensions and Weights

Inches (millimeters) - pounds (kilograms)

Valves	1/2 (15)	3/4 (20)	1 (25)	1 1/4 (32)	1 1/2 (40)	2 (50)
A	2.75 (70)	3.27 (83)	4.06 (103)	4.75 (120)	5.40 (137)	6.62 (168)
B	1.68 (43)	2.00 (51)	2.45 (62)	2.85 (73)	3.29 (84)	4.28 (109)
Wt.	1.0 (0.43)	1.5 (0.65)	2.5 (1.11)	2.9 (1.30)	5.8 (2.61)	10.0 (4.51)

Class 250 • Bolted Bonnet • OS&Y • Bronze Trim • Flanged Ends

Features

- Valve designed for steam applications that operate between 100 and 250 psig.
- The Stop-Check feature of this valve requires a minimum of 50 psi pressure differential between piping system and boiler to operate properly.
- For installation between boilers supplying the same steam header, and positioned with pressure under the disc. Straightway is for horizontal or vertical line with upward flow. Angle valves are for "horizontal-downward" or "upward-horizontal" flow.
- These valves will perform the four following important functions:
 1. Act as an automatic-non return valve applied as a containment device to prevent gross backflow of steam from main header to boiler in case the boiler fails.
 2. Assist in cutting out boiler, when ceasing to fire. In this case, valve disc automatically closes to restrict backflow of steam to the boiler.
 3. Assist in returning boiler after a shut-down.
 4. Restricts backflow of steam from header into boiler which has been shut down and accidentally opened. The check valve feature should not be relied upon for primary shut-off.
- Cylindrical shaped disc is the only pressure-actuated part, light in weight with ample guiding surface. It is specially designed to produce a maximum lift at minimum velocities. There are no wing guides to cause "spinning" with resultant rapid wear.

Figure 28E

Flanged, Y-Pattern with Bolted Bonnet Straightway

Size Range:

2-½ through 10 inches

Working Pressures Non-Shock

250 psi Steam, Basic Rating

500 psi Cold Working Pressure

- Long throttling lip on disc retards flow when seating position is approached. Disc chattering is prevented and wire-drawing of seating surfaces is reduced.
- Flat Seats, accurately machined, facilitate true seating.
- Removable cast iron liner guides the disc throughout its full travel. Being entirely independent of the body, it is not subject to distortion by expansion strains.
- Piston Ring 6" and larger adds to dashpot's ability to avoid rapid disc movements. Where pulsations are extremely severe, two rings can be installed.
- Dashpot is self-contained in the liner. It provides an effective cushion for the disc to prevent pipe line vibrations or hammering on the seat at low velocities or on pulsating loads.
- Flanges conform to ASME B16.1. Flanges have 1/16" raised face with concentric grooves.
- The body has integral bosses for drain connections. The bosses are tapped and plugged.
- Determining the proper valve size needed is important. The size of a stop check valve should be based on the boiler capacity and steam flow through the valve, rather than on the size of the boiler outlet or existing piping.

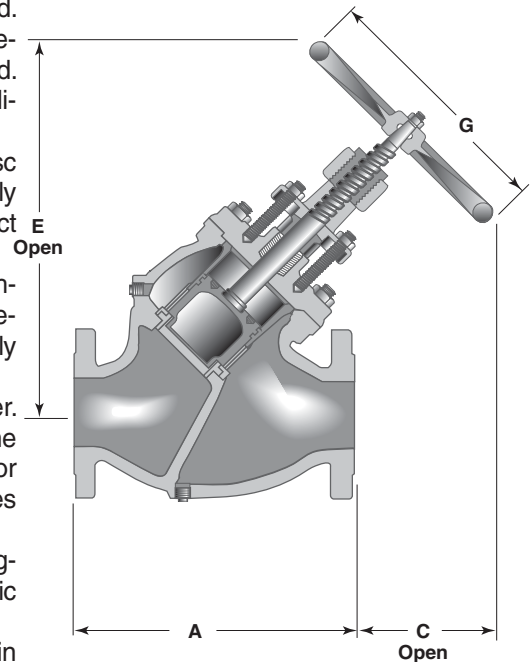

Dimensions and Weights

Inches (millimeters) - pounds (kilograms)

Valves	2 ½ (65)	3 (80)	4 (100)	5 (125)	6 (150)	8 (200)	10 (250)
A	13.00 (330)	14.75 (375)	17.00 (432)	19.00 (483)	21.50 (546)	26.00 (660)	30.00 (762)
C*	5.00 (127)	7.25 (184)	7.75 (197)	10.50 (267)	11.75 (298)	16.25 (413)	17.75 (451)
E*	15.75 (400)	19.75 (502)	21.75 (552)	25.75 (654)	29.25 (743)	36.75 (933)	41.75 (1060)
G	9.00 (229)	10.00 (254)	10.00 (254)	14.00 (356)	16.00 (406)	20.00 (508)	20.00 (508)
Wt.	103 (47)	140 (64)	226 (103)	307 (139)	420 (191)	737 (335)	1250 (568)

Class 250 • Bolted Bonnet • OS&Y • Bronze Trim • Flanged Ends

Figure 30E

Flanged, Y-Pattern with Bolted Bonnet Angle

Size Range:

2-½ through 10 inches

Working Pressures Non-Shock

250 psi Steam, Basic Rating

500 psi Cold Working Pressure

Features

- Valve designed for steam applications that operate between 100 and 250 psig.
- The Stop-Check feature of this valve requires a minimum of 50 psi pressure differential between piping system and boiler to operate properly.
- For installation between boilers supplying the same steam header, and positioned with pressure under the disc. Straightway is for horizontal or vertical line with upward flow. Angle valves are for "horizontal-downward" or "upward-horizontal" flow.
- These valves will perform the four following important functions:
 1. Act as an automatic-non return valve applied as a containment device to prevent gross backflow of steam from main header to boiler in case the boiler fails.
 2. Assist in cutting out boiler, when ceasing to fire. In this case, valve disc automatically closes to restrict backflow of steam to the boiler.
 3. Assist in returning boiler after a shut-down.
 4. Restricts backflow of steam from header into boiler which has been shut down and accidentally opened. The check valve feature should not be relied upon for primary shut-off.

- Cylindrical shaped disc is the only pressure-actuated part, light in weight with ample guiding surface. It is specially designed to produce a maximum lift at minimum velocities. There are no wing guides to cause "spinning" with resultant rapid wear.
- Long throttling lip on disc retards flow when seating position is approached. Disc chattering is prevented and wiredrawing of seating surfaces is reduced.
- Flat Seats, accurately machined, facilitate true seating.
- Removable cast iron liner guides the disc throughout its full travel. Being entirely independent of the body, it is not subject to distortion by expansion strains.
- Piston Ring 6" and larger adds to dashpot's ability to avoid rapid disc movements. Where pulsations are extremely severe, two rings can be installed.
- Dashpot is self-contained in the liner. It provides an effective cushion for the disc to prevent pipe line vibrations or hammering on the seat at low velocities or on pulsating loads.
- Flanges conform to ASME B16.1. Flanges have 1/16" raised face with concentric grooves.
- The body has integral bosses for drain connections. The bosses are tapped and plugged.
- Determining the proper valve size needed is important. The size of a stop check valve should be based on the boiler capacity and steam flow through the valve, rather than on the size of the boiler outlet or existing piping.

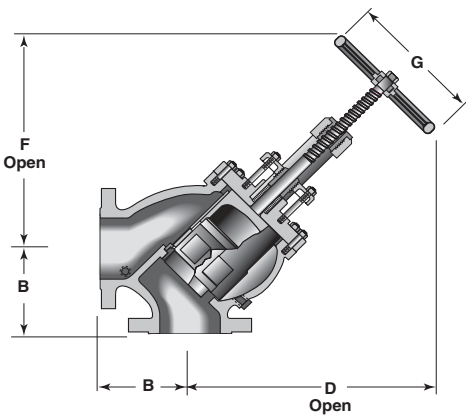

Dimensions and Weights

Inches (millimeters) - pounds (kilograms)

Valves	2 ½ (65)	3 (80)	4 (100)	5 (125)	6 (150)	8 (200)	10 (250)
B	5.75 (146)	6.25 (159)	7.00 (178)	7.88 (200)	8.75 (222)	10.50 (267)	12.25 (311)
D	14.50 (368)	16.50 (419)	18.50 (470)	22.00 (559)	25.50 (648)	33.25 (845)	37.75 (959)
F	13.25 (337)	14.75 (375)	16.25 (413)	19.50 (495)	22.50 (572)	28.75 (730)	32.50 (826)
G	9.00 (229)	10.00 (254)	10.00 (254)	14.00 (356)	16.00 (406)	20.00 (508)	20.00 (508)
Wt.	86 (39)	123 (56)	186 (84)	250 (113)	340 (154)	640 (291)	1025 (465)

Bolted Bonnet Stop Check Valve

Technical Data • Y-Pattern Stop Check Valve

Selecting the Proper Size – Determining Pressure Drop

Since stop-check valves have a floating disc member, it is important the valve be sized to provide full disc lift under flow conditions prevailing during the major portion of the service life. If the valve is too large, the disc will float in a partially open position and may cause fluttering of the disc and rapid wear. Conversely, if the valve is too small, pressure drop will be excessive.

The chart on the following page is a graphic presentation of flow data determined by test. Its use offers a simple method of determining the best size stop-check valve, as well as the pressure drop under varying conditions of flow, without any computation.

How to Use the Chart Shown on the Following Page

Given: Steam Pressure-Temperature...250 psig 450°F
Flow Rate...Typical Daily Demand Curve

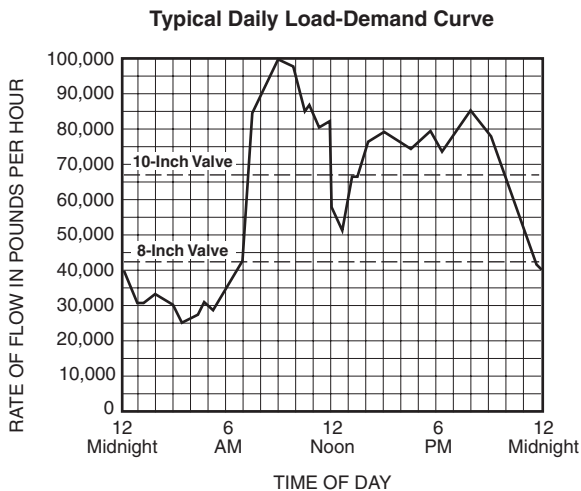

Find: Valve Catalog No. and the best size for above installation.

Solution:

1. Enter the Temperature chart at 450°F. Move vertically upward to the curved line for 250 psi, then horizontally to the right to establish a point on the specific volume scale. From this point, draw a line through the flow rate being investigated (100,000 Lb/H) and establish a point on Index 1.

2. From that point, draw another line through the valve size, for example the 8-inch size, and establish a point on Index 2. Now move horizontally to the diagonal pressure drop line on the right side. Where these lines intersect, the pressure drop is 7.5 psi for the 8-inch, Class 250 globe valve and 8.5 psi for the 8-inch Class 250 angle valve.

Chart solutions resulting in a point on Index 2 that falls below the Line A-A for Class 250 valves indicate the disc will not be fully lifted under the flow conditions used. Operation under such conditions is not recommended but, at times, must be tolerated for short periods during the low loads.

3. Enter the chart where Line A-A intersects Index 2 for Class 250 valves. Move diagonally upward through the size being investigated (8-inch) and establish a second point on Index 1. From this point, extend a line to the specific volume established in Step 1 and at its intersection with the flow rate line, read 48,000 Lb/H as the minimum flow rate at which the disc will be in the fully lifted position. The pressure drop at this flow rate is 1.9 psi for globe and 2.1 psi for angle valves.

4. Repeat Steps 2 and 3 for other possible valve sizes, tabulate results, and make size selection on basis of pressure drop and duration of partial disc lift considerations.

Valve Size (Inches)	Press drop @ Max.Min. Flow rate (100,000 #/Hr.), psi		Flow Rate for Wide open valve #/Hr.
	Globe	Angle	
6	20.5	22.5	26,500
8	7.5	8.5	48,000
10	3.3	3.6	68,000

Dotted lines on Demand Curve indicate minimum flow rates for wide open 8" and 10" valves.

5. The best choice for this example would be the 10" size because pressure drop is much lower and duration of partially lifted disc is only slightly greater than for the 8" size.
6. Pressure drop for any intermediate flow condition can be determined as outlined in Steps 1 and 2.

Installation Recommendations

Y-Pattern Stop-Check and Isolation Gate Valves

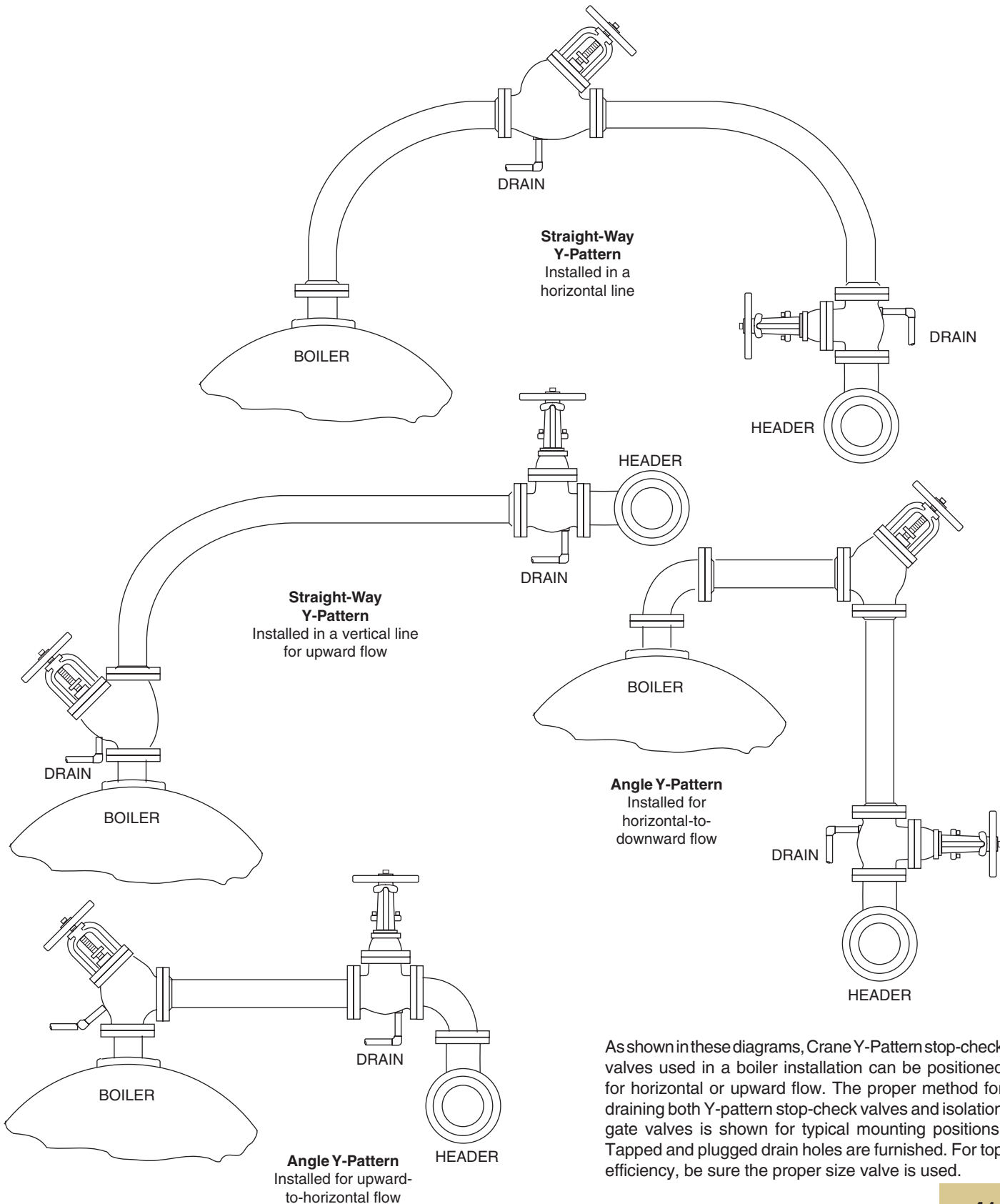

Notes

CRANE[®]

Energy Flow Solutions

CRANE[®]

CRANE Energy Global Headquarters

19241 David Memorial Drive, Suite 150
Shenandoah, Texas 77385
Tel: +1-936-271-6500
Fax: +1-936-271-6510

CRANE Customer Service

2129 3rd Avenue S.E.
Cullman, Alabama 35055
Tel: +1-256-775-3800
Fax: +1-256-775-3860

Conroe Operations

9860 Johnson Road
Montgomery, Texas 77316
Tel: +1-936-588-8380
Fax: +1-936-588-8381

www.craneenergy.com

CRANE Energy Flow Solutions[™]

brands you know...technology you want...solutions you need



Ball, Check, Corrosion Resistant Gate and Globe Valves



Ball, Bronze, Butterfly, Cast Steel, and Iron Valves



Lined Check and Resilient Seated Butterfly Valves

NOZ-CHEK[®] **COMPAC-NOZ[®]**

Nozzle-Type, Severe Service Check Valves

CRANE[®]

Ball, Bronze, Butterfly, Cast Steel, and Iron Valves



High Pressure and Severe Service Valves

DUO-CHEK[®] **UNI-CHEK[®]**

High Performance Wafer Check Valves

STOCKHAM[®]

Ball, Bronze, Butterfly, Cast Steel, and Iron Valves



High Performance and Metal Seated Butterfly Valves

VALVE SERVICES

Certified Valve Repair Services

Aloyco, Center Line, Compac-Noz, Crane, Duo-Chek, Flowseal, Jenkins, Noz-Chek,
Pacific, Stockham, and Uni-Chek are all trademarks of Crane Co. ©2008

EN-CR-CT-EN-L11-01-0810