



## Credit Risk Management

Basic Concepts: financial risk components,  
rating analysis, models, economic and regulatory capital

*This page intentionally left blank*

# Credit Risk Management

Basic Concepts: financial risk components,  
rating analysis, models, economic and regulatory capital

---

**Dr. Ir. TONY VAN GESTEL**

*Dexia Group, Risk Management Holding*

**Prof. Dr. BART BAESENS**

*Faculty of Business and Economics,*

*Katholieke Universiteit Leuven, Belgium*

*School of Management, University of Southampton, United Kingdom*

*Vlerick Leuven Ghent Management School, Belgium*

**OXFORD**  
UNIVERSITY PRESS

# OXFORD

UNIVERSITY PRESS

Great Clarendon Street, Oxford OX2 6DP

Oxford University Press is a department of the University of Oxford.

It furthers the University's objective of excellence in research, scholarship,  
and education by publishing worldwide in

Oxford New York

Auckland Cape Town Dar es Salaam Hong Kong Karachi  
Kuala Lumpur Madrid Melbourne Mexico City Nairobi  
New Delhi Shanghai Taipei Toronto

With offices in

Argentina Austria Brazil Chile Czech Republic France Greece  
Guatemala Hungary Italy Japan Poland Portugal Singapore  
South Korea Switzerland Thailand Turkey Ukraine Vietnam

Oxford is a registered trade mark of Oxford University Press  
in the UK and in certain other countries

Published in the United States  
by Oxford University Press Inc., New York

© Bart Baesens and Tony Van Gestel 2009

The moral rights of the authors have been asserted  
Database right Oxford University Press (maker)

First published 2009

All rights reserved. No part of this publication may be reproduced,  
stored in a retrieval system, or transmitted, in any form or by any means,  
without the prior permission in writing of Oxford University Press,  
or as expressly permitted by law, or under terms agreed with the appropriate  
reprographics rights organization. Enquiries concerning reproduction  
outside the scope of the above should be sent to the Rights Department,  
Oxford University Press, at the address above

You must not circulate this book in any other binding or cover  
and you must impose the same condition on any acquirer

British Library Cataloguing in Publication Data

Data available

Library of Congress Cataloging in Publication Data

Data available

Typeset by Newgen Imaging Systems (P) Ltd, Chennai, India

Printed in Great Britain

on acid-free paper by

CPI Antony Rowe, Chippenham, Wiltshire

ISBN 978-0-19-954511-7

10 9 8 7 6 5 4 3 2 1

# Preface

---

Credit risk management is undoubtedly among the most crucial issues in the field of financial risk management. With the recent financial turmoil and the regulatory changes introduced by Basel II, credit risk analysis and risk assessment in general have been receiving even greater attention by the financial and banking industry.

The ability to discriminate good customers from bad ones is a highly decisive element to be a successful player in the banking and credit industry. Predicting and mitigating default events is at the core of appropriate credit risk management and this can be greatly helped by employing suitable quantitative models, without however precluding the reliance on human expert judgment.

The optimal allocation of capital is also directly linked to appropriate credit risk models and has driven the interest of both academic and industrial communities. The recently established Basel II Capital Accord is an illustration of how modern credit risk management techniques can be transformed in capital adequacy for banks.

With their book, Tony Van Gestel and Bart Baesens provide newcomers to the field of risk management with a careful introduction to the different concepts of credit risk management, without entering into the technicalities often associated with this subject. This book is therefore appropriate for readers looking for a comprehensive and rigorous, yet accessible, description of the various concepts underlying credit risk management techniques used in modern banking.

Philippe Maystadt,  
president of the European Investment Bank  
August 2008

*This page intentionally left blank*

# Contents

---

<i>Acknowledgements</i>	ix
<i>Introduction</i>	xi
<i>Chapter by chapter overview</i>	xiii
<b>1. Bank risk management</b>	<b>1</b>
1.1 Introduction	1
1.2 Banking history	2
1.3 Role of banks	9
1.4 Balance sheet	17
1.5 Sources of risk	23
1.6 Risk management	38
1.7 Regulation	52
1.8 Financial products	59
<b>2. Credit scoring</b>	<b>93</b>
2.1 Introduction	93
2.2 Scoring at different customer stages	95
2.3 Score types	105
2.4 Credit bureaus	109
2.5 Overrides	111
2.6 Business objectives	112
2.7 Limitations	113
<b>3. Credit ratings</b>	<b>115</b>
3.1 Introduction	115
3.2 Rating and scoring systems	117
3.3 Rating terminology	118
3.4 A taxonomy of credit ratings	121
3.5 Rating system architecture	143



## viii Contents

3.6	Rating philosophy	145
3.7	External rating agencies	148
3.8	Rating system at banks	157
3.9	Application and use of ratings	162
3.10	Limitations	165
<b>4.</b>	<b>Risk modelling and measurement</b>	<b>168</b>
4.1	Introduction	168
4.2	System life cycle	170
4.3	Overview of rating systems and models	174
4.4	Data definition and collection	201
4.5	Development	251
4.6	Implementation	264
4.7	Application and follow-up	265
4.8	Validation, quality control and backtesting	266
<b>5.</b>	<b>Portfolio models for credit risk</b>	<b>273</b>
5.1	Introduction	273
5.2	Loss distribution	274
5.3	Measures of portfolio risk	278
5.4	Concentration and correlation	285
5.5	Portfolio model formulations	292
5.6	Overview of industry models	306
5.7	Basel II portfolio model	312
5.8	Implementation and application	325
5.9	Economic capital and capital allocation	327
<b>6.</b>	<b>Basel II</b>	<b>344</b>
6.1	Introduction	344
6.2	Bank capital	350
6.3	Pillar 1 (minimum capital requirements)	354
6.4	Pillar 2 (supervisory review process)	418
6.5	Pillar 3 (market discipline)	431
6.6	Information technology aspects	441
6.7	Market impact	452
6.8	Future evolution	479
	<i>References</i>	483
	<i>Index</i>	519

# Acknowledgements

---

It is a great pleasure to acknowledge the contributions and assistance of many individuals to the writing of this book. This book is the result of many years of academic research and industry experience, throughout which we have been involved in various social networks that all contributed to this writing in some way.

First of all, we would like to thank our editor, Oxford University Press. We are grateful to Alison Jones for contacting us three years ago with the idea of writing a book, which in fact turned out to be a book series. We would like to acknowledge the direct and indirect contributions of the many colleagues and friends with whom we collaborated during the last ten years. Olivier Creignou, Marc Itterbeek, Christian Latouche, Geert Kindt, Daniel Saks, Erik Verstraeten, Pierre Vérot, Damien Delas, Christine Lensel-Martinat, Marc Declerc, Naji Freiha, Romain Arend, Olivier Vimard, Patrick Tetu, Anne-Claire Balençon, Alain Probst, Yannick Vandewynckel, Joris Van Helleputte, Huseyin Uyar, Mustafa Aydin, Sinan Gül, Şenol Kahraman, Tom Dewyspelaere, Ronny Langendries, Marc Ronvaux, Laurent Balthazar, Joao Garcia, Thomas Alderweireld, Olivier Debliquy, Nicolas Van Oystaeyen and Nico Demuijnck shared their financial expertise with the interpretation of the statistical results. Lyn Thomas, Jos De Brabanter, Bart Hamers, Gerd Castermans, Karlien Vanden Branden, David Martens, Johan Huysmans, Joachim Jacobs, Steven Monsaert and Hugues Jan gave us useful feedback with their expert knowledge on statistics, implementations, computations, project and database management. We sincerely thank Claude Piret, André Delasnerie, Henri Bonaque, Eric Hermann, Rudi Sneyers, Luc Leonard, Jan Vanthienen, Johan Suykens, Joos Vandewalle and Bart De Moor, for the opportunities they gave us to work on the many challenges of Basel II and for their moral support to complete this book series. Last but not least, we gratefully acknowledge our families and parents for their love, support and encouragement.

*This page intentionally left blank*

# Introduction

---

Credit risk, or the risk that money owed is not repaid, has been prevalent in banking history. It is a principal and perhaps the most important risk type that has been present in finance, commerce and trade transactions from ancient cultures till today. Numerous small and large failures, combined with the corresponding economic and social impact, further accelerated the importance of credit risk management throughout history. Credit risk management is a process that involves the identification of potential risks, the measurement of these risks, the appropriate treatment, and the actual implementation of risk models. Efficient credit risk management tools have been vital in allowing the phenomenal growth in consumer credit during the last 50 years. Without accurate automated decision tools, credit lending would not have allowed banks to expand the loan book with the speed they have. Nowadays, effective credit risk measurement and management is recognized by many economic actors, not in the least because of financial failures of banks themselves. The recent Basel II capital accord articulates new market standards for credit risk management and capital adequacy for banks. The level of capital, a cushion to absorb credit and other losses, is matched to the portfolio risk depending on the risk characteristics of individual transactions, their concentration and correlation. All organizations, including banks, need to optimally allocate capital in relation to the selective investments made. Hence, efficient tools and techniques for risk measurement are a key cornerstone of a good credit risk management.

Where retail credit scoring has been one of the earliest successful financial risk management tools, developed initially by large US retailers, at the same time as the development of portfolio risk management, its success made it an excellent ambassador of quantitative modelling techniques for use in other asset classes. Electronic data availability and computation power, which increased exponentially over time, enabled the development and application of advanced statistical modeling techniques to support credit risk measurement, management and decision making in various types of asset classes.

## **xii Introduction**

Complementary to the existing judgmental risk management processes, risk quantification evolved to become an indispensable foundation of modern risk management.

It is the objective of this book series to provide an overview of all aspects, steps, and issues that should be considered when undertaking credit risk management. The book series is written for both practitioners (e.g. financial managers, consultants, auditors, regulators, . . .) as well as academics (lecturers, students, researchers, . . .). All three books aim at providing a solid technical basis without losing the focus on practical implementation. The first book lays the foundation for the next two by defining and reviewing some basic nomenclature and risk management concepts. This book is very useful for readers requiring a high-level understanding of the various concepts. Book II goes into the technical details of how to develop credit risk systems in a quantitative way. This is especially useful for those responsible for implementation or academics doing quantitative research. It provides both the introduction to the techniques and practical examples to guide young and experienced practitioners and academics in the fascinating, but complex world of modelling. Book III then discusses model risk control and follow-up. This will be especially targeted towards model validators, auditors, regulators and/or people doing research on model monitoring and follow-up.

Book I is primarily intended for newcomers in the field who need a global overview of the different concepts of risk management, measurement and modelling, without knowing the technical details discussed in the other two books. It introduces financial risk management and measurement, with the focus on credit risk. Default, loss and exposure risk, defined at a certain maturity, are the risk components that define the credit risk of a single transaction. The various types of credit scores and ratings to indicate these risk components are discussed first. The entire process to construct scoring and rating systems to predict, monitor and measure credit risk at the counterpart and transaction level, is discussed next. This is followed by an overview of portfolio models that calculate how the risk of a whole portfolio depends on the risk levels of the individual products, the concentration of large exposures and the correlation between the risk levels of the different products. Book I concludes with an overview of the Basel II capital accord and a discussion of the practical business impact.

*Tony Van Gestel  
Bart Baesens*

Brussels, Belgium  
August 2008

# Chapter by chapter overview

---

Chapter 1 introduces risk management and defines some basic banking concepts needed in the subsequent chapters. It starts by giving an overview on banking history (section 1.2). Next, the economic role of banks as financial intermediaries and brokers is reviewed (section 1.3). The bank's organization and balance sheet reflect the different activity types (section 1.4). These activities are not without risk: banks are exposed to different risk types, of which the most important are credit, market and operational risk (section 1.5). The key concepts of sound risk management practices to control these risks are then reviewed (section 1.6). Because banks have a central role in the economy, they are regulated to make sure that their capital cushion is aligned to their risk profile (section 1.7). This capital cushion serves to absorb losses and to protect the depositors' funds. The chapter is concluded with an overview of financial products (section 1.8), each with its different risk characteristics.

Chapter 2 provides an introduction to credit scoring. The different types of scoring that are nowadays being observed in industry, and how they relate to one another, are discussed first. Scores are used at different stages of the customer life cycle: marketing, application, performance, collection and profit scoring (section 2.2). Another classification is based upon the properties of the score (section 2.3): the purpose, risk type and risk entity, and internal/external score author. Credit bureaus are a popular external reference source for credit scores (section 2.4). The practical use of scoring systems is discussed in the remainder of this chapter. When scores are assigned automatically, human expert judgment may adjust the score outcome and credit decisions. The reason and number of overrides provides useful information on the quality perception of the scoring system (section 2.5). Credit scores are used for many purposes. In a credit risk context, their use concerns credit

decisions and portfolio risk monitoring, to advise in the pricing and to support securitization transactions (section 2.6). Their limitations are discussed in section 2.7.

Chapter 3 on credit ratings complements the chapter on scoring. Like scores, credit ratings order the credit risk. In addition, ratings represent the risk level into a limited number of categories. These and other differences between scores and ratings are reviewed in section 3.2. Ratings are so important that a specific terminology has developed. Concepts like rating actions, qualifiers, watchlist and outlook are introduced (section 3.3). Next, an extensive overview of rating types is given (section 3.4): ratings express credit quality on different maturities; on issuer and issue level; in terms of probability of default, loss given default, exposure, or expected loss; in terms of local or foreign currency; in terms of stand-alone risk, support or sovereign risk . . . With these elements, the generic architecture of a rating system is described (section 3.5). The ratings can be expressed using different philosophies: point-in-time ratings take into account the current economic conditions for rather short-term horizons, while through-the-cycle ratings take into account conservative assumptions during the whole business cycle on a longer-term perspective (section 3.6). Next, external rating agencies and their rating processes are discussed in section 3.7, while internal rating systems in banks are discussed in section 3.8. These ratings are applied for investment decisions, credit management on issue and portfolio level, for regulatory capital calculations, pricing and performance measurement, structured products, and credit risk reporting (section 3.9). The chapter is concluded with a critical appraisal of the limitations of credit ratings (section 3.10).

Chapter 4 on risk modelling and measurement gives an overview of the entire model development life cycle, discussing every step in detail, without focusing on mathematical and technical aspects. This chapter is especially useful for financial practitioners who are involved in the development, management, implementation and use of risk models. An overview is provided of the different aspects of risk measurement and modelling: data, modelling techniques and implementation for use. The life cycle of a rating system is presented in section 4.2. Next, the general overview of credit scoring models introduces the different classes of rating systems: structural, statistical and expert models, and human expert ratings (section 4.3). Most models rely on data, for risk measurement, model use and for model development. Risk data collection involves a definition of default, and a calculation methodology for exposure at default and loss given default for the identified defaults. In addition, the explanatory variables, that drive the differences in risk levels, need

to be identified and collected (section 4.4). Once the data is collected, the model development starts and involves the model choice, the score function construction, the segmentation into risk classes or ratings, and the calibration into quantified risk levels (section 4.5). Next, implementation aspects are discussed (section 4.6). Credit scoring models are not static applications, but dynamic instruments that are used in continuously evolving and changing environments. Therefore, model maintenance and follow-up are required (section 4.7). Because the quality of the rating models has an important impact on the bank's operations, models are subject to strong internal and external control before being put into operation, and during operation. The different, but also partially overlapping aspects of model validation, quality control and backtesting are reviewed in section 4.8.

Chapter 5 introduces portfolio models. Whereas scores and ratings concern the risk of individual transactions, portfolio models analyze the loss risk on a portfolio of credits. The loss distribution of a portfolio is the aggregated result of the risk of different securities in the portfolio, each with individual risk components: exposure at default, loss given default and probability of default (section 5.2). Common risk measures for portfolio risk are the expected loss, the loss standard deviation, the value-at-risk, and expected shortfall (section 5.3). The portfolio risk depends not only on the risk of the individual facilities, but also on concentration and correlation (section 5.4). Although high concentrations do not impact the expected loss, they increase the value-at-risk. Joint credit quality downgrades and defaults due to correlation also increase the portfolio risk. Portfolio model formulations are either based on simplified mathematical models or apply Monte Carlo simulations to generate joint losses due to correlated defaults and possibly also market losses (section 5.5). Popular industry formulations like CreditMetrics, Portfolio Manager, Portfolio Risk Tracker, Credit Portfolio View and CreditRisk<sup>+</sup> are reviewed (section 5.6). Next, the Basel II portfolio model for regulatory capital calculation is explained (section 5.7). Implementation and application aspects are reviewed (section 5.8). The chapter is concluded with the concepts of economic capital calculation, capital allocation and risk-adjusted performance measures (section 5.9).

Chapter 6 concludes this book with a detailed overview on the Basel II Capital Accord. The capital accord consists of three mutually reinforcing pillars. First, the components of bank capital are described (section 6.2). Pillar 1 defines the minimum capital requirements for credit, market and operational risk (section 6.3). Pillar 2 describes the supervisory review process to verify whether the bank holds sufficient capital to cover all its risks



(section 6.4). Pillar 3 defines the market disclosure to catalyze prudential risk management and sufficient capitalization (section 6.5). After the description of the new capital accord, the practical impact is discussed. It has important implications for the bank's information and communication technology: data needs to be collected on various levels: risk information, exposure, loss measures; computation engines calculate the risk on transactions and portfolios; data needs to be transferred correctly between different levels; and risk reports need to be communicated to regulators, senior management and the financial markets (section 6.6). The Basel II rules make capital requirements more risk sensitive, which will impact, a.o. (amongst other), the credit pricing and capital needs for banks with different risk profiles (section 6.7). A discussion on future evolutions concludes this chapter (section 6.8).

# 1. Bank risk management

---

## 1.1 Introduction

Banks and banking activities have evolved significantly through time [96, 105, 216, 246, 416, 508]. With the introduction of money, financial services like deposit taking, lending money, currency exchange and money transfers became important. Because of the central role of money, banks had and still have an important role in the economy. Banks act as brokers between supply and demand of securities, and they transform short-term deposits into medium- and long-term credits. Specialized information on financial products is gathered by banks to improve investment decisions and to manage the risk.

Like any other firm, banks are exposed to classical operational risks like infrastructure breakdown, supply problems, environmental risks, etc. More typical and important for a bank are the financial risks it takes by its transformation and brokerage function [246]. A bank raises funds by attracting deposits, borrowing on the interbank market or issuing debt instruments on the financial market [96]. Essentially, the bank's main activity is to buy and sell financial products with different profit and risk characteristics. This transformation from supply to demand side is not without risk. Banks are exposed to credit, market, operational, interest rate and liquidity risk. The appropriate management of these risks is a key issue to reduce the earnings risk of the bank, and to reduce the risk that the bank becomes insolvent and that depositors cannot be refunded.

In this introductory chapter, a broad overview of banking and risk management is given. A nutshell overview on banking history is reported in section 1.2. The key role of banks in the economy as brokers and financial intermediaries is reviewed in section 1.3. From the structure of the bank balance sheet discussed in section 1.4, it becomes clear that banks use a high leverage to generate an acceptable level of profit. The high leverage requires

## 2 Bank risk management

a proper understanding of the financial risks a bank takes, which are enumerated in section 1.5. The main issues concerning the management of these risks are discussed in section 1.6. Because of their central role in the economy, banks are subject to international and national regulation as explained in section 1.7. section 1.8 concludes the chapter with an overview of financial products. For more extensive information, the reader is referred to general books on the banking activity, like [98, 110, 174, 311, 342, 412, 419].

### 1.2 Banking history

The banking industry has a long history and has had an important influence on the economy and even politics [105, 216, 416, 508]. The development of banks is strongly related with the development of money in any form.

Barter was the earliest form of trade. Goods were produced by those who were good at it and they exchanged their surplus with others to the benefit of both. A crucial element for barter is the double coincidence of wants: both counterparts in the trade must be interested in the exchange of goods. Other problems are the indivisibility of some goods and the lack of a clear unit to calculate whether one makes a profit with barter. Man invented money as a means to make payments and to account for debts and credits [128]: it served to settle juridical disputes, to give religious tributes, and to be an intermediate commodity for exchange and trade. The indirect exchange with money overcomes the great difficulties of barter and was a great step forward in the economic development. Money is a highly divisible and durable commodity. In most countries and civilizations, gold and silver have been dominant commodities for money. Other types of money that have been used in past are, a.o., amber, cattle, cowries, eggs, grain, ivory, precious metals, rice, salt and seeds. The Inca society was unique in the sense that it reached a high standard, but did not use any kind of money.

Wealth in terms of gold and silver money is an easy target for thieves. In early civilizations, like Mesopotamia, the temple was considered as a safe place to store money: there were constantly people around, and the sacred place may have discouraged thieves. But while the money was stored in the temple, the government or other people active in trade may need it to finance projects. During the reign of the Babylonian emperor Hammurabi in the eighteenth century BC, records exist<sup>1</sup> of loans made by priests of the

<sup>1</sup> A stone tablet dated to around 2000 Before Christ (BC) has the inscription “Two shekels of silver have been borrowed by Mas-Schamach, the son of Adadrimeni, from the Sun priestess Amat-Schamach,

temple. Banking had become important enough to define laws to regulate banking operations.

Banking further developed during the Ancient Greek and Roman civilization [20]. Financial transactions like deposit taking, lending money and currency exchange were made by private entrepreneurs, temples and public organizations. Book transactions allowed customers to deposit money in one city and retrieve it in another city. Customers avoided the risky transport of large amounts of gold and silver coins. Normal interest rates were at around 10%, while risky operations had higher interest rates. Silver and gold coins were used as money. The Romans further improved and regularized Greek banking practices and improved administration, but still kept a preference for cash money.

The downfall of the Roman empire and the collapse of trade made banking less important. Coin money was largely abandoned in the first centuries after the Roman's defeat. In addition, interest rate charging was seen as controversial by the powerful Christian church. A similar interpretation is made in Islam, where the basic principle is the sharing of profit and loss, and where interest rate charging is forbidden. Banks do not explicitly charge interest, instead they are paid by profit margins on deferred payments and other mechanisms to compensate for the risk and the time value of money [331, 360, 364, 446]. In many other religions, interest taking was legitimate, especially when cattle or agricultural products were lent.

The banking industry kept simmering, until it revived in the twelfth century, when Jews started to provide banking services to finance the economic welfare. Moneychangers issued documents similar to bank notes that were exchangeable at other medieval trade fairs. The Order of Knights Templar provided banking services to kings and powerful families. Their demand notes were redeemable in local currency at their castles across Europe and the Holy Land. The success and religion of both groups made them vulnerable to envy and repression. Common people took over banking. North Italian bankers called Lombards took the place of Jewish bankers in the thirteenth century. Note that the term Lombard loan is still used today to indicate loans collateralized by, e.g., securities. Their commercial instinct and the invention of double-entry bookkeeping made their banking industry successful. They avoided the Christian sin of usury by creative bookkeeping

the daughter of Warad-Enlil. He will pay the Sun-God's interest. At the time of the harvest, he will pay back the sum and the interest upon it." [330, 475]

## 4 Bank risk management

where interest charges were gifts or rewards for the risk taken by the banker. In contrast, Papal bankers were the most successful in Western Europe and Florence was the financial capital of Europe. The Lombard moneychangers moved from city to city along important trade and pilgrim routes. Lombards were often pawnbrokers that lend money in exchange for collateral. Their leading position in international trade finance was supported by the florin, the benchmark currency. The Bardi and Peruzzi families made a fortune by banking, but their businesses went bankrupt in the fourteenth century, when Edward III, King of England, defaulted on a big loan during the Hundred's Year War with France.

Florence remained, nevertheless, a powerful financial centre. The Pazzi and the Medici families were prosperous bankers in the fifteenth century. The word "bank" originates from the Italian word "banca" that refers to the bench where the moneychangers did business on in squares. When one went bankrupt, his bench was broken or "banca rotta" in latin. This term still survives in the word bankruptcy that is nowadays generally used for firms in financial difficulties. At the end of the fourteenth century, there occurred a shortage of silver across the whole of Europe. As a consequence, many mints closed and banks failed.

Political forces turned against Italian bankers in many Western European countries after 1400. The Fugger family took over the leading financial role in the fifteenth century, when the center of European power changed to the Habsburgs. The Fugger family built its wealth on secured loans to local and national governments. Wartime forced kings and emperors to borrow money from bankers to finance their armies. Bankers, who were aware of past sovereign defaults, secured their loans with sources of royal income: tax revenues, silver mines, . . . Banking for kings was profitable. At the end of the sixteenth century, the Fugger family withdrew from its banking activities after some financial disasters, a.o., the default of Philip II, King of Spain. It became an aristocratic family.

Interest rates were legalized in England by King Henry VIII in 1545 with a maximum of 10% per year. Economically, the discovery of the new regions and continents broadened the scope of international trade and brought wealth to Europe. International trade, large-scale lending, joint stock companies and foreign exchange markets started to develop. The Royal Exchange was built in the mid-sixteenth century when London became a center for foreign exchange. However, there was also a downside: around 1600 there was almost a century of continuously high inflation, caused by a high inflow of

gold and silver from the colonies and by a high population growth without a corresponding increase in economic output.

Gradually, banking evolved from financial services to the rich and mighty to financial services to a broader range of customers. This type of modern, commercial banking emerged in the early part of the seventeenth century. Banks became organized into pawnbrokers, private banks, city exchanges, and state bankers. Pawnbrokers and private banks provided financial services for merchants and citizens. City exchanges and state bankers did business with the government and heads of state. An already mentioned example is the Rothschild dynasty that gave credit to Napoleon's enemies. The Rothschild bankers had an excellent reputation for reliability, efficiency and information quality throughout their European banking network.

A disadvantage of private banks was their high bankruptcy risk. Banks were not very safe and many banks disappeared in subsequent crises. Therefore, the Venice city state opened the state bank "Banco della Piazzo di Rialto" at the end of the sixteenth century. The state bank took deposits from merchants and enabled financial transactions by cheque – bill of exchange – without transfer of coins, as already occurred with the Ancient Greeks. The city state paid the bank's expenses. Other known city state initiatives were Barcelona, Genoa, Amsterdam, Hamburg and Nuremberg. In the late seventeenth century, the ports of Hamburg, Amsterdam and London were the largest centers of commerce, where important banking activities developed. Individuals could participate in the lucrative East India trade using bills of credit of the banks. Trade was, however, still a risky business, a.o., due to war, piracy, and ship losses. In London, coffeehouse keepers published a list of share prices and shipping data at their doors. This eventually led to the London Stock Exchange.

Meanwhile, the concept of city banks had evolved to national banks that were established by a partnership with the state. The bank of Sweden was founded in 1668 and is the oldest surviving bank today. It was the first chartered bank issuing notes in 1661. The bank of England started in 1694. It evolved to a central bank that organized the sale of government bonds, did clearing for government departments and became a bank for other banks in London, and through them the small private banks across the country. When one of the banks is in crisis, the Bank of England provides credit and acts as a lender of last resort. The banking industry developed further in the seventeenth century, a.o., with new banks founded in the Netherlands and public-owned banks in Germany.

## 6 Bank risk management

Coins and notes remained an issue in the eighteenth century. In regions where there was a shortage of coins, alternatives like signed notes or secured notes were used, e.g., in Virginia tobacco notes became legal tender. State banks were founded to issue notes and to support international trade. The British industrial revolution started in the mid-eighteenth century. It was supported by the development of banks throughout the country. Banks specialized in lending to certain industries, while building societies focused on mortgage lending. Capital access allowed hard-working entrepreneurs to set up and expand business without much state intervention in economic affairs. This form of capitalism was later copied by companies in the United States. At the end of the eighteenth century, banking activity boomed. Savings banks were established in Germany together with private banks, while country banking spread in England and Wales. Most banks had close relations with particular industry activities. The first building society was formed in Birmingham to save money to build and purchase houses for their own occupation. Scottish banks developed well with branches and agencies spread across almost the whole country, although it also faced a banking crisis with the collapse of Ayr bank and a dozen other private bankers. More conservative, older Scottish banks survived. Banks were founded in Russia and in the United States, with the Bank of Pennsylvania, Bank of North America, Bank of New York and the Bank of Massachusetts amongst the first banks after the independence declaration from Britain. The Bank of New York is the oldest US bank today. The Rothschilds banking network expanded to England to target the cotton industry. Later, the family played an important role during the Napoleonic wars and was an important moneylender for Napoleon's opponents. The French national bank was founded in 1800.

In the nineteenth century, banking activity and technology developed further. The number of banks in the US grew steadily. The Bank of Bengal was the first presidential bank founded in India, a British colony, to supplement internal money supply during the British rule. Centuries before, selected Indian castes provided credit, collected deposits and arranged trading deals. Other Asian banks were founded in the same century to support money supply and foreign exchange.

The industrial revolution spread to the continent first in Belgium, where the Société Générale played an important role in its development. The National Bank of Belgium was founded in 1850. The savings bank movement developed further in Britain and spread to France and the Netherlands. Clearing systems developed to clear interbank accounts in the US and later in the

UK and France. In Germany, agricultural and industrial credit co-operations were founded. The Bank of Prussia was created from the Royal Giro and Loan Bank and developed later into the German national bank. In the second part of the nineteenth century, new French banks were founded, a.o., *Crédit Agricole*, to support economic development. At the end of the nineteenth century, the Bank of Japan was founded after the Belgian national bank model. The banking industry develops rapidly in Japan with industrial, agricultural and hypothec banks.

The war between the US and Britain had its impact on banking. The bank of the United States charter was not renewed for political reasons, a.o., the presence of UK shareholders like Barings Bank. Without control of the central bank, many banks issued new notes backed by species, causing inflation during the war. The second Bank of the United States was founded to restrict note issuing. After the US banking crisis in the mid-nineteenth century, it collapsed.

Although there were many new developments, there were also several banking crises. In England and Wales, about 60 banks failed during the crisis of 1825–1826, which is blamed on smaller, weaker country banks that issued too many small notes. The liquidity shock was relieved by the Bank of England and the Royal Mint that brought additional money into circulation. The uncontrolled development of banks in the US was stopped by a financial crisis in 1837 that resulted, a.o., in the crash of the Second Bank of the United States. Many regional banks in France were weak and failed during 1847–1848, fortunately the Bank of France filled the gap. In 1857, a crisis in the US forced banks to suspend specie payments. Because of the important European investments in US banks, the crisis was contagious and hit mainly UK banks and the newly founded German industrial banks. Silver and especially gold became a standard to backup notes. US national banks were created in 1863 to provide funding for the civil war and to create a uniform national currency. These national banks were subject to higher standards than state banks and were supervised by the office of the “Comptroller of the Currency” (OCC). Banks also learned from past experiences: during the next US bank panic, notes were used for interbank transactions, while gold was available for the panic-struck customers.

In the early 1900s, New York started to emerge as a world financial center. Individuals and companies from across the United States, but also from Europe, were active depositors and borrowers at the New York banks. New York was a contact point where European and US financial markets met. In 1907, New York was hit by a financial crisis that caused hundreds of banks to



## 8 Bank risk management

fail. Although the crisis spread across the world, damage in other countries like Britain was limited. It motivated the creation of a system of central banks. The Federal Reserve was created via the Federal Reserve Act in 1913 as a system of 12 Federal Reserve Banks in an equal number of districts. Each bank had several member banks, amongst which were the state banks.

At the same time, new evolutions like postal giro systems kept on changing banking practice. The French giro system became a success, partially because of the mistrust against cheque payments.

During the first World War (1914–1918) the importance of New York banks grew steadily by lending all over the world, including both parties in the conflict. In the US, stock markets boomed until the Great Crash in 1929. It was the end of the New York bank expansion. Stock markets crashed everywhere at the same time. Many banks failed during the Great Depression period that followed. It was a global, systemic event that was too big to cure by a state or regulatory intervention. Many borrowers defaulted and the bank's assets declined significantly in value. In the last quarter of 1931, more than 1000 US banks failed.

Banks were also blamed because of their speculative activities during the 1920s and measures were taken. Banking activities became more regulated by the governments: commercial banking and securities activities were separated by the Glass–Steagall Act in the US, Chase National Bank and City Bank chose for commercial banking and disbanded their securities activities, while Lehman Brothers became an investment bank without deposit collection activities. JP Morgan continued as a commercial bank, and part of the management left to create the Morgan Stanley investment bank. Such a split up in activities was not done in Europe, where most institutions remained universal banks.

In the United States, the Federal Reserve system was already created. By providing liquidity through central bank refinancing, the system aimed to reduce bank failures by serving as a lender of last resort. In addition, the Federal Deposit Insurance Corporation (FDIC) started to give an unconditional guarantee up to \$2500 for most creditors of American banks in 1933. It also had the power to restrict dividends and the interest rates offered by banks on deposits. As a result of the 1929–1939 crisis, a fixed level of capital, independent of the bank's risk profile was requested. Although the capital level was not risk sensitive, banks were forced to have an equity buffer to protect depositors in adverse economic conditions and severe bank losses.

It is worth noting that other regional bank crises also occurred in the meanwhile. A crisis in Taiwan, a Japanese colony, spread to Japan in 1927,

where 37 banks were closed, some of them temporarily. In 1931, German banks got into financial distress and many of them failed, a.o., the Austrian Creditanstalt Bank. On the international scene, the Bank of International Settlements (BIS) was founded in 1930 to help with reparation payments after the first World War, and with large financial transfers for reconstruction. This task quickly faded away and it focused on the co-operation between central banks. It became the main forum for central bankers and other agencies in pursuit of financial and monetary stability.

### 1.3 Role of banks

Banks are firms that efficiently provide a wide range of financial services for profit. Not surprising, banks have an important role in the economy and the society as a whole. Their central role is to make the community's surplus of deposits and investments useful by lending it to people for various investment purposes: company growth, education, houses, . . . (Fig. 1.1). In a simple representation of the economy, there are households who buy goods and services, produced by firms. Their expenditure generates revenues for these firms. To produce goods and services, firms have a need for production factors (labor, capital, knowledge, . . .) that are obtained from

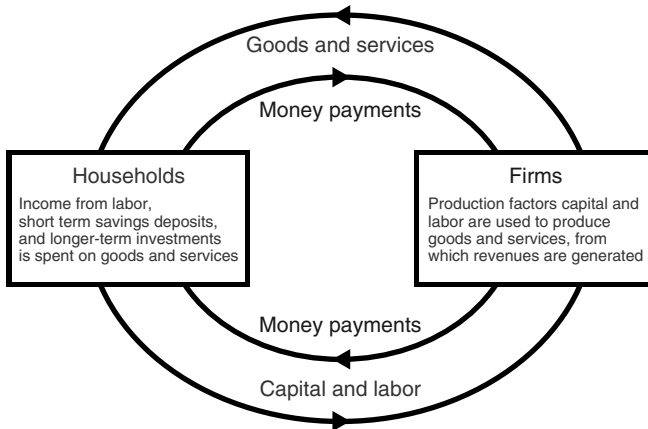

**Fig. 1.1** A simple representation of the economy. Households spend their income on goods and services from firms. Firms produce with capital, labor and knowledge from households in return for salaries, interest and dividend payments. Banks play a central role in the capital flow from households to firms: short-term deposits from savers and investors are transformed into short-, medium- and long-term loans. In addition, banks process most of the payment transactions.

## **10 Bank risk management**

factor markets, that are supplied by households, from which they generate their income. Note that the circle is not perfectly closed, there are leakages, e.g., to the government. Capital is passed from households to banks and financial markets, while banks also carry out payments.

Banks have a main role as a financial intermediary that provides a steady flow of funds from savers to borrowers and users. They generate profits from transaction fees on financial services and interest charges for lending, which corresponds to two of their main functions as financial intermediary: brokerage and asset transformation. Banks also started to provide additional services on top of deposit taking, lending, stock broking, money transactions and payment systems with the aim to make additional profits from cross-selling, e.g., from insurance and investment products.

The discussion of the brokerage and asset transformation function of a bank is given in the next two sections. The activities and business lines of a universal bank are described in section 1.3.3.

### **1.3.1 Brokerage function**

In the brokerage function, banks act as an agent or intermediary in a financial transaction, e.g., on the stock or bond market. The broker can represent a buyer or a seller of a financial asset, and buys or sells on behalf of the customer. The broker facilitates the trade and its execution, he matches the buy and sell sides of the market and brings them together. Note that the nature of the traded financial product is not changed by the broker.

Transaction and information costs are reduced significantly by the broker, who benefits from important economies of scale regarding information-gathering and trade-execution systems. In most cases, the broker asks a fee in exchange for its services. This fee can be a fixed or percentage-based commission, or a combination of both.

### **1.3.2 Asset transformation function**

The asset transformation function translates the product specifications requested by the savers to products requested by the borrowers. Savers, e.g., retail deposit savers, are more attracted by products with lower price risk, liquidity costs and monitoring costs. Borrowers, e.g., large corporations are more interested in long-term debt but have higher risk, i.e. the uncertainty that they pay back the debt is higher. Banks transform the safe, short-term and liquid small amounts of savings deposits to the risky long-term debt to

firms or firm borrowers. In the asset transformation process, the characteristics of the funds that flow from savers to borrowers is changed. The bank invests the assets of the savers in a diversified way. Households with smaller units of assets opt for a low-risk investment, with correspondingly lower return. By a good diversification, banks can invest these assets in larger units with lower transaction costs, higher risk and better return. By exploiting the law of large numbers on a diversified portfolio, the total risk reduces for the benefit of the depositors and the equity shareholders. Banks have a sufficient number of risk experts to analyze the risk profile of the borrowers. They have better and lower-cost access to specialized information, which is costly and difficult to interpret for individual household investors.

The asset transformation function of the financial intermediary is a necessary function in the economy. Because of the differences between the objectives and risk profiles of the stakeholders of a firm, there is a need for both debt and equity. The household savers', flow of funds is transformed to the needs of firms. This function is necessary to achieve a global economic optimum. In their role as financial intermediary, banks reduce market deficiencies on three domains:

**Liquidity intermediation:** The bank matches the objectives of two main groups in the economy: consumers and investors. Consumers and household savers have a short-term horizon on which they want to optimize their utility function. Consumers prefer a smooth consumption pattern to minimize changes in utility and hold liquid reserves to absorb temporary shocks in purchasing power, e.g., due to unemployment or unexpected expenses (e.g., a broken car). Investors need long-term financing for long-term projects and may have short-term cash difficulties. This financing bears a higher risk. Such loans or debt is illiquid for who provides it.

Banks provide deposit savings accounts that provide the liquidity insurance for the consumers. The cost of the liquidity premium is covered by a reduced interest rate. At the same time, banks use the savings deposits to provide the long-term illiquid investments. This is possible when the amount of deposits a bank holds is sufficiently stable over time by the law of large numbers.

**Risk intermediation:** Banks provide low-risk saving deposit products to consumer savers and invest their deposits in more risky firm debt and other assets. This is possible by a good risk management and sufficient diversification. Banks hold sufficiently diversified portfolios in which the risk of an individual loan is reduced. Not all loans will default at the same

## 12 Bank risk management

time. In general, banks transform different types of risk (credit, market, exchange rate, interest rate risk, . . .) and repackage it into an appropriate product for all economic agents. Another example is the securitization activity, where a risky portfolio is structured into various products with specific risk profiles tailored to the needs of different economic agents.

**Information intermediation:** Information gathering is important to avoid economic pitfalls due to asymmetric information. Firm entrepreneurs are typically much better informed than the consumer savers. Such information asymmetry may have adverse impacts on the economy known as the moral hazard and adverse selection problem. Because of the asymmetric information, the savers are not able to discriminate between high- and low-risk borrowers and, therefore, will tend to charge the same interest rate. This will discourage high-quality borrowers with low risk and only high-risk borrowers remain on the debt market. Savers are left with no other choice than investing in high-risk borrowers. The resulting bias is called the adverse selection bias in microeconomic theory and occurs at the beginning of the loan or financial contract [4]. The moral hazard bias can occur during the contract. Because the borrower or entrepreneur has more information than the lender, the borrower can be tempted to take more risk so as to maximize his profit or extract undue value from the project, without the lender noticing his disadvantage. This gain in profit is to the disadvantage of the value of the firm. A good debt contract and direct surveillance are adequate remedies [85, 86, 111, 133, 144, 204, 478]. Sufficient surveillance will discourage the entrepreneur from behaving suboptimal. If he were caught, the bank would stop the relationship and the entrepreneur finds his reputation damaged and has no funding for its investments.

It is time consuming and costly for individual savers to gather information on firms. Banks have the means and the leverage for efficient information gathering, processing and analyzing to tackle moral hazard and adverse selection. They can make one analysis for all their depositors, while each saver would have to spend a lot of time analyzing many borrowers. In this framework, banks have the role of delegated monitors for the community of savers [144].

In a theoretically perfect and efficient economy, actors or agents (borrowers, investors, lenders, savers, consumers, . . .) have been shown to be indifferent between the major sources of capital funding: debt and equity. In such an economy, equity investments on the financial markets should be sufficient

for funding firm and project investments and bank lending is not absolutely required [362]. However, such an economy does not exist in practice: there is information asymmetry, incomplete contracts, tax friction, . . . In imperfect financial markets, there is a need for both debt and equity. Banks have specialized on debt management. They transform their own debt to savers as a resource to transform it to loans for firm and other borrowers in general. In banking theory, the bank is defined by its mission for the benefit of the economy. In microeconomic theory, a bank is the most adequate coalition of individual agents that fulfills the three intermediation functions mentioned above [7, 8, 145, 194, 356, 402]. The most adequate coalition indicates the Pareto optimum: the utility function of one agent cannot be improved without reducing the utility function of another.

The increasing efficiency of financial markets tends to reduce the difference between debt and equity. Simultaneously, the differences between banks and the financial markets becomes more vague. Banks also tend to put more emphasis on the brokerage function instead of the transformation function. With choice of the brokerage function, they generate a fee business that is based upon marketing and distribution skills. In the asset transformation function, income generation results from risk taking and management. The optimal mix between the brokerage function is a strategic management decision based upon risk-return performance.

### 1.3.3 Activities of a universal bank

An overview of the different activities of a universal bank is depicted in Fig. 1.2. Together with its main function of financial intermediary, also related functions like investment banking and brokerage gained importance. Important functions in a universal bank are:

**Core bank activities:** The core bank activities are financial services (deposits, loans, current accounts, . . .) to various groups of customers. The retail bank specializes its services to retail customers (residential mortgages, personal loans, credit cards, current accounts, payment systems, foreign exchange, saving accounts, forward accounts, . . .), while the commercial banks specialize to small and large companies (commercial mortgages, loans, trade finance, overdraft facilities, cash management and payments, current accounts, deposits). Public sector entities, local and regional governments have specific needs, amongst which are short-term and long-term loans to finance their operations, investments and further

## 14 Bank risk management

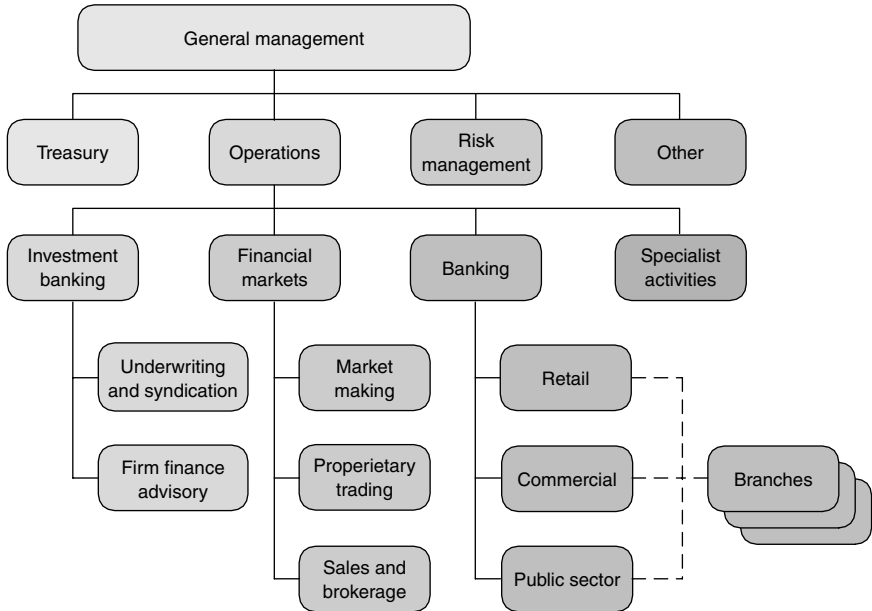

**Fig. 1.2** Scheme of the organization of a universal bank. The operations of the bank consist of the business lines: investment banking, financial markets, banking and specialist activities. The investment banking part of the bank does underwriting and syndication of new securities and provides advisory services to firm customers. The financial market's activities are market making, brokerage, sales and trading for the bank. The banking part itself is specialized into financial services for retail customers, for small, medium and large companies in the commercial bank, for public sector entities, and for sovereigns. The contact with the customers is via a network of branches that may partially overlap for the different customer groups. Private banking, asset management, custodian banking and brokerage firms are generally considered as specialist activities. Bank-insurance groups also have an insurance business line in their operations with life, non-life, financial and reinsurance activities. Some of these activities are distributed using the same network of branches. The treasury services are responsible for the funding needs of the bank to support the other activities. The risk management watches the risks the bank is exposed to by its different activities. Human resources, information technology, logistics and audit tasks are grouped under other activities. The scheme sums up the main activities of the bank, depending on the bank and its organization.

development. These services are brought to the customers via a network of branches. These branches can be specific for the different customer types or can overlap, e.g., branches for retail customers and small companies. Overlaps can also exist for insurance services and wealth management, where the bank's branches serve as agents.

**Financial markets:** Many activities of the financial markets are located in and related to the dealing room of the banks. The proprietary trading desk makes investments for the purpose of the bank. Financial products can be

bought or sold publicly, over the counter on stock markets and exchanges; or under the counter via bilateral exchanges with other financial institutions. Banks themselves also help in defining a “financial market place” together with brokers, clearing houses and stock exchanges. The market-making activity of the bank determines the prices at which financial assets can be bought and sold. The market maker brings the supply and demand for financial assets together by publishing buy and sell prices at which he is prepared to make an intermediary trade with the buyer or seller. The price difference or buy–sell spread is the fee for the market maker to cover his operational costs, risk and investments. In the brokerage function, the bank provides products tailored to the needs of the customers.

**Investment banking:** The first role of investment banking was historical to raise funds for governments and companies. They underwrite the loans that are then sold to the large public of investors. In exchange for their efforts to sell the securities, the investment bank receives a fee. Investment banks also take a leading role in syndicated loans, which are loans that are so big that many banks participate in them to reduce the concentration risk. Investment banking also includes pre-underwriting consultancy, advisory and guidance. Expert guidance on complex financial engineering products, like hedging is also part of the consultancy mission. By their large firm customer base, the investment banking departments know which firms have excess cash to acquire other firms, which firms are looking to be bought and which firms are looking for a merger. External merger and acquisition consultancy has become a profitable, but conjuncture-dependent activity of commercial banking.

Different types of banks have an emphasis on different activities. A universal bank combines all types of services. Retail banks focus on the retail banking activities and other synergies of the retail network as agents for insurance companies and wealth management. Savings banks and building societies also conduct retail banking. They provide savings products and mortgages to all strata of the population. Postal savings banks have a similar profile. Their network is associated with national postal services. Commercial banks focus on all pure banking aspects. In the US, commercial banking referred to pure banking activities, while investment banks focused on the capital markets. Merchant banks focus on large customers and do not invest in a large retail network. They were traditionally specialized in trade financing. Nowadays, the difference from investment banks becomes more and more



## 16 Bank risk management

vague. Investment banks focus especially on the investment banking activity and the financial market activities. They do not provide retail services, except for the very rich private banking clients. Private banks focus on financial services and asset management for very rich individuals. The separation of commercial and investment activities was enforced by law after the Great Depression. Nowadays, separate ownership is no longer imposed, which resulted in the creation of universal banks or a financial services company. Such banks meet the growing demand of customers for “one-stop-shopping” by providing all products at the same time and place. Specialist activities are private banking, asset management, custodian banking and stock brokers. The first two activities are related to wealth management: private banks are specialized in providing dedicated and specialized financial services to very wealthy individuals and families. Asset management makes investments on behalf of customers, e.g., via mutual funds. Asset management refers to the professional management of equities, bonds, real estate, . . . on behalf of retail customers, private bank customers, insurance companies, pension funds and firms. For the retail business, they offer collective investment schemes (e.g., mutual funds and undertakings for collective investment in transferable securities, UCITS) that allow investment in a wider range of investment types with limited amounts. Custodian banks hold in safekeeping assets (equities, bonds, . . .) on behalf of its customers and also arrange the settlement of purchases and sales, collect income (dividend, coupon payments), gather information, and generate regular financial activity reports for their customers.

In most countries, central banks are non-commercial bodies or (supra-national) government agencies that are responsible for controlling interest rates and money supply. Their monetary policy aims to create stable economic growth and they promote international financial stability. Often, bank supervisory bodies are attached to central banks or work in close co-operation with them. Central banks act as a lender of last resort in the event of a crisis. In most countries, central banks issue bank notes and coins.

The two key remaining services in Fig. 1.2 are the treasury and risk management. Other supporting activities are, a.o., information technology (IT), logistics, human resources, compliance, and audit. The treasury services are responsible for the funding needs (e.g., by the emission of bank debt) of the bank to support the other activities. The risk management watches the risks the bank is exposed to by its different activities. In this book, the focus is

on the risk management of the different banking activities and on its main component: credit risk.

## 1.4 Balance sheet

The activities of the bank determine the structure of the balance sheet of the bank. Retail banks will have a lot of retail-related products on their balance sheets, while the direct activities (a.o., consulting) of investment banks are less visible in balance sheets. Investment banks typically have short-term exposures, the assets remain on their balance sheet until they are sold.

A balance sheet is a formal bookkeeping and accounting term that provides a statement of the assets (activa) and liabilities (passiva) of the firm on a certain date. The balance sheet is a picture of the firm. The assets generate direct or indirect profit: stock/inventories, accounts receivable, machines, buildings, cash. The liability part consists of debt to debtors (long-term bank debt, debt with providers, short-term debt) and liabilities to the owners of the company (equity). By the principle of double-entry bookkeeping, both sides of the balance sheet sum up to the same amount of total assets or total liabilities. The difference between the assets and liabilities to debtors is the net worth. It reflects the value the equity holders would receive in the case of liquidation of the firm.

A bank generates its main income from financial assets, a big part of these are loans to individuals, banks, companies and governments. These loans are financed by debt to depositors, other banks, institutional investors. The composition of the balance sheet reveals its main business activities. For a universal bank, the balance sheet has the structure depicted in Table 1.1. On the asset side, the following entries are the most important:

**Cash and liquid assets:** Cash and liquid assets are held as a liquidity reserve, most of these assets are held with central banks. Central banks may demand a deposit of a proportion of the bank's assets. Such a fractional reserve is an issue of monetary policy and can be used as a tool to control money supply. Minimum levels are set as part of banking regulation.

**Government securities:** Government securities and bonds are financial instruments issued by sovereigns. Good-quality paper is eligible for central bank refinancing to provide additional liquidity.

**Table 1.1** Balance sheet of a bank. The assets generate income that serves to pay the expenses due to the liabilities. For a classical commercial bank, the most important assets are interest income generating assets: loans and securities. These assets are paid with loans, deposits and debt securities on the liability side. The reserves, etc. are part of the “capital” of the bank, which is typically a small proportion of the balance sheet. The net income/net loss of the year is added/deducted from the “capital” owned by the shareholders. The sum of the assets is equal to the sum of the liabilities. The gearing (total assets/equity) of this bank is equal to 30.5.

Assets (Activa)	€(million)	Liabilities and equity (Passiva)	€(million)
Cash, central banks and postal checking accounts	7.9	Liabilities	413.1
Gov. sec. eligible for central bank refinancing	8.7	Interbank loans and deposits	102.4
Interbank loans and advances	76.2	Customer deposits	152.9
Customer loans	130.2	Debt securities	121.2
Bonds and other fixed-income securities	90.0	Accruals and other liabilities	8.7
Equities and variable-income securities	70.1	Derivatives	16.4
Derivatives	17.4	Provisions	3.4
Long term investments	20.0	Subordinated capital	8.1
Intangible assets	0.9	Equity	14.0
Property and equipment	1.5	Subscribed capital	1.7
Fixed assets	1.2	Capital reserve	5.8
Other assets	3.0	Retained earnings	4.1
		Consolidated profit	0.4
		Other reserves	1.1
		Minority interests	0.9
Total Activa	427.1	Total Passiva	427.1

**Interbank loans:** Banks with a surplus on funding lend money to other banks on the interbank market. The maturity varies from days to months. The benchmark interest rates for such assets are the Euribor and Libor.<sup>2</sup>

**Customer loans:** The loans made to various customers of the bank: retail, small firms, medium-size firms, large firms and specialized lending. There are different products ranging from credit cards and overdraft credits on current accounts, to unsecured investment loans and secured loans like mortgages. The maturity of such loans can vary from less than one year to several years. The composition of the customer loans gives a good overview of the bank's investment and business strategy.

**Bonds and fixed income securities:** Bonds have, like loans, typically a fixed interest rate specified in the contract. Bonds are issued by other banks, firms and also governments to raise money from capital markets. Although the product is similar to a classical loan, this product is open for every kind of investor (individuals, investors, pension funds, banks, . . .). When banks buy bonds, they appear on this balance sheet entry. As for loans, the investment strategy and risk appetite of the bank will determine the decomposition of the bond portfolio. Bonds and loans are fixed-income products: unless the customer or bond emitter defaults, they provide fixed revenues.

**Equities and variable-income securities:** These assets include derivative products, trading investments and equity investments. These investments do not guarantee the income stream. The income from these assets is more volatile. As a compensation for the higher risk, these assets should provide a higher return on average.

**Long-term investments:** These assets are strategic investments of the bank held for a long term, e.g., equity investments in large companies, other banks or insurance companies.

<sup>2</sup> The Libor is short for London Interbank Offered Rate. It is the benchmark interest rate used for interbank borrowing offered by the major London banks and published by the British Bankers Association. It is a reference interest rate for unsecured funding in Pound Sterling (GBP, £), US dollar (USD, US\$), but also the Swiss Franc (CHF), the Yen (JPY, ¥) and the Canadian dollar (CAD). Similar rates exist in other markets, like the Pibor in Paris, the Fibor in Frankfurt and the Ribor in Rome. The latter rates merged into the Euribor (Euro Interbank Offer Rate), which is the benchmark interbank rate offered in the Euro zone for unsecured funds in Euro (EUR, €). It is fixed daily at 11 am Central European Time by the European Banking Federation. These rates also serve as reference rates for derivative products like forward rate agreements, futures contracts and interest rate swaps.

## 20 Bank risk management

Among the other asset-side entries are mostly fixed assets (e.g., buildings) or assets related to the bank's operation. These assets are not a large fraction of the balance sheet.

On the liabilities side, the balance sheet is composed of various product types. Banks raise funds by attracting deposits, by borrowing money from other banks on the interbank market and by issuing financial instruments. The main debt liability types are:

**Interbank loans and deposits:** The bank borrows from other banks to bridge short-term funding needs or accept deposits from other banks.

**Customer deposits:** Deposits on current accounts and saving accounts are a major funding source for most commercial banks. These deposits may not have a specified maturity date. Depositors may retrieve their money at any time. In general, it becomes unlikely that a large group of depositors would retrieve their money in a short time. Sometimes, this risk is called behavioral risk.

**Debt securities:** Funding is obtained by issuing debt securities on the capital market. A classical funding source are bonds issued by the bank.

**Subordinated debt and hybrid capital instruments:** Subordinated debt is more junior and subordinated to other debt types. In the case of a bank failure, the debt contract specifies that the more senior debt holders (depositors, debt securities holders) are reimbursed first. Hybrid capital has aspects of debt instruments and equity that has lower priority rights than senior debtors in the case of failure.

The debt liabilities are due to external investors. Although these instruments are due to external investors, this liability is often seen as capital from the bank regulation perspective because of their lower priority in the case of failure. The bank itself has also liabilities to its owners, the shareholders.

**Reserves:** A financial buffer for downturn periods owned by the shareholders of the bank.

**Banking risk reserves:** Bank investments in assets bear a certain risk. To cover the expected loss, banks build up a banking risk reserve.

**Capital stock:** Capital invested by the shareholders in the company.

The bottom part of the liabilities side is owned by the shareholder. These entries and the subordinated debt and hybrid instruments are largely part of the regulatory capital. Among the assets and liabilities, there are different

type of assets: variable and fixed interest rate instruments; liquid and illiquid instruments; short-term and long-term maturity products, as will be discussed in section 1.8.

The bank management accepts liabilities and selects the investments in assets to make profit for the shareholders. Income is generated from assets and fee business. On the asset side, interest revenues are obtained from most of the assets (cash, short-, medium- and long-term assets, securities). The bank also receives fees from its business activities (credit granting fees, brokerage commissions, asset management, . . .). For the liabilities (deposits, funding and securities), interest expenses need to be paid. The bank also has operational costs (personnel expenses, infrastructure, marketing expenses and fees). In addition, the bank will also have losses from the investments it makes. The profit before taxes is the result of all income, expenses and impairment losses. This profit is subject to taxes. The net profit or net income (after taxes) is the return for the shareholders. It is distributed amongst the shareholders (dividend payments, reserves, share buy-back schemes) [218]. Such information is reported in the profit and loss (P&L) statement (Table 1.2). The Du Pont chart of Fig. 1.3 illustrates how profit for the shareholder is generated. A high return on equity (ROE = net income/equity) is obtained by a high equity multiplier<sup>3</sup> (EM = total assets/equity) and a good return on assets (ROA = net income/total assets):

$$\frac{\text{Net income}}{\text{Equity}} = \frac{\text{Net income}}{\text{Total assets}} \times \frac{\text{Total assets}}{\text{Equity}},$$

or

$$\text{ROE} = \text{ROA} \times \text{EM}.$$

A good ROA is obtained by a good interest margin (interest income of assets – interest expenses on liabilities), low operating costs (low losses, operating expenses, . . .), a good fee and trading income. The amount of taxes to be paid is determined by tax regulation. A good ROA is obtained by good banking skills by obtaining a strong net interest margin and by good management to control costs.

<sup>3</sup> The equity multiplier is closely related with leverage (total debt/equity).

## 22 Bank risk management

**Table 1.2** Profit and loss (P&L) statement of a bank. The primary source of income are interest revenues from the bank's assets that serve to pay the interests due on the bank's liabilities. Other sources of income and expenses are commissions and fees together with trading income or loss. The net banking income needs to cover general expenses, financial losses and taxes. The net income is the compensation for the risks taken by the shareholders. The intermediate results are denoted in bold italic scripts. The bank makes a total profit of €1.5 million. For the balance sheet of Table 1.1, the return on assets and the return on equity are equal to 0.35% and 11%, respectively.

Profit and Loss Statement	€ (million)
<b>Interest income</b>	<b>13.1</b>
Interest and fees on loans	5.8
Interest on deposits with banks	2.6
Interest on money market operations	1.3
Interest and dividends on investment securities	1.9
Interest on trading account assets	1.5
<b>Interest expense</b>	<b>7.8</b>
Interest on deposits	1.9
Interest on money market operations	1.2
Interest on other borrowed money	1.6
Interest on long-term debt	3.1
<i>Net interest income</i>	5.3
<b>Commission and Other Banking Income</b>	<b>4.0</b>
Fees and commissions	2.2
Trading account	0.8
Income from variable income investments, securities and equities	0.6
Other banking income	0.4
<b>Commission and Other Banking Expense</b>	<b>2.7</b>
Fees and commissions	1.9
Other banking expense	0.8
<i>Net banking income</i>	6.6
<b>General Operating Expense</b>	<b>3.2</b>
Salaries, social taxes and employee benefits	2.0
Rent	0.3
Taxes (other than income taxes)	0.4
Administrative expenses	0.5
<b>Depreciation and Amortization</b>	<b>0.6</b>
<i>Operating income before allowances</i>	2.8
Net losses and allowances for loan losses and off-balance sheet items	0.5
Net gains and recoveries of allowances on long-term investments	0.2
Net allocation to the general banking risk reserve	0.2
Amortization of goodwill	0.1
<i>Operating income after allowances</i>	2.2
Exceptional income	0.1
Exceptional expenses	0.1
Firm income taxes	0.7
<i>Net Income (Loss)</i>	1.5

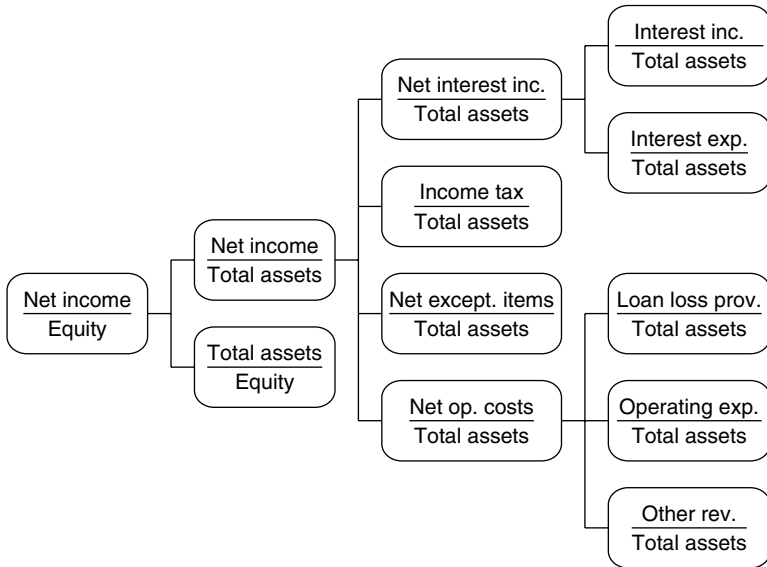

**Fig. 1.3** Du Pont chart for financial entities. A high return on equity is obtained by a strong return on assets and a good equity multiplier. A strong return on assets is obtained by controlling internal costs, a good interest margin and other revenues, e.g., brokerage fees and trading income.

## 1.5 Sources of risk

The core business of banking is to attract funds and to resell or invest. Investing is not without risk. Banks need to take risk to maintain their margins and to fulfill their role in the economy. A bank that takes excessive risk is likely to run into difficulty and may eventually itself fail its obligations and become insolvent.

Risk is the uncertainty or probability that a negative event occurs. In financial terms, a negative event is a loss. Risk management is the broad term to control the risk to the extent possible. Whereas for firms, risk is mainly related to insurance risk types (machine break down, ecological disaster, . . .), bank risk is mainly related with financial risk related to potential losses of financial products [78].

Banks face different elements of risk that require to be identified, understood, measured and managed. The Basel II Capital Accord [63] identifies three main sources of risk: credit risk, market risk and operational risk. These risks are explained in the next sections. Other risks and interaction between risk types are pinpointed in the last section.



## 24 Bank risk management

### 1.5.1 Credit risk

Credit risk is the most obvious risk of a bank by the nature of its activity. In terms of potential losses, it is typically the largest type of risk. The default of a small number of customers may result in a very large loss for the bank [78, 104, 133, 151, 209, 424, 426, 429].

Credit risk is the risk that a borrower defaults and does not honor its obligation to service debt. It can occur when the counterpart is unable to pay or cannot pay on time. There can be many reasons for a default. In most cases, the obligor is in a financially stressed situation and may be facing a bankruptcy procedure. He can also refuse to comply with its debt service obligation, e.g., in the case of a fraud or a legal dispute. Technical defaults result from a misunderstanding because of the flaw in the information system or technology. A credit loss also occurs when the bank invests in debt of a high-quality borrower of which the risk profile has deteriorated. In the case of a liquidation, the price at which the debt is sold on the market is lower than the price at which the debt was bought by the bank, which makes a net loss. In the case of a default, the loss for the bank is not necessarily high. The loss in the case of default depends on the percentage that one can recover from the defaulted counterpart and the total exposure to the counterpart. The recovery depends, a.o., on the presence of collateral and guarantees. A good risk management tries to avoid large exposures on high-risk counterparts.

Credit risk consists of pre-settlement and settlement risk:

**Pre-settlement risk:** Pre-settlement risk is the potential loss due to the counterpart's default during the life of the transaction (loan, bond, derivative product). Pre-settlement risk can exist over long periods, often years, starting from the time it is contracted until settlement. In addition to the counterpart default risk, there is also a risk that the counterpart is prohibited to pay when its country of domiciliation defaults and blocks all foreign payments. This risk is called sovereign transfer risk.

**Settlement risk:** One is exposed to settlement risk because the payment or the exchange of cash flows is not made directly to the counterpart, but via one or multiple banks that may also default at the moment of the exchange. The risk is present as soon as an institution makes the required payment until the offsetting payment is received. The longer the time between the two payments, the higher the risk. Large payments and payments in different time zones and in different currencies have a higher settlement risk. A major example of settlement risk was the failure of Herstatt Bank in Germany in 1974. Some of the money of payments that counterparts

made via the bank was not yet transferred to the recipients when the bank defaulted. One way to reduce settlement risk is netting: by transferring only net amounts, the amount exposed to settlement risk is reduced.

Credit risk is typically represented by means of three factors: default risk, loss risk and exposure risk:

**Default risk (PD):** The default risk is the probability that a default event occurs. This probability is called the probability of default (PD). The probability has values between 0 and 1. There are many definitions of a default event. The most common definition of a default event is a payment delay of at least 3 months. Other definitions may add specific events.

The default risk depends on many factors. Counterparts with a weak financial situation, high debt burden, low and unstable income have a higher default probability. Apart from quantitative factors, qualitative factors like sector information and management quality also allow discriminating between counterparts with high and low default risk. In markets with increased competition, reducing industry margins, and a macroeconomic downturn, the default rates are expected to be higher than on average. Some counterparts have lower risk than that measured on a stand-alone basis: they can receive support from relatives, the mother company or even the state when it is a critical company for the society.

The default risk is assessed internally by means of scoring systems and human expert judgment discussed in Chapters 2, 3 and 4. The continuous default probability is typically represented on an internal rating scale with an ordinal ranking of the risk and discrete, increasing default probabilities. There also exist external rating agencies that provide an independent and external assessment of the default risk for investors in debt and other products.

In most cases, default risk is defined on a counterpart, not on a product. When a counterpart defaults on one loan or obligation, it is likely to default also on its other loans by the contamination principle. In particular asset classes, the contamination principle may not always hold and default risk can also be product specific. In a retail environment, is it not uncommon to observe, *ceteris paribus*, higher default rates on credit cards than on mortgages. Individuals prefer to default selectively on a less critical product than on the mortgage loan to avoid housing difficulties.

In the case of a default, the actual loss depends on the loss given default (LGD) and the exposure at default (EAD). These values are discussed below.

## 26 Bank risk management

**Loss risk (LGD):** The loss risk determines the loss as a fraction of the exposure in the case of default. In the Basel II terminology, this parameter is known as the loss given default (LGD). In the case of no loss, the LGD is equal to zero. When one loses the full exposure amount, the LGD is equal to 100%. A negative LGD indicates a profit (e.g., due to penalty fees and interest rate). In some cases, the LGD can be above 100%, e.g., due to litigation costs and almost zero recovery from the defaulted counterpart. In some textbooks, one also uses the related concept of the recovery rate: the fraction of the total amount that one recovers. Both the loss given default and the recovery rate sum up to one.

The loss given default or recovery rate are not fixed parameters. These values fluctuate from one defaulted product to another. Some counterpart may cure from default and repay all the debt and delayed payments. For others, an agreement between the defaulted debtor and all the creditors may result in a distressed exchange agreement where all involved parties carry part of the loss. In the worst case, the default results in a bankruptcy procedure with high losses and the end of the bank–customer relation. The type of default may have a big impact on the actual loss, but may not be known at the moment of default and certainly not at the moment of the investment. In the case of a default, banks have the right to take legal actions. The timing and type of actions may also impact the actual recovery.

In practice, the LGD values are observed to vary quite a lot and depend upon the type of default and its resolution:

**Cure:** The financial health of the defaulted counterpart is cured shortly after the default event, e.g., because of an additional income or a shareholder intervention. The counterpart continues to fulfil its contractual obligations. There is no significant loss for the bank and the relation with the customer is not impacted.

**Restructuring:** The defaulted counterpart is able to recover from default after a debt restructuring, e.g., debt renegotiations resulting in a longer maturity and partial debt forgiveness. The bank–customer relation is damaged, but is often maintained. The bank accepts a medium loss to avoid higher losses in a liquidation or bankruptcy procedure.

**Liquidation:** The customer's facilities are liquidated, collateral is seized. The relationship with the customer is ended. Liquidation procedures may involve high legal costs and losses are typically high.

It is difficult to predict the resolution type before default. On average, liquidation is expected to occur more for the weakest counterparts for which investors and banks are less eager to reinvest.

In the cases of high default and loss risk, the bank will try to reduce the loss risk by requiring collateral or guarantees. In the case of a default event, the bank will try to recover the outstanding debt and delayed payments from the collateral, guarantees and the counterpart. In contrast to the Bardi and Peruzzi families, the Fugger family negotiated collateral when making loans to kings and governors. Of course, the LGD will depend on the value of the collateral at the time of sale and whether it is legally and practically possible to seize the collateral and sell it. When guarantees are taken, a better protection is obtained with a financially sound guarantor that is not dependent on the obligor's risk.

Banks that invest in more senior debt will have more rights in an eventual default procedure. The seniority depicted in Fig. 1.4 defines the priority rules for the debt holders in the case of default. Senior debt holders have a first pecking right in the case of default, although deviations from the absolute priority rule may occur [338]. Note that collateral is also used to improve the seniority of loans.

Other factors that determine the loss given default have been studied, but depend on the particular case. These include characteristics of the borrower (default risk, amount of debt, income, . . .), characteristics of

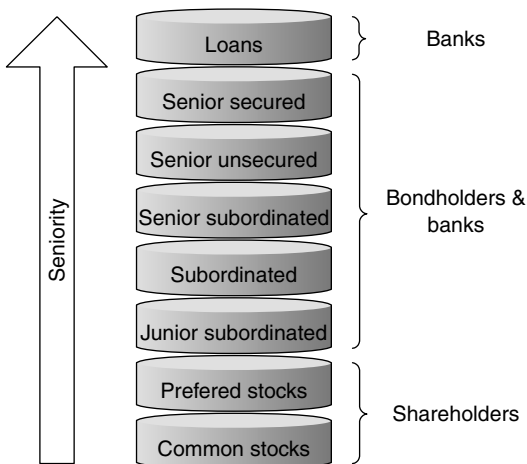

**Fig. 1.4** The debt seniority structure indicates the pecking order of the debt holders in the case of a default. Debt holders with higher priority will generally recover more [432]. Deviations from the general rule have been reported in [338].

## 28 Bank risk management

the product (seniority, collateral, amount), overall characteristics of the economy and the sector and features of the bank–customer relationship.

The LGD is measured on a product basis. It has typically values between 0 and 100% and is either represented in a continuous way or by means of loss grades. Some banks have a separate LGD rating scale on top of the PD rating scale, other banks combine the LGD and PD information on an expected loss ( $EL = PD \times LGD$ ) rating scale. Recently, external rating agencies have also begun to quantify explicitly the loss risk in terms of recovery ratings; complementary to the PD ratings.

**Exposure risk (EAD):** The exposure at the time of default (EAD) may not be known beforehand. For some products like a bond or a straight loan, the amount is a fixed amount. For credit cards or overdraft facilities, the amount varies with the liquidity needs of the borrower. The counterpart can take cash up to a negotiated credit limit. The credit limit bounds the commitment of the bank. Other products have no explicit limit, but each additional drawing needs approval of the bank. The uncertainty on the exact amount at risk at the very moment of a future default is exposure risk. Privately negotiated derivative product contracts also bear exposure risk: if the counterpart of the derivative products defaults during the contract, one is exposed to the net positive value of the replacement cost of the contract. This specific type of risk is called counterpart credit risk.

A typical observation is that financially stressed counterparts have high liquidity needs and tend to use most of the limits. The bank will try to protect itself against such additional drawings by additional clauses in the contract that allow reduced limits or contract renegotiation when specific events occur (e.g., rating downgrade, key ratios drop below threshold limits). These clauses are called covenants or material adverse clauses. Some banks actively manage limits of their most risky counterparts.

Apart from product and covenant properties, one can expect that the exposure risk depends on features of the borrower and on the general state of the economy. The exposure risk is typically expressed in the currency of the product or of the bank (euro, dollar, yen, . . .).

These risk factors also depend on the maturity of the contract. The longer the contract, the higher the uncertainty and the risk. In most applications one measures or expresses the credit risk on a 1-year horizon. The estimation,

modelling and management of the default risk is the most developed. Both LGD and EAD risk received a lot of attention with the new Basel Capital Accord.

For a coherent measurement and management of credit risk, it is necessary to have consistent definitions. The LGD and EAD depend upon the default definition and the LGD is the proportional loss with respect to the EAD. These definitions need to be consistent and coherent to express the risk correctly and to allow comparison and benchmarking of risk levels across different products, business lines, and financial institutions. The Basel II Capital Accord has provided a first step towards a uniform default definition and provides guidelines for LGD and EAD as well: the bank's capital requirements will depend on internally estimated risk levels defined by the Basel II rules.

### 1.5.2 Market risk

Banks take positions on the market for investments or to hedge<sup>4</sup> their positions partially to reduce risk. The market positions via cash or derivative products make the bank vulnerable to large and unexpected adverse market movements. Classical sources of market risk are large movements in equity prices, foreign exchange rates, commodity prices and interest rates [10, 78, 95, 260, 426]:

**Equity risk:** Stock prices are volatile and can exhibit significant fluctuations over time. The equity risk on the portfolio denotes the possible downward price movements of the equity in the portfolio. The main products subject to equity risk are common stocks (voting and non-voting), convertible securities, commitments to buy or sell equities and derivative products.

**Currency risk:** Currency risk arises from price changes of one currency against another. It occurs when making investments in different currencies, especially when making cross-border investments. When a European bank invests in US stocks, the risk arises from equity risks on the stocks, but also from exchange rate risk on the euro/dollar rate. Gold is either seen as a commodity or as a currency. In terms of volatility, it behaves more like a currency. Currency risk is applicable to products and commitments in a foreign currency. The currency risk is perceived lower in fixed-currency

<sup>4</sup> The term hedging refers to taking positions and making arrangements to protect the bank against possible future losses on investments.

### 30 Bank risk management

regimes than floating regimes, but even in such cases devaluations or revaluations that change the parity value of the currencies and changes from fixed to floating regimes represent currency risk.

**Commodity risk:** Commodity risk arises from uncertain future market price changes of commodities. A commodity is a physical product that can be traded on the secondary market. Examples of commodities are agricultural products (grains, cattle), precious metals (silver, copper) and minerals (iron ore, gas, electricity). Prices depend significantly on changes of supply and demand. Commodity markets can be less liquid than interest rate and currency markets, which makes the risk management of commodities more complex.

**Interest rate risk:** The price of some investments depends on the interest rate. Interest rates are expressed as levels or as the difference with respect to a chosen benchmark or reference rate (e.g., government rate, LIBOR or swap rate). The difference (yield spread) can be due to credit quality (credit spread), liquidity (liquidity spread), tax reasons (tax spread) or the maturity (term spread).

A particular example are bonds with a fixed rate for a given time period. When interest rates move up from 4% to 6%, a bond with a coupon of 4% is less interesting and loses value. The loss is higher if the remaining life time or maturity of the bond contract is longer. On the other hand, if the interest rate decreases, bond prices will move up. A standard interest rate risk measure is the duration, which is the cash flow weighted maturity. It indicates how prices change when all interest rates on different maturities move up by 1%. The interest rate risk is specifically important for debt securities and interest-related products in the trading book. Not only the level of the interest rate induces risk, but also changes of interest rates between various products (e.g., firm vs. government bond spreads) and at different maturities.

Interest rate risk is also present on the bank's assets and liabilities, which is often treated separately from the interest rate changes causing price changes. This kind of interest rate risk is discussed in section 1.5.4. In this section, liquidity risk is also discussed, which is often managed in the market risk department (defined in the broad sense).

A standard measure for market risk is value at risk (VaR). This is the maximum loss on the portfolio within a given time horizon with a given small probability. Market risk is typically expressed on a period of days to weeks. In contrast to credit risk with a much lower frequency and that is

typically measured on a yearly basis, market prices are much more frequently available, which allows for a more frequent verification of the risk measure.

For some products like bonds, one may wonder whether they are subject to credit risk or market risk specifications. One makes a split up in the trading book and banking book risk management and rules. The trading book of the bank consists of positions in financial instruments and commodities that are held with the intent of trading or to hedge other elements of the trading book. The trading book is subject to market risk measurement and management standards. The trading book positions are frequently and accurately valued and are actively managed. Trading book positions are held for short-term resale or with the aim to benefit from actual or expected short-term price movements. The banking book typically refers to positions that are held to maturity and is subject to credit risk management rules. The banking book positions correspond to the role of financial intermediary of the bank. A bond held for short-term trading is booked on the trading book; a bond held to maturity on the banking book. Explicit rules exist that define the difference between the trading and banking book to avoid regulatory arbitrage and cherry picking of the most convenient risk measurement approach.

### 1.5.3 Operational risk

Operational risk is defined as the risk of direct or indirect loss resulting from inadequate or failed internal processes, people and systems, or from external events [63]. The definition also includes legal risks resulting from regulatory actions and private settlements. Risks resulting from strategic business decisions and loss or damage of reputation are not included [6, 126, 307, 483]. A classification of operational risk types is provided in Table 1.3 with the Basel II definition [63]:

**Internal fraud:** Losses due to acts of a type intended to commit fraud, misappropriate property or circumvent regulations, the law or company policy, excluding diversity/discrimination events, which involves at least one internal party.

**External fraud:** Losses due to acts of a type intended to defraud, misappropriate property or circumvent the law, by a third party.

**Employment practices and workplace safety:** Losses arising from acts inconsistent with employment, health or safety laws or agreements, from payment of personal injury claims, or from diversity/discrimination events.



## 32 Bank risk management

**Table 1.3** Classification of operational risk event types [63].

Event type category (Level 1)	Categories (Level 2)
Internal fraud	Unauthorized activity Theft and fraud
External fraud	Theft and fraud Systems security
Employment practices and workplace safety	Employee relations Safe environment Diversity and discrimination
Clients, products and business practices	Suitability, disclosure and fiduciary Improper businesses or market practices Products flaws Selection, sponsorship and exposure Advisory activities
Damage to physical assets	Disasters and other events
Business disruption and system failures	Systems
Execution, delivery and process management	Transaction capture, execution and maintenance Monitoring and reporting Customer intake and documentation Client account management Trade counterparts Vendors and suppliers

**Clients, products and business practices:** Losses arising from an unintentional or negligent failure to meet a professional obligation to specific clients (including fiduciary and suitability requirements), or from the nature or design of a product.

**Damage to physical assets:** Losses arising from loss or damage to physical assets from natural disaster or other events.

**Business disruption and system failures:** Losses arising from disruption of business or system failure.

**Execution, delivery and process management:** Losses from failed transaction processing or process management, from relations with trade counterparts and vendors.

Examples of operational risk include a bank robbery, fraud, forgery, technology risk, hacking damage, failure of a major computer system, a human error where an equity sale order of a customer is entered as a buy order, money laundering, model errors, earthquakes . . . An example of failing internal

control measures is the totally unexpected failure of Britain's Barings Bank in February 1995.

Operational risk has a close relation with insurance risk, where the loss probabilities also depend both on the frequency and the severity of the events. The resulting risk depends strongly on the type of activity. Payment and settlement activities are considered as more risky than retail brokerage. Both frequency and severity can be reduced by increased risk management and internal controls. Increased supervision and control will certainly reduce the number of human errors. It is an important incentive of the Basel II Capital Accord to put in place a properly implemented operational risk management system that can manage and contain operational risk events at an early stage. Detailed contracts drawn up by a legal specialist, e.g., may reduce legal risk, while effective fraud detection systems can avoid large losses.

#### 1.5.4 Other types of risk

The bank is also exposed to sources of risk other than credit, market and operational risk. These three types of risk are explicitly treated in the first pillar of the Basel II Capital Accord. Nevertheless, pillar 2 demands that banks have sufficient capital to cover all types of risk, without making explicit which types of risk these can be. Other types of risk include:

**Liquidity risk:** Liquidity risk<sup>5</sup> is the risk that a bank will not be able to efficiently meet both expected and unexpected current and future cash flows and collateral needs without affecting daily operations or the financial condition of the firm [473].

Liquidity problems arise when there are differences at future dates between assets and liabilities in the balance sheet. Such gaps need to be anticipated to ensure the cost of funding at normal cost and to avoid extreme high funding costs by "last minute actions." Consider the example of Fig. 1.5. The positive liquidity gaps (assets–liabilities) need to be funded timely to avoid excessive costs due to emergency funding. Negative gaps involve interest rate risk, which is discussed below. The liquidity risk gap analysis is done for each period in time. It indicates for each period whether there will be large cash outflows that need action.

<sup>5</sup> A different, but related topic is market liquidity risk where banks face the difficulty of changing a position without affecting the market price.

### 34 Bank risk management

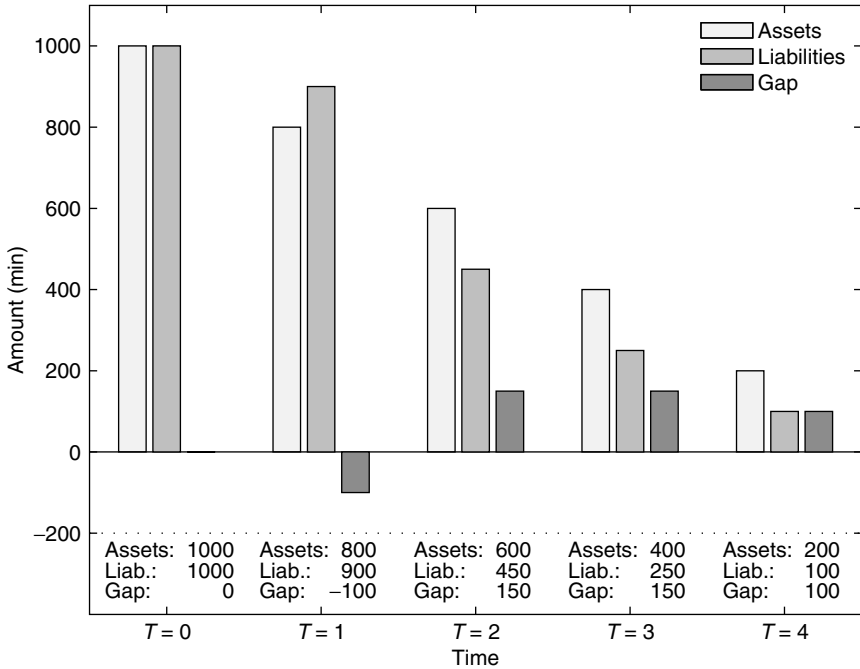

**Fig. 1.5** Liquidity gaps occur when assets and liabilities do not match. Starting with a balanced portfolio of €1000 mln of assets funded by an equal amount of liabilities, the different amortization schemes indicate that at  $T = 2$ , for €600 mln assets, there is only €450 mln liabilities available. Additional funding needs to be foreseen for the liquidity gap of €150 mln at  $T = 2$ .

For assets and liabilities with fixed cash flows, the liquidity risk gap analysis is a rather straightforward exercise for the current assets. More difficult are the projections on future loan productions and funding availabilities. An important issue are products with uncertain cash flows like revolving credits, off-balance sheet credit lines and savings deposits. The latter are especially important for banks with important retail activities due to the size it represents on the balance sheet. These uncertainties make liquidity gap analysis a complex exercise. Loans may grow faster than deposits and banks need to be able to have either sufficient borrowing capacity or sell other, liquid assets. New products can have different characteristics as well: internet depositors may change easily and rapidly large amounts of deposits to other investment types.

Extreme liquidity risk is the risk that the liquidity position is reduced by unforeseen events, like a damage to the bank's reputation, reputation contagion, macroeconomic circumstances, monetary policy changes,

specific products, liquidity contracts, catastrophic events and large failures of counterparts. Reduced liquidity positions can result in liquidity strain and liquidity crisis where increasing funding costs impact profitability and solvency and may eventually lead to default. A main issue in liquidity risk is the risk that the customers will simultaneously demand large amounts of deposits. When this happens on a large scale, it is called a bank run. In order to comply with the demand on the passive side of the balance sheet, banks can be forced to sell large amounts of assets in a very short time, possibly generating a loss. Banks in such circumstances that try to meet demands may incur such losses that default cannot be avoided. Bank runs may become self-reinforcing [79, 145].

The management of liquidity risk is often tailored to the bank's asset structure, with back-up funding plans and stress scenarios to measure the reasonable amount of liquidity the bank needs. Too limited a liquidity may threaten the bank in the short run during stress periods of liquidity. On the other hand, liquid assets are typically less profitable, such that holding too much liquid assets may reduce long-term profitability.

**Interest rate risk:** For the trading book, the interest rate risk is covered in the market risk analysis. For the banking book, this is not the case.<sup>6</sup> The interest rate risk is the risk that changes in the current interest rate level or term structure can have an adverse effect on assets, liabilities, capital, income and expenses. One often refers to the following types of interest rate risk:

**Repricing risk:** Repricing risk occurs from rates moving up or down, resulting in an adverse effect when assets and liabilities with different maturities are matched. For example in Fig. 1.5, the €1000 mln of assets and liabilities have a fixed interest rate payment of 6% and 4% per annum fixed at  $T = 0$ . In the year  $T = 1$ , the interest rate payments liabilities of €900 mln need to be financed on the return of €800 mln and an additional €100 mln. If at this moment, mortgage interest rates have dropped to 3%, the bank makes a net loss on the negative liquidity gap paying 4% to the liabilities and earning 3% on the €100 mln assets.

Repricing risk occurs when maturities are not matched and refinancing at different rates may occur. It is also present when a part of the fixed-rate assets are funded by variable-rate liabilities. In many banks,

<sup>6</sup> Interest rate risk for the banking book is covered in pillar 2 of the Basel II capital accord as explained in section 6.4.5.

short-term deposits are used to fund long-term assets such as mortgage loans. Problems can arise when long-term fixed-rate mortgages have to be refinanced multiple times with variable-rate deposits.

**Basis risk:** Different products are subject to different interest rates (e.g., different benchmarks). Basis risk measures the adverse effect changes in the rates of different products may have: contract rates can be expressed in terms of different reference rates. For example, the interest rate to a customer-tailored specific product can depend on the Libor, while the product is funded by term deposits with respect to the Euribor.

**Yield curve:** Yield curve risk measures the adverse effect that changes in the shape of the yield curve may have on the bank's operation as maturity transformation and profits. Interest rate curves may be subject to a parallel shift, tilts and bends, as illustrated in Fig. 1.6. Traditionally, banks make money by the maturity transformation, taking longer-term positions funded by short-term products; which is interesting when the yield curve has a positive slope. With flattening or even inverted yield curves, income from maturity transformations is reduced and results in losses.

**Optionality:** Recent innovations in financial products include more flexible behaviors of customers, e.g., to draw more cash (call options) or to repay earlier mortgage loans (pre-payment options). Option risk is the

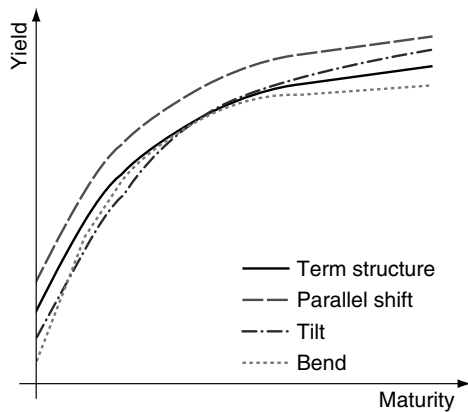

**Fig. 1.6** The term structure of interest rate risk reflects their maturity dependence and has typically an upward trend with longer maturity (full line). The term structure can change in many ways: parallel shifts (dashed line), tilts (dash-dotted line) and bends (dotted line). The term spread is the difference between the long- and short-term rates. In periods of low economic activity, terms spreads typically increase because of smaller capital demand.

risk that the amount or maturity changes because of changing interest rates that trigger the exercise of the options by the customers.

Repricing risk can have a significant impact on the bank's profitability. In the savings and loan crisis of the US in the 1980–90s, banks were receiving mortgage interest rates at 9%, while inflation peaked at 12% and government bonds paid 11% (Table 1.5).

**Reputation risk:** Reputation risk is the financial loss resulting from a potential damage of the bank's reputation. Actions of personnel may have a bad impact on the perception of the bank by its customers, who reduce their business with the bank. Banks may abandon certain actions because they would seem unfair by a vast majority of the public or their customer base. Although the contract could be legally enforced, the bank can opt to negotiate an agreement and take part in the loss to avoid further reputation risk.

**Business risk:** Business risk or entrepreneurial risk may occur from reckless entrepreneurship with high resulting fixed costs exceeding income. Such risks are contained by a good business strategy and adequate risk-return measurement techniques, like, RAROC (risk-adjusted return on capital).

Other, less important types of risk in terms of past impact include political, social, environmental and event risks.

### 1.5.5 Risk interaction

The different types of risk do not occur in isolation. Consider the (hypothetical) example where a European bank ABC makes a one-year loan of \$1000 to a US company DEF for an annual interest rate of 5% that reflect the interest rate for a firm borrower of good credit quality (Fig. 1.7). The current USD/EUR exchange rate is 0.75. The bank purchases \$1000 by paying €750 to the US bank GHI that gives the \$1000 to the company DEF. The contract specifies that company DEF will pay \$1050 one year later to bank ABC via bank GHI. The deal is subject to several risks for bank ABC:

**Credit risk:** The company DEF defaults during the year. This pre-settlement risk is present during the whole year. Also, the US bank GHI can fail just after bank ABC has made the €750 payment and before the money is transferred to company DEF (settlement risk). If the US were to default and restrict money transfers abroad made by its citizens and companies, bank ABC does not get its money back on time (sovereign transfer risk).

### 38 Bank risk management

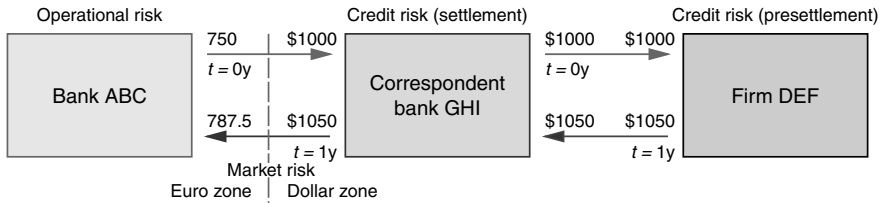

**Fig. 1.7** Illustration of risk-type interaction for a loan from the European bank ABC to the US firm DEF via the correspondent bank GHI. Credit risk is present in terms of pre-settlement risk of firm DEF, in terms of settlement risk of the correspondent bank GHI and in terms of the sovereign risk of the US Wrong transactions (e.g., to correspondent bank GHJ instead of GHI) are operational risks). Exchange rate risk is an important market risk for this type of transaction.

**Market risk:** The main source of market risk is currency risk. When the dollar depreciates from 0.75 to 0.7, the bank receives  $0.7 \times 1050 = \text{€}735$  at the end of the loan and makes a net loss of €15.

**Operational risk:** When the payment of €750 is made to the US bank GHJ instead of GHI. It takes a week before the mistake is noticed. The bank has to make interest payments to bank GHI (approximately €0.75), to compensate the appreciation of the dollar to USD/EUR 0.76 (€10) and to compensate the administration fees. The cost of the operational mistake is roughly €11.

When bank ABC wants to sell the loan during the year, credit risk also occurs when the company ABC deteriorates in credit quality. The bank ABC is forced to sell the loan at lower price due to the increased risk. Interest rate risk occurs when the firm rates increase from 5% to 6%. A legal dispute can occur when the US bank GHI defaults after company DEF has repaid the \$1050 according to the contract, but before this money was transferred to the European bank ABC. When the loan is financed with short-term floating-rate deposits, this contributes to the bank's interest rate and liquidity risk as well.

### 1.6 Risk management

Risk management is primarily concerned with reducing earnings volatility and avoiding large losses. In a proper risk management process, one needs to identify the risk, measure and quantify the risk and develop strategies to manage the risk. The highest concern in risk management are the most risky products. The prior concern for the risk management are those products that can cause the highest losses: high exposures with high default risk. The next

priority are smaller exposures with high risk and large exposures with lower risk. The prioritization of both types is less straightforward. The lowest priorities have low exposures with low risk.

A first impression of risk management can be seen as above. The time and resources allocated to risk management do not directly add to production of new loans or financial assets. However, without risk management functions, it is unlikely that the bank succeeds in achieving its long-term strategy and to remain solvent. In modern banking, risk management is seen as a partner of sales and production. The key risk functions are:

**Risk analysis:** The risk management analyzes the risks of transactions that the bank takes because of its business: credit, market and operational risks. It surveys whether the risks are in line with the risk appetite the banks wants to take. It informs the front office on the risk it takes on transactions and whether the bank is sufficiently rewarded for it.

**Investment and pricing decisions:** The risk management has a key role in the decision making on investment and pricing decisions. Risk is involved in the early stage of the investment process, because it is better to avoid risks up front than to manage high-risk positions afterwards. Risk management often acts as a decision aid. The better the risk management, the better future losses are avoided and the better the risk return. On top of yes/no investment decisions, the risk management also provides a decision aid on a correct pricing with information on minimum margins for the assessed risk level.

**Risk quantification:** Risk management has evolved from a rather qualitative risk ordering towards a quantitative risk environment that assigns numbers to categories of high and low risks. Such a risk quantification requires a good definition of risk measures, data with risk experience and quantitative analysts to model the risk.

**Risk monitoring and reporting:** The risk of existing positions is continuously monitored. Individual transactions may become more risky, especially on longer maturities or because of important changes in the financial, market, or macroeconomic situation. The risk department also monitors the risk position of the bank at the levels of the different portfolio and on the level of the whole bank. It monitors whether the bank's risk profile evolves as expected.

**Strategic advisor:** The risk management is a strategic advisor to indicate to the management of the bank which product types it should take. It surveys whether the investment strategy and global risk-return position are in line



## 40 Bank risk management

with the bank's strategy. Risk is about uncertainty, losses may impact the bank's earnings and erode its capital. Risk management is necessary to assess the possible impact changing economic and/or market conditions on the bank and how to mitigate risks that are too high.

**Solvency:** Bank capital is required to absorb an unexpected losses. When losses exceeds expectations, the capital buffer serves to absorb an unexpected loss amount. When the capital buffer is insufficient, the bank becomes insolvent. Solvency risk depends on the possibility of unexpected high losses and the capital level. For a given portfolio, the capital level needs to be determined to obtain a sufficiently low solvency risk for the bank, that is determined by the management. Regulation recently evolved to more risk-sensitive capital rules. The new Basel II accord defines rules in which a higher regulatory capital buffer is required for riskier positions.

Recent banking regulation encourages and gives incentives to adequate internal risk management processes. Efficient banks find a good balance for risk management spending.

### 1.6.1 Risk management process

The main steps in a risk management process are (Fig. 1.8):

**Identification:** Within a defined perimeter and scope of the risk management process, one identifies all potential risks. The identification can start by analyzing sources of potential risk (e.g., lower housing prices may result in lower recoveries and higher losses on a mortgage loan) or identifying threats (e.g., which factors would result in higher losses on a mortgage loan). The identification of all the risks requires a good knowledge of the financial products. A main risk is the lack of identification ability in the organization, e.g., due to insufficient competencies.

**Measurement:** Given the identified sources of risk, one needs to quantify the risk. For credit risk, this means, e.g., that one needs to determine the actual default probability and how much a change of the risk drivers (e.g., profitability of a firm) impacts the default probability. How much will the loss given default increase if housing prices reduce by 10%? Risk measurement requires thorough statistical analysis of past events. When in case past events are only available to a limited extent, one applies theoretical models and expert knowledge to quantify the risk.

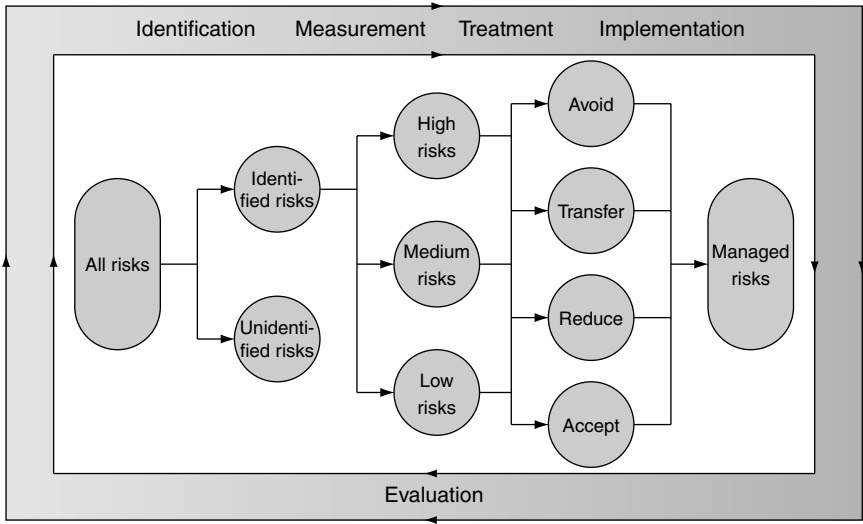

**Fig. 1.8** Different steps of a continuous risk management process: identification, measurement, treatment and implementation. The whole cycle is continuously evaluated to detect new risks and improve existing systems.

**Treatment:** Risk can be treated via one of the following four ways [152]:

**Risk avoidance:** A simple way to treat risk is to avoid risk. This implies that one does not invest in products that are too risky or for which the risk is not well enough understood. Avoidance does not mean that one avoids all risk, a strategy may consist of selecting the good counterparts and not investing in counterparts with too high default, loss or exposure risk. Alternatively, one may decide to invest only small proportions in such counterparts; one limits the exposure on risky investments. This reduces the concentration risk.

**Risk reduction:** Risk reduction or mitigation implies that one takes a part of the risk, but not the full part of it. For high-risk counterparts, one may require collateral that the bank can sell in the case of a default. The value of the sold collateral reduces the actual and hence the risk for the bank. One may also ask guarantees from a family. Risk reduction may not always be feasible.

**Risk acceptance:** One accepts or retains the risk that one has to take as part of the business strategy. Risk acceptance is typically applied for low-risk assets. Risk is more easily accepted when it is well diversified: investments are made in various sectors and countries, where it is

## 42 Bank risk management

unlikely that high losses will occur simultaneously in all sectors and in all countries.

**Risk transfer:** One transfers the risk to another bank, insurance or company. Insurance companies, called financial guarantors, exist that provide guarantees to credit risk. A specific type of credit derivatives, a.o., credit default swaps are a type of option contract in which the buyer of the contract is reimbursed in the case of the default of the underlying counterpart.

Risk management strategies may be composed of multiple categories.

**Implementation:** Once the risk management strategy has been defined, it is implemented. People, statistical models and IT infrastructure evaluate the risk of existing and new investments. Guidelines for the risk treatment define in which counterparts does one invest and in which one does not; which exposure limits are used for the most risky products; whether collateral for specific loans is mandatory or whether one buys protection from a financial guarantor. The risks of the bank are continuously reported and monitored. The implementation is supervised by senior management.

**Evaluation:** The effectiveness of the risk management strategy is evaluated frequently. One verifies whether the resulting risk taking remains in line with the strategy and applies corrections where necessary. This involves evaluation of the relevant risk drivers, the measurement process is evaluated, a.o., in backtesting procedures, the result of the risk treatment plans and the actual implementation.

### 1.6.2 Credit risk management

Credit risk is managed in various ways. The most important techniques to manage credit risk are:

**Selection:** A good credit risk management starts with a good selection of the counterparts and products. Good risk assessment models and qualified credit officers are key requirements for a good selection strategy. Important credit decisions are made at credit committees. For counterparts with a higher default risk, more collateral is asked for to reduce recovery risk. Recovery risk is also reduced by requiring more stringent covenants, e.g., on asset sales. A good selection strategy also implies a good pricing of the products in line with the estimated risk.

**Limitation:** Limitation restricts the exposure of the bank to a given counterpart, it avoids the situation that one loss or a limited number of losses endanger the bank's solvency. The total amount of exposure to riskier counterparts is more restricted by a system of credit limits. The limit setting of the bank determines how much credit a counterpart with a given risk profile can take.

**Diversification:** The allocation process of banks will provide a good diversification of the risk across various borrowers of different types, industry sectors and geographies. Diversification strategies spread the credit risk in order to avoid a concentration on credit risk problems. Diversification is easier for large and international banks.

**Credit enhancement:** When a bank observes it is too exposed to a certain category of counterparts, it can buy credit protection in the form of guarantees from financial guarantors or via credit derivative products. By the protection, the credit quality of the guaranteed assets is enhanced. This is also known as credit risk mitigation.

These principles are translated in the daily organization by written procedures and policies that determine how counterparts are selected, upto which risk exposure and risk profile loans are quasiautomatically granted and above which level a human expert evaluation is required. Larger or more complex files are typically discussed at a credit committee where senior lender and risk officers discuss the possible transactions. Credits that deteriorate and become too weak are put on a watchlist, are closely monitored and remedial actions taken when it seems necessary (e.g., protection purchase). The current risk position of the bank is communicated regularly to the senior management and business lines, which may adjust the current strategy.

The risk management strategy is defined as part of the general strategy. In particular, the credit risk management needs to foster a climate for good banking where prices are in line with the risks taken. A strong strategic credit risk management avoids important pitfalls like credit concentrations, lack of credit discipline, aggressive underwriting to high-risk counterparts and products at inadequate prices. Four types of credit culture have been identified in [351]:

**Value driven:** The value-driven strategy adheres to long-term and consistent performance and requires a strong credit organization defined by the long-term profit plan. The success of this strategy depends on the balance that needs to be found between credit quality and revenue generation.

## 44 Bank risk management

**Immediate-performance driven:** The immediate-performance-driven strategy defines current earnings to sustain a high stock price as the main priority. Profit generation is defined by the annual profit plan. The credit culture is similar to the value driven, with emphasis on strong credit quality, but for which deviation can be omitted during periods of low credit demand.

**Production driven:** For this strategy, market share and volume growth are the highest priority, which is motivated by the ambition to become or to remain a large player on the market. Front office lenders are demanded to produce new loans and may experience difficulties with credit risk loan approvers, because of low credit quality and non-adequate pricing. Loan approvers see their influence limited because of the conflicting interests of value and asset quality. Success depends on the strength of the credit risk management to control the approval process and to keep sufficient asset quality in the growing portfolio.

**Unfocused:** In the unfocused strategy, priorities may change frequently to time-varying current priorities. This strategy may result from a reactive management, but also from a lack of a clear long-term vision. It often causes confusion for front-office lenders and risk officers. Portfolio asset quality is only guaranteed when the credit risk department has strong policies and risk systems.

The optimal risk strategy is the one that is in line with the business strategy. It is not the one that minimizes losses, but the one that provides a good credit quality in line with the business objectives. A good credit culture has strong policies and credit standards, while new markets are selected to conform to the existing culture. The effectiveness of the credit risk management is verified by internal risk control and audit that monitor credit discipline, loan policies, approval policies, facility risk exposure (PD, LGD, EAD) and portfolio level risk. The credit culture is supported by the top management and by a strong credit risk management.

### 1.6.3 Market risk management

The market risk management starts with the identification of the risk drivers that explain the market value of a financial security. Market prices can move because of common, systematic factors or because of individual factors. For example, the stock price of a company depends on the general market evolution, e.g., measured by the country stock index and the sector stock

index, and on the company-specific performance, e.g., past and expected future profitability. The general market evolution is a systematic factor, that will also influence the stock price of other companies. The company-specific elements are called idiosyncratic noise and cancel out on a global, diversified portfolio.

The standard risk measure for market risk transactions is the value-at-risk (VaR). It defines the potential loss on a transaction or on a product that is exceeded only in a fraction (e.g., 1%) of the total number of events. The 99th VaR indicates a loss limit that is only exceeded in one event out of a hundred. Other risk measures are defined in Chapter 5. The VaR measures are used to measure the risk on individual returns and on global portfolios. It is measured on a historical basis, by analytical formulas or by Monte Carlo simulation making use of advanced models. The pricing models used in these models are specific for the risk type and on the product type. Often, the price sensitivity of a product or a portfolio to a risk driver is used to give a key indication of the risk sensitivity.

The market risk is often defined on a time horizon of 1, 5 or 10 business days, which are natural time horizons for the measurement of this risk type. Recently, different risk types are combined at the global bank level and the market risk levels are also technically scaled to longer time horizons (up to one year) to obtain an aggregated risk measure. Note that such scalings are mainly used for economic capital measures, while market risk practitioners continue to use the VaR levels on the relevant short-term horizons.

Market risk is managed by similar principles as credit risk. The portfolio is built up by a good selection of products by which one expects to make a profit in return for an acceptable risk level. Market portfolio positions may also be taken just to reduce risk.

A simple, but effective way to reduce the risk is to limit the possible losses on individual transactions, subportfolios and portfolio levels by defining limits, e.g., based upon VaR. Such limits constrain the amount at risk to a single product or to a group of related products and result in a diversified trading portfolio. The limits are defined by the management in line with the expected business developments and the risk appetite.

Hedging means that one takes market positions that respond in an opposite way to changes in the systematic risk factors. When one buys or goes long the stock A and at the same time, sells without owning or shorts the stock B that is part of the same stock index as A; the net risk of both positions is lower than the risk of the individual positions due to a change in the stock index. If the stock index moves up, one gains on the long position in A and

## 46 Bank risk management

loses on the short position in B. Hedging is used to reduce market risks and is especially interesting when it is difficult to reduce a given market position, e.g., in company A. The reduction in market risk by purchasing B provides an interesting alternative. An attention point for hedging is that hedges may not be complete and the risk may not be reduced completely.

Derivative products are used to transfer the risk of high losses and keep the risk to an acceptable level. Stop loss limits define maximum loss limits after which positions are closed. The current loss in market value is realized and becomes a cash loss. One loses the opportunity of a recovery in market value and a lower cash loss, but avoids any further losses.

### 1.6.4 Operational risk management

Operational risk management aims at reducing the number of events and limiting the losses on big events. It consists of assessment and loss management. In the assessment process, one identifies the risks and verifies whether these are acceptable for the organization:

**Self-assessment:** For each business entity, operational risk representatives and managers identify its key risk types and measure their importance (frequency and severity), e.g., by means of scorecards. In a retail environment, credit card fraud may occur frequently, but the severity is limited. The outcome of the global exercise is represented on the bank's global operational risk-type definitions. The results of the self-assessment exercise are reported on the level of the global bank and its main entities to detect the most important risk types.

**Gap analysis:** It is verified whether the risks, identified in the self-assessment exercise, are acceptable for the organization and where the most important differences are between the current situation and the bank's operational risk appetite. When the operational risk is too high, remedial actions are taken like the purchase of insurance on rare, but high-loss event types, or changes in internal policies and procedures to reduce event numbers and loss severity (e.g., additional control to reduce internal fraud on large ticket business).

**Key risk indicators:** For the accepted and reduced risk types, each business defines a number of targets on operational risk events or losses that are key to monitor. These key risk indicators concern events that one wants to monitor closely or that one aims to reduce with new actions. In a retail environment, e.g., a key risk indicator is the number and amount of credit

card frauds. An increasing number of frauds may indicate a new fraud mechanism that is not captured by the current controls.

The second part of the operational risk management cycle is the loss evaluation that consists of

**Monitoring of key risk indicators:** The level of the key risk indicators is regularly monitored to detect evolutions in the risk profile.

**Data collection:** Both the number of events and the loss severity per event are stored in internal databases with details on the circumstances, the business unit, the legal entity, main causes, etc. To reduce the number of events, one typically stores only those events above a certain materiality threshold.

**Loss event reporting and analysis:** Based upon internally and externally collected loss event data, a statistical analysis of the frequency and severity distribution is performed on the different risk types. Where possible, this is done on cells of individual event type and business type. A global risk distribution on all event types is calculated. The results are compared with the expected outcome and are reported to the senior management.

The operational risk management circle is visualized in Fig. 1.9. Because explicit operational risk management is a rather new concept in the context of Basel II regulation, communication on operational risk in the organization is a key issue. Compared to credit and market risk, operational risk also involves an important component of active risk management, like internal controls, especially to avoid large losses that cannot be easily offset by capital as it would just require too much capital.

## 1.6.5 Management of other risks

The ALM risk management techniques concerning liquidity and banking book interest rate risk management are discussed. The risk management of other risk types (e.g., reputation risk) is developing.

### 1.6.5.1 Liquidity risk management

For simple products in the current balance sheet, it is straightforward to calculate the future gaps to detect future liquidity problems. For new production, assumptions on future evolutions need to be made. Seasonal and even cyclical cash in and out flows are still relatively easy to predict, but longer-term



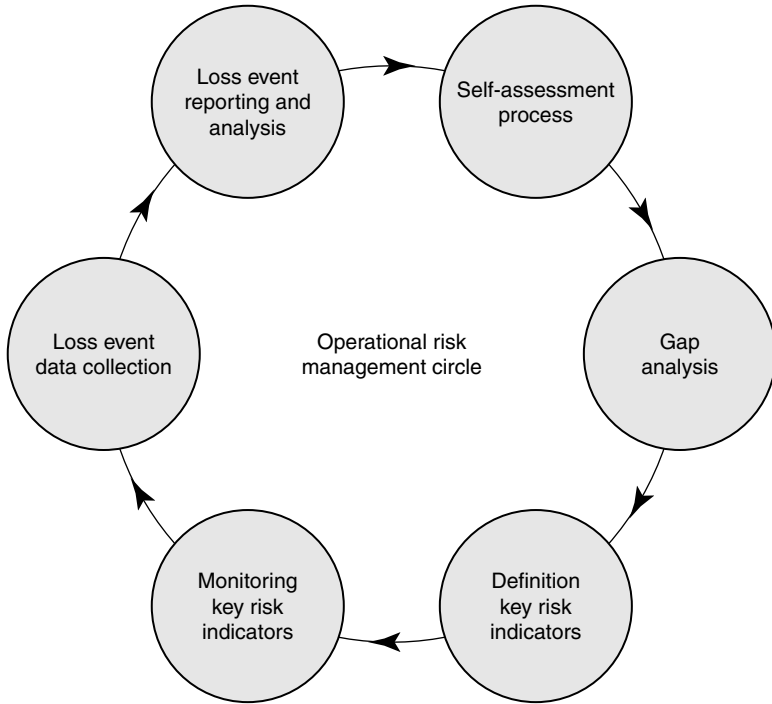

**Fig. 1.9** The operational risk management process is a circle of continuous improvement that is initiated with a self-assessment. Based on the gap analysis, risk treatments are defined and key risk indicators are defined to monitoring of the risk management. Based upon the statistical evaluation, the assessment and treatment are adjusted.

predictions are more difficult to make. Advanced banks use scenario analysis to determine the future liquidity needs of the bank. In these scenarios, models dependent on macroeconomic variables like economy activity, consumption, interest rate and inflation are used to predict customer behavior. These scenario analyses allow the bank to measure its risks and take measures to avoid future liquidity problems.

Banks will hold a liquidity buffer having an excess of short-term assets compared to short-term debt. It serves as a cushion against net outflow of funds, to have a sufficient source of funds to make new investments, to buffer possible unexpected delayed payments from customers and to have funds when contingent liabilities fall due. The amount of liquidity needed by the bank depends on its overall strategy, the expected seasonal fund in- and outflows, its access to liquidity markets (strong banks may have easier access), expected interest rate evolution and the cost of the various liquidity

sources. Banks define strategic contingency funding plans to cope with these difficulties.

Liquidity risk is managed via multiple mechanisms, including liquidity pools, multiple funding sources and the sale of assets, e.g., via structured products or securitization. Effective communication with investors, depositors, banks, rating agencies and other stakeholders is believed to be a key element to reassure funding in the case of liquidity strain [473].

### 1.6.5.2 Interest rate risk management

Classical techniques for interest rate risk measurement are gap and duration analysis:

**Interest rate gap analysis:** The interest rate gap is the difference between the values of variable rate assets and liabilities at a given time projection:

$$\text{Interest rate gap} = (\text{Var. rate assets} - \text{Var. rate liabilities}).$$

When the gap is constant over time and the variable interest rate assets are sensitive to a common interest rate  $i$ , the change in interest margin ( $\Delta\text{IM}$ ) to a change in interest rate  $\Delta i$  is equal to

$$\Delta\text{IM} = (\text{Interest rate gap}) \times \Delta i.$$

The gap indicates no risk when it is zero. When the bank has more interest-rate-sensitive assets than interest-rate-sensitive liabilities, the bank's interest rate margin increases when the interest rates rise and decreases when interest rates fall.

Banks will try to have a positive gap to increase profitability when interest rates are expected to fall, and try to have a negative gap otherwise. The gap measure is typically limited to  $\pm 10\%$  of the balance sheet, a higher value is called a tactical gap.

Figure 1.10 illustrates the gap measurement. A gap of 10% of the balance sheet is observed. When interest rates rise, the bank's asset income will increase more than its funding cost on the liabilities, because these represent only 40% of the balance sheet compared to 50% for the variable-rate assets. Note that there is a link with liquidity gaps: a liquidity gap represents a repricing risk at an uncertain rate that is included in the variable assets or liabilities part.

**Duration analysis:** Duration measures the sensitivity of the value of a financial asset to a change in interest rates. The modified duration of an asset is

## 50 Bank risk management

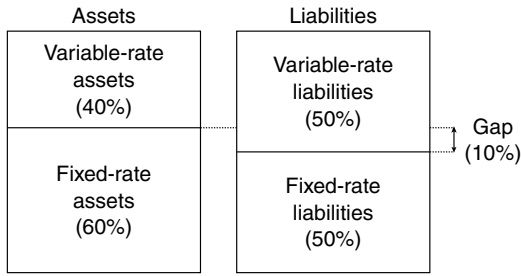

**Fig. 1.10** Interest rate gap analysis at a certain time period. The interest rate gap is equal to the difference between variable-rate assets (50%) and liabilities (40%). The gap is 10% of the balance sheet.

defined as the relative sensitivity of the price  $P$  to changes in the interest yield  $y$

$$\text{modified duration} = -\frac{1}{P} \frac{\partial P}{\partial y}. \quad (1.1)$$

Because prices tend to decrease ( $\partial P < 0$ ) with increasing yields ( $\partial y > 0$ ), a negative sign is introduced to have a positive duration number. The price change  $\Delta P$  of the products in the balance sheet to a yield  $\Delta y$  is equal to

$$\Delta P \approx -\text{modified duration} \times P \times \Delta y$$

for small changes  $\Delta y$ . There exist a wide number of duration measures, like the dollar duration that is the product of the modified duration and the price. It allows the absolute price sensitivity to be expressed as a product of the duration and yield change

$$\Delta P \approx -\text{dollar duration} \times \Delta y.$$

When duration measures are over a whole portfolio to indicate the portfolio price sensitivity, the change in economic value of the portfolio is obtained. With some simplifications, it indicates the bank's risk to a parallel shift in the interest rate curve.

Gap analysis and duration were the first measures for interest rate risk. With a larger variety and more complex products, advanced measurement techniques have been applied. Note that the assumption of a sensitivity to the same interest rate curve is not realistic and does not take into account the basis risk and optionality.

More advanced interest risk tools are nowadays used that deal with uncertain cash flows, a.o., from products with embedded options. Income

simulation and scenario analysis are useful tools to project the bank's balance-sheet performance under each scenario.

Each of these techniques measures the risk to interest rate changes. Risk management aims to reduce the volatility of the bank's interest margin to an acceptable level according to a risk-return trade-off. The risk reduction is achieved by a proper balance sheet management. The interest-rate gap is managed by defining targets for volumes of different product types and by defining interest-rate limits. A diversification is made between fixed and variable rate such that the interest-rate risk is sufficiently hedged.

The interest-rate and liquidity risks are further reduced by additional hedging programs and by anticipating funding needs and locking in funding timely to reduce variable liabilities. Asset liability management (ALM) is concerned with the proper management of the balance sheet with respect to interest-rate risk and liquidity risk. It became important in the 1970s when interest rates became more volatile. The important task of ALM is the management of the balance sheet with the aim of income volatility reduction to an acceptable level [78, 139, 345, 448, 482, 486].

### 1.6.6 Interaction with bank management

The bank management needs to find a good trade-off between the different risk types and to have a good strategy to maintain and/or improve the profitability. The bank management needs to balance between performance risk, financial risk, and business risk (Fig. 1.11):

**Business risk:** Business risk is the risk that the bank's strategy and business model fail or exhibit unacceptable risks, e.g., when the loan production declines, or the loan acceptance strategy focuses on growth by also accepting also higher-risk loans, while the prices are not adjusted to absorb future losses, or when the business mix is very concentrated on a particular sector and does not allow for diversification strategies. Business risk is sometimes also referred to as operation risk.

**Performance risk:** Performance risk is the risk that the overall profitability of the bank becomes insufficient, e.g., because of too low margins asked for riskier counterparts, because of insufficient income diversification and resulting high income volatility, or because of failing expense control.

**Financial risk:** Financial risk entails the previous risks. Credit, market, operational, interest rate and liquidity risk are the main elements of financial risk. Good risk management and sufficient capitalization are required to control financial risk.

## 52 Bank risk management

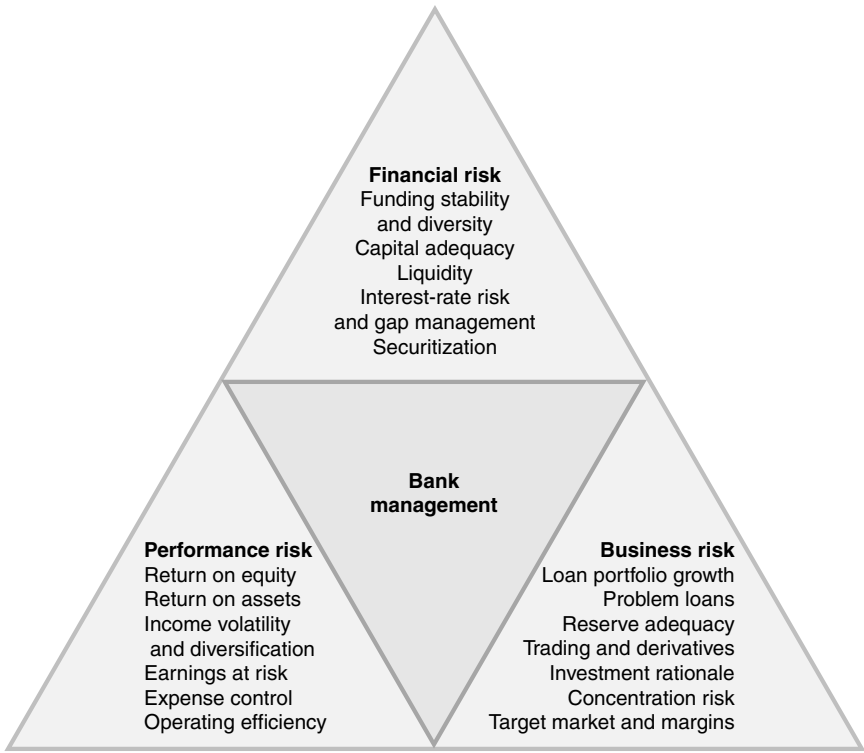

**Fig. 1.11** The role of the bank management is to find a good trade-off between business, performance and financial risk. The target customers need to be well selected to have a good return for the risk taken.

The priorities of the organization need to align profitability, risk profile and asset quality, and growth and market share as set by the business plan.

The implementation of an effective risk management process is a key requirement for a modern bank. The risk management process itself is supervised by internal risk control, validation and audit departments as well as external auditors and banking supervisors.

### 1.7 Regulation

In most countries, the banking and financial services industry in general are regulated. Banks need permission to trade. Regulatory and supervisory authorities grant to banks the permission for the main banking services. In order to receive such permissions, banks need to be sufficiently safe for customers and the economy as a whole. The supervisory authorities grant

permissions but keep on monitoring the banks and can intervene and even withdraw the bank's permission to trade.

Bank regulation aims to reduce the default risk of banks and to protect the savings of the depositors against excessive risk taking of the bank. While in the nineteenth century, banks had very high equity to loans ratios of about 50%, this ratio has decreased steadily. Since the end of the Bretton Woods agreements, the bank's total asset grew continuously because a higher profitability can be obtained by a higher equity multiplier (total assets/equity) or leverage (total debt/equity). The banking system was weakened. A first supervisory action put target maximum leverage levels between 30 and 33. For one Euro, Dollar or Yen, one can lend 30. Large banks were forced to reduce their growth or increase capital.

Asset size is not a very reliable measure of risk: mortgage loans are generally less risky than loans to speculative grade companies during a recession. Capital was not aligned with risk until the first Basel Accord of 1988. Both for industrial firms and banks, capital is generally considered as a buffer to absorb losses and protect creditors. It was felt necessary to introduce international capital standards to align the bank's capital with the risks it is exposed to. The banking regulation aimed to protect the banks creditors and their saving deposits in particular as well as the bank guarantors, like the national deposit insurance funds. At the same time, an international level playing field was created with the same rules for all the international banks.

### 1.7.1 Role of regulation

Bank regulation may seem odd. Banks are commercial organizations that make profit by offering financial services. Banks are subject to specific capital regulation, while industrial firms are not. Regulation may introduce friction, disturb the market equilibrium and reduce growth opportunities by the additional constraints [176]. Regulation is acceptable in cases of monopolies, to protect public goods or when markets are imperfect, e.g., because of imperfect information. Banking regulation is generally considered as an exception to a free, deregulated market because of the following reasons:

**Deposit protection:** The first goal of regulation is to protect the deposits of the small creditors. These creditors are mostly not fully informed about the solvency of the bank and the risk of their deposits or the time/cost for this risk analysis would be too high given their lack of expertise. Because

## 54 Bank risk management

creditors have not sufficient information to adequately monitor their bank, regulation is necessary [142]. In some countries, there is full or limited deposit insurance. Bank regulation reduces the insurance costs and moral hazard problems. A discussion on the effectiveness of deposit insurance is given in [138].

**Avoidance of systemic risk:** Banks have significant exposures to other banks. When one bank collapses, the shock may contaminate other banks. When some banks are heavily impacted, the shock is amplified and the domino effect may eventually impact the whole financial sector. The resulting total macroeconomic cost of the financial crises and the bail out of the failed banks impacts the gross domestic product of several countries [258, 302]. A recent example of regulatory intervention happened after the near-collapse of the Long Term Capital Management hedge fund following the 1998 Russian bond default. Preventive action is not always guaranteed, no intervention was observed with the failure of BCCI.

**Protection of money:** Money reflects primarily the currency and also its distribution, payment and settlement systems. A financial crises will impact these elements and impact the public good that money is [93, 257].

**Financial efficiency:** The collapse of one or more banks will reduce the efficiency of the financial functioning in the local economy. Other banks may technically and financially not be able to take over immediately the role and functions of the failed bank(s). The reduced financial efficiency can result locally in reduced industrial investments [392].

The reader may consult [297, 434, 510] for discussions on how to implement banking regulation. In general, regulation is implemented in most countries. Care is taken to avoid too much conflict between regulation and competition.

### 1.7.2 Basel Committee on Banking Supervision

The Bank for International Settlements<sup>7</sup> (BIS) is an international organization that serves as a bank for central banks and promotes international monetary and financial co-operation. The BIS was established on 17 May 1930 and is based in the Swiss town Basel. It is a place where central

<sup>7</sup> More information on the BIS, the Basel Committee on Banking Supervision and the Basel Capital Accords is available from the website [www.bis.org](http://www.bis.org).

bankers co-operate and it assists the pursuit of global monetary and financial stability by

1. Providing emergency financial assistance to central banks in the case of need. Examples include BIS support credits to German and Austrian central banks during the financial crises 1931–1933, to the pound sterling and French franc in the 1960s, to IMF-led stabilization programs for Mexico 1982 and Brazil 1988.
2. Providing expert guidance to national central banks and supervisory agencies for especially international bank regulation and supervision. Well-known examples include the Basel Capital Accords.

The need for international banking supervision became apparent in the 1970s with the growth of international financial markets and cross-border money flows. Before, banks were basically regulated at national levels by national central banks, while the growing international activities escaped the main supervisory focus. The Basel Committee on Banking Supervision<sup>8</sup> (BCBS) was founded in 1974 by the board of governors of the G10 central banks in the aftermath of several financial crises and bank failures, like the 1974 collapses of Bankhaus Herstatt in Germany and of the Franklin National Bank in the United States. The first meeting took place in February 1975. Meetings have been held regularly three or four times a year. Nowadays, the BCBS counts 13 member countries. Each country is represented by its central bank and by the supervisory authority in countries where this is not the central bank. The current members are listed in Table 1.4. The BCBS was consecutively chaired by Sir Blunden (1974–1977), Mr Cooke (1977–1988), Mr Muller (1988–1991), Mr Corrigan (1991–1993), Dr Padoa-Schioppa (1993–1997), Mr de Swaan (1997–1998), Mr McDonough (1998–2003), Mr Caruana (2003–2006). Since June 2006, the chairman has been Mr Wellink, President of the Netherlands Bank [65].

The initial goal was to reduce gaps in the nationally oriented supervisory net by international co-operation between supervisors. Its scope was extended to improve worldwide supervisory understanding and the quality of banking supervision. This is accomplished via information exchange on national supervisory arrangements, via improved effectiveness

<sup>8</sup> The BCBS is not the only committee that helps to promote the monetary and financial stability. Other BIS-based committees are the Committee on the Global Financial System (1971), the Committee on Payment and Settlement Systems (1990), the Markets Committee (1964) and the Financial Stability Institute (1999).



## 56 Bank risk management

**Table 1.4** Member countries and institutions of the Basel Committee on Banking Supervision.

Country	Institution
Belgium	National Bank of Belgium Banking, Finance and Insurance Commission (CBFA)
Canada	Bank of Canada Office of the Superintendent of Financial Institutions
France	Banking Commission, Bank of France
Germany	Deutsche Bundesbank German Financial Supervisory Authority (BAFin)
Italy	Bank of Italy
Japan	Bank of Japan Financial Services Agency
Luxembourg	Surveillance Commission for the Financial Sector
Netherlands	The Netherlands Bank
Spain	Bank of Spain
Sweden	Sveriges Riksbank Finansinspektionen
Switzerland	Swiss National Bank Swiss Federal Banking Commission
United Kingdom	Bank of England Financial Services Authority
United States	Board of Governors of the Federal Reserve System Federal Reserve Bank of New York Office of the Comptroller of the Currency Federal Deposit Insurance Corporation

of supervision of international banking businesses and via the definition of minimum supervisory standards. The BCBS sets up these guidelines without formal supranational authority. The guidelines from the BCBS are transmitted into local legislation via the responsible bodies in the different G10 countries and other countries that follow. Many supervisory guidance documents are available from the BIS website ([www.bis.org](http://www.bis.org)).

The ongoing erosion of capital adequacy and increased exposure to emerging markets and highly indebted countries, have made capital adequacy a key attention point since the 1980s. The consensus grew that capital should be in line with the on- and off-balance sheet exposure weighted by the risk profile; and that a multinational accord was necessary to remove differences in local capital requirements as a course of competitive inequality. The Basel

I guidelines released to banks in 1988 defined a minimum capital level of 8% of the risk-weighted amount of assets. This capital ratio became active in 1992. The Basel I Capital Accord or 1988 Capital Accord was approved by the G10 governors and was progressively implemented in almost all countries with internationally active banks. The capital accord was amended for bilateral netting of derivative products in 1995 and to include market risk in 1996. It imposed capital requirements from open positions on foreign exchange, traded debt securities, equities, commodities and options. The amendment followed 2 consultative processes and became effective at the end of 1997. To keep the supervision standard up to date with ongoing financial innovation, the BCBS issued in June 1999 a proposal to revise the 1988 Capital Accord. After several consultations, the new framework was released in 2004 and extended with the treatment of trading books in June 2006. The 2006 Capital Accord revision is known as the Basel II Capital Accord [63], fully known as the

*International Convergence of Capital Measurement and Capital Standards, A Revised Framework, Comprehensive Version.*

The ICCMCS 2006 defines minimal capital requirements for credit, market and operational risk of increasing complexity and bank responsibility (pillar 1); guidelines for external supervision and internal assessment processes (pillar 2); and effective use of disclosure to strengthen market discipline (Pillar 3). The major revision of the Basel I Capital Accord concerns the refined credit risk measurement with increased responsibilities for the internal bank risk measurement and the introduction of explicit operational risk capital requirements. The Basel II Capital Accord is being implemented via domestic rule-making and approval processes. The Commission of the European Union issued a proposed Directive in 2004 that was finalized in 2005. The Directive is implemented in its member countries by the local legislation and supervision authorities.

The BCBS has organized its work under 6 main subcommittees:

**Accord Implementation Group:** The AIG provides a forum to exchange information and discuss the practical implementation of Basel II. It promotes consistency on the implementation. There are 3 subgroups focusing on credit, operational and market risk issues. The validation subgroup is concerned with challenges on the validation of internal rating systems for credit risk measurement. The operational risk subgroup is primarily concerned with issues on the bank's implementations of the advanced

measurement approach. The trading book subgroup addresses issues on the application of Basel II to trading activities and the treatment of double default effects. The 3 subgroups of the AIG focus on the challenges coming from new measurement techniques and regulation.

**Capital Task Force:** The CTF is considered the primary custodian of the Basel II framework. It assists the BCBS on interpretations of the capital framework. Two working groups report to the CTF. The working group on overall capital and qualitative impact studies (QIS) provides information on the actual calibration of the Basel II risk weight parameters. It conducts quantitative impact studies (QIS) where banks are asked to measure the impact of the new capital risk weights on their balance sheets. The impact studies learn whether the capital in the banking industry will increase or decrease as a result of the new capital accord. The formulae to calculate the capital have been adjusted during the consultation process before the final capital accord of 2004. The risk management and modelling group is the BCBS' contact point for evolutions on credit risk modelling techniques and provides recommendations on the management and modelling of credit risk for issues related to the supervisory review process and market discipline.

**Accounting Task Force:** The ATF is concerned with emerging issues on accounting and auditing. It evaluates and addresses especially those issues that may have an impact on the financial strength and safety of financial organizations. The ATF develops prudential reporting guidance and takes an active role in the development of international accounting and auditing standards. The ATF has six working groups. The IAS 39 subgroup is concerned with the International Accounting Standard 39 on the recognition and measurement of financial instruments, a key accounting rule for banks and supervisors. The loan accounting subgroup has drafted the supervisory guidance on accounting for loans and loss provisions in credit risk measurement and will ensure its proper implementation in relation with the impairment principles of the IAS 39. The conceptual issues subgroup focuses on the works of the International Accounting Standards Board (IASB) and the Financial Accounting Standards Board (FASB) on and the Financial Accounting Standards Board (FASB) on consistent approaches for measurement selection objectives for financial statement items. The audit subgroup focuses on the work of the International Auditing and Assurance Standards Board (IAASB) that sets, a.o., auditing standards. The financial instruments disclosure subgroup and performance subgroup are the two other subgroups on the corresponding accounting issues.

The ATF is also actively involved in the monitoring group in which the BCBS, the International Organization of Securities Commissions (IOSCO), the International Association of Insurance Supervisors (IAIS), the World Bank and the Financial Stability Forum (FSF) participate. The ongoing developments in the financial markets make it important to monitor financial stability across the different financial sectors and geographical regions.

**Core Principle Liason Group:** Senior representatives of the core BCBS member countries, of the non-G10 supervisors, the European Commission, the IMF, World Bank and the FSF regularly at this high-level forum. At this forum, technical issues are discussed and one oversees the application of the core principles. It co-ordinates the main agenda points of the BCBS with non-G10 supervisors and provides assistance on the BCBS guidance issued, especially on international implementations and cross-border issues. A special working group on capital focuses on the implementation in non-G10 countries.

**Cross-Border Banking Group:** The group consists of members of the BCBS and of the offshore group of banking supervision. Attention points or cross-border banking supervision [54] together with money-laundering and terrorist financing.

**Research Task Force:** Research economists of member institutions gather on specific research topics. It provides a communication forum for member economists, researchers and academicians working on financial stability issues.

The BCBS secretariat assists on the secretarial work of the different work groups and gives advice to supervisory authorities in all countries.

The topics these different subcommittees cover reveal the complexity of international banking supervision. The BCBS also has an active role in the joint forum and co-ordination group, where supervisors of financial institutions address issues common to banking, insurance and securities sectors. Such a co-ordination is increasingly important for the regulation of financial conglomerates [73, 190, 517].

## 1.8 Financial products

This introductory chapter is concluded with a concise overview of financial products. First, equity products are discussed for corporations and other legal entities or artificial persons in law more generally. Debt products, which can

also be “emitted” by natural persons, are discussed next. Derivatives and structured products are the topic of the subsequent sections. Finally, other products like factoring, leasing and liquidity facilities are discussed.

### 1.8.1 Equity

Common stocks, also referred to as equities or shares, are securities that represent ownership in a corporation [291, 342]. Common stocks are used by firms in the primary market to obtain long-term funds from investors. In return for their investments, the investors receive dividend payments and surplus value of the company.

Companies can have private and public ownership; in the latter case the stocks are publicly traded. An initial public offering (IPO) is a first-time offering of shares by a corporation to the public. Note that the issuing firm is not obligated to repurchase the stocks from the investors at any time, but the public stockholders can trade the stocks in the secondary market.

The common stockholder has voting rights for the important firm decisions like the election of the board of directors or whether to issue new stocks. In return for their investment, investors get dividend payments when profit is made. Preferred stocks have a higher priority than common stocks and allow for a fixed dividend payment. Preferred stock investors usually have no voting rights. They are senior to common stocks, but junior to bonds as indicated in Fig. 1.4.

Stock exchanges facilitate the trading of existing publicly owned stocks in the secondary market [342]. Organized stock exchanges are organizations of brokers and investment bankers that facilitate the trading of stocks and other financial instruments. Examples are the New York stock exchange (NYSE), the American stock exchange (AMEX), the electronic screen-based stock-market National Association of Securities Dealers Automated Quotation system (NASDAQ), the pan-European stock exchange Euronext and the London Stock Exchange (LSE). On exchanges, the trades are made by a price mechanism. Some exchanges state bid and ask prices of securities at which market parties are willing to buy and sell. The bid price is the highest price at which one wants to buy, the ask price is the lowest one at which one wants to sell. The mid price is the arithmetic or geometric average of the bid and ask price. The bid–ask spread is the difference between the bid and ask price. In liquid markets, the spread is typically low. In illiquid markets, the difference in price perception between buyers and sellers becomes higher

and the spread increases. Bid and ask price are typically provided by market makers by which customers can trade. Other exchanges do not report bid–ask prices, but state the price on which the last trade was made, match buy and sell transactions and charge a transaction fee. Trades involve transaction costs: depending on the exchange, buy/sell prices may differ and/or fees are paid to brokers and the exchange.

In the over-the-counter (OTC) market, stocks not listed on organizational exchanges are traded in direct negotiations between buyers and sellers. Unlike the organized stock exchanges, OTC markets do not have a trading floor, but typically use a telecommunications network to handle the buy/sell orders. Stock indexes are used to summarize the performance of stock markets, or segments thereof. Popular examples are the Dow Jones Industrial average, the Standard and Poors (S&P) 500, and the New York Stock Exchange indexes. Stock quotations usually include the price earnings ratio (PE ratio, earning multiple) which is defined as the ratio between the market price per share and the earnings (net income) per share during the previous 12 months. Investors use the PE ratio to compare stocks and prefer stocks with low PE ratios.

The common investment strategy is to buy a stock, such positions are called long positions. A long position allows an investor to benefit from upward market price movements of the stock and dividend payments. An alternative stock investment strategy is the short sale, whereby an investor sells a stock he does not own (short the stock). The short-sale investor essentially borrows the stock from another investor, sells it in the market, and then repurchases the stock afterwards to return it to the investor from whom he borrowed. The short position allows investors to profit from downward stock price movements. The uncertainty of equity price movements represents a risk that is commonly treated in market and credit risk analysis.

Many institutional investors such as pension funds, mutual funds, and insurance companies hold large proportions of shares in their portfolios, and as such, have a significant impact on firm decisions.

### 1.8.2 Debt

Debt is created when a creditor lends money or assets at a certain date to a debtor. The debtor agrees to repay the received money in addition to interests and/or fees. The reception and repayment schedule of the money is usually contractually agreed upon.

## 62 Bank risk management

A simple debt instrument is where the creditor lends a principal sum for a fixed period of time and, in exchange, the debtor agrees to repay this principal sum at the end of the period and to make periodic interest payments. In some cases, additional fees can be charged by the creditor (e.g., to cover administration expenses) or the principal sum to be repaid is less than the loan amount given by the creditor (e.g., in countries where interest charges are not allowed).

As opposed to equity, debt instruments typically have no ownership interest [415]. In other words, the creditors have no voting rights. In return for the debt security, the borrower repays the lender as contractually agreed. Repayments may consist of principal, interest and fee payments. Debt instruments are often called fixed-income securities, because they guarantee specific payments on fixed dates. Furthermore, creditors have legal recourse when payments are being missed and have higher priority rights than shareholders in the case of a default event (Fig. 1.4). In contrast to dividends, interest is considered a cost of doing business and is tax deductible.

Excess debt can lead to financial distress or bankruptcy, whereas an all-equity firm can never go bankrupt, at most shareholders can lose their equity investment. Debt instruments expose investors to credit risk and to market risk in the case of traded securities. Different types of debt instruments are elaborated upon in the next paragraphs.

### 1.8.2.1 Loans, mortgages and revolving credits

A loan is a debt type, it is a form of contract between the debtor and creditor, where the debtor repays a sum of money at a future date in return including interest charges and/or fees. Most loans are bilateral contracts between the debtor and the creditor. Syndicated loans involve multiple creditors, often banks or financial institutions, that co-operate to provide funding in the form of a large loan to a large borrower. Syndicated loans involve a more complex organization, but reduce concentration risk.

An installment credit or loan entails the lending of one lump sum that is repaid with periodic (e.g., monthly) payments of principal and interest during a pre-determined time period, according to an agreed loan amortization table. Popular examples are car loans, personal loans, vacation loans, and student loans. The amount can be fully taken up at the start of the contract, or piecewise during an agreed period. A bullet or balloon loan is a loan whereby only interest is paid during the loan term, with a final balloon payment

of principal at the end of the loan. Installment credits can be secured or non-secured.

A mortgage loan is an installment loan secured by real estate property. A distinction can be made between a residential mortgage and a commercial mortgage depending on whether the underlying real estate collateral is used for residential or commercial purposes. Home equity loans use the equity (the market value of a property minus the outstanding loans) of a borrower's home as collateral. Collateral reduces the loss risk.

With a revolving credit, the borrower is repeatedly allowed to consume credit up to a pre-determined credit limit, as periodic repayments are being made. Examples of revolving credit facilities are credit lines and credit cards. A credit line or line of credit is a credit facility agreed for a specific time period. The borrower may consume credit whenever needed, up to the limit. Repayments are being made according to a fixed or non-fixed schedule. Interest is only charged for the consumed credit amounts. The line of credit can be secured or non-secured. Credit lines allow firms to have increased liquidity. The most popular example of a credit line in the retail business is the credit card, which is a plastic card with a magnetic strip that can be used to buy goods and services on credit. For most credit cards, a monthly repayment scheme is assumed. A secured credit card is a credit card linked to a savings account, which can be used as collateral in case the borrower does not pay back. The overdraft facility is another example of this product category: it allows bank customers to withdraw more money from their account than is actually available. The negative balance or amount overdrawn is limited by a prior agreement with the customer for which a normal interest rate is charged. For higher overdrafts, typically higher rates apply and penalty fees are charged. For retail customers, the overdraft limits are often defined in the framework of a protection plan to prevent unlimited spending. Credit lines represent an important exposure risk: because the borrower can draw funds at his convenience (e.g., to cover unforeseen events during large projects), the exposure amount at default is not known beforehand.

Loans have similar characteristics as bonds: seniority, payment structure, . . . These issues are discussed below.

### 1.8.2.2 Bonds

A bond is a long-term debt security issued by government agencies or corporations whereby the borrower makes periodic interest (or coupon) payments to the bondholder at specified dates (e.g., annually or semiannually), and



## 64 Bank risk management

the face or par value at the maturity date [342]. For simple bonds, the face value equals the principal amount, the latter is also referred to as the amount borrowed. The maturity is the end date of a security. Bonds typically have maturities between 5 and 30 years.

When bonds are issued by the debtor on the primary market, the most common process is via underwriting. Debt underwriting has been an important activity of investment banking: underwriters assume the responsibility for the distribution and guarantee a price in exchange for fees and profits when reselling the bonds to investors. If the bonds cannot be sold at the offering price, underwriters can decide to hold the securities for themselves or place them in the market at a discount. After emission on the primary market, investors may sell and buy bonds. Compared to equity, bonds are primarily traded in the OTC market. Older bonds often trade less liquid, they are said to trade at a liquidity premium. Bonds have similar properties to loans, it is a loan in the form of a security. Like for equities, there also exist bond brokers where one can open an account to invest.

The yield of a bond can be defined in multiple ways. The coupon yield (nominal yield) of a bond is the coupon payment as a percentage of the face value. The current yield is the coupon payment as a percentage of the bond market price, whereby the latter is obtained as the present value of all future cash flows. The yield to maturity is the discount rate that returns the market price of the bond. It reflects the rate of return that an investor would earn if he bought the bond at its current market price and held it until maturity. As such, the yield to maturity is the sum of the current yield and the capital gain yield. A bond selling below its face value (e.g., because of high market interest rates) is trading at a discount with a yield to maturity higher than the current yield, and a current yield higher than the coupon yield. A bond trading above its face value (e.g., because of low market interest rates) is trading at a premium with a yield to maturity lower than the current yield, and a current yield lower than the coupon yield. A bond is considered to be a par bond when the price equals its face value and the yield to maturity equals the current yield and the coupon yield.

Many different types of bonds exist, the following categorization can be made:

### **Issuer origin and currency:**

**Domestic bond:** a bond denominated in the currency of the country where it is issued,

**Foreign bonds** a bond denominated in the domestic currency but issued by a non-resident,

**Eurobonds:** a bond issued and traded outside the country whose currency it is denominated in,

**Dual currency bonds:** a bond denominated in one currency, but paying interest in another currency at a fixed exchange rate.

**Issuer type:** Bond issuers can be both public or private:

**Government bond:** issued by a central government in the domestic currency.

**Sovereign bond:** issued by a central governments in a foreign currency.

**Government agency and guaranteed bond:** issued by a government agency or guaranteed by the central government. A popular example are the Treasury-bonds (T-bonds), which are bonds with maturities of 10 years or more, backed by the US government.

**State or local bond:** issued by a local government (e.g., state, county, region, province, school district, municipality)

**Firm bond:** issued by private and public corporation.

**Debt repayment schedule:** The repayment schedule depends of the timing of the principal, interest and fee payments (Fig. 1.12):

**Fixed-coupon bond:** periodical payment of interest and a one-time balloon payment of principal at maturity.

**Zero-coupon bond:** no periodic interest payment, only a one-time balloon payment of principal at maturity.

**Annuities:** payment of a constant amount over time including interest plus amortization, or gradual repayment, of principal.

**Perpetual bond:** one pays interest coupons forever, with no maturity date.

**Step-up bond:** start with low coupons that increase over time.

Instead of a fixed interest rate, one can also choose variable or floating rates:

**Floating-rate notes (FRN):** pay a variable coupon equal to a reference rate (e.g., LIBOR) and a constant spread.

**Inverse floaters:** coupon rate varies inversely with a reference rate (e.g.  $x\% - \text{LIBOR}$ ).

**Inflation-linked bonds:** in these instruments, the principal is indexed to inflation, which also increases the coupon or interest payments. These

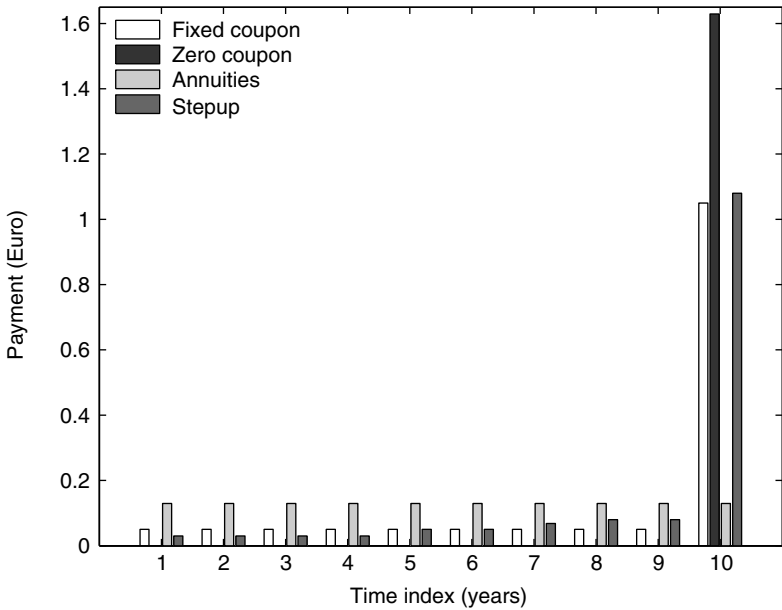

**Fig. 1.12** Repayment schedule in the case of a flat interest rate of 5% for a fixed-coupon bond, zero-coupon bond, annuities and step-up bond. Payments are made annually for a period of 10 years and for an amount of €1.

instruments typically have a lower interest rate, because the inflation risk is already covered.

Structured notes have more complex coupon patterns tailored to the investor’s needs.

**Option characteristics:** Some bonds have additional option characteristics:

**Callable bond:** issuer has the right to redeem the bond prior to maturity, at fixed prices on fixed dates. Such pre-payment features are also available for loans.

**Puttable bond:** bondholder has the right to put or sell the bond back to the issuer, at fixed prices on fixed dates.

**Convertible bond:** the bond can be converted into common stock of the issuing company (or more generally into other assets like cash or other debt), at a fixed price on a fixed date. Such conversion is interesting when the share price rises and, hence, such bonds have lower yield to compensate the upward value of the option.

**Reverse convertible bond:** the bond has similar features to the convertible bond, but differs by the property that the issuer can decide whether

or not to apply the conversion option. Such bonds are more risky for the bondholder and typically trade at a higher price and shorter maturity. The price of a bond with option characteristics is the combined price of the option features and the basic bond. Put features are often defined in covenants that define additional features of the bond contract, e.g., it may define maximum leverage or minimum rating requirements of the issuing company that may trigger the sell-back right when these levels are breached. The conversion ratio of convertible and reverse convertible bonds is specified at the issuance of the bond.

**Seniority:** Bonds can be differentiated according to the seniority of their claims on the firm's assets in the case of default. In the case of bankruptcy, the absolute priority rule states that the remaining value of the company should be distributed such that senior bondholders are considered before junior bondholders [432]:

**Senior secured bonds:** bonds that are secured by collateral.

**Senior unsecured bonds:** unsecured bonds (not secured by collateral), that have the highest priority amongst unsecured bonds.

**Subordinated bonds:** subordinated bonds have lower priority, often in exchange for a higher yield. In some bond markets, like the US the priority of subordinated bonds is further organized in senior subordinated, subordinated and junior subordinated bonds.

Figure 1.4 gives an overview of the bond seniority structure.

**Maturity:** The maturity of bonds can vary considerably. Originally, a specific nomenclature existed depending on the maturity:

**Bill:** the maturity ranges up to one year (short-term),

**Note:** the maturity ranges from 1 to 10 years (medium-term),

**Bond:** the maturity exceeds 10 years (long-term).

The strict difference of the nomenclature has become blurred nowadays, the term bond is also generally applied. Securities with a longer maturity are more subject to interest rate risk, as indicated by the duration (eqn 1.1). Longer-term securities also bear higher credit risk as the credit quality of the borrower may deteriorate over time. In developing countries, the market for longer-term products can still be developing because of the volatile interest rates and risk levels due to lacking macroeconomic stability.

The above features are not only applicable for bonds, but also for other debt instruments like loans.

### **1.8.2.3 Bank debt**

Banks fund their investments by issuing different types of debt instruments as illustrated in Fig. 1.1. On top of different bond types in terms of seniority and maturity, an important funding source for many banks are savings accounts. Savings accounts allow investors (mainly household families) to receive interest returns on their liquid assets. The received interest payments are typically more limited than on other products, to compensate for the liquidity of the invested funds. In many cases, savings account offer unlimited access to the funds, which makes savings account deposits almost equivalent to cash. Deposits on savings accounts are often guaranteed by deposit insurance plans and regulations. Not all types of transactions are allowed by savings accounts, e.g., retrieving money by ATMs or issuing bank cheques. Such transactions are made from transactional accounts, current accounts, checking accounts or demand accounts. In most cases, these accounts are also debt instruments (unless overdrafts are made) offering a limited interest rate in return for the transaction servicing.

### **1.8.2.4 Leasing**

A lease is an agreement whereby the lessor purchases assets (equipment, resources or durable consumer goods), and makes those available to the lessee during a specific term, and for a contractually agreed payment. The lessor still remains the legal owner of the leased goods. Lease contracts typically have a purchase option, which will allow the lessee to purchase the goods at the maturity of the contract and at an agreed price (residual value). In a financial lease (capital lease) agreement, the lessee is responsible for maintenance, taxes and insurance, whereas in an operational lease, the lessor will take care of this. Operational leases are typically shorter term (e.g., less than 5 years) than financial leases. A lease contract is a broad form of a debt instrument with the lessor and lessee corresponding to the creditor and debtor, respectively.

## **1.8.3 Derivatives**

A derivative instrument is a contract, between two or more parties, whose value derives from the value of one or more underlying assets (e.g., stock, bond, currency, commodity, interest rates, market indices) at a particular time or period in time. The amount of underlying assets on which the derivative contract is defined is called the notional amount. These instruments are

commonly used to speculate on future expectations or to reduce portfolio risk [342].

Over-the-counter (OTC) derivatives are privately negotiated and traded directly between two or more parties. Such derivatives are tailored to the counterpart's needs. Exchange-traded derivatives are traded on specialized derivative exchanges (e.g., Chicago Mercantile Exchange, Tokyo Commodity Exchange, Korea Exchange, Euronext Liffe, Eurex in Europe) and on equity exchanges, where the derivative exchange acts as an intermediary between the parties.

Derivative contracts can be cash-settled or physically settled. In cash-settled contracts, cash flows are paid in cash, whereas the other contracts stipulate the physical delivery of the underlying. Different types of derivatives exist, the main types<sup>9</sup> are futures, forwards, options and swaps:

**Forward:** A forward contract is an agreement to exchange a given asset for another asset (e.g., cash) at an agreed future point  $T$  in time. The forward agreement specifies the number of units exchanged, the price (forward price) and date (delivery date, settlement date). A position to buy (sell) the asset is said to be long (short). The forward contract separates the date of trade and delivery. The difference between the current or spot price<sup>10</sup> of the asset  $A_0$  and the forward price  $A_T$  is the forward premium or discount. Given the forward price  $F$ , and the asset price  $A_T$  at maturity  $T$  (settlement price), the pay-off of the forward contract at expiration, per unit of the underlying asset is:

$$\text{Pay-off(long forward)}_T = A_T - F,$$

for a long position. For a short position, the pay-off is:

$$\text{Pay-off(short forward)}_T = F - A_T.$$

A long (short) position in a forward contract will give a profit (loss) when the asset price at maturity exceeds the forward price, and vice versa. The net profit is obtained by correcting for the price value  $V_0$  of

<sup>9</sup> In this section, the interest rate is assumed to be zero for the sake of simplicity of notation. It is straightforward to compensate for the time value of money in the cash flows. Transaction costs between buyer and seller are neglected.

<sup>10</sup> The spot price is the price at which the asset is transferred, at the spot date; which is typically around two business days after the trade.

the forward contract:

$$\text{Net pay-off(long forward)}_T = A_T - F - V_0,$$

$$\text{Net pay-off(short forward)}_T = F - A_T + V_0.$$

Figure 1.13 depicts the pay-off patterns for long and short positions in a forward contract. It is important to note that the pay-offs are linear in the underlying asset value  $A_T$  and symmetric providing both gains and losses. Forward contracts are typical OTC products.

**Future:** Future contracts or futures are closely related to forward contracts, but are standardized (e.g., in terms of expiration dates, amounts, currency) and are traded on organized derivative exchanges. Whereas forward transactions are only possible at the trade and maturity or settlement date, it is possible to trade futures on exchanges, which makes them more liquid. Futures are highly standardized, with specifications of the underlying, quality, cash/physical settlement, amount, settlement, . . . Future exchanges require initial margins to be paid by both buyer and seller to cover possible price evolutions during one day. Depending on the price evolution, one of the market participants is called to refill the margin amount up to the required level. Such margin calls limit the credit risk between the participants as the price evolutions are covered by margin accounts, which is an advantage compared to forward contracts.

**Option:** An option is a financial contract whereby the buyer has the right, but not the obligation (as opposed to forwards and futures), to buy (call option) or sell (put option) a commodity or underlying asset from the seller (option writer) at a certain price (strike price, exercise price), and

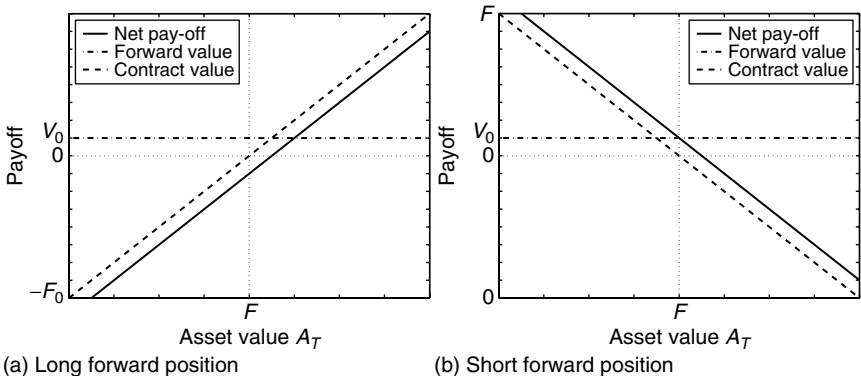

**Fig. 1.13** Profit and pay-off diagrams for long and short positions on forward contracts.

until a specified expiration date. The buyer pays a premium fee for this right. When the asset price is such that the option can be exercised with a profit (loss), the option is said to be in-the-money (out-of-the-money). There exists a wide variety of option contract types:

**Pay-off structure:** Classical call (put) options pay the positive (negative) difference between the asset price and the strike price as discussed below. The pay-off structure is piecewise linear as illustrated in Fig. 1.14. More exotic options have specific characteristics. A binary option (digital option) pays a fixed amount depending on the price of the underlying instrument at maturity. A barrier option is an option whereby the option to exercise depends on whether the price of the underlying instrument hits a barrier during a certain period of time. A knock-out option expires worthless if the price hits the barrier, whereas a knock-in option (trigger option) only starts to exist once the barrier is met.

**Exercise time or period:** European options can be exercised only at the option expiration date, whereas American options can be exercised at any time before maturity. A Bermudan option is an option that can be exercised at a set number of times. An Asian option is an option where the pay-off depends on the average price of the underlying security observed over a pre-set period of time.

**Covered vs. uncovered:** A naked (uncovered) option is an option whereby the option writer has no offsetting position. For example, a naked call option, is a call option whereby the seller does not own the underlying financial security.

The pay-offs at expiration date  $T$  for long and short positions when having bought or sold (written) a call or put option depend on the evolution of the underlying asset value. The net profit or loss at the expiration date is the pay-off plus or minus the annualized option contract value at the expiration date. The value of the put and call option contract at time zero is denoted by  $P_0$  and  $C_0$ , respectively. The pay-offs and net profits/losses for different European option positions are:

**Long call:** One has invested in a call option that allows one to buy the asset at the strike price  $F$ . This right will be exercised when the asset price  $A_T$  exceeds the strike price  $F$  as the investor gets a net asset worth  $A_T$  at the strike price  $F$ , giving the investor a net profit. The pay-off



## 72 Bank risk management

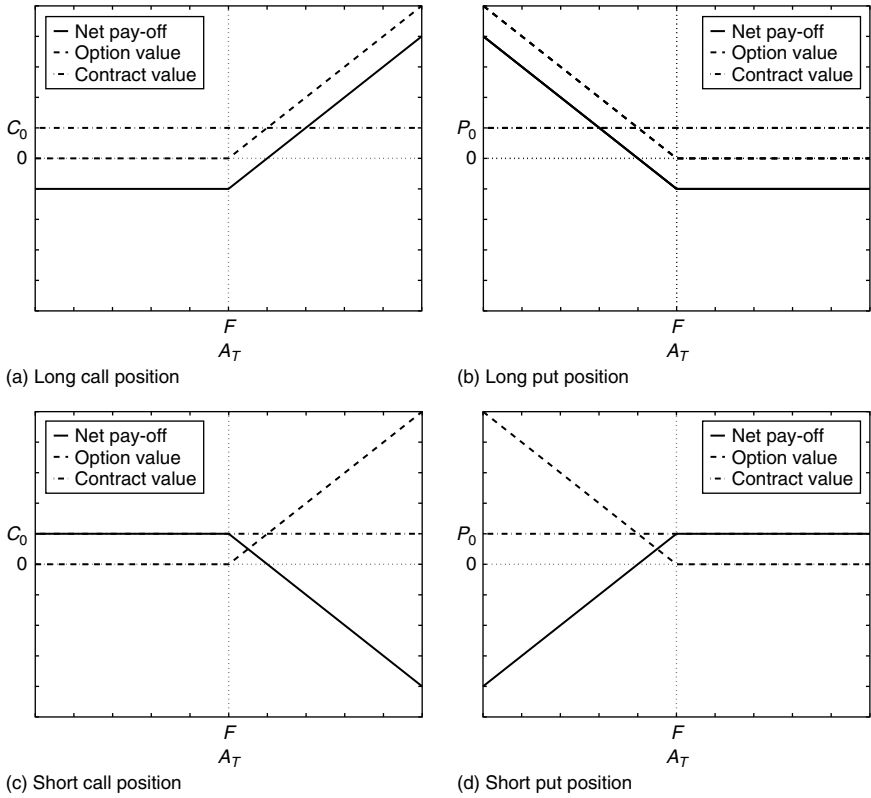

**Fig. 1.14** Profit and pay-off hockey stick diagrams for long and short positions on plain-vanilla call and put options.

and net profits or losses of the option at expiration date  $T$  are

$$\begin{aligned} \text{Pay-off(long call)}_T &= \max(0, A_T - F), \\ \text{Net profit(long call)}_T &= \max(0, A_T - F) - C_0. \end{aligned} \quad (1.2)$$

**Long put:** One has invested in a put option that allows one to sell the asset at the strike price  $F$ . This right will only be exercised when the asset price  $A_T$  is below the strike price  $F$  at the expiration date  $T$ . The pay-offs of the option at expiration date  $T$  are

$$\begin{aligned} \text{Pay-off(long put)}_T &= \max(0, F - A_T), \\ \text{Net profit(long put)}_T &= \max(0, F - A_T) - P_0. \end{aligned} \quad (1.3)$$

**Short call:** One has sold a call option that allows one to buy the asset at strike price  $F$ . This right will be exercised by the option holder when the asset price  $A_T$  exceeds the strike price  $F$ . The pay-offs of the option at expiration date  $T$  are

$$\begin{aligned}\text{Pay-off(short call)}_T &= -\max(0, A_T - F), \\ \text{Net profit(long call)}_T &= -\max(0, A_T - F) + C_0.\end{aligned}\tag{1.4}$$

**Short put:** One has invested in a put option that allows one to sell the asset at the strike price  $F$ . The option holder will exercise this right when the asset price  $A_T$  is below the strike price  $F$  at the expiration date  $T$ . The pay-offs of the option at expiration date  $T$  are

$$\begin{aligned}\text{Pay-off(short put)}_T &= -\max(0, F - A_T), \\ \text{Net profit(short put)}_T &= -\max(0, F - A_T) + P_0.\end{aligned}\tag{1.5}$$

Note that a negative net profit corresponds to a net loss in the above expressions.

The possible pay-offs are visualized as a function of the underlying asset value at maturity  $T$  in Fig. 1.14. The pay-offs are a non-linear function of the asset value. Depending on the position, there is a limited downside risk, but unlimited upside return and vice versa.

The above options are also called plain-vanilla options, due to their simplicity. These simple options are also used as building blocks to design and understand more complex exotic options that can be found in specialized textbooks.

**Warrant:** A warrant is a security that entitles the buyer to buy shares of a company at a specified price. Although very similar to call options, warrants tend to have a longer duration, and are typically not standardized. Furthermore, if warrants are exercised, the exercise money represents a cash inflow to the firm, and the number of outstanding shares increases. Warrants are often issued together with bonds or preferred stocks to entice investors, thereby allowing the issuer to pay lower interest rates. Warrants have no right to dividends and no voting rights. They are traded on derivative and equity exchanges.

**Swap:** A swap is a derivative whereby two parties agree to exchange a series of cash flows according to pre-specified terms [291]. Swaps are mostly traded over-the-counter (OTC).

## 74 Bank risk management

There exist a wide variety of underlying asset types. The earliest form of underlying types were agricultural products (e.g., cattle and grain). Nowadays, financial assets have become the most important underlying: equities, equity indices, commodities, credit and debt products, exchange rates and interest rates. More recently, inflation, weather gained importance. Some examples of financial derivatives are:

**Fixed-income derivatives:** Fixed-income derivatives are derivatives whose value derives from a bond price, interest rate, or other bond market variable [291]. Examples include:

**Forward rate agreement:** A forward rate agreement (FRA) is an OTC contract between parties that locks in an interest rate (or currency exchange rate) to be paid or received on an obligation starting at a future time. Typically, FRAs are cash-settled and only the differential is paid on the agreed notional amount of the contract.

**Eurodollar futures:** Eurodollar futures are futures contracts fixing a forward interest rate (typically tied to the LIBOR rate) on a three-month deposit of usually one million dollars. At expiration, these contracts are mostly settled in cash. Variants are Euribor futures (denominated in Euros), Euroswiss futures (denominated in Swiss francs), and Euroyen futures (denominated in Japanese yen).

**T-bond futures:** T-bond futures are futures contracts tied to a pool of treasury bonds (T-bonds, see above) all with a remaining maturity greater than 15 years. Similar contracts also exist with shorter maturities.

**Interest rate swaps:** Interest rate swaps are swaps linked to interest rates. In a fixed-for-float interest rate swap, one party receives a fixed interest rate in return for paying another party a floating interest rate for an agreed notional amount and time horizon. In float-for-float interest rate swaps, floating interest rates are exchanged.

**Cap:** A cap is a call option on the future realization of an underlying interest rate (typically LIBOR). More specifically, it is a collection (strip) of caplets each of which is a call option on the LIBOR at a specified future date. In a similar way, a floor is a strip of floorlets, each of which is a put option on the LIBOR at a specified future date.

**Swaption:** A swaption is an OTC option giving the buyer the right to enter a swap at a specified date. The writer of the swaption becomes the counterparty to the swap if the buyer exercises. The most popular swaptions are interest-rate swaptions, although swaptions on equities, currencies, and commodities are also possible.

**Equity derivatives:** Popular equity derivatives are

**Stock index future:** A stock index future is a futures contract to buy or sell a fixed value of the constituents of a specific stock index. The contracts are cash-settled at maturity.

**Single stock future:** A single stock future is a futures contract to buy or sell a certain amount of individual stocks at a set price.

**Equity swap:** Equity swaps are swap agreements to exchange a set of future cash flows tied to the return on a stock or stock market index in exchange for a fixed or floating interest rate.

**Equity option:** The underlying is the single equity. Such contracts exist for the most important stocks (blue chips). On some equity markets, standardized contracts are traded in the form of warrants.

**Index option:** The underlying is an index of stocks, either an existing index or a newly defined index tailored to the counterpart needs.

Equity derivatives are important building blocks to define mutual funds with capital guarantee, which basically consists of a zero-coupon bond to guarantee the capital and equity options to profit from upward market movements.

**Credit derivatives:** Credit derivatives are OTC contracts aimed at exchanging credit risk between parties. The credit risk is transferred from the protection buyer to the protection seller. Credit derivatives boomed recently with multiple product types:

**Credit default swap:** A credit default swap is a bilateral swap agreement whereby a protection buyer pays a (periodic or lump sum) premium to a protection seller, in exchange for a contingent payment by the seller in the case of a credit event (such as default, debt restructuring) of a third-party credit issuer occurs. Figure 1.15 depicts the cash flows in the case of a physically settled CDS: upon default the buyer transfers the defaulted bond and receives the protected amount from the seller. The CDS market is the most popular credit derivative market. Whereas CDS contracts are traded OTC, standardized credit default swap indices are standardized products to hedge portfolio credit risk. These indices trade more liquidly, with lower bid–ask spreads. The main indices are iTraxx (Europe) and CDX (North America and Emerging Europe).

**Total return swap:** A total return swap is a swap agreement whereby the protection buyer makes payments based on the total return of a reference asset (e.g., a bond) to the protection seller, in exchange for receiving payments tied to a fixed or floating reference rate (e.g., LIBOR). The

## 76 Bank risk management

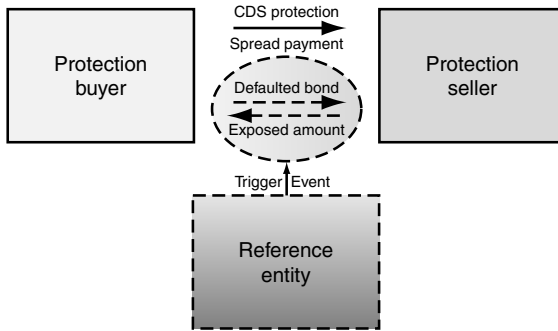

**Fig. 1.15** Cash flows in a physically settled CDS: in the case of a default trigger event, a payment is made to the protection buyer of the CDS in return for the bond or loan amount for which protection has been bought. In exchange for the protection bought, the buyer makes regular payments to the seller up to the default event.

total return includes capital gains, interest payments, but also losses. The total return swap provides a wider protection than CDS, which protects only in case of a default event.

**Credit spread forward:** A credit spread forward is a cash-settled contract whereby the buyer receives (pays) the difference between the credit spread at maturity, and an agreed-upon spread, if positive (negative).

**Credit spread option:** A credit spread option is an option contract giving the buyer the right to redeem the difference between the credit spread and the agreed strike spread, from the seller at maturity.

**Credit-linked note:** Credit-linked notes are securities issued by a special-purpose company or trust that combine a regular high-quality coupon-paying note or bond with a short position in a credit default swap. The coupon payments depend on the credit risk performance of a reference asset: in the case of default, credit migration or other credit event, the coupon payment can be reduced. The purpose is to transfer a higher credit risk to the investor, in return for higher yields.

In addition to these products, other products exist as well, some of which have as underlying other credit derivatives. For example, a CDS option gives the right to buy or sell in the future a CDS at a given strike spread. Some credit derivatives are related to structured products, that are discussed in a separate section below.

### 1.8.4 Structured products

A structured product is a broad term to indicate a product that is based upon a pool of underlying assets in which the risk is transferred via a complex

legal structure, and in which the credit risk of the originator that owned the assets is decoupled from the pool. Structured products have three main characteristics [119]:

1. A pool of assets is created. The creation is either cash-based or synthetically.
2. Liability tranches are defined that have different cash flows from the same asset pool. By giving different priorities to the cash flows of the different tranches, tranches with different risk characteristics are defined.
3. The credit risk of the originator is separated from the pool by the creation of a bankruptcy-remote special purpose vehicle (SPV) or special purpose entity (SPE). The SPV is a stand-alone entity defined for the lifetime of the structured product that “owns” the asset pool.

Structured products repackage other financial instruments, mostly debt instruments.

Structured products are often the result of a securitization process whereby new financial instruments or securities are created based on asset pools. The process is depicted in Fig. 1.16. The total amount of structured products issuance exceeded 1400 billion USD in 2003 [119]. Securitization reduces the role of banks as a financial intermediary and emphasizes their brokerage function.

Figure 1.17 depicts the composition of a tranching structured product. The pool of assets (e.g., BB high-yield bonds or loans) contains hundreds to thousands of assets. The interest and principal cash flows of the pool are distributed over several tranches according to a specific structure specified in the contract. Typically, a waterfall structure is applied where the cash flow prioritizes the higher tranches. Lower tranches absorb the losses first, then the higher tranches. The lowest tranche is the first loss tranche and is called the equity tranche that will receive the remaining income of the pool’s cash flow after the higher tranches have been paid according to the contract. If the equity tranche has absorbed all the losses, the mezzanine tranche will absorb the next losses. In return, the mezzanine tranche will achieve a higher (fixed) coupon than the senior tranches. Such tranches are said to offer a good risk-return income. There are various ways to specify the priority of payments (e.g., principal or interest only, pre-payments, first loss approach or pro rata distributions) that are legally specified in the contract of the structured product. Such transactions involve legal risk management to ensure that the assumed cash flows hold under all plausible scenarios. Observe that the structuring does not change the total risk. The structure allows one to change the risk of, e.g., a homogeneous pool of

78 Bank risk management

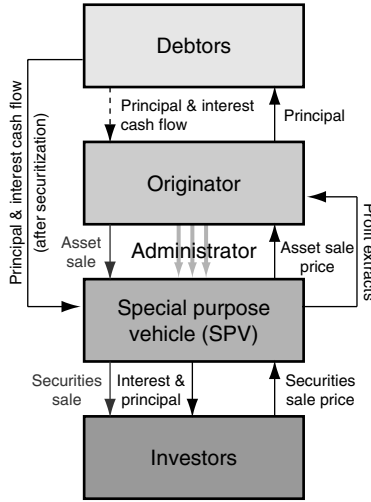

**Fig. 1.16** Cash flow statement of structured products: debt from the originating bank is transformed via the administrator to a special purpose vehicle (SPV) or special purpose entity (SPE). In return for the asset transfer where the SPV receives the asset cash flows, the originating bank receives the asset sale price and profit fees from the SPV. The SPV structures the asset cash flow and sells the structured securities to investors.

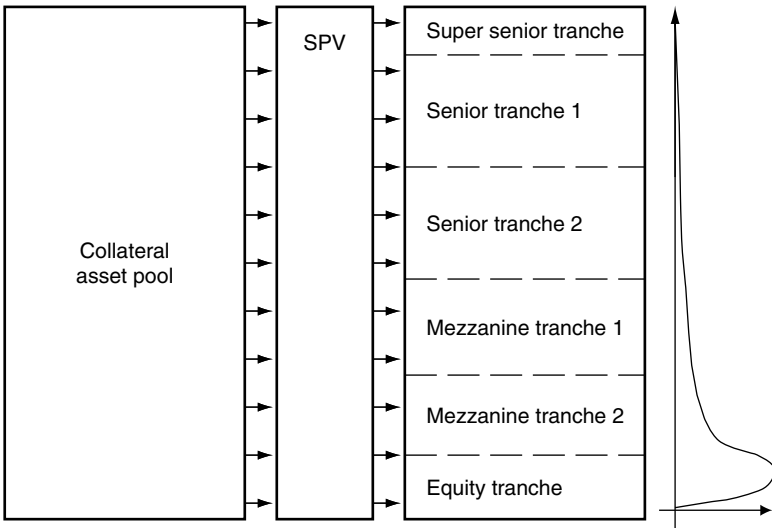

**Fig. 1.17** Tranching: the revenues of the asset pool owned by the SPV are redirected to different tranches. The higher the tranche, the higher the priority; the lower the risk and return. The total risk, illustrated by the loss distribution, does not change, but the risk of the tranches depends on the default correlation [2, 263, 264].

BB-rated bonds to various tranches that are attractive to different investor types.

Various parties are involved in a structured product. The originator sells the assets to the SPV. The arranger sets up the structure. The servicer takes care of the asset pool and collects payments. A trustee oversees the distribution of cash and compliance with the contract and deal documentation. Rating agencies provide ratings to the different tranches. For some products, the asset pool is actively managed by an asset manager. Financial guarantors or monoliners may provide financial protection to investors for some tranches.

There exist different types of structured products as illustrated in Fig. 1.18 [2, 134, 133, 119, 326, 504, 520]:

**Mortgage-backed securities:** If the underlying securities are mortgages (residential or commercial), the securities issued by the SPV are referred to as mortgage-backed securities (MBS). Residential mortgage debtors may repay more than the monthly payment to reduce the remaining principal. Such pre-payment possibilities are often made when interest rates decrease. The pre-payment risk represents an additional risk on the revenues of the investors. Commercial MBS have fewer pre-payment facilities.

**Asset-based securities:** Asset-backed securities (ABS) are securities backed by one of the following type of assets: automobile loans, consumer loans, future receivables, equipment leases, credit and receivables, trade

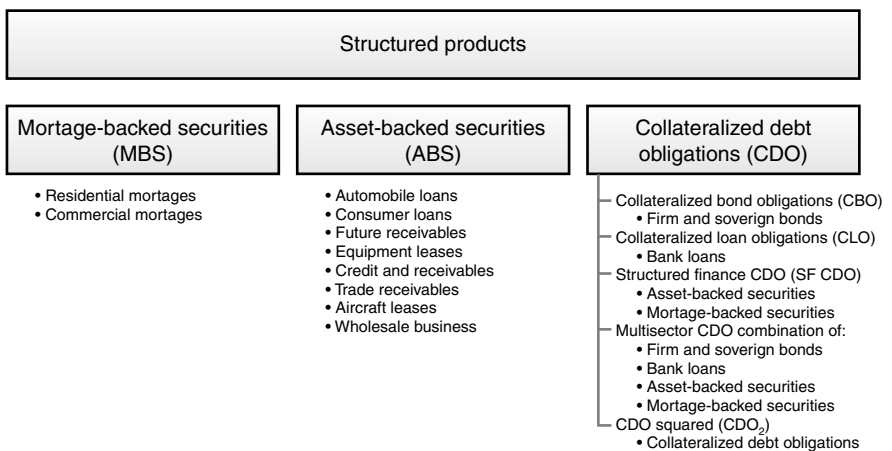

**Fig. 1.18** A classification of structured products. [2, 119, 133, 134, 326, 504, 520].



receivables, aircraft leases, or whole business. Note that not all ABS define tranches to structure the risk. Such ABSs are called passthrough asset-backed securities. In Europe, a popular alternative to ABSs are covered bonds that have the same structure as passthrough ABSs but are not delinked from the issuing bank and remain on the balance sheet [21, 172, 435].

**Collateralized debt obligations:** Another type of structured products are collateralized debt obligations (CDO) of which 5 different types exist depending on the underlying assets. When the underlying assets are firm or sovereign bonds, the CDO is called a collateralized bond obligation (CBO). When the underlying portfolio consists of loans, the CDO is referred to as a collateralised loan obligation (CLO). Structured finance CDOs are CDOs backed by ABS or MBS. A multisector CDO is a CDO backed by a combination of firm bonds, loans, ABS, or MBS. A squared CDO is built of CDOs backed by other asset classes (Fig. 1.18).

Apart from the different collateral types, the structured products can also be defined in terms of the number and types of tranches, the type of waterfall structure, static or active pool management, etc.

A main motivation for structured products issuance has been funding and balance sheet management. By issuing assets, the bank reduces its assets and improves its gearing and capital to risk ratio. The sold assets generate a direct cash income and the freed asset space can be used to invest in new assets. Such operations are important for banks that have strict regulatory capital requirements or that want to maintain a target capitalization level.

The sale of illiquid assets via more liquid structured products provides an attractive and alternative way of funding. Lower-rated issuers will receive lower interest income when holding better-rated bonds. For example, when the funding money for an AA firm bond on the liability side is obtained by a BBB bond issued by a bank, the interest expenses exceed the interest income. By issuing the BBB bonds via a SPV (without the credit risk of the issuing bank), the bank is still able to invest in AA bonds.

Apart from balancing funding costs, tailored structures allow the bank to optimize ALM aspects of its balance sheet (maturity, gap, ...). Balance-sheet CDOs are created to remove (illiquid) credit risk from the balance sheet of the originating bank. Such operations allow the bank's income

stream to change from uncertain credit risk income to fees from the CDO originator.

Spread arbitrage is an additional motivation. CDO tranches are more liquid and trade at a lower liquidity margin than the pool's assets. The gain is distributed to the equity tranche and various involved counterparties in the structuring (investment banks, rating agencies, asset managers, . . .). CDOs with this purpose are called arbitrage CDOs.

Securitization has disadvantages for issuers in the sense that it reduces asset quality. Such operations are costly because of the legal fees, rating agencies, administrating costs, etc. The more complex the structure, the higher the costs. The high costs often require large-scale restructuring that is not cost efficient for small-size or medium-size transactions.

Investors are interested in structured products because of a potential higher rate of return tailored to their risk appetite. This is especially true for a risk-averse investor that prefers investing in high-rated issues (AAA–A). Firm issues of this quality are limited. Investing in a pool of securitized assets corresponds to investing in a miniportfolio. When these assets have low correlation with the existing investment portfolio, the portfolio becomes better diversified.

### 1.8.5 Other financial products

The above list of financial products is far from complete. Some popular financial products outside the equity, debt and derivative instruments are factoring, mutual funds, liquidity facilities and guarantees:

**Factoring:** Factoring is a type of financing whereby a company (seller) sells its accounts receivables from its debtors at a discount (the factor fee) to a third party called the factor or factoring company. It allows businesses to convert their accounts receivables immediately into cash without having to wait until the end of the payment term (typically 30 to 90 days). It is an off-balance sheet operation that is not considered debt or equity. The factoring operation can be done with (notified factoring) or without (confidential factoring, agency factoring) notification to the seller's debtors. In recourse factoring, the risk of non-payment is taken by the seller, whereas in non-recourse factoring the factor is responsible for tracking non-payments. In maturity factoring, the factor guarantees payment after a specific maturity to allow for a consistent and regular cash flow.

## 82 Bank risk management

In partial factoring, only a fraction of the invoices are outsourced to the factor.

**Mutual fund:** Mutual funds or managed funds are a form of collective investment. Money is pooled from many investors and professionally managed on their behalf. Mutual funds invest in equity, bonds, short-term money market instruments and other securities types, as described in the prospectus. Most funds are open for investors to sign in or out.

The net asset value of the fund is calculated as the total value of the fund divided by the total number of shares outstanding. The net asset value is published regularly on internet sites and/or newspapers. It allows relatively small investment amounts to be diversified.

**Liquidity facilities:** A liquidity facility is an agreement with a third party, usually a bank, to provide liquidities (e.g., ready cash) based upon certain conditions. Two common types of liquidity facilities are letters of credit and stand-by bond purchase agreements:

**Letter of credit:** A letter of credit (L/C) is a binding document that a client (e.g., importer) can request from his bank in order to guarantee the seller (e.g., exporter) the payment for the goods shipped. Letters of credit are used a lot in international trade transactions, e.g., deals between a supplier in one country and a wholesale customer in another. The parties involved are typically a beneficiary (seller, exporter, supplier) who is to receive the money, the advising bank of whom the beneficiary is a client, the issuing bank of whom the buyer (importer, wholesale customer) is a client, and the buyer that pays the goods and services.

Letters of credit are also often referred to as documentary credits, because payments are conditional upon the availability of documents as follows:

1. The conditions of sale are agreed and the letter of credit issued by the buyer is transferred to the beneficiary.
2. The beneficiary presents the stipulated documents (e.g., shipping document, commercial invoice, insurance document) to his advising bank and receives payment in return.
3. The advising bank then sends these documents further to the issuing bank and gets paid.
4. The issuing bank then presents the document to its client, who can then collect the goods and pay the bank.

Different types of letter of credit exist. A revocable letter of credit can be withdrawn or amended at any time by the buyer without agreement of the beneficiary. An irrevocable letter of credit can only be amended upon agreement of all parties involved. An advised letter of credit does not put any obligation on the advising bank to pay. When the letter of credit is confirmed, the advising bank will pay upon request of the issuing bank. When the letter of credit is guaranteed, the advising bank will pay upon request of the beneficiary.

A letter of credit can also be used when remarketing bonds. When a bondholder wants to tender a bond (e.g., because of adverse interest rate changes or reducing credit quality), a third-party trustee can draw from the bank on a letter of credit to pay the bondholder. If the remarketing agent (e.g., lead underwriter) is successful in remarketing the bond to a new bondholder, the purchase price is used to reimburse the bank issuing the letter of credit. If the remarketing agent is unsuccessful, the issuing bank becomes the new bondholder and the bond becomes a bank bond. By issuing the letter of credit, the bank takes the remarketing risk in return for a fee.

**Stand-by purchase agreement:** A stand-by bond purchase agreement is an agreement between a bank, the trustee, and the issuer under which the bank agrees to purchase the bonds tendered by a bondholder that have not been remarketed by the remarketing agent. It avoids, a.o., that the market price of the bond would drop or that the bond issuer gets liquidity problems because he needs to repay the debt.

Until drawn, liquidity facilities are conditional exposures and considered as off-balance sheet exposures. In a broader sense, letters of credit are conditional debt instruments that can be called when certain contractual conditions are met.

**Guarantee:** A guarantee provides protection to the creditor in the case of financial difficulties of the debtor. In the case of default or repayment problems of the debtor, the creditor calls the guarantor to repay the unfulfilled obligations of the debtor. In some cases, the guarantor has recourse on the debtor to get reimbursed for the money paid. Guarantees can be provided by relatives (in retail) or by professional institutions, like export credit agencies and banks, in exchange for a fee. Credit derivatives are a professional form of guarantee between financial institutions and professional investors.

Financial guarantors or monoliners are specialized insurance companies that guarantee firm or public debt. These insurers are typically highly

## 84 Bank risk management

rated, which allows the credit quality of the debt to be enhanced. In return for the credit enhancement, the monoliners charge a fee. Enhanced credit is interesting for debtors as it may reduce the total borrowing cost. In some countries, high-quality debt paper are eligible investments for a wider public of borrowers (e.g., pension funds) and can be subject to favorable tax regimes.

Guarantees provide a double protection to the creditor, who suffers only a default when both the debtor and guarantor default on their obligation.

Note that there exist many financial products tailored to the local needs of the customers and the local regulation. For each of these products, investors need to analyze the risk compared to the return. In the remaining chapters, the credit risk analysis is further described. Issuer and issue risk is analyzed by means of scoring systems (Chapter 2) and expressed by means of credit ratings (Chapter 3), for which rating models have become an indispensable tool (Chapter 4). Modern portfolio risk and bank capital regulation to calculate the risk of a portfolio of credits are discussed in Chapters 5 and 6. The bank failures listed in Table 1.5 confirm the necessity of adequate risk management techniques.

**Table 1.5** A selection of recent bank failures and crises [37, 56, 128].

### **Great depression:**

In October 24, 1929, the New York stock market crashed. In the years before the crash, the stock market boomed and the Federal Reserve did not take effective action to avoid the bubble. Depositors lost faith in their banks after the crash as banks were known to have significant stock market positions. The banking system was subject to bank runs: depositors “ran to the bank” to withdraw their funds in a cash payment. Although banks can be perfectly solvent, they may not have sufficient liquid assets to respond to a bank run. The 1930 banking crisis was a systemic event, beyond the capacity of the lender-of-last-resort to prevent it. Many borrowers defaulted during the crisis and weakened the banks, while the crisis itself was exacerbated by the contraction of credit due to the numerous bank defaults. In 1933, the federal deposit insurance was established in the US. The insurance fund protected depositors in the case of a bank failure and eliminated the causes for a bank run. The risk was transferred to the deposit insurance fund, who needed to regulate the banks.

### **UK banking crisis (1973–1974):**

Competition increased between banks in the supply of credit, following a new policy of 1971. Financial institutions specialized in lending for consumer durables were in financial distress. Different forms of assistance and a lifeboat operation prevented the collapse of about 30 banks and strengthened other weakened banks.

**Table 1.5** *continued***Failure of Bankhaus Herstatt (1974):**

The German bank Herstatt was active in the foreign exchange market and speculated on the exchange rate between US dollar and the German mark. After the collapse of the Bretton Woods system, the floating exchange rate regime made exchange rate risk a new issue. Wrong bets ended up in financial difficulties. Market rumors triggered a special regulatory audit, which revealed that open positions were far above the theoretical limit and amounted to a multiple of the bank's capital. Final losses were about 4 times the capital, when the bank was closed in June 1974 at noon. The bank had received payments in German marks, but the counterpart banks, that were expecting the corresponding US dollar payment in the afternoon, never received these payments.

The close down caused an important liquidity shock and substantial losses to the involved counterparts. On a global scale, the default caused an important disruption of the international payment system and the foreign exchange market. A concerted timely and effective intervention of international authorities avoided a widespread crisis. The concerns of regulators to avoid such situations gave birth to the Basel Committee on Banking Supervision (BCBS). The term "Herstatt risk" is still used today to indicate specifically the risk in foreign exchange settlements due to time difference.

**Spanish banking crisis (1978–1983):**

The banking industry was rigidly regulated in Spain during the 1960s: interest rates were regulated with floors on lending rates and caps on deposit rates, a quota system controlled the number of branches and the market was closed for foreign banks. The sector's profitability attracted new, inexperienced banks. The stable and prosperous macroeconomic situation of the golden 1960s did not seem to motivate a strong regulation.

Deregulations opened the market for more competition and changed the environment in which most banks were used to operate. The troubled macroeconomic conditions of the 1970s, with delayed impacts of the 1973 oil crisis, inflation, political uncertainty and reducing company sales weakened the banks. In addition, risk management was weak, with poor customer selection, inadequately high risk concentration, poor monitoring of the existing customers and a strong credit growth. Regulation focused mainly on monitoring leverage rather than risk: the amount of borrowed funds compared to own funds. These effects caused more than 50% of the commercial banks to end up in a severely financially distressed situation around 1980. Small institutions were hit first, larger ones followed. A large holding, Rumasa, that controlled 20 banks and other financial institutions was also affected, risking a systemic crisis.

The Spanish crisis was resolved by the creation of a vehicle that took over distressed banks, while losses were absorbed by the shareholder's equity and were further bailed by government capital. The 1985 Spanish regulation reviewed existing rules for provisioning and doubtful assets. A minimum equity/weighted assets ratio was imposed, where assets are divided in 6 classes and weighted as a function of their risk level. It resulted in a more stable financial system, that still observed some failures of very small banks in the early 1990s and the collapse of Banesto in 1993, which was the fourth largest bank in terms of deposits.

**US savings and loan crisis (1982–1995):**

Savings and Loans (S&L) institutions developed an important activity after 1929. These institutions collected short-term deposits to finance long-term fixed-rate mortgages.

**Table 1.5** *continued*

Mortgages were low-risk investments and the interest rate margin was important because of regulatory maximum deposit rates. The crisis starts in the 1980s, after the important macroeconomic changes in the troubled 1970s. Regulatory restrictions resulted in a fragmented banking industry with about 20,000 financial institutions, many of them inefficient and competitive.

With effective interest rates on a mortgage portfolio around 9%, inflation at 12% and government bond rates at 11%, it became more and more difficult to raise funds via deposit collection. Investors preferred money market funds above savings accounts. Non-depository financial institutions offered more attractive financial products to customers. This process of disintermediation eroded the bank's interest margins and profitability. When the maximum interest rate on deposit accounts was abandoned, S&L institutions regained access to funding, but had to invest in riskier assets to maintain their interest rate margin.

The funding problems already weakened the financial health of the S&L sector. Weaker institutions failed to adapt to the changed environment. Moreover, riskier investments further weakened the solvency. Developing countries were hit more by the economic downturn than developed countries. The Mexican default of 1982 and the default of many other developing countries and their public sector entities, deteriorated further the financial strength of the S&L institutions. Many banks that failed were also investing in speculative real estate projects, which are highly unreliable in weak economic circumstances. Changing tax legislation on mortgages eroded it further.

A run on thrifts in Ohio and Maryland caused insolvency of state-chartered deposit insurance agencies in 1985. Large losses in Texas and elsewhere, caused the bankruptcy of the federal insurer (Federal Savings and Loan Insurance Corporation). In 1986, 441 institutions became insolvent and 553 others had capital ratios below 2% (compared to the required 5.5% in the 1983 US International Lending and Supervisory Act). About 50% of the institutions were in severe financial distress.

In order to prevent a bank run, deposits were guaranteed by the federal state, who also bought other distressed S&L institutions, cured and sold them to other banking groups. In a limited number of cases, direct assistance to the banks was given. During the subsequent US crisis that started in the 1990s, about 3000 banks failed. In about 50% of the cases, the FDIC intervened in some way in the resolution of the failed bank. The estimated fiscal resolution costs amounted to 2.1% of the annual GDP. The crisis led to important changes in the banking legislation and the banking industry itself. By the end of the crisis, in the 1990s, about half of the existing institutions had survived.

**Failure of Continental Illinois National Bank (1984):**

Continental Illinois Bank was the 7th largest commercial bank in the US with total assets exceeding US\$40 bln. It was the most important bank in the Midwest, that had grown significantly, a.o., thanks to its successful commercial and industrial loan portfolio. The growth was financed by jumbo certificates of deposits, Eurodollar deposits and short-term non-deposit liabilities. The restrictive Illinois bank law prohibited the bank from having branches outside the state and was limited to raising deposits in its origination base in downtown Chicago.

The bad economic conditions of the late 1970s and early 1980s also hit the bank. Confidence in the bank was damaged in 1992, when it was identified as the purchaser of US\$1 bln loans from a failed bank. Asset quality became more and more questioned by analysts and rating agencies, who downgraded the bank. Because of its high exposure to developing countries, the bank declared an additional amount of 400 mln non-performing

**Table 1.5** *continued*

loans, totalling up to 3.2 bln of non-performing loans. Most of these sour loans had a Latin American exposure.

In May 1984, the bank faced a bank run by institutional investors. In contrast to classical deposits, institutional investors were not protected by the insurance fund. Such investors provided funding on condition of confidence in the bank's health. When this confidence faded, the bank lost 10 bln of deposits in less than two months, the bank had to borrow massive amounts from the Federal Reserve to cope with its increasing liquidity problems. When more deposits were withdrawn, the FDIC announced a rescue plan and the bank was temporarily nationalized. Deposits and bondholders were guaranteed.

The bank failed due to liquidity problems. Its restrained funding base made it more sensitive to funding from unprotected institutional investors. When these withdrew funding, the bank was not able to liquidate its assets at a suitable speed. When the bank was closed, its net worth was still positive and equal to US\$2 bln.

### **Norwegian banking crisis (1988–1993):**

After the second World War, the banking industry was strongly regulated until the 1980s. The banking industry consisted of a very small number of national banks and a large number of small, regional banks. The deregulation of the Norwegian banking sector in 1984–1985 removed quantitative controls on bank lending and the cap on interest rate lending. Later, capital regulation was relaxed and regulatory inspections reduced; while the tax regulation on interest rates was also changed.

Banking became more competitive and an important number of banks opted for an aggressive growth strategy. Credits were easily granted as observed by a growth of 12% of credit volume granted between 1984 and 1986. The boom stopped and the drop in international oil prices put the economy in a sharp recession, while real estate prices dropped significantly. The economic crisis resulted in a credit risk crisis for the banks, with loan losses peaking up to 3.5% of the Gross Domestic Product.

Amongst the smaller banks, some of them got into financial difficulties and most were saved by capital injections from the deposit insurance system and mergers with larger, solvent banks. Only one, new bank that failed was liquidated, the rescue operations were considered less costly for the insurance funds of the commercial banks and savings banks guarantee funds.

When the three major banks reported significant losses in 1991, the insurance system was not large enough to cure at least one and the government intervened to avoid a systemic collapse. Capital was injected directly and indirectly into the banks with too low equity for the current and upcoming Basel I regulation. As conditions for the capital investments, existing shareholder capital was used to absorb the losses, banks were reorganized, and management was replaced. Liquidity was provided on a case-by-case basis.

Compared to other crises, no specific "bad bank" was created with problem loans, no explicit guarantees were given by the state to avoid healthy banks relaxing their strategies and no important industry restructuring was done. Gross fiscal costs of the rescue operations were estimated to be about 3% of GDP.

### **Failure of Bank of Credit and Commerce International (1991):**

The Bank of Credit and Commerce International (BCCI), founded in 1972, was a bank with a very complex structure and main shareholders in Abu Dhabi. The holding head-office was incorporated in Luxembourg, with two main subsidiaries incorporated in Luxembourg and the Cayman Islands. Those subsidiaries had branches in more than 70 countries.



**Table 1.5** *continued*

Regulators already recognized that the complex and opaque structure did not facilitate effective banking supervision. Luxembourg authorities were in principle the lead regulator, but the operational headquarters and 98% of the business fell outside its jurisdiction. Local regulators were responsible for the supervision of the local branches, but unable to supervise the bank as a whole. The bank itself showed rapid growth, for which one believes now that a scheme of deception was set up from the beginning. Lending losses were concealed, fictitious loans were created that generated substantial revenues, deposit liabilities were incorrectly recorded, proprietary trading was not done with own funds, but with depositor's money and trading losses were covered by new fictitious loans.

The rapid growth and opaque structure caught the attention of different supervisors involved, who established an eight-nation "College of Regulators" in 1987. Meanwhile, market participants attributed the losses of BCCI to incompetence rather than to fraud. Concerns of the evidence of fraud resulted in ongoing discussions between the bank's regulators, auditor and shareholders. The auditor reported his findings on the inaccurate financial statements and endemic fraud in June 1991 to the UK supervisor. The college of regulators gathered and decided to close the bank with a timing of minimal market disruption. BCCI was closed on July 5, just before the opening of the New York stock markets. Depositors received money from the deposit insurance funds, creditors received some of their money after a long process of litigation. Regulators reacted to this fraud case by tightening international standards, rules and responsibilities for home and host regulators, better international communication between regulators, and limitations on complex structures that hindered effective supervision.

**Failure of Bank of New England (1991):**

The Bank of New England was regionally active in the Northeast of the US, with an aggressive growth strategy on commercial real estate that represented 30% of the loan portfolio. It totaled US\$32 bln of assets in 1989.

The collapse of the real estate market set up the bank with a high amount of non-performing loans. At the end of 1989, these loans amounted up to 550 mln or 2.2% of the total loan portfolio. Real estate portfolio may exhibit rapid loss growths. At the year-end of 1990, the bank had 3.2 bln of non-performing loans, about 20% of the total portfolio. An additional projected Q4 loss of 450 mln was declared on Friday, January 4, 1991 and made the bank technically insolvent. During the weekend, depositors withdrew more than 1 bln of funds, much of the money was withdrawn via automated teller machines. The FDIC assumed the bank on January 6 and created 3 bridge banks, agreeing to pay off all depositors, including those with exposures exceeding US\$100,000. The total bailout cost for the FDIC amounted to 3.2 bln. Afterwards, regulation was adjusted such that the FDIC was prompted to choose the least costly resolution method.

**UK small banks crisis (1991–1993):**

The smaller and medium-sized UK banks were specialized mainly in lending to specific geographic areas, industry sectors and/or ethnic/religious groups. Property lending was a main activity. The assets were financed mainly by wholesale funding, a.o., from US and Japanese banks.

The banks were operating well above minimum target capital ratios, but were not well diversified. Many banks that failed later, observed high credit growth after the mid-1980s. During the UK recession, banks observed pressure on both parts of their balance sheet: problems loans with falling collateral and difficult funding.

**Table 1.5** *continued*

In the late 1980s, the housing market in the United Kingdom boomed because of tax relief on mortgage interest, the diversion of personal savings after the Great Crash (Friday, October 16, 1987), and the competition amongst UK banks. The collapse of the boom results in a severe reduction of the collateral in mortgage loans. Whereas in normal circumstances, the real estate value exceeds the loan value, resulting in an almost net zero credit risk for banks; banks have a net credit risk when housing prices decrease below the loan value. Such loans are called negative equity loans.

When foreign banks became increasingly concerned about the length and severity of the UK recession, they withdrew more than 25% of their UK bank investments from 1990 till 1991. The liquidation of BCCI further increased the flight to quality and put more pressure on the bank's balance sheets. During the next three years, about a quarter of the hundred smaller banks failed in some way: they entered into administration or liquidation, their banking license was revoked or they received liquidity support. In the beginning of the crisis, regulators did not consider failures of small institutions as a systemic threat. When the crisis persisted and more banks ran into difficulties, the Bank of England provided liquidity support to avoid the crisis spreading further.

#### **Swedish banking crisis (1991–1994):**

A similar scenario happened in Sweden. Due to strict regulation on lending, interest rates and exchange rates, banks operated in an environment with low competition. Finance companies, founded in the 1980s, provided a competitive alternative for firm and household financing, but were not regulated because they did not take deposits. Regulation was mainly legal compliance oriented and capital requirements were at most 8% for the most risky investments. Deregulation, aggressive credit granting policies followed by a recession and a real estate bubble weakened first the finance companies. Their weakened position was not seen as a threat to the financial system, but their troubles cascaded into the banks that provided significant amounts of funding to these finance companies.

The loan losses reached peak levels of 3.5% and 7.5% in 1992, while real estate prices collapsed by 35% and 15% in the two subsequent years.

Two of the six largest Swedish banks needed support in 1991 to avoid the crisis spreading. Government intervention was also motivated by the target 8% capital level required by Basel, which is believed to be a major reason for early government intervention and relatively low resolution costs.

Bad assets were placed in separate asset management companies and support was given, under legal requirements, to weakened banks even when existing shareholders opposed. It discouraged healthy banks from relaxing existing risk management and capitalization policies. The crisis was resolved quickly in 4 years and the total resolution cost is estimated to amount to 2% of the Gross Domestic Product.

#### **Swiss banking crisis (1991–1996):**

The Swiss banking industry counts a few big, international universal banks, cantonal banks that focus on domestic retail banking and are (in part) owned by the Swiss cantons, regional banks active mainly in domestic retail banking, Raffeisen banks that are credit co-operatives active on the mortgage lending market in rural areas and private banks active mainly in wealth management.

The main driver for the banking crisis in Switzerland was a collapse of a real estate bubble combined with an unusually long recession after a decade of increasing housing prices and economic expansion. Asset quality was weakened, while funding became more

**Table 1.5** *continued*

difficult and expensive due to disintermediation, when deposits were withdrawn in favor of investments in bonds, equities and mutual funds. The crisis started in 1991 and lasted till 1996, loss estimates for this period from the Swiss regulator sum up to 8.5% of the credit granted. In particular, large, regional and cantonal banks absorbed important losses. Whereas the large banks were sufficiently diversified and were sufficiently profitable, regional and cantonal banks easily fell into financial distress. A medium-size regional bank (Spar + Leihkasse Thun) was closed by the regulator in 1991, with depositor losses because assets could no longer cover the liabilities. In the resulting crisis, the regulator acted promptly by a rapid closure of insolvent banks, by creating a task force to organize take-overs of nearly insolvent banks, by stimulating weak banks to merge with stronger banks and by financial assistance.

Except for some cantonal banks, no financial assistance was granted, which limited the cost of the crisis to less than 1% of the gross domestic product. Big banks took over many smaller banks, about 50% of the institutions disappeared during the crisis, while only one bank was liquidated.

**Japan banking crisis (1994–2002):**

In 1990, the Japanese banks had become the largest in the world. They had significant assets in foreign countries, e.g., in Europe and the US, where they were an important foreign player. The first signs of inflation in Japan appeared in 1989, interest rates were increased and the stock market index lost 50% of its value.

No major bank failures occurred in Japan until 1994. Smaller banks failed, but no specific action for the financial system was taken, also because macroeconomic and financial conditions were expected to improve. Banking supervision and regulation was conducted by applying the convoy system, not to destabilize the viability of the weakest banks. The Deposit Insurance Corporation (DIC) could intervene either by closing down a failed bank and refund deposits up to ¥10 mln per depositor or via financial assistance to rescue the failed bank. Contrary to expectations, the financial sector did not improve in subsequent years.

The crisis started in 1994. Two urban credit co-operatives, Kyowa Credit and Anzen Credit, failed in December. To avoid a disruption of the financial system, a rescue plan was chosen to intervene. As the rescue plan exceeded the legal limit of the Deposit Insurance Corporation, the business of the failed institutions was taken over by a new bank, subscribed by the Bank of Japan (50%) and by a collective participation of private institutions (50%); while the DIC provided additional financial assistance. It was the first such rescue operation in Japan since 1927. The largest bank, Sumitomo Bank, declared a loss in 1994; it was the first time in half a century that a large Japanese bank declared a loss. It was illustrative of the financial situation of Japanese banks in the mid-1990s.

In summer 1995, three other banks failed, two of them were rescued in the same way using the *hougacho* approach of collective participation. The failure of the third bank, Kizu Credit Cooperative, was too large with losses exceeding ¥100 bln. It was rescued by the Resolution and Collection Bank, after a change of the legal framework that removed the DIC's pay-off limit. Jusen companies were historically active in mortgages and had become active in real estate development lending during the 1980s without a good risk management expertise on the latter asset class. Huge losses up to JPY 6.4 tln (trillion) were reported in 1995 and the government needed to intervene, for the first time with taxpayer's money.

The crisis continued 1997, with two important banks (total assets of about ¥15 tln and ¥10 tln) fail, mainly because of real estate exposures that turned sour after the bubble

**Table 1.5** *continued*

and because of increasing funding costs resulting from rating downgrades. The banks were rescued, by capital injections and nationalization later or by transfer of the business to another bank. In autumn, Sanyo Securities, a medium-size clearing housing, filed an application to start reorganization under the Firm Reorganization Law. Securities houses were supervised by the Ministry of Finance and were outside the scope of deposit insurance. Supervisors judged the impact first as rather limited, but the psychological impact on the interbank market resulted into a liquidity shock and the insolvency of Yamaichi Securities, a top-four securities house. To maintain financial stability, the authorities intervened to provide liquidity and guarantee liabilities. Yamaichi Securities was declared bankrupt in 1999, after an organized close-down of activities.

In 1998, legislation was adapted to allow further the use of public, taxpayer's money to deal with the financial crisis. A financial crisis committee was established and a capital injection of ¥1.8 trillion was made, but failed to have a positive market impact as it was considered too small. The Long-Term Credit Bank went bankrupt, which was the largest bank failure in the Japanese history. When a bail-out merger failed, the "Financial Reconstruction Law" followed that allows an orderly wind-down of the activities by a nationalization. Later, the cured bank was bought by private investors.

In subsequent years, the Japanese crisis was actively managed. The Financial Reconstruction Committee was set up to apply new measures to build a safety net. It was given supervisory power and inspection authority via the Financial Supervisory Agency (FSA) that took over supervisory tasks of the ministry of finance. Financial resources were doubled from ¥30 to 60 tln. A capital injection of ¥7.5 tln reinforced the 15 major banks. In addition, an infrastructure was created to remove bad loans from the balance sheets of Japanese banks and a further consolidation was catalyzed.

The Japanese crisis had an important impact: many banks stopped their international expansions, while 180 deposit-taking banks were dissolved. The cost of the non-performing loans amounted to ¥102 trn, which was about 20% of the Gross Domestic Product. Major causes for the crisis were the problem of non-performing loans, weak capitalization and weak economy. Non-performing loans weakened the bank's asset quality and the resulting credit contraction discouraged firm investments and reduced economic growth.

In addition, market discipline and information about asset quality was low in the beginning of the crisis and provisioning was inadequate for various reasons. The simultaneous appearance of these causes resulting in a long crisis that was resolved by addressing the non-performing loans problem and strengthening bank capitalization by the use of public funds.

#### **Bankruptcy of Barings Bank (1995):**

Barings Bank, the oldest London merchant bank (1762), absorbed more than unreported losses of 2 years from a derivatives trader. The head trader, Nick Leeson, was based in Singapore and made unauthorized trades resulting in huge losses that were hidden from the bank's senior management. The devastating earthquake of January 1995 in Kobe, Japan, had an important impact on the Nikkei 225 stock index. It caused the index to move outside its normal range, beyond the expectations of the trader, who had risked significant amounts on the assumption that the index would not move materially. The head trader had control over both the front and back office, which allowed him to falsify trading entries and hide losses. To cover past losses, he increased the bets and disguised the trades as customer positions.

## 92 Bank risk management

**Table 1.5** *continued*

The violation of the separation principle of front and back office functions was the primary cause of the bank's failure. The operational risk of internal fraud was not managed by the bank's organization that failed to catch the unauthorized trades and to notice the resulting accumulated losses. The bank went bankrupt in 1995 and was taken over by Internationale Nederland Groupe.

**Failure of Peregrine Investment Holdings (1997):**

This leading investment bank failed because of concentration risk: it made a large loan to the Indonesian taxi-cab operator PT Steady Safe of USD 235 million, up to a quarter of the bank's equity. The bank failed due to the Asian crisis of 1997 that resulted in a high loss for the insufficiently diversified bank.

**US subprime lending crisis (1998–2001):**

Subprime lending programs target customers with weak credit histories or limited debt repayment ability. Such loans are much more risky than standard loans, but Basel I capital rules did not impose higher capital for the subprime loans than to other loans. As a result, subprime lending institutions were compliant with capital rules, but were effectively more weakly capitalized.

In 1998, it was discovered that Bestbank hid massive losses on subprime credit card exposures and the bank was closed, costs for FDIC amounting to US\$222 mln or 95% of the assets. Two other institutions, National Bank of Keystone and Pacific Thrift and Loan, fail with resolution costs amounting up to 71% and 33% of the assets, respectively. Superior Bank failed in 2001, as a result from optimistic valuation of tranches securitized subprime loans. Losses amounted to 28% of the total assets.

Regulation was changed after the failure to align capital with the risk of such positions. The crisis was due to hidden credit losses on subprime loans and unadjusted regulation.

## 2. Credit scoring

---

### 2.1 Introduction

A sound credit risk management is built upon a good-quality portfolio of performing assets. The pricing of the loans has to reflect the risk. A good selection strategy aims to avoid high losses. Credit scoring is a credit risk management technique that analyzes the borrower's risk. In its early meaning, "credit scores" were assigned to each customer to indicate its risk level. A good credit scoring model has to be highly discriminative: high scores reflect almost no risk and low scores correspond to very high risk, (or the opposite, depending on the sign condition). The more highly discriminative the scoring system, the better are the customers ranked from high to low risk. In the calibration phase, risk measures are assigned to each score or score bucket. The quality of the credit scores risk ranking and calibration can be verified by analyzing *ex-post* observed credit losses per score. Credit scores are often segmented into homogeneous pools. Segmented scores are discrete risk estimates that are also known as risk classes and ratings. Ratings will be discussed in the next chapter.

In the past, credit scoring focused on measuring the risk that a customer would not fulfill his/her financial obligations and run into payment arrears. More recently, credit scoring evolved to loss and exposure risk as well. Scoring techniques are nowadays used throughout the whole life cycle of a credit as a decision support tool or automated decision algorithm for large customer bases. Increasing competition, electronic sale channels and recent banking regulation have been important catalysts for the application of (semi-) automated scoring systems.

Since their inception, credit scoring techniques have been implemented in a variety of different, yet related settings. A first example is credit approval. Originally, the credit approval decision was made using a purely judgmental approach by merely inspecting the application form details of the applicant.

## 94 Credit scoring

In retail, one then commonly focused on the values of the 5 Cs of a customer [133, 475]:

**Character:** measures the borrower's character and integrity (e.g., reputation, honesty, . . .)

**Capital:** measures the difference between the borrower's assets (e.g., car, house, . . .) and liabilities (e.g., renting expenses, . . .)

**Collateral:** measures the collateral provided in case payment problems occur (e.g., house, car, . . .)

**Capacity:** measures the borrower's ability to pay (e.g., job status, income, . . .)

**Condition:** measures the borrower's circumstances (e.g., market conditions, competitive pressure, seasonal character, . . .).

Note that this expert-based approach towards credit scoring is still used nowadays in credit portfolios where only limited information and data is available.

The early success of application scorecards drew the attention of the academics and researchers to develop advanced statistical and machine-learning techniques that apply a wide range of explanatory variables or characteristics. An application scorecard then assigns subscores to each of the values of these characteristics. These subscores are determined based on the relationship between the values of the characteristics and the default behavior, and are aggregated into one overall application score reflecting the total default risk posed by the customer.

An example of an application scorecard is given in Table 2.1. Consider a new application of a customer with age 35, income 12,000, and residential status with parents. Given the above scorecard this customer is assigned 330 points. These points are then compared against a cut-off and a credit decision is made. For example, when assuming a cut-off of 300 (400), the above loan is granted (rejected). When the score of a customer is close to the cut-off, it may be an indication that the scorecard is very unsure as to whether to label the customer as good or bad. This is why one can define a grey zone around the cut-off, which will require further (human) investigation for customers falling into that region.

This chapter is organized as follows. section 2.2 discusses the use of scores during different stages of the customer cycle, while section 2.3 compares scoring functions based on their characteristics concerning risk type, risk entity and the score source. Credit bureaus are a popular external reference source for scoring and are discussed in section 2.4. The concept

**Table 2.1** Example application scorecard: a customer with age of 35, income of 12,000 and residential status with parents is assigned a total score of  $120 + 140 + 70 = 330$  points.

Characteristic	Range	Scorecard points
Age	Up to 30	80
	30–40	120
	>40	150
Income	Up to 10,000	50
	10,000–100,000	140
	> 100,000	170
Residential status	Owner	130
	Tenant	100
	With parents	70

of overruling or overrides is reviewed in section 2.5. The different business purposes of credit scoring are reviewed in section 2.6. section 2.7 concludes this chapter with a critical review of the limitations of scoring systems.

## 2.2 Scoring at different customer stages

Being first introduced as a handy tool for underwriting retail credit, such as residential mortgages, credit cards, installment loans, and small business credits; credit scoring is nowadays being used to administer and follow-up default risk across the entire credit portfolio of a financial institution covering firms, sovereigns, local authorities, project finance, financial institutions, . . . These credit scoring models are no longer solely used for credit approval, but also in other contexts such as pricing, provisioning, regulatory and economic capital calculation, securitization, as will be explained in the next chapters.

Given the widespread success of application scoring in today's credit environment, financial institutions also started using credit scoring techniques on a range of other business objectives. Application scoring evaluates the risk of the borrower at the moment of credit granting. In the banking business, it is also important to follow the risk of approved transactions in the banking book and to monitor the status of the approved loans during their performant lifetime. When a loan becomes delinquent, collection scoring supports decisions and updates risk parameters. Before a loan is applied,



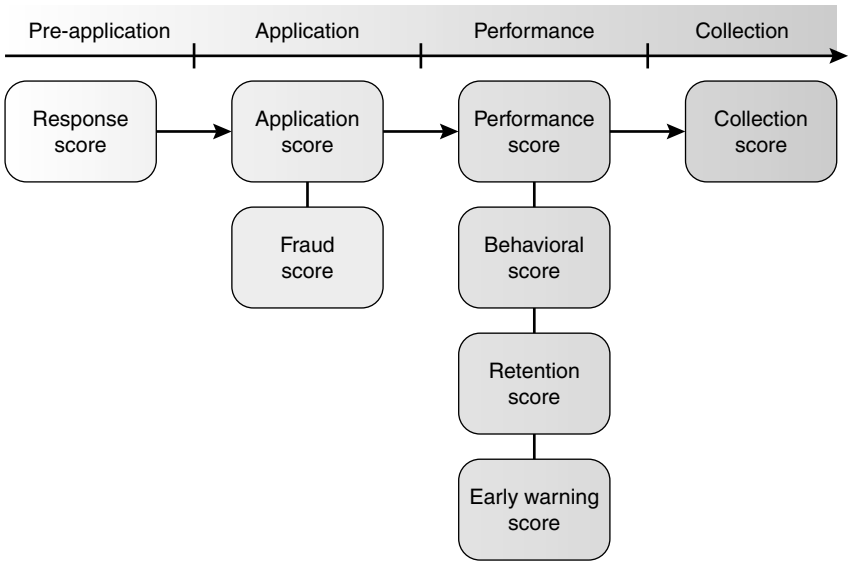

**Fig. 2.1** Overview of different scoring systems applicable during the different stages of the loan and customer. The combined information is used for profit scoring.

marketing campaigns need to address potential customers. An overview of scoring techniques through the different customer stages is given in Fig. 2.1.

### 2.2.1 Marketing score

Stiff competition from various financial institutions that offer similar products (e.g., credit cards and mortgages), has changed the market from a lenders’ market to a buyers’ market. It is the customer who decides which offer to take up, rather than the lenders deciding whether to extend an offer. In these conditions of a saturated consumer lending market and falling take rates, there is an increasing need to assess whether a customer is most likely to accept a variant of a financial product. Each accepted offer from a good customer means expected profit to the financial institution.

Marketing becomes an important pillar of the bank’s strategy and its success. Customer base growth and new product developments will improve the bank’s total assets and income. Successful marketing campaigns target the “right” product to the “right” customer. Response scoring identifies the probability that a potential customer will react to a marketing campaign, e.g., a direct mailing for a new product. Acceptance scoring goes one step further and assesses the probability of a customer accepting a variant of a financial

product or an offer [33, 436, 502]. Classical elements of a marketing score are the four Ps [153, 322, 372, 458, 459, 484] that define the marketing mix:

**Product:** Specifications of the offered services and their correspondence with the (potential) customer's needs.

**Pricing:** Price setting, including promotions, discounts, . . .

**Promotion:** Advertising, publicity, personal selling, brand, product and company recognition.

**Place:** The channel via which the banking products or services are sold, e.g., density of a retail network, internet-banking, specificity of the customer group. It may also refer to placement, the "physical" distribution to the customer.

Other marketing variables are satisfaction of other people, relationships and competition. The classical marketing variables can be augmented with variables for repurchase behavior (recency, frequency and monetary) and risk management variables. For cross-selling applications, the internal knowledge of the customer resulting from the risk management databases provides very useful information for targeting creditworthy customers.

The marketing scores aim to reduce the cost of customer acquisition and to minimize customer inconvenience and dissatisfaction. The marketing campaigns are oriented towards a limited number of people with good profit potential that receive a score above the threshold. These people are prospective, potentially new customers and/or existing customers.

### 2.2.2 Application score

Application scoring systems summarize all applicant information into one overall score measuring the creditworthiness of loan applicants [475]. The application scores are considered to be key inputs in deciding whether a new credit should be granted or not. Based upon the information available at the time of application, the score gives the probability of repayment problems. High scores indicate creditworthy customers and hence credit should be granted, whereas low scores indicate potentially bad payers that should be denied credit. A simple example of an application scorecard is given in Table 2.1. When the customer has a good score that exceeds the cut-off or threshold value, the loan is granted, otherwise not. The cut-off level depends on the bank's strategy, risk appetite and pricing. It defines the risk that the bank wants to take. In some cases, one defines an intermediate score range where the approval outcome results from an additional human expert

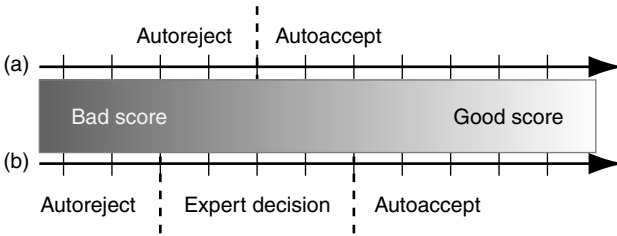

**Fig. 2.2** Application score systems: a) in fully automated application score systems, the application is approved if the score exceeds the threshold value or cut-off; b) in semiautomated systems, the application is automatically approved or declined for high and low scores. For intermediate scores the decision follows from an additional human expert analysis.

judgment as indicated in Fig. 2.2. For approved loan applications, the price and amount of the loan can be made dependent on the actual level of the score. In a risk-based pricing environment, the price of the loan depends on the risk of the customer. Lower amounts will be given to higher-risk customers to reduce concentration risk on low-quality borrowers. Applicants with scores below the threshold represent too high a risk and are not accepted.

A first advantage of using automated application scorecards is the time reduction in processing new applications. Applications can be screened and scored in real-time, which is very important in today’s highly competitive credit market. This can be illustrated by the increasingly important role played by the internet and e-commerce in this context, which makes real-time scoring and credit evaluation a necessity. Another advantage of using automated scorecards is the decision consistency. Rather than relying on an *ad-hoc* subjective evaluation of a credit expert (e.g., based on interpretation of the 5 Cs), the decision can now be motivated by using an enterprise-wide credit approval policy based on the scorecard. Finally, by using the scorecard, targeted questions can be asked during the application process, thereby preventing the customer from having to fill in the entire application form with irrelevant details.

It is important to remark that there is also a legal and ethical issue involved in granting credit to customers. The Equal Credit Opportunities Act (1976) and regulation B in the United States prohibit the use of characteristics such as gender, marital status, race, whether an applicant receives welfare payments, color, religion, national origin and age in making the credit decision [122]. Furthermore, when rejecting an applicant for credit, he/she must be given specific reasons to motivate the decision. Ethical considerations

may prevent the use of certain variables for scoring, data mining and credit decisions.

### 2.2.3 Fraud score

Fraud scoring comes in many flavors. A first example is application fraud scoring in which one estimates the probability that credit applicants have provided fraudulent information at the time of application [179]. Other examples are claim fraud scoring in which one rank orders insurance claims based on the probability of being fraudulent [503], and credit card fraud scoring that aims at detecting fraudulent credit card transactions. Fraud scores need to be monitored frequently to adapt them timely to new fraud mechanisms.

A common problem in fraud scoring, which distinguishes it from traditional credit scoring, is that it is typically very hard to determine *ex post* what constitutes a fraudulent transaction. Whereas in credit scoring one can easily see which accounts turn bad by observing and counting the number of days in payment arrears, in fraud scoring it is less evident to qualify an insurance claim as fraudulent or a credit application as containing fraudulent information.

### 2.2.4 Performance score

Performance scoring in its most general form is used to evaluate the risk of an existing customer during its performance stage. The performance score often uses a fixed time horizon in the range of one to multiple years. The prediction horizon of 12–24 months is often much smaller than for application scoring. This period is called the performance period (Fig. 2.3). Because performance scoring is applied on customers, more detailed information is available on a longer time history than for application scoring on new applicants.

The goal of performance scoring is to monitor the existing portfolio, its future performance and losses. The results are used for provisioning, regulatory and economic capital calculations. Higher-risk borrowers are detected and put on a watchlist before they possibly become delinquent and default. Losses can be reduced by active risk measurement like customer assistance, debt restructuring, but also by reducing credit limits of revolving credits and taking collateral. The recent Basel II capital accord puts a high emphasis on internal performance scoring systems to monitor the risk with a default prediction horizon of 1 year. Performance scores are also useful information for collection, profit and marketing scores.

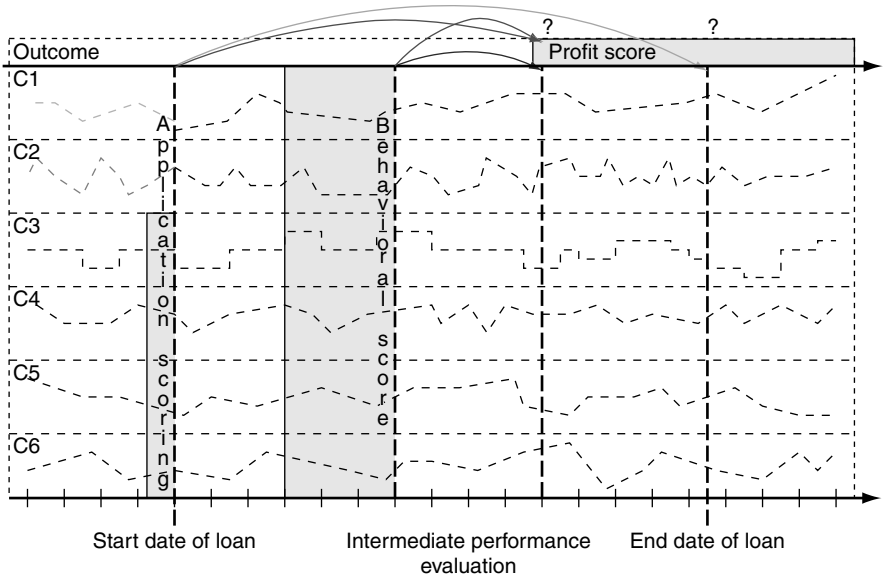

**Fig. 2.3** Application, behavioral and profit scoring. Application scoring takes a snapshot of the counterpart at the beginning of the loan to predict the outcome at the end of the loan. Behavioral scoring monitors the recent evolution and behavior of the counterpart to predict its evolution on a shorter time horizon, like other performance scoring techniques. Because the counterpart has become a customer, more information or characteristics (C) are available on a longer time horizon. Profit scoring measures the risk along a much longer time horizon. The outcome is not measured on a discrete time moment but on a time interval. It is evaluated several times during the customer relationship using increasingly more information.

Unsuccessful firms have been defined in numerous ways in the literature and the terms “financial failure”, “business failure”, and “bankruptcy” are often used interchangeably although their meaning may formally differ [14, 150]. A common theme is that such firms cannot pay liabilities that have become due and that this results in discontinuity of the firm’s operations. The common assumption underlying these models is that key macroeconomic indicators (such as inflation, interest rates, unemployment, ...) together with firm characteristics (such as competition, management quality, market share, ...) are appropriately reflected in the firm’s financial statements. The future financial status of the firm can then be predicted by using data originating from these statements and advanced credit scoring models [14, 327, 379]. One very popular bankruptcy prediction model is Altman’s z-model introduced in 1968 [12, 14]. Using a sample of 66 manufacturing firms, a linear discriminant using five financial ratios was constructed as follows:

$$z = 0.012x_1 + 0.014x_2 + 0.033x_3 + 0.006x_4 + 0.999x_5, \quad (2.1)$$

where  $x_1$  = working capital/total assets,  $x_2$  = retained earnings/total assets,  $x_3$  = earnings before interest and taxes/total assets,  $x_4$  = market value equity/book value of total debt,  $x_5$  = sales/total assets. Higher z-scores indicate financially more sound firms. For example, a z-score  $> 2.99$  indicates that the firm is situated in the safe zone, a z-score between 1.8 and 2.99 that the firm is in a grey zone, and a z-score lower than 1.80 that the firm is in the distress zone. The z-score model was later extended and refined in various ways and is still very popular nowadays [14, 15]. Developing accurate bankruptcy prediction models is a topic that is still being intensively researched.

For retail customers, there is an important difference between the information available for new applications and existing customers of which account and transaction information is used in behavioral scoring. Such information is highly predictive and improves the discrimination quality of the score. For larger counterparts, companies, banks and sovereigns, the difference between application and performance scores is more vague. Official financial statements and accounts for these counterparts are available via financial reports. Such counterparts have a more active debt management and apply more regularly for new loans. The main differences between application and performance scoring are the prediction horizon, the lack of an established customer relation and the quality of the customer information. The differences for application, performance and profit scoring are depicted in Fig. 2.3.

### 2.2.5 Behavioral score

Behavioral scoring analyzes the risk of existing customers based on their recently observed behavior. In most cases, one predicts the default risk that the customer would default within one year. Application scorecards provide scores measuring the risk of default at the start of the loan, given all application characteristics available. Once credit has been granted, banks can subsequently start to monitor the repayment and financial behavior of their customers. In other words, the risk of default can be reconsidered taking into account all recent customer behavior that can be observed, e.g., checking account balance, changes in employment status, missed payments, new bureau information, . . . In behavioral scoring, all this behavioral information will be accumulated into a behavioral score reflecting the probability that an acquired customer will default or not in the near future. Whereas application scoring is considered to be static since it takes two snapshots of the customer at different points in time (beginning of the loan and the default observation

point), behavioral scoring is much more dynamic since it takes into account the behavior of the customer during the observation period [476].

The performance period is typically between 12 to 24 months and the same default definition as for application scoring is adopted. The observation period is typically between 6 to 24 months depending on the volatility of the customer behavior (Fig. 2.3). During this period, several behavioral variables may be observed, assumed to be related to the risk of default; examples are: checking account balance, employment status, bureau score, number of credits, . . . These variables may then be summarized using various operators, e.g., maximum, minimum, average, relative trend, absolute trend, most recent value, . . . , yielding derived variables such as minimum checking account, relative trend in bureau score, average utilization during last 6 months, maximum number of previously missed payments, most recent income, . . . Note that when summarizing trends in variables, one must be well aware of the seasonality effects that may be present, e.g., account balance towards December, 31st may be different from, e.g., that towards April, 30th because of end-of-year effects (bonuses, thanksgiving, holiday period, . . .). It is clear that in this way many more variables become available than in an application scoring context and input selection is going to be very important, as will be explained in book II.

Behavioral scores are mainly used in a retail context. They have proven to be very useful for credit limit management, provisioning, capital calculations. They are also used for collection and marketing scores. Many financial institutions use behavioral scoring nowadays. The behavioral scores are recalculated at frequent time intervals (e.g., weekly, monthly) in order to capture the changing dynamics in a customer's behavior timely. Figure 2.4 provides an example of a behavioral scorecard combined with application scores. The first score is given by the application scorecard. When sufficient customer information is available, the behavioral scorecard is applied to monitor the existing customers portfolio and to improve other scores.

### **2.2.6 Early warning score**

Early warning systems aim to early detect potential crises with counterparts. These counterparts are put on a watchlist for closer inspection and follow-up. Early warning systems make use of macroeconomic and accounting information, but also market information from equity, bond and derivative prices. Market information has been reported to have better predictive power on short-term horizons, while accountancy information is better on medium- to

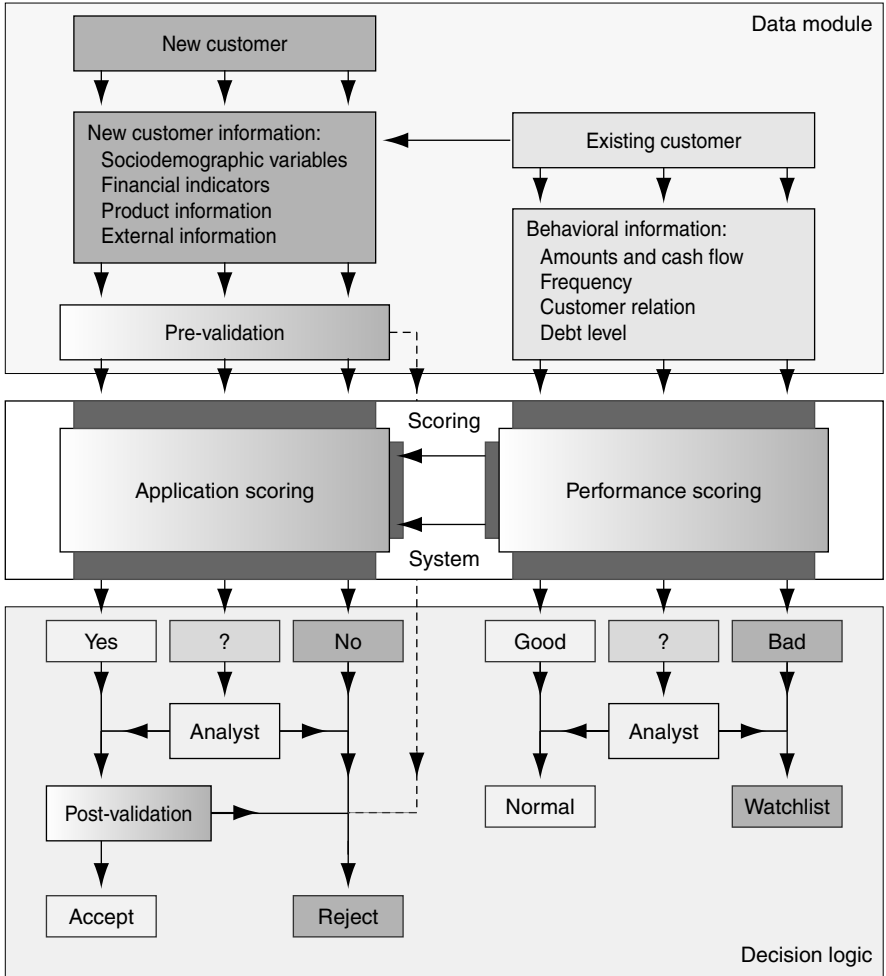

**Fig. 2.4** Example of application and behavioral scoring. For new customers, the application scorecard is used to support credit decisions. For existing customers, behavioral scores are used to monitor the risk of the existing portfolio. Information of a behavioral scorecard is used to improve application scores of existing customers and for other score types.

long-term prediction horizons [450]. For sovereigns, early warning systems also aim to capture problems other than debt crises [461].

Such systems can be considered as a specific case of performance scores with a short time horizon in the range 6–12 months. Most research and applications were applied to sovereigns and banking crises [71, 137, 147, 161, 293, 295, 365]. Recently, market information was also combined into special products like market implied ratings for firms [92, 100, 336, 408].



### 2.2.7 Attrition score

In a financial context, retention/attrition scoring is used to see which customers are likely to close their accounts, or significantly reduce their usage. Attrition scores are an important decision support system for customer relationship management [77, 127, 230, 292, 368, 406, 413, 420]. Classical variables for attrition scores are variables that are also used for behavioral scoring and the resulting behavioral score itself. These variables often include recency, frequency and monetary variables. Repurchase behavior is often predicted by these variables [32, 501, 502]. Customer interaction often also proves to be an important predictive variable.

Based on the attrition scores, financial institutions can start working out retention campaigns so as to pro-actively approach the customer in order to improve the relationship. Attrition scoring is also used by many non-financial companies (e.g., telco operators, supermarkets) in order to prevent customers from churning [32].

### 2.2.8 Collection score

Collection scoring is a decision support tool to manage bad debt. One rank orders customers already in payment arrears based on the probability of successfully collecting the outstanding debt. Knowing these scores will allow a financial institution to focus its collection efforts in the optimal way. For example, accounts with good collection scores can be treated using gentle reminders and phone calls, whereas accounts with bad collection prospects can be handled in a stricter way using, e.g., collection agencies. Of course, the cost of the collection process needs to be outweighed by the expected recovery taking into account the collection score. Sometimes collection scores are part of a global behavioral scoring system with a specific submodule that scores delinquent customers. When one starts proceeding with legal actions, the relation with the customer may change completely such that other collection scores not based upon past behavior become more applicable.

Collection scoring is still in a development phase. Many financial institutions are in this context experimenting with collection scoring in order to determine which bad accounts have good or bad collection prospects. Academic publications on collection scoring are limited, most research is business driven.

### 2.2.9 Profit score

Profit scoring takes a broader view and tries to score accounts or customers based on their probability of generating profit for the financial institution [292, 474, 476]. Account-level profit scoring calculates profit on an isolated account-by-account basis. It ignores the relationships and cross-selling effects that may exist between the different products a customer may have at a financial institution. For example, a customer may open a checking account in one bank and apply for a mortgage at a financial institution because that institution gave him the best mortgage rate [127]. Customer-level profit scoring calculates the total profit across all accounts a customer has at a financial institution. This provides a customer-centric view on the value of each customer for the institution and may be very useful for strategic decision making (e.g., offering new products) [187, 219, 406, 407, 474].

Developing customer-level profit scoring models is typically very complex because of several practical implementation issues. First, all the information of a customer needs to be centralized and his/her behavior on the various accounts collated together. One must then carefully decide how to define profit for each account. Direct and indirect benefits and costs need to be considered and also the timing of the cash flows and the corresponding discount factors need to be taken into account. Furthermore, it needs to be clearly stated how a customer is defined. A profit score for a customer can be calculated taking into account his private and/or business products, products owned by family members, . . . One also needs to determine the appropriate time horizon against which to calculate profit. Finally, since profit is dependent upon economic conditions, the impact of the latter needs to be carefully considered.

## 2.3 Score types

There exist a large variety of credit scores. In the remainder of this book, the focus is on different credit risk scores: application, performance and collection scores. Each of these scores has different specificities.

### 2.3.1 Score target

The score function target variable can be a probability of a discrete outcome (default/non-default) or a continuous variable. Most scores are default risk scores related with a delinquency, default or bankruptcy probability.

The probability indicates the risk that a loan will cause problems in the future. The exact definition of a problem loan will have an important impact on the risk probabilities assigned to a score. Recently, the Basel Committee on Banking Supervision has put forward a default definition that will serve for regulatory capital calculations [63].

Recent evolutions have led to the development of scores for loss and exposure risk. Profit scoring also has a continuous target variable. For risk management purposes, the LGD and CCF scores distinguish between high and low loss and exposure risk. Both variables express a relative risk measure with a typical target range between 0 and 100%. Loss and exposure risk are typically defined at a product level. In some applications, one scores the absolute loss numbers like the  $LGD \times EAD$  or the  $EAD$ . Sometimes, one combines the default risk with the loss risk to score the  $PD \times LGD$  or the absolute measure  $PD \times LGD \times EAD$ . Such scores combine several risk measures and simplify decision making. A disadvantage for the development is the mixed distribution with many values at zero.

The most common approach is to develop separate default, loss and exposure risk scores and to combine the information for decision making. Customers or products with both low default, loss and eventually exposure risk scores should be avoided. For the applicability in Basel II internal rating systems, LGD and CCF scores are mostly applied in a performance scoring context. LGD scores are particularly important because the LGD has an important impact on the resulting loss, but also on the capital consumption. For credit cards and revolving credits in general, CCF or EAD scores, possibly in combination with other risk measures are most relevant. Exposure risk is particularly relevant for off-balance sheet items such as credit cards, where the exposure is uncertain and driven by a customer's behavior. For these applications, customers can consume credit up to a certain limit and the exposure at time of default will typically be higher than the drawn amount at some time point before. Knowing how and why customers consume credit is very important in order to appropriately quantify the exposure risk. The scores are used to actively manage the limits of the most risky customers and products.

### **2.3.2 Counterpart vs. facility score**

The Basel II Capital Accord [63] defines the default risk as a risk of the counterpart. Loss and exposure risk are typically defined at the facility level

or for groups of facilities. For retail asset classes, default risk estimates can also be applied on a facility level.

It can be argued that when a customer runs into payment arrears on one credit facility, this is probably going to impact his default behavior on other facilities as well. This principle is known as contagion. It is mostly true for large counterparts with professional debt management. A default indicates severe financial distress that is very likely to impact all facilities. Loss risk is typically measured on a product level to take product specific features (debt seniority, collateral, . . .) additionally into account. In some cases, product or facility differentiation is not possible due to the low discriminative power of facility features or because of no product specific recovery cash flows in the work-out process. Exposure risk is very product specific with no risk for straight loans and high risk for overdraft facilities. Facility-level loss and exposure risk scores are aggregated at the counterpart level by calculating the exposure weighted loss or exposure risk measure.

In a retail environment, application scoring and behavioral scoring are mainly applied at the product or facility level. For retail customers, the principle of contagion is not mandatory. Each score provides a measure of default risk for the specific type of credit facility, by considering the characteristics or the behavior of the customer for that facility only. Customers having different credit products will thus have different application and/or behavioral scores. When facing financial troubles they are in many cases first shown by an overdraft on the checking account, which may be considered as a good indicator of a customer's overall financial health [476]. Retail customers often prefer to default first on a checking account than on a mortgage that would potentially cause housing problems. When the checking account default is due to temporary unemployment, it does not need to imply the default on the mortgage. Loss and exposure risk are typically measured on a facility level as for other asset classes.

Customer-level default risk scores provide a customer-centric view of his/her default behavior across all his/her entire product portfolio. These customer scores can then be usefully adopted to manage complex customer relationship, or, e.g., to set credit limits taking into account cross-product characteristics. There are two ways to develop customer-level credit scores. First, one could start by combining the various product-level application and behavioral scores available of a customer, using some weighting scheme, into one overall customer score. Although this may seem appealing at first sight, it is only a short-term solution, since it does not properly take into account the dependencies between the different products. A better alternative

would be to develop a new customer-level scorecard from scratch across all product facilities. In doing so, one would have to carefully think about which characteristics to include in the scorecard. New characteristics can be defined summarizing the properties of a customer's credit portfolio. Some examples are e.g., number of credits, maximum credit limit across facilities, maximum number of payment arrears on any facility, . . .

The relations between different products and customers become quite complex. A customer can have both private credit facilities and business-related credit facilities at a financial institution. Running into default on the business credit facilities does not necessarily imply that a customer is going to run into payment arrears on the private credit facilities. The default behavior for both these types of facilities may be totally different. Hence, it may be advantageous to develop separate customer scores for both types of facilities. Furthermore, when calculating customer scores measuring default behavior across a customer's portfolio, one needs to accurately define what constitutes this portfolio. A customer may have different roles with respect to a credit facility: primary owner, secondary owner, guarantor, . . . These roles should be clearly distinguished on beforehand and it should be decided how they are taken into account when defining a customer's credit portfolio.

### **2.3.3 Internal vs. external score**

Financial institutions can opt to develop the models themselves, or rely on external vendors providing credit scoring solutions. In the latter case, a sample of data is provided to the vendor who then develops a credit scoring model on this data. The vendor has a broad expertise in scorecard development and can also assist in the data collection and definition. Some known specialist vendors of scoring models are Austin Logistics, Experian, Fair Isaac, Magnify, Mercer, Scorex and SAS. Other consultancy companies and rating consultancy firms like Moody's, Standard&Poor's Risk Advisory and Fitch Algorithmics also provide related services. Vendors and credit bureaus are also in a unique situation to gather data across banks in different countries and set up data-pooling initiatives. Their long and broad experience allows them to sell also generic scorecards when a bank would have insufficient data history.

An often heard criticism is that the models returned are fairly black-box and hard to interpret correctly. The Basel Committee on Banking Supervision has communicated that it is the bank's responsibility to understand and monitor its internal scoring systems. The increased importance and widespread

use of credit scoring models nowadays has led financial institutions to develop their application scoring models more and more in-house.

When setting up an internal score system, it requires large efforts in data gathering, statistical analyses, documentation and ICT implementation. For a new product or market segment, one applies a generic internal scorecard from a similar segment, uses a vendor scorecard, buys data from a vendor or applies expert analysis to develop a scorecard or to score the counterparts. When sufficient internal data becomes available, an internal scorecard can be developed.

## 2.4 Credit bureaus

Financial institutions complement the application variables with variables bought externally from credit bureaus or credit reference agencies. These agencies collect information from various financial institutions and/or public authorities that report to them. By using information from the credit bureau, financial institutions have access to their client's financial status at other institutions.

The type of data gathered by the bureaus varies from country to country. Some bureaus only collect negative information (defaulted loans), whereas others also collect positive information (non-defaulted granted loans). The type of information collected is subject to privacy concerns and legislation. The bureau information can be directly incorporated into the scorecard or used as an additional policy rule on top of it. Example credit bureaus are: CKP (Belgium), BKR (the Netherlands), Baycorp Advantage (Australia & New Zealand), Equifax (United States, United Kingdom, Canada), Experian (United States, United Kingdom), . . . Dun & Bradstreet (D&B), headquartered in the US, is a leading provider of business information with main activities in risk management, sales and marketing, supply management and e-business. Its credit risk division acts as a scoring/rating company that provides credit risk information [421, 447]. Its best-known product is called DBNi and provides subscribers with credit-related information and scores on other companies [421, 447].

Credit bureaus have a number of advantages. First, by providing financial institutions with information on their customers at other institutions, the performance of their credit scoring models will definitely increase. A very important piece of information in this context is the number of inquiries registered at the credit bureau. Many inquiries made during a short period may be an indication that the customer is rate shopping at various financial

institutions, or a sign that the customer is opening multiple accounts due to financial problems. The latter will definitely be related to the default risk and hence may be an important characteristic to help credit scoring models better distinguish good payers from defaulters. Another advantage of credit bureaus is their ability to perform analyses at an aggregated level. An example is risk analysis at a zip-code level, where it is investigated whether some geographical regions have proportionally more defaulters than others.

Many credit bureaus nowadays also provide generic scorecards developed on a sample of applicants aggregated from different financial institutions. Well-known examples are the FICO (Fair Isaac Corporation) bureau scores provided by the US credit agencies Experian, Equifax and TransUnion. These bureau scores were developed by Fair Isaac and typically range between 300 to 850 with higher scores indicating less risk. The scores may vary from agency to agency depending on the credit information collected. These bureau scores can be very usefully adopted by financial institutions in a variety of different contexts. Applications are the introduction of new products for which no information is available at the institution yet, small institutions having insufficient resources to develop their own scorecards, or portfolios where only limited information and data are available. Finally, credit bureau scores can also be used for pro-active marketing purposes, e.g., to detect interesting prospects or potential churners based upon aggregated information at the bureau.

Information collected at the credit bureaus is in most countries accessible to the customers themselves. For example, in the US, customers are entitled to one free copy of their bureau information once every year. Using this information, customers may see how to augment their bureau scores, hereby improving their chances of getting future credit.

Credit bureaus are playing a very important role in today's credit environment. This role is going to be further reinforced by the introduction of the Basel II Capital Accord. Besides the advantages mentioned above, credit bureaus will also more and more act as a benchmarking partner that will allow financial institutions to validate and gauge the performance of their internal scorecards. However, since credit bureaus charge fees for providing their information, it needs to be investigated whether the benefits (e.g., added discriminatory power, benchmarking, validation, . . .) outweigh the costs. Rating agencies fulfill a similar role as credit bureaus on the asset classes of large counterparts (firms, banks and sovereigns). As will be discussed in the next chapter, rating agencies provide independent

and external risk assessments, software tools and additional consultancy services.

## 2.5 Overrides

Decisions made by a scorecard may be overruled by human judgment when extra information is present that has not been captured by the scorecard, or because of specific bank policies or strategies. A low-side override or upgrade override occurs when a customer is rejected by the scorecard, but accepted anyway because recent information indicated that the customer has improved (or is expected to improve) his financial status. The default status of the low-side override can then be subsequently tracked in order to determine whether one has made the right decision to accept the customer. A high-side override or downgrade override occurs when a customer is accepted by the scorecard, but rejected by the credit officer because new information showed, e.g., that this customer is expected to change his/her employment status in the near future. Since credit was rejected, the true default status of the customer will never be known, unless the customer gets credit elsewhere and his/her default status can be tracked via the credit bureau. Table 2.2 provides an example of an override report wherein the bold italic numbers indicate overrides.

It is important to note that an excessive number of overrides is a sign that one is no longer confident in the scorecard, and hence should consider rebuilding it. Financial regulators discourage financial institutions from doing *ad-hoc* overrides, but instead insist on having clearly, well-articulated override policies. An override is also known as overruling.

**Table 2.2** Override report on an application scorecard with cut-off level at 300.

Score range	Accepts	Rejects	Total
< 200	<b>2</b>	80	82
200–240	<b>5</b>	50	55
240–280	<b>10</b>	20	30
280–300	<b>12</b>	10	22
300–340	50	<b>10</b>	60
340–400	100	<b>8</b>	108
400–450	250	<b>5</b>	255
>450	300	<b>2</b>	302



## 2.6 Business objectives

Scoring techniques are applied for many different business objectives. The main objective of scoring is to improve customer-facility selection to reduce future losses. The success of scoring systems has made them a key decision or decision support tool in modern risk measurement and management.

Credit scores are used to calculate measures of expected or average loss of a credit portfolio. The expected loss on the portfolio determines the provision that the bank books (Table 1.1). In order to determine expected loss, the default risk of the credit portfolio needs to be adequately quantified and credit scores may prove to be very useful inputs for this. Closely related is the calculation of the regulatory and/or economic capital, which defines the buffer capital that protects the financial institutions and depositors against unexpected losses. In some applications, regulatory and economic capital calculations rely on credit scores as inputs for measuring the default risk of a portfolio. More details on regulatory capital calculations are given in Chapter 6.

Another use of credit scores is pricing. Risk-based pricing (sometimes also called risk-adjusted pricing) sets the price and/or characteristics of the credit product based upon the perceived risk as measured by the credit score. Customers having good credit scores and thus posing low risk can be rewarded by lower interest rates, whereas riskier customers having low scores get higher interest rates, and have to provide additional collateral/guarantees, or need to cap their credit amounts. A customer first applies for an initial offer and provides the financial institution with all his/her application details. A credit score is then calculated and used to further fine tune the offer in order to minimize the default risk. Financial institutions may then segment their customer population based on the credit scores and work out specific credit configurations for each segment, or they can also individually risk-price their customers.

Many financial institutions use securitization by pooling credit assets based on risk homogeneity and selling them off to third-party investors in order to reduce their credit risk. Credit scores can be very useful in slicing and dicing the credit portfolio into tranches with similar risk, and pricing the corresponding securities.

Credit scores, and more specifically bureau scores, are also useful to other non-financial companies in order to improve their decisions. An example are electricity and telecom operators that may want to use bureau scores in their

pricing or contracting policies. Also, employers could use bureau scores to get a better idea of the profile of job applicants, and landlords can use them to investigate the solvency of their future renters. Insurance companies could use credit scores to set insurance premiums or deciding for whom to accept the insurance policy. Note that most of these applications are still very controversial and subject to much debate.

Automated application scorecards allow fast credit approval decisions and reduce customer waiting time, which possibly increases the acceptance probability of the applicant if the score system accepts the loan. Automated scorecards are typically less expensive than human expert scores and ensure consistent decision making.

## 2.7 Limitations

Although credit scoring systems are being implemented and used by many banks nowadays, they do face a number of limitations. A first limitation concerns the data that is used to estimate credit scoring models. Since data is the major, and in most cases the only, input to building these models, its quality and predictive ability is key to their success. The quality of the data refers, e.g., to the number of missing values and outliers, and the recency and representativity of the data. Database biases are difficult to detect without specific domain knowledge, but have an important impact on the scorecard development and resulting risk measures. A key attention point in data quality for developing scores are the target variables: the list of defaults, including multiple defaults; the loss and exposure data. The disposal of high-quality data is a very important pre-requisite to build good credit scoring models. However, the data need not only be of high quality, but it should be predictive as well, in the sense that the captured characteristics are related to the customer defaulting or not. Before constructing a scorecard, one needs to thoroughly reflect why a customer defaults and which characteristics could potentially be related to this. Customers may default because of unknown reasons or information not available to the financial institution, thereby posing another limitation to the performance of credit scoring models.

The statistical techniques used in developing credit scoring models typically assume a data set of sufficient size containing enough defaults. This may not always be the case for specific types of portfolios where only limited data is available, or only a low number of defaults is observed. For these types of portfolios, one may have to rely on alternative risk assessment methods using, e.g., expert judgment based on the 5 Cs.

Financial institutions should also be aware that scorecards have only a limited lifetime. The populations on which they were estimated will typically vary throughout time because of changing economic conditions or new strategic actions (e.g., new customers segments targeted) undertaken by the bank. This is often referred to as population drift and will necessitate the financial institution to rebuild its scorecards if the default risk in the new population is totally different from the one present in the population that was used to build the old scorecard.

Many credit bureaus nowadays start disclosing how their bureau scores (e.g., FICO scores) are computed in order to encourage customers to improve their financial profile, and hence increase their success in getting credit. Since this gives customers the tools to polish up their scores and make them look “good” in future credit applications, this may trigger new types of default risk (and fraud), hereby invalidating the original scorecard and necessitating more frequent rebuilds.

Introducing credit scoring into an organization requires serious investments in information and communication technology (ICT, hardware and software), personnel training and support facilities. The total cost needs to be carefully considered on beforehand and compared against future benefits, which may be hard to quantify.

Finally, a last criticism concerns the fact that most credit scoring systems only model default risk, i.e. the risk that a customer runs into payment arrears on one of his/her financial obligations. Default risk is, however, only one type of credit risk. Besides default risk, credit risk also entails recovery risk and exposure risk. Recovery risk measures the expected recovery or loss for accounts already in arrears.

## 3. Credit ratings

---

### 3.1 Introduction

Credit risk basically entails default risk, recovery risk, exposure risk and maturity. In the past, bond investors and financial institutions often relied on external credit ratings measuring the relative creditworthiness of a particular issue or issuer. Ratings were first introduced in a firm context, e.g., bond markets. These ratings were provided by rating agencies like Moody's, Standard and Poor's (S&P), and Fitch that provide an independent risk assessment. Rating agencies fulfill the role of information intermediary between the bond investors and bond issuers. Nowadays, the agencies' activities are mainly financed by commission fees.

Ratings result from a thorough analysis of public and private information from all relevant sources. The rating process involves a quantitative analysis, which looks at the debt structure, financial statement, balance-sheet data and sector information. The qualitative analysis then looks at, a.o., management quality, competitive position, growth prospects, . . . Information is obtained from public sources and from the rated company itself during visits and meetings with the senior management. The credit rating is assigned by a rating committee of experts on different domains and is communicated with the senior management of the issuer that requested the rating. After the first rating assignment, the rating is re-evaluated on an ongoing basis by the agency until the rating is withdrawn.

The original purpose was to distinguish between investment grade and non-investment-grade debt securities. The first credit ratings aimed to provide an ordinal measure of the default or expected loss risk of the issued bond. Nowadays, credit ratings have been aligned to issuer default risk and issue loss or recovery risk. An example of a default risk rating scale is given in Table 3.1. The notion of expected loss ( $PD \times LGD$ ) risk is still available as well. Disintermediation, more efficient debt markets and the introduction of regulatory frameworks like Basel II, have further increased the importance of

**Table 3.1** Long term issuer default ratings by Moody's, Standard & Poor's and Fitch. Investment grade quality indicates good credit quality (Aaa–Baa3). Speculative grade ranges from Ba1 to C. The rating grades Aaa–C present an a-priori ranking of credit risk. The default state D is an *ex-post* observed state. The default state can be split up into the full default state (D) and the less severe selective or restrictive default state (RD, SD). Details on the rating grade definitions are available in section 3.4.

Moody's	S&P	Fitch	Credit quality
Aaa	AAA	AAA	Extremely strong
Aa1	AA+	AA+	Very strong
Aa2	AA	AA	
Aa3	AA–	AA–	
A1	A+	A+	Strong
A2	A	A	
A3	A–	A–	
Baa1	BBB+	BBB+	Adequate
Baa2	BBB	BBB	
Baa3	BBB–	BBB–	
Ba1	BB+	BB+	Speculative
Ba2	BB	BB	
Ba3	BB–	BB–	
B1	B+	B+	Highly speculative
B2	B	B	
B3	B–	B–	
Caa1	CCC+	CCC+	Vulnerable
Caa2	CCC	CCC	
Caa3	CCC–	CCC–	
Ca	CC	CC	Highly vulnerable
C	C	C	Extremely vulnerable
RD	SD	RD	Selective, restrictive default
D	D	D	Default

the credit rating industry. The Basel II Capital Accord explicitly recognizes the role of external credit assessment institutions (ECAI). The impact of the rating industry is now bigger than ever before since rating changes have a direct effect on capital market's equity prices, bond prices and risk management strategies [41, 146, 241, 296, 308]. Although external ratings cover a wide range of counterparts across broad geographical areas, there remain many counterparts in the banking books that do not yet have an external

rating. The Basel II Capital Accord has motivated financial institutions to develop internal rating systems for regulatory capital calculations.

This chapter is organized as follows. The relation between rating and scoring systems is discussed in section 3.2. Specific rating terminology is reviewed in section 3.3. Because of the increasing importance of ratings in time, there exist many rating types. A taxonomy of ratings is provided in section 3.4. The rating philosophy can range from through-the-cycle to point-in-time, as explained in section 3.6. An overview of external agencies that provide ratings is available in section 3.7. Internal rating systems in banks are reviewed in section 3.8. The application and use of ratings, but also limitations, are discussed in sections 3.9 and 3.10.

## 3.2 Rating and scoring systems

Both credit scores and credit ratings provide a credit risk assessment. When scores are gathered into homogeneous score segments or risk classes, the result of the score is a “rating”. The differences between scores and ratings become blurred. The score terminology is particularly used in retail environments where large customer databases are scored automatically by mostly statistical scoring systems. Ratings are assigned to bond issues and take into account objective as well as subjective elements. The subjective elements aim to capture outlooks and future evolutions. Ratings result from a manual process that may take days to weeks to complete.

Score systems and bureau scores are mainly used for internal purposes, whereas external credit ratings are made public by the rating agencies for investors. The rated companies publish their ratings to raise capital, because the rating is an important element of their funding strategy. Rated companies are sufficiently big, because they need to dispose of a sufficiently developed financial management to raise capital from the capital markets, a.o., from bond markets. Therefore, issue ratings typically concern publicly traded debt. Individuals, however, do not publish their scores<sup>11</sup>. Also for bank loans, there is often no interest in requesting the rating. Whereas agency ratings are generally made public, internal credit ratings and scores are typically not.

The difference between internal scores and internal ratings has faded away. To ensure rating consistency, internal ratings are based upon mathematical

<sup>11</sup> This behavior may change in internet market places where individuals borrow or lend money to other individuals.

models that provide a score or rating range based upon which the final internal rating is decided by a committee of experts. The override of the mathematical rating is subject to written internal rules and policies to ensure objectivity of the internal rating. Apart from the larger impact of subjective elements, internal ratings do not differ systematically from internal scores. Because internal ratings are used on asset classes similar to those rated externally, the scale of internal ratings is often very similar to those of external ratings reported in Table 3.1.

Ratings are typically performance ratings that express an ordinal risk measure. The ratings published by the agencies do not reflect a guaranteed default risk. Investors decide what price they accept given the rating when making the investment. Scores exist for various purposes, application and behavioral scoring being the most important ones for retail customers. For retail customers, individual ratings are not required for Basel II capital calculations, it is allowed to measure the risk on homogeneous pools of customers.

Internal scores and ratings are used for internal risk management and regulatory capital calculations. External ratings are used by banks for the same purposes and for benchmarking their internal ratings with external ratings. External ratings are also consulted by investors for various purposes in finance: investment decisions, pricing, portfolio management, . . . External ratings are mostly available for large companies, banks and sovereigns. Internal scores and ratings nowadays cover almost the whole banking book of advanced banks.

### 3.3 Rating terminology

The rating industry uses specific terminology. An overview of the most important terms is given below.

#### 3.3.1 Rating lifetime

A rating is said to be new when it is assigned for the first time to an issuer or issue. Ratings are reviewed on a regular basis by the agencies. A rating is affirmed if the review does not indicate changes. One speaks about a confirmation when the review was triggered by an external request or change in terms. A rating is downgraded/upgraded when the rating has been lowered/raised in the scale. During the lifetime of the issue or issuer, the rating can be withdrawn. This means that the rating is removed for any reason (mergers and acquisitions, not sufficient information, rating contract

stopped, . . .) and is no longer maintained by the agency. The rating is also stopped when the issue is paid in full (PIF), when the issue reaches maturity or when the issue is called early or refinanced. Statistics of rating agencies do not indicate at this moment that rating withdrawals indicate higher risk.

### 3.3.2 Rating watch and outlook

Ratings also have a rating outlook that indicates the medium-term potential evolution of the rating in the future. A positive/negative outlook indicates that the rating may be raised/lowered. A rating with a stable outlook is not likely to change. A developing rating outlook means the opposite of a stable rating: the rating may be lowered or raised. Credit watchlists are used to determine shorter-terms evolution. A ratings is put on the watchlist when an event or deviation from the expected trend occurs and there is a reasonable probability for a rating change.

### 3.3.3 Rating qualifiers

Rating qualifiers give additional information on the specific meaning of the rating. The most important qualifiers are

“pi”: A “pi” rating is based only on published financial information and other public information. It is not based upon site visits and meetings with the issuer’s management. The “pi” ratings are based upon less information than ratings without the “pi” add-on. Fitch also uses the suffix “s” for this purpose.

“q:” The qualifier reflects that the rating is the result of a statistical rating model that is fed with ratios and variables derived from the financial statements.

“p”: The rating reflects the likelihood of repayment of the principal portion of the obligation only. It is used when the assessment for principal is different from the other factors.

“i”: The rating reflects the likelihood of repayment of the interest. It is used in conjunction with the “p” qualifier. The rating “AAp NRi” indicates that the principal portion receives the rating AA, but the interest portion is not rated.

“pr”: Provisional ratings reflect the credit quality assuming that the rated project is successfully completed. The provisional rating does not cover the project risk.



## 120 Credit ratings

“t”: It reflects termination structures that are designed to honor their contracts at maturity or before.

“\*”: The rating opinion is a shadow or conditional rating. Shadow ratings are typically not intended for publication. They are typically used as input opinions for other work. The shadow rating may be subject to assumptions and information other than regular ratings.

Preliminary or expected ratings are assigned to issues that have not yet completed fully the documentation and not yet have received a completed legal opinion.

Some of these rating qualifiers are specific to the rating agency and have evolved. It is important to consult the agency’s rating definition for a correct interpretation and understanding when making important decisions based upon the rating.

### 3.3.4 Solicited versus unsolicited ratings

Solicited ratings are ratings that are initiated and paid for by the issuer. However, some issuers do not want to be rated because they seldom raise debt or equity in international financial markets, or because they are afraid of getting an unfavorable rating that may limit their future access to funding. Based on public information available on them, they may get rated anyway, resulting in unsolicited ratings. Given the limited information on which the latter are based, empirical evidence has shown that unsolicited ratings may be biased downwards when compared to solicited ratings [397]. When assigning an unsolicited rating, the agency has typically more restricted access to information.

### 3.3.5 Split ratings

The spectacular growth in the number of credit rating agencies causes many debtors or debt instruments to be rated multiple times [67]. A split rating arises when different agencies assign different ratings to the same debtor or instrument. The impact of these differences is now bigger than ever. Since ratings provide the key input for the regulatory capital calculation in a Basel II environment, split ratings will lead to different levels of safety capital. Banks can then cherry-pick the rating agencies with a view to minimizing their safety capital, which is of course an undesirable practice. Furthermore, investors will react differently based on whether a

debt instrument is characterized by multiple equivalent ratings or when split ratings are present.

Split ratings may also directly impact regulations, since regulators may put restrictions on the number of speculative investments and a debt instrument may be considered speculative by one agency and non-speculative by another. Reasons for split ratings are, e.g., different rating methodologies, access to different information, use of different rating scales, and sample selection bias. Many studies investigate the difference between rating agencies (see, e.g., [67, 103, 285, 286, 444]). The equivalence between Moody's and S&P ratings has been identified by many researchers [103, 285]. The existence of split ratings necessitates the refinement of existing regulations. That is why, in a Basel II context, banks are prohibited from cherry-picking their rating agencies, but instead should use a consistent rating policy based on a well-considered choice of rating agency [58].

In the case of split ratings, regulations typically prescribe the use of the worst rating in the case of two and the median rating when there are more ratings available. A general rule could be considered as taking the conservatively rounded median rating.

### 3.4 A taxonomy of credit ratings

The taxonomy will give an extensive overview of the different aspects of ratings (Table 3.2). Although the emphasis is on external ratings [109], most aspects are applicable to internal ratings as well.

#### 3.4.1 Short-, Medium- and long-term ratings

Ratings are defined for different time horizons. Short-term credit ratings measure credit risk over a short time span (e.g., 1 year) and reflect a debtor's ability to fulfill his short-term financial obligations. Medium- and long-term ratings typically consider longer time periods. Rating agencies may adopt different rating scales for both types of rating horizons [452].

Moody's reports the gradation of long-term credit risk by means of 9 rating symbols with increasing credit risk: Aaa, Aa, A, Baa, Ba, B, Caa, Ca and C. Numerical modifiers 1, 2 and 3 are applied to each broad rating class ranging from Aa to Caa and indicate a high, medium and low ranking in the broad rating class. These rating modifiers provide a more granular risk assessment. Standard and Poor's (S&P) and Fitch use the broad rating symbols AAA, AA, A, BBB, BB, B, CCC, CC and C. Rating modifiers + and - are introduced

**Table 3.2** Ratings cover many different aspects: prediction horizon, prediction method, object of rating, risk type, local and foreign currencies, national orderings. There exist specific types of ratings, like stand-alone and support ratings, country and country ceiling ratings. An overview is discussed in section 3.4.

Rating Aspect	Section
Timing: short, medium, long term	3.4.1
Issuer and issue	3.4.2
Quantitative and qualitative ratings	3.4.3
Risk type	3.4.4
Probability of default	3.4.4.1
Loss given default	3.4.4.2
Exposure risk	3.4.4.3
Expected loss	3.4.4.4
Local and foreign currency	3.4.5
National scale	3.4.6
Stand-alone ratings	3.4.7
Claims payability and deposit ratings	3.4.8
Municipal ratings	3.4.9
Support ratings	3.4.10
Country and country ceiling ratings	3.4.11

to indicate the relative ranking in a broad rating class. The resulting rating scale is reported in Table 3.1. Although the exact rating definitions differ from one agency to another, credit rating levels are considered in industry practice as being more or less comparable. The long-term rating symbols have the following meaning:

**AAA, Aaa:** Extremely strong credit quality with extremely low expected credit risk. It is highly unlikely that the ability to pay the financial commitments will be adversely affected by foreseeable events. It is the highest credit rating.

**AA, Aa:** Very strong credit quality that reflects very low credit risk. There is a strong capacity to honor the financial commitments that is unlikely to be affected by foreseeable events. The difference from the top rating is limited.

**A:** Strong credit quality with low credit risk. The payment ability is judged strong, but is more vulnerable to changes in the economy.

**BBB, Baa:** Adequate credit quality reflects currently a moderate credit risk. Whereas the payment ability for the financial commitments is currently judged as adequate, adverse changes and economic conditions may further

weaken and impair the payment ability. It is the lowest investment grade rating.

- BB, Ba:** Speculative credit quality indicates that credit risk will possibly develop, especially in adverse circumstances. Financial commitments are still likely to be met, but there are speculative elements and major ongoing uncertainties. It is the highest speculative grade rating.
- B:** Highly speculative credit quality reflects high credit risk. A significant credit risk is present, but a limited safety margin remains. Adverse business, financial or economic circumstances will likely impair the repayment capacity. Issues with this rating indicate very high recovery potential.
- CCC, Caa:** Vulnerable credit quality and very high credit risk with credit events being a real possibility. Favorable business and economic conditions are likely to reduce the risk. Adverse economic circumstances will make credit events imminent. Issues with this rating have good recovery expectations.
- CC, Ca:** Highly vulnerable credit quality with default becoming highly probable. Issues with this rating have medium recovery ratings.
- C:** Extremely vulnerable credit quality with threat of imminent credit events. Issues with these ratings have a poor recovery prospective.

The meaning of the rating symbols of the rating agencies is available from their websites.<sup>12</sup> Medium-term ratings are expressed on the same rating scale.

Short-term ratings indicate the repayment ability on short-term financial obligations ( $\pm 1$  year). Liquidity quality is of higher importance for short-term ratings. Moody's makes the distinction between prime (P) and not prime (NP) short-term repayment ability. The prime grade P has three levels P-1, P-2 and P-3 reflecting superior, strong and acceptable repayment ability for short-term debt. The NP rating reflects more important risk categories. S&P expresses the short-term credit risk by means of A, B and C ratings that reflect good, vulnerable and high repayment risk. The A and B levels have 3 levels: A-1 (strong), A-2 (satisfactory), A-3 (adequate), B-1 (low vulnerability), B-2 (medium vulnerability) and B-3 (high vulnerability). Rating C reflects the fact that default is a real possibility. Fitch uses the ratings F, B and C. The rating F reflects very good capacity to repay timely the short-term financial obligations. It has 3 levels: F-1 (high), F-2 (good), F-3 (fair). The ratings B and C denote speculative quality and high default risk, respectively.

The credit ratings reflect an a-priori credit risk assessment. The default state D is not a risk assessment, but an observed state. It is not forward

<sup>12</sup> Fitch: [www.fitchratings.com](http://www.fitchratings.com); S&P: [www.ratingsdirect.com](http://www.ratingsdirect.com); Moody's: [www.moody's.com](http://www.moody's.com).

looking. Also, the default definition can be expressed in more detail. Refined default definitions include: selective default (SD), restrictive default (RD) for defaults on some, but not all material commitments of an obligor. Such ratings are assigned when the issuer defaults on some issues, but not on all material issues. Obligors put under regulatory supervision because of its financial situation receive a “R” rating. The label “NR” indicates that there is no rating, because it was not requested, there is not sufficient information or it is not rated because of the agency’s policy.

Rating agencies aim to provide uniform rating meanings across different geographical sectors and industry sectors, as a rating should have a similar meaning independent of the sector or region. The efforts of the agencies and statistical evidence allow us to conclude that this is the case for most sectors and regions, although recessions may hit one sector more than another. Municipal ratings are known to have lower risk than similarly rated firm counterparts.

### **3.4.2 Issue and issuer ratings**

Another distinction relates to the underlying entity that is being rated. An issue-specific credit rating is defined by considering the characteristics of the issuer together with those of the issue. The issuer credit rating is an overall judgment of the obligor’s ability to meet his financial commitments [231, 452]. Issuer credit ratings reflect the issuer’s fundamental credit risk, hereby making abstraction of security-specific differences related, e.g., to seniority, collateral, and/or guarantees.

Note that some rating agencies (e.g., Moody’s) use senior unsecured credit ratings as a proxy for deriving an issuer rating [231]. When no such rating is present, a mapping methodology can be used to infer the issuer rating from ratings on other (e.g., subordinated, junior) obligations as illustrated in Table 3.7 [99, 231] in the next section. Examples of issuer credit ratings are firm credit ratings, sovereign credit ratings, and stand-alone bank ratings [452]. Examples of issue ratings are recovery ratings and expected loss ratings. These ratings can be obtained by notching up and down the issuer rating.

### **3.4.3 Quantitative and qualitative ratings**

Ratings can be assigned in many ways. Quantitative ratings are based on quantitative information only. In many cases, quantitative information like financial statements are fed into a rating model that (semi-) automatically

produces the rating. Qualitative ratings are assigned by a process of human expert analysis. The rating is based upon financial information, of which a qualitative expert appreciation is given by an expert or a rating committee.

Examples of pure quantitative ratings include the “q” ratings discussed above, equity and market implied ratings [92, 100, 336, 408]. The latter ratings result from a statistical analysis and benchmarking of the market price (equity price, bond spread, CDS price). In the case of bonds, one compares the bond spread of an issue to a large number of rated bonds. The mathematics of these pure quantitative ratings are explained in subsequent chapters.

Qualitative ratings are typically assigned to sectors with very low data availability by financial experts only. Nowadays, many ratings are based upon quantitative ratings and complemented with qualitative expert knowledge.

### **3.4.4 Default, recovery, exposure and expected loss ratings**

Credit ratings can be categorized according to various criteria. A first distinction relates to the type of risk that is being measured. Four types of ratings can be distinguished according to this criterion: default ratings, recovery ratings, credit conversion factor (CCF) ratings and expected loss ratings. Default ratings provide an ordinal scale of default risk. Recovery ratings provide a ranking based on recovery perspectives in the case of default, whereas CCF ratings provide an ordinal opinion on the exposure prospects for, e.g., off-balance sheet items. Both default and recovery ratings can be combined into an expected loss rating, giving a joint view on both the default and recovery risk of an underlying entity. Much of the attention thus far, both in the industrial and academic world, has largely focused on default ratings. However, partly because of regulations such as Basel II, recovery ratings and expected loss ratings are gaining in importance.

Default risk ratings are discussed in section 3.4.4.1. Recovery ratings are reviewed in section 3.4.4.2. Exposure risk ratings are relatively new and are mentioned for the sake of completeness in section 3.4.4.3. Expected loss ratings combine default and recovery risk, as explained in section 3.4.4.4.

#### **3.4.4.1 Default risk ratings**

Default ratings are nowadays the most commonly used type of credit ratings and measure the relative default risk of an issuer in terms of the probability of default (PD). Different definitions of default may be adopted by the rating agencies. The difference of the agencies’ default definitions from the Basel II

default definition are discussed in Chapter 4. The agencies' definitions are usually based on the occurrence of a delayed payment of interest and/or principal on any financial obligation. The definitions may differ on how they treat missed payments that were made during a grace period or missed payments because of commercial disputes [234, 375, 500]. An overview of the default definitions is given in the next chapter.

The long term rating scale of Table 3.1 reports the definitions adopted by Moody's, S&P's and Fitch. This rating scale reflects the default risk of an issuer. Issue ratings have the same rating scale, but it is important to note that differences between issue and issuer ratings may exist. Moody's long-term ratings reflect both default risk and recovery risk. The senior unsecured debt issue ratings are typically the reference rating for an issuer and are less influenced by the LGD aspect of the issue. In practice, the senior unsecured rating is a good proxy to the issuer rating and enables default risk to be compared across different issuers.

The ratings have been divided into investment grade (inv. gr.) and speculative grade (spec. gr.). Speculative grades are also called high-yield grades, non-investment grades. Such issues are also called junk bonds. Regulatory institutions use this distinction to regulate the investments in speculative securities made by banks, insurance companies and other financial institutions. The increased default risk of lower ratings is reflected in price differences and higher interest rates for the riskier bond issuers [286].

PD ratings are based upon statistical models that learned from past default behavior or on structural models based upon economic and financial theory and simulation as explained in the next chapter. As explained above, the PD ratings are often complemented with expert judgment. It is important to note that default ratings only provide an ordinal, relative measure of default risk. Practitioners typically complement the ordinal feature with a cardinal measure of default risk, which is called the default rate. One keeps databases with the assigned ratings and counts how many observations did default after 1, 2 or more years. Past default experience is used to calibrate<sup>13</sup> the default risk to the different ratings. As an example, an overview of historical 1-year default rates reported by the agencies is reported in Fig. 3.2a based upon the rating reports [233, 375, 500]. Observe that the historical default rates typically exhibit an exponential relation with the ratings expressed

<sup>13</sup> The calibration is an important element of the risk modelling as explained in the next chapter. An overview of calibration techniques is available in Book II.

on a numerical scale ( $AAA = 1, \dots, CCC = 17$ ). The log-linear relation visualized in Fig. 3.2b is often used to idealize the default rates [82]. In addition to one-year default rates, default rate statistics are also available for longer time horizons, e.g., 5 years as reported in Table 3.4. Such default rates are important for evaluating the pricing of longer-term investments. Average cumulative default rates for broad rating classes are visualized in Fig. 3.1b. Cumulative default rates increase by definition the longer the period after the rating or cohort date. Low-quality issuers tend to either default or survive with an improved rating. As a result, their cumulative default rates increase at a lower pace after a few years. This effect is known as seasoning. Better ratings, on the other hand, tend to lose quality and cumulative default rates tend to increase at a faster rate with a convex behavior. In Fig. 3.1b the default rates of Baa increase almost linearly, better ratings increase faster, while lower ratings clearly exhibit a convex cumulative default rate.

It is important to stress, however, that past default experience does not guarantee future performance. The default rates may fluctuate significantly with the business cycle, as can be seen from Fig. 3.1a. Ratings are relative predictions of credit risk, not absolute, whereas default rates are absolute, and may exhibit drift over time [101].

Rating assessments may evolve across time. It is said that the rating of a company migrates, e.g., from A- to BBB+. Such a rating migration is called a rating downgrade. An upward rating migration or transition is, e.g., a 2-notch upgrade from BBB+ to A. An upgrade reflects the fact that the default risk is reduced, a downgrade implies an increased default risk. The market prices of the existing fixed-rate bonds of a downgraded issuer will decrease because the fixed interest rate is not adjusted for the additional credit risk. A downgrade means a “mark-to-market” loss when the investor would like to sell the loan or bond on the secondary market. In the case the bond is held to maturity and the issuer does not further downgrade to default, no loss is realized. As shown in Table 3.3, migration or transition matrices are typically diagonally dominant, meaning that many issuers maintain their rating and only a minority migrate towards other ratings. Transition matrices can be computed for one-year or multiple years. When one can assume that the process is Markovian,<sup>14</sup> simple matrix multiplication can be used to calculate multiperiod transition matrices. In the case a default issuer will not

<sup>14</sup> In a Markovian process, future evolutions or migrations depend only on the current state, not on, e.g., past states. See, e.g., [279] for more details.



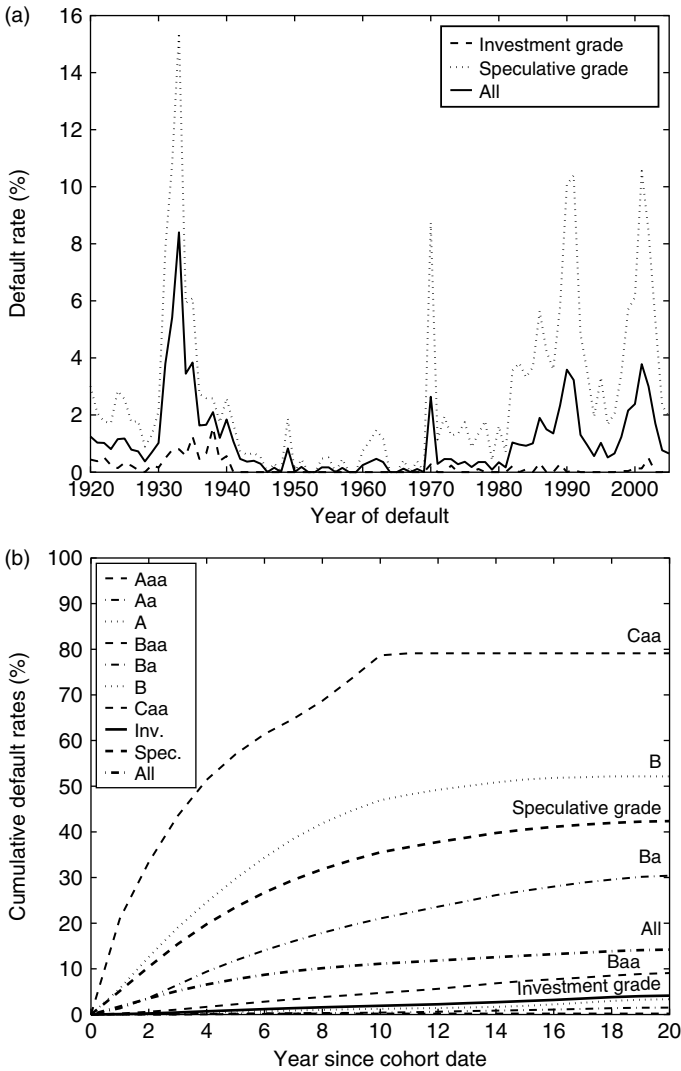

**Fig. 3.1** Time aspects of PD ratings. Panel (a) depicts the evolution of Moody's 1-year default rates for investment grade, speculative and all ratings for the period 1920–2005 [233]. The default rates fluctuate, a.o., with the economic cycle. Speculative grade default rates exhibit large peaks in recession periods. During expansion periods, investment grade 1-year default rates are close to zero. Panel (b) reports the average cumulative yearly default rates by whole letter rating for the period 1983–2005 [233]. For good ratings, cumulative default rates tend to increase fast as their rating quality deteriorates. For bad ratings, cumulative default rates increase slower at longer time horizons. If the issuer does not default, the rating improves and default rates reduce. The default rates of the good ratings are very low compared to the other ratings. The default rates for investment grade, speculative grade and all counterparts are shown by the bold lines.

(a) LTRating	Moody's	Fitch	S&P	Average	Idealized
AAA	0.00%	0.00%	0.00%	0.00%	0.00%
AA+	0.00%	0.00%	0.00%	0.00%	0.00%
AA	0.00%	0.00%	0.00%	0.00%	0.01%
AA-	0.02%	0.00%	0.02%	0.01%	0.01%
A+	0.00%	0.00%	0.05%	0.02%	0.02%
A	0.03%	0.00%	0.04%	0.02%	0.04%
A-	0.04%	0.12%	0.04%	0.07%	0.06%
BBB+	0.17%	0.29%	0.21%	0.22%	0.11%
BBB	0.16%	0.13%	0.30%	0.20%	0.20%
BBB-	0.34%	0.56%	0.39%	0.43%	0.36%
BB+	0.75%	0.91%	0.65%	0.77%	0.63%
BB	0.78%	1.80%	0.96%	1.18%	1.13%
BB-	2.07%	1.94%	1.80%	1.94%	2.00%
B+	3.22%	1.82%	3.21%	2.75%	3.55%
B	5.46%	1.78%	8.87%	5.37%	6.31%
B-	10.46%	1.69%	12.99%	8.38%	11.21%
CCC	20.98%	26.07%	31.08%	26.04%	19.92%
Inv.Gr.	0.08%	0.11%	0.11%		
Spec.Gr.	5.15%	3.27%	4.65%		
All	1.74%	0.65%	1.61%		

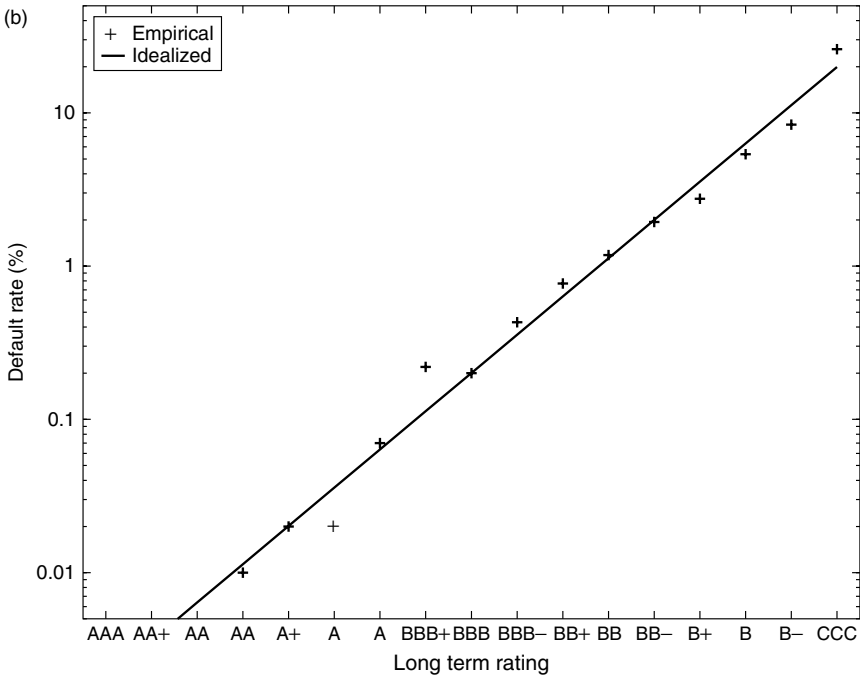

**Fig. 3.2** Empirical 1-year default rates and idealized default rates for firm bond issuers. The top panel reports the yearly default rate statistics reported of Moody’s (1983–2005), Fitch (1990–2005) and S&P (1981–2005) [233, 375, 500]. The default rates are reported for all ratings and for investment grade, speculative grade and all counterparts. The average default rates of the three agencies as well as the exponentially idealized default rates are reported in the last two columns. The latter are visualized on the bottom panel.

## 130 Credit ratings

**Table 3.3** Example migration matrix for JPMorgan Chase [24]. The 1-year migrations are reported on broad rating classes, AAA is combined with AA in this matrix. The default state D is an absorbing state.

From/To	AA	A	BBB	BB	B	CCC	CC	D
AA	<u>91.30%</u>	5.62%	0.84%	1.03%	1.11%	0.03%	0.00%	0.08%
A	5.98%	<u>85.91%</u>	5.71%	1.67%	0.53%	0.09%	0.03%	0.09%
BBB	0.66%	7.02%	<u>84.31%</u>	6.96%	0.78%	0.11%	0.05%	0.10%
BB	0.08%	0.58%	3.99%	<u>89.28%</u>	4.81%	0.43%	0.26%	0.57%
B	0.12%	0.08%	0.26%	<u>10.95%</u>	<u>84.07%</u>	1.61%	1.06%	1.86%
CCC	0.00%	0.18%	0.09%	1.99%	<u>15.10%</u>	<u>63.47%</u>	9.13%	10.04%
CC	0.10%	0.10%	0.10%	1.40%	4.60%	<u>1.40%</u>	<u>74.57%</u>	17.72%
D	0.00%	0.00%	0.00%	0.00%	0.00%	0.00%	0.00%	<u>100.00%</u>

**Table 3.4** Average cumulative default and expected loss rates calculated by Moody's for firm bond issuers observed during 1920–2005 [233].

LTRating	Default rate		Expected loss	
	1-year	5-years	1-year	5-years
Aaa	0.00%	0.09%	0.00%	0.00%
Aa	0.01%	0.20%	0.00%	0.08%
A	0.02%	0.56%	0.01%	0.23%
Baa	0.21%	2.25%	0.11%	1.24%
Ba	1.31%	11.85%	0.77%	7.04%
B	5.69%	29.73%	3.61%	18.61%
Caa	20.98%	57.01%	14.43%	37.70%
Inv.Gr.	0.08%	0.93%	0.04%	0.77%
Spec.Gr.	5.15%	23.49%	3.25%	26.97%
All	1.74%	7.73%	1.08%	6.97%

emerge from default or would reappear as a new, reborn issuer, the default state D is an absorbing state. Migration analysis is important for the analysis of portfolio risk when the portfolio value is mark to market [82, 133], as will be discussed in Chapter 5. Although the assumption of constant Markovian migration probabilities, where the migration probability only depends on the current state, is often made, there are some observations that indicate aberrations:

1. Migrations also indicate changes of the credit quality that are not fully consistent with the Markovian assumption. Downgrades tend to be more easily followed by further downgrades and even default. The negative

- instability reflected by negative and downgrade outlooks is also reflected by higher than average default rates of stable, equally rated issuers [232].
2. A duration dependence effect has been reported in [203]. The longer an issuer keeps the same rating, the lower becomes the migration probability and the more stable is the rating.
  3. Migration probabilities are time varying and tend to be correlated with the business cycle, especially for speculative grade ratings [377].

The first two observations reduce the quality of the idea that ratings represent uniform and homogeneous pools with the same risk. The third observation is particularly important for mark-to-market portfolios. During economic downturns, there may be many more downgrades resulting in higher market value losses than expected in average years. The impact of all three aberrations on risk measures like mark-to-market portfolios needs to be analyzed, especially when working on longer-term horizons.

In the Basel II context, default ratings are assigned at the issuer level. In the past, ratings were defined mainly at an issue level to reflect the specific risk of a bond or other financial product. Such ratings were also represented on the same scale as issuer default ratings and may also have (sometimes partially) expected loss notions. It is important to be aware of the different credit risks that are expressed on the same scale when making decisions based upon a rating that may have different interpretations depending on the circumstances.

#### 3.4.4.2 Recovery ratings

Recovery risk is the uncertainty of the recovery prospects when default has occurred [113, 354, 418, 452]. The recovery rating indicates the expected recovery rate. The interest in recovery risk has been reinforced by the growing popularity of securitization, and the introduction of the Basel II framework (see Chapter 6) that disentangles credit risk into probability of default (PD), loss given default (LGD), exposure at default (EAD) and effective maturity (M). The LGD quantifies the economic loss as a percentage of exposure in the case of default. It is usually expressed as a percentage of principal and accrued interest at the resolution of default [418]. The LGD is related to the recovery rate as follows:

$$\text{Loss given default} = 1 - \text{Recovery rate.}$$

Rating agencies and financial institutions are building rating systems providing recovery ratings and corresponding recovery rates or LGDs. Recovery

ratings are based upon statistical models that learned from past behavior or on structural models based upon economic and financial theory and simulation, as explained in the next chapter. Recovery or LGD ratings provide an evaluation of the recovery prospects in the case of default and reflect an ordinal segmentation of the recovery risk. Good recovery risk indicates almost no loss in the case of default, bad recovery ratings indicate almost a total loss. When past loss information exists, the recovery ratings can be calibrated to an expected value. The expected value is possibly adjusted for economic downturn periods. In practice, observed recoveries on individual issues exhibit an important variability around the recovery rating average, up to 20 and even 30% [11].

The recovery rating scales used by the agencies are reported in Table 3.5 and indicate an ordinal measure of the recovery/loss risk. Recovery ratings were introduced only very recently. In contrast to the default rating, the limited availability of recovery data makes the actual calibration of the recovery rates to the recovery ratings, based upon historical data, not yet possible. The agencies have provided ranges for the recovery rates. Note that for Moody's and Fitch, the recovery ratings are identical and expressed in terms of outstanding principal and accrued interest, whereas for S&P only outstanding principal is considered.

Fitch defines outstanding (RR1), superior (RR2), good (RR3), average (RR4), below average (RR5) and poor (RR6) recovery prospects given default. Distressed recovery ratings DR1, . . . , DR6 are assigned to currently distressed or defaulted structured finance securities. S&P defines 1+ and 1 as the highest and high probability of full recovery of the principal. Ratings 2, 3, 4 and 5 indicate substantial, meaningful, marginal and negligible recovery of principal. It is likely that a scale with 7 levels will be applied in the

**Table 3.5** Recovery and LGD rating scales adopted by Moody's, S&P's, and Fitch [354, 418, 452]. Precise definitions and possible updates of the scales can be obtained from the rating agencies.

	Moody's (LGD)	S&P (recovery)	Fitch (recovery)
LGD6	90–100%	1+ 100%	RR1 91–100%
LGD5	70–90%	1 100%	RR2 71–90%
LGD4	50–70%	2 80–100%	RR3 51–70%
LGD3	30–50%	3 50–80%	RR4 31–50%
LGD2	10–30%	4 25–50%	RR5 11–30%
LGD1	0–10%	5 0–25%	RR6 0–10%

future [301]. Precise information on the recovery scales and their meaning is available from the external rating agencies. Note that recovery ratings may also migrate from one year to another, but external data for migration analysis remains limited.

Recovery ratings are primarily assigned to issues. Different issues with different (relative) seniorities of the same issuer may have different recovery ratings. Issuer recovery ratings can be obtained as a weighted average of the financial obligations of the issuer, whereby the weights are based on the outstanding exposure of the obligations [418]. The Basel II Capital Accord requires that recovery or loss ratings are assigned on an issue basis. When recovery ratings are based upon market prices of defaulted bonds, *ex-post* issue recovery rates are calculated in a straightforward way. In workout processes, it can be less straightforward to allocate recovery cash flows to the different issues and *ex-post* calculations per issue can be more difficult. It may not be clear whether a post-default recovery payment serves to pay the mortgage, the credit facility or the unsecured loan. These practical elements are explained in detail in the next chapter.

Recovery ratings are especially important for the lower default ratings, since for these obligors default is imminent and any differences in recovery values may be important for quantifying the expected loss [354]. Factors that may influence the recovery ratings and rates are, a.o., exposure, industry sector, economic cycle, collateral, seniority relative to other obligors, issuer characteristics, default rating, country and legislation effects, . . . [193, 221, 354, 418, 452].

### 3.4.4.3 Exposure ratings

Future exposures may fluctuate for some types of financial products. For bonds, the exposure at default is not so variable, whereas revolving credits, credit cards, credit lines and credit facilities are typically characterized by uncertain exposure amounts, thereby introducing exposure risk. The potential future exposure will fluctuate significantly for derivative products like options, warrants, etc. For cases where the off-balance exposure is fixed, the exposure risk is reflected by the credit conversion factor. The exposure at default (EAD) is observed at the moment of default (or later as explained in the next chapter) and varies typically between the drawn amount at the prediction date and a fraction of the undrawn available amount, which of course depends on the credit limit provided. The latter fraction is often referred to as a credit conversion factor (CCF). The following relationship

then holds:

$$\text{EAD} = \text{drawn amount}_t + \text{CCF} \times (\text{credit limit}_t - \text{drawn amount}_t).$$

The prediction is typically made at time  $t$  in the year before default. The CCF then varies between 0 and 1 depending on how much of the undrawn amount (credit limit – drawn amount) is consumed. Values below 0 can occur if the bank was able to reduce the exposure before the default event. CCF values above 1 are observed when additional credit lines are allowed before the default event.

Banks will need to predict future exposure for these products, i.e. estimate the expected part of the not yet drawn commitment. The estimation problem is similar to the recovery rate estimation, both are continuous variables. Exposure ratings are in that sense similar to recovery ratings. Banks will define segments of homogeneous exposure risks, where each segment defines an exposure rating to which an average credit conversion factor is calibrated. Such ratings are mainly determined internally by banks because products with volatile exposure are specific to banks and are not (yet) rated by external agencies. CCF ratings provide an ordinal ranking of the credit consumption on off-balance sheet items. They can be complemented with CCF rates specifying the cardinal measures of credit usage. Compared to default and recovery ratings, methods to derive CCF ratings are still in their infancy. Further developments in this area are expected in the near future catalyzed by the Basel II Capital Accord.

#### 3.4.4.4 Expected loss ratings

Default risk and recovery risk provide different perspectives on credit risk. Both<sup>15</sup> can be merged into one overall risk measure that is called expected loss (EL). Suppose one has two debt obligations, one collateralized obligation with a bad default risk and one non-collateralized obligation with a good default risk. Both essentially pose the same risk in terms of expected loss. Expected loss is hereby defined as

$$\text{EL} = \text{default rate} \times (1 - \text{recovery rate}),$$

or in a Basel II context,

$$\text{EL} = \text{PD} \times \text{LGD}.$$

<sup>15</sup> In the case of important exposure risk, the expected loss also includes exposure ratings.

The EL measures the average losses occurred due to default in a portfolio, over a specific time horizon. Quantifying EL is becoming more and more important since it is one of the key inputs for loan loss provisioning, pricing and other credit policies. Where necessary, the EL measure is complemented with exposure risk information. Expected loss measures are then compared with respect to the credit line or current exposure.

EL ratings provide an opinion on the expected loss measured on an ordinal/cardinal scale and can be encoded in two ways [350].

1. The first approach entails the merging of the default and recovery rating in one composite EL rating. For example, using S&P terminology, an EL rating BB4 would indicate a BB-rated default risk and a recovery risk of 4.
2. The second approach is to use lookup matrices that assign the same EL rating to different combinations of default and recovery risk having identical expected loss. This is illustrated in Table 3.6, where 6 default ratings and 5 recovery ratings are used to derive an expected loss rating between EL1 and EL8 as the table shows. Multiple PD and RR combinations result in a similar EL rating.

Moody's long-term issue ratings essentially capture both default risk and recovery risk and hence are an example of expected loss ratings [233]. In Table 3.4, we provide an overview of the average cumulative expected loss rates calculated by Moody's for firm bond issuers observed during 1920–2005 [233]. Just as default risk is monotonically increasing when going down the rating scale, it can also be observed that expected loss increases for lower ratings. In other words, one may argue to use the same rating scale

**Table 3.6** Expected loss (EL) lookup matrix [350]: the EL rating (EL1, ..., EL8) is obtained for certain combinations of default risk (PD1, ..., PD5) and recovery risk (RR1, ..., RR5). The exposure risk dimension is omitted here for the sake of conciseness.

PD	LGD				
	RR1	RR2	RR3	RR4	RR5
PD1	EL1	EL1	EL2	EL2	EL3
PD2	EL2	EL2	EL3	EL3	EL3
PD3	EL2	EL3	EL4	EL4	EL5
PD4	EL4	EL4	EL5	EL5	EL6
PD5	EL5	EL5	EL6	EL6	EL7
PD5	EL6	EL6	EL7	EL8	EL8



**Table 3.7** Moody's senior ratings algorithm notching matrix [99, 231].

Bond Rating	Senior Unsecured/			Bond Rating	Senior Unsecured/		
	Senior Secured	Issuer Rating	Sub-ordinated		Senior Secured	Issuer Rating	Sub-ordinated
Aaa	-1	0	0	Ba1	-1	0	1
Aa1	-1	0	1	Ba2	-2	0	1
Aa2	-1	0	1	Ba3	-2	0	1
Aa3	-1	0	1	B1	-2	0	1
A1	-1	0	1	B2	-2	0	2
A2	-1	0	1	B3	-2	0	2
A3	-1	0	1	Caa1	-2	0	2
Baa1	-1	0	1	Caa2	-2	0	2
Baa2	-1	0	1	Caa3	-2	0	2
Baa3	-1	0	1	Ca	-1	0	2
				C	0	0	2

for both default risk and expected loss. However, the use of the same scale for issuer PD and issue EL ratings may cause confusion. Moody's reports issuer default rates for the senior unsecured issue rating, which serves as the reference issuer rating [99, 231].

An approach that is commonly adopted is to define issue expected loss ratings starting from the issuer default rating and notching it up or down taking into account the seniority. When the senior unsecured rating is equal to BBB, but the recovery risk is very limited due to collateral, the expected loss rating is obtained by improving the rating, e.g., with 1 notch to BBB+. In the case of a subordinated bond, the expected loss rating is obtained by notching the BBB down to, e.g., BBB-. The rating agencies have defined several notching up and down schemes. One such scheme is the Moody's senior ratings algorithm<sup>16</sup> reported in Table 3.7 [99, 231]. Notching schemes are defined by many rating agencies.

In the past, many banks adopted one-dimensional rating systems focusing either solely on default risk (hereby ignoring recovery risk) or focusing on expected loss [350, 479]. Since the Basel II regulation has disaggregated credit risk into default risk, recovery risk and exposure risk, these one-dimensional rating systems are more and more being replaced with

<sup>16</sup> These senior unsecured ratings must not be confused with senior implied ratings. Moody's also has defined senior implied ratings that are applied to speculative grade firm family assuming a single class of debt and consolidated legal entity structure.

multidimensional rating systems providing distinct default, recovery, CCF and expected loss ratings.

### 3.4.5 Local and foreign currency ratings

Consider a bond issued by a firm in the local (home) currency and a bond issued by the same firm in a foreign currency (US\$, Euro, . . .). Although both investments are from the same issuer, they bear a different default risk. Sovereign government policies may restrict the access to foreign exchange needed for fulfilling foreign obligations on a timely basis. This is often referred to as transfer risk and should be taken into account when issuing credit ratings in an international context. Transfer risk is described in more detail in section 3.4.11. Therefore, the local currency denominated bond is less risky than the foreign currency denominated bond, which explains the distinction that is made between local currency and foreign currency ratings [109]. Often, the foreign currency rating is obtained by applying the country rating as a cap to the local currency rating.

For non-sovereign entities, a local currency rating evaluates an obligor's capability of generating sufficient local currency in order to meet its domestic currency financial obligations. It excludes the transfer risk that is relevant for foreign currency obligations, but may still include other sovereign risks, a.o., risk of systemic financial distress in the country. When considering foreign currency obligations that receive a local currency rating, the risk of access to foreign exchange is assumed to be unrestricted.

For non-sovereign entities, a foreign currency rating evaluates an obligor's ability to service foreign debt commitments taking into account the access to foreign exchange, controlled by central banks or central monetary institutions. Non-sovereign foreign ratings are normally lower than their local counterparts, because they reflect potential access limitations to foreign exchange and take into account the transfer risk.

For sovereign entities, a local currency rating reflects the sovereign's ability and willingness to service debt expressed in the local currency, whereas a foreign currency rating considers only foreign debt. In a sovereign context, local currency ratings are typically higher than or equal to foreign currency ratings, reflecting a government's greater willingness and ability to service debt in the local currency by appropriate tax or monetary interventions. Note, however, that because of globalization and currency unification, the difference between the two seems to diminish [387]. Local and foreign currency ratings are internationally comparable.

### 3.4.6 National scale ratings

National scale ratings denote the quality of the issuer/issue relative to others within a specific home market. The quality is measured relative to the best credit risk quality in a given country across all industries and obligation types. In most cases, the best credit risk is obtained by the state.

The country of the home market is indicated in the rating, e.g., by adding “mx” for Mexico. National scale ratings are available for short- and long-term assessments. These ratings are comparable within countries or currency zones, but not across different ones.

### 3.4.7 Stand-alone ratings

Stand-alone ratings or individual ratings reflect the issuer’s financial strength and creditworthiness without any intervention from the state, shareholders or stakeholders. These ratings are applicable to almost all counterpart types and are especially important for banks, which are likely to receive some sort of support in case of financial difficulties.

Financial strength, stand-alone or individual bank ratings give an assessment of the bank on a stand-alone basis, if it were entirely independent and could not rely upon external support from shareholders or the state. The individual rating analysis looks at the profitability, capitalization, asset quality, operating environment, diversification and management. These ratings are expressed on a specific scale with 5 main categories: A (very strong), B (strong), C (adequate), D (weak) and E (serious problems). More refined gradations are assigned by rating modifiers (A– to E+) and in-between values (A/B to D/E).

### 3.4.8 Claims payability and deposit ratings

Insurer ratings are ratings providing a view on the ability of an insurance organization to fulfill its insurance policies and contracts under the agreed terms. As for banks, regulation for insurance companies will be improved by the introduction of the Solvency II agreement. The process of analyzing the claims payability to the customers is different from the issuer credit rating that evaluates the quality of debt repayment ability. The S&P insurer financial strength rating exists on a long- and short-term basis. Financial enhancement ratings are defined in an analogous way for financial guarantors and credit enhancement institutions.

Fitch quantitative insurer financial strength (Q-IFS) ratings depend only on the quantitative information and are assigned by a statistical model that uses financial statement information. Such ratings receive the qualifier “q”.

Bank deposit ratings give an opinion on the punctual repayment ability of foreign and/or domestic currency deposits. These ratings have a similar interpretation for banks as the claims payability ratings for insurance companies. Instead of rating the debt, the investment risk of deposits is analyzed. Bank deposits have a similar role to insurance contracts.

### 3.4.9 Municipal ratings

Municipal ratings express an opinion on the investment quality of US municipal and tax-exempt issuers and issues. The main drivers of the municipal ratings are the strength of the local economy, tax basis, debt structure, finance and management quality. The long-, medium- and short-term ratings are expressed using similar ratings as for firms, but municipal and firm ratings are generally not comparable. Municipal issuers and issues bear typically lower credit risk than firm issuers and issues with the same rating label.

### 3.4.10 Support ratings

Being crucial players in a country’s economy, banks may typically rely on safety nets when facing financial difficulties. Examples of this are support provided by the institutional owner (e.g., mother company) or the sovereign government. As indicated in Table 1.5, supervisors and government regularly provided some sort of support, either by guaranteeing deposits and/or bonds, in past banking crisis. That is why many credit agencies complement the stand-alone bank rating with a support rating, providing an assessment of the propensity of receiving external support, and the quality thereof.

Support ratings indicate a judgment of a potential supporter’s propensity and ability to support a bank facing difficulties. Support ratings provide a floor to the bank’s long-term rating, but are not related to the individual rating. Support ratings are assumed to be applicable to most obligations, except capital-related obligations like preferred shares, hybrid capital and capital. The support rating depends on the willingness or propensity and ability to give support. The willingness of the state to give support is influenced by the importance of the bank to the state and the economy, the type of services provided, the percentage of shares owned by the state, etc.



the support matrix. Fitch has defined 5 support ratings:

- 1: Extremely high probability of external support by a very highly rated support provider. A support rating 1 indicates a minimum long-term rating floor of A–.
- 2: High probability of external support by a highly rated support provider. A support rating 2 indicates a minimum long-term rating floor of BBB–.
- 3: Moderate support probability because of uncertain propensity and/or ability. A support rating of 3 indicates a minimum long-term rating floor of BB–.
- 4: Limited probability of external support because of significant uncertainties on propensity and/or ability. A support rating of 4 indicates a minimum long-term rating floor of B–.
- 5: External support is possible, but cannot be relied upon. The long-term rating floor is not higher than B– and, in many cases there is no floor at all.

In the case of very high propensity, the daughter company receives the rating of the mother company. This is also known as full branch equivalency. Older rating schemes use the traditional notching up of the daughter rating such that the resulting rating is in between the mother rating and the daughter stand-alone rating.

Support ratings are positive for the long-term rating. A floor on the long term rating is provided. The relation between mother and daughter companies may also be negative in the case when the mother has higher credit risk than the daughter. The mother company may try to draw cash from the daughter in case it faces financial difficulties itself. This is known as negative support and is less likely than positive support. For banks and insurance companies, negative support can be limited by national regulation.

### 3.4.11 Country and country ceiling ratings

Sovereign credit ratings reflect a country's ability and willingness to service and repay its external financial obligations [102, 120, 262, 314]. They may also reflect the risk of a major economic crisis and joint default of multiple obligors in the country. Consequently, these ratings represent a country's relative credit risk and serve as an important guideline for foreign investments and financial decisions. A strong credit rating creates a financially favorable climate, whereas a low credit rating usually leads to a reversal of capital flows and an economic downturn. Hence, a good country rating is a key

success factor for the availability of international financing for a company since it directly influences the interest rate at which countries can borrow on the international financial market. Also, the sovereign credit ratings directly impact the ratings of the country's banks and companies, i.e. when a country's rating decreases, this is often also the case for the ratings of the country's banks and companies [167]. Moreover, sovereign credit ratings seem to have a correlation with national stock returns and firm securities [296].

A sovereign in financial difficulty may take actions to prevent or materially impede the private sector from transferring money to non-resident creditors or to convert local currency to foreign currency risk. A sovereign that faces an external debt crisis has the power to impose a payment moratorium and to limit foreign currency outflows, including debt payments of all issuers domiciled in that country. The moratorium can prohibit healthy companies and individuals from honoring foreign debt obligations.

The country ceiling rating reflects the transfer and convertibility risk prohibiting issuers to meet external payment obligations in a timely matter. It acts as a rating ceiling on the long-term ratings of the residents of the country. The country ceiling rating used to be equal to the country rating in the past. Sovereign defaults were typically accompanied by a payment moratorium. However, recent data reveals that a sovereign default does not necessarily imply a payment moratorium, such that the country ceiling rating is above or equal to the country rating. The country ceiling rating is derived from the probability that a sovereign default occurs, the probability that a payment moratorium occurs and that the debt service of the issuer or issue is included in such a moratorium [481]. It is considered that a moratorium is not automatically applicable because of the internationalization of the economy, the integration of local economies into the world economy and laws supporting the integration making a moratorium more difficult to apply. An important example is a currency zone, like the Euro, in which the risk of a moratorium is significantly reduced. Other factors that impact moratorium risk are the costs involved compared to other policy alternatives and the appetite of the government to absorb the credit risk of its major companies facing payment problems. The latter may occur, e.g., because of a rapidly depreciating exchange rate.

Country ceiling ratings are essentially applied to foreign currency risk because there the transfer and moratorium risk is the highest. Nevertheless, a moratorium risk can also be applied internally in the country. As such, a local currency ceiling rating needs to be defined and applied to local currency ratings of firms.

Country ceilings are important for domestic banks that are highly vulnerable to a national sovereign crisis. However, the ceiling may not be applicable to offshore banks or banks operating mainly abroad, as these banks may be higher rated than their domestic sovereigns [464]. Note that some credit agencies rate a financial institution using a different long-term debt rating and a bank rating, although the difference between them is sometimes debated [398].

When a counterpart receives a rating higher than the sovereign rating, the rating is said to pierce the country ceiling. The debate of country ceiling is still ongoing because the moratorium no longer occurs together with a sovereign default.

### 3.5 Rating system architecture

The generic rating system architecture to assign a PD rating is depicted in Fig. 3.3. In a first step, the stand-alone, individual or financial strength rating is assigned by the rating model based upon financial variables (e.g., from financial accounts and statements) and qualitative variables. Some of these qualitative variables are judgmental variables (e.g., management quality and

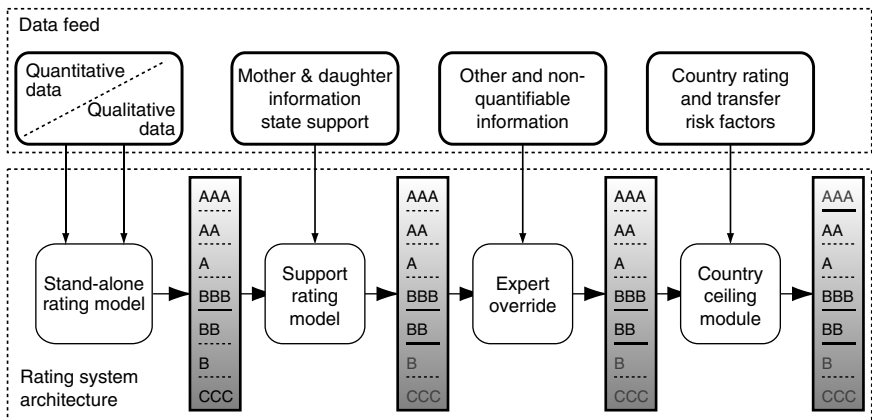

**Fig. 3.3** Generic architecture of a PD rating system. In the first step, the financial strength, individual or stand-alone rating is determined by the stand-alone rating model based upon quantitative financial and qualitative information. The support floor rating is based upon mother and daughter company relations and the propensity and willingness of the state. The resulting rating is adjusted by the financial experts based upon additional information that is not taken into account in the model or that is difficult to quantify, although the impact of the override is typically limited to ensure objectivity of the rating. The final rating is obtained by capping the result with the country ceiling rating.



financial flexibility). The rating model yields the individual rating in one step or in two steps, where first the quantitative rating and in the second step the quantitative and qualitative rating is assigned.

In a second step, support from the mother company or from the state is combined with the individual rating. The individual rating inclusive support can be implemented by applying a support floor to the individual rating. The support floor can be taken from the highest support rating of the mother and state. Each support rating depends on the ability and the propensity of the supporting entity as explained in Table 3.8. The propensity depends on the supporting entity, the support-receiving entity and the relations between them. More complex support logic modules combine stand-alone default and support probabilities. The combination of the stand-alone rating and support is mainly a pure mechanical, model-based rating.

The mechanical model rating is then adjusted by the human expert or by a committee. The override on the model rating is done within a narrow range of the mechanical model rating. The override takes into account elements that are difficult to quantify and to use in a model or that are too specific to take into account in a model. Negative support may be too exceptional for a sector to build a separate module and is taken into account in the override part. Pending legal disputes or important market changes can be important enough to motivate an override. The override is typically limited in a sufficiently narrow range to ensure rating objectivity, coherence and consistency across different issuers. Larger deviations certainly need stronger motivation and approval from internal rating-control committees.

In a final step, the country ceiling rating is applied to take into account the transfer and convertibility risk. It is common practice to apply the country ceiling as a rating ceiling. The country ceiling rating depends, in most cases, only on country and currency characteristics. In some cases, specific mechanisms like offshore constructions are applied to reduce possibilities to control financial flows by the government and, hence, the country ceiling is not applicable. In such cases, the country ceiling rating depends on both the country characteristics, properties of the offshore construction and the counterpart. More advanced country ceiling modules combine different probabilities (issuer, country default, moratorium probabilities).

Figure 3.3 represents a generic rating system. Practical rating schemes put more or less emphasis on the different steps. Automatic rating schemes will not make use of override procedures, or only for borderline cases as in Fig. 2.2. For new sectors and issuer types or sectors with only a limited number of counterparts or financial information, the expert part will be more

important. Other deviations of the generic scheme are the use of different rating scales in-between the different steps (e.g., the financial strength rating of banks) and the choice of the exact order of the different steps. Basel II encourages the country ceiling at the end<sup>17</sup> of the rating process, to ensure that the country ceiling is effectively applied.

The expected loss ratings will follow a similar rating scheme. An additional notching up and down phase takes into account the seniority of the issue and additional recovery prospects (see, e.g., Table 3.7). Notching up and down schemes are sometimes also applied for holding companies that are not involved in commercial or operational activities and as such bear higher credit risk.

For LGD and CCF ratings, similar schemes hold as well. For an LGD rating system, one combines different financial variables and collateral information to obtain an analytical LGD rating. The LGD rating assignment can be split up into an unsecured LGD and an LGD after the impact of collateral as explained in the next chapter. In a final step, expert overrides can take into account specific elements, while an additional module may take into account the impact of guarantees.

## 3.6 Rating philosophy

Rating philosophy refers to the time horizon for which the ratings measure credit risk, and hence to how much they are influenced by cyclic effects [3, 63, 248].

### 3.6.1 Point-in-time and through-the-cycle ratings

Two broad rating philosophies can be distinguished. In a point-in-time (PIT) rating system, the ratings measure credit risk over a relatively short time period (e.g., 1 year), and are as such greatly influenced by temporary shocks or cyclical effects in the borrowers's condition. The importance of the difference between both systems is clear from Fig. 3.1a. PIT ratings are reactive and change as soon as a debtor's risk profile changes, due to cyclic or non-cyclic effects. When using PIT systems, the general economic situation will be directly or indirectly reflected in the credit assessment. A possible

<sup>17</sup> In some cases, it may fit better into the bank's organization to put the override before the expert override and allow for piercings of the country ceiling.

approach is to make the rating explicitly dependent on macroeconomic factors or on predicted<sup>18</sup> sector risk measures. Models for predicting sector default rates have been reported in [192, 288, 305]. PIT ratings are particularly applicable for short-term transactions and volatile sectors or regions, like in developing countries (where most exposures are short to medium term).

In a through-the-cycle rating (TTC) system, the ratings measure credit risk over a longer time horizon (e.g., 5 years or more) during which cyclic effects have been filtered out. TTC ratings are relatively stable and only change when changes in a debtor's risk profile are likely to be permanent. Through-the-cycle ratings are supposed to remain stable throughout the economic cycle and evaluate the risk during sufficiently adverse circumstances of the cycle. Knowing the risk philosophy adopted by a rating agency or a financial institution is important for the evaluation of the rating systems. When contrasting observed default rates with a-priori estimated ratings and default rates, one has to assess whether any observed differences are due to cyclic effects and whether these cyclic effects are supposed to be captured by the ratings or not. Furthermore, when benchmarking rating systems of different parties, it is important to know the rating philosophies adopted, in order to make the comparison meaningful and reliable.

### 3.6.2 Philosophy for rating types

The rating philosophy has to be determined for all types of ratings: default, recovery, exposure and expected loss ratings. Default rates are known to depend a lot on the economic cycle, at least for some asset classes. Figure 3.1a reports the historical evolution of the default rates for large firms.

Recovery rates are reported to depend also on the economic cycle and are generally known to be lower during downturn conditions if a dependence exists. Such a dependence has been reported for large firm bond issues when the market LGD is derived from the bond price sold at the market one month after default. It is still a discussion point whether such dependencies also hold for other LGD types<sup>19</sup> (e.g., workout LGDs) and for other asset classes.

<sup>18</sup> As will be explained in Book II, such predicted variables can be obtained by time-series prediction, where some formulations predict the future based upon past values and dynamics.

<sup>19</sup> An overview of the different LGD types is provided in the next chapter.

For exposure risk, a similar downturn effect may apply. During recession periods, companies may have more liquidity needs and may be tempted to use a larger portion of the credit lines.

### 3.6.3 External and internal ratings

Ratings provided by rating agencies are typically TTC ratings based on an undefined long-term perspective on credit risk [17, 18, 452]. From a regulatory perspective, stable TTC ratings are preferred. When using PIT ratings that are sensitive to cyclic changes in the borrower's credit risk, risk levels and corresponding capital requirements tend to increase during recession periods and to decline during economic expansions. Because of increasing (regulatory) capital requirements, during downturns, banks tend to restrict lending activities or to increase price margins, both reducing funding opportunities. The economic downturn may be exacerbated by reduced funding due to increasing capital requirements from PIT rating systems. This phenomenon is referred to as procyclicality [9, 214, 390]. Empirical evidence suggests already that banks, for various reasons, reduce lending more than the reduction of economic activity during downturn. Therefore, procyclicality has been a key attention point in the development of the Basel II capital rules that clearly advise TTC ratings.

Rating stability is also a desired characteristic by investors that like to keep their portfolio composition stable. However, at the same time, many investors criticize rating agencies for being too slow in adapting their ratings. They want ratings to reflect recent changes in default risk so as to be able to react appropriately and in time [162]. Of course, achieving rating stability and timely ratings are both conflicting in nature. The discrepancy is subject to intense discussion and research (see, e.g., [17, 18, 162]).

In contrast, many of the internal rating systems built by financial institutions are PIT systems measuring credit risk taking into account the current conditions and situation of a borrower [350, 479]. This makes the comparison between internal and external ratings more complex.

#### 3.6.3.1 Mapping rating types

When benchmarking a financial institution's PIT ratings with TTC ratings of a rating agency, a mapping methodology needs to be worked out that is dependent upon the stage in the business cycle. Aguais *et al.* [3] developed an approach to convert agency TTC ratings into PIT representations of one-year

default rates:

$$\text{Rating}_{\text{TTC}} = \text{Rating}_{\text{PIT}} + f_{\Delta}(\text{PD}_{\text{av}}, \text{PD}_t). \quad (3.1)$$

The difference between the TTC and PIT rating is explained by the difference between the long-term average  $\text{PD}_{\text{av}}$  and the short-term  $\text{PD}_t$  measured at time  $t$  on the last month or the last year. The formula for the difference<sup>20</sup> is based upon the expression (5.24) used in the regulatory capital formula, as explained in Chapter 5.

It is important to remark that the difference between TTC and PIT rating systems is subject to a lot of controversy and debate in the literature and industry. No consensus has been reached yet regarding their exact definition and differences. This may be explained by the fact that it is hard to define what constitutes a credit cycle for many portfolios, meaning that the time horizon against which TTC ratings should be modelled, is often vaguely defined. Hence, a TTC system may incorporate cyclic effects up to a moderate extent, thereby basically giving them a PIT flavor. Some rating agencies allow a limited impact of current economic conditions on their TTC ratings. In other words, it is hard to qualify a rating system as pure TTC or pure PIT, since both represent extremes of a continuum with many hybrids in between [248]. Knowing towards which end of the continuum a rating system is situated, is, however, important because of the reasons mentioned above.

### 3.7 External rating agencies

A credit rating agency analyzes the creditworthiness of issuers and issues and publishes its results for the investment community. It serves as an information intermediary that provides easy and reliable estimates of the credit risk. Such information is highly valuable for investors that save costly time and can invest according to their risk appetite. External ratings improve the efficiency of the market, lowering costs for investors and debt issuers. Their role has gained importance by the increasing disintermediation since the 1980s. Bank debt has been replaced by publicly rated debt issues.

External ratings are assigned by credit rating agencies, of which the most popular are nowadays Moody's, Standard and Poor's, and Fitch. Ratings of

<sup>20</sup> The difference between  $\text{PD}_{\text{av}}$  and  $\text{PD}_t$  is expressed by the systematic factor  $\eta$  from eqn (5.24):  $\eta = [\Phi_N^{-1}(\text{PD}_{\text{av}}) - \sqrt{1-\varrho}\Phi_N^{-1}(\text{PD}_t)]/\sqrt{\varrho}$ , where  $\varrho$  indicates the asset correlation. The estimated systematic factor  $\eta$  is then introduced in the function  $f_{\Delta}$  on the difference between the ratings or to correct the underlying PIT/TTC scores of the ratings.

publicly issued bonds were first produced during the early 1900s by predecessors of the current major agencies. The major agencies have a broad coverage across different geographical zones and product ranges. The three major agencies are predominantly present in the US market and to a lesser extent in Europe and other markets. In the decades after 1920, other agencies, both domestic and foreign, were formed and commenced publication of ratings. The total number of agencies is around one hundred. The market of rating agencies is still evolving. In the recent history, Moody's and K.M.V. merged into Moody's K.M.V. and Duff & Phelps merged with Fitch [421]. The limited number of rating agencies is explained by the competition, the globalization and the high entry barriers in the market. Both reputation and regulatory aspects are important barriers for new entries in the rating market [511]. Rating agencies assessments and changes of the risk assessment have an important impact on bond prices and interest rates [286], partially because of regulatory implications.

The larger rating agencies cover a large proportion of large debt issuers, while local rating agencies cover local markets and smaller issuers, e.g., with statistical and automated rating systems. These local agencies add information for the investors, e.g., for pricing purposes [386].

### 3.7.1 Moody's, Standard & Poor's and Fitch

Moody's, Standard & Poor's and Fitch are the three global rating agencies that form the core of the credit rating industry. A short summary of them is given below.

Moody's was founded by John Moody (1868–1958) in 1900, the same year John Moody & Company published *Moody's Manual of Industrial and Miscellaneous Securities*. The manual contained statistics and information on stocks and bonds. The manual company did not survive the 1907 stock market crash, but John Moody returned in 1909, offering analyses of security values instead of just collecting information. His conclusions were expressed via letters from mercantile and credit rating systems used by credit reporting firms near the end of the nineteenth century. Starting with the analysis of railroad investments in 1909, the base of companies was expanded in 1913. In 1914, Moody's Investors Service was incorporated and the coverage was extended to municipal bonds. In 1924, Moody's ratings covered almost the full US bond market. Ratings were assigned unsolicited based upon public information. A key driver of Moody's reputation was the low number of defaults during the Great Depression for its higher-rated bonds.

Extensions of the rating service included the commercial paper market and bank deposits. Moody's has a very strong market position in the US and also Europe. Its global coverage is increasing, especially on the Asian market. Moody's was acquired by Dun & Bradstreet Corp (D&B) in 1962. It was spun off in 2000 and it is now stocklisted on the New York Stock Exchange (NYSE). As of 2001, Moody's covered over US\$30 trillion of debt issuances and counted 1700 employees that generated yearly about US\$800 million revenues. Moody's is the only publicly owned rating company discussed in this section. In 2002 it acquired K.M.V. that, a.o., provides quantitative ratings. After the merger, both the names Moody's and Moody's K.M.V. are used.

Henry Varnum Poor published his *History of Railroads and Canals of the United States* in 1860. Poor's company provided financial information to investors. The Standard Statistics Bureau was created in 1906 to provide financial information as well. Ratings of firm and sovereign debt were assigned from 1916 onwards. The credit analysis of Standard and later Standard & Poor's expanded to municipal bonds, commercial paper, sovereign debt, mortgage and asset based securities, loan-anticipation notes, project finance, bond insurance, . . . In 1941, Poor's Publishing and Standard Statistics merged to form the Standard & Poor's Corporation. In 1966, S&P was acquired by the McGraw-Hill Companies, a leading global information provider. In 2001, the total amount of debt covered exceeded US\$11 trillion. S&P has an important market share in the US and also Europe. Its global coverage is also expanding, especially in Latin-America. Apart from the credit ratings, S&P also provides other information services to the financial community, e.g., on equity research and financial databases. A well-known stock index is the S&P500 index of US stocks.

Fitch Ratings, Ltd. is the third major rating agency. It has dual headquarters in New York and London. It was founded by John Knowles Fitch in 1913 as the Fitch Publishing Company in New York. The company began with publishing financial information and providing financial statistic publications. The "AAA"–"D" rating scale was introduced in 1924. Like Moody's and S&P, Fitch ratings became an important benchmark in the financial community. In 1989, the company was recapitalized by a new management team. Fitch grew significantly in the 1990s, a.o., on the market on structured products. Fitch also grew by mergers and acquisitions to provide a global, worldwide rating service. The merger with the UK-headquartered IBCA strengthened the coverage on banks, financial institutions and sovereigns. In 2000, it acquired Duff & Phelps (Chicago) and Thomson Bank Watch

(New York) to further improve its sectorial and geographical coverage. Fitch has 3 main divisions: the rating service (Fitch Ratings), training (Fitch Training) and consultancy/advisory (Algorithmics). The French holding company Fimalac owns the majority of the shares. Fitch is less strong in the US but improved its global coverage through its acquisitions. Fitch has a strong coverage in Europe. The 1200 employees generated about US\$260 million revenues in 2000.

### 3.7.2 Other rating agencies

There exist about 100 other rating agencies that operate on a more local and sector-specific scale. The local agencies complement the global players. Important regional rating agencies exist in Japan, Sweden, Italy, Germany, Canada, India, China, Malaysia, Korea, Russia, Pakistan, . . . In developing markets, new rating agencies also appear, while the global agencies expand their coverage via setting up local branches, acquisitions and co-operations with local agencies. Despite the large number, the number of agencies remains limited per country or jurisdiction. The rather limited number of rating agencies outside the US is explained by a less developed bond market in the past and by the efforts of the big three agencies to operate globally [169].

Among the larger ones, there are A.M. Best, Canadian Dominion Bond Rating Service and Dun & Bradstreet Corp. A.M. Best was founded in 1899 by Alfred M. Best in New York. It is specialized on financial strength ratings of insurance companies in many countries. The Canadian Dominion Bond Rating Service was founded in 1976 and is a leading credit rating agency in Canada. It also operates on the US market, but is significantly smaller than the three big rating agencies. Dun & Bradstreet Corp (D&B) has been discussed in the previous chapter.

Most credit agencies use the long-term rating scale with “AAA” to “C” labels, but this is not a general rule. Other scales may be used, e.g., labels ranging from “5” to “1”, “A+” to “C”, “1” to “1000”. A general consistency is that most rating agencies provide an ordinal risk measure. A comparison of these ordinal ratings yields that they may have changes in absolute levels, but not too much in the relative rank ordering. The rating philosophy adopted by most is the through-the-cycle philosophy. Point-in-time ratings are assigned by only a few raters, e.g., by K.M.V. that was acquired by Moody’s. When absolute risk levels are assigned, most are based upon (proprietary) statistical models that are more suitable for this task.



Local agencies will play an important role to increase efficiency of local capital markets [386]. Some of the local agencies already co-operate with the three big agencies [169, 449].

### 3.7.3 Rating process

The rating process of the major agencies follows essentially the rating scheme of Fig. 3.3. An important focus is on the human expert part, which is obtained from a detailed analysis by a team of professionals that exchange ideas with and ask questions to the management of the issuer, a.o., during on-site visits. Such a rating process is supervised by the leading analyst, who is responsible for the whole process.

A solicited rating is assigned by the rating agency based upon all possible information, both public and confidential in nature. Public information includes financial reports and statements of the company, interim reports; industry, sector and economic reports. Confidential internal information from the rated issuer is obtained by contacts with the management and senior executives. Based upon all the information, the rating analysts formulates his findings and presents them to the rating committee, which decides upon the final rating. The rating committee consists of the leading analyst, analysts on the same and other sectors and senior executives of the rating agency. A main role of the rating committee entails consistency of the ratings. The proposed rating decided by the committee is communicated to the rated issuer or issue, who has the possibility to discuss the proposed rating and the corresponding report.

At the end of the process, the resulting rating is published and followed up internally. The rating process becomes a continuous surveillance task. Through-the-cycle ratings do not require as important follow-ups as point-in-time ratings, reviews are triggered mainly because of important business, economic, financial or operational events.

Unsolicited ratings are assigned with limited access to public information only. It remains unclear whether unsolicited ratings have the same quality and are not biased downwards [388]. Would a company intend to pay when a solicited rating were lower than an unsolicited rating? For some types of ratings, like pure quantitative ratings, such information is not used by the model. In these cases, the whole asset class receives the same type of rating and there is no issue of a potential bias or quality difference between solicited and unsolicited ratings. Market-implied ratings are based only on market information and provide an assessment of the market perception of the credit quality.

### 3.7.4 Revenues

At the beginning of the twentieth century, the agencies' revenues came entirely from the sale of publications. The growing importance of credit ratings in the capital market,<sup>21</sup> the increasing complexity and efficient information systems, led the rating agencies around 1970 to charge rating fees for rated issuers and issues. Whereas most ratings are public, it is no longer possible to charge for such information. The main rating agencies sell publications to subscribers and provide automated access to rating information for "soft" prices.

The three major agencies receive important revenues from fees paid by the debt issuers. The fees consist of recurring fees for rating surveillance and one-shot transaction-based fees that act as a couple of basis points of the nominal amount, with minimum and maximum values. In [199, 479] the listed fees required by Moody's and S&P are 3.25 basis points (0.0325%) for issues up to US\$500 million with a cap at US\$125,000 (S&P) and US\$130,000 (Moody's), respectively. For issues above 500 million, one charges 2 basis points. S&P also charges a one-time fee of US\$25,000 for first-time issues. Fitch is generally reported to charge lower fees, around 2 bps (0.02%). Frequent issuers probably negotiate significant discounts to the listed prices. Their oligopolistic position could tempt rating agencies to increase their prices, but at the same time competition and customer-base reductions may restrain agencies from too aggressive pricing. The prices indicate the amount of resources agencies put in place to rate issuers. For 2001, Moody's reported a net income after tax of US\$212 million, compared to about US\$800 million revenues. Unsolicited ratings are assigned to the largest companies based upon publicly available information only and no fee is required. The concerned issuers are, however, invited to provide more information and to pay for a solicited rating. Where ratings are part of the regulatory process, the fees charged by the agencies are part of the regulatory burden [449].

Local and smaller rating agencies may charge customers as well as subscribers. Their ratings are not publicly disclosed and are sold directly to investors. In many cases, the ratings are assigned by automated rating systems of which the results and possibly the model is sold to investors, optionally together with information and database systems. The cost of such unsolicited ratings is sufficiently low to make a profitable business from subscription revenues only.

<sup>21</sup> Some important defaults occurred at that time and put increased attention of investors onto credit risk. As a result, issuers asked for more ratings to reassure nervous investors.

### 3.7.5 Critics on credit ratings and rating agencies

Being paid by the rated issuer, there may arise possible conflicts of interest because the agency has to assign a correct and independent rating while being paid by the rated issuer or issue [200, 449]. Given the increased importance of ratings, conflicts of interest may arise at various points and become exploited.

A first example conflict of interest is the reliance of the agency on issuer fees. The issuer needs to pay the agency in order to receive a rating. Given this relationship, there may be a potential danger in giving the issuer an overly optimistic rating in order to ensure its retention. This conflict of interest may be further amplified by the fact that rating agencies start offering more and more consulting and advisory risk management services. Note that in this context, the 2002 Sarbanes–Oxley (Sarbox, Sox) act encourages firms for sound firm governance, enhanced financial disclosure, internal control assessments and auditor independence [88, 217, 259].

Issuers may put pressure on the chosen rating agency to assign a higher rating, rating agencies may start to give higher ratings as part of a marketing strategy to specific sectors or countries, rating agencies may charge higher fees for a better rating or rating agencies may assign lower ratings for unsolicited ratings [101, 449]. In [101] it was observed that the third rating agency assigned often an investment grade rating when the other two disagreed on investment and non-investment grade before. A common criticism regarding unsolicited ratings is that they tend to be less favorable and can be interpreted as a pressure on companies to tell their financial story and pay the fee for a solicited rating [388].

Conflicts of interest may also occur because issuers may shop for the most favorable rating agency. Since credit ratings are serving more and more as key inputs for risk management strategies (e.g., regulatory capital calculation in a Basel II context), financial institutions can start cherry-picking the agencies according to the most favorable and advantageous credit rating, resulting in the desired risk management strategy. Regulators are becoming more and more aware of this and try to circumvent such practices by introducing appropriate<sup>22</sup> legislation.

From an investor perspective, rating agencies have been reported to react rather slowly in adjusting their ratings to changes in credit quality

<sup>22</sup> For example, in section 6.3.1.1.B.1, the Basel II rules are discussed on which rating to apply in the case of split ratings.

[17, 35, 162, 185, 323]. This can be partly explained by the TTC rating philosophy, whereby less weight is put on short-term credit quality fluctuations. However, this attitude has raised many questions. It is also often referred to as rating stickiness and is not appreciated by investors with short-term gain perspectives [136].

The credit rating industry is very concentrated with the most important players being Moody's and Standard & Poor's. This oligopolistic market structure can be partly explained by the entry barriers for newcomers [449]. In order to be successful, a newcomer needs to build up and maintain a credible reputation, which is of course very time consuming and requires substantial investments. This reinforces the position of the few existing market players, which may make them too powerful. An example of this is the controversial issue relating to the assignment of unsolicited ratings [200]. By assigning unsolicited ratings, credit agencies may force counterparts to subscribe and hence pay for their services, in order to get a more favorable, solicited rating based on the conveyed information. This has already led to a number of lawsuits in the past and remains a subject of debate.

Given the aforementioned criticisms, it is of crucial importance that credit agencies themselves are subject to external review and regulation. An example of this is the code of conduct issued by the International Organization of Securities Commissions in 2004 that outlines the basic principles credit agencies should adhere to in order to avoid conflicts of interest [278]. In the Basel II Capital Accord, a set of well-articulated criteria are put forward to which credit agencies have to conform, in order to be eligible for being used for regulatory capital calculation purposes.

The importance of reputation for rating agencies is a strong control mechanism that avoids these conflicts of interest being systematically exploited. The quality and perception of ratings is built upon a long history of practical evidence. The loss of reputation may impact the rating agency fatally. Supervisors may restrict or even decertify the use of the concerned agency's ratings for regulatory issues. Investors would lose confidence in the ratings and debt issuers no longer have a benefit to pay for a rating of the concerned agency. The agencies' have internal mechanisms to ensure objectivity of the assigned ratings, their quality is proved by the long track record.

### **3.7.6 Impact of regulation**

The development of IRB systems will certainly not decrease the importance of external ratings and rating agencies. The latter will continue to play an

important role, since they can act as a benchmarking partner in order to gauge the quality of the internal ratings. Furthermore, external credit ratings can also be used to rate debtors in portfolios where not enough data (e.g., low default portfolios) or modelling experience is available.

Bank regulation resulted in an increasing use of external ratings with explicitly selected agencies. The Basel II Capital Accord defines specific criteria for External Credit Assessment Institutions (ECAI) to be eligible for use in capital requirements [63]. The six criteria specified in the Basel II Capital Accord are

**Objectivity:** A rigorous and systematic methodology to assign credit assessments and ongoing review is required. The methodology needs to be validated on historical experience in the various regions, sectors and asset classes where the rating agency is active. A backtest needs to be applied at least on 1 and preferably on 3 years.

**Independence:** The ECAI and its assessments should be independent and not subject to political or economic pressures. Potential conflicts of interest should be avoided.

**International access/transparency:** The assessments should be available to both domestic and foreign institutions. The general methodology should be publicly available.

**Disclosure:** The ECAI should disclose qualitative information on its assessment methodologies (default definition, time horizon, the meaning of each rating) and quantitative information like historical default rates and transition matrices.

**Sufficient resources:** The ECAI should have sufficient and skilled resources to carry out high-quality assessments and maintain ongoing contacts with senior and operational levels of the rated issuers. The rating methodology should use both qualitative and quantitative resources.

**Credibility:** On top of the above 5 criteria, the ECAI's credibility is evidenced by the use of independent parties for its assessment and internal procedures to avoid misuse of confidential information.

An ECAI does not have to be a global player in order to be recognized. It can be recognized for a specific asset class, sector and/or region. National supervisors are responsible for the recognition process and to map the ECAI's risk grades to risk weights in the standardized approach for regulatory capital calculation. The eligibility criteria have the negative impact of introducing entry barriers in the market and reducing competition in the rating business. To the extent possible, such effects are avoided, e.g., by public disclosure of the recognition process by national supervisors.

Before Basel, external ratings were already used by national banking supervisors in various countries. In the US, the Securities and Exchange Commission (SEC) permits the use of ratings from Nationally Recognized Statistical Organizations (NRSRO) for certain regulatory purposes. In 1975, the main purpose was net capital requirements: “safe securities” were defined as securities with sufficiently high ratings in which banks’ capital was allowed to be invested. It was realized that it also became necessary to specify which ratings were recognized in a rating-based prudential regulation. The eligibility criteria of the Basel II framework are largely based upon the SEC criteria (national recognition, adequate staffing, systematic rating procedures, contacts with the management of the issuers and internal procedures<sup>23</sup>). The first three rating agencies that were recognized in 1975 were Moody’s, S&P and Fitch. At the moment of writing (2007) the Canadian agency Dominion Bond Rating Service and insurance specialist A.M. Best have also been recognized.

Regulation defines entry barriers on the market and changes the perspective of the original core mission of the agencies, i.e. providing investors and private savers with credit information. The changes in bank regulation introduces, wanted or not, important changes in the responsibilities of the agencies, making their revenue stream more dependent on regulatory rules and certifications.

### **3.8 Rating system at banks**

Being stimulated by the Basel II Capital Accord, financial institutions adopting the internal ratings-based approach (IRBA), have started developing more and more their own internal ratings [63]. These ratings then measure the credit risk of obligors taking into account the portfolio specifics of the financial institution.

#### **3.8.1 Bank rating systems and processes**

Nowadays, IRBA systems are being developed, e.g., for retail, firms, banks, municipal, sovereign and insurance counterparts. The extent to which the bank builds internal rating systems depends on its portfolio composition.

<sup>23</sup> For more details, see the proposed regulation: Securities and Exchange Commission, Release No. 34-39457; File No. S7-33097, Dec. 17, 1997.

Banks' internal rating systems have a much broader range and are less coherent than the ratings of the major external agencies. Before the Basel II Capital Accord, banks used internal ratings as a key summary measure for credit risk measurement, management and decision making. Internal rating systems are therefore tailored to the banks individual needs, risk management practices and internal operational processes, which made them less comparable in terms of definition and architecture.

The construction of internal rating scales is tailored to have a cost-efficient monitoring system. For small exposures, automated systems are used because expert analysis costs too much and impacts profitability. For larger exposures, banks rely more on expert judgment. In contrast to rating agencies, banks do not ask a fee for the rating analysis when (potential) customers apply for a loan.

A large survey of US banks gives a good overview of rating systems [479]. When defining an internal rating system, the bank needs to define the risk measure, the rating philosophy and the architecture. These choices depend, a.o., upon the borrower types. The rating horizon varies from one year till the maturity of the loan, moving from behavioral scoring to application scoring. The design may take into account the US regulatory problem asset<sup>24</sup> definition. When internal rating systems have aligned their non-pass grades to these definitions, a potentially difficult mapping problem is avoided. Banks also define watch grades for difficult credits that do not fall into the 4 regulatory problem asset grades.

### **3.8.2 One- and two-dimensional rating scales**

The 1998 study reveals that about 60% of the interviewed banks had a one-dimensional rating system applied to assess the default risk or expected loss of facilities/issues [479]. The remaining 40% have two-dimensional

<sup>24</sup> The 4 problem categories defined by the US federal banking regulators are "Special Mention", "Substandard", "Doubtful" and "Loss". The category "Other Assets Especially Mentioned" (OAEM) indicates that there are potential weaknesses that deserve close attention and may result in further deterioration of the repayment ability if the situation is not corrected. The category "Substandard" indicates inadequate current worth or payment ability. There is a distinct loss probability that justifies the recommended specific reserve of 15%. The category "Doubtful" indicates the weaknesses of substandard and includes highly questionable collection and liquidation in full. The recommended specific reserve for this category is 50%. The category "Loss" is used for uncollectible assets or assets with an LGD value near 100%. A specific reserve of 100% is recommended. All other assets that do not fall into these problem categories are termed "Pass grades".

**Table 3.9** Example of a two-dimensional rating scale with probability of default (PD) and expected loss (EL) dimensions. For each scale, the calibration is made for each label (e.g., from Fig. 3.2). The intervals define the mapping from a local PD and EL to the masterscale. Consider a transaction where the issue has a PD of 1% and an LGD of 45% (both from a local rating scale). The expected loss is 0.45%. On the masterscale, this issuer rating is A, the issue expected loss rating is EL8.

PD			EL		
Label	Midpoint	Interval	Label	Midpoint	Interval
AAA	0.005%	[0%; 0.003%[	EL1	0.001%	[0%; 0.002%[
AA	0.010%	[0.003%; 0.014%[	EL2	0.005%	[0.002%; 0.007%[
A+	0.020%	[0.014%; 0.028%[	EL3	0.010%	[0.007%; 0.014%[
A	0.040%	[0.028%; 0.049%[	EL4	0.020%	[0.014%; 0.030%[
A-	0.060%	[0.049%; 0.081%[	EL5	0.050%	[0.030%; 0.070%[
BBB+	0.110%	[0.081%; 0.148%[	EL6	0.100%	[0.070%; 0.140%[
BBB	0.200%	[0.148%; 0.268%[	EL7	0.190%	[0.140%; 0.270%[
BBB-	0.360%	[0.268%; 0.476%[	EL8	0.380%	[0.270%; 0.540%[
BB+	0.630%	[0.476%; 0.844%[	EL9	0.770%	[0.540%; 1.090%[
BB	1.130%	[0.844%; 1.503%[	EL10	1.540%	[1.090%; 2.170%[
BB-	2.000%	[1.503%; 2.665%[	EL11	3.070%	[2.170%; 4.340%[
B+	3.550%	[2.665%; 4.733%[	EL12	6.140%	[4.340%; 7.300%[
B	6.310%	[4.733%; 8.410%[	EL13	8.690%	[7.300%; 10.330%[
B-	11.210%	[8.410%; 14.68%[	EL14	12.290%	[10.330%; 14.620%[
CCC	19.220%	[14.68%; 25.17%[	EL15	17.380%	[14.620%; 20.670%[
CC	32.950%	[25.17%; 43.15%[	EL16	24.580%	[20.670%; 27.590%[
C	56.500%	[43.16%; 100.00%[	EL17	30.970%	[27.590%; 34.760%[
D1	100.000%		EL18	39.020%	[34.760%; 43.790%[
D2	100.000%		EL19	49.150%	[43.790%; 55.170%[
			EL20	61.930%	[55.170%; 69.510%[
			EL21	78.020%	[69.510%; 87.580%[
			EL22	98.300%	[87.580%; 100.000%[

rating scales, where the first scale reflects the issuer's PD risk and where the second scale measures the EL of the individual issues as illustrated in Table 3.9. Both scales have a similar number of rating grades. The EL of a facility is obtained by multiplying the PD with the LGD of the issue.

The Basel II Capital Accord requires that the risk assessment in banks that apply the advanced<sup>25</sup> internal-rating based approach (IRBA) has 2 dimensions: default risk (PD) and loss risk (LGD). A minimum number of grades for the PD scale is required, but not for the LGD scale.

<sup>25</sup> The different approaches possible in the Basel II Capital Accord are reviewed in Chapter 6.



### 3.8.3 Number of grades

The number of grades in the internal rating scales varies considerably across banks. The risk levels of these internal rating grades are far from consistent. The medium number of pass grades is 5–6, including a watch<sup>26</sup> grade. The number of pass grades indicates a high dispersion and varies from 2 to the low twenties. The level or position of the internal ratings on the scale depends on the bank's overall risk profile. A low-risk bank will have most ratings corresponding to investment grade ratings of Table 3.1. A high-risk bank will have more speculative grade ratings where it can be more important to have more differentiation. A median middle market bank in [479] has about 3 investment grades and 3 speculative pass grades. The internal rating scales also include 3 to 4 regulatory asset problem grades. Apart from the number of rating scales, the effective use of differentiation is also important. It is not very useful to have many grades when most exposure is concentrated in one or two grades. The study revealed that the concentration for most banks was still very high (36% of the large banks had more than 50% of the exposures in a single risk grade). Banks typically introduce more rating scales to increase risk differentiation and reduce concentration in key asset classes. A preferred way is by splitting up rating grades using rating modifiers like the agencies. The number of rating grades used by banks tends to increase.

For Basel II, a bank must have a minimum of seven borrower grades for non-defaulted borrowers and one for those that have defaulted [63]. Many banks apply two grades for defaulted borrowers: “D1” indicating unlikely to pay and “D2” indicating the more severe default cases.

### 3.8.4 Rating philosophy

Most banks apply a methodology that is in between a pure point-in-time (PIT) and through-the-cycle (TTC) rating methodology. Ideally, the rating philosophy corresponds with the bank's investment strategy: banks with short-term investment strategies, e.g., in emerging countries, apply a PIT philosophy, banks with long-term investment strategies apply a TTC methodology. In practice, most banks in developed countries also tend to apply a rating system that implicitly tends to be closer to a PIT scheme, e.g., because the financial variables used in the rating analysis depend on the macroeconomic cycle.

<sup>26</sup> The watch grade terminology should not be confused with the watchlist terminology of external rating grades.

Small data samples and limited data history makes full internal calibration a difficult task. Benchmarking exercises are done with agencies' statistics that are available for long time horizons. The benchmarking of internal with external ratings is not straightforward and is easily subject to comparison mismatches and rating biases. The mapping of internal ratings to external ratings is difficult when the number of risk classes is different: some risk classes will be more granular than those of the rating agency and vice versa. The mapping also depends on the default definition, the actual PD level chosen, the level of conservativeness, the prediction horizon (1-year PD or a multiple-year cumulative PD) and the time period on which the comparison is made. The comparison of TTC ratings is rather easy, a mapping from a PIT system to a TTC system can be split up between recession and expansion periods. Rating comparisons are useful and remain extremely important for low default portfolios, but it is important to consider the limitations of "exact" comparisons.

### 3.8.5 Masterscale

The merger of different banks and the wide variety of asset classes in universal banks result in the existence of multiple local rating subscales that are specific for a region and/or asset class. Different business units within a financial institution may use different rating definitions and subscales. These different rating scales need to be compared internally to a unique representation of risk. For default risk, the unique representation is done via the PD masterscale. A masterscale is then typically used for aligning these various subscales on a common risk scale, thereby providing a lingua franca for talking about risk across the entire financial institution [34]. The mapping to the masterscale suffers from the same difficulties as the mapping to external ratings. Some organizations choose to use the masterscale representation only for reporting purposes; for actual provisioning, capital calculations, etc. the subscales are used. Masterscales can also be defined for the other risk components, but the use of a two-dimensional scale with the second scale reflecting the expected loss is the most common. For investment decisions, risk-return measures like risk-adjusted return on capital (RAROC) are used.

Table 3.9 illustrates a two-dimensional rating scale with a PD and EL dimension. For the PD ratings, the rating labels AAA to C are chosen. The PD levels have been calibrated based upon Fig. 3.2b. The upper and lower parts have been extrapolated. For the expected loss rating scale, more labels are defined to allow for very small values that capture combinations of low

## 162 Credit ratings

PD and LGD. The labels are named different from the PD scale to avoid confusion. The third column of each scale reports the rating buckets<sup>27</sup> that define the mapping process from a local scale to the masterscale as illustrated in the table.

### 3.8.6 Regulation

The Basel II Capital Accord explicitly promotes the use of internal ratings for risk management and capital requirements. It defines minimum requirements for internal rating systems. Bank's internal rating systems used for regulatory capital purpose need to have two<sup>28</sup> dimensions. The borrower dimension reflects the default risk. The facility dimension reflects default and loss risk combined in the expected loss or only loss risk when the bank estimates the loss internally.

The number of risk classes in each scale has to be such that a meaningful distribution across the different grades is obtained, avoiding excessive concentrations. The minimum number of PD borrower grades is seven, where the grades should be such that the PD in a grade is sufficiently homogeneous. At least one grade should be used for the defaulted borrowers, although many banks use both an “unlikely to pay” and “default” grade. The prediction horizon for PD is one year, though ratings may be assigned on a longer time horizon. The use of TTC ratings is clearly preferred that assess the risk during adverse circumstances.

No minimum number of risk grades is required for LGD scales, but also the scale has to be meaningful and avoid large variations of LGD values in one singular scale. LGD values need to take into account economic downturn circumstances. The purpose of the accord is to improve risk management practices in banks towards a more unified use of ratings and towards comparable default and loss statistics. More details on regulatory requirements can be found in Chapter 6.

## 3.9 Application and use of ratings

Credit ratings play a crucial role in many contexts of today's international financial environment. They serve as a key summary of the credit risks

<sup>27</sup> Note that the bucket limits are defined here by (exponential) interpolation of the calibrated midpoint values. It is worth mentioning that an alternative approach is to define the rating buckets symmetric around the midpoints.

<sup>28</sup> For retail exposures, borrower and transaction risk can be combined into one dimension.

of counterparts and transactions. Ratings are a standard and well understood way of communication in banks and in the investors community. Applications of ratings include:

**Providing information:** Ratings are the key summary of risk for investors and private savers. Ratings provide information on the credit quality of the debtor and/or debt instruments and consequently reduce the information asymmetry between lenders and borrowers. Hereby ratings improve the transparency of the credit markets that in turn will improve credit access for lenders and yields for investors.

Institutional investors prefer rated above non-rated debt. Where possible, it is preferred to have ratings from up to all three major rating agencies. For large issuers, the credit rating provides an independent assessment of their own creditworthiness. Issuers request external ratings in order to make an important issuance successful. Otherwise, the (institutional) investors may find the interest rate offered too low or simply decide not to subscribe. Ratings provide credit risk information to investors that do not have the time or resources to make a risk assessment themselves.

**Credit approval:** Ratings may play a crucial role in the credit approval process of a financial institution. Whereas traditionally credit granting only focused on default risk, one may now use both default and recovery ratings in combination when deciding upon the credit. This is illustrated in Table 3.10, where both a default and recovery rating are used to calculate expected loss, which is subsequently limited in order to make a credit decision. In the example of Table 3.10 the threshold is assumed to be 2%. The rating certifies the eligibility of a debt issue or loan for investment.

**Portfolio risk analysis:** When ratings are available for all loans in the portfolio, it allows investors and banks to calculate the risk on their portfolio. The average expected losses are obtained by averaging the risk measures. Loan-loss provisioning and reserves provide a cushion against expected

**Table 3.10** Credit approval based on expected loss, with a threshold of 2.00%. Bold numbers denote the reject region.

		Recovery rating		
		RR1	RR2	RR3
Default rating	A	0.05%	0.06%	1.25%
	B	0.10%	0.12%	<b>2.50%</b>
	C	0.20	0.25%	<b>5.00%</b>
	D	1.80%	<b>10.00%</b>	<b>25.00%</b>

loss. Credit ratings are valuable inputs in order to calculate the latter. In more advanced applications, one uses advanced statistics, like migration probabilities and bond prices, to calculate the portfolio loss distribution.

**Regulation:** Ratings are becoming more and more important from a legal perspective, since supervisory authorities are making regulatory requirements contingent on ratings. An example of this is the Basel II accord, in which credit risk has to be modelled by using external or internal credit ratings. Regulators may also limit or prohibit financial institutions from doing excessive speculative investments, based on the credit ratings.

Apart from bank regulation, ratings are also applicable in other domains like reduced prospectus length for the issuing of well-rated bonds. Certain funds are only allowed to invest in the highest rated bonds. Ratings are also used by insurance regulators to ascertain the strength of reserves of insurance companies. As such, the ratings certify the eligibility of the debt or loans for these various practices.

**Regulatory capital and economic capital calculation:** Both default and recovery ratings are crucial inputs for regulatory and economic capital calculations. When adopting the advanced internal ratings-based approach for Basel II (cf. Chapter 6), one needs estimates for PD and LGD. These estimates are typically calibrated based on the default and recovery ratings. Note, however, that the calibration may differ depending on whether one calculates regulatory capital or economic capital. For example, in the context of recovery ratings, Basel II requires banks to assume economic downturn conditions, which may not be necessary when calculating economic capital.

**Pricing:** For firms, ratings determine bond market prices and yields. Lower ratings will require higher yields and vice versa [13, 286]. In a retail context, risk-based pricing, also referred to as risk-adjusted pricing, sets the credit characteristics, based on the perceived risk. In other words, using default and recovery ratings, one may set the credit limit, interest rate, and/or ask for more collateral.

**Performance measurement:** Risk-adjusted performance measures (e.g., RAROC) measure the return on capital in order to see whether it is being optimally used and allocated. Generally speaking, these measures divide the risk-adjusted income by the capital at risk (regulatory or economic), for which ratings again play a crucial role.

**Debt structuring:** Rating agencies and investment banks also provide rating advisory services that help companies to structure their debt according to the targeted risk profile and interest expenses. A well-rated large firm

may decide to invest in riskier projects by emitting debt via a separate legal entity called special purpose vehicle (SPV), on which one pays high interest rates on smaller amounts, but one keeps paying a low interest rate on the debt of the large company. Vice versa, a lower-rated bank may find it difficult to finance well-rated counterparts, but can create a very low risk SPV that emits debt issues covered by the loans to the well-rated counterparts.

**Securitization:** Ratings play an important role in analyzing the credit risk of all kinds of credit securitization constructs, e.g., asset-backed securities and collateralized debt obligations. Ratings provide a well-understood summary measure of the risk of complex transactions. As such, they are also helpful in pricing, valuing, and trading the securities and also provide useful input for hedging practices.

**Risk reporting:** Ratings also provide a coherent framework for public disclosure of the risk management strategy so as to inform potential future investors.

The use of internal ratings has increased with the Basel II Capital Accord. External ratings will continue to remain important for banks as well for pricing as for double-checking and benchmarking.

### 3.10 Limitations

Credit ratings play a key role in today's financial markets and banks. Both external and internal ratings have become very important. Nevertheless, ratings remain assessments of risk, not crystal balls of the future outcome.

The accuracy of the ratings depends a lot on the quality and relevance of the past experience, the quality of the model, the developers and the rating analysts. Wrong ratings can occur via various sources: the use of non-representative data, a poor model or wrong human expert judgment. All these errors contribute to so-called model risk. A bank needs to accept that internal ratings can be subject to wrong assumptions, a risk that needs to be monitored and managed as well, e.g., by an independent internal validation of internal rating systems and internal risk control.

External rating agencies have shown a good track record on the quality of the information they provide. It forms the basis of their reputation, but nevertheless, errors in judgment may occur [186, 289]. An additional disadvantage is that risk assessments are not absolute numbers in most cases,

while this matters for banks and investors in an environment that becomes increasingly quantitative. The observed loss statistics are volatile (see, e.g., Fig. 3.1a) and have been reported to drift [101].

There have been widespread questions as to why rating agencies reacted slowly in adjusting their ratings to changes in credit quality [17, 35, 162, 185, 323]. The main reason for this persistency is believed to be the through-the-cycle methodology that is used by rating agencies: to avoid ratings fluctuating in reaction to market cycle – and thus achieving a long investment horizon – ratings are changed only when the changes are likely to be permanent [17]. However, sometimes up-to-date information on the counterparty risk can be necessary, as all parties would like to be informed of possible default risk as soon as possible. Market participants themselves evaluate the credit risk of their counterparts. Market prices of financial instruments like bonds and CDS reflect their opinion of the credit risk. Several studies report that price changes lead rating changes, especially when it concerns downgrades [102, 270, 312]. These effects are exploited in market-implied ratings [92, 100, 336, 408]. Despite these negative comments, it is worth recalling that ratings perform overall quite well and that the accuracy of external ratings is regularly reported by the rating agencies [234, 375, 500]. In [101], it is illustrated that default ratings obtained from rating agencies correlate reasonably well with short-term and long-term default rates.

The rating market is dominated by US-based rating agencies, as such there are perceptions of a country bias by issuers outside the US and the coverage in other countries is less complete than in the US. Although conflicts of interest seem not to be exploited significantly, it remains an attention point [200].

The success of external ratings also has negative consequences. Some automated decisions are taken when ratings decrease below certain limits, e.g., the lowest investment grade rating BBB–. Covenants are negotiated that require companies to repay their debt when the rating is downgraded below investment grade. As such, a rating downgrade may start a death spiral where the company is forced to repay the outstanding debt and finds it difficult to refinance because of its lower rating.

Various ratings exist nowadays, with different meanings and different (default) definitions. Sometimes default and expected loss measures are represented on the same scale, making it difficult for investors to distinguish the correct interpretation. The existence of various ratings makes comparability less straightforward.

External ratings are not only costly for issuers. For investors, the automated access to information and summary reports from the agencies is not free. Note that internal ratings systems cost money in terms of data collection, development, IT implementation, use, maintenance and the cost of expert personnel.



# 4. Risk modelling and measurement

---

## 4.1 Introduction

Scoring systems rank observations from low to high scores. Low scores typically indicate less interesting, e.g., more risky, counterparts, while a good score typically indicates good credit quality. Scorecards are not only used in the case of credit risk and/or banking applications. Scoring systems are also used in many other applications like stock selection, macroeconomics, insurance, fraud detection, marketing, engineering, chemistry, pharmacy and medical diagnosis. As the continuous scores typically contain too much information in practice, one typically defines buckets of scores that have more or less homogeneous properties.

In the banking industry, the homogeneous buckets correspond to credit ratings discussed in Chapter 3. Generally, an internal rating system first applies a scoring function to assign a score to the counterparts, while in a second step, that score is translated into a rating that reflects, e.g., the default risk. Important qualities of a rating system are the discriminative<sup>29</sup> power and the accuracy of the model calibration. The discriminative power of the score function is its ability to separate “good” from “bad” counterparts. The accuracy of the model calibration reflects how well the actual risk corresponds to the risk defined in the homogeneous buckets. A well-calibrated model will allow accurate prediction of the average amount of future losses.

While in the early stages, credit scoring and rating models were primarily applied to estimate the default risk of a portfolio, more recently scoring functions and rating models have also been designed to model recovery and/or expected loss risk. Such internal rating models are extremely important,

<sup>29</sup> The term discrimination is most applicable for classification problems (PD), while precision is used for regression problems (LGD, CCF).

because the model influences on a microlevel the lending policy of the bank on individual transactions. The rating determines not only the risk, but also provides a reference for the pricing, provisions, regulatory and economic capital calculation. Depending upon the management's risk appetite, credit decisions are taken by considering marketing, strategy, risk and return. On a macrolevel perspective, accurate internal rating systems give good information regarding the expected losses of the portfolio and allow for correct pricing. Incorrectly calibrated models will either over- or underestimate the risk, where especially the latter may have far-reaching consequences for the bank. The discriminative power of the PD scoring function may influence the profitability of the bank. Banks with highly discriminant and accurate rating systems are better able to avoid losses as bad counterparts are better or earlier rejected. At the same time, the number of unnecessarily rejected counterparts is reduced. Less discriminant rating systems yield, *ceteris paribus*, higher loss rates and reduced profitability.

This chapter is concerned with risk quantification. The risk measurement concerns the actual measurement of the risk in a risk grade or on a total portfolio. The measurement quantifies the actual default risk (probability of default), the loss risk (loss given default) and the exposure risk (exposure at default). A simple way of risk measurement is to learn from past data when available. Risk modelling deals with the understanding and prediction of risk levels. Risk drivers that differentiate risk among different issuers or issues are identified. Homogeneous pools or segments are defined and the risk level is calibrated, e.g., by measuring the risk level on the recent history. Because of the importance of risk measurement and modelling, there exists a wide variety of techniques that are explained in detail in Book II.

This chapter highlights the conceptual aspects of a rating system without focusing on mathematical and technical aspects. An overview is provided of the different aspects of risk measurement and modelling: data, modelling techniques and implementation for use. All aspects of the development and implementation of a new model are discussed. The system life cycle is explained in section 4.2. section 4.3 provides a high-level overview on credit scoring models. Such models rely on data, for risk measurement, model use and for model development. The data issues are discussed in section 4.4. A bird's eye view on the model development process of internal rating systems is provided in section 4.5. All the different steps of the development are discussed. Implementation aspects are discussed in section 4.6. Credit scoring models are not static applications, but dynamic instruments that are used in continuously evolving and changing environments. section 4.7 explains

that models need to be maintained and updated regularly. Given the importance of the model results for the different aspects of the banks, models are subject to strong internal and external control before being put into operation and during operation. section 4.8 explains the different, but also partially overlapping aspects of model validation, quality control and backtesting.

## 4.2 System life cycle

The rating system life cycle consists of the different phases depicted in Fig. 4.1. The system life cycle starts with the inception of the internal rating system and its definition. The most interesting, but also difficult part are the early phases of the development. It is very difficult to estimate a priori the amount of time and energy the data collection and model development will take. After a successful development, the model is implemented in the organization. The model use is an ongoing process. During model use, the performance of the model is monitored and evaluated on a regular basis.

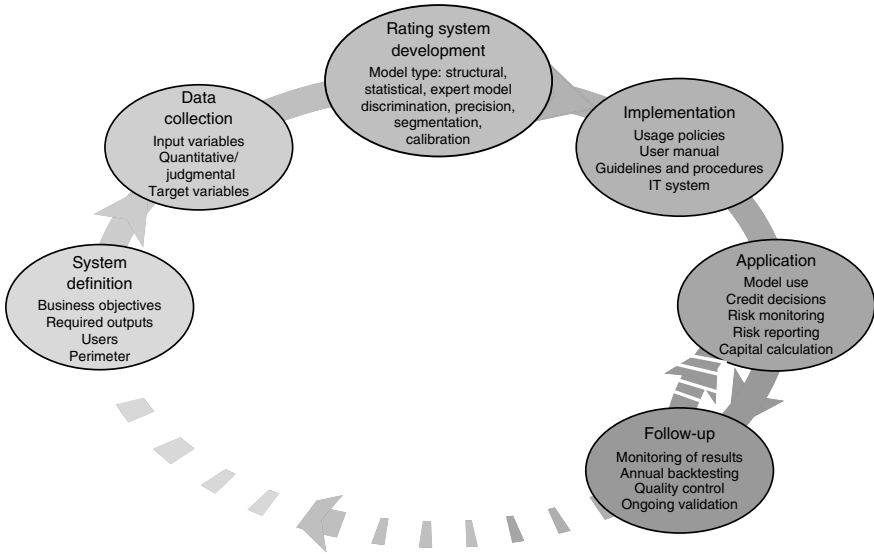

**Fig. 4.1** Different phases in the model life cycle. The birth of the internal rating system starts with its definition. Data is collected in the second phase. This data is used to develop the internal rating system. After a successful development, the model is implemented in the organization. Then the model’s real life starts: it is applied in the bank and its performance is monitored. This follow-up may involve any of the previous phases when a model update or refinement becomes necessary.

When necessary, the model is refined, updated or changed, which requires going back to a previous phase. The main life-cycle phases are observed in any data-analysis project. Industry standards for data warehousing, reporting and project management are being developed, a.o., CRISP-DM [443].

The different phases in the model life cycle are the following:

**System definition:** The development of a model starts with the definition of the model purposes and goals. These specifications are determined by the business needs, the management's requirements and the bank's strategy. External factors also determine the model purposes, e.g., the recently put forward Basel II Capital Accord has triggered the design of many internal rating systems for banks that opt for the internal ratings-based approach. The perimeter to which the model will be applied is specified. Potentially also subportfolios to which a variant of the main model will be used are also indicated.

The model purposes include the model use, who is going to use and run the model, where will the model be used (credit decision tool or aid, risk monitoring, early warning, provisioning, capital calculation, ...). The responsible persons for model development, implementation and maintenance are appointed.

The main characteristics of the model are defined in this step. The most important features and feasibility aspects of the next phases in the model design are evaluated. Minimum performances are required.

For models on new sectors or for models that are constructed for the first time in the organization, a pre-study to gather all the business knowledge is applied. This pre-study provides information on the macroeconomic environment, risk drivers, support logic, ... It helps to decide upon the model formulation.

**Data definition and collection:** For the defined perimeter, one identifies and selects potential data sources to construct the model. The data sources are defined based upon their relevance, coverage and representativeness for the perimeter, the quality and reliability of the data content and their cost. It can be cheaper to purchase external data instead of collecting internal data, on condition that the external data is representative of the internal portfolio.

For empirical models, one needs to determine two types of variables: explanatory, input variables and explained, target variables. Examples of explanatory variables are return on equity, debt level, ... Large sets of candidate explanatory variables need to be defined by financial analysts

in co-operation with statisticians. Data need to be gathered internally or externally. The target variable represents default, loss or exposure risk. Loss and exposure risks are continuous variables (LGD, CCF). The exact meaning of these variables is defined in the organization. Basel II has defined minimum requirements for these definitions. The data gathering and calculation of these values internally can be a complex task. For default data, one uses binary labels that indicate whether the counterparty defaulted or not (using some definition of default). One can also use external ratings, like long-term default ratings that range from AAA to CCC. One needs to decide who will collect the data for model development and how the data will be gathered in the operational phase.

**Development of the internal rating system:** The development of the internal rating system is a complex and technical task. Many assumptions are explicitly and implicitly made, it requires a big effort and sufficient experience to make adequate decisions. The development starts with important questions on the type of model that will be used: complete new model development, partial reuse of an existing model with some adaptations, full reuse of an existing model, purchase of an external model. Models can be theoretical or structural models; or empirical models that are based upon past experience. Some of these model choices are already determined at the model definition phase as they also impact data definition and collection. The choice of the model type will also be constrained by data availability.

An important aspect in the modelling is the definition of the model architecture and the importance of the different subcomponents of the model, like, e.g., the financial strength, support, expert override in Fig. 3.3. One needs to determine the importance of the building blocks for the different asset classes. In some models, like retail, the override is limited to borderline cases (Fig. 2.2). In other, e.g., heterogeneous sectors, expert judgement is likely to be more important. When no data at all is available, one can start with an expert-based scorecard of which the data are stored for future update. Another option in the case of low data availability are the use of external models or structural models. For empirical models, the statistical approach and assumptions need to be well motivated. An important aspect for empirical models is the choice of the relevant explanatory variables and the trade-off between model complexity and accuracy.

The development does need to take into account statistical, financial and regulatory constraints and practices. The impact of the resulting model on

the organization, its functioning and way of working need to be taken into account in the decision process as well. The model choices are preferably made by financial experts and statistical experts together with the management. The model development is documented to indicate and motivate the many modelling choices made.

**Implementation:** The developed model is implemented in the organization. The specifications for an IT implementation are written: input data sources and variable calculations, model calculation steps, model outputs. The data flows from the organization to the internal rating system, inside the internal rating system and from the internal rating system to the bank. It is indicated how human interaction and overrides are integrated in the model and how internal ratings are approved by the chief financial analysts. Where possible, one can use a generic IT system to implement multiple similar rating systems to reduce costs. The IT system has to provide a good overview of the model functioning and its intermediate steps to the end-user. Input, output data as well as intermediate results are stored for model monitoring and follow-up. Together with the implementation, the user manual that explains the model and how to use the implementation is written.

The model and its use are integrated in the organization. Internal procedures and guidelines are adjusted to the new risk measures. The decision procedures and delegation rules are updated. Responsibilities for model use, follow-up and possible updates for future model evolutions are defined.

**Application:** The implemented model is applied in the organization. It runs either fully automatically, semiautomatically or manually. Manual intervention is required for judgmental input variables and the override procedure. The automated model is applied in batch mode or sequentially when new data becomes available or a new analysis is required. In systems with human expert judgment, rating updates are calculated automatically when new quantitative information becomes available. Financial analysts can pay special attention to counterparts with important rating changes and advance them in the rerating scheme.

The application phase is the lengthiest period of the model life-cycle. The model is used to measure the risk of new customers and existing positions. The model outcomes are used in credit decisions, pricing, reporting and capital calculations.

**Follow-up:** During its use, the model performance (accuracy, discrimination, stability) is evaluated on an ongoing basis to reduce model risk.

The ongoing model validation consists of quality control and backtesting. The quality control verifies correct model use and outcomes. The backtest exercise is a statistical analysis to compare predicted results with the actual outcome and to detect possible changes in the model behavior. Backtesting is typically done once a year, quality control is an ongoing task.

Based upon the results of the model follow-up, one decides to continue to apply the model or update the model. Changes in the environment and decreasing model performance demand model maintenance. Major maintenance sessions may involve important data collection, development and implementation efforts.

Independent internal and external validation reviews the whole process. Validation at origination looks at the model development phase: data quality, sound model design and correct implementation and use. Ongoing validation is the model follow-up phase that consists of quality control and backtesting.

### 4.3 Overview of rating systems and models

Important choices in the development of the rating system are the choices of the overall architecture and of the modelling technique. Jankowitsch *et al.* [281] showed that improving the accuracy of a rating system can have significant effects on portfolio returns. The choice of the most appropriate rating architecture and technique depends upon the availability of adequate model formulations, data availability and implementation constraints. Not all models in the overview are directly applicable for all scoring and rating problems. The knowledge of alternative formulations yields, nevertheless, interesting information to enrich models.

In structural and reduced-form models the risk parameters are determined with a model that is derived from financial theory. Empirical models estimate and explain the risk parameters by learning from past observations. Expert models and expert analysis reflect human expert knowledge. A conceptual overview of model approaches is depicted in Fig. 4.2, where prominent techniques are classified according to their most important feature. To develop a practical model, one may combine different types of techniques.

#### 4.3.1 Financial models

Financial models provide a theoretical framework to assess the risk of the counterpart. Their theoretical foundation makes structural models intuitively

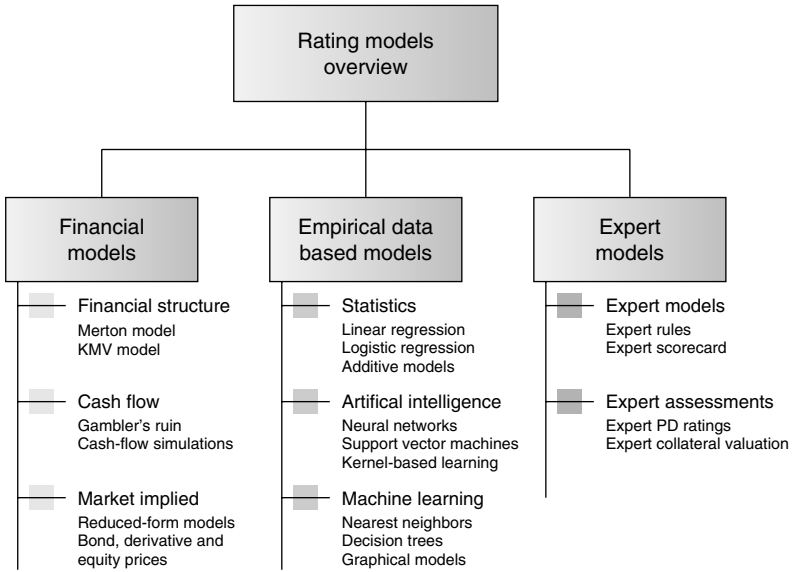

**Fig. 4.2** Overview of modelling techniques: structural and reduced form models are based on financial theory, focusing on the financial structure, cash-flow analysis or market prices. Empirical models infer the risk drivers from historical data using a large variety of techniques originating from the fields of (applied) statistics, artificial intelligence and machine learning. Expert models use either formal expert models developed by experienced risk analysts or may involve case by case expert rating assignment. In practical cases, it occurs that different techniques are combined. For illustrative purposes, some reference techniques are listed according to their most important feature.

appealing: their functioning can be explained and understood even in the absence of data. While other models rely only on the observed data and statistical analysis, structural models can be defended based on the theoretical framework. Of course, one always needs to assess its functioning in practice to see whether all assumptions in the model derivation are also observed on real data.

The two important structural models for assessing credit risk are Merton’s model [355] and Gambler’s ruin [513]. In both models, a volatility or uncertainty measure is compared to a safety cushion that serves to absorb losses in case of business downturns. In the Merton model, the risk is expressed in terms of the financial structure, in the Gambler’s ruin, a cash-flow analysis is applied. Default occurs when the safety cushion is used up. The default probability is the probability that such an event takes place. Reduced-form models are another type of financial models that assume that the firm’s default



behaviour is driven by a default intensity that is a function of latent state variables [155, 283].

#### 4.3.1.1 Financial structure: Merton model

Merton's asset value model was first suggested in the paper of Merton [355] and the paper of Black and Scholes [80] on option pricing theory. Consider a firm with total asset value  $A \geq 0$  that is financed with equity  $E \geq 0$  and a zero-coupon bond with face value  $F \geq 0$  at maturity  $T$ . At each time  $t$ , the firm value  $A_t$  equals the sum of the  $E_t + D_t$ .

Between time instant 0 and  $T$ , the firm is challenged by many opportunities and threats that may impact the asset value. These uncertainties are described by a stochastic Brownian motion process for the asset value  $A_t$ :

$$dA_t = \mu A_t dt + \sigma_A A_t dz, \quad (4.1)$$

with  $\mu \in \mathbb{R}^+$  the firm's asset value drift,  $\sigma_A$  the asset volatility and  $dz$  a Wiener process  $dz = \sqrt{t}\varepsilon$ , with  $\varepsilon$  standard normally distributed. At the end of the period, the assets have value  $A_T$ :

$$\log A_T = \log A_0 + \left( \mu - \frac{\sigma_A^2}{2} \right) T + \sigma_A \sqrt{T} \varepsilon. \quad (4.2)$$

The stochastic Brownian motion is visualized in Fig. 4.3.

Default occurs in case the asset value is lower than the face value of the debt. In such case, the bondholders have higher priority to recover their investments than the equity holders. They receive the remaining asset value and make a loss  $F - A_T$ , while the equity holders receive nothing. When the firm does not default, the equity holders receive the full upside (adjusted for debt)  $E_T = A_T - F$ , while the bond holders receive the face value  $F$  as specified in the contract. The pay-off for equity and bond holders as a function of the asset value is summarized by the following formulae

$$E_T = \max(0, A_T - F) = |A_T - F|_+$$

$$D_T = \min(F, A_T) = F - \max(0, A_T - F) = F - |A_T - F|_+.$$

The pay-off for equity and bond holders is depicted in Fig. 4.4. The pay-off structure is quite similar to option pay-offs. Firm debt can be seen as risk-free debt and a short put option.

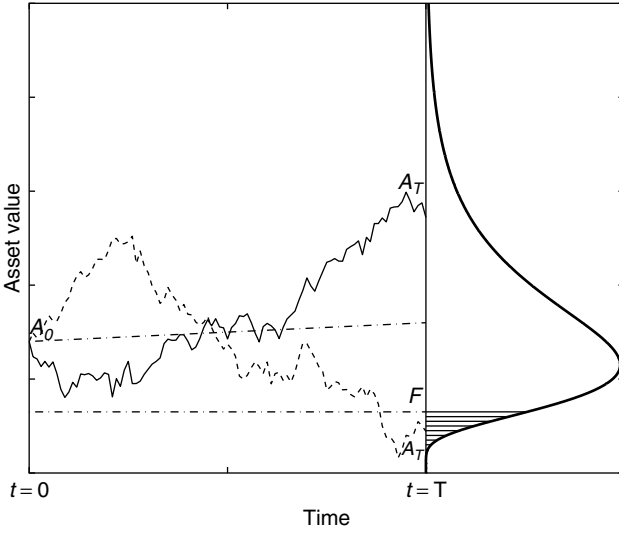

**Fig. 4.3** Illustration of the Merton model. A firm with initial value  $A_0$  will default on a bullet loan with face value  $F$  at maturity date  $T$  when  $A_T \leq F$ . The asset value  $A_T$  follows a stochastic Brownian motion process. The full line presents a positive scenario, the dashed line a default scenario. The default probability is indicated by the shaded surface of the log-normal distribution.

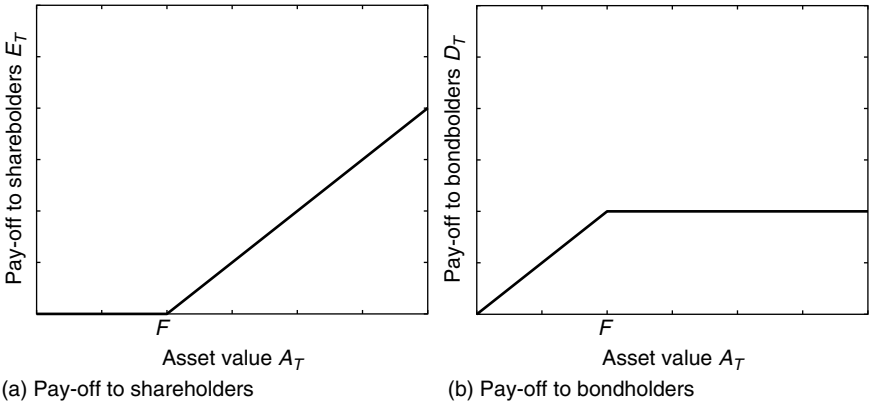

**Fig. 4.4** Pay-off to share- and bondholders as a function of the asset value  $A_T$  at maturity date  $T$ . The sum of both pay-offs equals the asset value  $A_T$ .

The probability of default (PD) at time  $t = 0$  is the probability that the company fails to repay the debt  $F$  at maturity date  $T$

$$PD = p[A_T < F] = \Phi_N(-d_2) = \Phi_N\left(-\frac{\ln(A_0/F)}{\sigma_A\sqrt{T}} + \frac{\sigma_A\sqrt{T}}{2}\right). \quad (4.3)$$

The above expression is easily obtained by comparing eqn (4.2) with the default threshold  $F$  at maturity  $T$ . The value

$$DD = -d_2 = -\frac{\ln(A_0/F)}{\sigma_A\sqrt{T}} + \frac{\sigma_A\sqrt{T}}{2} \quad (4.4)$$

is also known as the distance to default (DD). The expected loss is obtained by multiplying the possible losses  $|F - A_T|_+$  with the probability that they occur for all possible values  $A_T \in [0, F]$ . The expected loss amount at maturity  $T$ :

$$EL = F \left( \Phi_N(-d_2) - \frac{A_0 \exp(rT)}{F} \Phi_N(-d_2 - \sigma_A\sqrt{T}) \right), \quad (4.5)$$

with  $r$  the risk-free interest rate drift. The expected loss amount is also expressed in terms of the EAD, PD and LGD. Using  $EL = F \times LGD \times PD$ , the loss given default (per unit  $F$ ) becomes

$$LGD = 1 - \frac{A_0 \exp(rT)}{F} \frac{\Phi_N(-d_2 - \sigma_A\sqrt{T})}{\Phi_N(-d_2)}. \quad (4.6)$$

The above formulae indicate already that with higher leverage and asset volatility, the default risk increases. The equity serves as a buffer to negative events that reduce the asset value. A side effect is that the LGD decreases as the PD increases, which is not always observed on practical data.

The asset value is not always a directly observed variable, but equity volatility is obtained daily from the stock market and is related to asset volatility. The above formulations make some simple assumptions. The debt structure is very simple with only one issue of zero-coupon debt, default occurs at maturity date  $T$ , the risk-free interest rate  $r$  is constant, . . . There exists a substantial literature of extensions that relax some of these unrealistic assumptions. A well-known commercial application is KMV Credit Monitor, which provides point-in-time credit risk assessments [123, 425]. Given the large database of companies the KMV product covers, the expected default frequency (EDF) is calibrated from the DD based on empirical observations.

#### 4.3.1.2 Cash-flow analysis: gambler's ruin

The gambler's ruin model is a structural model in which equity is considered as a cushion to protect debtors against cash-flow volatility. Negative cash flows drain the equity reserve, while positive cash flows increase the reserves. The technical default point is the point where the equity reserves

are completely exhausted. The name gambler's ruin comes from the similarity to gambling games where one starts with  $E$  euros and bets 1 euro with 50%/50% probability to either receive 0/2 euros. The gambler's "default" occurs then when the initial capital  $E$  is fully consumed. The statistical theory to compute the gambler's ruin probability was well developed and was also applied to solve the default probability problem.

The distance to default in the gambler's ruin model is equal to

$$\text{Distance to default} = \frac{\mathbb{E}(\text{CF}) + E}{\sigma_{\text{CF}}}, \quad (4.7)$$

and depends on the average cash flow ( $\mathbb{E}(\text{CF})$ ), the book value of the firm's equity ( $E$ ) and the cash-flow volatility  $\sigma_{\text{CF}}$ . The average cash flow and cash-flow volatility are estimated by simulation of a set of possible cash-flow evolutions based on a two-state (or more) Markov process with possible cash-flow states  $\text{CF}$  and state transition matrix  $\mathbf{T}$ :

$$\text{CF} = \begin{bmatrix} \text{CF}_1 \\ \text{CF}_2 \end{bmatrix}, \quad \mathbf{T} = \begin{bmatrix} p_{11} & p_{12} \\ p_{21} & p_{22} \end{bmatrix}, \quad (4.8)$$

where  $p_{ij} = p(\text{State } j | \text{State } i)$  denotes the transition probability to move from state  $i$  to  $j$ . The parameters can be obtained from historical data and expert knowledge. Compared to the Merton model, the estimation of the average and standard deviation of the cash flow has to be done on much less data; which makes it much more difficult to apply this model.

Further extensions to the initial formulation by Wilcox include an adjustment to the equity book value for the definition of the cut-off point [433]. The market value of the firm may exceed the book value, which will stimulate equity holders to invest in the firm in the case of insufficient book equity value. The observation is that firms do not default because of negative equity book value, but because people lose faith. Empirical observations support this reasoning: market values are a multiple of book values, while default rates are much lower than the proportion of firms with negative equity.

Cash flow models are also interesting to evaluate the risk of start-ups, young firms and projects, when balance sheet information or a track record is not available. An important advantage of such models is that they can take into account specific features. Also, rating agencies often use cash-flow models to rate counterparts for which individual characteristics are important in the risk analysis or for which the population is too limited to develop statistical models. Simulation models for structured products can be considered as stochastic cash-flow models.

### 4.3.1.3 Market implied: reduced form models

Reduced-form models [155, 283] start from an expression for the default time  $\tau$  or stopping time generated by a Cox process. Such a Cox process is a generalization of a Poisson process with stochastic default intensity  $\lambda(s)$  that describes the likelihood that the number of events  $N(t)$  occurs in the time interval  $[0, t]$ .

The default intensity parameter  $\lambda$  indicates the rate at which events occur. In the case of a constant  $\lambda$ , the probability distribution is given by

$$P(N(t) = k) = \exp(-\lambda t) \frac{(\lambda t)^k}{k!}, \quad k = 0, 1, 2, \dots$$

Default occurs when the event at time  $\tau$  occurs before the maturity date  $T$  and  $N(T) > 0$ . There occurs no default when there occurs no default event, i.e.  $N(t) = 0$  or  $\tau \geq T$ , which has probability

$$P(N(T) = 0) = \exp(-\lambda T),$$

still assuming a constant default intensity  $\lambda$ . In the case of a Cox process, the default intensity  $\lambda_s$  is a stochastic parameter that depends on state variables. The corresponding probability that no default occurs is equal to

$$P(N(T) = 0) = \exp\left(-\int_0^T \lambda_s ds\right).$$

When the LGD is known, the price of the debt instrument becomes

$$\text{price}(\text{debt instrument}) = \text{LGD} + (1 - \text{LGD}) \times P(N(T) = 0),$$

neglecting the correction factor for discounting cash flows. Reduced-form models are often applied for pricing market instruments [431]. Quantity and quality of the data are important to the model's quality.

There has been much discussion in the literature comparing reduced-form models with structural models. From a theoretical perspective, reduced-form processes also allow discontinuous jumps in the firm's value,

$$dA_t = \mu A_t dt + \sigma_A A_t dz + B_t dy, \quad (4.9)$$

where  $B_t$  is a stochastic variable indicating the jump size and  $dy$  is a Poisson process. Structural models (4.1) allow only continuous movements. The jump process and the unknown default time can be interpreted as incomplete knowledge from the model compared to the knowledge the manager

of the firm has. The model has access to the same information as the market has, while structural models assume similar information as the firm's manager [282]. There exist many research articles that compare the empirical performance in terms of default capacity and/or pricing accuracy, see, e.g., [284].

From a broader perspective, these reduced-form models are part of a broader model class that determines risk parameters out of market prices. Such market-implied models have the advantage that market data is often easily available and can be updated frequently, which improves their reactivity. Their output depends, nevertheless, on market risk perception, which may differ from empirically observed risk levels.

### 4.3.2 Empirical statistical models

A disadvantage of structural models is that their theoretical background may not always match completely with empirical observations. When one has sufficient data, one estimates empirical statistical models of which the parameters and also the structure are learned from the data.

Statistical models determine empirically a valid relation between explanatory variables and the explained variable. Explanatory variables are also called input variables, independent variables or risk drivers. Financial ratios are typical explanatory variables. The explained variable is also known as the dependent or target variable. The target variable is typically a risk measure like LGD and CCF. In the case of default risk, it is a binary variable indicating the default status or a default risk measure, like external ratings.

A famous example of an empirical statistical model is the Altman  $z$ -score model (eqn 2.1) for large firms:

$$z = 0.012x_1 + 0.014x_2 + 0.033x_3 + 0.006x_4 + 0.999x_5,$$

where  $x_1, \dots, x_5$  are financial variables [12]. The parameters 0.012, 0.014, 0.033, 0.006 and 0.999 were determined to separate bankrupt from non-bankrupt data on a training set of 68 firms. The  $z$ -score model is an empirical model: although each of the 5 financial variables is financially an intuitive predictor for bankruptcy risk, the linear combination of the variables and its parameters are an empirical approximation to a more complex default risk behavior. Most scoring systems are variants of such empirical models.

An early reference on empirical models is the work of Fitzpatrick [189] in 1932. There, the link was made between financial ratios and default risk. In 1966, Beaver analyzed which individual financial ratios were good

predictors of default [68]. It was found that ratios like cash flow/net worth and debt/net worth exhibited large differences between healthy and distressed firms. Altman applied linear discriminant analysis in 1968 to find an optimal linear combination (eqn 2.1) of 5 ratios [12]. The explanation of external ratings by financial variables was reported by Horrigan in 1966 [261]. The techniques of statistical estimation improved further, a.o., with the application of logistic regression by Ohlson in 1980 [379]. Surveys can be found in [14, 369, 523]. Apart from the evolution of statistical techniques, the data availability increased significantly. While Fitzpatrick [189] used 36 observations, nowadays algorithms use multiple thousand observations and even more in retail environments [31].

The design and estimation of empirical models is part of the domain of applied statistics. The quality of an empirical model is determined by data quality and the quality of the statistical design. Important aspects in the statistical design are the choice of the target variable (e.g., 0/1 default flag on 1, 2 or 3 years; LGD, CCF); the cost function definition and estimation algorithm; the choice of the explanatory variables; the model complexity and the model structure. The evaluation criteria need to be specified. Below, a survey of different model aspects is provided. Details are given in Book II.

#### 4.3.2.1 Model structure

Based on financial ratios, qualitative and judgemental indicators, and possibly other relevant information, the credit scoring model computes a score that is related to a risk measure. There exists a wide variety of model structures.

In linear model structures, the  $z$ -score is a linear combination

$$z = w_1x_1 + \dots + w_nx_n + b \quad (4.10)$$

of the explanatory variables  $x_1, \dots, x_n$ . The explanatory variables are also called independent variables, input variables or model inputs. In many applications, these variables are financial ratios. The linear model structure is visualized in Fig. 4.5a. The model parameters or weights  $w_1, \dots, w_n$  and bias term  $b$  are estimated by optimization of the discrimination behavior or precision. The above model formulation defines a linear score relation. In the Altman  $z$ -score model (eqn 2.1) the linear discriminant analysis optimization of the parameters resulted in  $\hat{w}_1 = 0.012$ ,  $\hat{w}_2 = 0.014$ ,  $\hat{w}_3 = 0.033$ ,  $\hat{w}_4 = 0.006$  and  $\hat{w}_5 = 0.999$  [12]. For the score function application, the bias parameter  $b$  does not need to be reported.

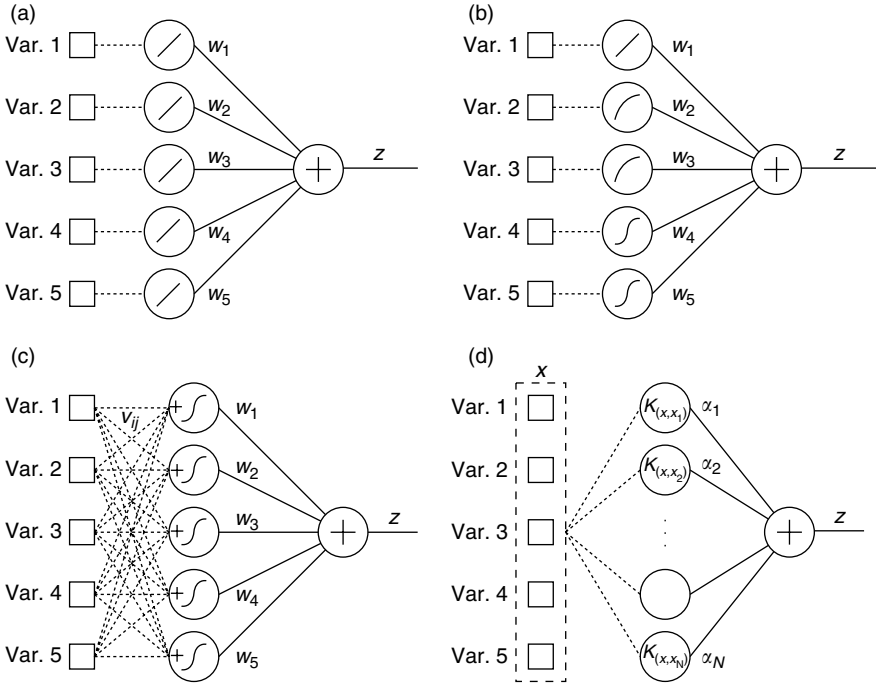

**Fig. 4.5** Model architectures to compute the  $z$ -score from the input variables  $x_1, \dots, x_5$  (var. 1,  $\dots$ , var. 5). The linear (a), intrinsically linear (b) and MLP model (c) are parametric models with increasing complexity and learning capability. The SVM or kernel-based model (d) is a non-parametric model where the learning capacity depends, a.o., on the choice of the kernel function  $K$ .

A more advanced model formulation uses additional parameters that pre-transform (some of) the ratios by a parameterized function  $f(x; \lambda) = f(x; \lambda_1, \dots, \lambda_m)$

$$z = w_1 f_1(x_1; \lambda_1) + \dots + w_n f_n(x_n; \lambda_n) + b, \tag{4.11}$$

as indicated in Fig. 4.5b. Such a model belongs to the class of additive models. These models are also called intrinsically linear models because they are linear after the non-linear transformation of the explanatory variable. Each transformation  $f_i$  transforms in a univariate way the ratio  $x_i$ . The parameters of the transformation are optimized so as to increase the precision or discrimination ability [90, 245]. Two examples of such transformations are logarithmic and related exponential transformations, as depicted in Fig. 4.6. These transformations were used for an internal rating system for bank default risk [488].



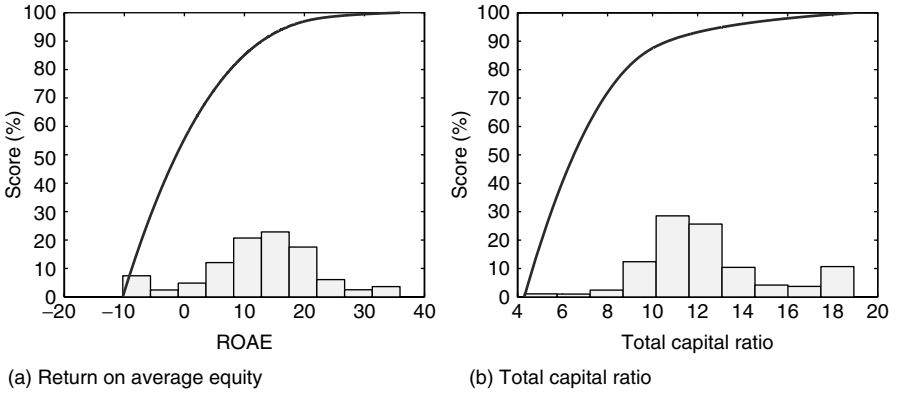

**Fig. 4.6** Visualization of the identified univariate non-linear transformations for the total capital ratio and the return on average equity in a model for rating banks. The Basel Capital Accord requires a minimum total capital ratio of 8%. Values below 8% are increasingly penalized. For values higher than 10%, a saturation effect occurs. The same holds for the ROAE. Values above 10% are not rewarded further. Negative returns, i.e. losses, are increasingly penalized. More details can be found in [488]. The ratio distribution is indicated by the histograms.

More complex models allow for more complex interactions between the variables. Neural networks are a typical example of such parameterized models. A multilayer perceptron (MLP) neural network model with one hidden layer has the following parameterization (Fig. 4.5(c)):

$$z = \sum_{k=1}^{n_h} w_k f_{\text{act}} \left( \sum_{l=1}^n v_{kl} x_l + b_k \right) + b. \tag{4.12}$$

The parameters  $b$ ,  $w_k$ ,  $b_k$  and  $v_{kl}$  are optimized to provide optimal discrimination ability on both current and future data. Typical activation functions  $f_{\text{act}}$  are the hyperbolic tangent function or other S-shaped locally bounded piecewise-continuous functions. The MLP model is very popular because of its universal approximation property that allows any analytical function to be approximated by an MLP with two hidden layers. A disadvantage of the increased learning capacity and modelling flexibility is the model design. The optimization problem is non-convex and thus more complex because the global optimum is typically situated between multiple local minima.

Parametric models allow specification of the model structure, while the unknown parameters are learned from the data. When the LGD and CCF

values are<sup>30</sup> constrained between 0 and 100%, one can use a linear hidden neuron function combined with a sigmoid output neuron that squeezes the network output between 0 and 100%.

The above models specify a parameterized form  $f(x_1, \dots, x_n; w_i, \lambda_j)$  of the discriminant function in which the parameters  $w_i$  ( $i = 1, \dots$ ),  $\lambda_j$  ( $j = 1, \dots$ ) are optimized to discriminate between (future) solvent and non-solvent counterparts. Non-parametric kernel-based learning models do not specify a parameterized form of the discriminant function. Instead, a discriminant function is estimated  $z = f(x_1, \dots, x_n)$  that learns to discriminate between good and bad counterparts subject to a smoothness constraint:

$$\begin{aligned} f_{\text{approx}}(\mathbf{x}) &= \operatorname{argmin}_f \mathcal{J}(f) = \text{Classification cost}(f; \text{data}) \\ &\quad + \zeta \text{Regularization term}(f) \\ &= b + \sum_{i=1}^N \alpha_i K(\mathbf{x}, \mathbf{x}_i) \quad (\mathbf{x} = [x_1, \dots, x_n]^T). \end{aligned} \quad (4.13)$$

The classifier is then  $\operatorname{sign}[b + \sum_{i=1}^N \alpha_i K(\mathbf{x}, \mathbf{x}_i)]$ , where the vector  $\mathbf{x}_i \in \mathbb{R}^n$  consists of the  $n$  ratios of the  $i$ th training data point ( $i = 1, \dots, N$ ). The corresponding model structure is indicated in Fig. 4.5(d). The training set classification cost function is often a cost function used in linear parametric models like least squares or negative log likelihood, while the regularization term involves a derivatives operator that penalizes higher-order derivatives of the function  $f$  and promotes smooth discriminant functions. The derivative operator is related to the kernel function  $K$ . The regularization parameter  $\zeta > 0$  determines the trade-off between the training set cost and the regularization. Support vector machines (SVMs) and related kernel-based learning techniques can be understood as non-parametric learning techniques. Compared to MLPs, the solution follows from a convex optimization problem. The solution is unique and no longer depends on the starting point for the optimization of the model parameters. Apart from computational convenience, this property ensures reproducibility of the model parameter estimates. The main properties of these kernel-based techniques are well understood given the links with regularization networks; reproducing kernel Hilbert spaces; Gaussian processes; convex optimization theory; neural networks and learning theory. SVMs have been reported many times to perform at least equally

<sup>30</sup> Note that the ceiling of 100% may not always be applicable.

well or better than linear techniques and neural networks on many domains [31, 133, 178, 272, 340, 430, 460, 492, 506].

All these theoretical and practical properties mean that SVMs and kernel-based learning techniques are becoming a powerful reference technique. While SVMs and related kernel-based learning techniques focus on the model discrimination ability, other non-parametric techniques are more related to density estimation; like Nadaraya–Watson and nearest neighbors. Semiparametric models combine a parametric and non-parametric part of the score function.

Neural networks and SVMs are often called data mining and machine learning techniques, which is a broad classification of supervised modelling techniques that learn relations from data. Other techniques like Bayesian networks, decision trees and graphical models are counted among the machine learning techniques [154, 245, 361, 410]. An example of a simple graphical model is depicted in Fig. 4.11. Such techniques are extensively discussed in Book II. Non-linear models are more flexible and allow more complex interactions and improved modelling capability, but need appropriate learning techniques<sup>31</sup> to avoid overfitting. The term overfitting indicates that the model performs too well on the training data, but will not generalize well and perform significantly worse on new data. Overfitting occurs typically when there are too many parameters fitted on a small number of training data. Some of the resulting models are also more difficult to interpret.

#### 4.3.2.2 Cost function

The cost function  $\mathcal{J}$  determines the criterion to which the model and its parameters will be optimized on the data. For LGD and CCF values, it is normal to tune the model such that the differences between the (continuous) target variable and the model output are minimized. Such problems are regression problems and are illustrated in Fig. 4.7a. When the linear model (eqn 4.10) produces an LGD estimate, one calculates for each observation the error

$$e_i = \text{LGD}_i - \text{LGD}_{\text{model}}(\mathbf{x}_i | w_1, \dots, w_5, b)$$

on all observations  $i = 1, \dots, N$  in the training data set. The linear model gives the result  $\text{LGD}_{\text{model}}(\mathbf{x}_i | w_1, \dots, w_5, b) = z_i = w_1 x_{1,i} + \dots + w_5 x_{5,i} + b$ .

<sup>31</sup> For example, one can tune the effective number of parameters using Bayesian learning, complexity criteria and statistical learning theory.

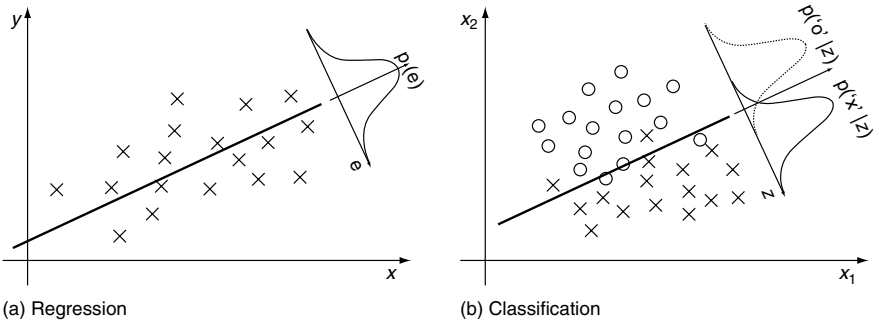

**Fig. 4.7** Illustration of regression (left pane) and classification problems (right pane). In a regression problem, the goal is to approximate as best as possible the dependent variable (y-axis) given the independent variable(s) (x-axis). In classification, the goal is to separate the classes “o” and “x” as a function of the explanatory variables  $x_1$  and  $x_2$ . The score  $z$  reduces the multivariate classification problem to one dimension.

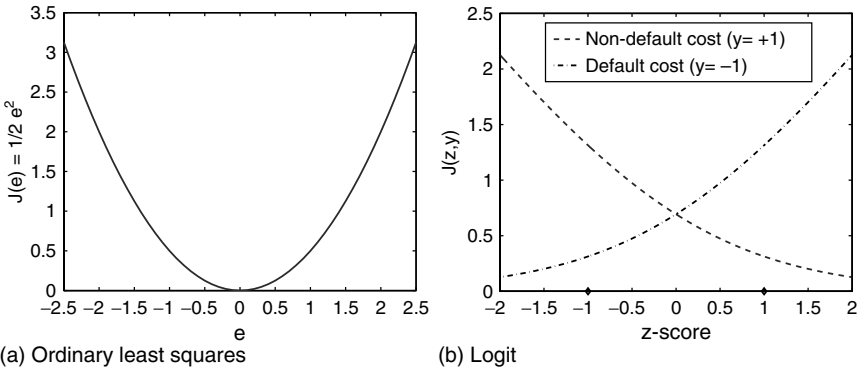

**Fig. 4.8** Reference cost functions for regression (OLS, left pane) and classification (logit, right pane).

The errors  $e_i$  become smaller for good choices of the parameters  $w_1, \dots, w_5, b$ . A classical cost function is to minimize the mean squared error (MSE) by choosing the optimal parameters  $w_1, \dots, w_5, b$ :

$$\min_{w_1, \dots, w_5, b} \mathcal{J}(w_1, \dots, w_5, b) = \frac{1}{N} \sum_{i=1}^N \frac{1}{2} e_i^2. \quad (4.14)$$

The cost function is visualized in Fig. 4.8a. The corresponding regression problem is known as ordinary least squares (OLS). The factor 1/2 is typically introduced to simplify notation of the derivatives of the cost function.

Binary classification problems, visualized in Fig. 4.7b, concern the problem of discriminating between two classes, “good” and “bad”. Ordinal classification problems concern the discrimination between multiple, ordinal categories, e.g., “very good”, “good”, “medium”, “bad”, and “very bad”. For default risk, the industry standard is logistic regression (logit) that relates the  $z$ -score to a default probability via the logistic link function

$$p(y = -1|z) = \frac{1}{1 + \exp(z)}. \quad (4.15)$$

The non-default probability  $p(y = +1|z)$  is the complement  $\exp(z)/(1 + \exp(z))$ . The parameters of the score function need to be determined such that a high score is given to non-default observations ( $y = +1$ ) and a low score to default observations ( $y = -1$ ). For logistic regression, one typically formulates the estimation problem in terms of a maximum likelihood problem. The parameters  $w_1, \dots, w_5, b$  are estimated such that the data are explained the best, i.e. that a low probability is assigned to non-defaults and a high probability to the default observations. The corresponding cost function is visualized in Fig. 4.8b. The link function is visualized in Book II, where more statistical properties are also discussed.

Other classification techniques with different cost functions are Fisher discriminant analysis (FDA), probit regression, linear or quadratic programming problems. The latter are closely related to linear support vector machine classifiers [12, 188, 349, 357, 379, 475, 495]. Details on classification algorithms are provided in Book II. The use of logit is preferred over the regression-based least squares cost function [160, 337, 512]. Extensions of the binary classification problem ( $-1, +1$ ) towards the ordinal multiclass problem (AAA, AA, A, BBB, BB, CCC, D) are also discussed in Book II. The cost function formulation is often closely related to the numerical optimization algorithm to find the optimal model or model parameters.

One has to take care not to merely optimize the model parameters towards the learning data set, but instead estimate them so as to avoid overfitting and guarantee sufficient generalization ability on new, unseen counterparts. The estimation of the model parameters may not only optimize the discrimination on the learning data set, but also has to consider sufficient generalization ability on new observations. This can be done by evaluating the performance on an independent validation or test set, Bayesian learning theory or statistical learning theory as explained in Book II.

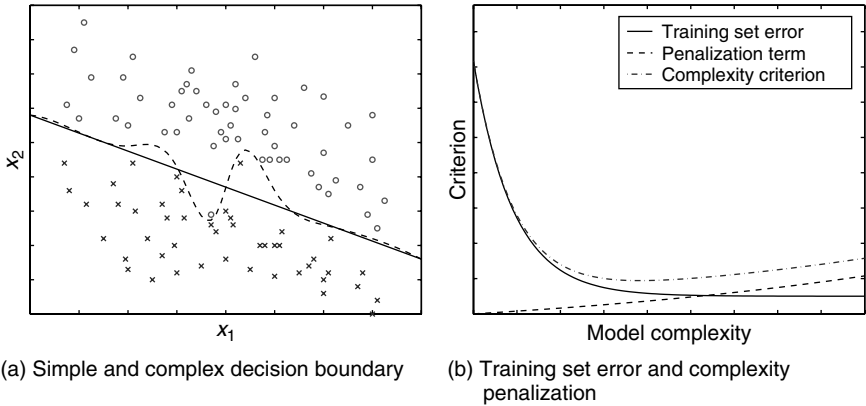

**Fig. 4.9** Model complexity trade-off. The left pane depicts a binary classification problem with classes “o” and “x” as a function of the explanatory variables  $x_1$  and  $x_2$ . The simple classifier (full line) does not have the classification accuracy of the complex classifier (dashed line), which classifies 2 points more correct, but with the cost of a more complex classifier formula. The right pane represents the trade-off between training set error and the model complexity term combined in a complexity criterion.

### 4.3.2.3 Model complexity and input selection

More complex models can capture more complex relations in the data but may also tend to “memorize” the training data instead of learning true relations between the explanatory variables and the target variable (see Fig. 4.9). The model complexity is often related to the (effective<sup>32</sup>) number of parameters.

The number of parameters grows with a more complex model structure, e.g., a neural network structure (Fig. 4.5(c)) with more hidden neurons or with an increasing number of explanatory variables. A correct statistical design requires a balance between a simple model and a good result on the training data. A more complex model may provide a better or closer fit on the training data, but the performance improvement may be too limited to justify the model complexity. A more complex model has a higher risk of data memorization and poor generalization on new test data points on which the model will be applied in practice.

Statistical inference techniques allow verification of the statistical reliability of the estimated parameters in the model. Unreliably estimated parameters are put to a default value (mostly zero) such that it has no impact

<sup>32</sup> The notion of effective number of parameters is often used in the context of Bayesian modelling. The use of prior knowledge reduces the total number of parameters that needs to be estimated in the model.

## 190 Risk modelling and measurement

in the model structure. Complexity control is achieved by refusing the use of insufficiently stable parameters in the model. The stability of a parameter estimate is typically assessed via statistical hypothesis testing. Complexity criteria are an alternative technique that penalize unnecessarily complex models

Complexity criterion = Training set error + Complexity penalization.

With increasing model complexity, the training set error will decrease. At the same time, the penalization term will increase. From a certain point onwards, a further complexity increase will only result in a small reduction in the training set error that will no longer be offset by the complexity penalization. Model complexity control by complexity criteria is achieved by choosing the model with the lowest criterion value. Complexity criteria embody Occam's razor principle<sup>33</sup> by avoiding unnecessarily complex models. Complexity criteria approximate the generalization behavior. With sufficient data available, complexity control can be achieved by model evaluation on an independent validation or test set.

The model complexity issue is closely related to the choice of the number of input variables as well as the selection. The variable selection problem is not only concerned with the number of explanatory variables, but also with the actual choice of a limited number of variables out of a large set of candidate explanatory variables. There exist multiple algorithms to perform both input selection and model control that are discussed in Book II.

Both the related problem of model complexity and input selection are difficult problems. Often there is a flat optimum achieved by a set of models with similar statistical performance. It is useful to compare the model characteristics and model outputs on a set of reference cases with financial experts to make the final choice.

### 4.3.2.4 Model evaluation

For the model evaluation one needs to decide upfront which criteria will be used to compare different model possibilities. The model is preferably evaluated on a fully out-of-sample test set that was in no way used to design the statistical model. Where possible, the test set is also an out-of-time

<sup>33</sup> William of Ockham (1285–1349) was born near the village of Ockham in Surrey (England) about 1285. He was an influential philosopher of the fourteenth century and a controversial theologian. He favored the principle that simple explanations are preferred above unnecessarily complex ones: "Entia non sunt multiplicanda praeter necessitatem (Entities should not be multiplied unnecessarily)".

dataset that consists of data gathered in time after the training data used for the design. The data sample used to estimate the model is referred to as the training data sample or reference data set. Performance measures on the training data are called in-sample performances.

The model evaluation is done using different criteria that evaluate the quality of the model calibration to verify that the model indicates on average that the estimated risk is in line with the risk observed in the data. For default risk models, one tries to assess the ability to discriminate between good and bad counterparts. For continuous variables, one measures how precise the predicted values are with the observed values. A migration analysis learns how stable the model outputs are and whether they show unnecessary migrations.

The performance evaluation needs to be done on the whole dataset and the internal perimeter. For models that cover a large perimeter with different counterpart types, industry sectors and geographical regions, it is useful to evaluate the performance on these different segments. On top of a statistical evaluation, it is useful to perform a financial expert evaluation of the large model errors. A human expert evaluation will reveal possible shortcomings of the data definition and of the financial quality of the model.

### **4.3.3 Expert models**

Expert models have the same structure as statistical models, the difference is that the parameters are determined by financial experts, not by statistical estimation procedures. Expert models formalize the rating process in the case of low data availability and provide a medium to pass knowledge from experienced analysts to junior analysts in the organization. Because the expert models are not empirically determined on the data, they have similar potential weaknesses as expert human judgment. The advantage of expert models is their financial intuition and the definition of an explicit rating framework. The latter allows formal verification of the expert assumptions and the model to be updated when data becomes available. The properties of expert models are partially those of empirical statistical models and partially those of expert human judgment. Expert models are, at least partially, often used in low default portfolios.

### **4.3.4 Expert human judgment**

Traditional credit analysis relies upon expert human judgment. Financial experts analyze the financial statements, the global economic context the



counterpart is operating in, the management strategy and efficiency and the future outlook of the counterpart. They also calculate financial ratios, analyze the performance of the firm on the main ratio types (profitability, solvency, liquidity, leverage, . . .) and their evolution in time. All this information is then summarized by the expert or expert committee into an expert human judgment of the firm.

The strong points of expert human judgment are the capability of analyzing and interpreting the information in detail, as well as the ability to do further research on strengths, weaknesses and judge the impacts of opportunities and threats. Good financial experts are able to stay consistent overall, but can look and interpret correctly all details in exceptional cases. Financial experts with a long track record case also rely on a rich experience and in-depth understanding of the sector they are working in. In the past, (external) ratings were assigned by experts or committees of experts. The historical rating performance indicates the relative success of failure prediction.

A weak point of expert judgment is the lack of transparency in the decision-making process. Information from different sources needs to be combined, which is a complex task for humans. How should one rate a firm with AA on liquidity, BBB on profitability and BB on leverage? It is difficult to quantify and record how the different information is processed and weighted to come up with the final rating. However, such information is highly interesting when one needs to correct or fine tune the internal rating process, e.g., when backtesting results indicate low discrimination between good and bad counterparts. Whereas the risk management function is clearly separated from commercial activities in the bank to warrant correct and objective risk assessments, the opaque human expert rating process may still yield the perception of an important room for subjective decision making. Another disadvantage of human expert ratings is the lack of consistency and reproducibility. The rating result may depend on the analyst, but also on the time and conjuncture and on the team. Consistency in time and place is especially a concern for large financial conglomerates. Of course, one can take appropriate measures to relieve in some sense, most of these concerns. Consistency problems can be solved by introducing central teams that assign or verify group-wide ratings, quality-control teams can provide spot checks to assess the objectivity and clear guidelines can be defined to reduce the impression of subjectivity (e.g., no rating higher than BBB if long-term profitability is less than about 5% as learned from Fig. 4.6b).

Another problem are psychological biases in the human decision-making process. People often tend to overestimate the precision of their knowledge,

people get more confident with the importance of their task and memorize more easily information related to successes than to failures [40]. Because the decision making is less explicit, the rating assignment may be subject to anticipation errors of firms slowly degrading towards a rating cut-off point. Companies that have been followed for a longer term by financial analysts may receive a rating opinion by habituation instead of being based upon the most recent financial figures [304]. As credit risk for most sectors is relatively low (average default rates less than 1 or 5%), feedback on failures is limited and in most cases restricted to anecdotal, instead of statistical, consistent and structured information [378]. The low number of defaults makes feedback even more difficult and suggests that human expert ratings may not be optimized for risk discrimination and calibration accuracy, whereas statistical models are. Many experimental studies in different domains have shown that quantitative statistical models outperformed human experts [129, 333, 353, 428]. Nevertheless, rating agencies have been able to reduce many potential risks by means of rating committees and internal quality-control units that monitor rating consistency across different industry sectors and geographic regions. Organizations can reduce these biases and the potential perception of subjectivity by defining rating templates. In a rating template, the criteria are listed that need to be analyzed before assigning the final rating or risk assessment. The criteria are documented and points are assigned to each criterion according to internal documentation. The final rating is based on the expert combination of the different criteria, not on a mathematical formula or rules. When sufficient data becomes available, such a model can be estimated.

Of course, statistical models can also have biases and may not be optimally discriminant because of changed macroeconomic circumstances, sector changes or just because of lack of sufficiently large databases to develop a statistical model. However, the transparency and consistency of quantitative models makes insufficient discrimination and calibration biases easier to detect and correct. For supervision by auditors and regulators, quantitative models are much easier to monitor.

When statistical databases are lacking, the judgment can only be made based on human expertise, where depending on the importance of the decision, a committee of experts can make the decision. Rating templates can provide a temporary solution before sufficient data and formal knowledge are available to construct an expert model or even a statistical model.

Also for other sectors, for which models have been built on sufficient data, human expertise remains necessary to monitor and control the validity of

the model output. Statistical models are ideally parsimonious for reasons of stability and reliability. In this sense, statistical models need to be general and cannot capture all details, especially when estimated on relatively small databases. Human experts can bring added value as they can process much more information and also take into account partially updated information (quarterly results, success/failure of new products, . . .) in the decision process. Human expert judgment is often reported to increase accuracy on top of statistical models. Ratings resulting from both statistical models and human judgment are current practice in most banks.

### 4.3.5 Direct and indirect models

Models can be constructed to predict directly the target variable or to predict an intermediate result that serves to compute the final prediction of the target variable in a deterministic model. The latter are called indirect models: scoring systems predict directly the intermediate variables that are then used indirectly to produce a global risk assessment. An advantage of indirect modelling is that the predicted variables can then also be used for other purposes, e.g., profit scoring. Moreover, one can easily change the definition of target variables by simply reformulating the deterministic model without having to re-estimate the prediction model [306, 332]. A disadvantage is that more models are required; that the deterministic models do not take into account all correlations between the intermediate variables and that one optimizes the prediction of an intermediate variable instead of the target variable. In [332], it is illustrated after extensive model development that the indirect approach can give competitive results with the direct approach. Figure 4.10 illustrates the difference between the direct and the indirect credit scoring approach.

Indirect models are often applicable in practice, not least because the global model is too complicated to be estimated in one step or there is not sufficient data available from one source. One example of indirect modelling is the mapping to external ratings using the rating scheme of Fig. 3.3. The complete process of financial strength rating, support and country ceiling is very complex and often not all information is available in large databases. Often too little information is systematically available to determine mother support. The number of straightforward mathematical techniques to model the whole rating process of Fig. 3.3 is very limited. When one determines the financial strength rating from a mapping to external financial strength ratings, this modelling exercise is an

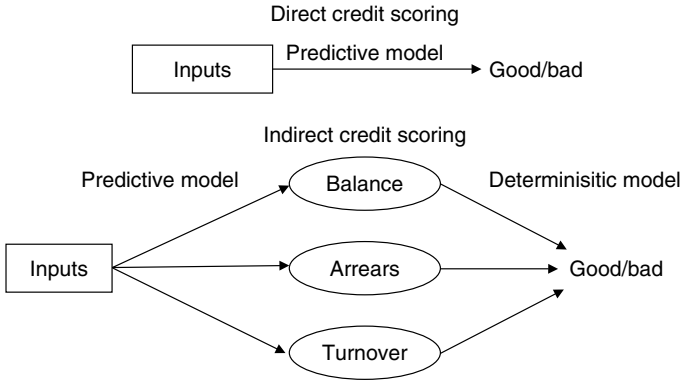

**Fig. 4.10** Direct versus indirect credit scoring models. The top sketch illustrates a direct predictive model. The bottom sketch depicts an indirect model that uses 3 predictive models to predict the intermediate variables balance, arrears and turnover.

indirect modelling step in the global approach to determine the long-term rating.

For LGD models, one often uses the following type of “white box” models:

$$LGD = LGD_{uns} \underbrace{\left[ 1 - \frac{HC \cdot C}{EAD} \right]}_{\text{net exposure}}_+, \tag{4.16}$$

where the net exposure is limited between 0 and the EAD. The haircut (HC) indicates the proportional amount of value reduction for the collateral asset (C). Haircuts take into account impacts of exchange-rate fluctuations, maturity mismatches, . . . While LGD data is usually available in a limited way, for some collateral types (financial assets) the haircuts can be derived from market price fluctuations<sup>34</sup>. For some applications, it is therefore useful to model the unsecured LGD instead of the LGD.

For letters of credit, that can be drawn if certain conditions specified in the covenant are met, one expresses the possible outcomes in the graphical model of Fig. 4.11. The letter of credit represents a guarantee that is, e.g., drawn if the default concerns a specific bankruptcy event. The high CCF value can be close to 100%, while the low CCF value will be 0%. Instead of modelling the CCF values, it is more straightforward to model the intermediate probability that the covenant conditions will be met.

<sup>34</sup> For financial collateral, specific estimation methods have been described in the new Basel II Capital Accord, as will be explained in Chapter 6.

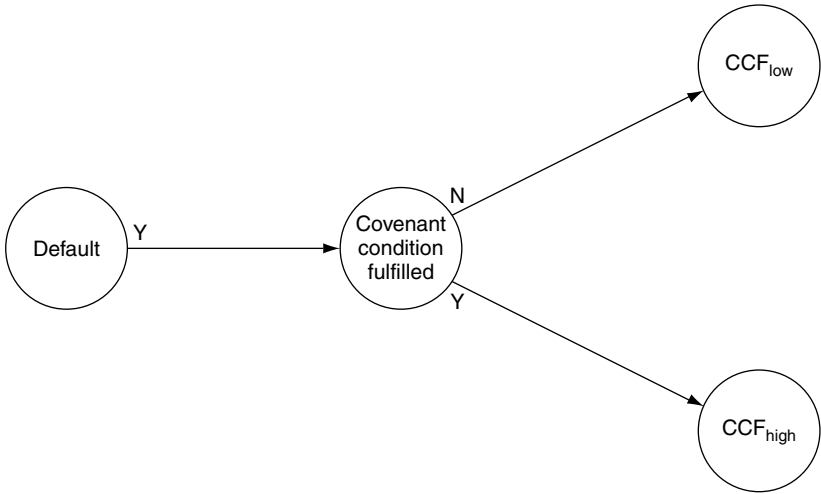
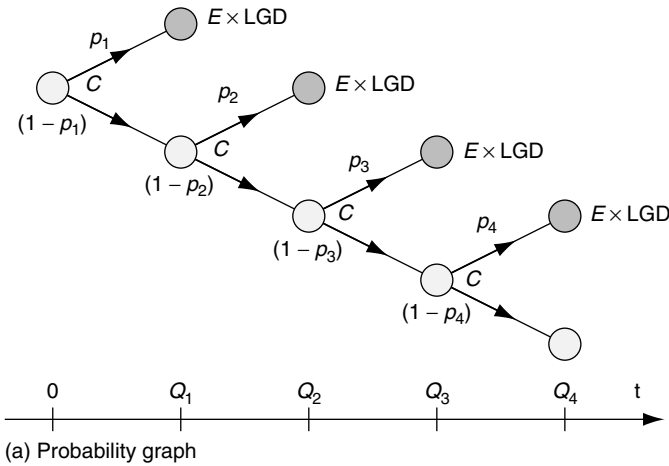

**Fig. 4.11** Graphical model illustrating the CCF for a letter of credit that is only drawn when certain covenant conditions are met.

Figure 4.12 represents an alternative example of a graphical probability model for the pricing of the credit default swaps (CDS) depicted in Fig. 1.15. The probability model allows evaluation of the cash flows in the case of default and non-default for the protection buyer and seller. The required model inputs are the amount  $E$  for which protection is bought, the quarterly premium  $C$ , the loss given default (LGD) and the discount rate  $r_{0x}$  (e.g., LIBOR) to discount cash flows at time  $t = 0$  to time  $t = x$ . In the example, the protection buyer pays every quarter the premium  $C$  in return for protection in case of default. The CDS is physically settled, in the case of default, the protection buyer gets  $E$  in exchange for the protected underlying from the protection seller, who incurs a net loss of  $E \times \text{LGD}$ . A correct pricing of the CDS implies that the net present values of the expected cash flow of the protection buyer equals that of the protection seller. The default probabilities  $p_1, p_2, p_3$  and  $p_4$  are derived from historical experience or from the credit spread curve. Note that there also exist other CDS pricing models, e.g., based upon arbitrage theory [268, 269].

#### 4.3.6 Combined models

A combination of credit scoring by applying human judgment and quantitative statistical models aims to improve both stand-alone techniques where



Default	Prot. buyer	Prot. seller	Probability
$Q_1$	$C$	$E \times LGD / (1 + r_{01})$	$p_1$
$Q_2$	$C + C/(1 + r_{01})$	$E \times LGD / (1 + r_{02})$	$(1 - p_1)p_2$
$Q_3$	$C + C/(1 + r_{01})$ $+ C/(1 + r_{02})$	$E \times LGD / (1 + r_{03})$	$(1 - p_1)$ $\cdot (1 - p_2)p_3$
$Q_4$	$C + C/(1 + r_{01})$ $+ C/(1 + r_{02})$ $+ C/(1 + r_{03})$	$E \times LGD / (1 + r_{04})$	$(1 - p_1)$ $\cdot (1 - p_3)p_4$
No	$C + C/(1 + r_{01})$ $+ C/(1 + r_{02})$ $+ C/(1 + r_{03})$ $+ C/(1 + r_{04})$	0	$(1 - p_1)$ $\cdot (1 - p_2)$ $\cdot (1 - p_3)$ $\cdot (1 - p_4)$

(b) Discounted payment cash flows

**Fig. 4.12** Graphical representation of a probability model (a) to price a physically settled CDS (Fig. 1.15): in the case of a default, a payment  $E$  is made to the protection buyer of the CDS in return for the bond or loan for which protection has been bought. The protection seller loses  $E \times LGD$ . Otherwise, the protection buyer pays quarterly the premium  $C$  in return for the credit protection offered during the next period. The discounted cash flows from the protection buyer and seller payments are reported in the table (b) for each of the possible outcomes.

possible. In practice, this means that human judgment is applied for important risks and exposures. For portfolios with a high number of relatively small exposures (e.g., retail), it is generally too expensive and not efficient to analyze all counterparties. For such portfolios, a human expert analysis is performed on the large and risky counterparties. For less granular portfolios (e.g., large firms, sovereigns), a human expert analysis is applied almost to all counterparties. The most risky counterparties are analyzed more in depth and

more frequently. There are several ways to combine human judgement and quantitative model ratings.

Some credit scoring systems use both quantitative ratios as well as judgmental variables determined by human expertise. Examples of such human variables are management quality and efficiency, disclosure quality, macro-economic environment. Such judgmental variables are typically ranked on a scale with 2 to 10 notches. Two notches are applied, e.g., in the case of yes/no questions, while more refined qualitative rating scales are used for ordinal variables, e.g., very good, good, medium, bad and very bad management. The final score and corresponding rating are obtained in a quantitative way by weighting the quantitative and qualitative variables. Some systems also allow the weights of the qualitative variables to be varied within a defined range, depending on the importance of that variable for the risk analysis of the firm. In order to reduce the possible subjectivity and inconsistency in the judgmental analysis, the meaning of the different values that can be assigned to the judgmental variable, has to be well defined and documented in guidelines.

Another approach is a separate calculation of the judgmental and quantitative rating that are combined into one final rating. Typically, one uses the quantitative rating as the backbone, reference rating. The qualitative rating is taken into account by the overruling, where the final rating in between the quantitative and qualitative rating is assigned. The overruling has to be clearly motivated. The overruling is typically limited within an error band from the quantitative model rating to reduce the impact of possible subjective elements in the final rating. In particular, the upside overruling is limited, whereas for downgrading no limits can be put in place for reasons of conservatism. Large differences between the final and quantitative model rating will be discussed by a committee of experts, and must also be discussed with internal quality control.

An important advantage of the first approach is that the judgmental variables are quantified. In the second approach, the overrides or overrulings are documented, which allows us to synthesize them and store them in databases as well, although less easy than qualitative ratings. Such data can be used to refine the existing models in the future when sufficient data is available to update the model. The use of expert scorecards is a first step in this direction. Besides the fact that these scorecards formalize the rating process and make it more consistent and reduce the possible subjectivity, an important additional medium- and long-term advantage is the storage of the quantified judgmental variables to build a sufficiently rich database to update rating

models in the future. Some rating tools only use judgmental variables that are assigned following detailed internal guidelines; and combine this quantified information in a statistical way.

The combination of the statistical models and human expertise is not limited to the above techniques. Other approaches are possible to combine the strong points of each approach: consistency, transparency and optimized discrimination of the quantitative model and in depth financial and macroeconomic insight and interpretation, broad and detailed financial analysis, interpretation of non-quantifiable information and general sector and economy overview of the human experts.

#### 4.3.7 Example model formulations

There exists a wide variety of modelling techniques. It is useful to know that for most applications, the industry standard consists of a limited number of techniques:

**Default prediction:** For default risk models, the benchmark industry standard is logistic regression, typically performed on a database with quantitative and judgmental variables.

The first step is the discrimination step to separate defaults from non-defaults. Typically, a linear logistic regression formulation (eqn 4.15) is applied. Some models extend the linear model formulation (eqn 4.10) with non-linear variable transformations (eqn 4.11) or apply neural networks (eqn 4.12) and non-parametric techniques (eqn 4.13). In the case of a limited number of defaults, one can also opt to learn the discrimination from delinquency information, when there exists a longer data history. Note that often not the full database is used to determine the score function, a balanced sample with a more or less equal number of good/bad observations is used. Typical good/bad ratios range from 50/50 to 80/20. For large databases, it is too costly to complete all the judgmental variables. In such cases, the judgmental variables are added to the quantitative and objective qualitative variables in a second step on a reduced data sample.

The second and third steps are the segmentation and calibration process. One option is to translate the output of the logistic regression model to an existing rating scale that defines (implicitly) the limits of the internal ratings and the risk levels. An alternative approach is to apply a segmentation criterion to group the scores into homogeneous groups with the same empirical default behavior and different default rates across ratings.



**Mapping to ratings:** The mapping to ratings is applied when the default history is too limited. The resulting score function reflects the expertise of the rank ordering of the ratings.

The discrimination step is similar to default prediction models, except that no subsampling is used to balance the sample and that ordinal logistic regression or least squares regression are applied instead of binary logistic regression. The segmentation is implicitly achieved from the mapping process. Calibration is often based upon historical default statistics from internal/external ratings.

A key point in the mapping process is the comparability of the meaning given to the score function ratings and the used external/internal ratings, e.g., whether ratings reflect PD or EL. When external rating statistics are used for calibration, the comparability of the external default definition with the internal default definition needs to be investigated.

**LGD prediction:** In terms of model structure, both the direct and indirect model approach are applied. In indirect models, the haircut parameters and unsecured LGD are often estimated separately. Simple averages and/or structural models (for financial securities) are often applied for the estimation of haircuts. The estimation of the unsecured LGD is often done using ordinary least squares regression (eqn 4.14), which is the benchmark technique. An appealing property of OLS is that it corresponds to the estimation of the average, which is often required for regulatory calibration purposes. Some modelling techniques apply robust methods to limit the impact of extremely high and low LGD values in the estimation result. LGD values tend to have quite a broad distribution with many values around 0 and 100%, as illustrated in Fig. 4.13.

In direct models, the LGD is estimated, a.o., based upon collateral information. Also here, least squares regression is the benchmark technique for the LGD prediction.

Compared to default prediction, LGD modelling is applied on the product level, while default prediction is done on the customer or counterpart level. Given the low number of observations and the important dispersion of LGD values (Fig 4.13), linear models (eqn 4.10) are the benchmark and non-linearities are more difficult to identify. Segmentation is not always applied, because LGD grades are less frequently defined, especially in the case of indirect models. For Basel II purposes, calibration is often done in downturn conditions: the LGD levels are measured during recession periods or periods of a high number of defaults.

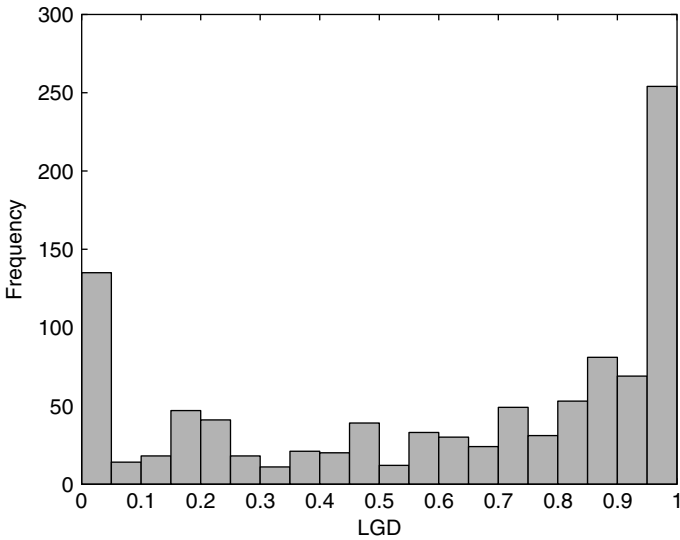

**Fig. 4.13** Illustrative histogram of LGD values, in many cases LGD histograms tend to have a broad distribution with many values around the extreme of 0 and 100%. In the case of a cure, a low LGD value occurs, in the case of a liquidation, higher LGD values up to 100% (and even more) can occur. The LGD values are capped between 0 and 100% in this example.

**EAD & CCF prediction:** The basic techniques for EAD and CCF modelling are similar to LGD modelling. Given that it is a new domain, one often applies an expert product segmentation on which one estimates the average from historical data or resulting from a structural model. For products with historically higher exposure risk, e.g., credit cards, regression techniques are applied.

In the case of limited data availability, expert models and structural models become more important or their importance in the combined model becomes higher. In the case of very low data availability, expert ratings are assigned.

#### 4.4 Data definition and collection

Models need data for their application, design and performance evaluation. Empirical models require historical data to discover historical relations, structural and expert models need less data for the design phase, although it is useful to have some historical data to evaluate the model before actually

**Table 4.1** Overview of data definition and collection aspects. The collection, definition and calculation of target variables is a key task for risk modelling and measurement. More information is available on PD than on LGD and EAD. The definition of these variables is closely related, especially for LGD and EAD. Explanatory variables are collected historically to identify the risk drivers. The selected explanatory variables are also used for model evaluation. In section 4.4.4.6 an overview of example variables for various asset classes is given.

<b>Target variable</b>	<b>section</b>
PD: Default labels	4.4.1.1–2
PD: Delinquency labels	4.4.1.3
PD: PD ratings	4.4.1.4–5
PD: Market information	4.4.1.6
LGD: Workout LGD	4.4.2.1
LGD: Market LGD	4.4.2.2
LGD: Market implied LGD	4.4.2.3
LGD: Expected loss	4.4.2.4
LGD: Recovery ratings	4.4.2.5
EAD: CCF definition	4.4.3.1
EAD: Measurement	4.4.3.2
<b>Explanatory variable</b>	
Quantitative and qualitative data	4.4.4.1
Absolute and relative data	4.4.4.2
Time aspects	4.4.4.3
Variable definition	4.4.4.4
Data sources	4.4.4.5
Examples	4.4.4.6

applying it. All models need data for their evaluation. Table 4.1 provides an overview of the different data aspects.

Recently, data became available in large electronic formats in massive databases. Getting data has become less difficult than before, but the issues of data reliability and data quality remain. Whenever data is used, one needs to identify preferred data sources and give a precise description of the information a data item represents.

The data collection concerns the gathering of target risk data (default cases, loss given default numbers and exposure at default information). Explanatory data fields need to be defined and gathered as well. Observe that for the estimation of default models, one needs both default and non-default counterparts. For LGD and EAD/CCF models, the model estimation and

evaluation is done on the defaulted issuers or issues only. This implies that far less data will be available for the latter type of models. The definitions of these risk measurements are not independent: the definition of the default defines the LGD and EAD/CCF measures. Also, the LGD definition depends on the choice of the EAD definition. Figure 4.14 depicts some possible LGD and EAD/CCF measurements.

#### 4.4.1 Default information

The good/bad labelling is based upon default or distress information. The correct definition has an important impact on the risk measurement in the organization. Before the introduction of the Basel II Capital Accord, banks could freely adopt their own definition of default. Some even distinguished between three categories of payers: good payers, poor payers, and bad payers [140]. The definitions could be based on, e.g., the number of days in payment arrears, occurrence of bankruptcy, negative net present value, unfulfilled claim of more than 1000 dollars, . . . In a retail context, a commonly used default definition was that a customer was assumed to be a defaulter if he had been in payment arrears for more than 3 consecutive months [474]. Different organizations could have different default definitions, resulting in different scoring systems, risk management practices and risk measures. Such differences complicate a straightforward comparison across different organizations and the creation of a level playing field with the same capital requirements for equally risky portfolios. The Basel II capital requirements [63] depend explicitly on the internal PD estimates when using the internal ratings-based approach as explained in Chapter 6.

Among the many definitions of default, some of them are more objective, others are more subjective. With the Basel II default definition, a uniform world-wide default definition will be applied. Although the default definition has become much more objective with the 90 or 180 days delay requirement, there still remains some room for subjective definition by means of the unlikeliness to pay. Observe that with such a definition a default does not always have to result in a loss. Some regulations consider a default when there is a material loss, e.g., more than 5% of the exposure. Such thresholds are called materiality thresholds.

Based upon the database with good/bad labelling definition, models will be evaluated in the backtest procedure. Based upon a historical training database with default labels, a statistical algorithm learns to discriminate between good and bad counterparts. The discriminant score makes use of

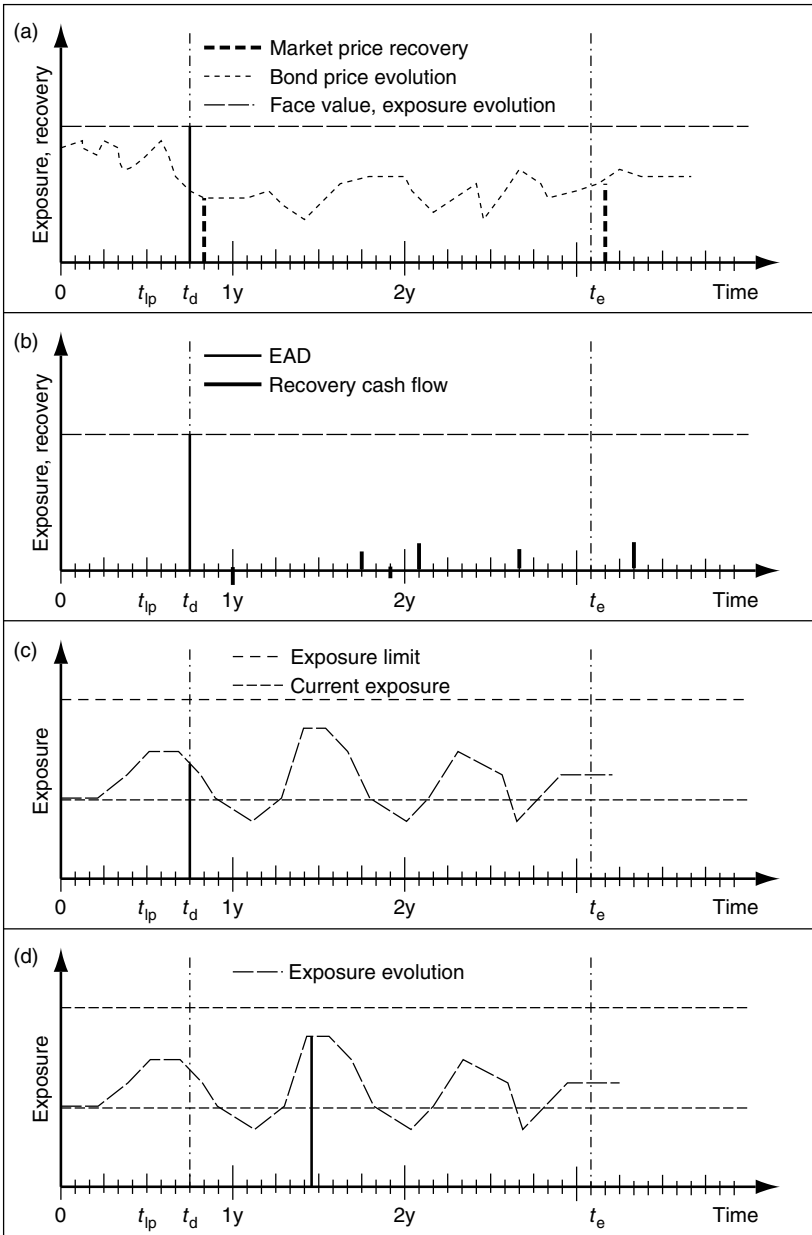

**Fig. 4.14** Timeline of a distressed firm: last payment date ( $t_{ip}$ ), default date  $t_d$  and emergence from default or settlement ( $t_e$ ). The bankruptcy procedure may follow shortly after the default date  $t_d$ . The default definition impacts the LGD measurement and the EAD definition. Panels c and d depict the EAD definition, respectively, as the exposure at default and maximum exposure during default. In panels (a) and (b) the bond LGD is measured via the (discounted) bond market price recovery shortly after default or after emergence or settlement. The LGD can also be obtained from workout recovery cash flows (panel b).

explanatory variables (e.g., debt level, income, expenses, age, . . .) that will be discussed next. Needless to say a correct labelling facilitates the learning process. Once a discriminant score between low- and high-risk counterparts has been estimated, risk classes with coherent default risk are defined and the probability of default (PD) is calibrated. To calculate this default risk, one not only needs to have the number of defaulted counterparts, but also the number of non-defaulted counterparts. In most cases, this corresponds to the number of customers. A simple way to measure the one-year default rate is to define a cohort with the number of customers at January 1 20xx and count the number of counterparts of the cohort that defaulted during the year. Details on default rate calculations are provided in Book III.

Internal in the bank's organization, objective defaults can be flagged automatically by IT systems. Basel II requires that banks have adequate systems to detect defaults. The initial default list may contain erroneous defaults due to insufficiencies in the information systems of the bank (or even the counterpart). Such defaults are called operational defaults and are removed from the automatically constructed default list. Technical defaults occur when the counterpart fails to pay timely due to technical, non-financial reasons, e.g., the paymaster retired and his successor made the payment to a wrong account. Non-operational and non-technical defaults are called real defaults or credit defaults.

The subjective default labelling is typically endorsed by the default committee that ensures the consistent and coherent application of the default definition in the whole organization. The resulting list contains only real defaults. The default labelling process is a key step in the internal risk measurement and is subject to important internal and external audit. The default definition is not only important for the measurement of the default rate, but also for the measurement of the LGD (and possibly also CCF). As illustrated in Fig. 4.15, the qualification rules for technical defaults as either Basel II default or as performing will also impact the LGD measures, especially because these default types result typically in lower loss figures than the other default types. Qualifying more technical defaults as Basel II defaults will increase default rates, but generally will reduce LGD values.

Apart from the default event definition, the bank also needs to specify when a counterpart emerges from default or when the default ends. The counterpart may either cease to exist (e.g., bankruptcy declaration) or resume debt service when the financial situation is cured. When a new default event is triggered after the emergence of default, this is called a recurrent default. It implies that the default is counted twice in the default statistics.

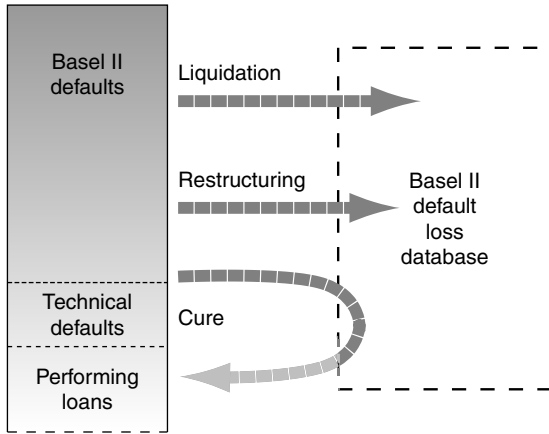

**Fig. 4.15** Illustration of the impact of the default definition on the LGD measurement. Qualification rules for technical defaults will determine the composition of the loss database from which the LGD values are calculated. Because technical defaults have typically lower than average losses, the qualification rules will not only have an important impact on the default rate estimation, but also on the LGD estimation.

For low-default sectors, external rating agencies may have a broader portfolio of rated counterparts and have more reliable long-term statistics. In such cases, it is possible to perform a mapping to external ratings and to use default rates from external agencies statistics when portfolio characteristics and default definitions are similar.

Paragraph section 463 of the ICCMCS [63] requires that banks must have a default history of a minimum of 5 years for at least one data source. If there is one data source with a longer data history that is relevant and material, this longer time period must be used.

#### 4.4.1.1 Basel II default definition

A default is considered to have occurred with regard to a particular obligor when either or both of the two following events has taken place (section 452 ICCMCS [63]):

1. The bank considers that the obligor is unlikely to pay its credit obligations to the banking group in full, without recourse by the bank to actions such as realizing security (if held).
2. The obligor is past due more than 90 days on any material credit obligation to the banking group. Overdrafts will be considered as being past due once the customer has breached an advised limit or been advised of a limit smaller than current outstandings.

For some asset classes, like public sector entities, a default can be defined by the local supervisor after 180 days instead of 90 days. The elements to be taken as indications of unlikelihood to pay include (section 452 ICCMCS [63]):

1. The bank puts the credit obligation on non-accrued status.
2. The bank makes a charge-off or account-specific provision resulting from a significant perceived decline in credit quality subsequent to the bank taking on the exposure.
3. The bank sells the credit obligation at a material credit-related economic loss.
4. The bank consents to a distressed restructuring of the credit obligation where this is likely to result in a diminished financial obligation caused by the material forgiveness, or postponement, of principal, interest or (where relevant) fees.
5. The bank has filed for the obligor's bankruptcy or a similar order in respect of the obligor's credit obligation to the banking group.
6. The obligor has sought or has been placed in bankruptcy or similar protection where this would avoid or delay repayment of the credit obligation to the banking group.

Guidance on the practical implementation are provided by national supervisors. The Basel II definition applies at the obligor/issuer level. As an exception, for retail the definition can also be applied at the product/issue level. To count the number of days past due, one needs to define clear rules for re-aging the number of days past due. For overdrafts, days past due commence once the credit limit by the bank is exceeded. When no limit has been defined, the limit is considered to be zero. The Basel II default definition is implemented via the local supervisor.

Whereas Basel II specifies the beginning of the default event, the end of the default is not defined. Such definitions are also important in cases of subsequent defaults of the same issuer. Some possible emergence of default definitions are: the bankruptcy process is closed and there are no further recoveries; the default is completely cured with repayment of all debt and accrued interest; closure of a long-lasting default with no recoveries in the last year. Both beginning and end of the default definitions can have a direct impact on the default rates, depending on the end-of-default definition. The same obligor may default many times but in the default rate calculations, all events are subsequent events of the same default. The emergence date also impacts the end of the workout period and the LGD calculation. Different



regulatory capital rules and internal risk management policies are applicable in the case of default and after default.

### 4.4.1.2 Agencies' default definitions

Rating agencies have been applying their own default definitions for a long time period and will continue to use them. Rating agencies report default statistics on a periodical basis as a service to the investor community. The default definition used to measure the default rates is an important aspect when comparing default rates across agencies or applying them for internal use. Table 4.2 provides an overview of the default definitions reported in [234, 375, 500].

Differences in default definitions are important to address when using external rating statistics. In summary, Moody's considers a default on the first day, while S&P and Fitch consider a default in the grace period (10–30 days). Basel II considers a grace period of 90 or 180 days, where the 180 days is only valid for specific asset classes. On the other hand, the “unlikely to pay” aspect of the Basel II default definition corresponds to external ratings around CCC/Caa. External rating agencies typically do not measure the default amount with respect to the full amount due or current exposure, while Basel II allows for some materiality effects, especially in the case of an unlikely to pay default. Another interpretation may result in a threshold level of loss. For example, a 5% materiality threshold was proposed in 2006 in discussions between the Institute of International Bankers and US Banking Agencies regarding Basel II issues.

External rating agencies may count more bond defaults than loan defaults, while banks may count more loan defaults than bond defaults. Basel II indicates that obligor defaults have to be counted. According to section 462 of the ICCMCS [63], banks can use external default statistics on condition the default definitions are compared and – to the extent possible – the impact of the difference in definitions is analyzed.

### 4.4.1.3 Delinquency definitions

Scoring systems were already applied a long time before Basel II was introduced, to automatize the risk analysis and credit approval process. Therefore, banks were using their internal delinquency definition a long time before the Basel II default definition. Roll-rate analysis can be used in order to gauge the stability of the default definition adopted. In roll-rate analysis, one investigates how customers already in payment arrears in one period, move to a

**Table 4.2** Default definition of Moody's, S&P and Fitch [234, 375, 500].

**Moody's** definition of default includes three types of credit events [234]:

1. A missed or delayed disbursement of interest and/or principal, including delayed payment made within a grace period;
2. Bankruptcy, administration, legal receivership, or other legal blocks (perhaps by regulators) to the timely payment of interest and/or principal;
3. A distressed exchange occurs where:
  - (a) the issuer offers bondholders a new security or package of securities that amount to a diminished financial obligation (such as preferred or common stock, or debt with a lower coupon or par amount, lower seniority, or longer maturity); or
  - (b) the exchange had the apparent purpose of helping the borrower avoid default.

The definition of a default is intended to capture events that change the relationship between the bondholder and bond issuer from the relationship that was originally contracted, and that subjects the bondholder to an economic loss. Technical defaults (covenant violations, etc.) are not included in Moody's definition of default. In Moody's default research, secondary and tertiary defaults are reported only after the initial default event is believed to have been cured. This is to ensure that multiple defaults related to a single episode of financial distress are not overcounted.

**Standard & Poor's** uses the following definition [500]:

A default is recorded on the first occurrence of a payment default on any financial obligation, rated or unrated, other than a financial obligation subject to a bona fide commercial dispute; an exception occurs when an interest payment missed on the due date is made within the grace period. Preferred stock is not considered a financial obligation; thus, a missed preferred stock dividend is not whenever the debt holders are coerced into accepting substitute instruments with lower coupons, longer maturities, or any other diminished financial terms.

Issue ratings are usually lowered to "D" following a company's default on the corresponding obligation. In addition, "SD" is used whenever S&P believes that an obligor that has selectively defaulted on a specific issue or class of obligations will continue to meet its payment obligations on other issues or classes of obligations in a timely matter. "R" indicates that an obligor is under regulatory supervision owing to its financial condition. This does not necessarily indicate a default event, but the regulator may have the power to favor one class of obligations over others or pay some obligations and not others. "D", "SD", and "R" issuer ratings are deemed defaults for the purposes of this study. A default is assumed to take place on the earliest of: the date S&P revised the ratings to "D", "SD", or "R"; the date a debt payment was missed; the date a distressed exchange offer was announced; or the date the debtor filed or was forced into bankruptcy.

**Fitch** defines default as one of the following [375]:

1. Failure of an obligor to make timely payment of principal and/or interest under contractual terms of any financial obligation;
2. The bankruptcy filing, administration, receivership, liquidation, or other winding-up or cessation of business of an obligor; or
3. The distressed or other coercive exchange of an obligation, where creditors were offered securities with diminished structural or economic terms compared with the existing obligation.

## 210 Risk modelling and measurement

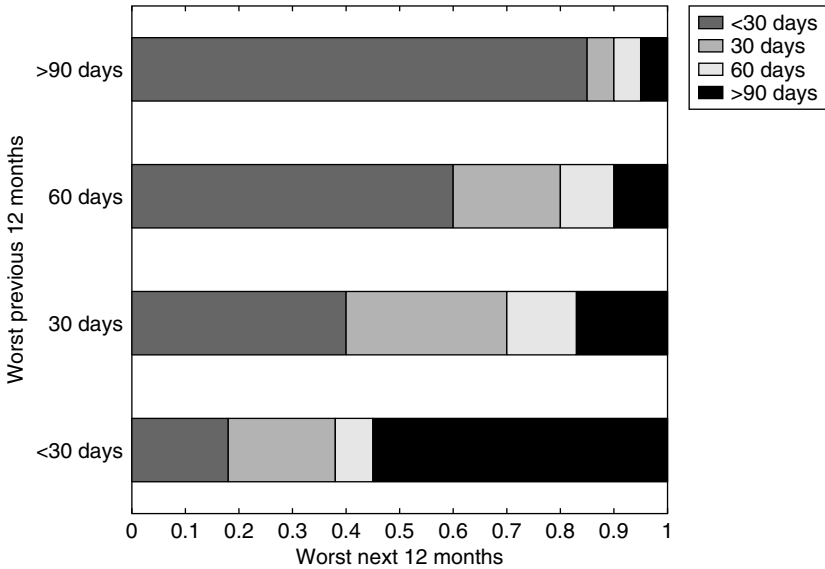
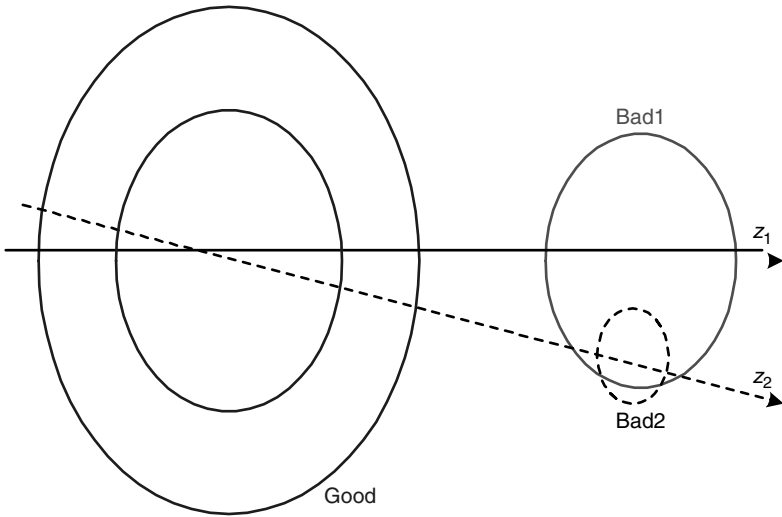

**Fig. 4.16** An example roll-rate analysis graph depicting how customers move between different payment arrears periods. It can be observed that 90 days is a fairly stable default cut-off.

more or less severe default status in the next period. Figure 4.16 provides an example of roll-rate analysis. It can be seen that once customers are 90 days in payment arrears, most of them will keep this delinquency status for the next period and only a small minority will recover. Hence using 90 days as a cut-off for the default definition seems a stable and viable option. Markov chains are essentially a more advanced approach of doing roll-rate analysis where one models the transition probabilities of moving from one default state to another during one period of time.

These “old” internal definitions can be strongly integrated into the bank’s procedures, risk management and workout decisions. In such cases, a bank may opt to perform the scoring on the internal default definition, but may use the calibration with respect to the Basel II definition for regulatory capital requirements. A word of caution to such approaches has to be mentioned because such approaches may not be compliant with the use test and may therefore be disputed by the regulator.

Fewer problems can be expected when the internal default definition encompasses the Basel II default definition. From a theoretical perspective, a different good/bad labelling can result in different scoring functions. The first good/bad labelling does not yield the optimal discriminant score for the



**Fig. 4.17** Illustration of the good/bad definition on the score function. The first definition good/bad1 yields the score function  $z_1$  (full line). The second definition good/bad2 results into the score function  $z_2$  (dashed line). The optimal score function  $z_1$  for the first definition is not necessarily the optimal score function for the second definition and vice versa.

second definition and vice versa, as illustrated in Fig. 4.17. In practice, it is useful to analyze such differences when the differences in default labelling definitions are important.

Due to historical reasons, bankruptcy rates have been reported by national offices of statistics or central banks. Databases with bankruptcy information have a much longer history than databases with internal defaults. Even today, bankruptcy databases can be still much richer because bankruptcy information is available from the public domain, while default information<sup>35</sup> is not. For such reasons, the bank can opt to develop its scoring function on bankruptcy information instead of internal default information. This is especially interesting for banks with high-quality portfolios with a limited number of defaults. The calibration is done on the bankruptcy definition and corrected proportionally with the default/bankruptcy rate. From Fig. 4.17 it is known that it remains useful to evaluate the soundness of the calibration on the default database itself, for example, using backtest techniques explained in Book III. Such tests should be performed on all relevant sectors

<sup>35</sup> Data availability may vary across different countries and regions.

and regions to reveal possible differences in the proportionality conversion. An alternative is to develop the score function on bankruptcy data and calibrate the default risk of the scores using the default database. Calibration techniques, also for low default portfolios, are discussed in Book II.

For comparing default definitions, it is useful to compare default types, qualitative default definitions, days of payment delays and materiality thresholds.

### 4.4.1.4 External ratings

External ratings provide a professional opinion on the default risk of the counterpart. External rating agencies have developed a high level of competence to analyze the risk of bonds and obligors. Most rating agencies report their risk assessment on an alphanumeric rating scale that rates the risk from very low (AAA/Aaa) to very high (CCC/Caa). Although an external rating provides in most cases an ordinal risk assignment and not an indication of the level of default risk, statistics of defaults and losses per rating category are reported periodically, see, e.g., Fig. 3.2a.

For key asset classes like large firms, banks, insurance companies and countries, external ratings cover a large part of the population. In the case of a low number of defaults, it becomes difficult to learn to discriminate between good and bad counterparts as the number of bad ones is too limited. Therefore, external ratings can provide a much larger information set to learn to discriminate between good and bad counterparts. The scoring function mimics the external ratings and the corresponding analyses of the rating agencies. Such an approach is known as a *mapping to external ratings*. The use of external ratings is described in section 462 of the ICCMCS [63]. Apart from learning from external ratings, one can also translate or map internal risk grades to external ratings and use external default statistics when certain conditions are satisfied.

Nevertheless, a mapping to external ratings implies that one relies upon the expert knowledge of external rating agencies. External rating agencies have a good reputation on default risk prediction. The main agencies have been recognized in the US as Nationally Recognized Statistical Organizations and with Basel II, many other (local) agencies will get an External Credit Assessment Institution (ECAI) label that recognizes the proven predictive power of the ratings. Besides learning the discrimination from external ratings, it is also useful to check the behavior of the scoring function on known past distressed cases. Such analysis provides a qualitative idea on the performance

of the scoring for its main purpose: discrimination between good and bad counterparts. A second motivation to analyze stressed cases is that the learning process may tend to emphasize discrimination between moderately good and bad counterparts. Note, however, that it may be less efficient to learn to discriminate between ratings than between solvent and non-solvent counterparts, which actually matters for losses in hold-to-maturity portfolios. A similar reasoning as illustrated in Fig. 4.17 may be applicable. Therefore, it is also useful to measure the accuracy of the scoring function on the full rating scale, especially for financially distressed or defaulted counterparts.

From a practical perspective, the mapping to external ratings may also be perturbed by non-financial elements that may influence the external rating. The scoring function based on qualitative and quantitative financial information of the counterpart is not able to capture non-linear elements like country ceiling, mother ceiling or support that have a strong non-linear impact on the external long-term rating. Given that these elements are not included in the explanatory database and given the strong non-linear effect of the ceiling and flooring, they contaminate the database when one wants to estimate a scoring function<sup>36</sup> to determine the stand-alone default risk. Such elements create a large number of outliers that may significantly disturb the modelling process as follows:

1. Counterparts with good financial ratios may have either a good or bad rating depending on whether the country ceiling is applicable or not.
2. Counterparts with bad financial ratios may have an unrealistic good long-term rating because there is significant support from a strong state or holding company.

It is not unrealistic that such elements are largely present in most sectors. In order to avoid estimation of the stand-alone rating score function being perturbed by these elements, one should clean the database of these elements. The long-term rating will then be based on the financial strength rating from the estimated scoring function and the sovereign ceiling and support effects as depicted in Fig. 3.3. The latter two elements will be introduced in the rating decision tool in a next step using an indirect modelling approach.

Given the current Basel II requirements of internal assessments for default and loss severity risk separately, internal default ratings should reflect default

<sup>36</sup> Typically, one designs an internal rating system by identifying separately the building blocks of the financial strength scoring function, support floor scoring function, country/mother ceiling. These building blocks are then combined into the full internal rating system of Fig. 3.3.

risk. One should be careful to use external ratings that reflect the total credit risk, i.e. the combination of default and loss risk. In such ratings, the same counterpart may have different ratings depending on the priority of the debt (senior, junior) in case of default. Such practices are well known by the notching-down practice of subordinated debt: the rating of subordinated debt is “*x*” notches below the rating of the senior debt issue of the counterpart, where “*x*” depends upon the seniority of the specific issue as explained in Table 3.7. In such cases, one can develop the financial strength rating system on a specific set (e.g., only senior) of debt issues. Moody’s has recently published its senior ratings algorithm to allow for a comparison of ratings due to the issuer specific differences rather than issue specific difference in, e.g., seniority [231]. The notching of secured, subordinated and preferred stocks with respect to senior unsecured bonds for *issue* ratings is a well-known practice [99]. Basel II requires *issuer* ratings that reflect the PD risk.

### 4.4.1.5 Internal expert ratings

Internal ratings reflect internal human expertise on the credit risk of the counterpart. Although the use of pure human expert ratings is highly debated, in some niche markets the data is too limited to develop statistical models. In these circumstances, internal expert ratings are a good alternative to build a statistical model to introduce consistency and reproducibility in the decision-making process. This is especially true when the internal ratings used for the model development are assigned by a domain expert or by a committee of experts. Mathematical models learn from the experts and are an indispensable tool to distribute firm-wide the expert knowledge in a consistent manner. Statistical models are also better suited to perform backtesting of the rating performance.

Similar as for external ratings, the data needs to be cleaned of sovereign ceiling and support effects. Furthermore, one needs to analyze consistency between the internal ratings and the purpose of the rating system being developed.

### 4.4.1.6 Market information

In the absence of default information, one can use market price information to infer the risk of a specific product. There are many other types of risk apart from credit risk that also influence the market price, among others, liquidity and inflation risk. The credit risk itself is composed of default risk, recovery

risk and exposure risk. In particular, the default risk and recovery risk are present in most market instruments. Of course, specific products may also transfer or mitigate exposure risk.

The challenge is to extract all this information from a time series of market prices of products of the same issuer. Among the different market instruments, the most important are:

**Bond prices:** The interest rate of a bond has 5 main components. Each component reflects a form of compensation for the lender: the real interest rate, the inflation, the liquidity risk premium, the credit risk premium and the tax rate. The remaining part is captured by the residual risks. The interest rate spread of a bond is the difference between the bond rate and a reference rate like the government bond rate or the interbank<sup>37</sup> rate. Because the liquidity premium on liquid bonds amounts to only 1 or 2 basis points, this type of risk can be neglected in a first analysis for well-traded bonds. The tax rate is imposed on the bond and may differ between countries and states.

Bond issues often have a credit rating, provided by a rating agency, such as from Moody's, Standard & Poor's or Fitch. Depending on the credit-worthiness, the credit rating and the interest rate spread over the risk-free interest rate will differ. Bonds with a lower credit rating are forced by the market to deliver a higher premium than bonds with a higher rating. Higher bond yields will then, all other elements remaining equal, correspond to higher credit risk. Specialized methods exist to derive PD and/or LGD information from the bond interest rate spread. By comparing issues with different seniority, with the same maturity and of the same issuer, the impact of the difference of the LGD is observed. By comparing a pool of issues with approximately the same loss risk, the same maturity, but having issuers with different ratings, an important part of the differences in the spread is due to the differences in the default risk.

**Equity prices:** The Merton model discussed above looks at a company's equity as an option on the assets of the company. The equity is seen as a call option with a strike price equal to the repayment required on the debt. The probability of default is represented by the probability of exercising the option. The option price reflects the probability of default and the loss given default, both can be summarized in the expected loss. Under

<sup>37</sup> When comparing interest rates of bonds with different coupon payments, etc., it is more convenient to compare yield differences as explained in the next chapter.



rather simple model assumptions, the PD and LGD follow from the well-known Black–Scholes formula for option pricing. In practice, a more complex model is applicable as explained in section 4.3.1.1. The required information to get the market-implied PD and LGD out of equity prices contains the volatility of the equity, the short-term risk-free interest rate, the current value of the equity, the amount of debt interest to be repaid and the amortization structure of the repayments.

**Credit default swap rates:** The market-implied LGD can also be deduced from credit default swap rates. Suppose an investor swaps a company's fixed-rate bond for a floating-rate, LIBOR plus  $x$  basis points. In this case, the investor no longer bears the risk of the company defaulting on the debt. Given the shape of the LIBOR curve, discounting the spread of the fixed rate over the LIBOR rate yields the present value of the expected loss of default. From this information, one can derive the loss given default.

Most of the theoretical models result in so-called risk-neutral risk measures. A risk-neutral risk measure is obtained from the market price under the assumption that an investor is neutral against risk taking. Most investors are risk averse. Risk-neutral risk measures do not necessarily correspond to historical risk measures, although conversion formulas can be applied from asset classes where both risk-neutral and historical risk measures are available. There are many references on such techniques that are mainly used in a framework of pricing individual transactions. The reader is, a.o., referred to [66, 268, 269, 299, 300, 321, 359, 380, 431, 445]. An important remark is that the spread between firm and sovereign bonds not only depends on the expected loss component, but also on differences in taxes and systematic, economic risk factors that influence firm spreads in a similar way to equities, but do not influence government spreads. Whereas expected loss explains only 17.8% and tax differentials 36.1%, the remainder is largely explained by Fama–French<sup>38</sup> market factors [116, 163].

A recent evolution is to compare market information with external ratings. The statistical benchmarking allows rated and unrated issues and issuers to be rated based upon market prices. Such ratings are called market-implied ratings [92, 100, 336, 408].

<sup>38</sup> The Fama–French factors are the excess return on the market, the return on a portfolio of small stocks minus the return on a portfolio of large stocks, and the return on a portfolio of high minus low book-to-market stocks [177].

#### 4.4.2 LGD information

The loss given default (LGD) is the complement of the recovery rate ( $LGD = 1 - RR$ ). The LGD calculation is a process in itself. It is a very complex and time-demanding task to compute the LGD from internal recovery cash flows. These cash flows can be more complex depending on whether the default is easily cured, a recovery process is defined or the default results in liquidation with potentially high litigation costs in the bankruptcy process. For Basel II, the LGD should represent not only the book value loss, but also the economic loss realized. The economic loss includes additionally direct and indirect internal costs, etc. (ICCMCS [63] section 460). For IAS/IFRS [276], internal costs are not taken into account for the loss estimates; only the external costs are included. It is important to observe that for Basel II the economic loss is not the same as accounting loss. The economic loss also takes into account all material discount effects and material direct and indirect costs associated with collecting on the exposure.

There are different ways to compute the loss:

**Workout LGD:** The workout LGD is calculated explicitly from internal recovery and loss cash flows to compute the net present value of the loss as a percentage of the exposure at default (EAD). This requires information on the timing of the cash flows, the appropriate discount rate, allocation of costs and the timing of the end/emergence of default or workout process (Fig. 4.14b). For most LGDs, recovery cash flows will be more important than costs. Workout LGDs can be lower than zero, indicating an economic profit.

**Market LGD:** The economic loss is calculated explicitly from the market price of the defaulted facility soon after the date of default, typically around 30 days after the default (Fig. 4.14a). Ultimate recoveries defined by S&P measure the loss via market prices of restructured debt. The LGD measured is a workout LGD where the restructurings and cash-flow valuations are obtained from market prices, when no other information is available.

**Market implied LGD:** LGD values are part, together with the PD, of the credit risk component of the credit spread. The LGD information is implicitly represented in the market price and can be calculated from market prices of non-defaulted facilities. This approach assumes that one can separate the different elements of the spread: credit risk, liquidity, . . . The resulting LGD values provide a market perception of the loss risk.

The LGD depends on the market perception and sentiment. It is, a.o., useful for benchmarking purposes.

**Expected loss approach:** For retail applications, section 465 of the Basel Accord allows calculation of the LGD implicitly from the historical losses on homogeneous pools and the LGD to be inferred given the internal PD estimates. Information can be calculated for different years, counterpart and product types.

The chosen method depends on the workout practice of the bank and the data availability. Banks that sell defaulted firm obligations on the distressed bond market a few weeks after default may opt for the market LGD.

The LGD definition has to be coherent with the default definition and the EAD definition. The impact of the default definition on the LGD definition has been studied, e.g., in [367].

#### 4.4.2.1 Workout LGD

The workout LGD calculates the net present value<sup>39</sup> (NPV) of all the material cash flows (CF) at time  $\tau$  after the default event and compares it to the exposure at default (EAD):

$$\text{LGD} = 1 - \frac{\sum_i \text{NPV}(\text{CF}_i^+, \tau_i, r_i) - \sum_j \text{NPV}(\text{CF}_j^-, \tau_j, r_j)}{\text{EAD}}. \quad (4.17)$$

Positive cash flows  $\text{CF}^+$  denote (nominal) recoveries. Negative cash flows  $\text{CF}^-$  denote payments or costs involved in the workout process. The discount rate is denoted by  $r$ . The economic recoveries or payments are obtained by discounting the nominal cash flows. In some cases, the net present value of the (nominal) recoveries may exceed the EAD and LGD can become negative.

Negative LGD values involve a profit and are floored to zero. This occurs when the penalization interest and fees on the defaulted facility are higher than the value lost due to discounting.

The elements of the cash-flow discounting are the following:

**Recoveries:** Recoveries in a workout process can be cash or non-cash recoveries. Cash recoveries are easy to value. Valuation of non-cash recoveries, like repossessions and restructuring, are more complex. An appropriate evaluation is typically made on an *ad-hoc* basis.

<sup>39</sup> The net present value of a cash flow CF one year from today ( $\tau = 1$ ) amounts to  $\text{CF}/(1+r)$  where  $r$  is the interest rate applicable to the maturity and risk.

The historical tracking of non-cash recoveries can become a complex task.

In the case of a repossession, the recovery process can be considered complete at the time of repossession and one values the repossessed goods, e.g., the estimated housing price times a haircut. Alternatively, one considers the recovery complete when the cash flow is realized and the repossessed good has been sold to a third party. When a subsidiary or third party is involved in the actual selling of the goods after repossession, it is easier to apply the first method because the bank may not have a good view on all the cash flows afterwards.

In the case of a restructuring, a bond can be transformed into cash, other bond debt with different maturity and seniority and/or stocks. In complex cases, derivatives are used. A first way to evaluate the cash flow at the time of the restructuring is to use the market prices of the new products. Given the past default history, market prices on the new debt may provide too conservative an estimate. Alternatively, one can follow the new debt products and use their cash flows. When there is no subsequent default, the value of the restructured debt is most likely to be higher than the market price in the weeks after restructuring.

The assignment of a recovery cash flow to a single facility in a default with multiple facilities is not simple. It may prevent direct calculation of the facility or issue LGD.

**Costs and payments:** The Basel II definition requires taking into account all material direct and indirect costs. The measurement of direct costs is the easiest task, but is time consuming and, nevertheless, complex. Direct costs can be very case dependent such that individual measurement and storage is necessary. Examples of direct costs are lawyer and bailiff fees, fees for the appraisal of collateral, the personnel costs to follow up the recovery process . . .

Indirect costs are much more difficult to assign to individual defaulted facilities. One can use accountancy measures like activity-based cost allocation for this matter [298]. An example of an indirect cost is the cost of the office space needed by the workout department.

Apart from the split into direct/indirect costs, costs can also be split into internal/external costs and general/specific costs. Internal costs involve information investments, staff costs, organizational solutions and technologies used that affect the effectiveness and efficiency of the recovery process. The external costs are legal expenses, outsourcing costs and other external services. When using the same information system and

LGD calculations for IAS/IFRS, internal costs are not taken into account for the loss estimates; only the external costs are included. External costs are typically direct costs. General costs are related to the full workout process, while specific costs are allocated to a specific collateral or risk mitigant. Such information is useful when one wants to calculate and evaluate haircut values for collateral.

**Discount rate:** Future cash flows need to be discounted until default date to obtain the net present value. The choice of the discount rate  $r$  is still debated. From a theoretical perspective, the appropriate discount rate is the risk-appropriate rate. The use of a discount rate other than the contract rate may result into a non-zero LGD on a facility that is flagged default but manages in some way to honor all the payments on time. In hold-to-maturity portfolio modelling<sup>40</sup> techniques, the default flag has a discontinuous impact on the value of a facility. In a mark-to-market approach, a smoother dependence of the facility market price with respect to the risk profile is observed.

In most cases, there is not a lot of market information that allows the appropriate discount rate to be inferred. One distinguishes historical vs. current discount rates, single rates vs. curves and the calculation method to measure the risk premium.

A historical default rate is calculated at the time of default and is used to discount the individual cash flows. One can also define a discount rate curve at the time of default that is used to discount future cash flows. Some classical choices for the historical discount rate are

1. Contractual rate fixed at origination date (or at default);
2. Risk-free rate at default date plus a spread/margin for the risk premium;
3. Interest rate for a similar product;
4. Zero-coupon yield plus a spread at the default date.

Current discount rates are fixed on each date the LGD is calculated. They depend on the calculation date, not on the default date like historical rates. Some classical choices for the current discount rate are:

1. Average risk-free rate on the past business cycle plus a spread that reflects the risk premium, it is often indicated in regulatory guidance;
2. Spot rate at the moment of LGD calculation with risk premium.

<sup>40</sup> The concepts of hold-to-maturity and mark-to-market are explained in Chapter 5 on portfolio modelling.

The use of the current discount rate allows an easier comparison between past and current LGD values. Comparisons across portfolios with different data histories become easier. Historical discount rates reflect better the real historical loss. When the bank's decision-making process and penalization interest rates for delinquent facilities depend on the market interest rate, the use of current interest rates may not match with historical interest rates on the delayed payments. The choice of the margin or of the reference product also needs to be motivated. In [496] the average return earned by the Lehman single-B bond index was used to discount cash flows of defaulted bonds.

The choice of the interest rate for discounting the cash flows may have an important impact on the resulting LGD, especially when the recovery takes a very long time, the discount effect is important and is not compensated by the penalties (mostly in the case of non-cured defaults). Some studies indicate that the result is typically of the order of magnitude of a few per cent for LGD values around 50%. An early reference in which the impact of the discount rate has been studied is [157] and more recent studies are likely to appear soon. Because the choice of the appropriate discount rate is not explicitly defined in the Basel II Capital Accord, it is useful to assess the impact of the choice of the discount rate on the calibrated LGD parameters and evaluate to what extent conservative parameter estimates are resistant to higher discount rates.

**Timing:** The cash flows at time  $t$  after default  $t_D$  can be easily discounted using the continuous discount<sup>41</sup> rate  $r_c$ :

$$\text{NPV}(\text{CF}, \tau, r_c) = \text{CF} \exp(-r_c \tau), \quad \tau = t - t_D.$$

In practice, one often simplifies the discounting process and summarizes all cash flows of one month or quarter into one cash flow that is assumed to happen in the middle or the end of the quarter. This simplifies the database and interpretation of the cash flows. Instead of the continuous discount rate  $r_c$  one uses the quarterly discount rate  $r_{1/4}$ . Because of the discounting, a recovery has less economical value when it occurs later after default. Efficient organizations make efficient decisions and are able to reduce economic losses.

<sup>41</sup> The continuous discount rate  $r_c$  follows from the annual discount rate  $r$  using  $r_c = \log(1 + r)$ . The quarterly discount rate  $r_{1/4}$  is obtained as  $r_{1/4} = (1 + r)^{1/4} - 1$ . More details on discount rates can be found in a classical financial text book, e.g., [91, 437].

**Exposure at default:** The exposure at default (EAD) is the denominator in the LGD calculation (eqn 4.17). The measurement of the EAD has to be consistent with the EAD definition used in the organization (section 4.4.3). One EAD measure is to use the exposure at the moment of default (Fig. 4.14(c)). Other approaches measure the maximum EAD during the recovery, such that LGD is less than 100% when neglecting internal costs (Fig. 4.14(d)). The definition of the EAD automatically implies which cash flows are considered in the LGD or in the EAD.

**End of workout:** When calculating recoveries, it is important to define the end of the workout period. With firm defaults, recovery periods depend on the after-default scenario: cure, restructuring and/or liquidation. The bankruptcy of the firm and the end of the bankruptcy procedures mainly determine the emergence of default and workout processes in the case of a workout LGD for bankruptcies. If the situation is cured, the default period ends as well. In the case of a restructuring, the date of restructuring may actually determine the emergence of default. At least, the counterpart goes back to a normal situation. For the valuation of the restructured products, the workout process can still take more time when one measures the cash flows.

For retail exposures, the end of default is less straightforward to define. People that default because of unemployment may fail to recover for several years, but may recover when they finally find another job. Also sovereign and related counterpart types have the advantage that they continue to exist, except in specific cases like war.

### Illustration of workout LGD calculation.

Consider a default at year  $T$  of an exposure of €1000. The first recovery is obtained one year after default for an amount of €300, while the legal costs and internal costs are charged at the end of that year for €100. The default is closed after two years with a recovery €320 and costs of €50 during the second year. For a discount rate of 5%, the LGD becomes

$$\text{LGD} = 1 - \frac{(300 - 100/1.05) + [(320 - 50)/(1.05^2)]}{1000} = 65.5\%.$$

Note that this is a rather simple example, where all cash flows are taken into account at the year-end. When the discount rate increases from 5 to 10%, the LGD increases to 67.8%.

Apart from specific situations, the net present values of recoveries after several years will not have an important impact on the LGD measurement. In practice, it is useful to limit the recovery period to a maximum number of years after which no material impact on the average LGD is expected.

It is a complex task to write guidelines on all these choices. The principles of workout LGD calculation are illustrated in the textbox.

The LGD calculation (eqn 4.17) allows calculation of the resulting LGD, including the impact of collateral and risk mitigants. In most cases, one has detailed information to track the cash flows of the individual collateral. One can then arrange the LGD estimate such that the cash flows can be split up into the individual risk measures: total resulting LGD (LGD), unsecured LGD (LGD<sub>uns</sub>), haircuts (HC), collateral value (C) and exposure at default (EAD). Consider a default with one collateral (C). The resulting LGD value is equal to

$$\begin{aligned} \text{LGD} &= \text{LGD}_{\text{uns}} \times \left( 1 - \frac{\text{HC} \cdot \text{C}}{\text{EAD}} \right) \\ &= \frac{\text{EAD} - \text{HC} \cdot \text{C} - \sum(\text{NPV}(\text{CF}_f^+, r) - \text{NPV}(\text{CF}_f^-, r))}{\text{EAD} - \text{HC} \cdot \text{C}} \\ &\quad \times \frac{\text{EAD} - \sum(\text{NPV}(\text{CF}_c^+, r) - \text{NPV}(\text{CF}_c^-, r))}{\text{EAD}}, \end{aligned}$$

with

$$\begin{aligned} \text{LGD}_{\text{uns}} &= \frac{\text{EAD} - \text{HC} \cdot \text{C} - \sum(\text{NPV}(\text{CF}_f^+, r) - \text{NPV}(\text{CF}_f^-, r))}{\text{EAD} - \text{HC} \cdot \text{C}} \\ \text{HC} &= \frac{\sum(\text{NPV}(\text{CF}_c^+, r) - \text{NPV}(\text{CF}_c^-, r))}{\text{C}}. \end{aligned}$$

The cash flows related to the unsecured part of the facility are denoted by  $\text{CF}_f$ . The subscript c indicates that the cash flows are coming from the collateral  $\text{CF}_c$ . As it appears from the formula, collateral can have a strong impact on the resulting LGD as it reduces the part of the exposure that needs to be recovered from the counterpart itself. Asset types that are pledged as collateral are financial assets (bonds, stocks, cash, . . .), real estate in mortgages, tangible and intangible firm assets, . . . The cash flows of the collateral allow the haircuts to be identified. Haircut factors reduce the value of the collateral to a realistic value that will be realized by the bank upon default. The haircut factor depends on various aspects. For financial collateral, currency and maturity mismatches and holding costs are described in [63]. Apart from



such effects, haircuts depend strongly on the collateral type. The estimation of haircut factors needs to take into account saturation effects in the case of zero loss due to strong overcollateralization.

For defaults with multiple facilities and much collateral that is not allocated to a specific facility, the allocation of the recovery and payment cash flows becomes a complex and difficult task. When there are products with different discount rates (e.g., different risk types), the total resulting loss related to the default can depend on the allocation. At least, the allocation has to be consistent with the calculation of the risk weighted assets, in which there remains, nevertheless, some flexibility and room for regulatory arbitrage [70, 228].

Additional complexities in the whole estimation process occur when guarantors have the legal right to pursue the borrower for the money they lost in the case of default. This priority rule may impact the recovery of the unsecured part [158, 319].

### 4.4.2.2 Market LGD

The market LGD measures the economic loss from the market perception. After the default event, bonds in the US are still traded and the price compared to the face value. Typically, nominal recoveries are defined by evaluating the price of the defaulted instrument 30 days after the default date. Defaulted debt can have a thin trading. It may not have a market price exactly 30 days after default or its price can be very volatile. The precise 30 days after default may therefore not fully reflect the recovery potential and some institutions prefer to measure the average price in a period of 10 to 20 trading days one month after default.

The market price LGD assumes that the market is efficient and that, on average, the market price provides a correct value for the defaulted instruments. Of course, there is still a lot of uncertainty about the actual recovery of the defaulted instrument and the market participants will require a margin according to their risk/return investment strategy and general risk appetite. In [496], it was concluded that the workout recoveries and market price recoveries are on average not very different when workout recoveries are discounted with a sufficiently high discount rate (BB-rated bonds). Other studies report different results [453]. Nevertheless, distributions of market price and workout LGDs will be different. Market prices cannot exhibit a point mass at 100% LGD because then the defaulted instrument would not be traded. Higher LGD values do not occur. Negative market price LGD values that represent a net gain are also less likely to be observed.

The above definition of market price LGD is the most commonly used. The LGD can also be measured later on in the default process when there is more information on the actual default type<sup>42</sup> and the corresponding loss is available. In [453], one computes the settlement price LGD from market information by using the market value of non-cash settlements shortly after emergence of default. All cash and market-valued non-cash recoveries are discounted to obtain the resulting economic loss. For new bonds in the restructuring process, there is also the option to discount the resulting cash flow stream of the bond. In the case of no subsequent default, the NPV will generally be higher than the market price after emergence. The latter approach has the disadvantage that the workout process becomes lengthy. In [496] the difference between bond price after default and close to emergence was found to be similar when taking into account the discount effect of a single-B rate.

The evaluation of the LGD after emergence has the advantage that the market pricing is closer to the idea of a workout LGD, but has the disadvantage that internal and external costs during the default/bankruptcy process are not taken into account in the market prices. For large firms, these costs have been reported to vary between 0.5% and 2%, which is not a main concern. These costs tend to increase to about 6% for smaller tickets, e.g., in the leasing business. When doing internal LGD estimations, it is possible to include such types of costs.

#### 4.4.2.3 Market-implied LGD

Bond, equity and swap market prices include a component that reflects the credit risk. The techniques to estimate the credit risk parameters involve the assumption of a risk-neutral investor as explained in section 4.4.1.6. In some approaches the PD and LGD risk-neutral measures are typically inferred together such that a split up between PD and LGD is required, e.g., by using additional information from external ratings or by comparing multiple facilities of the same issuer.

#### 4.4.2.4 Expected loss approach

For retail exposures, one probably has estimates on the expected loss. For a homogeneous pool, the loss given default can then be estimated via reverse engineering of the formula:  $\text{expected loss} = \text{probability of default} \times \text{loss}$

<sup>42</sup> For example, cure, restructuring with distressed exchange, bankruptcy and liquidation.

given default. In most cases, it is easier to estimate the PD than the LGD, such that the expected loss approach is a useful technique to estimate the LGD for retail exposures.

#### 4.4.2.5 Recovery ratings

Stimulated by the importance of loss given default and recovery estimates in the Basel II Accord [63], the rating agencies reacted and differentiated their ratings towards issuer default risk and issue recovery risk. The recovery rating scales of the rating agencies have been discussed in Table 3.5. Each recovery rating gives a range of the expected recovery rate. The recovery ratings have disjunct recovery intervals.

The use of external recovery ratings is useful for benchmarking and to obtain additional observations for low default portfolio's. A disadvantage is that recovery ratings do not yet have sufficient data history. Average actual recovery values are still to be reported.

#### 4.4.3 EAD information

The estimation of the exposure at default (EAD) is directly connected with the LGD definition and estimation. The combination of  $EAD \times LGD$  defines the economic loss in case of default. The two main approaches to define the EAD are:

1. The EAD reflects the exposure at default in its literal sense. It reflects the total exposure at risk on the very moment of default (Fig. 4.14(c)). The EAD is the net present value of all current and future amounts due by the defaulted counterpart as defined by the product on which he defaults. In this case, additional drawings are considered as a cost and enter in the LGD.
2. The EAD reflects an exposure during the default process. Typically, one defines the EAD during the default process as the maximum observed EAD (Fig. 4.14(d)). This EAD definition also takes into account drawings after default. These additional credits are given by the bank with the perspective of a cure or reduced loss.

The first approach has the advantage that the EAD is fixed in time and the length of the recovery process only impacts the LGD calculation. It has the disadvantage that additional drawings may cause LGD values above 100%. The second approach has the advantage that the LGD will be almost surely lower than 100%, except when one would make more costs than one

actually recovers in terms of the net present value. It has the disadvantage that neither the LGD, nor the EAD are fixed at the time of default. Both parameters depend on the length of the recovery process.

The EAD is measured for different products and different portfolios. A general rule for EAD measurement is that the measurement is consistent with the default definition and the LGD measurement. The latter implies, e.g., that collateral is generally taken into account in the LGD calculation and not for the calculation of the EAD. Netting agreements are discussed in section 4.4.3.3. Because EAD calculations are often specified by regulators, readers are advised to contact their local supervisors to verify calculation details.

The EAD calculation is preferably consistent with the IFRS accounting data, where in most cases the calculation is based upon amortized costs. It includes accrued interests and unpaid amounts on interests and capital and can be calculated net of specific provisions. The main calculation methods are:

**Amortized cost:** The amortized cost is the amount at which the asset was measured initially (acquisition cost), minus principal payments, plus or minus corrections for premiums or discounts net of amortization (difference between initial amount and maturity amount), plus or minus deferred acquisition costs net of commissions income, plus accrued interest and minus any write-downs and provisions.

This accounting method is typically used for loans and advances from banks and customers, and for hold-to-maturity portfolios.

**Fair value:** The fair value is an estimate of the market value of the instrument in the absence of an actual exchange. The estimate is required to be an objective and unbiased price between knowledgeable, unrelated willing parties.

The fair value is determined from the market price of identical products, from the market price of similar products with corrections for the differences and from valuation techniques or pricing tools. The latter approach uses mathematical models to determine the price based upon internal and external information and is applicable when the first two are not possible. The fair value of a bond can be obtained using the discounted cash flow methodology, discounted at an interest rate valid for a similar product.

Fair value accounting is typically applied for trading portfolios and assets that are available for sale.

Dedicated rules are typically defined for specific products such as leases, receivables, equity, derivatives and hedges. For leases, the exposure at default is calculated as the discounted minimum cash flows from the lease, with a special treatment for the residual value. For receivables, regulatory capital is required to cover dilution risk (as discussed in Chapter 6), which is deducted from the exposure to avoid double regulatory accounting. Equity exposures can be calculated net of any depreciations or specific impairment. For derivatives and hedges, the replacement cost at default can sometimes be easily measured or is approximated as the fair value plus a proportion of the nominal amount. Note that there exist specific rules for each of these products, some of which are summarized in section 4.4.3.3 for derivatives.

#### 4.4.3.1 Credit conversion factor (CCF)

The EAD measure  $E(t^*)$  is typically expressed in terms of the current exposure  $E(t)$  and the current credit limit  $L(t)$  of the facility. In most cases the credit conversion factor<sup>43</sup> (CCF) is defined as the part of the remaining limit “today” ( $t$ ) that is drawn upon the measurement of the EAD ( $t^*$ )

$$\begin{aligned} \text{EAD} &= E(t^*) = E(t) + \text{CCF} \times (L(t) - E(t)) \\ \text{CCF} &= \frac{\text{EAD} - E(t)}{L(t) - E(t)}, \end{aligned} \quad (4.18)$$

where it is assumed that  $L(t) > E(t)$ . The time index ( $t$ ) denotes the moment at which the CCF is measured. It is the reference date towards which one defines the EAD. The EAD itself is measured on the time index  $t^*$  that denotes either the default date or the day of maximum exposure. The CCF converts exposure risk of the nowadays undrawn amount  $(L(t) - E(t))$  to an equivalent or average amount of virtual credit used for the internal risk calculations. The undrawn amount  $(L(t) - E(t))$  is not reported on the balance sheet, it is called the off-balance sheet exposure. It still represents a risk because it can be drawn between  $t$  and  $t^*$ . In some applications, one expresses the exposure  $E(t^*)$  as a function of the full limit  $L(t)$  in terms of the loan equivalent

<sup>43</sup> The name credit conversion factor is used in the Basel II Capital Accord. The term conversion factor is used in the Capital Requirement Directive. In the US implementation drafts, one uses the name loan equivalent factor. Many different names for the same concept are typical in a new domain.

factor (LEQ)

$$\begin{aligned} \text{EAD} &= E(t^*) = \text{LEQ} \times L(t) \\ \text{LEQ} &= \frac{\text{EAD}}{L(t)}. \end{aligned} \quad (4.19)$$

It is important to use consistently eqn 4.18 or eqn 4.19. The regulatory framework imposes that the EAD cannot be lower than the current exposure, which implies that  $\text{CCF} \geq 0$  and  $\text{LEQ} \geq E(t)/L(t)$ .

#### 4.4.3.2 EAD & CCF Measurement

Besides the definition of  $t^*$  at the moment of default or at the moment of maximum exposure, there also remains the question of the correct moment  $t$  on which the EAD/CCF/LEQ<sup>44</sup> is measured [366]:

**Fixed time horizon:** The measurement date  $t$  of the CCF is a fixed number of days  $T$ , e.g., one year before the EAD measurement date  $t^*$ . The choice of the time horizon has to be in line with the definition of the portfolio risk horizon definition. For Basel II, a one-year horizon is a natural choice. An advantage is that the fixed horizon provides a uniform CCF definition and that the measurement dates are dispersed over the year.

Problems with this fixed time horizon occur when the default occurs on very young facilities with age less than  $T$ . One can solve this by taking the maximum time possible capped by  $T$  in such cases. It is less consistent with the cohort method of PD measurement.

**Cohort method:** The cohort method measures the CCF at fixed time moments  $t \in \{t_0, t_0 + \Delta, t_0 + 2\Delta, \dots\}$ . The measurement time  $t$  is the largest possible before the EAD measurement date  $t^*$  or the default date. The advantage is that one can follow the same approach as for the PD measurement, where one typically chooses  $t_0$  at new year and takes a cohort length  $\Delta$  of one year. Of course, these choices can be debated. The CCF/LEQ measured in this way assumes that the facility can default at any moment during the following year.

Disadvantages are that the reference dates for the measurement are concentrated and that the corresponding CCF can be less homogeneous. This may cause a bias, e.g., when the bank defines its limits afterwards or changes them continuously.

<sup>44</sup> In the remainder of this section, only the CCF is used for the convenience of notation.

**Variable time horizon:** The variable time horizon method measures the CCF/LEQ at several dates  $t$  before  $t^*$  (or the default date when  $t^*$  measures the maximum EAD). For example, one could measure the CCF every month in the year prior to default. This procedure allows analysis of the impact of the choices made in the previous periods. Both seasonality and time to default impact can be analyzed.

A disadvantage is that the observations are no longer independent, which makes the statistical analysis more complex. It requires a more complex infrastructure to store all the data. The coherence with the PD estimation is reduced.

The method that is eventually chosen, has to be decided by the management. The choice depends, a.o., on how active the limits are managed. Based upon the coherence with PD measurement, the cohort method is an attractive option.

#### 4.4.3.3 Counterpart credit risk

Privately negotiated financial contracts are subject to counterpart credit risk: the counterpart of the contract may default prior to the expiration date. Examples of such contracts are over-the-counter (OTC) derivatives and security financing transactions (SFT). In exchange-traded derivatives, the exchange guarantees the cash flows promised by the derivative to the counterparts and there is no counterpart credit risk. Like other forms of credit risk, there can be a loss in case the counterpart or obligor defaults. Specific to counterpart credit risk are two additional features:

**Uncertain exposure:** In the case of default of the counterpart, the other counterpart needs to close the position with the defaulting counterpart and enter into a similar contract with another counterpart to maintain the same position. The exposure at default is the replacement cost of the defaulting contract. The replacement cost depends on the market value of the contract at default:

**Positive contract value:** The current contract value specifies that the bank receives a positive cash flow from the counterpart. However, because of the default of the counterpart, the position is closed, but nothing is received from the defaulting counterpart. In order to maintain the market position, one enters into a similar contract with another counterpart that one pays the market value of the contract. The net loss for the bank is the market value of the contract.

**Negative contract value:** The current contract value specifies that the bank needs to pay the counterpart. The position is closed and the bank pays the defaulting counterpart or its claim holders. To maintain the bank's market position, one enters into a similar contract with another counterpart that pays the bank the current market value of the contract. Neglecting transaction costs, the net loss is zero.

Because the contract value changes unpredictably with changing market conditions, the exposure at default is not known beforehand. The net loss varies between zero and the maximum contract value.

**Bilateral risk:** Because the contract value is uncertain and can change sign, both counterparts have the risk that the counterpart defaults when the contract value is positive. Both counterparts in the contract have an incentive to reduce the exposure risk.

In general, there are more contracts between the counterparts. The maximum loss is the sum of all contract-level credit exposures.

Note that credit risk is a side aspect of the trading book contracts, which are mainly used to take or hedge market risk positions. An important technique to reduce counterpart credit risk exposure are netting agreements. A netting agreement is a legally binding contract that allows aggregation of transactions between counterparts in the event of default. Contracts with positive value are offset against contracts with negative value and only the net value is paid/received in the case of default. The exposure at default of all contracts in the netting set is the positive net portfolio value or zero otherwise.

The netting set counterpart credit exposure can be further reduced by margin agreements. Such agreements specify that the counterpart with a negative netting set value has to offset the corresponding positive netting set value of the counterpart by pledging collateral when the net value exceeds a specified threshold. Both counterparts periodically evaluate the market value of their contracts and pledge more or less collateral. Margining agreements reduce the exposure risk to the margin threshold.

There exist different measures of the exposure risk:

**Current exposure (CE):** the market value of a contract or a portfolio of transactions within a netting set that would be lost in the case of default without recoveries. The current exposure is also known as the replacement cost.

**Peak exposure (PE):** a high percentile (95th or 99th) of the distribution of exposures at a given particular future date up to the longest maturity date



of transactions in the netting set. For small, non-diversified netting sets, the peak exposure can be much higher than the expected exposure. It is used in limit setting.

**Expected exposure (EE):** the mean value of the distribution of exposures at a given particular future date  $t_k$  up to the longest maturity date of transactions in the netting set. Because of amortization, the EE decreases towards the longest maturity date in the netting set.

**Expected positive exposure (EPE):** is the time-weighted average of the expected exposures where the weights are the proportion that an individual expected exposure represents of the entire time interval:

$$\text{EPE} = \sum_{t=1}^{\min(1y, \text{mat.})} \text{EE}_k \times \frac{\Delta t_k}{T},$$

with  $\Delta t_k = t_k - t_{k-1}$  and  $T = \min(1y, \text{mat.})$ . For capital calculations or effective expected positive exposure, the time interval is the lowest of one year and the longest maturity in the netting set.

**Effective expected exposure (Eff. EE):** is the maximum expected exposure that occurs at a given date or in the period prior to it. It is the highest expected exposure that can occur up to the given date. When  $\text{EE}_0$  is equal to the current exposure, the Eff. EE is recursively defined by

$$\text{Eff. EE}_k = \max(\text{Eff. EE}_{k-1}, \text{EE}_k).$$

The non-decreasing aspect of the Eff. EE is motivated by roll-over risk: with short-term contracts maturing, the expected exposure decreases, but these contracts are likely to be replaced by new contracts. This risk is known as roll-over risk.

**Effective expected positive exposure (Eff. EPE):** is the time-weighted average of the effective expected exposure over the first year or the longest maturity in the netting set:

$$\text{Eff. EPE} = \sum_{t=1}^{\min(1y, \text{mat.})} \text{Eff. EE}_k \times \frac{\Delta t_k}{T},$$

with  $\Delta t_k$  defined in the EPE calculation. The effective expected positive exposure is generally considered as the most appropriate measure for counterparty credit risk in the trading book.

The exposure measures are illustrated in Fig. 4.18 for the case of two call options with maturity 6 and 18 months with current exposure equal to €1.

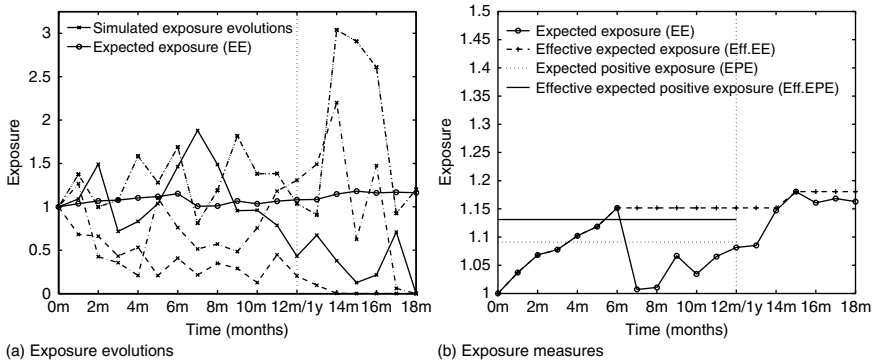

**Fig. 4.18** Counterpart credit risk exposure evolutions are depicted in the left pane for the case of two call options with maturity 6 and 18 months. Observe that the exposure levels may fluctuate significantly due to market price fluctuations. The level of these fluctuations depends on the diversification of the contracts in the netting set. For a current exposure (CE) of €1, the exposure measures expected exposure (EE), effective expected exposure (Eff. EE), expected positive exposure (EPE) and effective expected positive exposure (Eff. EPE) are reported in the right pane.

The exposures are simulated every month ( $\Delta t = 1m$ ), each expected exposure is weighted with  $\Delta t/T = 1/12$  with  $T = \min(12, 18)$ . On the graph, the non-decreasing condition on the effective expected positive exposure is clearly seen. With margining agreements, the exposure risk is reduced up to about the margin threshold.

Note that the counterpart credit exposure risk is typically measured by simulation techniques, it is not measured on defaulted counterparts. It assumes implicitly that the exposure risk is not correlated with the default risk of the counterpart. It may occur that some counterparts may get into financial distress because of adverse movements in contract values. To account for wrong risk, a multiplication factor for the effective EPE ranging from 1.1 to 1.2 has been reported [401].

A typical approach to measure exposure risk consists of the following steps:

**Scenario generation:** Random scenarios of risk factors are generated to simulate possible future market evolutions. One can choose to generate scenarios independent of the dates or generate complete time paths of subsequent market evolutions. The first option is the simplest and most suitable for simple products. The second type of scenarios are more complex but more suitable for complex products with path-dependent price characteristics (e.g., barrier options).

**Instrument valuation:** The generated simulations are used to evaluate the market price and exposure of the different contracts. For the price evaluation, typically simplified models are used to allow fast computation.

**Aggregation:** For each generated scenario, the evaluated values of all the contracts in the netting set are aggregated. The resulting exposure is the highest of zero and the netting set value. By calculating exposures at different time horizons, the effective positive exposure is calculated.

In the case of margined portfolios, the exposure risk is reduced but the modelling becomes more complex. On top of the margin threshold, there is an additional risk that the prices move in adverse directions during the period that the risk is reheded by collateral. This period is called the margin period of risk and consists of the monitoring frequency time (margin call period) and the time necessary to pledge the collateral by/with the counterpart (margin cure period). This system requires an additional simulation complexity: contract prices and collateral value need to be simulated. There also exist simplified, quasianalytic expressions when the mark-to-market value of a portfolio follows a random walk with Gaussian increments [401].

More information on the evolution of market risk instruments and their pricing is available from, e.g., [10, 78, 95, 260, 426]. Specific discussions on credit counterpart risk can be found in [166, 401] and in the Basel II documents [62, 63, 247]. Regulations on Basel II exposure measures for counterpart credit risk are discussed in Chapter 6.

### 4.4.4 Explanatory data

Explanatory variables are used for empirical model construction and model use. The quality of the model inputs, independent variables or explanatory variables is often the most important driver of model performance.

The definition of explanatory variables for model design is an art that needs to be done in close co-operation between financial and statistical experts. It is useful to consult the literature to define a large number (typically more than 20) candidate variables before constructing a model. Depending on the application, explanatory variables are defined on the issuer or issue level. When required, issuer variables can be obtained by aggregating issue variables, issue variables by allocating issuer variables.

Issuer data is calculated at the aggregated level across all issues of the issuer. Within a regulatory framework, default risk assessments are assigned at the counterpart level (except for retail).

#### 4.4.4.1 Quantitative and qualitative data

Explanatory variable types can be quantitative or qualitative in nature. Some qualitative variables, like management perception, may have a subjective interpretation. Many external rating assessments are at least partially based upon expert assessment. It is plausible to assume that qualitative indicators like quality of management, regulatory supervision, and financial flexibility may also impact the rating [220, 244].

In order to apply and use variables and inputs, a clear definition should be available in the model documentation. The inputs have to be defined in a clear and sound way with unique interpretation. Quantitative and objective variables are preferred above judgmental input variables where possible and with the same predictive power. Judgmental variables may be subject to the same problems as judgmental expert ratings. Of course, the information needed to compute the quantitative variables needs to be available. Within the Basel II regulatory framework, it is preferred to use objective risk assessments, while human expert analysis is, nevertheless, conceived as important on top of the quantitative model rating.

#### Quantitative data

Quantitative inputs are obtained numerically in an objective way. Typical examples of quantitative inputs are financial ratios, but also macroeconomic variables and market information (equity prices, volatility, spreads) are quantitative inputs (e.g., used in structural or statistical models).

An important type of financial variables are accountancy information variables, examples of which are commonly used for risk assessment. Debt information and debt structure are not only important for default risk assessment, but also for loss risk. In some studies, the loss risk is determined by both absolute and relative seniority, where the latter indicates the proportion of more senior debt above the assessed issue. Other financial variables are determined by external information sources like the IMF, the World Bank, rating agencies, credit bureaus or data-pooling initiatives. Financial variables are also obtained from internal bank data sources. One variable that is often used is the length of the customer relationship. For retail scoring, behavioral systems are based upon internal accounts information. Tables 4.3–4.8 provide an overview of financial variables for various counterpart types.

Accountancy variables are typically split into flow and stock variables. Stock variables like gross domestic product, debt, equity or total assets sum up or integrate past cash flows or investments. Cash flows are typically

flow variables (e.g., revenues, net revenues, expenses) and are more volatile than stock variables. Stock variables are less volatile than flow variables. The latter may lead to rather volatile assessments. Flow variables can be stabilized by defining averages as explained in section 4.4.4.3.

Market data includes several types of information. The most frequently used information is equity information, which exists only for stocklisted variables. Based on the equity information, one can derive distance to default measures and other ratios. Such information can be used on a stand-alone basis (e.g., Merton-type models) or in combination with other ratio types (see, e.g., [28, 197, 450]). Besides equity information, spreads of the specific debt issues also yield information on the market perception of the relative creditworthiness of the counterparts. The higher the spread, the more risky is the specific debt issue. Of course, spreads are also determined by many factors other than the credit risk component, like liquidity, . . . One possibility is to compare the default spread with a benchmark default spread of a sector/country pool of rated issues. Alternatively, one can also use derivative information (like credit default swaps), where the premium paid reflects the perceived risk of the counterpart. The main advantage of the use of equity, debt or derivative market data is that they serve as an early warning of possible difficulties. The data are much faster and more frequently updated than accountancy information. On the other hand, one should be aware that market indicators reflect the current market perception on the counterpart, which may be influenced by a lot of objective but also subjective criteria. Such subjective criteria may also lead to overreactive market behavior. Generally, market information is known to be more discriminant in the short term than accountancy information, while accountancy information is known to be more discriminant in medium to the long term [28, 133, 197, 450].

### **Qualitative data**

Qualitative inputs are non-quantitative inputs. One has non-judgmental and judgmental inputs. Non-judgmental or objective variables include clearly defined values or indicators defined on objective criteria, e.g., male/female, education level, profession, geographic region and industry sector. The use of objective indicators is especially interesting when constructing a joint scoring function for multiple categories of counterparts, at the same time allowing some specification towards the different categories. Given that objective criteria are used, these variables are defined in a unique manner for almost all cases. External ratings are assigned in an expert way, but can be conceived as sufficiently objective for internal use in credit assignment.

Judgmental variables have to be completed by human expertise and contain a subjective element. Judgmental data include economic outlook, market environment, assessment of management quality, quality of disclosure. For default risk, past delinquency flags are important predictors. In order to limit the perceived subjectivity of the judgmental indicator, one has to clearly define and document the meaning of the different values the subjective indicator can take.

There are different types of qualitative indicators. Binary indicators can take two values, typically yes/no answers. Ordinal multiple indicators can take more values, but in increasing/decreasing scale, e.g., small, medium, large. Other multiple class indicators are expressed on a non-ordinal scale, e.g., geographic regions Africa, Asia, Europe, North-America, South-America and Oceania.

#### 4.4.4.2 Absolute and relative information

Accounting information can be used in absolute values and ratios (e.g., total assets and return on total assets), or in relative values where the values are compared to the mean or median of a benchmark population. Absolute values are easy to apply and calculate. Relative values are more difficult to define, apply and calculate, but may have more information value [395].

In a global model for firms, one may, e.g., compare return on total assets to the sector average. Such a relative measure indicates how good a firm performs compared to its sector and competitors. It can be more relevant to compare high-tech firms in microelectronics with the performance of the microelectronics sector, and an energy producer with the energy sector, instead of using the return on assets of both firms in the same way in the same rating model.

Disadvantages of relative variables are the more complex variable definition and calculation, as well as the difficulty of incorporating the effect of a global stratum that becomes distressed. Indeed, one needs to find homogeneous strata that are relevant to define peer groups for comparison. Clear definitions need to be made to allocate each counterpart to one of the strata. All these choices need to be statistically and financially relevant.

Although more complex, relative ratios are often financially meaningful and also allow development of global models that are valid for multiple homogeneous groups with similar but not exactly equal characteristics. The use of such global models has advantages in terms of data requirements to estimate the model upon, model development, maintenance and

management and consistency of rating assignment across different sectors. The disadvantage of one global stratum in distress can be handled by combining both relative and absolute ratios (possibly expressing different ratio types) in the same model.

#### 4.4.4.3 Time aspects

##### Averages and trends

Ratios and financial indicators evolve in time. Some figures tend to be quite volatile and evolve quickly over time. Others are stable and evolve smoothly. Accounting information provides a yearly snapshot of the counterpart's behavior that can be extended with quarter or semester results. In general, financial information provides a snapshot of the counterpart that will be used in a short- or long-term risk assessment. It is obvious that a sequence of snapshots provides more detailed information for the risk assessment of the counterpart than only the most recent picture. A sequence of snapshots creates a movie of the recent evolution of the counterpart to make a more in-depth risk assessment.

The ratio<sup>45</sup> history  $\dots, r_{t-6}, r_{t-5}, r_{t-4}, r_{t-3}, r_{t-2}, r_{t-1}, r_t, \dots$  can be used in different ways:

**Most recent value:** The most recent value  $r_t$  is the most recent observation that is available for the risk analysis. When the  $r_t$  value is missing, one uses  $r_{t-1}$ , and so on. Intuitively, the most recent information is very useful for risk analysis as it reflects the present status of the counterpart. On the other hand, the most recent value may be influenced by one-time, exceptional events and give a perturbed picture of the counterpart.

**Past value:** The past value  $r_{t-T}$  uses a value in the past to predict a default in the near/far future. In most cases, the use of the most recent value or an average value is preferred from a financial perspective.

**Moving-average value:** The moving average value  $r_{av}$  is the average of a relevant period of the most recent observations:

$$r_{av} = \frac{r_t + r_{t-1} + \dots + r_{t-T+1}}{T}.$$

<sup>45</sup> Notice that instead of ratios, one can also use financial information in general that can be used in a ratio definition afterwards. For example, in a ratio  $r = x/y$  where the numerator  $x$  is a stock variable and the denominator  $y$  is a flow variable, one can first calculate the average  $y_{av}$  of the flow variable to obtain a more stable ratio  $r' = x/y_{av}$ .

The period  $T$  on which the average is computed varies from 2 years to the full economic cycle. The longer the period, the more historical data is taken into account. It also requires a longer data history to compute the average, which may be a problem in the case of data limitations. In practice, data limitations will limit the choice of a long period  $T$  on which the data can be calculated, as illustrated in Fig. 4.19b. Within such data limitations, one can define multiple time periods  $T$  and select the most predictive one.

A (conceptual) disadvantage of the above average formula is that past and recent information is equally important. Intuitively, more recent years are more important in the risk analysis. Therefore, one can also use weighted

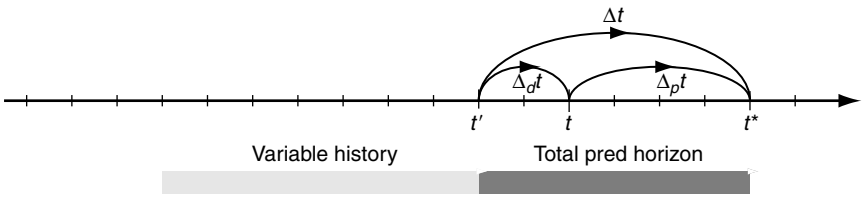

(a) Total prediction horizon and variable history

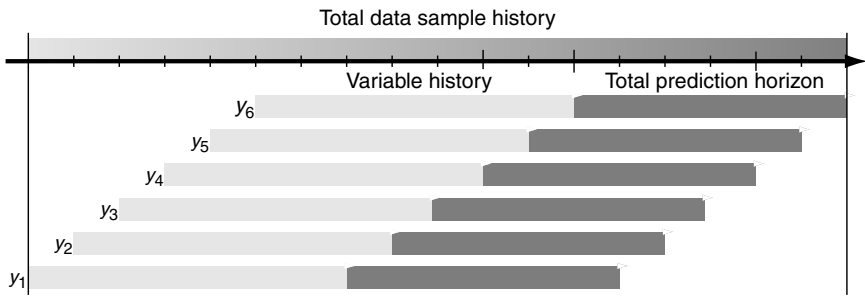

(b) Total data sample history

**Fig. 4.19** Variable history, prediction horizon and data sample history. (a) The data of  $t'$  becomes available with some time delay at time  $t$  when the risk assessment up to time  $t^*$  is made. The implicit prediction horizon  $\Delta t$  consists of the horizon of the assessment  $\Delta_{pt}$  and the data delivery delay  $\Delta_{dt}$ . A predictive variable can be based upon most recent information (typically for a stock variable), but also on the average or trend over the last periods (typically for a flow variable, an average of 7 periods in the graph). The time span of the information on which the variable is based is called the variable history. (b) For a model that covers 6 periods  $y_1, \dots, y_6$ , the total data history depends on the length of the prediction horizon and the variable history. For a given total data history on which data is available, one needs to balance the length of the prediction horizon, the length of the variable history and the number of periods in the data estimation (6 in the above example). Basel II requires a minimum of 5 to 7 years for firm PD and LGD estimates, respectively.



averages

$$r_{\text{Wav}} = \frac{w_t r_t + w_{t-1} r_{t-1} + \dots + w_{r-T+1} r_{t-T+1}}{w_t + w_{t-1} + \dots + w_{r-T+1}},$$

with typically decreasing weights  $w_t \geq w_{t-1} \geq \dots \geq w_{r-T+1} \in \mathbb{R}$ . The weights can be inferred from data, which can be computationally very demanding if one wants to optimize them within a multivariate setup for all candidate ratios. Some reference weighted moving averages are

$$\begin{aligned} r_{\text{Wav}} &= \frac{Tr_t + (T-1)r_{t-1} + \dots + 1r_{t-T+1}}{T + (T-1) + \dots + 1}, \\ r_{\text{Wav}} &= \frac{e^{-\lambda 0} r_t + e^{-\lambda 1} r_{t-1} + \dots + e^{-\lambda(T-1)}}{e^{-\lambda 0} + e^{-\lambda 1} + \dots + e^{-\lambda(T-1)}}. \end{aligned} \quad (4.20)$$

The first formula is known as the (plain-vanilla) weighted moving average. The second formula puts exponentially decreasing weight factors  $e^{-\lambda i}$  on past data, with  $w_{r-T+1} \rightarrow 0$  for  $T \rightarrow \infty$ . The decay parameter or forgetting factor  $\lambda \geq 0$  can be tuned to maximize discrimination, either per individual ratio or for all/selected candidate ratios together, thereby reducing the computational burden. It can also be chosen as a fixed percentage, e.g.,  $\lambda = 10\%$  or one can impose a low value  $\kappa$  at the end of the period, such that  $e^{-\lambda(T-1)} = \kappa$ . A committee of financial experts are well placed to give an indicative range for the forgetting factor. The inverse  $1/\lambda$  denotes the reference time period on which the impact of an observation is forgotten. This moving average is called an exponentially moving average or an exponentially weighted moving average. Such exponentially moving averages are also known as smoothing.

**Trends:** Trends indicate the evolution of the counterpart in the past. The growth of the key financial variables and ratios allows analysis of whether profitability, liquidity, capitalization, revenues, cost, debt values or other ratios have been increasing or decreasing in the past. The past evolution may indicate the strengths or weaknesses that may evolve in a similar way in the future. The trend can be expressed in absolute numbers

$$r_{\text{atr}} = \frac{r_t - r_{t-T+1}}{T},$$

or relative with respect to the original value

$$r_{\text{itr}} = \frac{r_t - r_{t-T+1}}{Tr_{t-T+1}}.$$

Absolute trends are useful for ratios, while relative trends can be used for both size variables and ratios. For size variables, the distribution of absolute trends may need to be corrected. Relative trends of size variables are growth indicators, e.g., total assets growth. Relative trends have the disadvantage that the definition may imply problems with sound ratio interpretation and fat-tailed distributions in the case when the denominator becomes close to zero or even when it can change its sign. The issue of correct ratio definition is further elaborated in the next section. Statistical aspects of correct ratio definition will be discussed in Book II. The time horizon  $T$  to consider can be determined by statistical inference or expert judgement within data history limits. Other definitions of trends can also be applied, e.g., one may use compounded one-year trends possibly with a higher weight on more recent evolutions.

Observe that more complex ratios can also be defined, by taking averages/trends/most recent values for the denominator and different time aspects for the numerator. Consider, e.g., a ratio net earnings/savings compared to debt. As debt is a stock variable, it is stable and it is intuitive to use only the most recent available value. Net earnings or savings is a more volatile figure and it can be interesting to average it out over a couple of observations using a simple or weighted moving average. Often, the variable history  $T$  is limited by practical considerations like data availability and a sufficient number of training periods, as illustrated in Fig. 4.19b. For a given total data history length, the longer the variable history  $T$ , the smaller is the number of years/periods that are available for model estimation.

### Data delay and prediction horizon

The risk assessment needs to be predictive, not descriptive. The model serves to make a prediction of risk, not to explain after the default event why the default occurred or why the loss/exposure was high. In predictive models, the risk assessment is forward looking. Data of today  $t$  are used to assess the risk up to or at time  $t^* \geq t$ . In the case of (specific) provisioning when a default happened, the LGD and EAD assessment horizon is very short. In most circumstances the prediction horizon  $\Delta_p t = t^* - t$  is determined by the remaining maturity of the issue or put equal to 1 year for the issuer in performance assessments.

The explicit prediction horizon  $\Delta_p t = t^* - t$  measures the time between the risk assessment  $t$  and the target date  $t^*$  the assessment covers. The larger the time horizon, the more difficult the assessment is and the less representative

is the current data for the future condition of the issuer or issue. When using external data, the risk assessment  $t$  may not be based upon financial data  $r_t$  because this data is only available with a data delivery delay  $\Delta_d t$ . Accountancy data of the year 2000 only becomes available during the year 2001. In practice, the data delivery delay  $\Delta_d t = t' - t$  has to be taken into account when constructing the model because it may have a non-negligible impact on the quality of the assessment. This data delay takes into account all possible delays until the data is used for risk assessment: reporting, transportation, waiting times . . . The data  $r_{t'}$  observed at  $t'$  itself can be composed of data observed at  $t'$  and before, as explained in the previous section. A prediction is made up to  $t^*$  such that the implicit prediction horizon between data and target date for the assessment becomes equal to  $t^* - t' = \Delta t = \Delta_d t + \Delta_p t$ . The different data delays are visualized in Fig. 4.19a. Data delays are typically small for market data and internal data, but can be longer for firm data and for macroeconomic data.

#### 4.4.4.4 Correct variable definition

When variables are defined, a correct interpretation and valid range needs to be defined. When variables go outside the valid range or go outside their reasonable range, corrective actions are applied to limit the impact on the resulting score. Apart from extreme high and low values, one needs to identify valid ranges for each variable component. A negative return on equity can be due to a loss or due to negative equity. Both negative equity and a loss (negative return) can be interpreted as too optimistic when only the ratio value is optimistic. A main source of variable problems is due to denominators in the formula that may change sign. More details on statistical aspects of correct ratio definitions are given in Book II.

Accountancy data needs to be analyzed consistently and coherently. Financial statements are subject to local accountancy practices and leave room for interpretability,<sup>46</sup> therefore it is necessary to define uniform valuation rules both in time and across regions. Generalized accepted accounting principles (GAAP) define a set of general standards, conventions and rules to assemble and report financial accounting information objectively. The international standards are often translated into practice locally by a national governing body that defines the national GAAP. Many countries have recently evolved

<sup>46</sup> From a regulatory perspective, the bank's capital is defined as different from the shareholder's equity.

towards or will converge towards the International Financial Reporting Standards (IFRS) that are established and maintained by the International Accounting Standards Committee. Note, however, that smaller locally operating companies may continue to apply the national GAAP.

These local implementations may differ across countries and evolve in time. Such changes need to be documented and, to the extent possible, their impact addressed in the model and assessments. In 2006, recent changes – like IFRS – may be too recent to know the impact on beforehand. When some data is available, statistical techniques may help to adjust the rating model. Data used for model development and model use need to be consistent across time. Stratified variables have to be defined coherently and sufficiently stable. The strata means have to be defined sufficiently robust, i.e. on a sufficient number of observations and sensitivities to extremely large or small values have to be avoided. Judgmental variables are less sensitive to outliers or wrong-definition effects. The main issue is the coherent interpretation and assignment across time and region within the organization. Blind tests can be organized to assess such correct interpretations.

Ethical considerations may prevent the organization using certain variables in the risk analysis. Such ethical restrictions may also be imposed by law. The Equal Credit Opportunities Act (1976) and regulation B in the United States prohibit the use of characteristics such as gender, marital status, race, whether an applicant receives welfare payments, color, religion, national origin and age in making the credit decision [122]. Furthermore, when rejecting an applicant for credit, he/she must be given specific reasons to motivate the decision.

For each of the variables that are evaluated, a complete ratio definition needs to be provided and the ranges of the variable components, for which the resulting variable is valid, need to be indicated.

#### **4.4.4.5 Data sources**

Explanatory data is available in many types: accounting information from publicly disclosed annual reports, internal information on the counterpart in the bank, national and international data sources.

The use of large external databases that collect annual reports and pre-process the databases in some standardized format is useful and reduces time-consuming manual data collection. When such external databases are used, it is important to understand the data so as to reproduce them when necessary. External providers may not cover the whole portfolio or in extreme cases may stop their activity.

A clear hierarchy is necessary on which data sources to consult when the data is no longer available from the reference database. Generally, internal data and external data from official sources are preferred above other external sources and data-pooling initiatives for reasons of data consistency and reproducibility. Some external and data-pooling initiatives provide complete documentation on variable definition, which allows a reduction in data-gathering efforts while keeping the advantages of internal data sources.

### 4.4.4.6 Examples

When constructing an internal rating system or analyzing a counterpart, one analyzes the available information on the counterpart.

For firm counterparts, accountancy information is available from annual reports. From the extensive literature and review studies [14, 28, 69, 83, 87, 94, 135, 150, 159, 189, 205, 211, 280, 303, 315, 320, 324, 327, 346, 358, 373, 383, 384, 463, 465, 467, 487, 521, 522] it is clear that a large number of different financial ratios have been proposed in the business failure and bankruptcy literature. Income statement or balance sheet information allows construction of typical quantitative variables listed in Table 4.3. Such variables measure a firm's ability to meet short-, medium- and long-term financial obligations. The variables also measure a firm's capital structure and financial leverage. The profitability group contains ratios and measures that provide information on the firm's return-generating ability and financial performance. Such variables are not purely profit based, but also include cash flow and sales-based measures. Partially related to profitability measures are the volatility-based measures on profitability stability. Growth variables are typically ambiguous variables: both extreme high and low growth indicate higher risk. Activity measures give an indication of the organization and the efficiency of the business activity. Larger firms typically are less risky such that size-related variables are important. For other firm asset classes [63] in the subcategory of specialized lending<sup>47</sup> (project and object finance, commodities finance and real estate) not all of these quantitative ratios can be calculated and qualitative variables are used instead [396]. Observe that some of the variables in Table 4.3 are related to the structural models discussed above.

For insurance companies and banks, some variables are closely related to the ratios used in firms. An important difference is the importance of

<sup>47</sup> The Basel II risk weights for specialized lending categories are discussed in Chapter 6.

**Table 4.3** Commonly used variables for firm counterparts.

---

**Profitability:** Profitability ratios measure the profit-making ability of the firm. They typically compare net income, net income less extraordinary items, earnings before income taxes and depreciation adjustments or earnings before income taxes with either total assets, tangible assets, fixed assets, sales or turnover. Some benchmark profitability ratios are return on average assets and return on equity.

**Leverage and gearing:** Leverage/gearing ratios measure the debt level of the firm compared to the firm size or equity. Some classical leverage ratios are liabilities to assets/equity and long-term debt to assets/equity.

**Growth:** Growth variables report the evolution of the key balance sheet and profit and loss statements, e.g., debt growth, sales growth, asset growth. These indicators may be quite volatile. Some authors report that both high and low growth may indicate instability and higher default risk.

**Liquidity:** Liquidity ratios (cash and marketable securities, current ratio): better liquidity implies lower default probability, especially for non-investment grade companies. The current ratio compares the projected cash inflow to the projected cash outflow for a period of 3–6 months. It gives the ability of the institution to meet short-term obligations.

**Activity:** Activity ratio measures such as inventories to sales, accounts receivable to turnover, may indicate abnormal functioning. High inventory levels may indicate production capacity problems and higher default risk.

**Size:** Size variables measure the magnitude of the firm, e.g., by sales, total assets, market capitalization and equity. Larger companies are typically better diversified and have less equity volatility.

**Volatility:** higher equity volatility implies higher probability of a firm's asset value below its debt level, and as such, higher insolvency and default risk. Volatility measures are not restricted to equity volatility, but also cash flow or earnings volatility measures can be used. Volatility measures are based upon accountancy information and are more difficult to define than equity volatility observed from daily stock market prices.

---

capital adequacy variables that measure the size of the equity buffer with respect to the risks the insurer or bank are exposed to [102, 243]. Rating methodology studies of the agencies are a useful information source for variable definition, see, e.g., [323, 389]. Example variable types are reported in Tables 4.4 and 4.5. The variable types for banks are organized along the CAMEL variables<sup>48</sup> that represent capitalization, asset quality, management quality, earnings and liquidity [170, 180, 208, 294, 310, 325, 357, 363, 423, 466, 488, 509]. Qualitative variables like management quality, organizational efficiency, financial flexibility, market position and risk profile are also useful judgmental variables for firms, insurance companies and banks.

<sup>48</sup> CAMEL is a supervisory tool in the US, its ratios intend to protect the solvency of institutions and the safety of member deposits [180].

**Table 4.4** Commonly used variables for insurance companies.

---

- Capital adequacy:** these variables compare the capital of the insurer compared to its risks. Examples are capital adequacy ratios, solvency ratios and the free reserve ratio.
- Leverage and debt:** the higher the debt of the company compared to its size, the higher the risk of the company. Some debt ratios are debt/surplus, debt/net premium written, debt/gross premium written. Leverage ratios compare the size of the business, liabilities and risks to the capital of the insurer, like, e.g., in gross premium written/surplus, net premium written/surplus and net premium written/net technical reserves.
- Performance and profitability:** These ratios measure the efficiency of the company to control expenses, risks and losses. For insurance companies, important ratios are the expense, loss and combined ratio, as well as investment returns. The profitability ratios represent the ability of the insurer to generate profit, measured by, e.g., return on shareholder funds, return on total assets, profit margin.
- Liquidity:** Liquidity ratios measure the amount of cash and other short-term/liquid positions of the insurer, reflecting its ability to absorb short-term changes in claims, liabilities, . . .
- Cash flow:** these variables try to capture the evolution of the insurer's cash position, which is the result of incoming cash streams (e.g., net premiums written and net investment income) and outgoing cash streams (e.g., underwriting expenses and commissions, investment losses, paid claims, taxes).
- Size:** the size of an insurance company can be measured by the gross/net premium written, total assets, surplus, gross/net technical reserves. Larger firms exhibit less equity volatility and, hence, are less risky.
- 

**Table 4.5** Commonly used CAMEL variables for banks.

---

- Capital adequacy:** a strong bank has a strong capital buffer to absorb unexpected losses. The Tier 1 ratio and total capital ratio compare the bank's risk weighted assets to its capital. Other capital ratios are closely related to leverage ratios (e.g., equity/total assets and debt/total assets). Leverage ratios can also be considered as a specific variable type.
- Asset quality:** because banks invest in assets, the quality of the assets indicates their net worth and gives information on future losses. Some examples of such ratios are: loan loss ratio, loan loss provision ratio and reserve ratio.
- Management:** the quality of the management is very important for efficiency of the operations and strategic decisions of the bank. Management quality can be measured as a judgmental variable, but also via cost-control ratios (cost per unit of money lent, cost per loan made) and efficiency measures (portfolio size per credit officer, management staff).
- Earnings:** Earnings or profitability ratios indicate the ability to make profit (e.g., return on average total assets, return on equity, return on performing assets, cost to income, self-sufficiency ratio)
- Liquidity:** the liquidity indicates the short-term solvency of the bank. Liquidity is especially important for very weak banks. Liquidity risk is believed to be one of the big challenges for banking in the coming years.
-

**Table 4.6** Commonly used variables for local governments.

---

**Debt:** Debt burden and level of indebtedness provide information on the level of debt with respect to the richness or income. The higher the debt burden and debt level, the higher is the default and loss risk.

**Exploitation:** Profitability and exploitation efficiency indicators measure the ability of the counterpart to generate a net positive income and to control the budget. Exploitation efficiency is measured, a.o., by personnel, management and maintenance costs.

**Self-financing ability:** Self-financing ratios report the ability of the public entity to finance its growth and future development by its own income stream or savings.

**Macroeconomic and demographic elements:** Demographic indicators and asset quality variables measure the local wealth (e.g., GDP/capita, poverty level), tax or price level (average tax rate) and the quality of the patrimony (income margin). Such variables give further insight on the financial flexibility in the near future.

**Size:** Size variables measure the number of inhabitants, tax base and/or turnover. Larger entities are assumed to have typically a larger income basis and better management competencies.

---

Financial information on countries and sovereigns is available from official international sources like the IMF and the World Bank. Table 4.7 presents typical variables for sovereign counterparts [36, 102, 112, 115, 120, 229, 262, 273, 294, 314, 318, 328, 347, 385, 411, 438, 462, 489]. Macroeconomic demographic variables reflect the economic structure of the country. Important variables like the Gross Domestic Product (GDP) indicate the wealth and productivity of the economy on which the state can raise income via direct and indirect taxes. Debt variables reflect the level of indebtedness of the country. Long- and short-term debt is compared with economy size variables. Other variable types like the social development, political environment and state efficiency are indirect indications of stability and growth potential. Other quantitative variables are the country's size as a measure for the importance in the global economy and the trade openness. Countries with higher trade openness may be less tempted to declare default because of the impact on the global economy.

For public sector entities, important variables are (local) macroeconomic and demographic variables as well. The health of the public sector is determined by the strength of the local economy and the management of the local authority. Other variables that are important are debt structure, exploitation result and self-financing ability [175, 309]. Important differences of sovereigns and public sector entities with firm counterparts are legal and institutional differences. Although sovereign and public sector counterparts may be subject to severe bankruptcy risk, liquidation risk is less important



**Table 4.7** Commonly used variables for sovereigns.

---

<b>Social development level:</b>	overall population development level (demographics, revenues distribution, health and education, status of the woman) and the state of collective infrastructure (railways, roads, access to running water, power generation). Typical indicators are GDP per capita, unemployment rate, Gini coefficient, human development index, life expectancy, health expenditure, adult literacy, poverty.
<b>Macroeconomic environment:</b>	overall economic structure and performance of a country: production, revenues, consumption, investment, savings, balance of payments. Typical indicators are GDP, GNI, economic growth, gross capital formation, current account balance/GDP.
<b>Debt:</b>	Debt indicators are particularly important in the assessment of the creditworthiness of a country. Public debt as well as external debt are to be considered in their various dimensions: flows vs. stocks, local currency vs. foreign currency, short term vs. long term, revenues vs. expenditure. Repayment ability is estimated by comparing short- and long-term debt with GDP, public receipts, current account receipts, international reserves.
<b>States and markets:</b>	Price and currency variables give more market-related information covering the monetary and exchange rate policies. Example variables are: exchange rate and interest rates, inflation, spreads, terms of trade, competitiveness.
<b>State efficiency:</b>	functioning of the central government (political environment, corruption, quality of the administration, enforcement of law and order) and relations with competing power centers (consensus across the political spectrum, support of Parliament and population).
<b>Stability:</b>	Banking sector and credit policy, macroeconomic stability (e.g., credit growth), destabilizing impact of internal and external conflicts or the risk upon conflicts, access to key resources (water, energy, commodities, . . .)
<b>Political regime:</b>	Political regime, institutions and legal environment: institutional framework of a country, political rights and civil liberties and the legal environment, economic freedom.

---

and long-term recovery plans are possible, on condition that there exists debt-servicing willingness at the defaulted counterpart.

For retail customers, known criteria for application scoring have been the 5 Cs (character, capital, collateral, capacity and condition) explained in Chapter 2, which are subjective measures that originated from the area of qualitative scoring. With increasing IT systems and data availability, other variables have been added [29–31, 38, 39, 122, 141, 156, 191, 238, 239, 240, 249, 250, 333, 455–457, 476, 477, 515, 518]. Nowadays, more objective quantitative and objective qualitative criteria listed in Table 4.8a are used. The variables for application scoring are often augmented with variables for behavioral scoring for current, active customers. The behavioral score can partially or entirely replace the application score for longer-term customer applications. The behavioral scoring is based mainly on dynamic variables

**Table 4.8** Commonly used variables for retail.**a) Application score variables:**

**Sociodemographic variables:** these give a general picture of the borrower. Such socio-demographic elements may include age, profession, residential status, postal number, address, ... Type of profession and sector of the profession (e.g. industry codes SIC, NAIC, NACE) are also considered to be in this category.

**Financial indicators:** income, income volatility, debt, debt burden, net saving margin. These measure, a.o., the capacity to pay back the loan.

**Product information:** type and purpose of the loan, collateral, insurance, amount, monthly payments (e.g., compared to salary, income, savings), amortization scheme. Although collateral is not a direct indicator for default risk, it can be part of an application scoring discrimination and decision scheme.

**Customer information:** the type of relation with the bank, the length of the customer relationship, behavioral scoring information, information from external organizations (e.g., national bank black list of defaulted counterparts, bureau scores, central databases with debt information at other credit institutions).

**b) Behavioral score variables:**

**Flow variables:** measure the number and amount (flux) of credit and debit operations on a given time period (last trimester, semester or year).

**Interval measures:** indicate a time period between two events, e.g., number of days payment delays, number of days with negative current account balance, number of days since last credit/debit transaction.

**Customer relation measures:** length of customer relationship, intensity, number of months customer uses a product.

**Product status management:** doubtful loans, pre-default, default, blocked credit facility, workout process.

**Flash volume variables:** amounts on current accounts, savings accounts; current short-term and long-term debt levels; arrears; credit line per product.

**Debt level and debt burden:** total amount of debt compared to income or savings, monthly income; possibly corrected for fixed expenses.

**Demographic customer information:** age, profession, marital status, number of children, nationality, residential status, information by official organizations: black lists of bad payers, past default experience, personal debt level,

**Other:** Additional variables measure more complex estimates, e.g., minimodels that estimate the maximum debt level and burden given the current income of the customer and relate the real debt level and burden to this maximum.

derived from the behavior type, cash flows, etc. It is typically applied on the customer level, while application scoring is more specific for a customer product. Typical variables for behavioral scoring are given in Table 4.8b. The analysis is done for all or for a relevant subset of products: current accounts, credit cards, saving accounts, stock/securities account, revolving credits, personal loans, mortgages, ... In most cases, variables are measured on the aggregate level.

**Table 4.9** Commonly used variables for LGD analysis.

---

**Features of the issuer:** the characteristics of the counterpart indicate recovery plans in the case of a default. Some typical counterpart features are the creditworthiness of the borrower (long-term rating, distance to default), the industry sector classification and industry conditions (relative default rates, stock market performance, . . .), the size, legal structure, age, country of residence and its legal environment, balance-sheet structure (e.g., leverage and gearing), financial flexibility to increase revenues to repay debt in case of distress; number of creditors.

**Features of the issue:** absolute and relative seniority (loan, bond (senior secured bonds, senior unsecured bonds, senior subordinated bonds, subordinated bonds, junior subordinated bonds), preferred stock), product type, type and value of the collateral, guarantees, exposure/size, length and costs of the workout process (if known a priori), (remaining) maturity, syndication.

**Macroeconomic factors:** economic conditions, default rate levels, interest rate levels, GDP growth, . . .

**Relation between bank and borrower:** intensity of the relation of the bank with the counterpart, length of the relation.

---

Specific variables for LGD modelling are summarized in Table 4.9. The literature on LGD modelling is still developing [16, 23, 26, 42, 61, 157, 158, 166, 193, 198, 201, 202, 226, 227, 233, 271, 319, 367, 418, 432, 453, 477]. It is intuitive that both issuer and issue characteristics are present. Both quantitative and qualitative issuer variables are mentioned. When using internal data sources, it is often possible to evaluate the explanatory variables used for the PD model also for the LGD model. Industry sectors are generally believed to explain differences in LGD values: utility sectors are less risky than high-tech sectors with less tangible assets. The important issue and discussion point on sector information is its predictive nature: industry sectors that observed a major crisis will typically be classified as bearing a higher loss risk. From a predictive viewpoint, a sector that is highly likely to face overcapacity in the coming years will bear a higher loss risk, although past losses may have been relatively low. Legal systems may differ from country to country and be more favorable for creditors depending on whether the system is based upon common or civil law [319]. Issue-specific variables include the relative and absolute seniority as the most important ones. LGD values are typically product dependent. Collateral information and collateral value are also important features. Other variables include macroeconomic variables, especially to measure downturn conditions and bank-customer-specific relations. For some counterparts, negotiation power is also an important element. This is typically perceived for sovereigns [409].

Large firms may try to negotiate a distressed exchange instead of a costly bankruptcy procedure. LGD values may also depend strongly on internal bank policies, contracts and procedures.

For EAD modelling, even less literature is available [22, 27, 61, 166, 366]. Also for EAD information, it is not implausible that the same types of explanatory variables as for LGD modelling appear in the list of candidate explanatory variables. In addition, product and covenant specific features are likely to be important, as illustrated in Fig. 4.11. The more restrictive the covenant is regarding the conditions for which the letter of credit can be drawn, the lower will be the resulting CCF. Exposure risk is especially important for revolving credits. The potential future exposure on derivative products, mainly in terms of exposure to banks and financial institutions, exhibits more complex behavior. When a gain on a derivative is made, it becomes a claim on the defaulted counterpart. In the case of a loss, it becomes an obligation to the debt holders of the defaulted counterpart. The exposure behavior depends, a.o., on the performance of the credit derivative and its underlying asset.

## 4.5 Development

### 4.5.1 Choice of model type

For the development of a model, one needs to decide which type of procedure will be applied. A complete new development dedicated to the portfolio and the problem formulation is typically the preferred choice. In such cases, one proceeds with all steps of the development process depicted in Fig. 4.20.

In the case of limited data availability, e.g., a low default portfolio, it is possible to use a generic scorecard and evaluate the quality of the selected scorecard: discrimination ability, correct calibration, migration analysis, benchmarking and expert analysis. Before applying a generic model, its applicability needs to be justified. The generic model is preferably a statistical model or an expert model of which the quality has been proven statistically. Generic models can be obtained from vendors or internally from a similar asset class.

For portfolios with some data available, one can start from a generic scorecard or model and adapt it to the specific features of the portfolio. The adjustment can be done in an expert way or statistically, e.g., by partial regression or a Bayesian analysis.

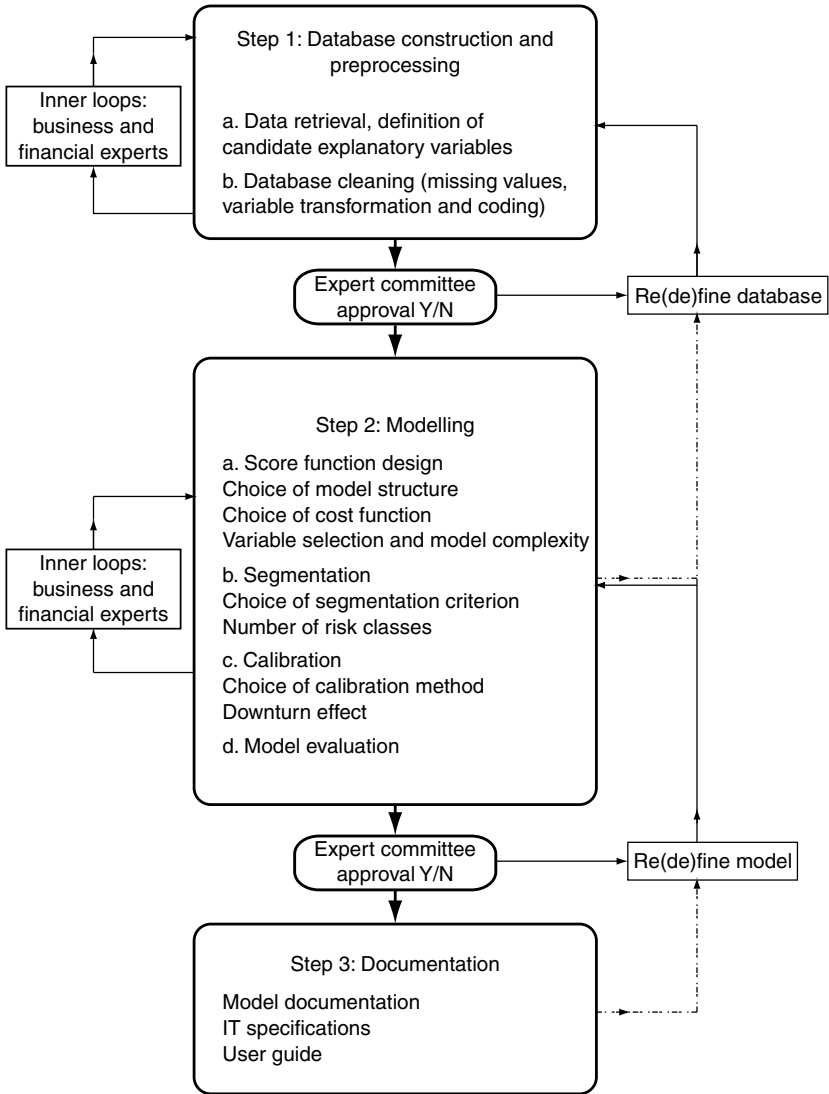

**Fig. 4.20** A process model for developing an internal-rating-based system. See text for details.

### 4.5.2 General design criteria

The design of a scoring function and rating system has to ensure that several performance criteria are met. The most important criteria are listed below:

1. A stable model is estimated with stable parameters estimated on a sufficiently large and long-term database.

2. A powerful, discriminative model is estimated that separates well between future defaults and non-defaults or that is sufficiently precise to distinguish low and high LGD/CCF values. In global models covering multiple segments, models with equal performance on all strata or segments are preferred.
3. The model is readable and is financially intuitive and meaningful (e.g., the model output needs to improve when an input variable decreases or increases; the most important ratio types should be represented in the model). The model results should be easy to interpret. Financial intuition and expert knowledge may also require coherent results with literature findings and similar model results with other models at the perimeter edges (e.g., continuous rating results between large professionals and small midcorps, large midcorps and small firms, . . .).
4. The model provides a good balance between model simplicity and complexity. The model has to avoid significant and material biases on any subportfolios. Overreliance upon one single risk factor needs to be avoided.
5. The model is conservatively calibrated. It yields accurate and conservative risk estimates that reflect sufficiently downturn conditions when required.
6. The model ratings are sufficiently stable, through-the-cycle and forward-looking and do not exhibit unnecessary volatility.

These design criteria act as constraints in the model development. Some constraints are hard constraints (e.g., statistical stability, correct calibration). Financial constraints are softer constraints because of their formulation. Other types of constraints are IT constraints, e.g., on the model formulation or on the variable choice that allows easier implementation.

A key question that is often raised, is to what extent each criterion needs to be addressed and whether there exist explicit quantitative criteria. Unfortunately, many of these criteria are case dependent. Internal bank design guidelines may emphasize more or less some of these criteria.

Each model is an important asset for the bank in terms of investment and has a high impact on the decision-making process and the organization. Therefore, its performance will be evaluated by means of internal and external validation procedures and monitored by the quality control and backtesting processes. The performance of the models used for Basel II is directly related to the accuracy of the internal risk assessment process that

the banks need to report for pillar 3 to the financial markets. The design has to be done such that the model is sufficiently robust to pass these tests successfully in the near future.

The design has to find a balance between the different criteria. The third criterion is met by consulting with financial experts during the design process. For structural models, it is required that the theoretical model assumptions are sufficiently met.

The first criterion is met with statistical techniques, e.g., a minimum floor on the significance level in a hypothesis test as explained in Book II for empirical models. When a sufficiently large database is constructed with a large set of candidate explanatory variables, it is likely that one can select a final financial and statistical empirical model of which the performance is sufficiently close to the pure statistical model with maximal possible discrimination or precision. This allows comparison of the predictive performance of the finally chosen model with this model having optimal discrimination or precision. Statistical techniques like complexity terms and hypothesis testing, allow unnecessarily complex models to be avoided. Financial expert evaluation helps in deciding upon the final model and avoiding unnecessarily complex models. Biases on sub-portfolios are avoided by evaluating the model on different data subsets. Techniques for conservative calibration take into account the uncertainty on the average risk parameter estimates, while also conservative margins for downturn sensitivities are added. The sixth criterion is not the least important: the output of a rating model should yield sufficiently stable output results. Unnecessary volatility or instability in the model output has to be avoided. The rating migration volatility can be traded with model discrimination or precision, e.g., by choosing longer-term averages as explanatory variables.

For expert models, less data will be available to verify all aspects quantitatively. While discrimination or precision are less straightforward to evaluate, it is important to verify at least the calibration.

The model design choices follow a hierarchy in the design choices. When sufficient data is available, models on internal data are preferred over pooled or external data. Models that predict defaults or LGD/CCF are generally preferred over mappings to default or recovery ratings. Objective explanatory data are preferred above judgmental data. Empirical models may be the first choice, structural and expert models are valid alternatives in the case of limited data availability.

### 4.5.3 Process model for design and development

The construction of the internal rating system is an iterative process. A process model is depicted in Fig. 4.20. The process model is mainly concerned with the development step of Fig. 4.1. Parts of data collection and the actual model are also covered. Notice that the design can be highly iterative and require many steps.

The iterative design is such that an optimal model is obtained given the financial and statistical constraints. Statistical experts co-operate with financial experts to merge the financial knowledge with the empirical findings. Especially in the first two steps of the design there are many interactions. In project management terms, the center of gravity of the development is typically shared between the risk management department, that will implement the model, and the quantitative analysis department that ensures correct and consistent model design. A committee of financial, statistical and business experts verifies the work after each major design step. The committee ensures that all aspects that concern the scope of the development project are met. The expert committee decides to go further with the next step or may decide to refine the previous work before proceeding further.

The number of iterations is especially large for new models that require an important learning curve. It may, e.g., happen that new risk drivers are discovered in step 2 by financial experts when analyzing incorrectly predicted defaults. It can become necessary to define new candidate ratios that explain this difference, but that were not defined in step 1. Hence, an update of the reference dataset with the additional candidate variable becomes necessary. Even after step 2, unexpected problems may appear in step 3 during the implementation such that it is required to refine the model in step 2 or in extreme cases in step 1.

#### 4.5.3.1 Step 1: Database construction and preprocessing

The development is triggered with the management's approval on the model construction. Based on the scope of possible model types, the most promising model type and modelling approach is selected. The database construction consists of the dependent- and independent-variable database construction. Depending on the information type (e.g., default data or mapping to external ratings; internal workout data or external market LGD data), the data source is chosen. Internal data can be readily available and corresponds very well to the internal portfolio, but may not be sufficiently rich to develop a statistical



model. Pooled data may be less representative of the internal portfolio. Commercial databases are available for some market segments, sometimes from different providers. Data reliability and availability are key factors in the data-source choice. The dependent- and independent-variable database can be obtained from different providers.

For statistical models, the data collection is a time-consuming task.<sup>49</sup> For the independent-variables database, the list of candidate explanatory variables is determined from a literature overview, business practice and/or expert knowledge. Financial and statistical experts collaborate on the definition of the candidate explanatory variables. The variable definitions are documented. For other model types, where the primary goal of the data collection is the model evaluation, the data-collection step requires fewer resources. A good design requires, nevertheless, historical databases with risk parameters to evaluate the calibration of the theoretical or expert model. For the dependent-variable database, one has to decide upon the information used for the data labelling: binary default or bankruptcy labelling, or external/internal ratings (PD models); historical workout LGDs, market LGDs or market-implied LGDs (LGD models); historical internal (workout) data, historical external data (workout or market), past market fluctuations for derivative data (CCF models). The database or dataset on which the model is designed is also called the reference dataset.

The modelling work starts with the database construction that will be used to design the rating model. The raw, initial dataset is then cleaned and pre-processed to obtain the modelling dataset. In the pre-processing step, the data is cleaned by missing-value treatment, outlier correction and representation of qualitative data. Outlier corrections concern the capping of the variables between a lower and upper limit so as to reduce the influence of outliers in the statistical procedures [236, 265, 266, 344, 417, 494]. The upper and lower limits are determined by statistical analysis, e.g.,  $3\sigma$  bounds and are validated from a financial perspective. Missing values are typically treated by the imputation of a neutral fixed value like the mean, median or mode, or of random values [335].

In some cases, the database with candidate explanatory variables needs to be linked with the database of dependent variables taking into account the data-delivery delay, and the prediction horizon as depicted in Fig. 4.19a.

<sup>49</sup> Estimates of Basel II cost allocation indicate that about 1/3 of the budget is required for the collection and purchase of data.

One also needs to choose the length on which the predictive variable is calculated and the number of years/periods that will be used for the model estimation, as illustrated in Fig. 4.19b. The observations with explanatory variables are labelled. Each observation in the training database needs to be labelled for supervised learning. The linkage can be done using a unique identifier key for each observation or by string recognition on the names. Observations without target labels are not useful in a supervised learning setup and are removed or properly treated (e.g., interpolation of the rating of the year before and after). Such observations can be stored in a separate data set for expert financial evaluation.

Notice that one can construct different databases for scoring function estimation and model calibration, given the different data requirements.

#### 4.5.3.2 Step 2: Modelling

The key statistical part is the second step in Fig. 4.20. The model design step involves the score function design, the segmentation and calibration. The presentation here is mainly done for statistical models, but the same structure is applicable for theoretical or expert models.

Notice that for theoretical models, the score function and calibration can be part of one formulation. In the Merton model, the score function design, corresponds to the distance to default formula (eqn 4.4). The calibration of the model results from the Gaussian cumulative distribution function (eqn 4.3). No segmentation is defined. A segmentation can be done via a mapping to a masterscale, by clustering the portfolio exposure or analyzing PD sensitivities to input-variable changes.

In expert models, the score function design, segmentation and calibration may rely a lot on expert data. Where possible, at least the calibration part is verified. For the use or adjustment of existing models in the development, one needs to verify to the extent possible the reasonability of the score function, segmentation and calibration.

The design takes into account the statistical and financial design constraints of section 4.5.2.

#### Score function

During the score function design the model structure, parameters and the explanatory variables are decided. Technical aspects are the choice of the model formulation, the cost function and estimation algorithm, and the choice of the overall model complexity. For statistical models, the score function design is done via supervised learning algorithms discussed in Book II.

Variable selection techniques determine reliable sets of explanatory variables. Models with a higher number of explanatory variables are generally more complex. The statistical variable selection results are contrasted with business and financial expertise and the score function may be refined iteratively to combine the statistical findings with expert knowledge. This process is sometimes called knowledge fusion.

For a theoretical or expert model, the score function does not require model estimation. The model estimation part is largely replaced by the expert construction of a model or by the theory supporting the model formulation.

The basic aim of the score function is to rank issuers or issues from low to high risk. For PD models, the better the ranking, the more future default counterparts are ranked at high risk and the more non-default counterparts receive good scores. For LGD and CCF models, the aim is to explain as much as possible the data and to ensure that high scores correspond closely to high LGD/CCF values and low scores to low LGD/CCF values. The better this is achieved, the closer are the real values around the observed values or the more precise the model is.

### **Segmentation**

Given the scoring function, the numerical risk characteristics (PD, LGD, CCF) are assigned to the different classes or buckets of the PD, LGD or CCF scoring function, respectively. Homogeneous pools with a similar risk profile are defined.

The segmentation needs to be done such that the resulting risk classes, segments or ratings represent a uniform risk measure within each class (intra-class uniformity) and different between-class (interclass) risks. According to section 404 Basel II [63], PD models are required to have at least 7 non-default risk grades, while it is also required that different risk classes represent different risks. section 405 specifies that rating modifiers can be used when such modifiers correspond to different risk classes and risk quantification. For LGD and EAD/CCF, no minimum number of risk grades is required. For LGD it is specified by section 407 that a large variation of LGD values in a single bucket has to be avoided.

Statistical criteria exist to perform (semisupervised) clustering given the number of classes. The latter is determined via complexity criteria as explained in Book II. The financial results need to be verified by the intuition of the financial experts. The segmentation of the continuous score into risk segments reduces the granularity of the model and hence, also, the model performance. The lower the number of risk segments, the bigger become the

intra-class differences, and hence the rating discontinuity. The model outputs become less refined/precise. The higher the number of risk classes, the more complex is the model output, but also the closer is the output aligned to the continuous score. A large number of risk classes may reduce interclass differences and introduce unnecessarily rating migration. When the number of risk classes increases, there will be fewer default events per bucket for calibration of PD, LGD or CCF. The power of the statistical evaluation of correct calibration in the backtest procedure is also reduced. A higher number of risk classes can help to reduce exposure concentration.

The choice of the number of risk classes is a complex task that is subject to the hard regulatory constraints and other soft constraints listed above. The number of risk classes is based upon statistical criteria, financial expertise and management oversight. In some cases, the number of classes is obtained implicitly with the score function design, e.g., with a mapping to external ratings. The number of risk classes and their definition can also be restricted by the number of rating scales that an organization wants to use.

### **Calibration**

The model calibration is the third step of the model design. It is a key step in a modern risk management perspective. The score function defines the ordering from high to low risk. The calibration quantifies this risk in terms of probability of default (PD), loss given default (LGD) or credit conversion factor (CCF) for each of the defined risk segments. The quantified information on PD, LGD and CCF will be fed into the portfolio models and risk weight functions to compute the capital requirements. These capital requirements become legally binding minimal capital requirements for the bank.

The quantification needs to be correct since the risk should not be over- or underestimated. Underestimation of these key parameters may result into a weakly capitalized bank. This explains the preference for overestimating the risk for reasons of conservativeness. Additionally, sharp or accurate PD, LGD or CCF estimates may not survive internal or external control in downturn periods, resulting into a positive correction and additional capital requirements. In order to avoid such scenarios, one often uses prudential estimates or adds a conservative margin (section 451 [63]) such that the resulting calibrated parameters are above the average risk parameters. However, when the risk is overestimated too much, the impact on the margins, etc., has a negative impact on the competitiveness of the bank, which should also be avoided. The level playing field concept is disturbed when banks

operating on the same market would be required to maintain different capital levels because different levels of conservatism are required. The level of conservatism is determined by the management given the uncertainty on the parameter estimates and their future evolution. For LGD and CCF, section 468 [63] requires a calibration to reflect downturn conditions.

The calibration is done on internal or external data. Internal databases are generally preferred above pooled data and external data, mostly for reasons of data and definition consistency. Whereas larger databases improve the generalization behavior of the score function, the calibration needs to be done specifically on the internal portfolio, which may also be influenced by other criteria like marketing strategy and business development. For reasons of data availability, the calibration dataset can be larger than the score function dataset (e.g., when performing a mapping to external ratings).

The calibration methodology depends on the rating philosophy. Point-in-time systems aim to predict as accurately as possible next year's risk as a function of the economic cycle and macroeconomic indicators. If the score function takes into account the economic fluctuations, the calibration needs to ensure that the risk level is correct during all points of the cycle and on average during the whole cycle. Through-the-cycle systems need to be calibrated such that the risk level is correct on average, possibly with more emphasis on the downturn period. The downturn LGD/CCF calibration for Basel II can be achieved by measuring the risk during downturn conditions only, or with a point-in-time system that is fixed at a downturn period of the cycle. Point-in-time calibrations can be very useful for correct pricing of short-term credits in emerging markets.

More details on calibration techniques are provided in Book II. An overview of calibration requirements for PD, LGD and EAD is given below. Because of the importance of the calibration, this design part is subject to important regulatory constraints for models applied within a Basel II context. Calibration is mainly a statistical issue, but financial and business experts may provide useful experience to discuss the statistical results.

### **PD calibration**

For default probabilities, one uses internal default databases, external default databases, internal/external reported default rates (e.g., rating agencies) or market-implied PDs that are inferred from market prices (equity returns, bond and credit default swap spreads) using an asset-pricing model. The most straightforward approach is to use an internal database with a sufficient history (e.g., more than 5 years section 463–466), apply the score function

and define homogeneous risk classes, and calculate the default probability yearly counting defaults versus non-defaults and averaging.

When not all internal defaults are used in the score function, e.g., due to lack of data, one applies a central tendency correction. In cases where the score function is estimated via a mapping to external ratings, one can use the default statistics reported by the external rating agency. When external databases are used, e.g., with external defaults or bankruptcy labels, one has to verify consistency between internal/external definition and apply a central tendency correction. The same holds for externally reported default rates. It may be necessary to identify conversion factors between bankruptcy rates and default rates, or between delinquency rates and default rates to have long-term default statistics.

Market-implied PDs are risk-neutral default probabilities, which may not correspond to real default probabilities. The results depend on the market perception of the implied risk, but can be an interesting alternative in the case of lack of other information. Note that, when it is opted to use data other than internal default data, it remains very useful to test the resulting calibration on the internal default data.

### **LGD calibration**

The LGD calibration is done based on information from workout data or defaulted bond prices. Workout LGDs take much longer to obtain than market LGDs, but in some banks these values are more realistic. Implied-market LGDs are inferred from market prices of non-defaulted assets, which are available on the large universe of non-defaulted assets. The LGD estimates depend on market conditions and the asset-pricing model.

When the LGD calibration is used for credit risk portfolio models that do not capture PD–LGD correlations, one often puts a higher weight on the economic downturn observations for the estimation of the average LGD for portfolios that exhibit positive PD–LGD correlation. Compared to the average PD, one does not average out the average LGD per year, but computes the default-weighted average (section 468) for Basel II calibration when no positive PD–LGD correlation is observed. Instead of taking the averages first per year and then using the simple average across all years, the default weighted average puts more emphasis on years with a higher number of defaults.

Difficulties with LGD calibration are the lack of data, the complex calculation of LGDs and the sometimes lengthy workout process. In some portfolios, more difficult defaults may require longer workout periods.

Hence, a calibration on only completed workouts may cause a bias. A calibration on the time period with only completed defaults can reduce the data sample for calibration significantly, and prevent the use of the most recent data. When it is opted to use data other than internal LGD data, it remains very useful to test the resulting calibration on the internal LGD data.

### CCF calibration

The credit conversion factor (CCF) must also be calibrated for products with off-balance sheet exposures. Given a scoring function or another set of criteria that segments the population, one computes the CCF per homogeneous group. Like for LGDs, one may also consider the cyclical effect of CCFs and a possible positive correlation in time with the PD. In such cases, the CCF can be estimated in downturn periods, or updated as a function of the economic cycle. The latter may cause additional fluctuations of the bank's capital requirements. The technical requirements for the CCF are similar to those of the LGD calibration. When it is opted to use data other than internal EAD data, it remains very useful to test the resulting calibration on the internal EAD data.

### Evaluation

The model evaluation is depicted at the bottom of the second step in Fig. 4.20. It is needless to say that the evaluation is partially done at each of the previous steps: discrimination/precision of the score function, quality of the segmentation and accuracy of the calibration.

At the end of the model design, a global model evaluation is done. Preferably, it is achieved on an out-of-time, out-of-sample dataset, i.e. a dataset that was not used for the model design and of which the data points do not coincide with the time period of the development data. Such test data allows assessment of the generalization behavior. Other techniques to measure the performance are explained in Book II. The performance evaluation is done on the global perimeter of the model, and on the different subsets in time and/or type (sector, region, seniority, product).

For each design step, there are adequate performance criteria like the cumulative notch difference, cumulative accuracy profile, mean squared error, negative log likelihood, model deviance, model evidence, ... The evaluation criterion has to be specified in line with the problem formulation. Statistical performance criteria are documented in Book II.

### 4.5.3.3 Step 3: Documentation

The approved model is documented extensively. The model documentation concerns the main choices made during the design. IT specifications and a user guide are written. These parts prepare the next step in the model life cycle of Fig. 4.1.

#### Model documentation

The model design documentation has to explain and motivate the choices made in each design step. Regulatory documentation requirements are listed in section 418 [63]. The documentation contains the model definition and how the resulting model complies with the specifications. The database definition and description are documented as well as the important steps in the score function design and calibration. A good documentation is such that an expert reader easily understands all the steps of the modelling process and is able to reproduce the same results on the same data. As an additional purpose, the documentation provides the reference source for internal and external (regulatory) model review. The documentation has to be compliant with the general internal guidelines on internal rating systems.

#### User guide

The user guide for the end-users is written and the tutorial for new users is developed. The financial analysts that use the scoring tool have to understand properly the functioning of the scoring tool. They need to be familiar with the input variables, understand their meaning and understand intuitively the impact of the key ratios on the model output. When the input variables are manually computed from the balance sheet, it is important to know and understand all fields used for the variable computation. When judgmental qualitative variables are used, the information has to be properly understood to ensure that the variable is assessed accurately and consistently, in line with the variable definition and guidelines.

The model results are used in the bank's internal decision-making processes (credit approval, pricing, provisioning, . . .). This has to be in line with the model definition and specifications. The model use has to conform with the model perimeter.

#### IT Specifications

The IT documentation specifies how the model has to be implemented in the global IT infrastructure for internal rating systems and its linkage with internal data markets for input-data retrieval and output-data storage.



Production data needs to be consistent with development data, within time and accuracy<sup>50</sup> constraints. The output data needs to be passed correctly to all data markets in the entire institution. The calculation engine on which the model will be implemented is reliable and has sufficient capacity for the possibly complex calculations on large databases. The rating system runs in a stable IT environment. The model inputs, outputs, intermediate results (e.g., PD rating before and after country ceiling; LGD before and after impact of collateral) are stored for a sufficient time horizon allowing a close model follow-up.

### 4.6 Implementation

During this step, the rating system is implemented in the organization. As a first step, the model is implemented via a thorough IT system that allows computation of the outputs and storage of all necessary intermediate results. Different models can be implemented using a generic IT system.

The goal of the IT system is to enhance the use of the model in the organization. Some elements of the model implementation in the organization are:

1. The model usage guidelines are specified (e.g., to which counterparts is the system applicable) and the user guide is communicated in the organization to ensure correct rating system application. Hierarchies between model use are defined (e.g., application scores for new counterparts and the first 6 months; behavioral models afterwards until a certain delinquency grade; collection scores afterwards). The hierarchy decides which model will be used (e.g., midcorp or large firm model based upon asset size or turnover, model for European or Asian counterparts for a company with shared headquarters, . . .).
2. The override procedure is specified that details how many notches up or down an override is allowed by the analysts, how many more by the rating committee. Internal quality control procedures are set up to monitor ongoing model use and correctness by random spot checks and more systematically important overrides.
3. Model monitoring and backtest procedures are defined. The IT tools that collect the data for such backtesting are developed. Triggers for a model update are specified.

<sup>50</sup> When historical data is available to a limited extent, one sometimes needs to proceed with automatic ratio calculations. In practical model use, ratios can be calculated more carefully as part of the expert analysis.

4. The rerating process is defined. One defines the frequency of the rerating, which is at least on an annual basis for Basel II. Sensitive and delinquent counterparts are monitored more closely. Risk grades that indicate sensitive issuers or issues are defined. Sensitive counterparts may also be subject to pro-active risk management with application of early warning models and active risk mitigation. Internal watchlist criteria are defined.
5. Internal databases with the most recent internal ratings are defined that are made public on internal data markets to the concerned personnel. The process for updating these ratings is determined and the vintage process in more automated systems is defined. These data markets are consulted by regulatory and economic capital engines, risk officers, credit officers, . . .
6. The use of the rating system results in the bank's decision-making process being documented in the internal guidelines. For example, delegation rules depending on the risk profiles are established to indicate the front office to what extent credits can be granted without specific approval from the risk management. Internal investment policies are put in line with the new rating system.
7. Modern credit risk management uses limit systems to enhance diversification and reduce exposure to large counterparts. Exposure limits are based upon the risk estimates of the new rating systems, e.g., depending on the PD, LGD and CCF rating.
8. The PD, LGD and/or CCF estimates define, together with the maturity, the required regulatory and economic capital that are used in RAROC calculations. A rating system change will require an update of the pricing of the products to maintain profitability.

These steps prepare the actual use of the model in the organization. The use test requires that the models for regulatory capital calculation do not serve only for this capital calculation, but that these models are consistently used in the bank's organization and decision-making processes.

## 4.7 Application and follow-up

Once the model is sufficiently provided with technical and practical documentation, it will be operational. Before putting a model officially operational, it needs to be internally validated [63]. The validation checks all critical assumptions and practical implementation of the rating system as will be detailed in section 4.8.

The correct application of the model is ensured by the previous steps that are supervised by internal and/or external (regulatory) auditors or teams with equivalent responsibilities. Data are fed into the model and the model is applied to the correct counterparts. The model results are stored on internal data markets. Once the model is officially applied, the model use and performance are monitored by the quality control and backtesting process.

A model is not a static tool, but will evolve with changing market conditions. Model follow-up maintenance is applied on the input data (e.g., when changing accountancy practices require ratio redefinition), on the score function parameters (e.g., with the yearly update or when discrimination decreases) or on the model calibration (e.g., adjustment of PD estimates on recent data and/or a longer time horizon). The maintenance is either triggered by internal guidelines prescribing a periodical review of the model, or by model anomalies observed by the quality control or during the backtesting.

After the model construction, one has to budget the time needed to ensure correct model maintenance. Even when using vendor models for regulatory purposes, the banks are required to understand the vendor models. Also, vendor models are subject to maintenance requirements. Hence, a model does not only present a one-time development cost, but also a recurrent cost.

## **4.8 Validation, quality control and backtesting**

Models bear a specific type of risk: model risk. Credit risk models are used to predict future risk levels: default risk, loss risk and exposure risk. The model risk is the risk that these model outcomes can be systematically wrong. Credit risk models are developed, implemented and used by humans, such that these are exposed to errors of wrong development, implementation and use. The aggregate of these risks is called model risk. Like any other risk, this risk has to be managed. A key element of model risk management is good development done by various experts from statistical and financial domains, internal validation at origination and ongoing validation through backtesting, benchmarking and quality control.

The validation process in a narrow sense<sup>51</sup> is an independent review of the development process and related aspects of model implementation. Quality

<sup>51</sup> In the wider sense, the term validation is used to cover all these 3 aspects: narrow sense validation, quality control and backtesting.

control concerns the ongoing monitoring of the model use, the quality of the input variables, the judgmental decisions, and the resulting model output. Backtesting is more quantitatively oriented and statistically compares the predicted risk parameters with the actual outcomes. The validation is carried out by audit, or an equally independent function.

The validation process follows the model life cycle of Fig. 4.1. The validation at origination reviews the first 4 phases that are concerned with the development. If the design is found to be sound, an official stamp is given that the model can be applied officially in the organization. During the model application, quality control is performed to ensure that the model is used correctly and that the model outputs are reasonable. After a while, sufficient data becomes available to statistically backtest the results of the rating process with the actual experience (e.g., predicted default/loss rate compared to actual default/loss rate). Narrow sense validation is performed immediately after the model design, but also after each (major) model update. Quality control is done continuously as long as the model is used. Backtests are carried out as soon as sufficient data is available. For Basel II purposes, this is done at least once a year (section 531 [63]).

The results of the validation, quality control and backtests are reported to the management. In cases with a lot of exceptions and consistent weak performance of the model, the management may decide to increase monitoring, model adjustment or even redesign the score function, the calibration or both. Depending on the criticality, the current model that exhibits the problems, may be put on hold and no longer applied until the problems are cured.

#### 4.8.1 Validation at origination

The validation in a narrow sense is a thorough examination of the model design process. The verification of the design concerns each of the different design steps.

**Model definition:** For the model definition step, it is verified whether the model request and objectives are clearly specified and correspond to the management's vision and strategy. If a new model is developed, one checks, e.g., how this fits within the global risk management perspective and compares the costs to the benefits. It is verified how the resulting model complies with the initial model request and business requirements.

**Data collection:** For the development database, the validation criteria checks the data collection, the quality of the data sources, the type of ratios, list of candidate explanatory ratios, data history and the model sample definition. The sample has to be representative of the model perimeter. A critical step is the data labelling, especially when using internal default information. The internal default list has to be complete (or one has to know the impact of an incomplete default list). For external data, the correspondence with the bank's internal processes needs to be motivated.

**Rating system development:** During the score function development phase, the methodological choices are verified. A solid motivation to use an expert, a statistical, a structural or a human judgment model has to be provided in the documentation. Other criteria involve the model assumptions, variable selection, model computation and statistical model choice. The validation criteria depend much on the problem at hand. It is important to verify that the most important assumptions are sound. The designers have to show that best practices and efforts have been applied.

The segmentation validation concerns the quality of the segmentation, its granularity, the number of risk grades, the resulting concentration, the reduction on the model quality, migration, . . . The applicability of the segmentation algorithm or the expert knowledge applied needs to be sufficiently motivated by the developers and has to be perceived as sufficiently sound by the validation team.

The calibration is the most important step, because the resulting risk parameters will be used in the economic and regulatory capital calculations. All assumptions made during the validation have to be carefully analyzed. The calibration must be done within internal and external (regulatory) constraints that specify a minimum data history and the way the risk parameters are calculated (e.g., the use of a downturn LGD estimate in the case of positive PD–LGD correlation [63]). When external data are used, one verifies the consistency of the data definition.

**Implementation:** Validation of the model implementation is concerned with the different aspects of the model implementation: IT implementation, model use and use test. The IT implementation is concerned with consistency checks between the statistical model and the resulting IT implementation. The model application is verified to be coherent with the usage guidelines and the philosophy of the development. At origination, this step mainly concerns the model use documentation; the correct use during application is verified by quality control. The use test validation

concerns whether the model and its results are sufficiently integrated in the bank's processes.

The validation report lists all findings on the different aspects of the model design and assigns a criticality level to the recommendations. The management defines an action plan to address the recommendations, before or subject to which model becomes officially valid within the organization.

#### **4.8.2 Quality control**

Quality control continuously monitors correct model use and model outputs. It is an ongoing process that verifies the rating process. The quality of the input variables is checked regularly by performing sample tests and by, e.g., recalculating the ratios from the official financial reports. For judgmental variables, an independent financial analyst gives his opinion and compares this with the financial analyst that assigned the internal rating.

The role of quality control is hierarchically separated from the risk management and commercial activities. The daily operations concern data quality and rating accuracy control. This is achieved by sample tests that are oriented towards known or potential model weaknesses like judgmental variables or subsectors on which the model performs less well. Benchmarking is also a useful selection criterion in the sample selection. Reviews can be done systematically on all ratings that differ by more than 2 notches from an external rating, or from the pure quantitative rating without human judgment. Override monitoring can be done automatically for all large differences on top of the sample tests.

Systematic benchmarking reports with statistical analysis are performed during the backtesting. The reports on the data integrity, rating accuracy and objectivity are communicated regularly to the management. The backtesting and the quality control both ensure model monitoring during its use.

#### **4.8.3 Backtesting**

The backtesting process is a detailed statistical follow-up of the model performance. The motivation to perform a backtest is intuitively clear. The (internal) risk assessments that one uses today are based upon statistical analysis of past data. These results are applied to new data, for which not necessarily the same conditions of the past and the assumptions made during the estimation process hold. After a certain amount of time, it is

reasonable to verify or backtest the accuracy and quality of the internal estimates statistically on the new out-of-time data. The backtest has to inform whether the *ex-post*, realized loss parameters (PD, LGD, CCF) correspond to the *ex-ante*, predicted loss parameters. The decision has to find a balance between type 1 errors (unnecessarily rejecting a good model) and type 2 errors (wrongly accepting a bad model). For Basel II, backtests should be applied at least once a year.

The backtest concept is an important aspect of internal market risk assessment to calculate internal capital. When the internal VaR-measures exceed a given test limit, a penalization factor is applied to the internal capital requirements. The primary concern of the credit risk backtests is the accuracy of the risk parameters PD, LGD and CCF. Of secondary concern is the power of the internal risk assessment to discriminate between high and low risk. Indeed, the main goal of the backtest is to make sure that the internal risk parameter estimates are adequate:

**PD calibration:** This involves checking the PD, hereby evaluating whether the number of *ex-post* realized defaults corresponds to the predicted number of defaults. As the yearly number of defaults can be low, especially when splitting up the observations across the different rating grades, the number of observations to carry out the backtest can be too limited to be conclusive. Therefore, it is useful to perform the test on aggregated data: on multiple years and on multiple ratings (e.g., investment grade and non-investment grade risk classes or even the full portfolio). A common, but simple test for the PD is the binomial test.

**LGD calibration:** The LGD backtest verifies whether the predicted losses correspond to the actual realized losses. The test is complicated due to the low number of defaults. The possible time dependence, due to correlation with macroeconomic factors, and possible correlation with the default risk, make it difficult to compare a long-term LGD history with a conservative LGD estimated during downturn economic conditions. Different LGD definitions (market LGD, market-implied LGD and workout LGD) do not reduce complexity. For workout LGD, the length of the workout process may delay the availability of internal LGD data. Also here it is advisable to backtest the LGD on aggregated LGD grades and multiple years. Apart from this issue, the non-symmetric and sometimes bimodal LGD distribution complicates the backtest even further. The z-test and t-tests for difference in means are simple tests when sufficient data is available.

**EAD/CCF calibration:** The evaluation of the exposure at default concerns the exposure data itself and the CCF to incorporate the off-balance sheet exposure. Similar difficulties as for the LGD apply for the CCF, e.g. possible correlation with macroeconomic conditions and the bank's lending policy. The CCF is a continuous variable like the LGD and the same tests can be applied. Whereas LGD modelling is still quite new, CCF modelling is even more pre-mature.

Banks are not only required to perform backtests, backtest guidelines need to be written and tolerance limits on differences between model results and observed outcomes need to be set.

Apart from the main credit risk parameters, the backtest procedure may also be concerned with the evaluation of the resulting loss distribution, although this requires a high number of observations. One may also evaluate indirectly the other loss distribution parameters, amongst which the correlation is the most important. Approximations to concentration effects via granularity adjustments can also be evaluated.

A good discrimination or precision has a direct impact on the profitability. Whereas factors for the discrimination/precision are estimated upon past data, it is intuitive that discrimination power or precision will be better on the training data than on out-of-sample and out-of-time data, on which the score function will be applied in practice. With slowly changing population characteristics, the discriminative power tends to decrease in time. Therefore, one monitors the discriminative power or precision of the models during backtesting.

**PD discrimination:** For PD discrimination models, the discrimination ability is monitored via measures for binary discrimination like the accuracy ratio (AR), Gini coefficient or the area under the receiver operating characteristic curve. The values are monitored in time and for possible parts of the population (economic sector and geographic regions). For a low number of defaults, one also applies benchmarking of internal ratings to external ratings.

**LGD and CCF precision:** For LGD and CCF precision, one uses correlation measures between the a-priori estimates and the *ex-post* realizations. One may also define LGD buckets and compare discrimination behavior between high- and low-risk classes via binary discrimination measures. One can also apply benchmarking with respect to external estimates to verify the correspondence.



Benchmarking involves comparison of internal estimates with external estimates. It involves a comparison on an ordinal multiclass scale. Such comparisons are made using specific correlation measures, like Kendall's  $\tau$ . Other measures involve summaries on the confusion matrix, like number of observations with 0 notch, 0–1 notches difference, 0–2 notches difference, etc. Such a comparison requires the expression of the ratings on a common scale.

Internal risk assessments typically include an objective quantitative part and a subjective judgmental part completed by human experts. The increasing importance of internal risk assessments puts more emphasis on the objectivity of internal risk assessments. Backtests on the quality of judgmental impacts become increasingly important. Simple comparisons include the comparison of the average risk parameter estimate before and after the human expert judgment. The improvement in discrimination behavior is also verified.

A final concern during backtesting are stability issues:

**Macroeconomic and institutional stability:** When the macroeconomic, institutional or legal environment in which the model operates changes, significant impacts can be expected on the model results. At least once a year, it is assessed whether there are known future changes that may involve a drift or structural change in risk estimates.

**Population stability:** The stability test verifies whether the population on which the model is applied remains relatively stable, such that one can assume that the risk parameters also remain stable. If the portfolio drifts away from the reference dataset, one needs to be more careful with applying a model that does not have a long history on new parts of the portfolio.

**Migration stability:** The model output stability is evaluated. Large migrations from low- to high-risk segments and vice versa are analyzed.

The statistical aspects of the backtest requirements are provided in Book III.

# 5. Portfolio models for credit risk

---

## 5.1 Introduction

An important concept of modern banking is risk diversification. In a simplified setting, the outcome of a single loan is binary: non-default or default, with possibly a high loss as a result. For a well-diversified portfolio with hundreds of loans, the probability of such a high loss is much smaller because the probability that all loans default together is many times smaller than the default probability of a single loan. The risk of high losses is reduced by diversifying the investment over many uncorrelated obligors. By the law of large numbers the expected loss in both strategies is exactly equal. The risk of high losses is not equal. Because bank capital serves to provide protection for depositors in case of severe losses, the first lending strategy of one single loan requires the bank to hold much more capital than the second lending strategy with a well-diversified portfolio. The diversification impacts the capital the bank is expected to hold and also performance measures like return on capital and risk-adjusted return on capital.

Portfolio models provide quantified information on the diversification effects in a portfolio and allow calculation of the resulting probabilities of high losses. On a portfolio level, the risk of the portfolio is determined by single facility risk measures PD, LGD and EAD and by concentration and correlation effects. On a more global view, migrations, market price movements and interest rates changes can also be included in the portfolio risk assessment to measure the market value of the portfolio in the case of a liquidation. Portfolio models have become a major tool in many banks to measure and control the global credit risk in their banking portfolios. Idealized and simplified versions of portfolio models are rating-based portfolio models, where the portfolio loss depends only on general portfolio parameters and the exposure, default risk and loss risk of each loan, represented by the PD

and LGD ratings, respectively. Exposure risk in such simplified models is currently represented by an equivalent exposure amount that combines on- and off-balance sheet items.

Such a risk calculation based on ratings is practically very useful and allows calculation of portfolio-invariant capital charges that depend only on the characteristics of the loan and not on the characteristics of the portfolio in which the loan is held. Rating-based portfolio models and the resulting portfolio invariant capital charges are of great value in the calculation of regulatory capital. In early<sup>52</sup> stages, loans were segmented based on rough criteria (sovereign, firm, mortgage, . . .) and risk weights for each segment were prescribed. The proportional amount of capital (8% of the risk weights) was prescribed by the regulators. The new Basel II Capital Accord calculates the risk of the bank using a simplified portfolio model calibrated on the portfolio of an average bank. In addition, the Basel II Capital Accord encourages banks to measure its portfolio risk and determine its economic capital internally using portfolio models.

The main components of the risk of a single loan, exposure at default, loss given default and probability of default, impact on an aggregated level the portfolio loss distribution as explained in section 5.2. Common measures of portfolio risk are reviewed in section 5.3. section 5.4 illustrates the impact of concentration and correlation on portfolio risk measures. Portfolio model formulations are reviewed conceptually in section 5.5 and an overview of the current industry models is given in section 5.6. Some of these models also include the risk of changing interest rates and spreads. The Basel II portfolio model for regulatory capital calculation is explained in detail in section 5.7. Application and implementation issues are reviewed in section 5.8. The concepts of economic capital calculation and allocation are summarized in section 5.9 and a survey of risk-adjusted performance measures is given.

## **5.2 Loss distribution**

### **5.2.1 Individual loan loss distribution**

Banks charge a risk premium for a loan to cover a.o. its expected loss. The expected loss reflects the expected or mean value of the loss of the loan. The expected loss depends on the default risk of the borrower, the loss

<sup>52</sup> A comparison between Basel I and Basel II risk weights is made in the next chapter.

percentage of the loan in case the borrower defaults and the exposure at the time of default. The loss  $L$  for a given time horizon or holding period is a stochastic variable that is

$$L = \text{EAD} \times \text{LGD} \times \delta_{\text{PD}}, \quad (5.1)$$

with

**EAD:** the exposure at default can be considered as a stochastic or a deterministic variable, the stochastic aspect is most important for credit cards and liquidity lines.

**LGD:** the loss given default is a stochastic variable that typically ranges between 0 and 100%. The LGD distribution is typically assumed to follow a beta-distribution or a bimodal distribution that can be fitted using kernel estimators. Sometimes, the LGD distribution is represented by combining a discrete distribution at 0 and 100% and a continuous distribution in between. The LGD represents the severity of the loss in the case of default.

**PD:** the probability of default follows a Bernoulli distribution with events either 1 (default) or 0 (non-default). The probability of default is equal to PD ( $P(\delta_{\text{PD}} = 1) = \text{PD}$ ), while the probability of non-default is equal to  $1 - \text{PD}$  ( $P(\delta_{\text{PD}} = 0) = 1 - \text{PD}$ ). The expected value of  $\delta_{\text{PD}}$  is equal to  $\mathbb{E}(\delta_{\text{PD}}) = \text{PD}$ , the variance is equal to  $\mathbb{V}(\delta_{\text{PD}}) = \text{PD}(1 - \text{PD})$ .

For credit risk applications, one typically applies a holding period equal to one year. In the case of independent distributions EAD, LGD and  $\delta_{\text{PD}}$ , the expected value of the loss probability distribution equals

$$\begin{aligned} \mathbb{E}(L) &= \mathbb{E}(\text{EAD}) \times \mathbb{E}(\text{LGD}) \times \mathbb{E}(\delta_{\text{PD}}), \\ &= \overline{\text{EAD}} \times \overline{\text{LGD}} \times \text{PD}, \end{aligned}$$

with expected or average probability of default PD, the expected loss given default  $\overline{\text{LGD}}$  and the expected exposure at default  $\overline{\text{EAD}}$ . The expected loss is the expected exposure times the loss in the case of default multiplied by the default probability. The expected loss is typically used for provisioning and/or calculated in the risk premium of the loan. Proportional to the exposure, the risk premium should cover the  $\overline{\text{LGD}} \times \text{PD}$ . This explains the appetite to invest in loans with low default risk, low loss risk or both, on condition the margin is sufficiently profitable. The proportional loss distribution of a single loan with constant LGD is depicted in Fig. 5.1a.

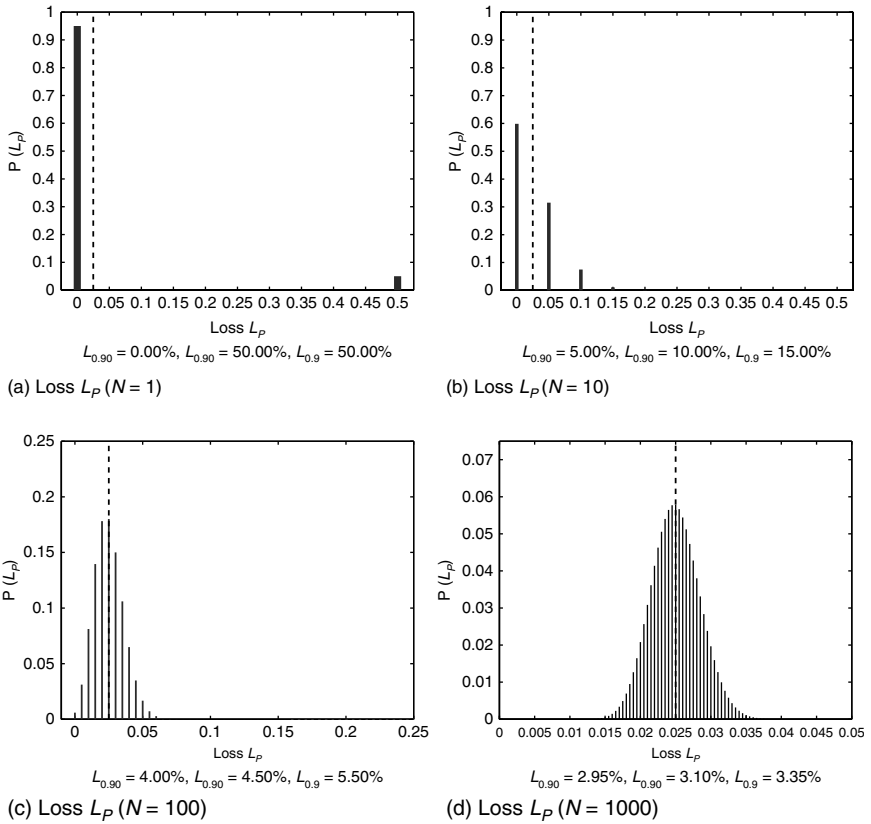

**Fig. 5.1** Loss distributions  $L_P$  for a homogeneous portfolio with  $N = 1, 10, 100$  and  $1000$  loans with fixed  $EAD = \overline{EAD} = 1$ ,  $LGD = \overline{LGD} = 50\%$  and  $PD = 5\%$ . The expected loss is indicated by the dotted line at  $2.5\%$ . The 90, 95 and 99th value-at-risk numbers are reported below each graph in terms of percentage of the total exposure  $N$ . With the same expected loss, the portfolio distribution is less risky because high losses are less likely to occur compared to the loss distribution of the individual loan. Note the different scales of the axes.

### 5.2.2 Portfolio loss distribution

The loss distribution of a portfolio composed of a large number of loans  $N$  is obtained by summing up the loss distribution of the individual loans

$$L_P = \sum_{i=1}^N L_i = \sum_{i=1}^N EAD_i \times LGD_i \times \delta_{PD_i}. \tag{5.2}$$

The expected loss of the portfolio is the sum of the expected losses of the individual loans:

$$\mathbb{E}(L_P) = \sum_{i=1}^N \mathbb{E}(L_i) = \sum_{i=1}^N \overline{\text{EAD}}_i \times \overline{\text{LGD}}_i \times \text{PD}_i.$$

In terms of the expected loss, there is no real diversification benefit for the portfolio. The expected loss of the portfolio is not lower than the expected loss of its loans.

However, the portfolio loss distribution can be totally different from the loss distribution of the individual loan. Indeed, the distribution of the sum of two independent random variables corresponds to the convolution of the two individual distributions. The convolution will smooth the discrete individual distribution in the case of deterministic EAD and LGD (Fig. 5.1a) into a quasicontinuous portfolio loss distribution.

Consider, e.g., a homogeneous portfolio of  $N$  loans with deterministic  $\text{EAD} = \overline{\text{EAD}}$  and  $\text{LGD} = \overline{\text{LGD}}$  that are equal for all counterparts. Assume for the moment that the Bernoulli distributions  $\delta_i$  are independent. The more general case of dependent distributions will be further discussed in section 5.4. The distribution of the loan portfolio is obtained as the convolution of the individual loan loss distributions. The procentual loss distribution of the portfolio is given by the following formula

$$P(L_P = \text{LGD} \times j) = \binom{n}{j} \text{PD}^j (1 - \text{PD})^{N-j}.$$

By the central limit theorem, the distribution tends to a normal distribution with mean  $\text{PD}$  and variance  $\text{PD}(1 - \text{PD})$ .

Figures 5.1a–d depict the loss distribution of a homogeneous portfolio of  $N = 1, 10, 100$  and  $1000$  independently distributed loans with  $\text{EAD} = 1$ ,  $\text{LGD} = 50\%$  and  $\text{PD} = 5\%$ . For small portfolios, the graphs depict already some important properties of the portfolio loss distribution: the distribution is fat-tailed<sup>53</sup> and skewed to the right. This is not surprising given the interpretation of a loan as a combination of risk-free debt and a short position on an option as explained in paragraph 4.3.1.1. The shape of the distribution is further influenced by concentration and correlation properties, as will be discussed in section 5.4. First, common risk measures are reviewed in the next section.

<sup>53</sup> In a fat-tailed distribution function, extreme values have higher probabilities than in the corresponding normal distribution with the same mean and variance.

### 5.3 Measures of portfolio risk

The portfolio loss distribution summarizes all information of the risk in the credit portfolio. For practical purposes, calculations, investment decisions, management and regulatory reporting, the loss distribution needs to be summarized into risk measures. These risk measures highlight one or more aspects of the risk in the portfolio [25, 82, 124, 260, 291, 468].

A risk measure  $\rho$  is said to be a coherent risk measure if it satisfies the following four properties [25]:

**Subadditivity:** the risk of the sum is less than the sum of the risks,  $\rho(X + Y) \leq \rho(X) + \rho(Y)$ . By combining various risks, the risk is diversified.

**Monotonicity:** the risk increases with the variables;<sup>54</sup> if  $X \leq Y$ , then  $\rho(X) \leq \rho(Y)$ . Riskier investments have a higher risk measure.

**Positive homogeneity:** the risk scales with the variables;  $\rho(\lambda X) = \lambda \rho(X)$ , with  $\lambda \geq 0$ . The risk measure scales linearly with a linear scaling of the variable.

**Translation invariance:** the risk translates up or down by subtraction or addition of a multiple of the risk-free discount factor;  $\rho(X \pm \alpha r_f) = \rho(X) \pm \alpha$ , with  $\alpha \in \mathbb{R}$  and  $r_f$  the risk-free discount factor.

The variables  $X$  and  $Y$  are assumed to be bounded random variables.

In the next sections, different portfolio risk measures are discussed. An overview of their most interesting properties is given in Table 5.1. Some are illustrated in Fig. 5.2. Ideally, a practical risk measure should comply with all the four properties. Some practical risk measures may not satisfy all of them. This means that there exist circumstances in which the interpretation of the risk measure becomes very difficult. For classical portfolios, such circumstances may occur rather seldom.

#### 5.3.1 Expected loss (EL)

The expected loss (EL) of a portfolio of  $N$  assets or loans is equal to the sum of the expected loss of the individual loans:

$$\text{EL}_P = \mathbb{E}(L_P) = \sum_{i=1}^N \mathbb{E}(L_i) = \sum_{i=1}^N \overline{\text{EAD}}_i \times \overline{\text{LGD}}_i \times \text{PD}_i. \quad (5.3)$$

<sup>54</sup> The risk is measured in absolute sense here.

**Table 5.1** Advantages and disadvantages of portfolio risk measures. The last column indicates whether it is a coherent risk measure.

Risk Measure	Advantages	Disadvantages	Coherent
Expected loss	Information on average portfolio loss, Direct relation with provisions	No information on the shape of the loss distribution	Yes
Loss standard deviation	Information on loss uncertainty and scale of the loss distribution	Less informative for asymmetric distributions	No
Value-at-risk	Intuitive and commonly used, Confidence level interpretation, Actively used in banks by senior management, capital calculations and risk-adjusted performance measures	No information on shape, only info on one percentile, Difficult to compute and interpret at very high percentiles	No
Economic capital, unexpected loss	Intuitive and commonly used, Confidence level interpretation, Actively used in banks by senior management, capital calculations and risk-adjusted performance measures	No information on shape, only info on one percentile, Difficult to compute and interpret at very high percentiles	No
Expected shortfall	Coherent measure of risk at a given confidence level, Increasingly popular in banks	Less intuitive than VaR, Only tail and distribution information for the given percentile, Computational issues at very high percentiles	Yes

The expected loss measure gives an idea on the average loss of the portfolio. This loss should be covered by the excess interest rate (with respect to the funding rate and costs) charged to the obligors. The expected loss gives information on the “location” of the loss<sup>55</sup> distribution, but not on its dispersion or shape. As illustrated in Fig. 5.1, it gives no insight into the probability of extremely large losses due to default of a large exposure, economic crises with waves of defaults and reduced recoveries, ... The expected loss is a coherent measure of risk.

<sup>55</sup> See the Appendix for the definition of the concepts location, dispersion and shape.



### 5.3.2 Loss standard deviation (LSD, $\sigma_L$ )

The loss standard deviation (LSD,  $\sigma_L$ ) is a dispersion measure of the portfolio loss distribution. It is often defined<sup>56</sup> as the standard deviation of the loss distribution:

$$\sigma_{L_P} = \sqrt{\mathbb{E}(L_P - \mathbb{E}L_P)^2}.$$

Because a normal distribution is completely defined by its first two moments, the EL and  $\sigma_L$  would characterize the full distribution when the loss distribution is Gaussian. However, credit loss distributions are far from normally distributed, as can be seen from Fig. 5.1b.

The loss standard deviation of a single loan with deterministic EAD =  $\overline{\text{EAD}}$  and independent PD and LGD distribution is given by:

$$\begin{aligned} \sigma_L &= \text{EAD} \times \sqrt{\mathbb{E}(L - \mathbb{E}L)^2} \\ &= \text{EAD} \times \sqrt{\mathbb{E}(\delta_{\text{PD}} \times \text{LGD} - \text{PD} \times \overline{\text{LGD}})^2} \\ &= \text{EAD} \times \sqrt{\mathbb{E}((\delta_{\text{PD}} \times \text{LGD})^2 - 2 \times \delta_{\text{PD}} \times \text{LGD} \times \text{PD} \times \overline{\text{LGD}} + (\text{PD} \times \overline{\text{LGD}})^2)} \\ &= \text{EAD} \times \sqrt{\mathbb{V}(\text{LGD}) \times \text{PD} + \overline{\text{LGD}}^2 \times \text{PD}(1 - \text{PD})}. \end{aligned}$$

The loss standard deviation of the loan increases with the uncertainty on the LGD and PD. Observe that for some commercial sectors, e.g., firms, the assumptions of independent LGD and PD may be too optimistic. Experimental studies on PD and LGD mention correlations for large firms [16, 133, 227, 432]. However, it is not yet clear how these experiments depend on the LGD calculations of Chapter 4 (market LGD, work-out LGD) and how these results can be extrapolated to loans of retail counterparts or other counterpart types.

The loss standard deviation of a portfolio with  $N$  facilities is given by

$$\sigma_{L_P} = \sqrt{\sum_{i=1}^N \sum_{j=1}^N \sigma_{L_i} \times \sigma_{L_j} \times \rho_{ij}}, \quad (5.4)$$

<sup>56</sup> Note that some authors use the concept of unexpected loss for the loss standard deviation. In this book, the unexpected loss corresponds to a value-at-risk measure like in the Basel II framework [63].

where  $\rho_{ij} = \rho_{ji}$  denotes the correlation between the loss distribution of the facilities  $i$  and  $j$ . In matrix form, the above expression becomes

$$\sigma_{LP} = \sqrt{\begin{bmatrix} \sigma_{L_1} \\ \sigma_{L_2} \\ \vdots \\ \sigma_{L_N} \end{bmatrix}^T \begin{bmatrix} 1 & \rho_{12} & \dots & \rho_{1N} \\ \rho_{21} & 1 & \dots & \rho_{2N} \\ \vdots & \vdots & \ddots & \vdots \\ \rho_{N1} & \rho_{N2} & \dots & \rho_{NN} \end{bmatrix} \begin{bmatrix} \sigma_{L_1} \\ \sigma_{L_2} \\ \vdots \\ \sigma_{L_N} \end{bmatrix}}. \quad (5.5)$$

When the exposure is assumed to be deterministic, the expression simplifies to<sup>57</sup>

$$\sigma_{LP} = \sqrt{\sum_{i=1}^N \sum_{j=1}^N \text{EAD}_i \times \text{EAD}_j \times \mathbb{C}[\text{LGD}_i \times \delta_{\text{PD}_i}, \text{LGD}_j \times \delta_{\text{PD}_j}]}$$

This calculation can be further simplified when assuming a fixed LGD:

$$\begin{aligned} \sigma_{LP} &= \sqrt{\sum_{i=1}^N \sum_{j=1}^N \text{EAD}_i \text{LGD}_i \times \text{EAD}_j \text{LGD}_j \times \mathbb{C}[\delta_{\text{PD}_i}, \delta_{\text{PD}_j}]} \\ &= \left( \sum_{i=1}^N \sum_{j=1}^N \text{EAD}_i \text{LGD}_i \times \text{EAD}_j \text{LGD}_j \right. \\ &\quad \left. \times \sqrt{\text{PD}_i(1 - \text{PD}_i) \times \text{PD}_j(1 - \text{PD}_j) \rho_{ij}} \right)^{\frac{1}{2}}. \end{aligned} \quad (5.6)$$

The impact of the default correlation  $\rho_{ij}$  and also the exposure concentrations ( $\text{EAD}_i$  and  $\text{EAD}_j$ ) will be further discussed in section 5.4. The expressions (5.4)–(5.6) indicate already the complexity of the loss standard deviation. Given the difficulty of obtaining analytic expressions without making too many assumptions, the loss standard deviation as well as the portfolio distributions are often calculated using simulation models. An overview of commercial portfolio models is given in section 5.6. The loss standard deviation fails to be a coherent measure of risk, it does not satisfy the second criterion [25].

Given a portfolio, one also wants to identify which positions cause most of the risk. The marginal loss standard deviation ( $\text{MLSD}_f$ ) measures the risk contribution of facility  $f$  to the portfolio loss standard deviation  $\text{LSD}_P$ :

$$\text{MLSD}_f = \frac{\delta \sigma_{LP}}{\delta \sigma_{L_f}} \sigma_{L_f}.$$

<sup>57</sup> The covariance of 2 stochastic variables  $X$  and  $Y$  is calculated as  $\mathbb{C}[X, Y] = \mathbb{E}[(X - \mathbb{E}[X])(Y - \mathbb{E}[Y])]$ . The covariance is related to the correlation  $\rho[X, Y]$  and variances  $\mathbb{V}[X], \mathbb{V}[Y]$ :  $\mathbb{C}[X, Y] = \rho[X, Y] \sqrt{\mathbb{V}[X] \mathbb{V}[Y]}$ .

Given expression (5.4), the marginal loss standard deviation is

$$\text{MLSD}_f = 2\sigma_{L_f} + 2 \frac{\sum_{j \neq f} \sigma_{L_j} \rho_{fj}}{2\sigma_{L_P}} \sigma_{L_f} = \frac{\sum_{j=1}^N \sigma_{L_i} \times \sigma_{L_j} \times \rho_{ij}}{\sigma_{L_P}}. \quad (5.7)$$

The marginal loss standard deviations of the individual facilities add up to the loss standard deviation of the full portfolio,  $\sum_f \text{MLSD}_f = \text{LSD}_P$ . It allows allocation of the total capital to the individual exposures and inclusion of the capital cost (e.g., required return on capital of 15%) in the calculation of the margin.

Part of the loss standard deviation can be reduced by a better diversification, e.g., by increasing the number of loans, as can be seen from Fig. 5.1. Nevertheless, a part of the risk cannot be diversified, e.g., macroeconomic fluctuations will have a systematic impact on the financial health of all counterparts. It is part of the bank's investment strategy to what extent one wants to diversify the bank's risk and at what cost. From a macroeconomic perspective, the bank fulfills the role of risk intermediation, as explained in Chapter 1.

### 5.3.3 Value-at-risk (VaR)

The value-at-risk (VaR) at a given confidence level  $\alpha$  and a given time horizon is the level or loss amount that will only be exceeded with a probability of  $1 - \alpha$  on average over that horizon. Mathematically, the VaR on the portfolio with loss distribution  $L_P$  is defined as

$$\text{VaR}(\alpha) = \min\{L | P(L_P > L) \leq (1 - \alpha)\}. \quad (5.8)$$

One is  $1 - \alpha$  per cent confident not to lose more than  $\text{VaR}(\alpha)$  over the given time period. The VaR is the maximum amount at risk to be lost over the time horizon given the confidence level. The time horizon or holding period for market risk is usually 10 days, for credit risk it is 1 year. The VaR depends on the confidence level and the time horizon. Figure 5.2 illustrates<sup>58</sup> the VaR concept. VaR measures are typically reported at high percentiles (99%, 99.9% or 99.99%) for capital requirements. The management is typically also interested to know the lower percentiles, e.g., the earnings-at-risk measure indicates the probability of a severe risk event that is less severe to threaten solvency, but will have a major impact on the profitability.

<sup>58</sup> For readability purposes, losses are reported on the positive abscissa.

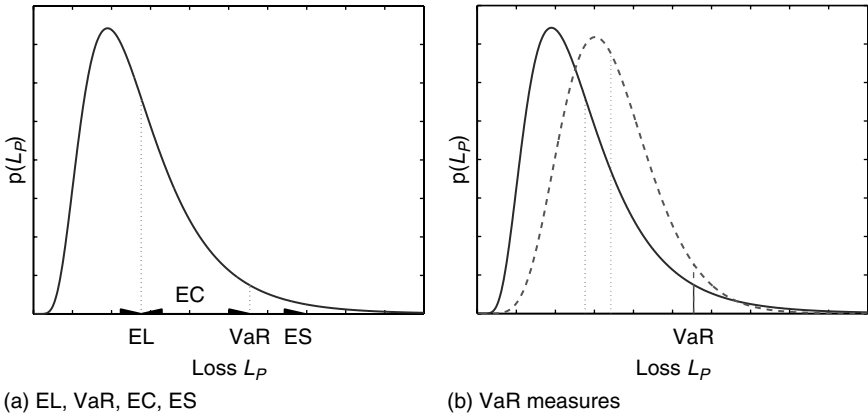

**Fig. 5.2** Expected loss (EL), value-at-risk (VaR), economic capital (EC) and expected shortfall (ES) are numerical measures to describe the main features of the loss distribution. Pane (a) illustrates the VaR, EC and ES at the 95th percentile. The right pane (b) illustrates that two loss distributions can have the same VaR, but different averages and tail distributions.

VaR is a well-known and widely adopted measure of risk, in particular for market risk (market VaR). The Basel II Capital Accord [63] also uses the concept of a 99.9% credit risk VaR and of a 99.9% operational risk VaR. Unfortunately, the VaR measure has important drawbacks. A major drawback is that the VaR does not yield information on the shape of the distribution and no information on the (expected) loss that can happen in  $\alpha$  per cent of the time when the portfolio loss  $L$  exceeds the VaR. For credit and operational risk, one typically uses very high confidence levels in the deep tail of the distribution. At these levels, all assumptions regarding correlations and distributions may have an important impact on the VaR. The VaR estimate can become unstable at high confidence levels. Moreover, VaR is not a coherent measure of risk, it does not satisfy the subadditivity property [25, 195].

Incremental VaR and marginal VaR are related risk measures that capture the effect of a facility  $f$  to the portfolio VaR $_P$  [215]. The incremental VaR (IVaR $_f$ ) measures the difference between the VaR $_P$  of the full portfolio and the VaR $_{P-f}$  of the portfolio with the facility  $f$ :

$$\text{IVaR}_f(\alpha) = \text{VaR}_P(\alpha) - \text{VaR}_{P-f}(\alpha).$$

The IVaR is a measure to determine the facilities that contribute most to the total risk of the portfolio. Its disadvantage is that the sum of the incremental VaRs does not add up to the total VaR of the portfolio,  $\sum_f \text{IVaR}_f \neq \text{VaR}_P$ . An alternative risk measure, intuitively closely related to the IVaR, is the

marginal VaR that measures the sensitivity of the portfolio  $\text{VaR}_P$  to the facility  $f$  with assets  $A_f$ :

$$\text{MVaR}_f(\alpha) = \frac{\partial \text{VaR}_P(\alpha)}{\partial A_f} A_f.$$

The sum of the marginal VaRs adds up to the portfolio VaR,  $\sum_f \text{MVaR}_f = \text{VaR}_P$ . The marginal VaR is also known as delta VaR.

### 5.3.4 Economic capital (EC)

The economic capital (EC) at a given confidence level  $1 - \alpha$  is defined as the difference between the value-at-risk and the expected loss

$$\text{EC}(\alpha) = \text{VaR}(\alpha) - \text{EL}. \quad (5.9)$$

It measures the capital required to support the risks of the portfolio. As the EC measure is based on the VaR measure, it has the same properties (not sub-additive, instability for high confidence measures). In some applications, one uses a capital multiplier  $m_\alpha$  to approximate the economic capital as a multiple of the loss standard error  $\sigma_L$ :

$$\text{EC}(\alpha) = m_\alpha \sigma_L. \quad (5.10)$$

For a normal distribution, the capital multiplier at 99%, 99.9% and 99.99% is equal to 2.3, 3.1 and 3.7, respectively. For more fat-tailed distributions, capital multipliers between 5 and 15 have been reported [133].

The extensions to incremental economic capital  $\text{IEC}_f(\alpha) = \text{IVaR}_f(\alpha) - \text{EL}_f$  and marginal economic capital  $\text{MEC}_f(\alpha) = \text{MVaR}_f(\alpha) - \text{EL}_f$  are easily made, where it should be noted that these measures depend on the portfolio they are part of.

When more portfolios  $P_1, P_2, \dots, P_n$  are combined, the EC of the whole is lower than the sum of the individual portfolio ECs (assuming subadditivity). The diversification benefit (DB) is equal to

$$\text{DB} = \frac{\text{EC}(P_1) + \text{EC}(P_2) + \dots + \text{EC}(P_n)}{\text{EC}(P_1 + P_2 + \dots + P_n)}. \quad (5.11)$$

The diversification benefit indicates the reduction in economic capital from a diversified investment strategy. Economic capital at the firm level will be discussed in section 5.9.

### 5.3.5 Expected shortfall (ES)

Expected shortfall (ES) measures the expected loss when the portfolio loss exceeds the VaR limit

$$\begin{aligned} \text{ES}(\alpha) &= \frac{\int_{\text{VaR}(\alpha)}^{\infty} (L_P - \text{VaR}(\alpha))p(L_P)dL_P}{\int_{\text{VaR}(\alpha)}^{\infty} p(L_P)dL_P} \\ &= \frac{1}{\alpha} \int_{\text{VaR}(\alpha)}^{\infty} (L_P - \text{VaR}(\alpha))p(L_P)dL_P. \end{aligned} \quad (5.12)$$

While VaR provides information regarding what level of losses do not occur with a probability of  $1 - \alpha$ , the ES gives the expected value by which the VaR limit will be exceeded in the small number of cases with probability  $\alpha$ . They are complementary risk measures that describe the tail of the loss distribution. It indicates the average loss given a default event, i.e. when the economic capital is not sufficient to absorb the losses.

Expected shortfall takes a conditional average. As such it is a more stable estimate than VaR measures. Therefore, ES is often preferred over VaR for capital allocation. Expected shortfall is a coherent measure of risk [1, 468]. Other names for expected shortfall are expected tail loss, conditional VaR and worst conditional expectation.

## 5.4 Concentration and correlation

Apart from the individual loan characteristics, EAD, PD and LGD, correlation<sup>59</sup> and concentration are key elements that shape the portfolio loss distribution. These effects are illustrated in Figs. 5.5 and 5.6 for deterministic EAD and LGD values on the unexpected loss. While the UL is a measure of the width of the distribution, also the distribution shape and the tail fatness can depend on the correlation and concentrations. A detailed description is provided in book II.

### 5.4.1 Correlation effect on unexpected loss

Consider a homogeneous portfolio of  $N$  equal-sized loans with equal and deterministic EAD, LGD; equal PD distributions and known default

<sup>59</sup> Note that it is mathematically more correct to speak about dependence rather than on correlation [165].

correlation<sup>60</sup>  $\rho = \rho_{ij} (\forall i \neq j)$ . The expression (5.6) for the portfolio then becomes

$$\begin{aligned}\sigma_{LP} &= \frac{EAD_P}{N} \text{LGD} \sqrt{\text{PD}(1 - \text{PD})} \sqrt{\sum_{i=1}^N \sum_{j=1}^N \rho_{ij}} \\ &= EAD_P \text{LGD} \sqrt{\text{PD}(1 - \text{PD})} \sqrt{\frac{1}{N} + \rho - \frac{\rho}{N}},\end{aligned}\quad (5.13)$$

where  $EAD_P$  denotes the total portfolio exposure. The following special cases can be readily considered:

**Perfect correlation** ( $\rho = 1$ ): the unexpected portfolio loss (eqn 5.13) becomes

$$UL_P = EAD_P \text{LGD} \sqrt{\text{PD}(1 - \text{PD})}.$$

There is no diversification effect for the portfolio. The unexpected loss of the portfolio is equal to the unexpected loss of a single loan with the same characteristics.

**No correlation** ( $\rho = 0$ ): the unexpected portfolio loss (eqn 5.13) becomes

$$UL_P = \frac{EAD_P}{\sqrt{N}} \text{LGD} \sqrt{\text{PD}(1 - \text{PD})}.$$

The risk reduces inversely proportional to the square root of the number of loans in the portfolio. In general, in the case of no correlation, the unexpected loss on portfolio level is the square root of the summed squared facility unexpected losses  $UL_P = (\sum_{i=1}^N UL_i^2)^{1/2}$ . For homogeneous portfolios, this yields the factor  $1/\sqrt{N}$ .

**Perfect anticorrelation** ( $\rho = -1$ ,  $N = 2$ ): suppose that two loans are perfectly anticorrelated. This corresponds to a perfect hedge and the unexpected loss (eqn 5.13) reduces to zero. It should be noticed, however, that default correlations are typically positively correlated.

The correlation effect is depicted in Fig. 5.6. It clearly shows the significant increase in risk for high correlations.

The expression for the homogeneous portfolio also illustrates the dependence of the risk in terms of correlations and granularity. The granularity and correlation influence the unexpected loss via the 3-term expression under the

<sup>60</sup> Note that this is assumed subject to the feasibility constraint. In the case of, e.g., three loans, it is not possible that  $\rho = -1$ .

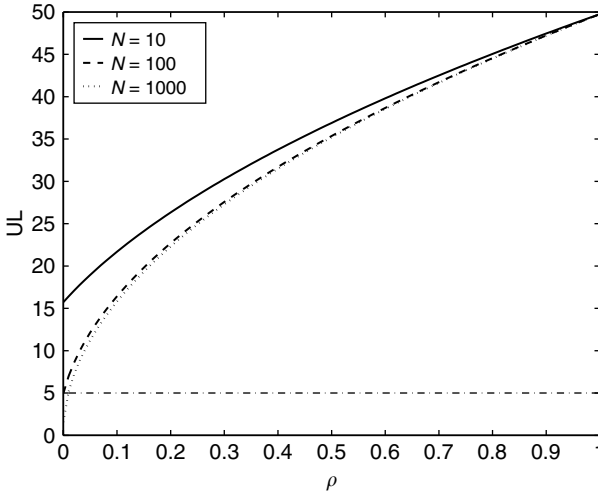

**Fig. 5.3** Impact of the PD correlation on the unexpected loss for a homogeneous portfolio of  $N = 10, 100, 1000$  loans, total exposure  $EAD_P = 1000$ , PD of 1% (BBB-range) and LGD of 50%. The expected loss is equal to 5, indicated by the horizontal dashed-dotted line.

square root in eqn (5.13). The expression consists of the granularity  $1/N$ , the correlation  $\rho$  and their cross-term  $-\rho/N$ . The impact is depicted in Fig. 5.3. The unexpected loss decreases rapidly for small  $N$ . For larger  $N$ , the reduction is less important.

### 5.4.2 Concentration effect on unexpected loss

Assume a homogeneous portfolio with  $N$  loans with  $EAD_i$  ( $i = 1, \dots, N$ ), where the individual loans have the same PD and LGD characteristics and zero PD correlation  $\rho = 0$ . The expression for the unexpected portfolio loss  $UL_P$  from (eqn 5.6) becomes

$$\begin{aligned}
 UL_P &= LGD \sqrt{PD(1 - PD)} \sqrt{\sum_{i=1}^N EAD_i^2} \\
 &= LGD \sqrt{PD(1 - PD)} \frac{\sqrt{\sum_{i=1}^N EAD_i^2}}{\underbrace{\sqrt{EAD_P^2}}_{\sqrt{HHI} = \sqrt{1/N^*}}} \sqrt{EAD_P^2} \\
 &= \frac{EAD_P}{\sqrt{N^*}} LGD \sqrt{PD(1 - PD)}, \tag{5.14}
 \end{aligned}$$

where the total portfolio exposure is denoted by  $EAD_P = \sum_{i=1}^N EAD_i$ .



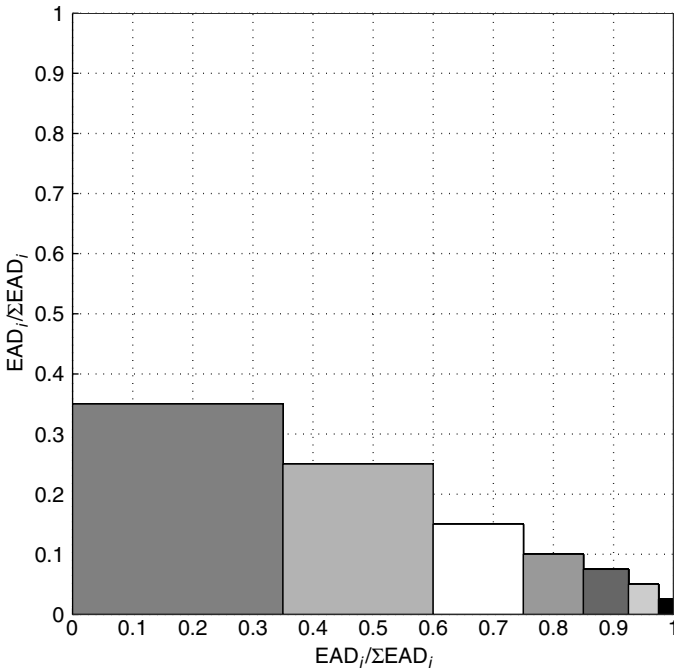
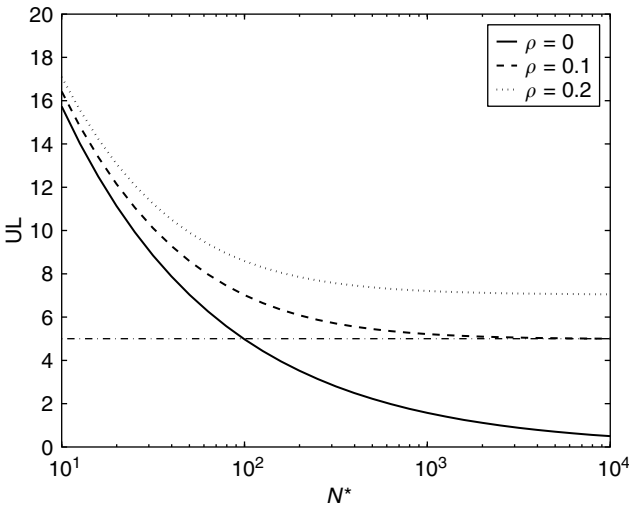

**Fig. 5.4** The Herfindahl–Hirschman index (HHI) is a standard index to measure the degree of market concentration of a particular industry in a particular geographic market [252, 253, 255, 256, 414]. The index is computed as the sum of the squared market shares compared to the squared total market share. Graphically, it compares the total area of the shaded small squares to the area of the large square. For market shares expressed as a value between 0 and 100%, the HHI ranges from 0–1 moving from a very large number of small firms to one single monopolist. The US Department of Justice considers values between 1% and 18% as moderately concentrated. For this example, the HHI is equal to 22.6%. For some applications, the market shares are scaled between 0 and 100 and the HHI ranges from 0 to 10000.

The Herfindahl–Hirschmann index, HHI (Fig. 5.4), measures the concentration effect of the portfolio:

$$HHI = \frac{\sum_{i=1}^N EAD_i^2}{(\sum_{i=1}^N EAD_i)^2} = \frac{\sum_{i=1}^N EAD_i^2}{EAD_p^2}, \quad (5.15)$$

The measure is widely used in antitrust analysis to measure the concentration in the market. A value close to zero indicates low concentration, a value close to 1 indicates high concentration. For the homogeneous portfolio, the



**Fig. 5.5** Impact of the concentration on the unexpected loss for a homogeneous portfolio with total exposure  $EAD_p = 1000$ , PD of 1% (BBB range), LGD of 50% and  $\rho = 0, 0.1$  and 0.2. The expected loss is equal to 5 indicated by the horizontal dashed-dotted line.

equivalent number of loans  $N^*$  in the portfolio is defined as

$$N^* = \frac{1}{\text{HHI}} = \frac{\sum EAD_p^2}{\sum_{i=1}^N EAD_i^2}. \tag{5.16}$$

The equivalent number of loans lies in between 1 (one single exposure) and  $N$  (equal-sized exposures). The granularity of the portfolio can be expressed as  $1/N^*$ . A fine granular exposure has a high  $N^*$ .

The impact of concentration on the unexpected loss is depicted in Fig. 5.5. It is seen that the concentration effect is especially important in absolute numbers for small concentrations. Each time the number of equivalent loans in the portfolio doubles, the unexpected loss reduces by about 30%. Of course, this holds in the case of zero PD correlation. Note that credit portfolios tend to be quite lumpy: in [107] it is reported that the largest 10% of exposures account for about 40% of the total exposure.

### 5.4.3 Combined correlation-concentration effect

Given a homogeneous portfolio of  $N$  loans with exposures  $EAD_i$  ( $i = 1, \dots, N$ ), identical PD and LGD characteristics, and PD correlation  $\rho$ .

The unexpected portfolio loss (eqn 5.6) becomes

$$\begin{aligned}
 UL_P &= LGD\sqrt{PD(1 - PD)} \sqrt{\sum_{i=1}^N \sum_{j=1}^N \rho EAD_i EAD_j + \sum_{i=1}^N (1 - \rho) EAD_i^2} \\
 &= EAD_P LGD\sqrt{PD(1 - PD)} \sqrt{\frac{1}{N^*} + \rho - \frac{\rho}{N^*}}. \tag{5.17}
 \end{aligned}$$

Comparison of this expression with the expression (5.13) for a homogeneous portfolio with equal-sized exposures indicates that, in terms of expected and unexpected loss, the portfolio with non-equal-sized exposures has the same risk as a homogeneous portfolio with the same total exposure equally spread over  $N^*$  loans. The joint effect is illustrated in Fig. 5.6. Cross-sections are reported in Figure 5.3 and 5.5.

In the case of non-homogeneous portfolios that consist of facilities with different PDs, LGDs and correlations, the expressions become more complex. It becomes more difficult to find analytical expressions to match the

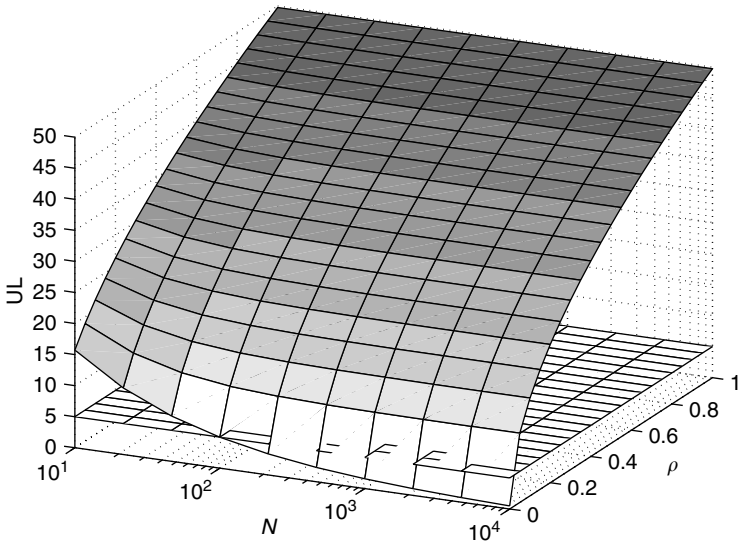

**Fig. 5.6** Impact of the PD correlation on the unexpected loss for a homogeneous portfolio with total exposure  $EAD_P = 1000$ , PD of 1% (BBB range) and LGD of 50%. The expected loss is equal to 5 indicated by the horizontal plane.

first moments of the loss distribution of the non-homogeneous portfolio to the moments of an equal-sized, homogeneous portfolio. This will be further discussed in section 5.7 where the granularity adjustment is discussed that was proposed in an earlier consultative paper on the new Basel II Capital Accord. Of course, one can always use expressions of the form (5.4) and (5.5) to calculate the unexpected loss.

#### 5.4.4 Correlations

Correlations limit the benefit of concentration reduction. Diversification means that one should take care to spread the portfolio investment across many investments that exhibit low correlation.

Correlations or dependence in general indicates that the stochastic components of the portfolio loss (eqn 5.2) exhibit a joint behavior [165]. The stochastic components or random variables are (partially) driven by common factors. Important types of dependence are known as default correlations and correlation between PD and LGD.

The default correlation reflects the property that default events are concentrated in time. There are years with many defaults during recessions and there are expansion years with a low number of defaults, as is illustrated in Fig. 3.1. Because of the low number of defaults, the measurement of PD correlations is a difficult task. Therefore, the PD correlation is often expressed in correlations that are more intuitive and easier to measure: correlations of asset or equity evolutions; correlations between rating migrations.

The dependence between PD and LGD has been reported in some empirical research on LGD modelling [16, 133, 227, 432]. In recession periods with a high number of defaults, the LGD for each default is sometimes observed to be higher. This indicates that in downturn periods, the capital buffer has to absorb two elements: a high number of defaults and high losses for each default.

Correlations also exist between market prices of non-defaulted issues, which is important in a mark-to-market portfolio explained below. The estimation and representation of correlations is a complex task because of the low number of observations and because correlation is only observed and measured indirectly. Dependence modelling is explained further in book II. An additional difficulty is that correlation tends to increase in times of stress [19, 108, 148, 164, 290].

## 5.5 Portfolio model formulations

### 5.5.1 Taxonomy

Portfolio models are widely used to analyze portfolios of assets. Their use can be motivated by regulatory purposes,<sup>61</sup> internal economic capital calculation, capital allocation, performance measurements, fund management and pricing and risk assessment of credit derivatives and securitization instruments<sup>62</sup> (e.g., collateralized debt obligations, CDOs).

#### 5.5.1.1 Classification

There is a wide variety of portfolio model formulations, each with different properties. Generally, the models are classified according to the following properties:

**Risk definitions:** The risk of the portfolio can be considered as pure default risk only or loss due to changes in market values and rating changes. Default-mode models only take into account default risk, movements in the market value or its credit rating are not relevant. Mark-to-market models consider the impact of changes in market values, credit ratings and the impact of default events. These models allow a fair market value to be given to the portfolio. Because a value has to be computed for surviving loans as well, mark-to-market models are computationally more intensive. For trading portfolios, mark-to-market models are more appropriate. For hold-to-maturity portfolios, with typically, illiquid loans, default-mode models are more applicable. When no market prices are readily available, mark-to-model approaches are a good alternative for mark-to-market approaches. Advanced models go beyond the pure credit risk and include interest rate scenarios.

**Conditional/unconditional models:** In conditional models, key risk factors (PD, LGD, ...) are explicitly conditional on macroeconomic variables. In unconditional models, the (average) key risk factors are assumed to be constant, the focus is more on borrower and facility information. In conditional models, typically the PD is made dependent on macroeconomic variables.

<sup>61</sup> The pillar 1 credit risk charges of the Basel II Capital Accord are computed based on a simplified portfolio model, while pillar 2 recommends advanced banks to check the consistency of the regulatory model results with results from internal portfolio models.

<sup>62</sup> Securitization instruments are discussed in section 1.8.4.

**Structural/reduced-form default correlations:** In structural models, correlations are explained by joint movements of assets that are possibly inferred from equity prices. Changes in the asset values represent changes in the default probability. In reduced-form models, the correlations are modelled using loadings on common risk factors like country or sector risk factors. Because dependencies are obtained in a different way, some distribution properties are different, as explained in book II.

**Distribution assumption:** Bernoulli mixture models consider the loss distribution as a mixture of binary Bernoulli variables. Poisson mixture models use a Poisson intensity distribution as the underlying distribution. For the same mean and variance, Bernoulli mixture models have fatter tails than Poisson mixture models.

**Top-down/bottom-up:** In top-down models, exposures are aggregated and considered as homogeneous with respect to risk sources defined at the top level. Details of individual transactions are not considered. Bottom-up models take into account the features of each facility and counterpart in the portfolio. Top-down models are mostly appropriate for retail portfolios, while bottom-up models are used more for firm models.

**Large/small portfolios:** Portfolio models are defined for a collection of credits. In most cases, this concerns thousands of facilities and large sample effects are important. During the last decade, structured products emerged, as discussed in section 1.8.4. Such structured products allow exchange of credit risk and are defined upon an underlying portfolio of a much smaller number of facilities compared to the whole bank's portfolio. Except when large-sample assumptions are made, the portfolio models are also applicable to structured products.

**Analytical/simulation models:** Analytical models make well-chosen simplifying assumptions on the loss distributions of the asset classes. Exposures are grouped into homogeneous asset classes on which the loss distributions are calculated and afterwards aggregated to the full portfolio level. Given the assumptions made, the results are obtained from the analytical expressions allowing fast computation. A disadvantage of these models are the restrictive assumptions that have to be made in order to obtain closed-form solutions from analytical expressions. Simulation-based models aim to approximate the true portfolio distribution by empirical distributions from a large number of Monte Carlo simulations. Because the portfolio losses are obtained from simulations, one does not have to rely upon the stringent assumptions that one sometimes has to make in analytical models. The main disadvantages are the

high computation time and the volatility of the results at high confidence levels.

A detailed mathematical description is provided in book II. In section 5.5.2 the Vasicek one-factor model is explained, an analytical default-mode model formulation that serves as the basis for the Basel II capital requirements. A related simulation based model is explained in section 5.5.3.

### 5.5.2 Vasicek one-factor model

Consider a Merton model in which the asset  $A_i$  follows a standard normal distribution [355]. The asset defaults when the asset value  $A_i$  drops below the level  $L_i$ . The default probability  $P_i$  equals  $P_i = p(A_i \leq L_i)$ .

Consider a one-factor model<sup>63</sup> with systematic factor  $\eta$  and idiosyncratic noise  $\varepsilon_i$ . The asset values are driven by both  $\eta$  and  $\varepsilon_i$  [499–501]:

$$A_i = \sqrt{\varrho}\eta + \sqrt{1 - \varrho}\varepsilon_i. \tag{5.18}$$

The stochastic variables  $A_i$ ,  $\eta$  and  $\varepsilon_i$  follow a standard normal distribution. The asset correlation  $\rho$  denotes the correlation between the assets  $A_i$  and  $A_j$ :

$$\begin{aligned} \rho[A_i, A_j] &= \mathbb{E}[(\sqrt{\varrho}\eta + \sqrt{1 - \varrho}\varepsilon_i)(\sqrt{\varrho}\eta + \sqrt{1 - \varrho}\varepsilon_j)] \\ &= \varrho\mathbb{E}[\eta^2] + \sqrt{\varrho - \varrho^2}(\mathbb{E}[\eta\varepsilon_i] + \mathbb{E}[\eta\varepsilon_j]) + (1 - \varrho)\mathbb{E}[\varepsilon_i\varepsilon_j] = \varrho. \end{aligned}$$

The asset correlation  $\varrho$  is constant between all assets  $A_i$ . It is the common factor between all considered assets that reflects, e.g., the overall state of the economy.

The unconditional default probability  $PD_i = P(\delta_{PD_i} = 1)$  is the probability that the asset value  $A_i$  drops below the threshold value  $L_i$ :

$$PD_i = P(A_i \leq L_i) = \Phi_N(L_i). \tag{5.19}$$

These unconditional probabilities can be obtained from long-term default rate statistics as reported in Fig. 3.2. Given the idealized  $PD_i = 0.20\%$  for a BBB rating, the default threshold becomes  $L_i = \Phi_N^{-1}(0.20\%) = -2.878$ .

<sup>63</sup> The one-factor model is a mathematical representation of asset evolutions. The representation here allows negative asset values, which is financially not feasible. It is often opted to define a mathematical process that reflects the basic drives in a mathematically convenient way. Positive assets can be obtained by a constant shift or transformation.

The conditional default probability given the systematic factor  $\eta$  is

$$\begin{aligned}
 \text{PD}_{C,i|\eta} &= \text{P}(A_i \leq L_i | \eta) \\
 &= \text{P}(\sqrt{1-\varrho}\varepsilon_i \leq L_i - \sqrt{\varrho}\eta | \eta) \\
 &= \text{P}\left(\varepsilon_i \leq \frac{L_i - \sqrt{\varrho}\eta}{\sqrt{1-\varrho}} \mid \eta\right) \\
 &= \Phi_N\left(\frac{L_i - \sqrt{\varrho}\eta}{\sqrt{1-\varrho}}\right). \tag{5.20}
 \end{aligned}$$

Substitution of eqn 5.19 into eqn 5.20 yields

$$\text{PD}_{C,i|\eta} = \Phi_N\left(\frac{\Phi_N^{-1}(\text{PD}_i) - \sqrt{\varrho}\eta}{\sqrt{1-\varrho}}\right). \tag{5.21}$$

Given that the systematic risk factor  $\eta$  follows a standard normal distribution, the expression (5.21) allows computation of a worst case PD at the  $(1 - \alpha)$  confidence level given the systematic risk factor.

$$\text{PD}_{C,i|\eta}(1 - \alpha) = \Phi_N\left(\frac{\Phi_N^{-1}(\text{PD}_i) - \sqrt{\varrho}\Phi_N^{-1}(1 - \alpha)}{\sqrt{1-\varrho}}\right). \tag{5.22}$$

This expression is the conditional default probability associated with the Vasicek one-factor model [499–501].

For a portfolio with  $N$  assets, unit exposure and 100% LGD, the conditional default probability of  $k$  defaults is

$$\begin{aligned}
 P\left(L_P = \frac{k}{N} | \eta\right) &= \binom{N}{k} \text{PD}_{C|\eta}^k (1 - \text{PD}_{C|\eta})^{N-k} \\
 &= \binom{N}{k} \Phi_N\left(\frac{\Phi_N^{-1}(\text{PD}_i) - \sqrt{\varrho}\eta}{\sqrt{1-\varrho}}\right)^k \left(1 - \Phi_N\left(\frac{\Phi_N^{-1}(\text{PD}_i) - \sqrt{\varrho}\eta}{\sqrt{1-\varrho}}\right)\right)^{N-k}.
 \end{aligned} \tag{5.23}$$

The unconditional default probability is obtained by marginalizing over  $\eta$

$$\begin{aligned}
 \text{P}(L_P = \frac{k}{N}) &= \int_{-\infty}^{+\infty} \binom{N}{k} \Phi_N\left(\frac{\Phi_N^{-1}(\text{PD}_i) - \sqrt{\varrho}\eta}{\sqrt{1-\varrho}}\right)^k \\
 &\quad \times \left(1 - \Phi_N\left(\frac{\Phi_N^{-1}(\text{PD}_i) - \sqrt{\varrho}\eta}{\sqrt{1-\varrho}}\right)\right)^{N-k} d\Phi_N(\eta).
 \end{aligned}$$



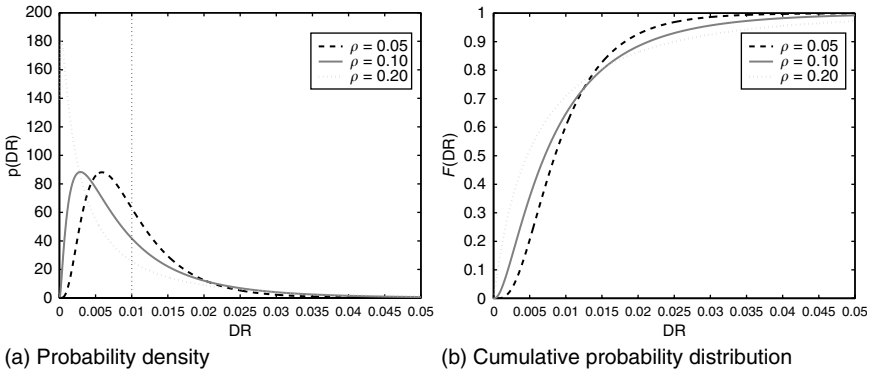

**Fig. 5.7** Probability density function and cumulative probability distribution function of the portfolio Default Rate (DR) for the Vasicek one-factor model. The PD of 1% is indicated by the vertical line. The higher the asset correlation, the fatter is the tail and the more likely become very high default rates.

For a very large portfolio, the cumulative distribution function becomes [499–501]

$$P(L_P \leq 1 - \alpha) = \Phi_N\left(\frac{1}{\sqrt{\varrho}}(\sqrt{1 - \varrho}\Phi_N^{-1}(1 - \alpha) - \Phi_N^{-1}(\text{PD}))\right),$$

where  $\alpha$  indicates the confidence level. The proportional loss  $L_P$  denotes the default rate DR. The limiting loan loss distribution has corresponding density function

$$p(\text{DR}) = \sqrt{\frac{1 - \varrho}{\varrho}} \exp\left(\frac{1}{2}\Phi_N^{-1}(\text{DR}) - \frac{1}{2\varrho}\left(\Phi_N^{-1}(\text{PD}) - \sqrt{1 - \varrho}\Phi_N^{-1}(\text{DR})\right)^2\right)$$

with mean value  $\mathbb{E}[p(\text{DR})] = \text{PD}$ , median value  $\Phi_N((1 - \varrho)^{-1/2}\Phi_N^{-1}(\text{PD}))$  and mode  $\Phi_N((1 - \varrho)^{1/2}/(1 - 2\varrho)\Phi_N^{-1}(\text{PD}))$  for  $\varrho < 1/2$ . This limiting loan loss distribution is highly skewed. Its probability density and cumulative distribution are depicted in Fig. 5.7. For very large portfolios the uncertainty of the binomial distribution reduces to zero and the worst case default rate at the  $1 - \alpha$  confidence level is obtained from eqn 5.22. Conditional on the systematic factor  $\eta$ , the expected default rate or conditional PD is

$$\text{PD}_{C|\eta} = \Phi_N\left(\frac{\Phi_N^{-1}(\text{PD}) - \sqrt{\varrho}\eta}{\sqrt{1 - \varrho}}\right). \tag{5.24}$$

Apart from capital calculations, this formula has also been applied to map TTC ratings with average PD to PIT ratings with  $\text{PD}_{C|\eta}$  depending on

the time-varying economic condition represented by  $\eta$ . An illustration is available from (eqn 3.1) in section 3.6.3 [3].

### 5.5.3 Simulation-based models

The advantage of simulation-based models is that one can “more easily” take into account many dependencies via numerical computations. Consider a mark-to-market model in combination with a Merton approach for default prediction. A simulation-based model then works as follows:

1. Given the current rating of the assets, the migration matrices (with PD), the LGD distribution, the EAD (or its distribution) and the asset correlations.
2. Generate a simulation of correlated asset realizations.
3. Compute for each facility the migration events.
4. Compute the loss realized with each migration. In the case of default, the loss is computed via a simulation from the LGD distribution that can be conditionally dependent on the macroeconomic situation.
5. Compute the full portfolio loss aggregating the losses of the assets.

This scheme is then realized for many simulations and the empirical distribution is obtained. A flow chart of the simulation scheme is depicted in Fig. 5.8. In the next sections, the main elements of the simulation framework are discussed.

#### 5.5.3.1 Correlated asset realizations

Consider the case of a one-factor model for a portfolio with homogeneous asset correlation  $\varrho$ . The standardized returns of the assets are obtained as

$$r_i = \sqrt{\varrho}\eta + \sqrt{1 - \varrho}\varepsilon_i, \quad (5.25)$$

where  $\eta$  and  $\varepsilon_i$  are simulations from independent standard normal distributions. The systematic part of the asset returns is equal to  $\sqrt{\varrho}\eta$ , while the asset or firm-specific part  $\sqrt{1 - \varrho}\varepsilon_i$  is also known as the idiosyncratic part.

Other applications have non-homogeneous asset correlations. Counterparts exhibit a higher or lower dependence depending on whether they operate in the same industrial sector or geographic region. Let  $\mathbf{Q}_\varrho \in \mathbb{R}^N$  be the correlation matrix of the asset returns  $r_i$ , with  $q_{\varrho,ij} = \text{corr}(r_i, r_j)$  ( $i, j = 1, \dots, N$ ). The Cholesky factorization  $\mathbf{Q}_\varrho = \mathbf{R}^T \mathbf{R}$  is a generalization of the square root  $\sqrt{\varrho}$  in eqn 5.25. The matrix  $\mathbf{R}$  is an upper triangular matrix

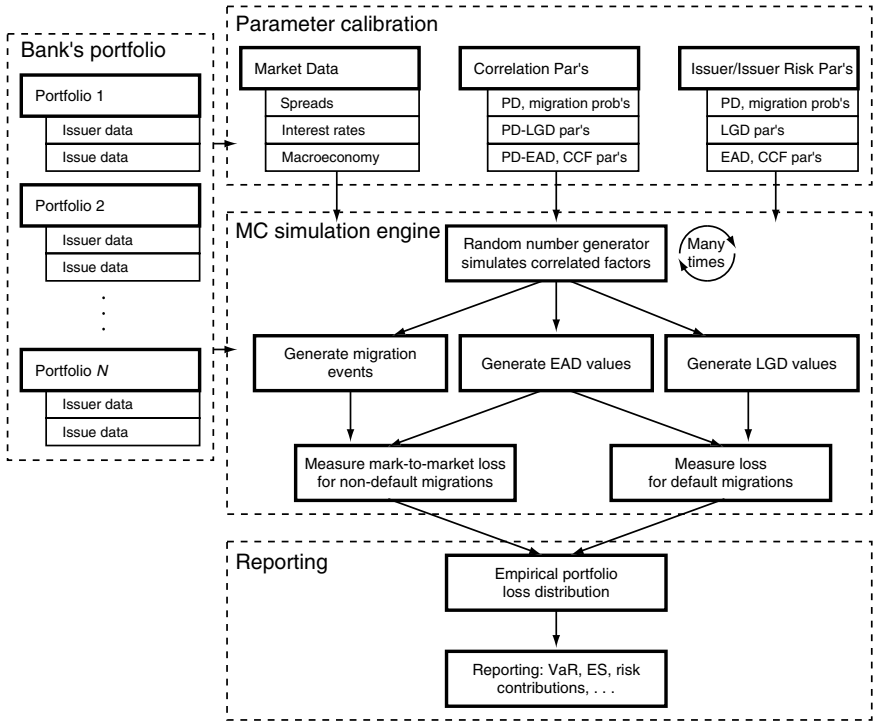

**Fig. 5.8** Flow chart of a simulation framework for a credit risk portfolio model. The Monte Carlo engine generates simulated correlated asset realizations. For each asset, the migration is calculated and the resulting loss is determined either in a mark-to-market or default-mode setup. These individual gains or losses are aggregated to the portfolio loss. The procedure is repeated many times to obtain the empirical loss distribution. Apart from the technicalities of the simulation engine itself, an important aspect of the portfolio model design is the model calibration. Simple implementations apply only correlations between PD rating migrations, advanced models take into account PD-LGD, PD-EAD correlations and even dependencies with spread evolutions and interest rates. The latter is not depicted on the graph, but can be taken into account similarly as the PD-LGD dependence.

such that  $\mathbf{Q}_Q = \mathbf{R}^T \mathbf{R}$ . An example of the Cholesky factorization is given in the Appendix. The correlated asset returns are then generated from

$$r_i = \mathbf{R}^T \boldsymbol{\eta} + \sqrt{1 - \varrho_i} \varepsilon_i, \tag{5.26}$$

with  $\varrho_i = \sum_{j=1}^i \mathbf{R}(j, i)^2$ . The vector  $\boldsymbol{\eta} \in \mathbb{R}^N$  of dependent factors and the idiosyncratic noise  $\varepsilon_i$  are simulations from independent standard normal distributions. In the case of non-homogeneous asset correlations, it is computationally not straightforward to compute all asset correlations for large portfolios. Indeed, for  $N$  assets the correlation matrix has  $O(N^2)$  correlations

to be calculated and the Cholesky decomposition requires  $O(N^3)$  computations. An alternative approach, used by CreditMetrics [225], is to regress the asset return of facility  $i$  on a number of  $n \ll N$  factors  $f_j$  ( $j = 1, \dots, n$ ):

$$r_i = w_{i1}f_1 + w_{i2}f_2 + \dots + w_{in}f_n + \sigma_i\varepsilon_i, \tag{5.27}$$

where the factors  $f_j$  are standardized realizations of sectorial and geographical risk factors. The factor loadings  $w_{ij}$  ( $j = 1, \dots, n$ ) represent the weight of factor  $j$  to explain the assets returns  $r_i$ . The loading can be obtained from least-squares regression (see book II), where one typically imposes that  $0 \leq w_{ij} \leq 1$  or  $-1 \leq w_{ij} \leq 1$ . The variance  $\sigma_i^2$  is obtained from the unit variance constraint on the asset return  $r_i$ :

$$\sigma_i = \sqrt{1 - \sum_{k=1}^b \sum_{l=1}^n w_{ik}w_{il}Q_{f_k,f_l}}$$

The asset correlation between two assets  $i$  and  $j$  is then obtained as

$$\rho_{ij} = \begin{bmatrix} w_{i1} \\ w_{i2} \\ \vdots \\ w_{in} \end{bmatrix}^T \begin{bmatrix} 1 & Q_{f_1,f_2} & \dots & Q_{f_1,f_n} \\ Q_{f_2,f_1} & 1 & \dots & Q_{f_2,f_n} \\ \vdots & \vdots & \ddots & \vdots \\ Q_{f_n,f_1} & Q_{f_n,f_2} & \dots & 1 \end{bmatrix} \begin{bmatrix} w_{j1} \\ w_{j2} \\ \vdots \\ w_{jn} \end{bmatrix}. \tag{5.28}$$

Based on the Cholesky decomposition of the factor correlation matrix  $[Q_{f_k,f_l}]_{k,l=1:n}$ , one needs to store the factor loadings  $w$  for each asset  $i$  and the idiosyncratic variance  $\sigma_i^2$ . The factor correlations can be obtained from a historical time series on sector returns or country returns, where one can emphasize stressed periods or choose the dependence together with the financial experts. One can then generate a simulation of correlated factors from the Cholesky decomposition and a simulation for the idiosyncratic noise  $\varepsilon_i$  for all assets  $i = 1, \dots, N$ . The correlated asset returns are then obtained from eqn 5.27.

### 5.5.3.2 Migration events

The correlated asset realization  $r_i$  generated from eqns 5.25–5.27 follows a standard normal distribution. Based upon the current rating  $R_t$ , e.g., BBB, the 1-year migration matrix yields the conditional migration probabilities

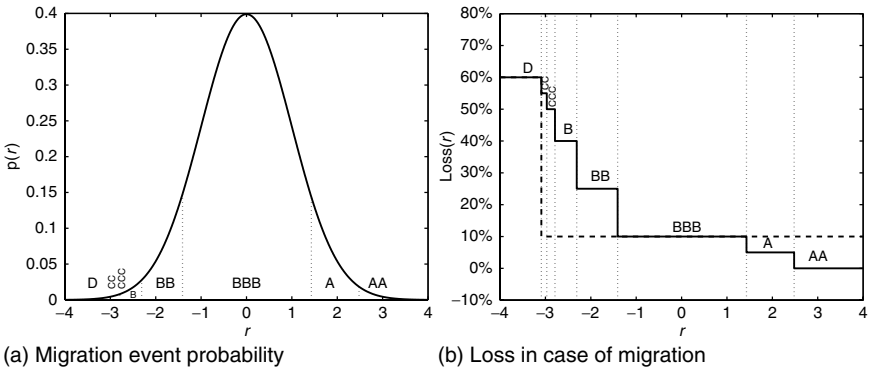

**Fig. 5.9** Migration events (left) and resulting losses (right) for a BBB company depending on the realization of  $r$ . For large  $r$ , an upgrade to A or AA is possible. For very low realizations of  $r$ , the company defaults. In 84% of the cases, the rating remains stable and the losses are zero. The right pane indicates the resulting losses in the case of a migration. The exact value of the loss in the case of migration depends on facility properties and spread structure.

$P(\text{AAA}|\text{BBB}), P(\text{AA}|\text{BBB}), \dots, P(\text{CCC}|\text{BBB})$  and  $P(\text{D}|\text{BBB})$  from BBB to the rating classes<sup>64</sup> AAA, AA,  $\dots$ , CCC and the default state D, respectively.

Given the standard normal asset return  $r_i$ , the next rating is then assigned as follows:

$$\left\{ \begin{array}{ll} 0 < \Phi_N(r_i) \leq P(\text{D}|\text{BBB}) & \Rightarrow R_{t+1} = \text{D} \\ P(\text{D}|\text{BBB}) < \Phi_N(r_i) \leq P(\text{D}|\text{BBB}) + P(\text{CCC}|\text{BBB}) & \Rightarrow R_{t+1} = \text{CCC} \\ \vdots & \vdots \\ 1 - P(\text{AAA}|\text{BBB}) < \Phi_N(r_i) \leq 1 & \Rightarrow R_{t+1} = \text{AAA}. \end{array} \right. \quad (5.29)$$

This is done for all assets realizations, which yields the ratings for the next year of all assets. Figure 5.9a illustrates the probabilities for the migration matrix of Table 3.3.

The estimation of the migration matrix (including default rates) is an important element in the migration matrix. One may even choose to put some migration probabilities equal to zero in cases where one considers it impossible or unrealistic for the bank to hold capital for such events. Such examples can result from country-ceiling effects or rating-support floors

<sup>64</sup> Observe that one may also consider larger migration matrices including rating modifiers. The main elements in the trade-off are accuracy of the model results, computation cost, data availability and reliability for model calibration; and consistency across different sectors. The 1-year migration matrix is chosen here consistent with a 1-year horizon for the loss calculation. If appropriate, one may also use multiple-year migration matrices estimated from rating migrations or derived from the 1-year migration matrix under the Markov assumption.

from mother or state intervention. Advanced systems are equipped with flexible limits based on the rating of the country and/or mother.

Migration matrices estimated from historical migrations may suffer from statistical noise or may not be meaningful financially speaking. Statistical results indicate that except for the main diagonal elements, the uncertainty on estimated elements can be very high due to the limited number of observations. Typical approaches to obtain coherent migration matrices are smoothing per row the left and right part of the diagonal or the estimation of consistent migration generator matrices [225, 279].

### 5.5.3.3 Mark-to-market losses

A zero-coupon bond does not pay any coupon and repays the face value  $F$  at the maturity date  $M$ . The bond price  $P$  relates the yield  $y$  to the face value and maturity:

$$P = \frac{F}{(1 + y)^M}. \quad (5.30)$$

When discounting the face value at the yield  $y$ , the present value of the face value  $F$  equals the bond price  $P$ . Given the bond price  $P$ , face value  $F$  and maturity  $M$ , the yield is obtained from eqn 5.30 as  $y = (F/P)^{1/M} - 1$ . For different maturities, different yields are obtained. The relation between yield and maturity is referred to as the term structure of interest rates. The yield curve has typically an upward trend, as depicted in Fig. 1.6. The yield for a zero-coupon bond is called the spot rate.

The cash flows from other bond types can be considered as a combination of zero-coupon bonds with different maturities. Consider now a fixed-coupon bond with face value  $F$ , coupon  $C$ , (remaining) maturity  $M$  and price  $P$ . For a given term structure of yields  $y_1, y_2, \dots, y_M$ , the relation<sup>65</sup> between bond prices, yields, coupons, face value and maturity is

$$P_M = \sum_{i=1}^{M-1} \frac{C}{(1 + y_i)^i} + \frac{F + C}{(1 + y_M)^M}. \quad (5.31)$$

<sup>65</sup> For simplicity, it is assumed here that the previous coupon has just been paid and that annual coupons are paid. Formulas for other coupon-payment frequencies have a similar form. When there is more time between the previous coupon payment, one may also take into account the accrued interest, which is the time-weighted proportion of the next coupon. Prices without accrued interest are clean prices, with accrued interests they are called dirty prices. See [173, 291] for more details.

### 302 Portfolio models for credit risk

The iterative estimation of  $y_i$  based upon  $P_i$ ,  $F$ ,  $C$  and yields with shorter maturity  $y_1, \dots, y_{i-1}$  is called a bootstrapping procedure. From the calculated yield/maturity relation the theoretical spot rate curve is obtained. It is referred to as the term structure of interest rates. In practice, the calculation becomes more complex because there are more observations at the same maturity trading at different yields and because prices are not available for all maturities. More details on yield curves and modelling can be found in [173, 376].

The forward rate  $f_{m,M}$  is the rate at a future date  $m$  for remaining maturity  $M - m$ . It indicates the rate that will be charged in the future for a given remaining maturity. The forward rate is related to the spot rate (Fig. 5.10)

$$\begin{aligned}y_1 &= f_{0,1} \\y_M &= y_m f_{m,M} \\y_M &= y_1 f_{1,M}.\end{aligned}$$

The fair value  $V$  of the bond next year (at the end of the 1-year horizon for the portfolio modelling evaluation) is calculated as follows

$$V = \sum_{t=2}^{M-1} \frac{C}{(1 + f_{1,t})^{t-1}} + \frac{F + C}{(1 + f_{1,M-1})^{M-1}},$$

where  $f_{1,t}$  is the 1-year forward rate for maturity  $t$  and remaining maturity  $t - 1$ . As the forward rate increases with rating downgrades, each

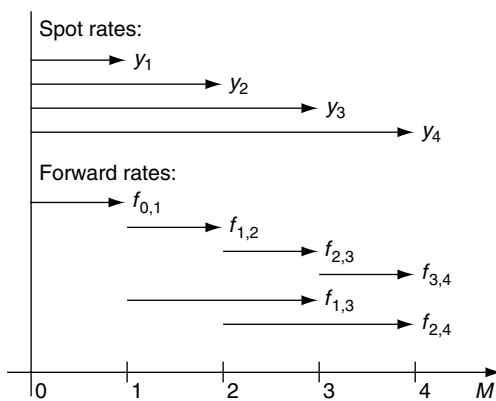

**Fig. 5.10** Spot and forward rates for different maturities. The forward rates are illustrated for various start dates and remaining maturities. The forward rate  $f_{n,m}$  is related to the spot rates  $y_n$  and  $y_m$  via  $1 + y_m = (1 + y_n)(1 + f_{n,m})$ .

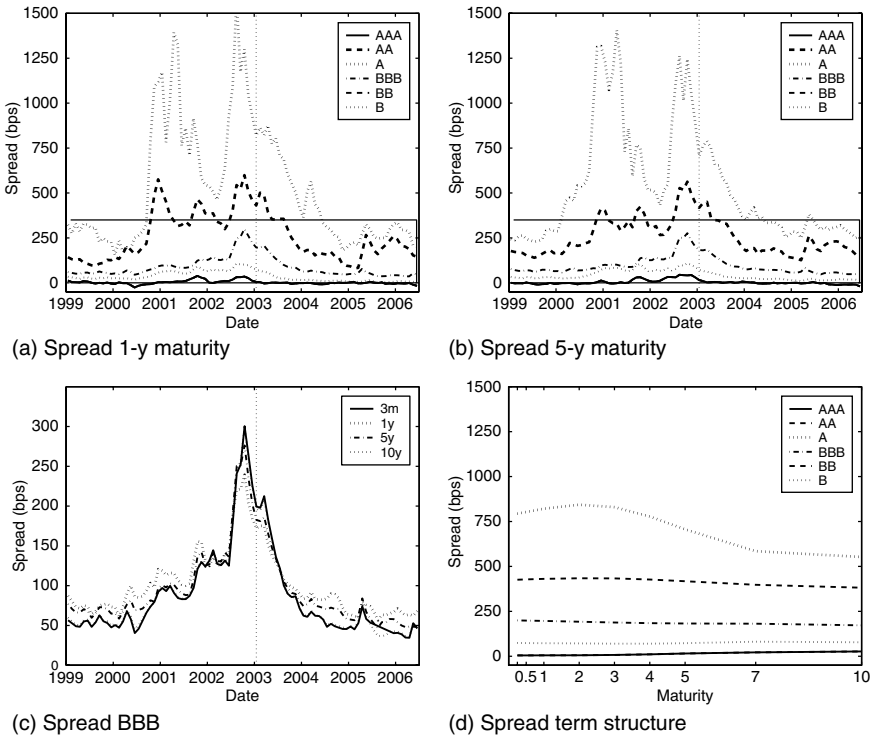
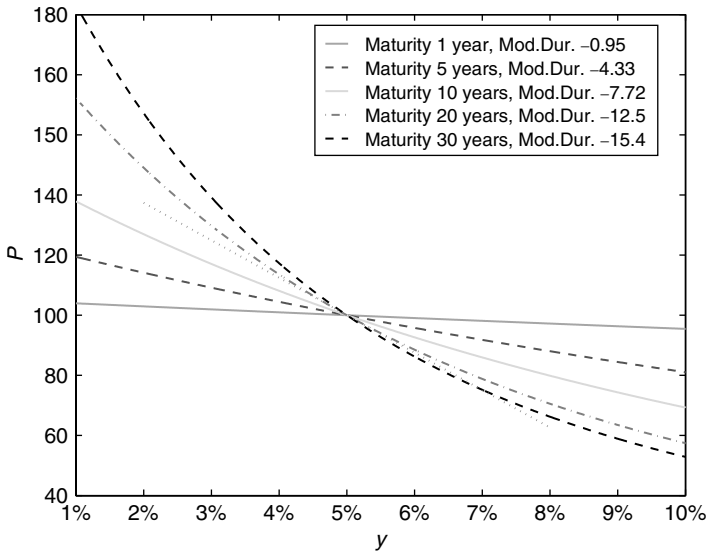

**Fig. 5.11** Monthly average spread values for USD denominated US firm bonds from January 1999 till June 2006 (source: CreditDelta). The top 2 graphs report the spreads for AAA-, AA-, A-, BBB-, BB- and B-rated bonds for a maturity of 1 and 5 years, respectively. The bottom left graph (c) illustrates the evolution of the spreads for a BBB rating for various maturities. The bottom right graph depicts the spread term structure for January 2003.

rating downgrade will reduce the fair value  $V$ , whereas a rating upgrade will increase the fair value  $V$ . An indicative shape of the procentual losses in the case of migration is depicted in Fig. 5.9b. Figure 5.11 depicts the bond spreads for different rating grades. The spread is reported for USD denominated US firm bonds. It is observed that the risk premium charged for different rating grades is highly volatile. The volatility of spreads and the corresponding impact on the bond prices is known as spread risk. Spread risk models are on the borderline between market and credit risk models. The time horizon varies from 10 days to 1 year.

Bonds with longer maturity are more sensitivity to rate changes because the mark-to-market losses of bonds with longer maturity are more sensitive to forward and yield changes. For a bond with face value  $F = 100$ , maturity





**Fig. 5.12** Illustration of bond price  $P$  sensitivity to the yield  $y$  for a bond with face value 100, coupon rate 5% and different maturities. The modified duration is reported at yield  $y = 5\%$  and its linear approximation reported for a maturity  $M = 20$ .

$M$  and fixed yearly coupon of  $C = 5\%$ , the price  $P$  when discounting future cash flows at a constant yield  $y$  is illustrated in Fig. 5.12.

Note the increasing sensitivity for a longer maturity. The modified duration (eqn 1.1) expresses the sensitivity of the price  $P$  to the yield  $y$ , relative to the current price  $P$ . For smaller (remaining) maturities, the prices are pulled to the face value and the price sensitivity is small. Note that for larger yield changes, the convex relation becomes more important. The price–yield function is said to have positive convexity, which is due to the exponential discounting formula.

The bond market has many different bond types, e.g., bonds with semi-annual fixed coupons, bonds with floating coupon rates, callable bonds, etc. For each of these bond types, an appropriate pricing and market sensitivity are determined. Loans may have similar features as discussed in section 1.8. More complex bonds may include option characteristics. An overview of the pricing and risk analysis of bonds is available in [173, 291].

### 5.5.3.4 Default losses

In the event of default, one needs to assign the loss. In the case of default mode models, this is the only case a loss is registered. In the case of a

fixed average or stressed LGD, the loss is easily determined. In the more general case, an LGD distribution needs to be or has been estimated, and a random LGD value is drawn from the estimated distribution in the case of a default event. Typically, a beta distribution is used to fit LGD distributions. Advanced approaches use kernel density estimation methods to fit bimodal LGD distributions and/or combine discrete beta or kernel distributions with discrete distributions for the case of 0% or 100% LGD. In the case of beta distributions, the parameters can be obtained by fitting the mean and variance of the beta distribution on the empirical mean and variance of the observed LGDs. This is particularly interesting because these measures are often reported, e.g., in rating agencies reports.

Given the cumulative LGD-distribution  $\Phi_{\text{LGD}}$ , the loss in the case of a default is randomly obtained as follows:

$$\text{LGD} = \Phi_{\text{LGD}}^{-1}(\Phi_N(x)),$$

with  $x$  a standard normal distributed stochastic variable,  $\Phi_N$  the cumulative standard normal distribution and  $\Phi_{\text{LGD}}^{-1}$  the inverse of the cumulative LGD-distribution. Stochastic LGDs are more realistic as the LGD may be dependent on many sources. The use of stochastic LGDs increases the computational requirements and the additional uncertainty increases the tail fatness of the loss distribution. A dependence with the default risk factors is introduced when  $x = \sqrt{\rho'}\eta + \sqrt{1 - \rho'}\varepsilon'$ . Instead of varying the LGD, one can also reduce the collateral value for secured facilities [201, 202].

#### 5.5.4 Model calibration

Although there exist different model formulations, the differences on the resulting risk measures are reduced by a proper calibration, as is explained, e.g., in [124]. Apart from the methodology choices and the IT implementation of the (Monte Carlo) calculation engine, the calibration is an important aspect of the setup of a portfolio model [82, 124, 196, 212, 313].

The calibration concerns the decision on the key risk parameters. Some parameters, like default, loss and exposure risk are relatively easy to calibrate. This work needs to be done anyway for banks that adopt the Basel II advanced internal-ratings-based approach. The correlation and dependence are only observed indirectly. The calibration of these parameters has an important impact on the tail distribution and requires special care and understanding. In complex portfolio models, the calibration task requires a careful selection of each parameter and verification of the global result. The latter is

**Table 5.2** Comparison of the basic portfolio model formulations.

	KMV PM	CreditMetrics	PRT	CPV Macro	CreditRisk <sup>+</sup>
Originator	KMV	JP Morgan	S&P <sup>66</sup>	McKinsey	Credit Suisse
Documentation	[84]	[225]	[131]	[352]	[121]
Date	2001	1997	2003	1998	1997
Risk type	Default loss	$\Delta$ Market value	$\Delta$ Market value	$\Delta$ Market value	Default loss
Credit events	Defaults	Defaults migration	Defaults migration spread	Defaults migration	Defaults
Risk driver	Asset value	Asset value (country/industry)	Asset value (country/industry)	Macro economic factors	Sector default intensities
PD Corr.	Asset value factor model	Equity value factor model	Asset value factor model	Macro-economic factor model	Default intensity model
LGD Distr.	Beta	Beta	Beta	Random	Constant
PD/LGD Corr.	No	No	Yes	No	No
Calculation	Monte Carlo simulation	Monte Carlo simulation	Monte Carlo simulation	Monte Carlo simulation	Analytical solution

achieved via benchmarking and backtesting. The literature on the backtesting of portfolio models is rather limited and is still an area of research.

## 5.6 Overview of industry models

Table 5.2 summarizes the basic features of some well-known and popular portfolio model formulations. Each of these models and its possible extensions are discussed individually.

### 5.6.1 CreditMetrics

This model considers an asset value process like eqns 5.25 and 5.27. Default or migrations occur when the firm’s asset value exceeds one of the critical threshold values (eqn 5.29). The asset value process is assumed to be

<sup>66</sup> The model formulation has been commercialized by S&P.

dependent upon industrial sector and regional factors  $\phi_j$  ( $i = 1, \dots, J$ ):

$$\begin{aligned} r_i &= R_i \eta_i + \sqrt{1 - R_i^2} \varepsilon_i, \\ &= R_i \left( \sum_{j=1}^J w_{ij} \phi_j \right) + \sqrt{1 - R_i^2} \varepsilon_i, \end{aligned} \quad (5.32)$$

with  $\eta_i = \sum_{j=1}^J w_{ij} \phi_j$  the firm's composite factor and  $\varepsilon_i$  the firm-specific effect or idiosyncratic noise part. Compared to eqn 5.18, one has  $R_i = \sqrt{\bar{\rho}}$ , the value  $R_i^2$  denotes how much of the asset return volatility  $r_i$  is explained by the volatility of the composite factor  $\eta_i$ . It measures the correlation with the systematic influences of the industry and country indices  $\psi_j$ . The parameters  $w_{ij}$  measure the factor loadings.

Conditional upon  $z = \eta_i$ , the default probability becomes

$$p_i(z) = \Phi_N \left( \frac{\Phi_N^{-1}(\text{PD}_i) - R_i z}{\sqrt{1 - R_i^2}} \right). \quad (5.33)$$

The above expression allows application of different scenario's of the industry and country factors  $\psi_j$  and evaluation of the default risk. Scenario stress testing is performed by selecting stress evolutions of the country and sector indices.

The simulation tool is not only default-mode oriented, but also mark-to-market. Mark-to-market price changes and losses are triggered by rating changes. The random generator generates correlated transitions dependent on the correlated assets (eqn 5.32) that would correspond in default mode to the loss distribution (eqn 5.22). Given the correlated transitions, the market losses are calculated. For (simulated) default events, the recovery can be drawn from a beta distribution and the losses are obtained. The LGDs are assumed not to be correlated with each other or with the default probabilities or other risk factors. The exposure at default is obtained via average exposures, or using loan-equivalent average exposures for more complex instruments (swaps, options, ...).

### 5.6.2 Portfolio Manager

KMV's Portfolio Manager is similar to the CreditMetrics model using a default-mode approach. It relies on a multivariate normal distribution of the

asset returns:

$$\begin{aligned}
 r_i &= R_i \eta_i + \sqrt{1 - R_i^2} \varepsilon_i, \\
 &= R_i \left( \sum_{j=1}^{J_C} w_{C,ij} \phi_{C,j} + \sum_{j=1}^{J_S} w_{S,ij} \phi_{S,j} \right) + \sqrt{1 - R_i^2} \varepsilon_i, \quad (5.34)
 \end{aligned}$$

whereby the one-factor  $\eta_i$  is composed of sector and country factor indices  $\phi_{S,j}$  and  $\phi_{C,j}$  reflecting the  $J_S$  and  $J_C$  sectors and countries in which the firm operates. The factor loadings satisfy  $\sum_{j=1}^{J_C} w_{C,ij} = 1$  and  $\sum_{j=1}^{J_S} w_{S,ij} = 1$ . The parameter  $R_i$  is obtained from a regression of the asset values  $r_i$  onto the factor  $\eta_i$ .

The default probability is not estimated from the rating category, but from the expected default frequencies (EDF) resulting from a Merton-type model (see section 4.3.1.1). The loss distribution is obtained from a beta distribution as in CreditMetrics and also the other model specificities are similar.

### 5.6.3 Portfolio Risk Tracker

Portfolio Risk Tracker (PRT) is a recent ratings-based model with a similar structure as CreditMetrics. It has been commercialized by Standard & Poor's. As it is a more recent model, new advanced functions are included. Apart from static computations that report loss distributions at the end of the time horizon, intermediate results at fixed time intervals can also be provided. It additionally includes stochastic interest rates, such that interest-rate-sensitive instruments like floating rate notes can be taken into account in the loss distribution computation without using loan equivalence. Stochastic spreads are also included, which is a novelty compared to the other models. In this sense, this portfolio model is able to capture default risk, migration risk and spread risk.

Other new elements include different ways to choose correlations, modelling of sovereign ceilings, correlations between PD and LGD and the possibility to include equities, Treasury bonds and interest rate options.

### 5.6.4 Credit Portfolio View

Credit Portfolio View (CPV) [518, 519] is a conditional macroeconomic model used by the international management consulting firm McKinsey &

Company to support its projects in credit risk management. It is a simulation-based and ratings-based portfolio model in which the default and migration probabilities depend upon macroeconomic variables  $x$  like Gross Domestic Product growth, inflation, interest rates, savings rates and unemployment.

The whole portfolio is subdivided into  $N_s$  segments that correspond to sectors and or geographic zones. In each segment  $s$  and at time index  $t$ , the default rate  $\text{PD}_{s,t} \in [0, 1]$  is dependent on a general macroeconomic index  $y_{s,t} \in \mathbb{R}$  via the logistic link function

$$\text{PD}_{s,t} = \frac{1}{1 + \exp(-y_{s,t})} \quad \text{and} \quad y_{s,t} = -\ln(1/\text{PD}_{s,t} - 1).$$

The logistic link function maps a real-valued variable into the interval  $[0, 1]$ :  $y_{s,t} \rightarrow \infty$ ,  $\text{PD}_{s,t} \rightarrow 1$  and  $y_{s,t} \rightarrow -\infty$ ,  $\text{PD}_{s,t} \rightarrow 0$ .

The macroeconomic index  $y_{s,t}$  itself is obtained based upon the macroeconomic variables  $x_{i,t}$  via

$$y_{s,t} = \beta_{s,0} + \sum_{i=1}^{N_x} \beta_{s,i} x_{i,t} + \varepsilon_{s,t},$$

where the macroeconomic variables are chosen to follow an autoregressive (AR) process

$$x_{i,t} = \alpha_{i,0} + \sum_{j=1}^{N_T} \alpha_{i,j} x_{i,t-j} + e_{i,t}.$$

The errors  $\varepsilon_{s,t}$  and  $e_{i,t}$  are identically independently distributed (i.i.d.) normal error terms that can be correlated among the macroeconomic variables and sectors, respectively. Typically, one uses  $N_T = 2$  lags in CPV; although there exist many other techniques to design linear autoregressive models. One may consult, e.g., the books [89, 97, 235, 341, 403, 469] or many academic papers on this topic like [405, 491] that contain introductions on linear and non-linear financial time series analysis.

Each segment default rate  $\text{PD}_{s,t}$  is compared to the average (unconditional) default rate  $\overline{\text{PD}}_s$ . One defines the risk index  $r_{s,t} = \text{PD}_{s,t}/\overline{\text{PD}}_s$ . The segment is in recession when  $r_{s,t} > 1$  and in expansion when  $r_{s,t} < 1$ . The risk index determines the migration matrix

$$M_{s,t}(i, j) = \overline{M}_s(i, j) + (r_{s,t} - 1)\Delta M_s(i, j),$$

which in turn determines the mark-to-market loss due to migrations. The conditional migration matrix  $M_{s,t}$  consists of an average part  $\bar{M}_s$  and of a conditional part  $(r_{s,t} - 1)\Delta M_s$ . The shift matrix  $\Delta M_s$  satisfies  $\Delta M_s(i, j) \geq 0$  for  $i < j$  and  $\Delta M_s(i, j) \leq 0$  for  $i > j$  as upward migrations become more plausible during expansions, whereas downward migrations become less plausible. The CPV algorithm ensures that  $M_{s,t}$  is a stochastic matrix at all times with positive elements and rows summing up to one.

There exist two model formulations: the CPV macro and CPV direct model. The CPV macro model was developed first and works as follows. First, it generates (possibly correlated) noise sequences  $e_{i,t+1}, e_{i,t+2}, \dots$  and  $\varepsilon_{s,t+1}, \varepsilon_{s,t+2}, \dots$  for  $i = 1, \dots, N_x$  and  $s = 1, \dots, N_s$ . The time indices can, e.g. be yearly data and if one wants to simulate over a 5-year prediction horizon, one uses 5 lags for each sequence. For each simulation, one computes the macroeconomic indices, segment default rates and risk indices. The 5-year conditional migration matrix is then obtained as the product of the conditional migration matrices. Simulating many sequences  $e$  and  $\varepsilon$  yields the distribution of migrations and default probabilities for any initial rating. Together with an assumption on the LGD, one can approximate the average loss distribution. Observe, however, that the model returns aggregate default rates and not obligor-specific default probabilities. The model is a top-down model, while other models start bottom-up from obligor- and facility-specific data.

Although the macroeconomic variables are intuitive and relatively easy to obtain, the model calibration of the CPV macro model can be a complex task as many parameters have to be estimated, while data may not always be readily available. Indeed, one has to estimate the parameters  $\alpha_{i,j}, \beta_{s,j}$  given a time series of the macroeconomic variables  $x_{i,t}$  and default rates  $PD_{s,t}$ . Especially the latter may be less easy to obtain. As an alternative to the CPV macro, the CPV direct formulation has been developed to avoid all the difficulties of the calibration of the CPV macro model. CPV direct allows to obtain the segment specific default rates directly drawn from a gamma distribution for which the calibration can be done via the method of moments as explained in book II.

This CPV model description has to be considered as a general framework. It is tailored to the client's needs in the implementation.

### 5.6.5 CreditRisk<sup>+</sup>

The original CreditRisk<sup>+</sup> formulation focuses on default-mode portfolios. It is an actuarial model that was developed by Credit Suisse Financial

Products. The mathematical formulation is conceived to obtain a fully analytical description of the portfolio loss distribution. No simulations are required. The model uses default intensities  $\lambda = -\ln(1 - \text{PD})$  that are approximately equal for small PD values:  $\lambda \simeq \text{PD}$ . The default intensities are made dependent on sector factors  $S_i$ . The conditional default risk of obligor  $j$  is equal to

$$\text{PD}_{S,j} = \text{PD}_j \left( 1 - \sum_{i=1}^{m_S} w_{ji} \right) + \text{PD}_j \sum_{i=1}^{m_S} \frac{w_{ji} S_i}{\mathbb{E}[S_i]},$$

where  $\text{PD}_j$  denotes the unconditional default risk. The factor weights or loadings  $w_{ji} \in [0, 1]$  denote the importance of the sector  $i$  for the risk evaluation of obligor  $j$ . The remainder

$$w_{j0} = 1 - \sum_{i=1}^{m_S} w_{ji} \in [0, 1]$$

represents the weight of the obligor specific or idiosyncratic risk. The factor loadings introduce the dependence between the defaults. For large values of the sector  $S_i$ , all obligors with high loading  $w_{ji}$  will exhibit higher default risk.

The model formulation is applicable for default mode and assumes a constant LGD. The mathematics of the CreditRisk<sup>+</sup> have been disclosed by the developers. Other developers in industry and academics have made many adaptations and extensions to the approach [223]. A mathematical description is provided in book II. It is available from the technical documentation [121] and the literature [82, 132, 223, 514].

### 5.6.6 Structured product models

The asset pool of structured products is a small portfolio with hundreds to thousands of assets, as depicted in Fig. 1.17. Many models nowadays use Monte Carlo simulation techniques depicted in Fig. 5.8. Some differences with the classical portfolio models are the different time horizon, pre-payment risks and legal risks. The maturity of the structured products is typically larger than the one-year horizon for portfolio models. For some products, like mortgage-backed assets, interest rate and pre-payment risks are also evaluated. For CDOs, correlation and dependence modelling is the key challenge. For ABSs, the granularity aspect is less important and one can use historical loss statistics of the originator. There exists a rich literature on alternatives for Monte Carlo simulation, a.o., [82, 133, 223, 382, 391]. A comparison between CDO models is made in [143].



## 312 Portfolio models for credit risk

A well-known pioneering model for evaluating CDOs is the binomial expansion technique (BET) from Moody's [114]. The portfolio loss distribution of  $N$  assets is approximated by a binomial probability distribution of  $D \leq N$  assets, where  $D$  depends on the concentration and correlation. When reducing  $N$  to  $D$ , an important step is the computation of the diversity score that depends, a.o., on the correlation between the different sectors of the asset pool.

The risk analysis also includes a legal risk analysis and an analysis of the different parties involved in the deal, especially for complex deals with many parties involved.

### 5.7 Basel II portfolio model

The Basel II risk weights (RW) are a function of the issuer and issue risk. The risk weight determines a lower floor on the minimum required capital for credit risk:

$$\text{bank capital} \geq 8\% \sum_i \text{risk weights}_i.$$

The 8% proportionality factor was introduced in the Basel I Capital Accord to have sufficient capital buffers in the banking sector [49, 63]. The 8% can be increased by local regulators. The Basel II risk weight factors are derived from a specific portfolio model developed by the Basel Committee on Banking Supervision. Given that the model and the corresponding formulae are used for capital adequacy supervision, the derivation was developed subject to an important restriction in order to fit supervisory needs.

The model has to be portfolio invariant, i.e. the capital required for any given loan should only depend upon the risk of that loan and should not depend on the portfolio to which the loan is added or belongs. Indeed, for supervisory needs, it is too complex for banks and supervisors to take into account the actual portfolio composition for determining capital for each loan. It has been proven that under certain conditions a one-factor portfolio model is portfolio invariant when the number of loans in the bank goes to infinity [213].

Note that such a formulation does not take into account the diversification of the portfolio, as is done with more sophisticated portfolio models mentioned in section 5.6. The Basel II model therefore assumes that the bank's portfolios are well diversified. The lack of diversification is expected to be taken into account under pillar 2 as explained in the next chapter. The

supervisors may have to take action if this is not sufficiently addressed by the bank.

An introductory note on the Basel II risk weights [57] from the Basel Committee is available from the BIS website ([www.bis.org](http://www.bis.org)).

### 5.7.1 One-factor model

Given that the capital allocated to the loan in the portfolio-invariant model only depends upon the PD, LGD and EAD, the approach is called a ratings based approach (RBA). Generally, only asymptotic risk factor models (ARFM) can be used with a ratings-based approach [213]. Asymptotic risk factor models are derived from general portfolio models with the number of counterparts going to infinity, corresponding to an infinitely granular portfolio. In an infinitely granular portfolio, the idiosyncratic risks associated to each individual exposure cancel out and only the systematic risk affecting many exposures, determines the portfolio distribution and losses. The Basel II formulae are derived from the Vasicek one-factor risk model (eqn 5.22) where the single risk factor is fixed to a confidence level of 99.9%. Assuming a constant LGD and EAD, the value-at-risk of the portfolio is then obtained as

VaR(0.999)

$$= \overline{\text{EAD}} \times \overline{\text{LGD}} \times \Phi_N \left( \sqrt{\frac{1}{1-\varrho}} \Phi_N^{-1}(\text{PD}) + \sqrt{\frac{\varrho}{1-\varrho}} \Phi_N^{-1}(0.999) \right), \quad (5.35)$$

with  $\Phi_N$  and  $\Phi_N^{-1}$  the standard normal and inverse standard normal cumulative distribution function, respectively. The systematic risk factor is put at  $\eta = \Phi_N^{-1}(0.999)$ . The parameter  $\varrho$  measures the correlation between the asset prices of the firms. It measures to what degree the asset values of the obligor depend upon the general state of the economy. The third factor in the function (eqn 5.35) maps the average PD into a 99.9% conservative default rate (DR).

The confidence level is put at 99.9%, which means that a bank is expected to suffer losses that exceed the banks capital on average once in 1000 years, or that about 1 out of 1000 banks is expected to have financial difficulties if no further actions are taken. Although this may seem a high number, it should be noticed that other aspects like diversification, and the loss-absorbing capacity of all the capital, are not fully taken into account. As explained in the next

chapter, the bank’s regulatory capital is composed of different capital types called Tier 1, 2 and 3 capital with different loss-absorbing characteristics.

The LGDs are not stressed in the Basel II formulae [57]. The LGD is not conditional on an economic risk factor or on the systematic risk factor. This means that it is assumed that the real LGD values will be close to the average LGD in periods with a high number of defaults. Recall that some LGD studies report higher losses in downturn periods with high default rates [16, 133, 227, 432]. Therefore, the LGD used in the Basel II risk formulae is required to be a stressed *downturn*  $\overline{\text{LGD}}^*$  [60]. It should be noticed that the Basel Committee on Banking Supervision also considered the use of a mapping function<sup>67</sup> to estimate downturn LGDs that would correspond to an average LGD. Such a function could depend upon many factors like the average LGD, state of the economy, exposure class, industry sector, product type, type and amount of collateral. As LGD scoring and quantification is a relatively new and emerging field, the BCBS determined that the use of a single supervisory LGD mapping function would be inappropriate at this moment. Banks applying the advanced internal-ratings-based approach have to estimate themselves the downturn LGDs that exceed typical business condition LGDs. Supervisors will monitor these developments and will encourage approaches to quantify downturn LGDs [57]. The same rule applies for the exposure at default. For volatile exposures, e.g., revolving credits, one needs to determine a downturn  $\overline{\text{EAD}}^*$ .

The regulatory VaR for a loan is then obtained as

$$\text{VaR} = \overline{\text{EAD}}^* \times \overline{\text{LGD}}^* \times \Phi_N \left( \sqrt{\frac{1}{1-\varrho}} \Phi_N^{-1}(\text{PD}) + \sqrt{\frac{\varrho}{1-\varrho}} \Phi_N^{-1}(0.999) \right), \tag{5.36}$$

which can be split into an expected loss and unexpected loss part:

$$\text{EL} = \overline{\text{EAD}}^* \times \overline{\text{LGD}}^* \times \text{PD} \tag{5.37}$$

$$\begin{aligned} \text{UL} = \text{RC} = & \overline{\text{EAD}}^* \times \overline{\text{LGD}}^* \\ & \times \left( \Phi_N \left( \sqrt{\frac{1}{1-\varrho}} \Phi_N^{-1}(\text{PD}) + \sqrt{\frac{\varrho}{1-\varrho}} \Phi_N^{-1}(0.999) \right) - \text{PD} \right), \end{aligned} \tag{5.38}$$

<sup>67</sup> Note that the US regulators recently proposed to apply a mapping function  $\overline{\text{LGD}}^* = 0.08 + 0.92 \overline{\text{LGD}}$ .

where the unexpected loss is obtained by subtraction of the expected loss (eqn 5.37) from the required VaR (eqn 5.38). Note that since the Madrid compromise of January 2004, the BCBS agreed that bank capital should only cover unexpected loss. The expected loss part is covered by provisions, pricing, etc. [63].

Observe that it has been opted to use the stressed  $LGD^*$  to calculate the expected loss avoiding additional compliance and validation requirements. The VaR consists of the EL and UL, for which the components are illustrated for an LGD of 100% in Fig. 5.13. Observe that the VaR is a convex function of the PD. This means that less capital is required when the discrimination is increased. Consider a portfolio where 50% of the portfolio has a PD of 0.5% and the other 50% has a PD of 1%. For an LGD of 100% and  $\rho = 20\%$ , the

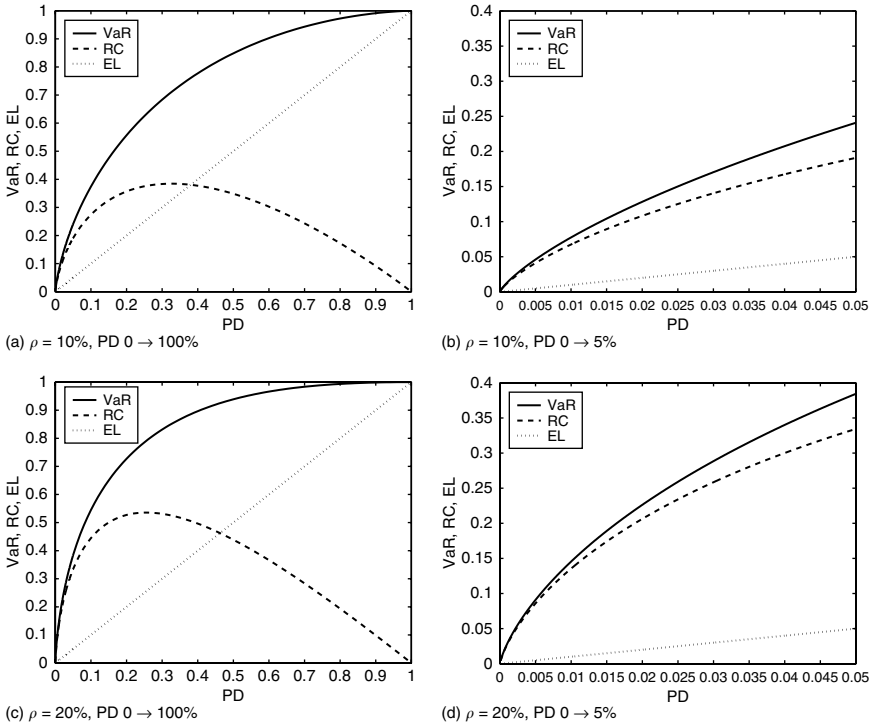

**Fig. 5.13** Value-at-risk (VaR), regulatory capital (RC) and expected loss (EL) as a function of the average PD with full loss ( $LGD = 100\%$ ) for asset correlations of  $\rho = 10\%$  and  $\rho = 20\%$ . The highest amount of regulatory capital is required for PD values ranging from 10% to 20%. The regulatory capital represents the unexpected loss. For low PD values, the UL is the most important component of the VaR. For high PD values, the EL is the most important component.

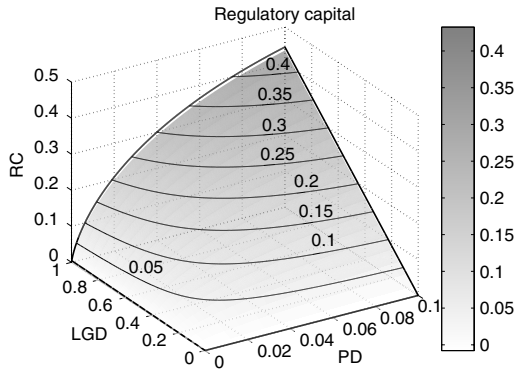

(a) RC:  $\varrho = 20\%$ ,  $M=1$  (3D)

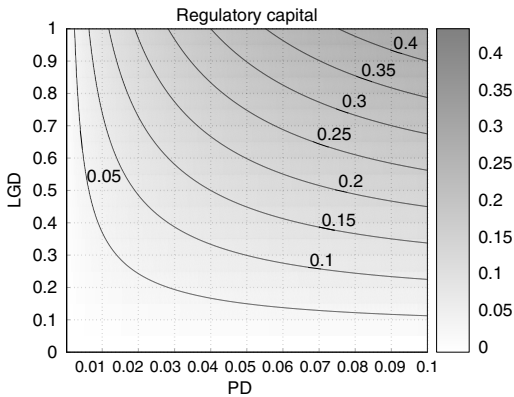

(b) RC:  $\varrho = 20\%$ ,  $M=1$  (contour)

**Fig. 5.14** Regulatory capital as a function of PD and LGD. It is a linear function of the LGD and a convex function of the PD.

VaR is equal to 3.28%. If no distinction was made, the portfolio would have an average PD of 0.75% and VaR of 3.26% per Euro. The impact is most important in zones with a higher curvature, i.e. a low PDs. The risk capital as a function of PD and LGD for  $\varrho = 20\%$  is illustrated in Fig. 5.14.

An exception to these rules are the defaulted loans ( $PD = 1$ ) for which the average LGD is applied and the difference from the stressed  $\overline{LGD}^*$  is used as a capital buffer:

$$EL(\text{default}) = EAD \times LGD \tag{5.39}$$

$$UL(\text{default}) = EAD \times (LGD^* - LGD). \tag{5.40}$$

In the event of default, the EAD is known. The corresponding risk weights<sup>68</sup> (RW) are

$$\begin{aligned}
 RW &= 12.5 \times \overline{\text{LGD}}^* \\
 &\times \left( \Phi_N \left( \sqrt{\frac{1}{1-\rho}} \Phi_N^{-1}(\text{PD}) + \sqrt{\frac{\rho}{1-\rho}} \Phi_N^{-1}(0.999) \right) - \text{PD} \right) \\
 RW(\text{default}) &= 12.5 \times (\overline{\text{LGD}}^* - \overline{\text{LGD}}), \tag{5.41}
 \end{aligned}$$

where the factor 12.5 is introduced to fit the 8% capital adequacy rule, i.e.  $12.5 \times 8\% = 1$ . The above expressions are called risk weight functions that yield the regulatory risk weight based upon internal or supervisory risk components or risk parameters PD,  $\overline{\text{LGD}}^*$ ,  $\overline{\text{LGD}}$ , EAD and  $\rho$ . The impact of the maturity is defined below in eqn 5.46.

### 5.7.2 Asset correlations

The asset correlation  $\rho$  determines the dependency of the borrower’s assets on the state of the economy. The higher the correlation, the higher are the assets of the borrowers jointly dependent on the state of the economy and the more likely are they to jointly default. Generally speaking, the higher the asset correlation  $\rho$ , the fatter are the tails of the loss distribution and the more likely become high unexpected losses. As a result, more capital is required for a portfolio with highly correlated borrowers.

The asset correlation determines the shape of the risk weight formulae and the level of required capital. The asset correlation is asset class dependent: some asset classes (e.g. large firms) are more correlated and dependent on the state of the economy than other asset classes (e.g. revolving retail exposures). For the calibration of the asset correlation for firm, bank and sovereign exposures, the Basel Committee has studied datasets from the G10 supervisors, with the following empirical and financially intuitive findings:

1. The assets correlations tend to decrease with PDs. Intuitively this is explained by the effect that for more risky firms, idiosyncratic risk factors of the borrower become more important (e.g., the commercial success of a new product). High-quality firms are more subject to systemic economic downturns.

<sup>68</sup> Note that an additional scaling factor of 1.06 is proposed in the 2006 Capital Accord to maintain capital levels for banks that use the so-called internal-ratings-based approach.

2. The asset correlations increase with firm size: the larger the firm, the more dependent its performance becomes on the state of the economy.

The calibration of the asset correlation formula resulted in the following formula

$$\varrho = 0.12 \times \frac{1 - \exp(-50PD)}{1 - \exp(-50)} + 0.24 \times \left( 1 - \frac{1 - \exp(-50PD)}{1 - \exp(-50)} \right).$$

The asset correlation varies from 12% for firms with high PD to 24% for firms<sup>69</sup> with low PD. Correlations for firms with a PD between 0% and 100% are obtained via an exponential interpolation. The firm adjustment is obtained via a linear interpolation between 5 and 50 million turnover:

$$\begin{aligned} \varrho = 0.12 \times \frac{1 - \exp(-50PD)}{1 - \exp(-50)} + 0.24 \times \left( 1 - \frac{1 - \exp(-50PD)}{1 - \exp(-50)} \right) \\ - 0.04 \times H_{01}(1 - (S - 5)/45), \end{aligned} \quad (5.42)$$

with  $H_{01}(x) = x$  ( $x \in [0, 1]$ ),  $H_{01}(x) = 1$  ( $x > 1$ ) and  $H_{01}(x) = 0$  ( $x < 0$ ). For counterparts with annual sales of more than 50 million, the adjustment becomes zero. For counterparts with a 5 million turnover or less, the adjustment becomes  $-4\%$  correlation. Between 5 and 50 million turnover, a linear interpolation is applied. The evolution of the asset correlation (eqn 5.42) as a function of the PD is illustrated in Fig 5.15.

For retail counterparts, 3 different types of correlations are applied to different portfolio types: residential mortgages, qualifying revolving retail exposures and other retail exposures:

**Residential mortgages:** the databases typically show a high and constant correlation for defaults, the correlation coefficient is calibrated into

$$\varrho = 0.15. \quad (5.43)$$

**Qualifying revolving retail exposures:** the correlation is low and constant

$$\varrho = 0.04. \quad (5.44)$$

**Other retail exposures:** the correlation ranges from 16% for high PDs to 3% for low PDs. The correlation for other intermediate PDs is obtained

<sup>69</sup> There exists a subclass with a higher correlation ranging from 12% to 30%. This correlation function is applicable for high-volatility commercial real estate, which exhibited highly correlated losses in the past.

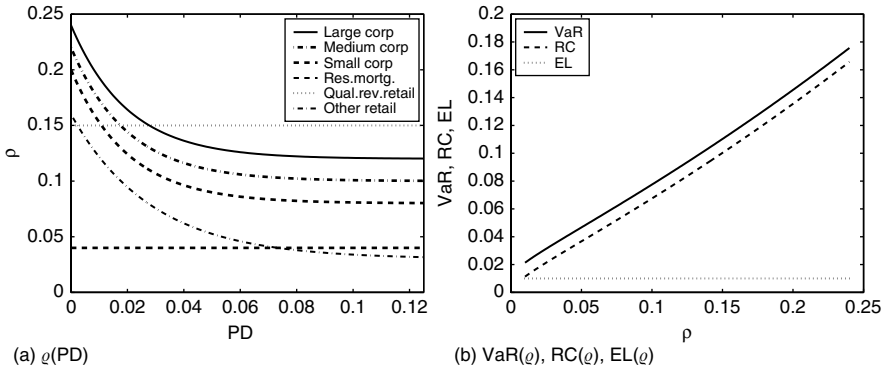

**Fig. 5.15** Regulatory asset correlations (left) for various asset classes (large firms (annual sales  $\geq 50$  million), medium-size firms (annual sales = 27.5 million), small firms (annual sales  $\leq 5$  million), residential mortgages, qualifying revolving retail exposures and other retail exposures). The impact of the asset correlation on the VaR, RC and EL from eqns 5.36, 5.37 and 5.38 is illustrated in the left pane for a PD equal to 1% and LGD equal to 100%.

by an exponentially weighted interpolation

$$\varrho = 0.03 \times \frac{1 - \exp(-35PD)}{1 - \exp(-35)} + 0.16 \times \left( 1 - \frac{1 - \exp(-35PD)}{1 - \exp(-35)} \right). \tag{5.45}$$

The  $k$ -factor for the exponentially weighted interpolation is equal to 35, the correlations (eqn 5.45) decrease slower with increasing PDs than for firms (eqn 5.42) as is illustrated in Fig 5.15.

Observe that for these counterparts, the asset correlation from the Merton framework cannot be measured. Indeed, individuals are not stock-listed and the value of personal assets (possessions, income, job, education, skills) cannot be easily assessed. Therefore, it is important to know that the formulae for the asset correlation are reverse engineered from historical loss data from G10 supervisory databases and economic capital figures from large internationally active banks.

### 5.7.3 Maturity adjustment

Intuitive and empirical evidence shows that long-term credits are more risky than short-term credits. Indeed, on a longer time period, the risk of a rating downgrade is higher than a rating upgrade. Therefore, the capital requirement should increase with maturity.



The Basel Committee on Banking Supervision has developed a mark-to-market credit risk model to capture the effect of potential downgrades and the corresponding loss of market value for long-term loans. The time structure of PDs reflecting migration probabilities has been derived from market data. This time structure describes the likelihood and magnitude of PD changes allowing the maturity adjustment that results from up- and downgrades to be derived.

The resulting value-at-risk from the mark-to-market credit risk model was compared with VaR the Basel II ASRF model. For easy implementation, a maturity adjustment factor is included on top of the ASRF model. Setting the reference maturity to 2.5 years, the model allows the relative values of the 1–5 year VaRs compared to the 2.5-year VaR for different PDs to be attained. These relative values have been smoothed with a statistical regression<sup>70</sup> model:

$$M_{\text{adj}} = \frac{1 + (M - 2.5)b(\text{PD})}{(1 - 1.5 \times b(\text{PD}))} \quad (5.46)$$

with  $b(\text{PD}) = (0.11852 - 0.05478 \ln(\text{PD}))^2$ . The maturity adjustment transforms the hold-to-maturity formula (eqn 5.38) to a mark-to-market generic portfolio formula for longer maturities. The correction is calibrated such that the adjustment for  $M = 1$  corresponds to no adjustment. The adjustments increase linearly with the maturity  $M$ , the slope of the adjustment decreases with increasing PD. The maturity adjustment is illustrated in Fig. 5.16. It illustrates clearly the high importance for good-rated counterparts.

Note that the maturity adjustment is applicable for sovereigns, banks and firms, but not for retail. The resulting risk weight for sovereigns, banks and firms is obtained by adjusting eqn 5.41 with eqn 5.46:

$$\begin{aligned} \text{RW} &= 12.5 \times \overline{\text{LGD}}^* \quad (5.47) \\ &\times \left( \Phi_N \left( \sqrt{\frac{1}{1-\varrho}} \Phi_N^{-1}(\text{PD}) + \sqrt{\frac{\varrho}{1-\varrho}} \Phi_N^{-1}(0.999) \right) - \text{PD} \right) \\ &\times \frac{1 + (M - 2.5)b(\text{PD})}{(1 - 1.5 \times b(\text{PD}))}. \end{aligned}$$

For defaulted exposures, the maturity adjustment is not applicable. Banks that apply the foundation internal-ratings-based approach apply standard

<sup>70</sup> Statistical regression models are discussed in book II.

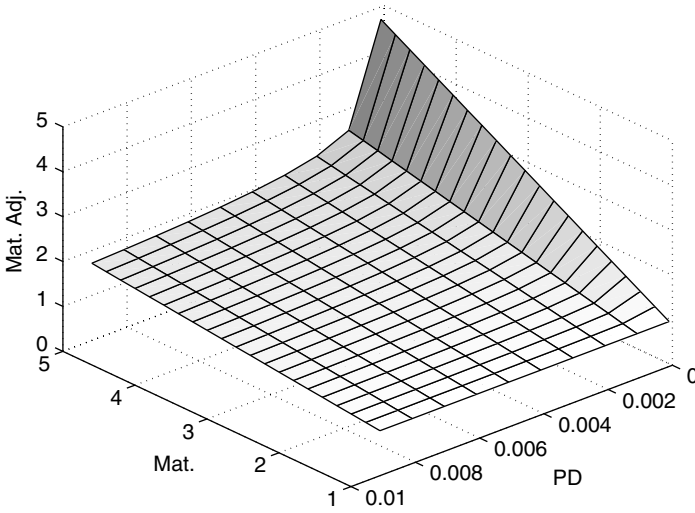

**Fig. 5.16** Maturity adjustment as a function of the PD and maturity  $M$ . The maturity adjustment is limited between 1 and 5 years. The highest sensitivity is observed for low PD values. Those ratings are most sensitive to a downgrade.

maturity estimates, which are mostly equal to 2.5 years. In the foundation internal-ratings-based approach, the maturity is estimated by the banks. The maximum maturity adjustment is equal to 5 years.

#### 5.7.4 Double default framework

Credit risk mitigants, like credit guarantees and credit default swaps, allow reduction of the risk on a credit exposure. In the case of a guarantee, the bank makes a loan to an obligor and obtains protection against default from the guarantee, as depicted in Fig. 5.17. Often, the obligor pays the (financial) guarantor directly a fee for the credit enhancement, which is an integral part of the loan negotiation with the bank. In the case of a credit default swap, the bank purchases the protection independently from the obligor. In exchange for the fee, the guarantor accepts to pay principal and/or interest losses in case of default of the obligor. In both cases, the bank suffers a loss only in the case of a double default of both the obligor and guarantor.

In the banking industry, there is a strong belief that a guaranteed loan bears much lower risk than the non-guaranteed loan. However, regulators point out that there exists a limited number of guarantors that are subject to

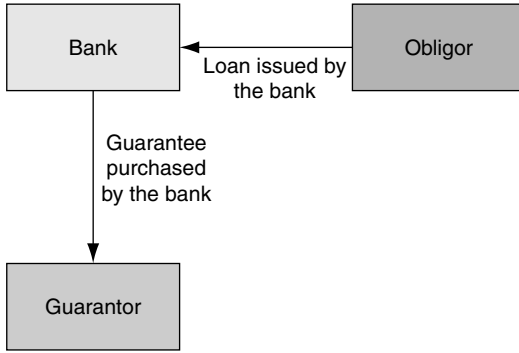

**Fig. 5.17** Credit guarantee arrangement: the bank obtains protection against the default risk on the issued loan from the guarantor. The bank suffers a loss in the case of a double default of both the obligor and guarantor.

systematic risk. In the case of a severe crisis, the joint default probability of both obligor and guarantor becomes much higher than under normal market conditions. In addition, there are many questions on the maturity of the credit derivative market. Do such products effectively offer protection in the case of a severe crisis?

The initial proposition for guaranteed loans was to apply a substitution of the PD and/or LGD in the risk weight calculations. The risk weight of the protected loan is the lowest of the risk weight of the obligor and the risk weight of the guarantor. Because of market reactions, a specific risk weight formula has been proposed for guaranteed loans. It is obtained by introducing an additional factor in eqn 5.25:

$$r_o = \sqrt{\varrho_o} \eta + \sqrt{1 - \varrho_o} (\sqrt{\psi} \xi + \sqrt{1 - \psi} \varepsilon_o),$$

$$r_g = \sqrt{\varrho_g} \eta + \sqrt{1 - \varrho_g} (\sqrt{\psi} \xi + \sqrt{1 - \psi} \varepsilon_g),$$

where the subscripts o and g denote the obligor and guarantor parameters, respectively. The additional correlation between obligor and guarantor is obtained from the additional (standard normal distributed) factor  $\xi$  and the correlation parameter  $\psi$ . In the case of  $\psi = 0$ , the only correlation between obligor and guarantor is obtained from the systematic factor  $\eta$ . In the case of  $\psi > 0$ , the asset correlation between obligor and guarantor equals

$$\rho(r_o, r_g) = \sqrt{\varrho_o \varrho_g} + \psi \sqrt{1 - \varrho_o} \sqrt{1 - \varrho_g}.$$

The higher the correlation  $\psi$ , the higher is the asset correlation between obligor and guarantor returns. The resulting VaR is equal to

$$\begin{aligned} \text{VaR}(0.999) = & \overline{\text{EAD}}^* \times \overline{\text{LGD}}_o^* \times \overline{\text{LGD}}_g^* \\ & \times \Phi_{N^2} \left( \frac{\Phi_N^{-1}(\text{PD}_o) + \sqrt{\varrho_o} \Phi_N^{-1}(0.999)}{1 - \varrho_o}; \right. \\ & \left. \frac{\Phi_N^{-1}(\text{PD}_g) + \sqrt{\varrho_g} \Phi_N^{-1}(0.999)}{1 - \varrho_g}; \psi \right), \end{aligned} \quad (5.48)$$

where  $\Phi_{N^2}$  denotes the cumulative bivariate normal distribution with correlation  $\psi$ . The two limiting cases are

1. If  $\psi$  is zero, the bivariate normal becomes the product of the two normal distributions and the VaR is the product of the obligor and guarantor VaR:  $\text{VaR}_{\text{DD}}(0.999) = \text{VaR}_o(0.999) \cdot \text{VaR}_g(0.999)$ .
2. In the case of full correlation ( $\psi = 1$ ), the VaR is the lowest of the obligor and guarantor VaR:  $\text{VaR}_{\text{DD}}(0.999) = \min(\text{VaR}_o(0.999), \text{VaR}_g(0.999))$ .

A common assumption has been to make the guarantors highly correlated on the systemic risk  $\varrho_g = 0.7$  and to calibrate the correlation between obligor and guarantor as  $\rho(r_o, r_g) = 0.5$ , from which  $\psi$  follows [62, 247].

Note also that the VaR depends on both the LGD of the guarantor and the obligor, assuming that the bank first tries to get its money back from the obligor and the remaining part from the guarantor or vice versa. Note that there exist different legal schemes that specify the recovery process. In some credit derivatives, the guarantor payment is full and does not depend on the bank recovery on the obligor: a double recovery is possible. In classical guarantee schemes, the guarantor pays the bank in return for the rights on the defaulted facility: double recovery is less likely.

The VaR formula (eqn 5.48) is simplified by the regulators into the following risk capital (RC) formula

$$\begin{aligned} \text{RC}_{\text{DD}} = & \overline{\text{EAD}}_g^* \text{RC}_D(0.15 + 160\text{PD}_g) \\ \text{RC}_D = & \overline{\text{LGD}}_g^* \times \left( \Phi_N \left( \sqrt{\frac{1}{1 - \varrho_o}} \Phi_N^{-1}(\text{PD}_o) + \sqrt{\frac{\varrho_o}{1 - \varrho_o}} \Phi_N^{-1}(0.999) \right) - \text{PD}_o \right) \\ & \times \frac{1 + (M - 2.5)b(\text{PD})}{(1 - 1.5 \times b(\text{PD}))}, \end{aligned} \quad (5.49)$$

**Table 5.3** Risk weights for an unhedged firm exposure and a hedged exposure calculated with the substitution approach and the double-default risk weight formula. The firm PD rating varies from AAA to CCC (Table 3.2), while the guarantor rating ranges from AAA–AA to BB, though the latter are not recognized as eligible. Due to a PD floor of 0.03%, there is no difference between AAA and AA. The LGDs values are 30% and 45%. The double default formula reflects the lower risk for good-rated guarantors.

		LGD <sub>o</sub> = 30%, LGD <sub>g</sub> = 30%						
RW Method	PD <sub>g</sub> \PD <sub>o</sub>	AAA	AA	A	BBB	BB	B	CCC
Unhedged		9.8%	9.8%	11.7%	30.4%	69.5%	134.9%	238.5%
Substitution	<b>AA</b>	9.8%	9.8%	9.8%	9.8%	9.8%	9.8%	9.8%
Substitution	<b>A</b>	9.8%	9.8%	11.7%	11.7%	11.7%	11.7%	11.7%
Substitution	<b>BBB</b>	9.8%	9.8%	11.7%	30.4%	30.4%	30.4%	30.4%
Substitution	<b>BB</b>	9.8%	9.8%	11.7%	30.4%	69.5%	69.5%	69.5%
Double default	<b>AA</b>	1.9%	1.9%	2.3%	6.0%	13.8%	26.7%	47.2%
Double default	<b>A</b>	2.1%	2.1%	2.5%	6.5%	14.9%	28.9%	51.0%
Double default	<b>BBB</b>	4.6%	4.6%	5.5%	14.3%	32.7%	63.4%	112.1%
Double default	<b>BB</b>	19.3%	19.3%	23.0%	59.4%	136.1%	264.2%	467.0%
		LGD <sub>o</sub> = 45%, LGD <sub>g</sub> = 30%						
RW Method	PD <sub>g</sub> \PD <sub>o</sub>	AAA	AA	A	BBB	BB	B	CCC
Unhedged		14.8%	14.8%	17.6%	45.5%	104.3%	202.4%	357.8%
Substitution	<b>AA</b>	9.8%	9.8%	9.8%	9.8%	9.8%	9.8%	9.8%
Substitution	<b>A</b>	11.7%	11.7%	11.7%	11.7%	11.7%	11.7%	11.7%
Substitution	<b>BBB</b>	14.8%	14.8%	17.6%	30.4%	30.4%	30.4%	30.4%
Substitution	<b>BB</b>	14.8%	14.8%	17.6%	45.5%	69.5%	69.5%	69.5%
Double default	<b>AA</b>	1.9%	1.9%	2.3%	6.0%	13.8%	26.7%	47.2%
Double default	<b>A</b>	2.1%	2.1%	2.5%	6.5%	14.9%	28.9%	51.0%
Double default	<b>BBB</b>	4.6%	4.6%	5.5%	14.3%	32.7%	63.4%	112.1%
Double default	<b>BB</b>	19.3%	19.3%	23.0%	59.4%	136.1%	264.2%	467.0%
		LGD <sub>o</sub> = 30%, LGD <sub>g</sub> = 45%						
RW Method	PD <sub>g</sub> \PD <sub>o</sub>	AAA	AA	A	BBB	BB	B	CCC
Unhedged		9.8%	9.8%	11.7%	30.4%	69.5%	134.9%	238.5%
Substitution	<b>AA</b>	9.8%	9.8%	11.7%	14.8%	14.8%	14.8%	14.8%
Substitution	<b>A</b>	9.8%	9.8%	11.7%	17.6%	17.6%	17.6%	17.6%
Substitution	<b>BBB</b>	9.8%	9.8%	11.7%	30.4%	45.5%	45.5%	45.5%
Substitution	<b>BB</b>	9.8%	9.8%	11.7%	30.4%	69.5%	104.3%	104.3%
Double default	<b>AA</b>	2.9%	2.9%	3.5%	9.0%	20.6%	40.1%	70.8%
Double default	<b>A</b>	3.2%	3.2%	3.8%	9.7%	22.3%	43.3%	76.6%
Double default	<b>BBB</b>	6.9%	6.9%	8.3%	21.4%	49%	95.1%	168.2%
Double default	<b>BB</b>	28.9%	28.9%	34.4%	89.2%	204.2%	396.3%	700.5%
		LGD <sub>o</sub> = 45%, LGD <sub>g</sub> = 45%						
RW Method	PD <sub>g</sub> \PD <sub>o</sub>	AAA	AA	A	BBB	BB	B	CCC
Unhedged		14.8%	14.8%	17.6%	45.5%	104.3%	202.4%	357.8%
Substitution	<b>AA</b>	14.8%	14.8%	14.8%	14.8%	14.8%	14.8%	14.8%
Substitution	<b>A</b>	14.8%	14.8%	17.6%	17.6%	17.6%	17.6%	17.6%
Substitution	<b>BBB</b>	14.8%	14.8%	17.6%	45.5%	45.5%	45.5%	45.5%
Substitution	<b>BB</b>	14.8%	14.8%	17.6%	45.5%	104.3%	104.3%	104.3%
Double default	<b>AA</b>	2.9%	2.9%	3.5%	9.0%	20.6%	40.1%	70.8%
Double default	<b>A</b>	3.2%	3.2%	3.8%	9.7%	22.3%	43.3%	76.6%
Double default	<b>BBB</b>	6.9%	6.9%	8.3%	21.4%	49.0%	95.1%	168.2%
Double default	<b>BB</b>	28.9%	28.9%	34.4%	89.2%	204.2%	396.3%	700.5%

where the maturity adjustment is calculated on the counterparty with the lowest default probability ( $PD = \min(PD_o, PD_g)$ ). The maturity  $M$  is the effective maturity of the credit protection. The resulting capital requirement consists for an important part of the capital requirement of a non-guaranteed exposure  $K_D$  with some changes in the LGD and the maturity. The correction term depends on the PD of the guarantor and reduces the risk weight, especially for well-rated guarantors. The expected loss is zero. The risk weight is obtained by multiplying the risk capital with the factor 12.5.

The risk weights are illustrated in Table 5.3 using the substitution approach and the double default formula (eqn 5.49) for a maturity of 2.5 years. Compared to the unhedged exposure, the substitution risk weight is not much lower, especially not when the risk of the firm is comparable to that of the guarantor. The double default clearly indicates a benefit, especially for good-quality guarantors. For lower-rated guarantors, the benefit reduces. Below investment grade, the benefit is very limited. Note that the formula is only valid for investment-grade guarantors, as guarantees with ratings below BBB– are not recognized.

## 5.8 Implementation and application

The implementation of a credit portfolio model is a complex task. The function of portfolio modelling itself is typically allocated to a dedicated team that calibrates the model and sets up the IT framework. The results of the credit portfolio model are used in the economic capital calculations of the financial institution. Some key elements for a successful implementation are:

**Scope:** The portfolio risk is calculated on the credit portfolio of the bank and/or relevant subportfolios of the business lines or major entities. All relevant data needs to be collected to assess the risk of the bank. The risks that the portfolio model needs to assess and measure are clearly articulated. An important choice is the issue of using economic or accountancy data. Stated otherwise, one needs to choose between default-mode and mark-to-market approaches.

**Data collection:** Consistent criteria need to be defined to uniformize the meaning of exposure and data in the bank. When several data sources exist, a coherent mapping to a uniform framework is applied. Exposures need to be aggregated on a single counterparty by means of a unique ID. Data quality, consistency and integrity need to be ensured. Positions are stored sufficiently frequently to track portfolio evolutions. Losses are also stored

to allow for a historical evaluation of the model and its parameters. Results are benchmarked with other internal data sources, e.g., from financial reporting. Where possible, accountancy information reported is put in line with portfolio measures.

**Risk measures and parameters:** Uniform risk measures are needed to aggregate portfolios of different business lines. The classical single-name risk measures like PD, LGD and EAD need to be defined consistently. Comparisons across portfolios with different risk measures are difficult and complex corrections are necessary. Dependence across loss events and risk measures and the data to compute such dependencies, are measured and implemented uniformly. Ideally, the applied parameters, valuation models and portfolio modelling methodology are validated by an independent internal (or external) review before the results are actually used within the organization.

**Methodology choices:** The methodology and parameter choices need to be coherent with the identified scope. One needs to choose the risk types that will be addressed, the dependencies and their parameterizations. The implementation will also impact the IT implementation and computational requirements.

**Reporting:** The portfolio risk is communicated consistently in a simple and understandable way to senior management, e.g., expected loss, earnings at risk, VaR, expected shortfall, sensitivity measures. The reporting tools allow measurement of the performances and risk positions of the different subportfolios.

A list of sound practices has been disclosed in [222]. The portfolio model results can be used for risk management purposes:

**Limit systems:** The techniques mentioned in section 1.6 are applied. Limits are defined to avoid high correlation and concentration risk. These limits no longer depend on classical maximum exposure or maximum expected loss, but also on portfolio risk-based measures like VaR, expected shortfall and marginal contributions.

**Stress testing:** Portfolio models can be applied for stress testing the portfolio. Stress tests can be sensitivity- and scenario-based analyses. Sensitivity measures report the increase of portfolio risk parameters as a function of increasing PD, LGD, CCF, correlation or other explanatory factors. Scenario stress tests apply plausible, but likely scenarios such as an economic crisis in a key sector, or the default of important concentrations. Stress testing is explained in book III.

**Portfolio balancing:** Mark-to-market or mark-to-model approaches for trading book<sup>71</sup> portfolios allow close monitoring of the risk position and active rebalancing of the portfolio by selling or buying assets or protection. Buy, sell and hedge decisions are made to make the portfolio efficient (see section 5.9.3.2 for the definition of an efficient portfolio). The active management allows the portfolio to be kept in line with the bank's strategy.

**Basel II:** The Basel II portfolio model is a simplified version to determine a regulatory capital floor. Not all risks, e.g., concentration effects are included in a generic portfolio model. The Basel II pillar II asks banks to address the impact of such effects and to explain differences of internal portfolio results with the Basel II results. The internal portfolio models are used for capital adequacy testing.

**Economic capital:** Credit portfolio capital requirements are part of the global capital requirements for the bank. The portfolio results are used to determine capital requirements and to allocate it to the different entities and/or business lines. With economic capital, portfolio models also serve as an input for risk-adjusted pricing models.

The increased liquidity of credit markets and credit derivative products reduce the differences between market risk and credit risk management practices.

## 5.9 Economic capital and capital allocation

Regulatory capital is the amount of capital the financial institution needs to have to provide protection against statutory insolvency. It is based upon general rules defined by supervisory bodies that need to be applicable on a wide range of financial markets and legal systems. A financial institution needs to operate above its minimum regulatory capital requirement, if not, regulators may intervene. Rating agencies balance the capital amount against the risk position, but their formulas are not disclosed. The higher the capital for the same amount of risk and the same risk management, the better the rating.

Economic capital defines the capital that is needed to protect the group against economic solvency. It is the amount of capital, calculated by the bank and at the confidence level chosen by the management, that is necessary to absorb unexpected movements in assets and liabilities.

<sup>71</sup> The trading book definition is provided in section 6.3.2.



While regulatory capital is obtained by general rules, economic capital is often defined by the institution's risk management and is specific for the institution. Regulatory capital is often defined for a specific activity (banking, insurance, securities). Economic capital is defined at the group level of a financial conglomerate with various activities.

### **5.9.1 Risk types in financial conglomerates**

Recent history witnessed the growth of large financial conglomerates: groups of companies under common control and ownership structure with dominant activities in at least two different financial sectors (banking, securities, finance) [471]. The emergence of such groups resulted from deregulation, globalization, one-stop shopping demands and diversification benefits.

One reason for the existence of large financial groups are economies of scale, although cost efficiency has been proven in some cases to be difficult [74, 72, 267, 393]. Scale economies on the risk management are achieved in an integrated risk management [190]. Economies of scope emerge like lower production costs, consumer demand for one-stop shopping, cross-selling and internal market efficiencies [73, 76, 206, 254]. Risk mitigation and diversification effects are other reasons for mergers and acquisitions [168, 317, 329, 339, 427]. Risk benefits are expected mostly across different sectors and regions, e.g., banks merging with insurance companies or with a bank in another economy or continent.

Banking activities are subject to credit, market and operational risk. Credit and market risk are asset risks: the risk of losing money on the invested assets. Interest rate risk and asset liability management (ALM) are often managed together with market risk. An overview of bank risk types has been provided in section 1.5.

Insurance companies have different risks. Non-life insurance companies sell protection for property and casualty (P&C) risk (e.g., car insurance). Their loss depends on the number of claims and the severity per accident. Both are sources of uncertainty and risk. The loss distribution is empirically well known. The premiums paid by the investors compensate the losses of the claims. Catastrophe risk is the risk of large events (e.g., flooding, tornado or terrorist attack). The low probability events go together with large losses that represent a concentration risk. Reinsurance companies provide P&C insurers against such events. They reduce the concentration by a worldwide scope.

**Table 5.4** Risk types for different financial services. The higher the risk, the more the circle is filled black.

Type	Credit	Market	ALM	Insurance	Operating
Universal bank	●	◐	◑	○	◑
Life insurance	◐	●	◑	◐	◑
P&C insurance	◐	◑	◐	●	◐

Life insurance companies invest the premiums on a longer term in equities and bonds. Because, in most contracts a fixed interest rate is promised, life insurers are subject to market risk on top of the risk of the insurer (e.g., time and amount of cash flow in the (non-)incidence of death). They provide financial protection for the dependents of the insured person and serve as a financial intermediary for long-term savings. Insurance risk consists of the 3 types of risk: P&C risk, catastrophe risk and life risk. Life insurers are highly subject to market risks. Non-bank security firms, e.g., stock brokers or dealers, are subject to operation risk, and liquidity risk as well as to market and credit risk.

Other risk types include business risk and reputation risk. Business risk is sometimes merged with operational risk into operating risk. It concerns changes in volumes, margins and costs. Reputation risk becomes more important for large groups, where spill-over effects from one activity (e.g., a securities firm) to another can impact the whole organization. Table 5.4 indicates the importance of the different risk types for banks and insurance companies [317]. Different financial services have different risk types, that are likely not to be very correlated. The risk that a major credit risk crisis occurs is not dependent on the risk of an important natural disaster. A financial conglomerate can diversify its risk when it is composed of different business lines with lowly correlated risk types. An additional diversification is obtained by a worldwide strategy: it is less likely that major financial crises and natural disasters occur simultaneously in different continents. Figure 5.18 represents different loss distributions.

## 5.9.2 Firm-wide economic capital (EC)

The different risk types are modelled, measured and reported on a different basis. The risk distributions are different, as illustrated in Fig. 5.18.

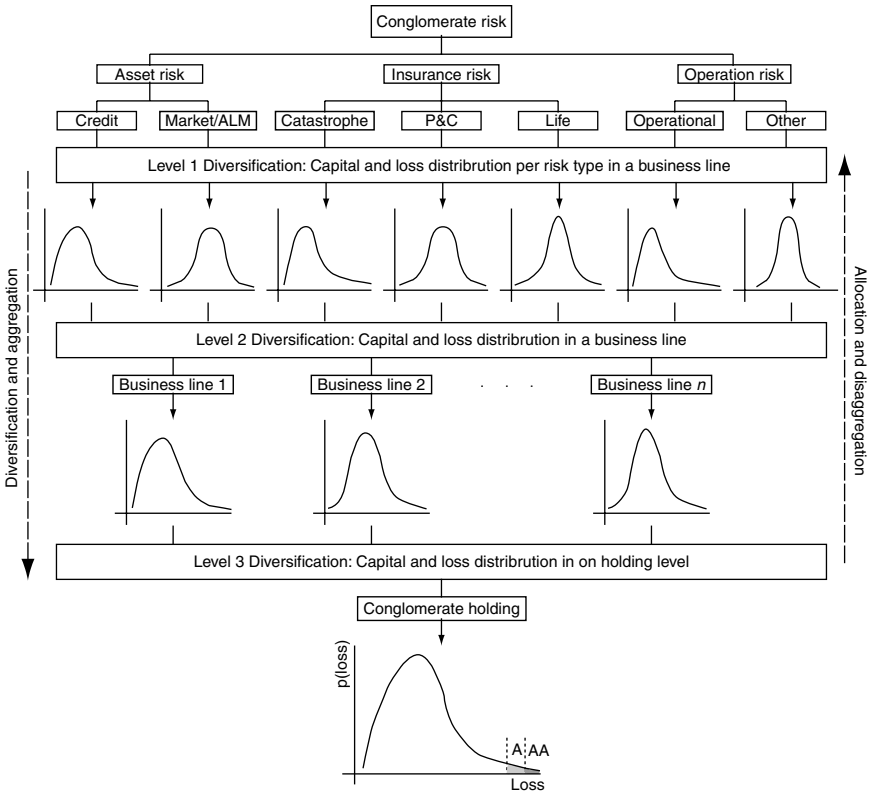

**Fig. 5.18** Risk-type contributions in a financial conglomerate. Banking risk consists typically of credit, market and operational risk. Insurers bear P&C, catastrophe risk or life insurance risk combined with asset and operation risk. Operation risk combines operational risk and other risk types like business risk. The resulting loss distribution of the conglomerate is obtained via different aggregation levels. The capital of the firm with respect to the VaR of the global loss distribution determines the rating [251, 317].

**5.9.2.1 Harmonized risk measurement framework**

A key element to calculate firm-wide EC is the existence of a coherent risk definition and measurement. The different nature of the businesses explains the different approaches for risk measurement, modelling and reporting. A harmonized framework is necessary to compare risks across different entities. Such harmonization involves the measurement and reporting language, the time horizon and the confidence level [472]. A common horizon is the 1-year horizon.

Credit and operational risk are reported typically on an annual basis. Such events have rather low frequency (but high severity) and their reporting, apart

from regulation, is on an annual basis, simultaneously with the reporting of the annual results and the budgeting cycle. The reference holding period<sup>72</sup> for market risk is 10 business days. Market losses occur more frequently, but are less severe than credit losses.

Insurance companies have a different risk management culture. The typical time horizon is several years. The loss distribution results from the frequency and the severity of claims. Life insurance companies think in terms of claims volatility and mortality tables rather than ratings.

All different risk types have different shapes of the loss distribution reported in different units and time horizons. For example, the market risk distribution is proportional to  $\sqrt{252}/\sqrt{10}$  because the volatility in a Brownian motion increases with the square root of the holding period. Essentially, all these risk measures are loss probabilities that are combined in the aggregated loss function of the financial conglomerate. The combined loss probabilities express harmonized risk measures across the bank, insurance and security houses defined in policies and guidelines.

### 5.9.2.2 Goals and use

The economic capital acts as a unique and central currency for risk management. To each business line and product, a part of the economic capital is allocated. The unique currency allows measurement of profitability across different sectors. Supervisors define minimal capital requirements to protect depositors. Economic capital is the bank's internal risk measure, but also has the following additional goals:

**Performance measurement:** This allows computation of the return on economic capital of different business lines and serves as a performance measure. In order to make a fair analysis, a coherent and consistent methodology needs to be agreed upon in the organization.

**Risk-adjusted performance measures:** EC and risk-adjusted performance measures are tools for investment decisions to optimize value creation for investment decisions.

**Diversification management:** This also serves to diversify risk across different business lines by finding an optimal balance between risk and return.

**Strategic planning:** This is a tool to develop the business to diversify better the risk and/or to allocate more capital to the most profitable business

<sup>72</sup> The regulatory market risk requirement charges capital for a 10-day period.

lines. The business plan of the financial conglomerate is aligned with the optimal return/risk ratio to optimize future profitability.

Risk-adjusted performance measures are discussed in paragraph 5.9.5. In the next paragraphs, capital aggregation and allocation are discussed.

The development of an effective EC framework is part of the evolution where the risk management function is concentrated at the firm center. Such evolutions also allow realisation of economies of scale [190]. Rating agencies and regulators recognize the increasing complexity of risk management and are demanding parties for group-wide risk measurement at holding levels.

Opposite pressures influence the amount of regulatory capital (Fig. 5.19). Regulators, bondholders, depositors and policyholders seek confidence and protection against stress scenarios by a sufficient capital buffer. Increased solvency is obtained by more capital [75]. Shareholders, policyholders, and analysts are mainly interested in the profitability. With less capital, a higher return on equity is achieved. Obligors are partially involved: lower

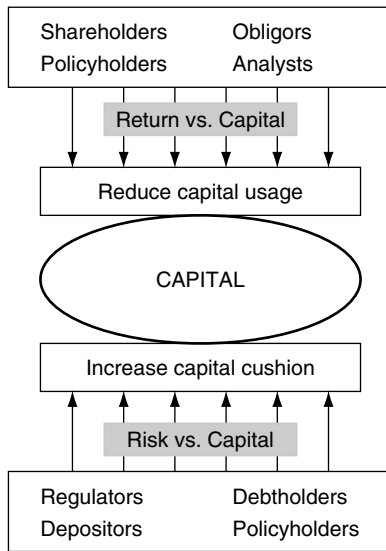

**Fig. 5.19** Opposite pressures on capital use and management. Shareholders search for profitability and develop pressure for an increased return of capital. This can be achieved by reducing capital requirements for the same investment. Regulators seek a better protection of savings and deposit holders. They put pressure for increasing the capital buffer and require higher capital for the same investment. Bondholders will require a lower interest rate for safer banks. Customers and policyholders are interested in a good balance between risk and return.

capital costs allow lower margins. Increased profitability is obtained by lower capital. The capital management balances between both pressures. EC provides a coherent framework for capital management.

### 5.9.3 Aggregation and differentiation

#### 5.9.3.1 Silo Aggregation

Each of the business lines or portfolios in a conglomerate represents a certain amount of risk. The EC of each portfolio is determined by its loss distribution or by a regulatory mapping formula derived from a generic portfolio loss distribution. Typically a VaR measure is used. The EC of the whole conglomerate with portfolios  $P_1, P_2, \dots, P_n$  is calculated in the silo approach as:

$$EC(P_1 + P_2 + \dots + P_n) = EC(P_1) + EC(P_2) + \dots + EC(P_n). \quad (5.50)$$

The amount of capital in the whole organization is obtained by summing up the capital amounts in the individual portfolios or silos. Each business line or portfolio is considered as a stand-alone silo in which the capital to support the activity is calculated independent of the other portfolios. The total capital needed is the sum of the capitals of the individual silos. It is a simple approach that assumes a worst-case scenario in which extreme losses are observed simultaneously, although it is known that correlations increase during stress scenarios [19, 108, 148, 164, 290]. The regulatory approach still uses the silo formula (eqn 5.50) to determine capital adequacy.

The silo approach has different weaknesses [317]:

**Inconsistencies:** The different regulations require different amounts of capital to be set aside. When the bank or insurance silo invests in the same loan or bond, a different amount of capital is required. It is possible to book investments in the silo with the least demanding regulatory regime. Such differences will increase the demand for regulatory arbitrage and product innovation. An overview of regulations is available in [470].

**Aggregation:** The silo formula assumes full dependency across the silos in their entity. Concentration risks are not aggregated. A large concentration in one silo is not known by the other silos. There is no incentive for risk diversification.

**Incompleteness:** Regulation is applicable for licensed companies. Non-licensed subsidiaries (e.g., operating subsidiaries) are not subject to capital requirements, although they represent risk (e.g., operational risk).

A similar argument is valid for holding companies, where one needs to avoid the double-leverage effect. The treatment of strategic investments in non-financial companies is vague, although the Basel II guidelines are a next step.

In addition, there is the technical concern that VaR-based risk measures are not subadditive (see section 5.3). The incompleteness of regulation will hamper efficient enterprise-wide risk management and economic capital calculation, and it will stimulate financial innovation with the development of new financial products for financial arbitrage. The difference between financial products will continue to blur, which expresses the need for a coherent EC approach.

### 5.9.3.2 Risk-level aggregation

The primary task in EC measurement is the aggregation of the different risks in the conglomerate. In each step of risk aggregation, a diversification benefit (eqn 5.11) can be realized. In [317] the risk aggregation is considered on 3 levels:

**Level 1:** The risk is aggregated across a single risk factor (credit risk, market risk, . . .) of Fig. 5.18 on a portfolio level or business line.

**Level 2:** Different risks in a single portfolio are combined and aggregated. In a bank, credit, market, ALM and operating risks are combined.

**Level 3:** The risk is aggregated across different business lines and portfolios. In a bank assurance group, one joins the loss distributions of the banks and insurance groups.

The aggregation of the 3 levels yields the aggregated loss distribution of Fig. 5.18. The diversification also includes netting of positions. For example, when some portfolios are sensitive to an exchange rate increase and others are sensitive to a decrease; these effects compensate in the global portfolio and the net exposure to an exchange rate change is reduced.

Note that different approaches exist to define levels on which risk is aggregated. In a perfect methodological setup, the ways in which risk levels are aggregated, do not change the resulting distribution.

#### Level 1

On the first level, diversification benefits are important, as illustrated in Figs. 5.3–5.6. Most diversification benefits are realized at this level. The diversification benefit is limited by high concentrations indicated by the Herfindahl–Hirschman index and by systematic correlation effects. For

financial markets, correlations with major stock indices exist and limit diversification.

Apart from diversifying across multiple issuers, an additional way to diversify the portfolio is to invest in different geographic regions or economic zones and different asset classes and sectors. It is less likely that a stock market crash and a severe credit crisis occur simultaneously in all zones and asset classes. This is intrarisk diversification and can amount to 55% of capital reduction [317]. When choosing new target regions or sectors, the diversification benefit is the highest when selecting target customer groups that are not correlated with the main customers in the portfolio.

According to the benchmark studies of Oliver, Wyman & Company and the Capital Market Risk Advisors [106, 316] on the capital allocation, credit risk counts for about 50% of the capital, market risk for about 20% and operation and other risks for about 30%. For a life insurer, credit risk counts for 10%, market/ALM for 55%, operating for 30% and life for 5% of the capital. For a P&C insurance company, credit risk is only 2%, market/ALM 37%, operating 10% and P&C risk 51%. For a diversified, composite insurer, the credit risk counts for about 19%, market/ALM for 44%, operating for 5%, P&C for 28% and life risk for 4% [371, 457, 507].

## Level 2

The level 2 diversification occurs on fewer risk factors. The number of different risk types is lower, as seen on Fig. 5.18. The correlation between the main risk types for banks and insurance companies is reported in [317].

The diversification effect across multiple business lines is reported in Fig. 5.20. Depending on the choice of the correlation matrix<sup>73</sup> and the economic capital in Table 5.5a, the level 2 capital is equal to 72% (DA), 77% (WL) and 84% (KSW). The approaches are labelled by the names of the authors [149, 317, 507] who reported the correlation matrices. In the silo approach, the level 2 capital is obtained by summing up the individual capitals for credit, market and operation risk:  $100\% = 50\% + 20\% + 30\%$ . The level 1 capitals are taken fully into account, no diversification is realized. The diversification benefits realized are equal to 28%, 23% and 16%, respectively. With the KSW correlation matrix, the 84% of capital is

<sup>73</sup> Note that this approach assumes that the var/covariance approach holds approximately. It is assumed that the economic capital is equally proportional to the loss standard deviation. It is a strong simplifying assumption that the capital multipliers (eqn 5.10) for different distribution types are approximately the same.



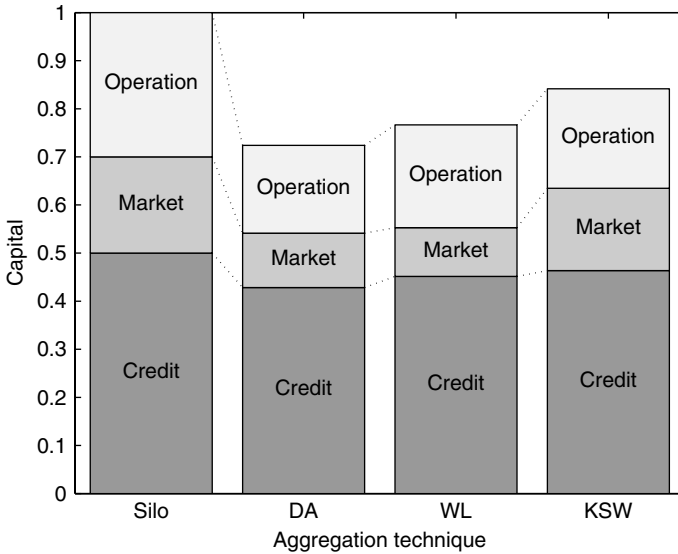

**Fig. 5.20** Capital allocation using different aggregation methods. In the DA, WL and KSL approach [149, 317, 507], the credit risk is weighted with 86%, 90% and 93% in the resulting capital, respectively. For market risk, these weights are 57%, 51% and 86%, while for operation risk they are 61%, 71% and 69%, respectively.

obtained by weighting credit, market and operation risk with the risk contributions of 93%, 86% and 69%, respectively. The 84% of capital with respect to the silo approach is obtained as the weighted sum of the individual capital amounts:  $50\% \times 93\% + 20\% \times 86\% + 30\% \times 69\%$ . Observe that for credit and market risk, the weights are close to 100%. The difference with the silo approach is rather small. The level 2 diversification benefits are smaller on level 2 than on level 1.

For the life insurance company described in the previous section, the WL and KSW correlations for Table 5.5b allow realization of a diversification benefit of 28% or 18%, respectively. The P&C and diversified composite insurance obtains a diversification benefit of 28% or 26%. For the diversified insurer, the result is larger in the WL case 35%, while in the KSW case it is 25%. The differences between the diversification benefits are explained by the higher correlations in the KSW case.

### Level 3

Risk is aggregated across different business lines. The diversification benefit is realized by combining a bank with an insurance company or a securities house. At this level, there are fewer risk factors. The few risk factors are likely to be correlated, a.o., because of the same dependence on the business

**Table 5.5** Reduced correlation matrices between credit, market, operation P&C and life risk from different sources DA [149], WL [507] and KSW [317].

<b>DA</b>	Crdt	Mrkt	Op.	<b>WL</b>	Crdt	Mrkt	Op.	<b>KSW</b>	Crdt	Mrkt	Op.
Crdt	100%	30%	20%	Crdt	100%	30%	44%	Crdt	100%	80%	40%
Mrkt	30%	100%	20%	Mrkt	30%	100%	13%	Mrkt	80%	100%	40%
Op.	20%	20%	100%	Op.	44%	13%	100%	Op.	40%	40%	100%

(a) Bank intracorrelations

<b>WL</b>	Crdt	Mrkt	Op.	P&C	Life	<b>KSW</b>	Crdt	Mrkt	Op.	P&C	Life
Crdt	100%	30%	20%	0%	0%	Crdt	100%	80%	40%	20%	10%
Mrkt	30%	100%	20%	20%	0%	Mrkt	80%	100%	40%	20%	10%
Op.	20%	20%	100%	20%	20%	Op.	40%	40%	100%	20%	10%
P&C	0%	20%	20%	100%	0%	P&C	20%	20%	20%	100%	10%
Life	0%	0%	20%	0%	100%	Life	10%	10%	10%	10%	100%

(b) Insurance intracorrelations

cycle. The correlation is expected to be lower when the companies are located in different economies.

The diversification effect is often limited by practical constraints. For example, the choice of the subsidiary size is limited by various issues. The diversification effect is illustrated for a bank combined with one of the 3 insurer types in Fig. 5.21. The diversification benefit is calculated using the KSW bank and insurance intracorrelation matrices, and with between business line intercorrelations put at 90% relative of the in-between intracorrelations [317]. The largest diversification benefit is obtained by combining a bank with a P&C insurance company. A partial explanation is the low correlation between credit and P&C risk, both are important elements of bank and insurance risk. Note that the diversification benefit on level 3 is small compared to level 1 and 2 diversification.

Diversification and risk-return optimization are a main driver of mergers and acquisitions on top of economies of scale and scope and strategic expansions. The composition of a financial conglomerate and the selection of the business lines (sector, location) is targeted to optimize the return of a given level of risk or to optimize risk for a given return. One needs to define the selection and the weight of the different business lines in the conglomerate. A related problem occurs in portfolio composition problems of bonds, stocks and other securities.

When one makes the (big) simplification that the risk is sufficiently measured by the standard error or variance of the return, the optimal combination lies upon the mean-variance efficient frontier. The efficient frontier depicts all portfolios with maximum possible return for a given level of risk

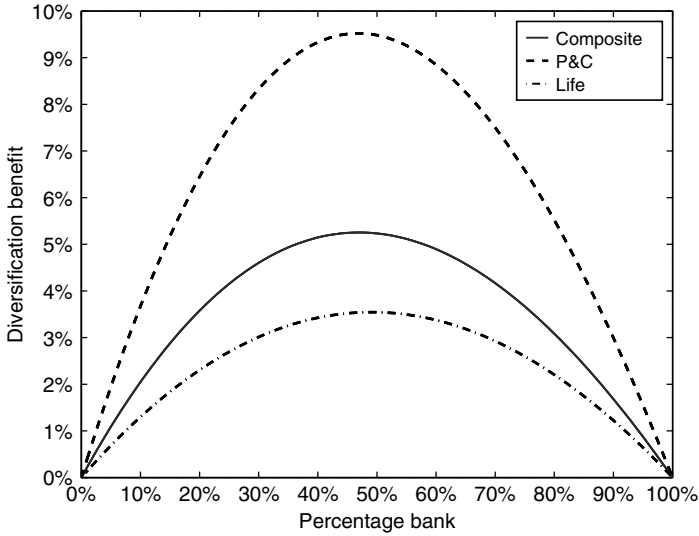

**Fig. 5.21** Level 3 diversification benefit of a bank with an insurance company. The percentage of the bank capital on a stand-alone basis in the group is depicted on the x-axis. The diversification is the highest for the combination of a bank with a P&C insurance company.

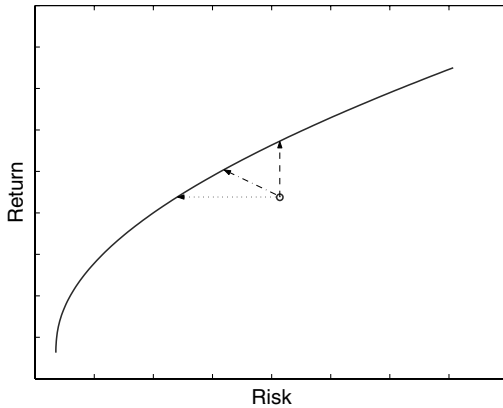

**Fig. 5.22** Mean-variance efficient frontier for combining bank and insurance companies. A given institution’s risk-return (indicated by “o”) may not be at the efficient frontier, one can either choose to increase return (dashed arrow), reduce risk (dotted arrow) or both (dashed-dotted arrow).

(Fig. 5.22). The efficient frontier contains all efficient portfolios. A portfolio is efficient when it has the lowest possible risk or variance amongst all possible portfolios with the same return [210, 343]. Typically, other constraints mean that the bank is not efficient. By changing the focus of the investment

strategy, the bank can move to the efficient frontier either by keeping its risk profile and increasing the expected return, by reducing the risk for the given return, or by a combination of both. New financial products (securitization, credit derivatives, . . .) provide more flexibility to reach the frontier. When using only the mean and variance information, the solution of the efficient frontier follows from a quadratic programming problem. For conglomerates with different types of risk distributions, the calculation of the efficient frontier is more complex and the mean-variance approximation is less appropriate. For earnings-at-risk computations that go less far in the tail of the distribution, the mean-variance approximation will be more reliable.

#### 5.9.4 Capital allocation

Once the capital is determined at the holding level, one allocates it to the different business lines and the products that cause the risk. The capital allocation takes into account the risk position of the business line and the diversification benefit it realizes in combination with the other business lines.

The holding or group level capital is allocated to the  $n$  different business lines such that the business lines (BL) capital sums up to the holding level capital

$$\begin{aligned} EC(\text{Group}) &= rc_1 EC^{\text{SA}}(\text{BL}_1) + rc_2 EC^{\text{SA}}(\text{BL}_2) + \dots + rc_n EC^{\text{SA}}(\text{BL}_n) \\ &= EC^{\text{AL}}(\text{BL}_1) + EC^{\text{AL}}(\text{BL}_2) + \dots + EC^{\text{AL}}(\text{BL}_n). \end{aligned}$$

The allocated capital ( $EC^{\text{AL}}$ ) is obtained as the risk contribution ( $rc$ ) times the stand-alone capital ( $EC^{\text{SA}}$ ). The weighted sum of the stand-alone capital yields the group capital. The allocated capital to each business line allows comparison of the risk level of each business line to its return. Such performance measures are discussed in the next section. Within each business line, the capital can be allocated to individual securities to make investment decisions.

There exist many ways to allocate the capital, both on the calculation of the risk contribution and the stand-alone capital definition. The pro-rata approach assigns the capital in proportion to the stand-alone capital requirements. The pro-rata approach distributes the group capital amongst the different business lines or products proportional to the individual risk measure:

$$EC^{\text{AL}}(\text{BL}_i) = \frac{EC^{\text{SA}}(\text{BL}_i)}{\sum_j EC^{\text{SA}}(\text{BL}_j)} \times EC(\text{Group}).$$

### 340 Portfolio models for credit risk

The capital allocation does not take into account diversification benefits. Consider the universal bank of Fig. 5.20 with the KSL correlation matrix. The 84% group capital is distributed to credit risk (42%), market risk (17%) and operation risk (17%) by multiplying the group capital with the stand-alone capital proportions of 50%, 20% and 30%, respectively. In the variance/covariance approach, one computes the risk contributions such that the resulting variance of the group portfolio is obtained. From eqn 5.4 the risk contribution is obtained as

$$rc_i = \frac{EC^{SA}(BL_i)}{EC(\text{Group})} \sum_{j=1}^n EC^{SA}(BL_j) \rho_{ij}.$$

The risk contribution,  $rc$ , measures the correlation of the business line with the whole portfolio as in the calculation for the marginal loss standard deviation (eqn 5.7). The higher the correlation, the higher the risk contribution. For the universal bank of Fig. 5.20, the risk contributions for credit, market and operation risk are equal to 93%, 86% and 69%, respectively. Because operation risk is less correlated with the total portfolio, it has a lower risk contribution. The 84% group capital is obtained as  $50\% \times 93\% + 20\% \times 86\% + 30\% \times 69\%$ . More generally, the allocation is done according to Euler's lemma. Consider a portfolio with  $n$  assets  $A_i$ , then the capital contributions are obtained from:

$$EC(A_1 + \dots + A_n) = \sum_{i=1}^n A_i \frac{\partial EC(A_1 + \dots + A_i + \dots + A_n)}{\partial A_i}. \quad (5.51)$$

A more extensive review of capital allocation techniques is provided in book II.

Some subsidiaries have more or less capital than required by the allocation scheme. Techniques exist to distribute capital excesses and shortages in business lines as loans and debt in the whole organization [133]. The capital calculation at the holding should avoid double leverage; when capital at a daughter company is used as a buffer for the risk positions of the daughter, this needs to be taken into account when computing the buffer capital for other risks taken elsewhere in the conglomerate structure.

Capital allocation is a sensitive task in the organization. Especially when the results are used for strategic and investment decisions, the calculation method may have important differences for some business lines. Apart from the methodological choice, the parameter estimates may also impact the resulting risk contributions and capital charges. This has been illustrated, e.g., by the impact of the different correlation matrices reported in Table 5.5.

Because most correlations are measured on limited data history, the parameter sensitivity has to be carefully analyzed and stabilization techniques are required before the actual application of such techniques.

### 5.9.5 Risk-adjusted performance measures

Initially, the performance of a bank was based on the revenues or earnings. The accountancy measure was common practice by banks until the 1970s. Banks increased their revenues by focusing on asset growth. An increased leverage yields higher return as explained in Fig. 1.3. However, such a measure lacks the relation with a reference asset to compare banking performance. Later, return on assets (ROA) became a popular measure. Because of the growing importance of off-balance sheet products and different risk of assets, return on equity (ROE) became the key performance measure. The explicit relation between equity and risk in regulation, changed the emphasis of accountancy equity to risk capital for the comparison measure. The return is related to economic capital and risk-based capital measures.

Risk-adjusted performance measures (RAPM) determine the profitability by comparing the earnings of the bank, a business line or a transaction to the economic capital. Like for firms, where one compares return on equity (ROE), returns from banking activities are compared to the risk or economic capital<sup>74</sup> that they consume. The best-known performance measure is risk-adjusted return on capital (RAROC). It was developed by Bankers Trust in the late 1970s. RAROC has become a generic term for risk-adjusted performance measures.

The performance measure has to satisfy the intuitive constraint that when a single facility  $A_i$  performs better than the whole portfolio  $A_1 + \dots + A_n$ , i.e.  $\text{RAROC}(A_i) > \text{RAROC}(A_1 + \dots + A_n)$ , then the RAROC of the full portfolio should increase when the importance of  $A_i$  is increased:

$$\begin{aligned} & \text{RAROC}(A_1 + \dots + A_i + \delta A_i + \dots + A_n) \\ & > \text{RAROC}(A_1 + \dots + A_i + \dots + A_n), \end{aligned}$$

where the inequality should hold at least for sufficiently small  $\delta A_i$ . For large changes  $\delta A_i$ , it does not necessarily hold, e.g., because of increasing concentration risk.

<sup>74</sup> The risk capital that a transaction consumes is defined by regulation or internal risk management rules. It differs from the common equity in the sense that other products like perpetual debt are also considered as capital for regulatory calculations. An overview of the capital elements is given in section 6.2.

**Definition**

The generic definition of RAROC is

$$\begin{aligned} \text{RAROC} &= \frac{\text{Risk-adjusted net income}}{\text{Economic capital}} \\ &= \frac{\text{Revenues} - \text{Costs} - \text{EL} \mp \text{Other}}{\text{Economic capital}}. \end{aligned} \quad (5.52)$$

The risk-adjusted net income equals the revenues minus costs and the expected loss. For a straight loan, the revenues come from the credit rate. For more complex products, revenues can consist both of charged interests and commission fees. The costs include the funding and financing costs for the bank borrowing the money on the financial markets, and operational costs like marketing, personnel, renting, and IT costs. Taxes are an example of other elements in the numerator.

There are many implementations and interpretation of the RAROC formula [348]. The differences are the interpretations of revenues, costs and even the economic capital. Costs can include various elements of the P&L statement of Table 1.2: non-interest expenses like personnel, infrastructure and marketing costs; funding costs or interest expenses for a similar maturity. Revenues include interest revenues and administration fees.

The risk-adjusted net income is compared with the economic capital that the business line or product consumes. As explained above, the choice of the economic capital allocation method will impact the resulting RAROC. In some applications, the decision is made based upon a combination of regulatory and economic capital in the denominator.

A simple alternative is the return on risk-adjusted capital (RORAC) that compares the return to the economic capital. To mention explicitly the use of a risk-based economic capital measure, one also uses the term RARORAC: risk-adjusted return on risk-adjusted capital.

It is interesting to compare the RAROC with a classical RAPM. The Sharpe ratio is defined as follows [440, 441]:

$$\text{Sharpe ratio} = \frac{\text{expected return} - \text{risk free rate}}{\text{return volatility}} = \frac{\mathbb{E}(r) - r^*}{\sigma_r}.$$

For a given investment with return  $r$ , one compares the expected return  $\mathbb{E}(r)$  to the risk free rate  $r^*$ . In the “reward-to-variability” ratio, the difference is the excess return  $\mathbb{E}(r) - r^*$ , which is compared to the uncertainty on the return  $\sigma_r = \mathbb{V}(r)^{1/2}$ , which is a measure of the risk. Other measures

use the capital assets pricing<sup>75</sup> model's (CAPM's)  $\beta$  in the denominator (Treynor ratio [480]) or a downside volatility (Sortino ratio [451]). Compared to RAROC-based measures, these measures compare return to individual volatility or risk, not to the risk in the global portfolio.

### Goals, use and limitations

RAROC is used to measure the profitability of a transaction, business line and the whole bank. On the level of an individual transaction, the RAROC indicates whether the transaction is sufficiently profitable. When the RAROC is lower than the bank's hurdle rate, the investment is not made, when it is above, the transaction is made. For borderline cases, where, e.g., cross-selling is important, investments can be approved that are slightly below the hurdle rate. With RAROC, prices can be made risk-based such that the desired hurdle rate is achieved.

On a portfolio and business-line level, the RAROC is measured to support strategic decision making. One favors portfolios with high RAROC to increase the bank's overall profitability. Bonuses of the business-line managers and relationship managers can be made dependent on the RAROC instead of turnover or total revenues that are not risk-adjusted performance measures. The EC and RAROC framework can also be used for transfer prices when assets are sold from one unit in the bank to another.

The RAROC summarizes risk and revenues in a single indicator. The information reduction has some disadvantages. In most applications, the RAROC horizon is limited to one year. Longer-term risks or revenues may not be well expressed in the one-year RAROC. The RAROC depends on many calibrated values and the methodology chosen to calculate them: risk measurement, performance measurement and capital allocation. When different business lines use different measures, RAROC may not be comparable across business lines. A coherent measurement framework is a necessary condition to make a RAROC implementation successful. The definition of RAROC also has some theoretical limitations, see, e.g., [125]. Despite the deficiencies, an important advantage of the RAROC methodology is that it allows simple horizontal and vertical communication in the organization.

<sup>75</sup> The CAPM [334, 370, 439, 442]  $\mathbb{E}(r_i) = r^* + \beta(\mathbb{E}(r_m) - r^*)$  relates the expected excess return  $\mathbb{E}(r_i) - r^*$  as an asset  $i$  to the market premium  $\mathbb{E}(r_m) - r^*$  via the beta coefficient. This beta coefficient  $\beta_{im} = \text{cov}(r_i, r_m) / \mathbb{V}(r_m)$  indicates the sensitivity of the excess asset return to the market returns. A beta higher than one indicates higher risk than the market, a beta lower than one reflects lower risk.



# 6. Basel II

---

## 6.1 Introduction

The Basel Capital Accord was concluded by the Basel Committee on Banking Supervision (BCBS) on July 15, 1988 in the Bank of International Settlements head office located in Basel [49]. The accord agrees upon a minimal capital regulation framework for internationally active commercial banks so as to reduce the risk of the international financial system. It created a level playing field of homogeneous capital rules for internationally active banks. The capital accord defines a uniform set of rules to calculate the minimum capital levels banks should hold as a buffer to protect their depositors and financial markets in the case of severe unexpected losses due to financial risks. Although it has been subject to criticisms on lack of risk sensitivity and other deficiencies increasing with ongoing financial innovations, the 1988 Capital Accord will remain a milestone in banking regulation. This capital accord has been the basis for national regulation in more than 100 countries, while capital ratios<sup>76</sup> of most banks increased in the early 1990s by either increasing the capital base or reducing credit risk [505].

The 1988 Capital Accord, now called Basel I, initially covered only credit risk. The regulatory capital calculation was based upon a set of simple rules that define the appropriate risk weights of Table 6.2 that have to be applied to a given asset or loan. For example, for a loan to a firm, a risk weight of 100% needs to be applied. The regulatory capital is then obtained as 8% of the exposure of the asset times the risk weight:

$$\text{Capital} = 8\% \times \text{Risk weight} \times \text{Exposure}. \quad (6.1)$$

The product of risk weight and exposure is better known as the “risk weighted assets” (RWA). For an exposure of €1000 on a firm, the required capital is

<sup>76</sup> The capital ratios of large G10 banks increased on average from 9% in 1988 to 11% in 1996.

equal to  $8\% \times 100\% \times \text{€}1000 = \text{€}8$ . For the same exposure to an OECD bank, the required capital  $8\% \times 20\% \times \text{€}1000 = \text{€}1.6$ . The capital of the bank is required to be higher than the regulatory minimum of 8% of the risk weighted assets. Note that for some countries the local regulation may require a higher minimum level.

The total capital for a portfolio is obtained by summing up the regulatory capital for the individual loans. As a result, the risk-based capital adequacy ratio should be equal to or greater than 8%

$$\frac{\text{Capital}}{\text{Total risk weighted assets}} \geq 8\%. \quad (6.2)$$

The more risky the positions of the bank are, the higher are the risk weighted assets and the more capital is charged. The rules of the first Basel Capital Accord came into force in 1992. Note that the capital serves to protect depositors and bondholders in case of default. Although a high capitalization will reduce the default risk, the capital is not calculated to protect the bank against default.

The Basel Capital Accord of 1988 provided rules for the credit portfolio of the bank. The 1996 amendment also provided rules for assessing the market risk of the bank [44, 46]. The revision of the Basel I Capital Accord for credit risk and operational risk started after the 1996 market risk amendment. By an intensive interaction with the industry via consultation papers (CPs), the BCBS gradually refined the rules of the current capital accord. During the process indicated in Table 6.1, several quantitative impact studies (QIS) were performed to gauge the impact of the new rules on the solvency of banks and the banking system. The main items of the Basel II Capital Accord were agreed upon in 2004 and the final capital accord was published in June 2006 [63]:

*International Convergence of Capital Measurement and Capital Standards, A Revised Framework, Comprehensive Version.*

The ICCMCS rules from the BCBS are implemented via local regulations, like, e.g., the Capital Requirements Directive (CRD) in the European Union. Local regulators and legislative bodies implement the rules in local countries. Note that these rules may evolve during time, as the Basel II Capital Accord is considered as an evolutionary process that keeps track with the evolutions in the financial industry.

**Table 6.1** Chronology of the Basel II Capital Accord.

Date	Development process
June 1999	First Consultation Paper (CP1)
July 2000	Quantitative Impact Study 1 (QIS1)
January 2001	Second Consultation Paper (CP2)
April 2001	Quantitative Impact Study 2 (QIS2)
November 2001	Quantitative Impact Study 2.5 (QIS2.5)
October 2002	Quantitative Impact Study 3 (QIS3)
April 2003	Third Consultation Paper (CP3)
January 2004	“Madrid compromise”
June 2004	“New capital framework” publication
December 2004	Quantitative Impact Study 4 (QIS4)
April 2005	Consultation on the trading book review and double default
July 2005	Publication of the trading book and double default
September 2005	Quantitative Impact Study 5 (QIS5)
End 2005	Parallel calculation foundation IRBA
June 2006	Publication of the revised framework [63]
End 2006	Scheduled implementation of standardized approach Scheduled implementation of foundation IRBA IRBA floor 95% Parallel calculation advanced IRBA & AMA
End 2007	Scheduled implementation of advanced IRBA & AMA IRBA & AMA floor 90%
End 2008	IRBA & AMA floor 80%
End 2009	End of transition period, decision on floors

**Table 6.2** Risk weights for Basel I [49].

Risk weight	Asset type
0%	Cash held
0%	Claims on OECD central governments (foreign currency)
0%	Claims on central governments (national currency)
20%	Cash to be received
20%	Claims on OECD banks
20%	Claims on non-OECD banks (<1 year)
20%	Claims on multilateral development banks
20%	Claims on foreign OECD public-sector entities
50%	Residential mortgage loans
100%	Claims on the private sector (firm debt, equity, ...)
100%	Claims on non-OECD banks (≥1 year)
100%	Real estate
100%	Plant and equipment

The Basel II Capital Accord involves an important revision of the rules for credit risk towards higher risk sensitivity as well as greater reliance on the bank's internal expertise, internal historical databases, risk methodologies, models and risk-parameter estimates. In turn, these methodologies require more stringent risk management practices and procedures. The credit risk measurement becomes more sensitive with better differentiation between the capital for different risk grades. Complementary improvements are the recognition of credit risk mitigation techniques like collateral, guarantees, netting and credit derivatives, and the recognition of the importance of diversification across regions and industries. In addition, a framework is provided to hold capital against operational risks. At the same time, the aims of the 1988 Basel I accord to create and maintain a level playing field for internationally active banks, and to maintain and improve stability of the international banking system, remain in the 2006 Basel II accord.

The Basel II rules become active in 2007 and 2008 with a transition period, where large reductions in capital requirements are avoided by a floor on minimum capital requirement during the first years. These floors are applicable for banks adopting the more sophisticated methods like the internal-ratings-based approach for credit risk or the advanced measurement approach for operational risk, as explained below. The floor reduces from 95% to 80% of the Basel I capital requirements as can be found in section 45–48 of [63] and is illustrated in Table 6.1. For example, the capital ratio of an IRBA & AMA bank in mid-2007 has to be higher than 8% based upon the Basel II calculations, while the capital also needs to exceed 90% of the Basel I capital requirements. In a simplified setting, it means that the Basel II capital ratio needs to exceed 8% and that the Basel I capital ratio needs to exceed  $90\% \times 8\% = 7.2\%$ .

The scope of the Basel II framework is defined in the beginning of the capital accord [63]. The capital requirements are calculated on a consolidated basis. It reduces the risk of double-counting effects where the same capital is used twice (or more) to cover different risks. The scope is therefore any holding company that is a parent entity within a banking group as indicated in Fig. 6.1. Such a holding company itself can be part of a parent company to which the scope is not applicable. The Basel II framework also applies to all international banks at every tier within the banking group. Supervisors should test that individual banks are sufficiently capitalized as well because one of the main objectives is to protect depositors with capital that is readily available. To the extent possible, other financial entities are also included,

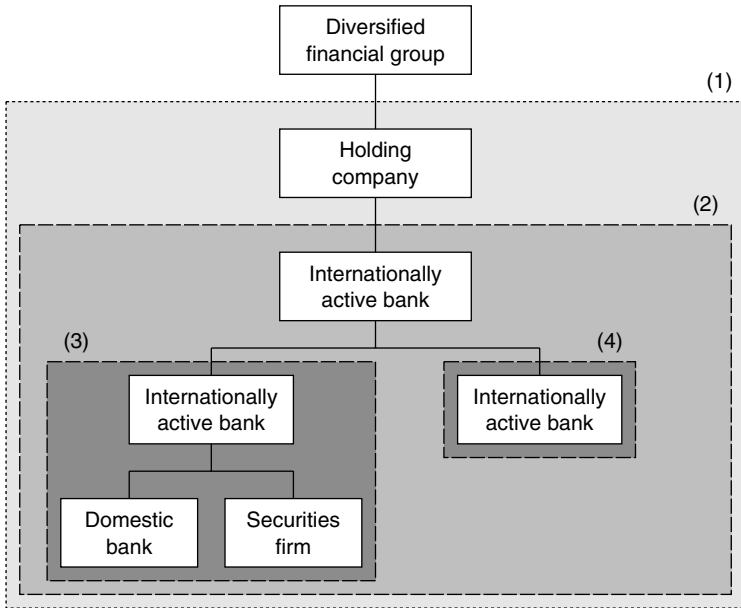
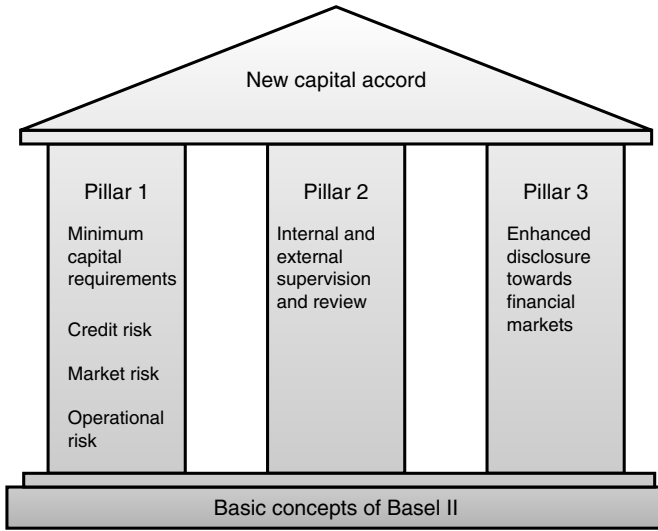

**Fig. 6.1** The scope of the application of the Basel II Capital Accord. The dotted line (1) indicates the boundary of the predominant banking group to which the capital framework is applied on a consolidated basis. The framework is also applicable on lower levels indicated by the dashed lines (2–4) to ensure sufficient capitalization of all internationally active banks in a banking group [63].

but insurance companies<sup>77</sup> are not yet included. The BCBS judged that at this stage it is, in principle, appropriate to deduct the full entrepreneurial risk of the insurance company from the capital of a bank that owns the insurance company. Because of the developments in the regulatory framework for insurance companies, other treatments are defined in section 30–34 [63]. Material investments in commercial entities are deducted from the capital, for other investments the equity risk weights are applied as explained in section 6.3.1.

The new capital adequacy accord is based upon 3 mutually reinforcing pillars depicted in Fig. 6.2: minimum capital requirement, supervisory review and market discipline and reporting. First, the pillar 1 capital calculation for credit, market and operational risk of the Basel II Capital Accord is described in section 6.3, while the capital is described in section 6.2.

<sup>77</sup> Note that for insurance companies a similar regulatory framework as for banks, called Solvency II, is defined.



**Fig. 6.2** Basel II framework with 3 mutually supporting pillars.

The supervisory review process of pillar 2, discussed in section 6.4, verifies whether the bank holds sufficient capital, above the pillar 1 minimum capital level, for all its risks. The market discipline of pillar 3 is summarized in section 6.5. The information and communication technology (ICT) challenges for implementing a uniform and consistent firm-wide risk management are discussed in section 6.6. This chapter is concluded with a discussion on the market impact of the Basel II Capital Accord for creditors and borrowers in section 6.7 and a discussion on future evolutions in section 6.8.

For more details, the documentation, guidelines and reports of the Basel Committee on Banking Supervision can be downloaded from the website of the Bank of International Settlements ([www.bis.org](http://www.bis.org)). This chapter provides a concise overview of the Basel II Capital Accord [63] and indicates where the statistical techniques of books II and III are applicable. There exists a large list of books specifically on Basel II, a.o., [37, 166, 224, 275, 381, 422, 485].

Readers who will not deal with the technical implementation of Basel II are advised to read sections 6.2–8, and to consult the technical parts in sections 6.3.1–3, 6.4.1–5, and 6.5.2 in the case of specific questions. Readers who will deal with the technical implementation of Basel II are advised to read comprehensively sections 6.2–8 as well as the technical part they are

working in. They are advised to skim the other technical parts of sections 6.3.1–3, 6.4.1–5, and 6.5.2 in order to get a good overview of the new Basel II Capital Accord.

## **6.2 Bank capital**

A bank needs to hold capital to absorb unexpected losses and protect the bank's debt holders, e.g., savings deposits. Provisions, reserves and current-year profits need to cover the expected losses. Different types of capital exist that have varying seniority levels to absorb losses. The capital accord and local regulation determine which capital types are eligible for regulatory capital requirements and the calculation of the capital ratio, eqns (6.1) and (6.2).

### **6.2.1 Tier 1 capital**

From a regulatory perspective, Tier 1 capital is the core measure of a bank's financial strength. The Tier 1 capital consists of the most reliable capital when appealed to in adverse circumstances. Apart from being reliable, it is also very liquid. Common stock, preferred stock and retained earnings are key elements of Tier 1 capital. The notion of capital is related to the accountancy concept of shareholder's equity. It is not the stock market value of the equity, but the accounting value. If one starts a bank with €10 that makes each year a profit of €1 that is retained in the bank, the shareholder's equity is €15 after 5 years.

The Tier 1 capital was defined in the Basel I Capital Accord. Its definition was not changed in the Basel II Capital Accord. The local regulator has the discretion on the precise definition of eligible capital for Tier 1 according to the local legal framework. On top of the above-mentioned key elements, other elements like minority interests may also be included subject to restrictive conditions. A complete list is available from [43, 63].

The solvency of the bank in a regulatory capital context is often compared to its risk profile expressed by the risk weighted assets. The Tier 1 capital ratio compares the Tier 1 capital to the risk weighted assets. The Basel Capital Accord requires the ratio to be above 4%.

Deductions from the capital include goodwill and material investments in non-financial entities. Goodwill is at 100% deducted from Tier 1 capital. Non-financial investments are deducted for 50% from Tier 1 capital and for 50% from Tier 2 capital. The expected loss for equity investments under

the PD/LGD approach is also deducted. In the IRB approach for other asset classes, if the expected loss exceeds the general provisions or loan-loss reserves, the difference is subtracted for 50% of Tier 1 capital and 50% of Tier 2 capital.

The Tier 1 capital determines a maximum level of 15% innovative capital elements for Tier 2 and 3 capital as specified in Annex 1 of [63]. The limits of Tier 1 are calculated after deduction of goodwill but before deductions of investments.

### 6.2.2 Tier 2 capital

Tier 2 capital is the second most reliable form of capital that a bank holds against unexpected losses. Tier 2 supplementary capital was defined in the Basel I Capital Accord and is implemented into local legislation by the local regulators that may adjust the eligible Tier 2 capital definition to the local legislation and banking environment. The Basel I Capital Accord describes the following types of Tier 2 capital:

**Undisclosed reserves:** Undisclosed reserves occur when a bank has made a profit, but where this has not appeared in normal retained profits or in general reserves.

**Revaluation reserves:** Revaluation reserves are created when the bank has an asset of which the value increase in the revaluation process is taken into account. A typical example of a revaluation is an office space at a popular location that has increased a lot in value due to increasing real estate prices.

**General provisions:** A general provision is created when a bank is aware of a loss, but is not sure yet of the exact nature of that loss. Before IFRS/IAS, general provisions were used to buffer for future unidentified losses that were expected in the future. Because provisions did not cover a specific incurred loss, many regulators accepted to count these provisions as capital.

**Hybrid instruments:** Hybrid instruments have features of debt and shareholders' equity. In the case where such instruments can absorb losses on the face value like equity without invoking a liquidation of the bank, such hybrid instruments are eligible for the capital calculation.

**Subordinated term debt:** Subordinated term debt is subordinated to other debt types that are more senior (e.g., saving deposits). In the case of a default, the junior or subordinated debt holders will not get paid until



the senior debt holders are paid in full, following the pecking order of the debt. Subordinated debt is restricted to 50% of Tier 1. A minimum remaining maturity of 5 years is required, for shorter-term debt a haircut is applied.

The total capital ratio compares the Tier 1 core capital and the Tier 2 supplementary capital to the risk weighted assets. In Basel I and II, this ratio has to be above 8% at a minimum level. Local regulation may require a higher level.

Under the Basel II Internal Ratings Based Approach (IRBA), the treatment of the 1988 Accord to include general provisions (or general loan-loss reserves) in Tier 2 capital is withdrawn. If IRB banks have a higher expected loss than the general provisions, the 50% of the difference is subtracted from Tier 2 capital as discussed above. If the general provisions exceed the expected loss, one can take into account the difference capped at 0.6% of the risk weighted assets. The amount of Tier 2 capital is limited to 100% of Tier 1 capital.

### **6.2.3 Tier 3 capital**

The concept of Tier 3 capital was introduced for market risk. The time horizon for this risk is much smaller. Gains and losses are realized and absorbed on a much smaller time horizon. This capital is unsecured, subordinated and fully paid up, it has a smaller maturity of at least 2 years and is not repayable before the repayment date unless the supervisor agrees, and it has to be able to absorb losses (e.g., clauses of non-dividend payments, . . .). The amount of Tier 3 capital is limited to 250% of the Tier 1 capital that is used to cover market risk. The practical calculation of Tier 3 capital is subject to complex rules available from the regulators.

For the calculation of the capital ratio, one uses all the available Tier 1 and Tier 2 capital, but only the amount of used Tier 3 capital.

### **6.2.4 Deductions**

From the total capital, one needs to make several deductions:

**Goodwill:** Goodwill is deducted 100% from Tier 1 capital.

**Securitization equity:** High-risk securitization exposures are considered as equity investments and are deducted from capital (Table 6.6). Deductions are made 50% from Tier 1 and 50% from Tier 2 capital.

**Investments in non-consolidated banks and financial activities:** Equity capital in banks and financial firms serves as a capital buffer to protect customers and depositors. When these investments are not consolidated on the level of the investing bank, these equity investments can no longer be counted as capital to prevent multiple use of the same capital in different parts of the group. Such multiple use is called double leverage and is avoided by regulators because in the case of a crisis of the bank system there would be insufficient capital to protect both the customers of the non-consolidated subsidiary and the parent entity. Because of double leveraging, a crisis in one bank could spread rapidly across the whole financial system. Deductions are made 50% from Tier 1 and 50% from Tier 2 capital.

**Investments in insurance entities:** Capital rules for insurance companies are not yet harmonized with bank capital rules. Capital for insurance companies is considered to protect policy holders. As such, recognizing insurance investments as equity would trigger double leverage. Therefore, the BCBS considers that investments in insurance subsidiaries and significant minority investments in insurance companies should be deducted from capital, up to the national discretion of supervisors and differences between insurance surplus equity and regulatory capital. Deductions are made 50% from Tier 1 and 50% and Tier 2 capital.

**Investments in commercial entities:** Banks may hold equity investments in commercial entities for various reasons. Such investments are taken into account via capital requirements as long as materiality thresholds are not exceeded. Investments that exceed materiality thresholds are deducted from capital. Materiality thresholds are determined by national accounting and/or regulatory practices. Materiality thresholds of 15% for individual investments and 60% for aggregate commercial investments are mentioned in section 35 [63]. Deductions are made 50% from Tier 1 and 50% and Tier 2 capital.

Note that exceptions and further limitations to the double leveraging are left to the discretion of national supervisors and may evolve over time.

### 6.2.5 Bank capital management

The above elements and the capital aspects of the previous Chapter can be summarized into the different perspectives on capital management as

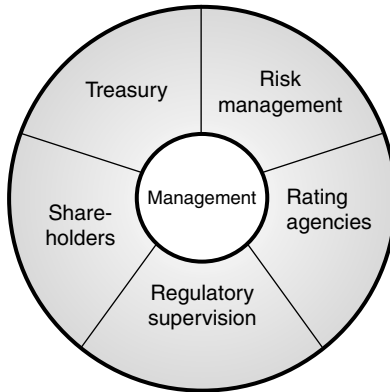

**Fig. 6.3** For the bank capital management, the bank's management needs to balance between regulatory, agencies', shareholders', risk management and treasury requirements.

indicated in Fig. 6.3 [348]. The regulator expresses minimum capital requirements to ensure sufficient capitalization of the bank and to protect saving deposits. The regulator defines rules that determine the amount of capital that is needed for a given measured risk level, and defines which capital is eligible to determine the regulatory capital base. Agencies will reward more capital, *ceteris paribus*, with a better rating. A better rating reduces funding costs.

From a risk manager's perspective, the amount of bank capital is necessary to absorb high losses in adverse circumstances. The amount of capital is determined at a high confidence interval of the loss distribution. The shareholders are interested in a good balance between capital and return as discussed in the section on economic capital of the previous chapter. The treasurer is responsible for determining the amount of capital available and to raise funds when necessary. He chooses between different product types to raise sufficient capital. The treasurer manages the capital base.

### 6.3 Pillar 1 (minimum capital requirements)

Pillar 1 describes the rules to calculate and report the minimum regulatory capital standards for credit, market and operational risk. Compared to the 1998 Capital Accord, the new requirements aim to better align economic and regulatory capital requirements; reducing incentives for regulatory arbitrage [287].

The regulatory capital is computed as the sum of the credit, market and operational risk capital charge (CC). The capital charge corresponds to the risk weighted assets via a factor 12.5

$$\text{Risk weighted assets (RWA)} = 12.5 \times \text{capital charge (CC)}.$$

The capital requirements will be gauged by the total capital coefficients

$$\frac{\text{Capital}}{\sum \text{Credit RWA} + 12.5 \times (\sum \text{Market risk CC} + \text{Oper. risk CC})} \geq 8\%,$$

or

$$\frac{\text{Capital}}{\text{RWA}(\text{Credit risk}) + \text{RWA}(\text{Market risk}) + \text{RWA}(\text{Oper. risk})} \geq 8\%. \quad (6.3)$$

The capital coefficient must amount to at least 8%. The innovations of the new capital accord relate mainly to improvements in the risk measurement, i.e. in the computation of the denominator:

**Credit risk:** The credit risk charge can be calculated in three ways: the standardized approach, the foundation internal-ratings-based approach and the advanced internal-ratings-based approach with increasing risk sensitivity. The calculation of exposure and the impact of collateral and risk mitigation is also assessed in different ways. The credit risk framework is discussed in section 6.3.1.

**Market risk:** The market risk charge is calculated using the standardized approach or the internal model approach as set out in the 1996 amendment. It allows a standardized approach, but an incentive is given to apply the internal models approach. The market risk framework is reviewed in section 6.3.2.

**Operational risk:** The regulatory capital for operational risk is computed either by the basic indicator approach, the standardized approach, or the advanced measurement approach with increased complexity and risk sensitivity. The operational risk framework is reviewed in section 6.3.3.

The standardized approaches are less risk sensitive and determine conservative average risk levels for an average bank. Internal approaches allow banks to measure their own risk levels within the regulatory framework. It allows a higher risk sensitivity in the capital requirement. Because it allows determination of the capital requirement more precisely, the resulting capital levels tend to be less conservative for an average bank. An overview

**Table 6.3** Different approaches to measure credit, market and operational risk (pillar 1). The section where the capital framework is summarized is indicated in the last column.

Risk category	Measurement approach	section
Credit risk	Standardized approach	6.3.1.1
	Foundation internal-rating-based approach	6.3.1.2
	Advanced internal-rating-based approach	6.3.1.2
Market risk	Standardized approach	6.3.2.1
	Internal models approach	6.3.2.2
Operational risk	Basic indicator approach	6.3.3.1
	Standardized approach	6.3.3.2
	Advanced measurement approach	6.3.3.3

of the approaches to calculate regulatory capital is given in Table 6.3. Compared to the Basel I Capital Accord, the main changes are the introduction of operational risk and the important changes in credit risk. The latter is possible due to the increased level of sophistication of risk management and measurement techniques. As this level may vary across financial institutions, both standard and advanced risk measurement methods are provided.

The regulation for the 3 risk types is reviewed below in sections 6.3.1–6.3.3. The last column of Table 6.3 indicates the sections where the different approaches are described. The emphasis is put upon the rules for credit risk<sup>78</sup> that is detailed further in Table 6.5. Note that some parts of this chapter are very enumerative, which is an inconvenience inherent to most technical regulations and documentations. Overview Tables 6.3–6.5 serve as high-level road maps through the many different topics.

### 6.3.1 Credit risk (pillar 1)

The credit risk can be measured using 3 approaches as explained in Table 6.4: the standardized approach, the foundation internal-ratings-based approach and advanced internal-rating-based approach. The more advanced the approach, the higher is the responsibility and the implementation cost

<sup>78</sup> Note that the BCBS regulation may evolve over time and can be adjusted by local regulators. Therefore, it is recommended to consult your local regulation when implementing regulatory parameters and formulae into bank systems, calculation engines and reports, instead of copying values reported in this chapter dating from [63].

for the bank. An overview of the different approaches and the different asset classes is given in Table 6.5.

Once a bank chooses to apply an internal-ratings-based approach for a part of its portfolio, it is expected to extend it across the whole banking group. However, some exceptions are foreseen by regulations:

**Roll-out plan:** Because it may not be feasible to implement the IRB approach for all asset classes across all business units at the same time, banks can agree with their supervisors upon a phased roll-out plan across the banking group. Such a roll-out plan schedules the adoption of the IRB across significant asset classes, across business units and the evolution from foundation to the advanced approach for certain risk components.

**Partial use:** For exposures in non-material business units and asset classes, the implementation of the IRB approach may not be cost efficient. On condition that these exposures are immaterial in terms of the size of the exposure and in terms of the risk level, regulators may approve the use of a simpler approach for such exposures. As such, a partial use of standardized, foundation and advanced IRB approaches in the same institution can be allowed. Note that the capital charge for equity exposures in the IRB approach is significantly higher than under the standardized approach. However, also note that equity exposures are excluded from partial use (section 260 in [63]). The interpretation of the partial use can vary across local regulators.

Note that banks are expected to evolve from a standardized approach to the foundation and advanced IRB approach. The foundation IRB approach is considered as an intermediate state. A voluntary return to a less sophisticated approach is not allowed. It can only be allowed by the supervisor in extraordinary circumstances, e.g., when one stops a certain business and divests a large fraction of the bank's assets in that business line.

### **6.3.1.1 Standardized approach (SA)**

The standardized approach is a further sophistication of the Basel I Capital Accord with a finer classification of the credit risk. The measurement of the credit quality is determined by an External Credit Assessment Institution (ECAI) explained in section 3.7. The risk weights for the standardized approach for the different asset classes are summarized in Table 6.6. Using the external ratings, it is seen that the risk weights are more sensitive to the

**Table 6.4** Basel II credit risk parameters for the 3 approaches. The more advanced the approach, the higher is the responsibility of the bank to determine the risk parameters.

	Standardized	IRBA foundation	IRBA advanced
<b>RWA</b>	Basel II lookup table	Basel II formula	Basel II formula
<b>PD</b>	implicit from table	bank estimate	bank estimate
<b>LGD</b>	implicit from table	Basel II estimate	bank estimate
<b>CCF</b>	Basel II estimate	Basel II estimate	bank estimate
<b>CRM</b>			
Collateral	financial collateral	eligible IRBA collateral	bank motivated
Netting	allowed	allowed	allowed
Guarantees	sovereign and banks rated equal or above A–	sovereign, banks and companies equal or above A–	bank motivated
Credit der.	allowed	allowed	allowed
<b>M</b>	Basel II estimate	Basel II estimate	bank estimate

risk than before, where, e.g., a flat 100% risk weight for firm exposures was applicable.

The regulatory risk weights for the different asset classes are discussed in section 6.3.1.1.A. Implementation aspects are summarized in section 6.3.1.1.B. The important concept of risk mitigation is reviewed in section 6.3.1.1.C.

#### 6.3.1.1.A Regulatory risk weights (SA)

The risk weights for the various asset classes are described in [63]. The main elements are summarized in the section below. For banks that do not have the intention to spend a lot of resources to the Basel II implementation, Appendix 9 of [63] provides an overview of the simplest options in the standardized approach.

**6.3.1.1.A.1 Sovereigns and central banks** The Basel I Capital Accord assigns a zero risk weight to OECD<sup>79</sup> member countries. Non-member countries received a risk weight of 100%. In the Basel II Capital Accord, the rating depends upon the ECAI rating. The highest ratings (AAA to AA–) receive a zero risk weight, the lowest ratings (CCC and lower) a risk weight of 150%. The risk weights are assigned to rating categories as can be seen

<sup>79</sup> The member list of the Organization for Economic Cooperation and Development can be retrieved from the website ([www.oecd.org](http://www.oecd.org)).

**Table 6.5** Supervisory approaches and exposure categorization for credit risk. The 5 regulatory asset classes are sovereigns, banks, firms, retail and equities. Securitization exposures are discussed separately in the Basel II Capital Accord.

Sovereigns	Banks	Firms	Retail	Equities	Securitization
<b>Regulatory Approach</b>					
Standardized approach Section 6.3.1.1.A.1	Standardized approach Section 6.3.1.1.A.2	Standardized approach Section 6.3.1.1.A.3	Standardized approach Section 6.3.1.1.A.4	Standardized approach Section 6.3.1.1.A.7	Standardized approach Section 6.3.1.1.A.5
IRBA foundation Section 6.3.1.2.B.1	IRBA foundation Section 6.3.1.2.B.1	IRBA foundation Section 6.3.1.2.B.1		Market-based IMA&RW Section 6.3.1.2.B.3	Ratings-Based Approach Section 6.3.1.2.B.5
IRBA advanced Section 6.3.1.2.B.1	IRBA advanced Section 6.3.1.2.B.1	IRBA advanced Section 6.3.1.2.B.1	IRBA advanced Section 6.3.1.2.B.2	IRBA foundation Section 6.3.1.2.B.3	Internal Ass. Approach Section 6.3.1.2.B.5  Supervisory Formula Section 6.3.1.2.B.5
<b>Exposure categorization</b>					
Sovereigns	Banks	Large Firms	Revolving Retail	Equity investments	Asset-Backed Securities
National Banks	Regulated securities	Small and Medium	Residential Mortgages	Tier 1 instruments	Collateralized Debt Obligations
Internat.organizations	Firms	Enterprises	Other Retail		
	Multilateral Development Banks Public Sector Entities		Purchased Receivables		
		Specialized Lending Project Finance Object Finance Income-Prod. Real Estate High-Volatility Comm. Real Estate			



from Table 6.6. In addition to ECAI ratings, supervisors may recognize the country risk scores of export credit agencies (ECAs) that follow the OECD methodology. Scores 0 to 1, 2, 3, 4 to 6 and 7 correspond to rating zones AAA to AA–, A+ to A–, BBB+ to BBB–, BB+ to B– and CCC, respectively.

Central banks and other international institutions follow the same scheme. Some international organizations and multilateral development banks that comply with the BCBS criteria receive a zero risk weight, like the International Monetary Fund, the Bank for International Settlements, the World Bank and the European Commission. The risk weight is evaluated on a case-by-case basis and is reviewed regularly.

Exposures of banks to their sovereign of incorporation denoted in local currency may be assigned a lower risk weight. The same risk weight can be decided by other national supervisors for claims of their banks concerning domestic currency claims to that sovereign.

**Table 6.6** Risk weights in the standardized approach for Basel II [63].

Rating	Sov.	Banks (Opt.2 ST)	Banks (Opt.1)	Banks (Opt.2 LT)	Corp.	Securit.
AAA	0%	20%	20%	20%	20%	20%
AA+	0%	20%	20%	20%	20%	20%
AA	0%	20%	20%	20%	20%	20%
AA–	0%	20%	20%	20%	20%	20%
A+	20%	50%	50%	20%	50%	50%
A	20%	50%	50%	20%	50%	50%
A–	20%	50%	50%	20%	50%	50%
BBB+	50%	100%	50%	20%	100%	100%
BBB	50%	100%	50%	20%	100%	100%
BBB–	50%	100%	50%	20%	100%	100%
BB+	100%	150%	100%	50%	100%	350%
BB	100%	150%	100%	50%	100%	350%
BB–	100%	150%	100%	50%	100%	350%
B+	100%	150%	100%	50%	150%	deduct.
B	100%	150%	100%	50%	150%	deduct.
B–	100%	150%	100%	50%	150%	deduct.
CCC	150%	150%	150%	150%	150%	deduct.
Unrated	100%	100%	50%	20%	100%	

Non-central government public sector entities follow the approach for banks without the preferential treatment for short-term claims. Certain domestic public sector entities may be treated as sovereigns, in whose jurisdiction the public-sector entities are established. This choice is subject to national discretion.

**6.3.1.1.A.2 Banks** Banks that are incorporated in an OECD member country received a risk weight of 20% in the Basel I Capital Accord. Other banks received a risk weight of 100%. Under Basel II, national supervisors can choose between two options. Under option 1, claims on a bank are assigned a risk weight one category less favorable than that of the sovereign of its domiciliation (Table 6.6). The risk weight depends on the rating of the sovereign, not of the bank. Under option 2, a bank receives the risk weight corresponding to its external credit assessment for long-term (LT) positions. Low-risk and short-term (ST) positions with an original maturity less than 3 months receive a lower risk weight. An unrated bank cannot receive a risk weight lower than applied to the sovereign.

Claims on securities firms receive the risk weight of banks when these firms are subject to a similar regulatory framework. Otherwise, securities firms follow the risk weight for firms.

**6.3.1.1.A.3 Firms** Firm claims were assigned a risk weight of 100% independent of the credit quality in Basel I. Basel II assigns a risk weight to firms (including insurance companies) that depends upon the rating. The risk weight ranges from 20% to 150% as reported in Table 6.6. The risk weight for a firm cannot be lower than the risk weight of the sovereign of incorporation.

**6.3.1.1.A.4 Retail** Retail exposures are subject to a lower risk weight of

$$RW(\text{retail}) = 75\%.$$

Retail exposures are exposures to individual persons or small businesses. The concerned products are revolving credits, lines of credit (e.g., credit cards and overdrafts), personal term loans and leases (e.g., instalment loans and leases, student and educational loans, personal finance). The facilities in a retail portfolio need to be sufficiently granular, e.g., a counterpart's exposure in the retail portfolio may not exceed 0.2% of the total portfolio and may not exceed €1 million.

The risk weight of 75% is beneficial for small companies with respect to large companies. It stimulates the economic framework of small and medium-sized enterprises (SMEs). Local regulators can increase the risk weight when the local loss statistics indicate higher risk. A risk weight of 100% is applicable under Basel I [49].

Claims fully secured by mortgages or residential property that is or will be occupied by the borrower, or that is rented, will be risk weighted at

$$RW(\text{residential mortgage}) = 35\%.$$

The risk weight is only applicable for residential purposes and when the claim is sufficiently secured. When the local loss statistics indicate that a higher risk weight is required, local regulators may require banks to increase the risk weight accordingly in their jurisdiction. In the Basel I framework, a risk weight of 50% was assigned to these facilities.

Claims secured by commercial real estate receive a risk weight of 100%. The BCBS justifies the high risk weight because these exposures have been a recurring cause of troubled assets in the past few decades (see also Table 1.5). Well-defined exceptions<sup>80</sup> allow local supervisors to lower the risk weight to 50% in well-developed and long-established markets. In conclusion, one has

$$RW(\text{commercial mortgage}) = 50\% \quad \text{or} \quad 100\%.$$

In Basel I, the risk weight is equal to 100% as well, except for specific extinct cases where 50% is applicable [49]. Note that the risk weights for residential and commercial real estate allow physical collateral to be taken into account.

The above risk weights are applicable for all loans except for past due loans that receive a higher risk weight.

**6.3.1.1.A.5 Securitization** For securitization purposes, the risk weights are assigned towards long-term or short-term ratings. From Table 6.6 it is seen that the risk weight becomes very high for low-rated tranches. For the lowest ratings, a deduction from capital is required, where the general rule is to deduct 50% of the Tier 1 and 50% of the Tier 2 capital. For off-balance sheet exposures, a credit conversion factor is applied and the corresponding risk weight is applied.

<sup>80</sup> The exceptions concern loans that are sufficiently collateralized or portions of the loan with a sufficiently high loan-to-value in the well-developed countries in which losses have been sufficiently low historically: maximum 0.3% in any year for the highly collateralized portions and portfolios, and 0.5% in any given year on the full real estate lending portfolios.

**6.3.1.1.A.6 Past due loans and higher-risk categories** Specific weights are applicable under Basel II for loans past due more than 90 days. The unsecured portion of such loans, net of specific provisions, is weighted with

$$RW(\text{past due}) = 100\% \quad \text{or} \quad 150\%,$$

depending on the amount of specific provisions (above or below 20%), and the supervisory regulation [63]. In the case of qualifying residential mortgage loans, the risk weight is 100%.

The Basel II Capital Accord explicitly recognizes higher risk categories to which a higher risk weight is assigned: claims on sovereigns, public sector entities, banks and securities firms with a rating below B–; claims on firms rated below BB–; past due loans mentioned above. Securitization tranches rated between BB+ and BB– are risk weighted at 350%. National supervisors have the discretion to define higher risk weights for other assets like, e.g., venture capital and private equity investments.

**6.3.1.1.A.7 Other assets** The treatment of other assets is subject to a general risk weight of

$$RW(\text{other assets}) = 100\% \quad \text{or} \quad 150\%.$$

Investments in equity or regulatory capital instruments issued by banks or securities firms will be risk weighted at 100% unless deducted from capital.

**6.3.1.1.A.8 Unrated facilities** The risk weight for unrated counterparts/facilities reflects the average risk for that type of counterpart worldwide. It assumes that there is no systematic adverse selection that unrated counterparts are weaker. National supervisors sometimes increase the risk weight for unrated counterparts to put the risk weight in line with the local risk experience.

**6.3.1.1.A.9 Off-balance sheet items** Off-balance sheet items are converted to an equivalent credit exposure via the credit conversion factor (CCF):

$$\text{equivalent credit exposure} = \text{CCF} \times \text{off-balance sheet exposure}.$$

The following CCF values apply:

CCF = 0%: Commitments that are unconditionally, at all time and without prior notice cancellable or when the cancellation results from a deterioration of the borrower's creditworthiness.

CCF = 20%: Commitments with an original maturity up to one year; short-term self-liquidating trade letters arising from the movement of goods.

CCF = 50%: Commitments with an original maturity over one year (long-term commitments).

CCF = 100%: Lending of bank's securities or the posting of securities as collateral by banks.

For a commitment on an off-balance sheet item itself, the lowest of the two CCF values is applied. Consider for example an unconditionally cancellable commitment (CCF = 0%), for example on a commitment of a bank to a short-term trade letter (CCF = 20%): for this type of "double" commitment, one applies the lowest CCF of 0%. In the case of a long-term commitment on a long-term commitment, the CCF is equal to 50% and not equal to  $50\% \times 50\% = 25\%$  that would be obtained by multiplying the CCF values.

For failed trades, the existing regulation is harmonized in Annex 3 of [63]. Banks are encouraged to develop systems to track and monitor credit risk exposures arising from unsettled and failed transactions. One considers two types of products:

**Delivery-versus-payment:** For transactions settled through delivery-versus-payment (DvP) or payment-versus-payment (PvP) systems, the exposure is the difference between the agreed settlement price and the current market price, i.e. the positive current exposure. The capital charge is obtained by multiplying the positive current exposure by the capital multipliers of Table 6.7.

**Free-delivery:** For non-DvP or free-delivery transactions, where cash is paid without receipt of the corresponding receivable (securities, foreign currencies, gold, or commodities), the exposure amount is the full amount of cash paid or value-delivered deliverables. The risk weight depends on the payment or delivery delay:

1. If the other part (so-called second leg) of the transaction is not received at the end of the business day, the exposure is treated as a loan either in the standardized or IRB approach. If exposures are not material, a uniform risk weight of 100% may be applied.

**Table 6.7** Risk capital multiplier for net positive exposures of failed delivery-versus-payment transactions for increasing payment delay (number of working days after the agreed settlement date).

Payment delay	Risk multiplier
5–15	8%
16–30	50%
31–45	75%
≥46	100%

2. If the second leg is not received after 5 business days of the payment or delivery date, the exposure and possible replacement costs are deducted from capital.

The risk weight or deduction remain applicable until the actual delivery or payment.

### 6.3.1.1.B Implementation aspects (SA)

The use of ratings for capital charges implies various application issues. Many of these issues concern the practical interpretation and use of different ratings as explained in Chapter 3.

**6.3.1.1.B.1 Split ratings** In the case of multiple assessments, split ratings can occur. One uses the most conservative risk weight in the case of two external ratings. When there are more than two external ratings, one selects the highest of the two lowest risk weights. For example, a firm with ratings AA–, A, BBB+ and BBB, is assigned the risk weight 50% corresponding to the rating A (Table 6.6). Banks must disclose the used ECAIs and use all available ratings to avoid cherry-picking. These rules result in the moderately conservative risk weights in the case of split ratings.

**6.3.1.1.B.2 Mapping process** As discussed in Chapter 3, there exist multiple rating agencies in the world of which not all adopt the AAA, AA+, . . . rating scale. Supervisors need to determine the eligible ECAIs for the standardized approach. Furthermore, they also need to map their ratings to the corresponding risk weights, e.g., based upon past default and loss statistics.

**6.3.1.1.B.3 Local and foreign currency ratings** Foreign currency ratings are applied for foreign currency exposures. For local currency exposures, local currency ratings are applied. When the transfer risk is sufficiently mitigated, local currency ratings can also be applied to foreign currency exposures.

**6.3.1.1.B.4 Issue and issuer ratings** The risk weight is assigned based upon the issue-specific rating. It can occur that the bank invested in an unrated issue, while other issues or the issuer itself are rated. When the bank invested in a facility that is more senior or ranks *pari passu* with the rated issue, this rating can be used; otherwise the bank's issue is unrated. The issuer rating is considered to apply for senior unsecured claims, and can only be applied to assign risk weights to issues equally or higher rated. For senior secured exposures where the seniority is already taken into account in the issue rating, the risk mitigant cannot be taken into account twice. The improved rating cannot be used to apply a lower risk weight and at the same time apply a risk mitigant to further reduce this lower risk weight.

**6.3.1.1.B.5 Group and holding ratings** Ratings assigned to a group or to an entity cannot be applied to other entities within the same group, although this would reduce the number of unrated issues.

**6.3.1.1.B.6 Short-term ratings** Short-term issue ratings are applicable to banks and firm exposures. Short-term ratings A-1/P-1, A-2/P-2 and A-3/P-3 correspond to risk weights of 20%, 50% and 100%, respectively. The rules for short-term exposures are further detailed in [63].

**6.3.1.1.B.7 Unsolicited ratings** To avoid ECAIs putting pressure on issuers, banks should only use solicited ratings. When such unwanted behavior of an ECAI is identified, national supervisors should reconsider its eligibility.

### **6.3.1.1.C Risk mitigation (SA)**

Risk-mitigation techniques are taken explicitly and more profoundly into account in the Basel II rules to make the capital requirements more risk sensitive. In addition, the market for risk mitigation and credit derivatives has evolved a lot compared to 1988. The new framework allows

these recent risk management evolutions to be taken into account in the calculation of the risk weights. The resulting risk weight with the risk-mitigation effect is lower than without the risk-mitigation. An overview of risk-mitigation techniques and their treatment is given in the sections below.

**6.3.1.1.C.1 Collateralized transactions** In a collateralized transaction, the (potential) credit exposure is hedged in whole or in part by collateral posted by a counterpart or by a third party on behalf of the counterpart. The collateral is taken into account via the comprehensive approach or via the simple approach. Banks can choose either one of both approaches for the banking book. For the trading book, only the comprehensive approach can be applied.

Several conditions have to be satisfied to make the collateral eligible for risk weight reduction. For the simple approach, the eligible collateral types are specified in section 144 [63]. These collateral types are called financial collateral and are also eligible under the internal ratings based approach. Among others, one finds cash, deposits, gold, debt securities, equities included in a main index, Undertakings for Collective Investments in Transferable Securities (UCITS) and mutual funds. Debt securities are recognized when they have a sufficiently high rating from an ECAI (e.g., at least BB– for sovereign debt and BBB– for other entities), or when it is issued by a bank and information is available to indicate sufficient quality. For the comprehensive approach, listed equities and UCITS or mutual funds that include such equities are also eligible as collateral.

Legal requirements have to be satisfied to ensure that the bank has the right to liquidate or take legal possession of the pledged collateral in a timely manner after a default event. The collateral may not be correlated materially with the debt value in order to provide sufficient protection. For example, shares of the same counterpart do not provide protection in a default risk event. Collateral assets held by a custodian bank should be segregated from the custodian's own assets. The impact of collateral is calculated either via the comprehensive or the simple approach.

**Comprehensive approach** In the comprehensive approach, the haircut exposure is adjusted with the haircut collateral. The exposure after risk



mitigation for a collateralized transaction is calculated as follows:

$$\begin{aligned}
 E^* &= \max (0; E \times (1 + H_e) - C \times (1 - H_c - H_{fx})) \\
 &= \max (0; E - C + H_e \times E + C \times H_c + C \times H_{fx}). \quad (6.4)
 \end{aligned}$$

The above model can be considered as a white box model, as described in eqn 4.16. Haircuts take into account the uncertainty of the exposure ( $H_e$ ) and the uncertainty of the collateral value at liquidation. There are various reasons why the exposure and collateral value can fluctuate: exchange rate ( $H_{fx}$ ) and price market fluctuations ( $H_c$ ). The exposure haircut increases the current exposure  $E$  and the resulting net exposure  $E^*$  at which the risk weight is applied, the other two haircuts reduce the collateral value  $C$  and increase the net exposure  $E^*$ . When the collateral consists of a basket of assets, one calculates the amount-weighted average haircut of the asset haircuts and applies it to the basket.

Banks can either choose standardized supervisory haircuts or internal estimates of market-price volatility. The haircuts depend on the instrument type, the transaction type, etc. Table 6.8 provides some examples of standardized supervisory haircuts assuming a 10-business-day holding period. Debt securities with ratings lower than indicated in the table are assigned equity haircuts listed on a recognized exchange. The exchange rate haircut takes into account currency risk when exposure and collateral are denominated in

**Table 6.8** Examples of standardized supervisory collateral haircuts  $H_c$  assuming a 10-business day holding period and daily mark-to-market.

Collateral type	Res.Mat.	$H_c$	Res.Mat.	$H_c$	Res.Mat.	$H_c$
Cash in same currency				0%		
Sovereign debt AAA to AA-	$\leq 1y$	0.5%	$> 1y, \leq 5y$	2%	$> 5y$	4%
Sovereign debt A+ to BBB-	$\leq 1y$	1%	$> 1y, \leq 5y$	3%	$> 5y$	6%
Sovereign debt BB+ to BB-				15%		
Other debt AAA to AA-	$\leq 1y$	1%	$> 1y, \leq 5y$	4%	$> 5y$	8%
Other debt A+ to BBB-	$\leq 1y$	2%	$> 1y, \leq 5y$	6%	$> 5y$	12%
Main index equities				15%		
Other equities				25%		
Gold				15%		
UCITS				Highest haircut of security it can invest in		

different currencies. It is calibrated at

$$H_{fx} = 8\% \tag{6.5}$$

for a 10-day holding period and a daily mark-to-market.

When this is not applicable, a rescaling formula is applied:

$$H = H_M \sqrt{\frac{N_R + T_M - 1}{T_M}},$$

with  $H$  the resulting haircut,  $H_M$  the haircut under the minimum holding period,  $T_M$  the minimum holding period for the transaction type and  $N_R$  the actual number of business days between remargining<sup>81</sup> for capital market transactions or revaluation for secured transactions. When the regulatory haircuts are applied, one obtains  $H_M$  from Table 6.8 and  $T_M = 10$ .

Internal estimates are based upon a 99th percentile VaR that is estimated using at least one year of data history. For daily remargining or revaluation, the holding period ranges from 5 to 10 business days depending on the type of facility, and can be adjusted in the case of low liquidity. These resulting haircuts are scaled using the square root law (assuming Brownian motion) adjusting for longer holding periods or less frequent revaluations. When internal haircuts are applied, one needs to update at least every 3 months the datasets and evaluate the resulting haircuts. The VaR haircuts are evaluated using a variety of techniques available for market risk [10, 78, 95, 260, 426]. In the latter case, eqn 6.4 becomes

$$E^* = \max \left( 0; \sum E - \sum C + \text{VaR}(0.99) \times \text{multiplier} \right).$$

When these estimates exhibit too many exceptions, a penalization scaling factor ranging from 1 to 1.33 is applied similar to the internal market risk approach explained below in section 6.3.2.4. For netting  $E^*$  becomes

$$E^* = \max \left( 0; \sum E - \sum C + \sum |E_s| \times H_s + \sum |E_{fx}| \times H_{fx} \right), \tag{6.6}$$

<sup>81</sup> A margin account is a brokerage account in which the broker lends money to the customer to purchase equities and securities. The loan is collateralized by cash of the customer or equities, e.g., the invested equities. The margin account allows the customer to leverage its investments, magnifying gains and losses. The leverage is monitored at regular dates to avoid unacceptable high leverages that may result in losses for the broker. When the collateral loses value, additional collateral can be required. Remargining is putting additional cash or securities to correct a deficiency in equity in the margin account. A margin call typically prompts the remargining.

with  $|E_s|$  the absolute value of the net position in a given security and  $|E_{fx}|$  the absolute value of the net position in a currency different from the settlement currency. Details for repo-style transactions are also provided in [63]. It is also important to remark that under certain circumstances, a zero haircut can be applied.

**Simple approach** In the simple approach, the risk weight of the counterparty is substituted by the risk weight of the collateral (subject to a 20% floor) for the collateralized portion of the exposure, similar as in the Basel I accord [49]. The collateral must be pledged at least for the life of the exposure and has to be marked to market and revaluated with a minimum frequency of 6 months [63]. The risk weight floor of 20% can sometimes be reduced to 10% and 0%.

**Collateralized OTC derivatives transactions** The counterparty credit risk charge for this type of products is calculated by either the current exposure method, the standardized method or the internal model method. The latter two are more complex approaches and will be discussed below. Using the current exposure method, the capital requirements is obtained as:

$$\begin{aligned} \text{capital} &= \text{EAD} \times \text{RW} \times 8\% \\ \text{EAD} &= (\text{RC} + \text{add-on}) - C_A, \end{aligned}$$

with  $\text{RC} \geq 0$  the positive replacement cost or current exposure (see section 4.4.3.3),  $C_A$  the haircut collateral amount, RW the counterparty's risk weight. The add-on

$$\text{add-on}_i = f_i \times \text{notional amount}_i \quad (6.7)$$

is obtained as the transaction notional times the add-on factor  $f$  reported in Table 6.9. For an OTC contract on gold with notional of €1000 with a current market value of €40 and remaining maturity of 20 months, the EAD is calculated as

$$\text{EAD} = 40 + 5.0\% \times 1000 = 90.$$

If the counterparty is an externally rated bank with an A+ rating, the risk weight is 50% (Table 6.6) and the risk weighted assets for this transaction are €45 ( $= 50\% \times €90$ ). Also, for the total return swaps and credit default swaps in the trading book, this methodology is applicable with add-on factors

**Table 6.9** Add-on factors  $f$  for the notional amount of various instrument types to calculate the exposure risk in OTC derivatives transactions.

Instrument \ $f$	$M \leq 1y$	$1 < M \leq 5$	$5 < M$
Interest rates	0.0%	0.5%	1.5%
FX and gold	1.0%	5.0%	7.5%
Equities	6.0%	8.0%	10.0%
Precious metals	7.0%	7.0%	8.0%
Other	10.0%	12.0%	15.0%

**Table 6.10** EAD calculation (eqn 6.8) with the standard method and netting agreements. The notional amounts (€) of the 4 contracts are reported in the second column. The add-on factor and add-on amounts from eqn 6.7 are reported in columns 3 and 4, respectively. The market value and replacement costs are reported in columns 5 and 6, respectively. The total add-on amount equals €170. The net market value or replacement cost is €50 and the gross replacement cost is €150, such that the NGR equals  $0.33 = 50/150$ . The resulting add-on after netting from eqn 6.8 equals €102 and the EAD equals €152 = €50 + €102.

$i$	Notional <sub><math>i</math></sub>	Add-on factor $f_i$	Add-on amount <sub><math>i</math></sub>	Market value <sub><math>i</math></sub>	Replacement cost <sub><math>i</math></sub>
1	1000	5.00%	50	100	100
2	1500	1.00%	15	50	50
3	2000	1.50%	30	-60	0
4	1250	6.00%	75	-40	0
	<b>Total</b>		<b>170</b>	<b>50</b>	<b>150</b>

equal to 5% or 10%. The 5% is applicable when the underlying is a qualifying reference obligation<sup>82</sup> otherwise the 10% add-on factor is applied. In the case of legally enforceable netting agreements, the replacement cost is the net replacement cost (floored at zero) corrected by collateral with haircut adjustments. The portfolio add-on is calculated as

$$\text{add-on} = (0.4 + 0.6\text{NGR}) \sum_i \text{add-on}_i, \tag{6.8}$$

where the NGR is the ratio of the current net replacement cost with respect to the current gross replacement cost (without netting). Via the NGR, the current netting benefits are passed to future exposure risk. The method is illustrated in Table 6.10.

<sup>82</sup> Qualifying reference obligations are securities issued by public-sector entities and multilateral development banks, investment grade rated by external rating agencies or stocklisted and internally rated investment grade as specified in section 711 of [63].

**6.3.1.1.C.2 On-balance sheet netting** Banks may have loans and deposits of the same counterpart. When the bank has legally enforceable netting arrangements in the concerned jurisdictions, the bank may calculate the capital requirement for the net exposure. The legal framework should hold in the case of default and bankruptcy procedures. It is also important that the bank has sufficient monitoring and controls. In the case of currency mismatches, one applies haircuts as in the case of collateral following the same approach. The corresponding formula (eqn 6.6) resembles the formula for collateral (eqn 6.4).

**6.3.1.1.C.3 Guarantees and credit derivatives** Guarantees and credit derivatives provide protection against credit losses. When there are legal requirements fulfilled such that the protection is direct, explicit, irrevocable and unconditional, and when supervisors are satisfied with the banks operational conditions, such risk mitigants may be taken into account for the capital requirements. Additional requirements concern explicit documentation of the guarantee and the timing and conditions when the bank can pursue the guarantor.

Because credit derivatives are complex products, there are many additional requirements concerning the definition of the credit event, identity of protection sellers, mismatches of maturity (including grace periods) and the underlying obligation of the credit derivative and the reference obligation in the bank's portfolio.

The range of eligible guarantors or protection sellers includes sovereigns, public-sector entities, banks and securities firms that have a lower risk weight than the counterpart for whom protection is given. Other entities are also required to have a rating higher or equal to A-. A good-rated parent company can give guarantees to weaker subsidiaries. The risk weight of the protected part becomes the risk weight of the guarantor or protection seller. The uncovered portion is weighted based upon the underlying counterpart. Haircuts are applicable in the case of currency mismatches.

**6.3.1.1.C.4 Maturity mismatches** A maturity mismatch exists when the residual maturity of the risk mitigant or hedge is less than the maturity of the underlying exposure (including grace periods). A hedge with maturity is only recognized as a credit risk mitigant when the original maturity is at least one year. In the case of a maturity mismatch, one applies the following

formula (section 205 [63]):

$$P_a = P \frac{t - 0.25}{T - 0.25}, \quad (6.9)$$

where  $P_a$  is the adjusted value of the protection for the maturity mismatch;  $P$  is the value of the credit protection;  $t$  is the minimum of the  $T$  and the remaining maturity of the credit protection and where  $T$  is the remaining maturity of the exposure capped at 5 years. Maturity is also capped at 5 years in the internal ratings based approach; which will be discussed after the examples in the next section.

**6.3.1.1.C.5 Examples** We illustrate the exchange rate risk haircut (eqn 6.5) and the collateral haircuts from Table 6.8 by some examples

1. Consider an exposure of €100 that is backed by a collateral of €60 of AA long-term debt with a remaining maturity of 8 years. The net exposure is equal to

$$E^* = 100 - 60 \times (100\% - 8\%) = 44.8,$$

where the 8% haircut for long-term other debt with AAA–AA rating is applied. In the case of a sovereign security, the haircut is equal to 4% and the net exposure would be equal to 42.4.

2. Consider an exposure of €100 that is backed by a collateral of US\$50 of A-rated medium-term debt with a remaining maturity of 4 years. The net exposure is equal to

$$E^* = 100 - 50 \times (100\% - 6\% - 8\%) = 57.$$

The 6% haircut takes into account the risk of the collateral, the 8% haircut takes into account the exchange rate risk. In the case of a 20-day holding period, the 6% haircut is multiplied by  $\sqrt{20/10}$  and becomes 8.5% and the net exposure 58.2. When the revaluation is done weekly instead of daily, one multiplies by  $\sqrt{24/10}$ , taking 10 + 4 additional days in the numerator for the 10 more days in the holding period and the 4 more days for the revaluation.

3. Consider an exposure of €1000 subject to a risk weight of 100% with a remaining maturity of 3.5 years. The full exposure is guaranteed by an entity with 20% risk weight for the first 2 years. The maturity mismatch

results in the adjusted protection

$$P_a = 1000 \frac{2 - 0.25}{3 - 0.25} = 538.5.$$

The not protected part is equal to  $1000 - 538.5 = 461.5$ . The resulting risk weighted assets are equal to

$$RWA = 538.5 \times 20\% + 461.5 \times 100\% = 569.2.$$

In the case of no maturity mismatch, the risk weighted assets would be equal to 200.

### 6.3.1.2 Internal ratings-based approach (IRBA)

In the internal-ratings-based approach (IRBA), the risk weighted assets (RWA) are for most asset classes obtained as a function of the risk components:<sup>83</sup>

$$RWA = f(\text{PD}, \text{LGD}, \text{EAD}, \text{M}). \quad (6.10)$$

The function  $f$  has been specified by the BCBS and may vary across different asset classes. For some specific, high-risk assets, lookup tables with risk weights are still applied.

Specific to the internal-ratings-based approach is that the risk weights and regulatory capital requirements are (partially) calculated based upon the bank's internal measurements of the risk components. The internal measurements need to comply with regulatory standards. Internal estimates of the credit risk parameters for default risk, loss risk, exposure and maturity are allowed depending on the chosen approach:

**IRBAf:** In the foundation internal-rating-based approach (IRBAf), the internal estimate for the probability of default (PD) is used to calculate the capital charge, while the other parameters are supplied by the regulator.

**IRBAa:** In the advanced internal-ratings-based approach (IRBAa), banks are allowed to provide internal estimates for LGD, EAD and maturity. Because the Basel II risk weight formulae do not use an asymptotic single risk factor model for the LGD, the LGD entered in the risk weight formula is a stressed default-weighted LGD, averaged over all defaults.

<sup>83</sup> In order to simplify notation, one uses LGD and EAD in the remainder of this chapter instead of  $\overline{\text{LGD}}^*$ ,  $\overline{\text{EAD}}^*$  defined in the previous chapter.

An overview of which risk parameters are set by the regulator or by the bank is given in Table 6.4.

Given the setup of eqn 6.10, it is easily understood that the IRBA methodology depends upon three key factors:

**Risk weight functions:** The risk weights and risk weighted assets (eqn 6.10) are computed<sup>84</sup> from risk weight functions explained in eqns 5.41–5.46.

**Risk components:** The risk components used in these risk weight functions (PD, LGD, EAD,  $\rho$ , M) are internal risk parameter estimates of which some are supervisory estimates. The estimation of the risk components has been reviewed in Chapters 2–4 and is explained in detail in book II. The asset correlation parameter  $\rho$  is set by the regulator.

**Minimum requirements:** The risk weight functions and internal risk parameter estimates can be used on condition that banks comply with minimum standards such as the Basel II default definition explained in section 4.4.1.1

These key factors are defined in the Basel II Capital Accord for each of the different asset classes of Table 6.5.

The overview of the foundation and advanced approach is organized as follows. The different asset classes considered in IRBA are discussed in section 6.3.1.2.A. The risk weight functions, risk components and risk measurement requirements may vary across different asset classes and between the foundation and advanced approach. An overview of the key factor is given for each of the asset classes in section 6.3.1.2.B. Additional general requirements are summarized in section 6.3.1.2.C.

### 6.3.1.2.A Categorization of exposures into asset classes (IRBA)

There are 5 regulatory asset classes<sup>85</sup> defined by section 215 [63]: firm, sovereign, banks, retail and equity. The firm class has 5 specific sub-classes for specialized lending. The retail class consists of 3 sub-classes. The overview of the different asset classes is available from Table 6.5.

<sup>84</sup> Note that the Basel II framework is a general framework that will continue to be reviewed in the future. Resulting from the Madrid compromise, the expected loss was dropped from the capital requirement. As a result, from the quantitative impact studies, the BCBS proposed to scale IRB risk weights with the scaling factor 1.06 (section 14 in [63]) to maintain current capital levels in banks. Local regulation may impose other risk scaling factors. The European Capital Requirement Directive (CRD) also imposes a multiplication factor of 1.06.

<sup>85</sup> The securitization exposures are described separately in the Basel II Capital Accord [63]. In this summary, securitization exposures are discussed together with the 5 asset classes for reasons of conciseness.



**6.3.1.2.A.1 Firm exposures** A firm exposure is defined as a debt obligation of a corporation, partnership or proprietorship. Small and medium-size firms are assigned an up to 4% lower correlation than large firms, as can be seen from eqn 5.42. The firm asset class also includes insurance companies.

The firm asset class also contains 5 firm asset classes that are defined specifically for specialized lending transactions. In specialized lending, the exposure is typically a special purpose entity that was created specifically to finance or operate financial assets and where it has little or no other material assets or activities. The primary source of income for repayment is generated by the assets of the special purpose entity rather than a broader commercial organization. In most situations, the bank is a close partner of the specialized lending transaction and has a substantial control on the assets and the generated income. The 5 subclasses for specialized lending are:

**Project finance (PF):** The revenues are typically generated by a single large and complex project, e.g., power plants, chemical plants, mines, tunnels, bridges, or other infrastructure projects and telecommunications infrastructure.

**Object finance (OF):** The transaction has the aim to acquire a large physical asset, e.g., ships, aircrafts, satellites. The repayment of the claims depends on the cash flow generated by the object.

**Commodities finance (CF):** Structured short-term lending to finance reserves, inventories or receivables of exchange-traded commodities like crude oil, metals or crops. The debt is repaid by the proceeds of the sale of the commodities.

**Income-producing real estate (IPRE):** The debt is used to fund real estate like office buildings to let, retail space, multifamily residential buildings, industrial or warehouse space, or hotels. The primary source of cash flows to repay the debt are lease payments, rental payments or the sale of the real estate asset.

**High-volatility commercial real estate (HVCRE):** The financing of some real estate types is more risky than IPRE transactions. Such transactions are categorized by the national supervisors based upon the volatility and correlation of past loss history and may include land acquisition, development and construction, as well as transactions where the source of the cash flows is sufficiently uncertain.

**6.3.1.2.A.2 Sovereign exposures** This asset class covers all the exposures defined as sovereigns in the standardized approach (section 6.3.1.1).

It also includes national banks, certain multilateral development banks, international organizations, as well as some types of public-sector entities.

**6.3.1.2.A.3 Bank exposures** As in the standardized approach, the bank asset class covers banks and certain securities firms that are subject to regulation. It also contains multilateral development banks and public-sector entities that are not categorized as sovereigns.

**6.3.1.2.A.4 Retail exposures** An exposure is a retail exposure when it meets a long list of criteria defined in section 231 [63]. These criteria concern the nature of the borrower or the low value of the individual exposures and the large number of exposures. Exposures to individuals like revolving credits and lines of credits (credit cards, overdraft, . . .) and personal term loans and leases (car loans, student loans, . . .) are generally considered as retail loans. The same holds for residential mortgage loans when these are granted to the individual owner-occupier of the property. Small business loans are considered as retail loans when the total (consolidated) exposure is less than €1 million. Larger exposures are treated as firms. Each exposure must belong to a large pool of exposures and must be treated consistently on a pooled basis and not as a firm by the bank's risk management.

The retail asset class is partitioned into 3 subclasses:

**Qualifying revolving retail exposures (QRRE):** It concerns revolving, unsecured and uncommitted exposures that are held by individuals that are permitted to borrow up to a limit set by the bank (max €100,000). Within this limit, customers are allowed to borrow and repay at their discretion. Because this portfolio is assigned a low asset correlation (eqn 5.44), the low loss volatility has to be justified by past loss experience.

**Residential mortgages:** Residential mortgages provide funding for the purchase of residential real estate that is purchased by an individual with the purpose to occupy the property.

**Other retail exposures:** This category contains all retail exposures that belong neither to qualifying revolving retail exposures nor to residential mortgages.

Note that purchased receivables are categorized either into retail or firm exposures. Specific rules apply for these assets and are applicable to reduce regulatory burden.

**6.3.1.2.A.5 Equity exposures** An equity exposure is defined based upon the economic substance of the investment instrument, which typically includes direct ownership interests with or without voting power. Equity exposures are irredeemable, the invested funds are returned only in the case of a sale or liquidation. They do not embody an obligation to the issuer and convey a residual claim on the assets or income of the issuer. Also, Tier 1 capital instruments and some specific obligations like perpetual obligations and obligations that can be settled in equity shares, are also considered as equity.

**6.3.1.2.A.6 Securitization exposures** There are many types of securitization exposures like investments in asset-backed securities (ABSs) and collateralized debt obligations (CDOs). Exposures may also result from risk mitigants on these exposures, retention of a subordinated tranche and extension of a liquidity facility or credit enhancement. Securitization exposures are described separately from the 5 asset classes described above.

### **6.3.1.2.B Risk components and risk weights (IRBA)**

The risk components and risk weights are defined for the different asset classes.

**6.3.1.2.B.1 Corporate, sovereign and bank exposures** In the foundation approach (IRBAf), the bank's internal estimates for PD are used together with supervisory settings for LGD, EAD and M. Under the advanced approach (IRBAa) the bank's internal estimates for PD,  $\overline{\text{LGD}}^*$ ,  $\overline{\text{EAD}}^*$  and the internal effective maturity M is calculated. In order to simplify notation, LGD and EAD are used instead of  $\overline{\text{LGD}}^*$ ,  $\overline{\text{EAD}}^*$  in the remainder of this chapter.

The firm risk weight function is given by eqn 5.41 with maturity adjustment (eqn 5.46) and correlation function (eqn 5.42). The same risk weight function is applicable for the sovereign and bank asset classes. Note that small and medium-size firms have a beneficial risk weighting due to a lower correlation up to 4%.

An exception to these rules are the 5 specialized lending subclasses. When the minimum requirements are not met for the estimation of the PD (e.g., because the bank has insufficient data history), the banks can use the supervisory slotting criteria approach that maps the specialized lending assets into 5 supervisory categories ranging from low to high risk. Table 6.11 gives an overview of the expected loss (EL) and unexpected loss (UL) risk weights

**Table 6.11** Supervisory categories, corresponding rating grades, expected loss (EL) and unexpected loss (UL) risk weights for specialized lending exposures with the slotting approach. The expected loss is obtained as 8% of the EL risk weight.

Supervisory Cat. Eq. Rating	Strong AAA to BBB-	Good BB+ or BB	Satisfactory BB- or B+	Weak B and below	Default D
PF, OF, CF, IPRE: EL	5%	10%	35%	100%	625%
PF, OF, CF, IPRE: UL	70%	90%	115%	250%	0%
HVCRE: EL	5%	5%	35%	100%	625%
HVCRE: UL	95%	120%	140%	250%	0%

applicable. Higher risk weights are applicable for the high-risk HVCRE segment. For this asset class, the foundation and advanced IRBA methods are applicable only under strict national regulatory approval, and when a special correlation function is applied in the risk weight function that interpolates between 12% and 30% (see section 283 [63]). National supervisors are allowed to adjust some of the risk weights in Table 6.11 within defined ranges.

**Probability of default (PD)** The PD for firm, bank and sovereign exposures is not lower than the 5-year averaged one-year default rate. The concerned default rate is the observation weighted default rate. For firm and bank exposures, a floor of 0.03% is applicable. The PD of the default grades is equal to 100%.

The PD measures the risk of the borrower default. Separate exposures to the same borrower must be assigned the same<sup>86</sup> borrower default risk grade. The PD estimate must be a long-term average of one-year default rates for the specific grade as illustrated in Fig. 3.2. The options to estimate the default risk are the estimation based upon internal default experience, the mapping to external data, and statistical default models. The latter are discussed in book II. One method can be used as the main approach and another can be used for benchmarking. The minimum data history needs to be at least 5 years for one data source. The use of longer data histories is recommended where possible. The lower the number of observations, the

<sup>86</sup> There are two exceptions. Local and foreign currency positions can be assigned to different borrower grades. When some facilities are guaranteed, the reduced risk can be reflected in a different risk grade.

higher is the uncertainty on the PD estimate and the more conservative the calibration must be.

**Loss given default (LGD)** The LGD reflects transaction-specific factors such as collateral, seniority, product type, etc. In the foundation IRB approach, one can assign transaction-specific risk implicitly via an expected loss dimension or via an LGD dimension. In the advanced IRB approach the LGD dimension is the only option.

*Foundation IRBA* In the foundation IRB approach, the supervisory LGD estimates must be used. The LGD of unsecured and subordinated exposures are equal to

$$\text{LGD}_{\text{unsecured}} = 45\% \quad \text{LGD}_{\text{subordinated}} = 75\%, \quad (6.11)$$

respectively. Applying the default rates of Fig. 3.1 and the unsecured LGD of 45%, one obtains the risk weights for unsecured exposures to large firms reported in Fig. 6.4. Observe that for the lowest-risk counterparts, the foundation IRBA risk weights are lower than the standardized risk weights. For very low ratings, the foundation IRBA risk weights are higher.

For secured exposures, one applies the formula

$$\text{LGD}^* = \text{LGD} \times \frac{E^*}{E}, \quad (6.12)$$

where the net exposure is calculated as in the standardized approach (eqn 6.4)–(eqn 6.6). The eligible collateral consists of the financial collateral<sup>87</sup> (from the standardized approach, Table 6.8) and of the eligible IRBA collateral. The eligible IRBA collateral includes receivables, specified commercial real estate (CRE) and residential real estate (RRE) and others. These collateral types are subject to requirements (section 506–522 [63]). For eligible financial receivables, the requirements concern a maximum maturity of one year, legal certainty and risk management processes. For CRE and RRE collateral, the requirements concern independence of the obligor's risk, legal enforceability, objective market value, frequent revaluation and corrections for non-first charge on collateral (e.g., when personnel wages have higher priority by law). Local supervisors may recognize other eligible physical

<sup>87</sup> The simple approach is not applicable for IRBA banks.

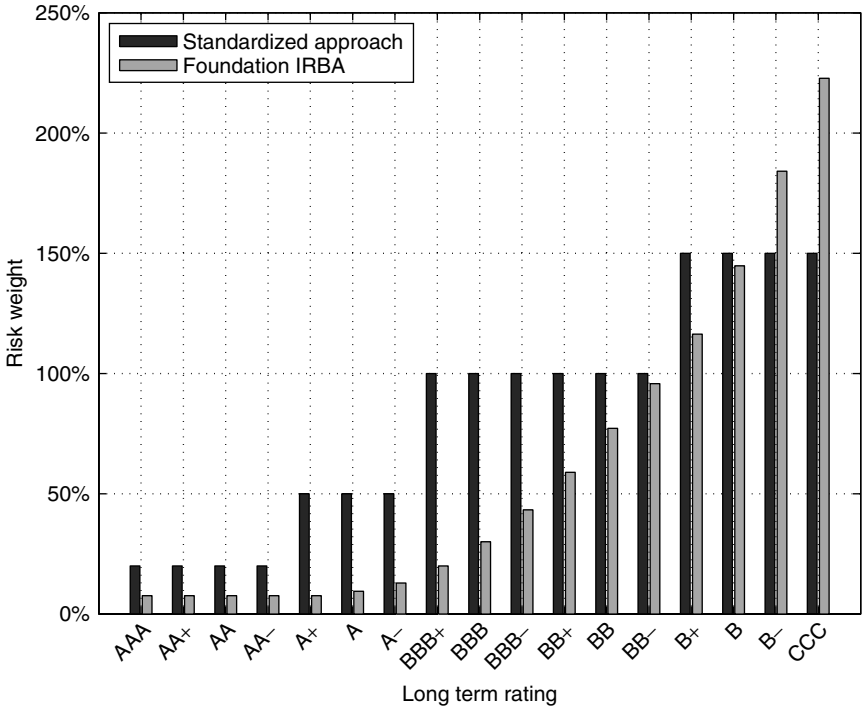

**Fig. 6.4** Risk weights for firms under the standardized approach and the foundation internal-ratings-based approach for senior unsecured exposures (LGD = 45%) [63]. The idealized default rates of Fig. 3.1 are applied subject to a floor of 0.03%.

collateral types when there are sufficiently liquid markets to dispose collateral and when there exist publicly available market prices. Additional requirements include the first claim property, loan agreement specifications, collateral revaluation, etc.

For the eligible IRBA collateral, the LGD is calculated from the following formula:

$$\text{LGD}^* = \begin{cases} \text{LGD} & \text{if } C < C^* \\ \text{LGD}_C |C/C^{**}|_0^1 + \text{LGD}(1 - |C/C^{**}|_0^1) & \text{if } C^* < C < C^{**} \\ \text{LGD}_C & \text{if } C^{**} < C. \end{cases} \tag{6.13}$$

If the collateral  $C$  (proportional to the exposure) is below the minimum threshold level  $C^*$  then the collateral is not taken into account. Above the maximum threshold level  $C^{**}$  the collateral is fully taken into account and the minimum  $\text{LGD}_C$  is applicable. For intermediate values, the covered part

**Table 6.12** Minimum  $LGD_C$  for the secured portion of senior exposures [63]. The resulting LGD for the secured exposure is obtained from eqn 6.13.

Type	$LGD_C$	$C^*$	$C^{**}$
Eligible Financial Collateral	0%	0%	N.A.
Receivables CRE	35%	0%	125%
RRE	35%	30%	140%
Other Collateral	40%	30%	140%

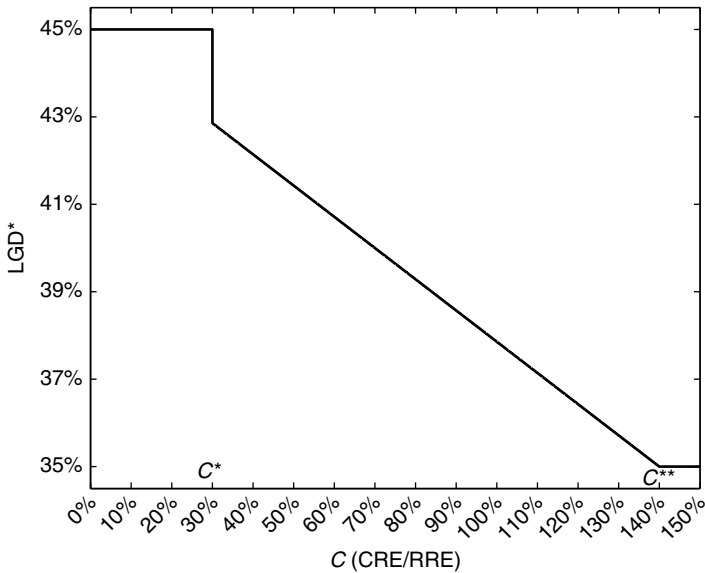

**Fig. 6.5** Evolution of the firm LGD from unsecured LGD ( $LGD = 45\%$ ) to a fully collateralized LGD ( $LGD_C = 35\%$ ) as a function of the coverage  $C$  with CRE/RRE collateral. The collateral is eligible when the coverage exceeds  $C^* = 30\%$ . It is considered as fully collateralized when the coverage exceeds  $C^{**} = 140\%$ .

$C/C^{**}$  is subject to the minimum LGD, the remaining part is subject to the unsecured LGD (45% for large firms from eqn 6.11). The parameters for the different exposure types are summarized in Table 6.12 and are illustrated for CRE/RRE collateral in Fig. 6.5. Note that the 0% values for the eligible financial collateral are coherent with the standardized approach, where there

is also no minimum coverage required. In the case of multiple collateral types, one applies eqn 6.13 to the different types. If the ratio of the sum of the values of the CRE/RRE and other collateral to the reduced exposure (after financial collateral) is below  $C^*$ , this part is assigned the unsecured LGD. The approach is illustrated by some examples:

1. Consider a loan of €500,000 that is secured by a CRE collateral ( $C^* = 30\%$ ,  $C^{**} = 140\%$ ) with value equal to €600,000. The proportional collateral value is equal to  $C = 120\%$ , which indicates that there is no full coverage. From Table 6.12, the coverage is equal to  $120\%/140\% = 85.7\%$ . The unsecured part is equal to 14.3%. The resulting  $LGD^*$  is equal to

$$LGD^* = 45\% \times 14.3\% + 35\% \times 85.7\% = 43.6\%,$$

where the unsecured LGD is obtained from eqn 6.11. If the collateral value were lower than €150,000, the proportional collateral becomes lower than 30% and it will not be recognized.

2. Consider a loan of €500,000 that is secured by €100,000 of AA bonds with maturity of 4 years and by a CRE of €400,000. There is no maturity mismatch between the loan and the financial collateral. The net coverage provided by the AA bonds is equal to  $€100,000 \times (100\% - 4\%) = €96,000$  or 19.2% of the exposure. (Table 6.8). The resulting net exposure is  $€500,000 - €96,000 = €404,000$ . The CRE provides a net coverage of  $400,000/140\% = 285,174$  or 57.1% of the total exposure (Table 6.12). The unsecured part is equal to  $100\% - 19.2\% - 57.1\% = 23.7\%$ . The resulting  $LGD^*$  is equal to

$$LGD^* = 19.2\% \times 0\% + 57.1\% \times 35\% + 23.7\% \times 45\% = 31\%.$$

Although the €500,000 loan is collateralized by a pool of €500,000, the LGD drops only from 45% to 31%.

Guarantees and credit derivatives are treated in the foundation approach in a similar way as in the standardized approach, except that the range of companies that is rated internally as A– or better is also eligible as guarantors. The guarantees are taken into account by substituting (partially) the risk weight, the PD and/or the LGD or applying the double-default framework discussed below.

*Advanced IRBA* In the advanced approach, banks are completely free to measure the LGD and determine the impact of risk mitigants. The period to



estimate the average LGD needs to cover at least one full economic cycle. The minimum time horizon is 7 years for at least one source. The lower the number of observations, the higher the level of conservativeness the bank should apply in its estimate.

As explained in Chapter 4, the LGD is a continuous variable that is analyzed by regression analysis, as will be further detailed in book II. Backtest procedures are provided in book III.

In the advanced approach, there are more options to take into account guarantees and credit derivatives. There are no explicit limits in the range of eligible guarantors. Compared to the foundation approach, the bank also provides internal LGD estimates. An important limitation is that the double-default effect cannot be taken into account. In the case of a guaranteed exposure, there is a loss for the bank in the case of a double default of both the borrower and the guarantor, which should be reflected in the risk weight:

1. If both default independently, the risk is reduced significantly, justifying a much lower risk weight.
2. When the default risk of the borrower and guarantor is not independent, the risk reduction can become far less.

In the Basel II Capital Accord, a conservative approach is taken:

**Substitution formula:** Two risk weights are calculated: the risk weight of the obligor exposure and the risk weight by substituting the PD and LGD of the obligor with the PD and LGD of the corresponding guarantor exposure. The lowest of both risk weights is taken.

**Double-default formula:** The double-default formula (eqn 5.49) is discussed in the previous chapter and recognizes that the risk weight is lower for good-rated guarantees. It assumes that both guarantor and obligor are dependent on systematic risk and have an additional dependence. For well-rated guarantors, the double-default formula recognizes the much lower risk compared to the substitution approach.

The substitution formula being the general approach, the double-default framework is applicable subject to specific eligibility criteria. Banks can use this option using single-name guarantees, single-name credit derivatives, first-to-default basket products and  $n$ th-to-default basket products. The double-default framework requires that the protection is sold by a bank, investment firm or financial insurance company of sufficient quality, i.e. it is subject to a Basel II equivalent regulation, has an investment grade

internal/external rating and has a rating equal to A– or above when the protection was first provided. A guarantor with initial rating A at the time of default is recognized and continues to be recognized in the case of downgrade to A–, BBB+, BBB or BBB– to avoid discontinuities in capital requirements. With a further downgrade to BB+, the double-default framework is no longer applicable. The underlying obligation is a firm exposure, a public sector entity or a loan to a small business or a retail exposure. The obligor should not be a financial firm or a member of the same group as the protection provider.

**Exposure at default (EAD)** The exposures are measured gross of specific provisions or partial write-offs. The EAD on a drawn amount should not be less than the amount by which the bank’s regulatory capital would be reduced if the exposure were written off fully and any specific provisions and partial write-offs. On-balance sheet netting is allowed under the same conditions as in the standardized approach. The undrawn amount is taken into account via a credit conversion factor (CCF).

*Foundation IRBA* The rules in the foundation IRBA approach are the same as for the standardized approach reviewed in section 6.3.1.1.A.9. These rules are applicable to the same products, except for commitments, note issuance facilities (NIFs) and revolving underwriting facilities (RUFs). To the latter, a CCF of 75% is applicable, except when these are uncommitted and unconditionally cancellable or have similar features.

The “undrawn exposure” to which the CCF is applied is the lower of the unused committed credit line and a value reflecting the impact of possible constraints on the facility (e.g., (semi-) automated ceilings on the lending amount that depend on the borrowers features). For unconditionally and immediately cancellable firm credit overdrafts and other facilities, a 0% CCF may be applicable if this low CCF is motivated by the bank’s risk management, monitoring and practices.

*Advanced IRBA* The bank is allowed to estimate its own EAD and/or CCF values as long as the CCF is not equal to 100% in the foundation approach. This estimation is subject to minimum requirements. The EAD is estimated on a time period that covers ideally a complete economic cycle. The minimum observation period must in any case be not shorter than 7 years for at least one data source. The calibrated EAD average is a default-weighted

average. It is not a time-weighted average. The default-weighted average puts higher weight on downturn periods that exhibit a high number of defaults.

As explained in Chapter 4 the EAD/CCF is a continuous variable for which the modelling and backtesting will be discussed in books II and III, respectively.

*Counterparty credit risk exposure:* The concept of exposure risk within the framework of counterparty credit risk has been discussed in section 4.4.3.3. Annex 4 of [63] mentions 3 possible approaches to determine the exposure equivalent:

*Current exposure method:* this simple method from the Basel I Accord has already been explained in section 6.3.1.1.C.1, it is only applicable for OTC derivatives.

*Standardized method:* the standardized method calculates the EAD based upon the exposure at default:

$$\text{EAD} = \beta \cdot \max \left( \sum_i \text{CMV}_i - \sum_k \text{CMC}_k; \sum_j \text{CCF}_j \left| \sum_i \text{RPT}_{ij} - \text{RPC}_{kj} \right| \right),$$

with

$\text{CMV}_i$ : current market value of the portfolio of contracts within the netting set (collateral not taken into account),

$\text{CMC}_k$ : current market value of collateral assigned to the portfolio, collateral received from the counterparty has a positive sign, pledged collateral has a negative sign,

$\text{RPT}_{ij}$ : risk position from transaction or contract  $i$  in the hedging set  $j$ ,

$\text{RPC}_{kj}$ : risk position from collateral  $k$  in the hedging set  $j$ ,

$\text{CCF}_j$ : supervisory credit conversion factor for the hedging set  $j$ .

The indices  $i$ ,  $j$  and  $k$  denote transactions, netting sets and collateral, respectively. Risk positions are expressed in the delta equivalent<sup>88</sup> value. The factor  $\beta$  is a supervisory scaling factor that is set to 1.4. The net exposures are grouped by hedging sets with index  $j$ . A hedging set is a subset of the netting set that represents contracts that are driven by

<sup>88</sup> For all but debt instruments, the effective notional value or delta equivalent notional value is  $p_{\text{ref}} \partial v / \partial p$  with  $p_{\text{ref}}$  the price of the underlying instrument in reference currency,  $v$  the value of the instrument or option and  $p$  the price of the underlying instrument in the same currency as  $v$ . For debt instruments, one multiplies the delta equivalent in notional value by the modified duration.

**Table 6.13** CCF values applied to the notional equivalent amount in the standardized method for counterparty credit risk exposure measurement.

FX and non-debt instruments		Debt instruments	
Type	CCF	Type	CCF
FX	2.5%	High specific risk	0.6%
Equity	7.0%	Credit default swap	0.3%
Gold	5.0%	Low specific risk	0.3%
Precious metals	8.5%	Other debt	0.2%
Other commodities	10.0%	Other OTC	10.0%
Electric power	4.0%		

the same risk factors, such that movements on risk factors cancel out. Because there exist many risk drivers of financial products, sufficient hedging sets are defined to ensure that the risk is correctly measured. Note that correlations of risk-driver evolutions between different product types in different hedging sets are not taken into account, cross-product netting is only possible in the internal models method.

For interest rate risk with low specific risk (capital charge less than 1.6 percentage points), one has 6 hedging sets per represented currency that differentiate amongst the nature of the reference contract rate (sovereign, non-sovereign) and the remaining maturity ( $M \leq 1$ ,  $1 < M \leq 5$ ,  $5 < M$ ). For high specific risk debt instruments, a hedging set is created for each issuer. For non-financial underlying instruments, one creates a hedging set for similar types (gold; precious metals: platinum, silver, palladium, metal index, . . .; equities: same issuer and indices, . . .; commodities: oil, steel, agricultural product types, . . .; electric power: (peak) loads within the same 24-hour interval). Indices are always considered as a separate hedging set. The corresponding credit conversion factors are reported in Table 6.13.

The calculation of the EAD is done in the following 6 steps:

1. Each transaction is mapped into separate payment and receiver legs: a transaction in which a financial instrument is exchanged for a payment has one payment leg. A transaction in which a payment is exchanged for another payment has two payment legs.
2. The effective notional and the modified duration (when applicable) are calculated.
3. The notional equivalent amount is calculated for each transaction type.
4. For each hedging set, the absolute net exposure is weighted with the credit conversion factor (CCF).

5. The current market value of the transaction is calculated.
6. The maximum of the total current market value and the sum of the CCF weighted amounts is taken and the result is scaled with  $\beta = 1.4$ .

The calculation is illustrated in Table 6.14 for a US bank's portfolio with two interest rate swaps, one foreign exchange swap, one cross-currency swap and a total return swap [62].

*Internal models method:* it is the most risk-sensitive method to calculate the counterparty credit risk exposure. Under this approach, the exposure and maturity are calculated internally. For the internal calculation, it is judged that the effective expected positive exposure (eff. EPE) is the best measurement for the exposure at default:

$$\text{EAD} = \alpha \times \text{Eff. EPE.} \quad (6.14)$$

The effective EPE measure has been defined in section 4.4.3.3. A common approach is via Monte Carlo simulation techniques, but analytic expressions have also been proposed in the literature. Like all internal models, the modelling needs to be done with sufficient accuracy and all relevant risk sources should be included. Note that the internal model approach allows cross-product netting as it is allowed to take into account correlations between risk factors that determine the effective EPE.

The scaling factor  $\alpha$  is set by the BCBS at 1.4. It mainly takes into account wrong-way risk (dependence of counterparty default risk and counterparty credit risk exposure), but also covers other granularity effects and particularly high correlations. Banks may motivate a lower scaling factor because of their specific portfolio composition. Local supervisors may determine other scaling factors when necessary. Note that the scaling factor  $\alpha$  is floored at 1.2 by the BCBS.

The general maturity rules are applicable as will be discussed below. When the original maturity of the longest-dated contract in the set exceeds one year, the following specific formula is applied to calculate the effective maturity  $M$  used in the capital formulae

$$M = \frac{\sum_{q, 0 < t_q \leq 1y} \text{Eff. EE}_q \times \Delta t_q \times df_q + \sum_{q, 1y < t_q \leq \text{mat.}} \text{EE}_q \times \Delta t_q \times df_q}{\sum_{q, t_q \leq 1y} \text{Eff. EE}_q \times \Delta t_q \times df_q},$$

where  $q$  is a discrete time index,  $t_q$  is the time the exposure is measured,  $\Delta t_q = t_q - t_{q-1}$  is the time between subsequent exposure measurements and where  $df_q$  is the risk-free discount factor for the future time period  $t_q$ . At  $t_0$ , the effective EPE equals the current exposure. In other cases, one

**Table 6.14** Illustration of the standardized method for exposure calculation of counterparty credit risk. The US bank's exposure equivalent is calculated for a portfolio with two interest rate swaps ( $i = 1, 2$ ), a foreign exchange rate swap ( $i = 3$ ), a cross-currency swap ( $i = 4$ ) and a total return swap on the French CAC40 stock index ( $i = 5$ ) [62].

$i$	Transaction information				CMV	Interest rate risk ( $j$ )						FX risk ( $j$ )		Eq. risk ( $j$ )
	swap	leg	effective notional (mln USD)	modified duration (years)		CMV <sub><math>i</math></sub>	USD non-gov $M \leq 1$ not. ×dur.	5 < $M$ not. ×dur.	EUR non-gov $M \leq 1$ not. ×dur.	5 < $M$ not. ×dur.	JPY non-gov $M \leq 1$ not. ×dur.	5 < $M$ not. ×dur.	EUR/ USD ±not.	
1	USD IR	receiver	70	8	−6.000			560						
1	USD IR	payer	70	−0.2		−14								
2	USD IR	receiver	250	0.125		31.25								
2	USD IR	payer	250	−5.5	2.000		−1375							
3	EUR FX	receiver	80	15	0.000				1200			80		
3	USD FX	payer	80	−0.125		−10.000								
4	EUR cross ccy	receiver	50	6	1.000				300			50		
4	JPY cross ccy	payer	50	−6						−300			−50	
5	CAC tot. ret.	receiver	200	0.125	4.000			25				200		
5	CAC tot. ret.	payer	200											−200
Net risk position per hedging set $j$ ( $\sum_i RPT_{ij}$ )						7.25	−815	25	1500		−300	330	−50	−200
Abs. net risk position per hedging set $j$ ( $ \sum_i RPT_{ij} $ )						7.25	815	25	1500		300	330	50	200
Credit conversion factors (CCF <sub><math>j</math></sub> )						0.20%	0.20%	0.20%	0.20%		0.20%	2.50%	2.50%	7.00%
CCF weighted amount per hedging set $j$ (CCF <sub><math>j</math></sub>   $\sum_i RPT_{ij} $ )						0.0145	1.6300	0.0500	3.0000		0.6000	8.2500	1.2500	14.0000
Aggregated results: hedging set exposure measurement														
Current market value ( $\sum_i CMV_i$ ) (mln USD)										1.0000				
Sum of CCF weighted amounts ( $\sum_j CCF_j   \sum_i RPT_{ij} $ ) (mln USD)										28.7945				
Maximum of CMV and sum CCF weighted amounts (mln USD)										28.7945				
<b>EAD</b> = $\beta \max(CMV, \sum_j CCF_j   \sum_i RPT_{ij} )$ (mln USD)										<b>40.3123</b>				

applies the maturity guidelines discussed below. The maturity is capped at 5 years.

In the case of margin agreements, the exposure risk is reduced to the margin threshold plus an add-on for the increase of exposure during the margin period of risk as discussed in section 4.4.3.3. If the bank's model takes into account the margining agreement, the EAD is still obtained as in eqn 6.14 based upon the bank's effective EPE. Because such models are quite advanced, the BCBS requests specific supervision of such models by local supervisors. An alternative approach that is recognized by the BCBS is to calculate the exposure add-on during a minimum margin risk period and calculate the effective EPE as the lowest of the effective EPE without margin agreement and the threshold with add-on.

Because the internal models method is the only method that allows recognition of cross-product netting, capital requirements are expected to be lower. It will stimulate banks to apply the most advanced exposure risk method.

**Effective maturity (M)** The impact of the effective maturity in IRBAf is very limited. The advanced approach allows for more risk sensitivity. In most cases, the measurements are technically simple, but may require, nevertheless, significant IT efforts.

*Foundation IRBA* In the foundation IRBA method, the effective maturity  $M$  that is applied in the risk weight functions, is put equal to 2.5 years. For certain short-term (repo-style) transactions, the maturity is 0.5 year. National supervisors may determine other maturity levels.

*Advanced IRBA* In the advanced approach, banks are required to measure the effective maturity of the material facilities. The effective maturity is the cash flow weighted payment maturity

$$\text{Effective maturity} = \frac{\sum_k t_k \text{CF}_k}{\sum_k \text{CF}_k}, \quad (6.15)$$

with  $\text{CF}_k$  the cash flow at time or period  $t_k$  from now ( $t = 0$ ). The calculation is illustrated in Table 6.15. The cash flows can be principal, interest payments or commissions. When it is not possible for the financial institution to calculate the effective maturity, a more conservative measure is taken that is equal to the maximum remaining time that the borrower is permitted to take full discharge of its contractual obligation. In many cases

**Table 6.15** Calculation of effective maturity for a facility with 6 remaining payment dates. The effective maturity is capped at 5 years and floored at 1 year, except for nationally recognized short-term facilities.

Payment Nr.	1	2	3	4	5	6	Total
Time	0.5 y	1.0 y	1.5 y	2.0 y	2.5 y	3.0 y	
Cash flow	100	100	100	100	100	600	1100
Time × cash flow	50	100	150	200	250	1800	2550
<b>Effective maturity</b>							<b>2.32 y</b>

this corresponds to the remaining nominal maturity, which is 3 years for the example of Table 6.15. Rules exist on how to apply the formula for derivative products with non-deterministic cash flows and that are part of a netting agreement. For example, in the latter case, one uses the notional amount of the transactions to weight the maturity. The effective maturity is capped at 5 years and floored at 1 year. National supervisors may exempt the calculation of the effective maturity for smaller domestic borrowers with both turnover and total assets less than €500 million. For these borrowers, the average maturity is equal to 2.5 years as in the foundation approach.

The lower cap does not apply to certain short-term exposures defined by the BCBS and on a national basis by local supervisors. These short-term trading book exposures need to have an original maturity less than 1 year. Not all short-term exposures are recognized, because some types of contracts will be almost automatically renewed, especially when the bank has a strategic commercial relation with the counterpart. The following products may not be subject to the 1-year floor:

1. Examples of eligible short-term exposure contracts recognized by the BCBS in section 321 of [63], are OTC derivatives, margin lending and repo-style transactions with original maturity less than one year, daily remargining and that are almost fully collateralized. With these conditions, the risk is greatly reduced, which justifies a lower risk weight via a lower maturity. The effective maturity is calculated from eqn 6.15 and is subject to a floor of 1 day.
2. In addition to these rules, other short-term products, that are not part of a strategic customer relation, can also be eligible for a lower maturity. An indicative list is given in section 322 of [63]:
  - (a) Some capital market-driven transactions and repo-style transactions other than defined in section 321.



- (b) Some short-term self-liquidating trade transactions like import and export letters of credit.
- (c) Some exposures arising from settling securities purchases and sales, including short-term overdrafts from failed securities settlements.
- (d) Some exposures arising from cash settlements by wire transfer, including short-term overdrafts.
- (e) Some exposures to banks arising from foreign-exchange settlements,
- (f) Some short-term loans and deposits.

These products are defined by the local supervisor after a careful review of the local market practice.

In all cases, the maturity  $M$  is capped to 5 years.

**6.3.1.2.B.2 Retail exposures** For retail exposures, banks must provide their own estimates of PD, LGD and EAD for both the foundation and advanced approach. Hence, there is no foundation approach for retail. A key concept of retail exposures are homogeneous pools on which one measures borrower and transaction risk. Each exposure is assigned to a pool. Such pools reflect the following risk drivers: borrower risk characteristics (borrower type, demographics, age, ...), transaction risk characteristics (loan to value, guarantees, ...), and delinquency of the exposure.

**Probability of default (PD)** The PD is estimated on homogeneous pools. A floor of 0.03% or 3 bps is applicable. The PD is measured on a homogeneous pool of counterparts or on a homogeneous pool of products. Internal data is regarded as the primary source for estimating the PDs. External or pooled data can be used when there exist strong links concerning the way exposures are linked to a pool and the corresponding risk profiles.

The pool PD can be estimated as the long-term average of the one-year default rates (as for firms), or inferred from the pool loss divided by the empirical LGD. Irrespective of which data sources are used, the minimum length for the estimation is 5 years. Longer periods are preferred if possible. Banks may give unequal importance to different historical periods if it yields a better prediction.

A special point of attention in the calibration of retail PDs are seasoning effects that peak several years after origination. Banks are encouraged to adjust PD estimates for such effect, especially on fast-growing portfolios.

The effect of risk mitigants is taken into account either in the PD or LGD individually, or on the whole pool. The double-default effect is allowed under the conditions mentioned for firm exposures.

**Loss given default (LGD)** The LGD on a pool can be estimated in two ways. The first approach is a direct measurement of the economic loss per portfolio. The second approach is to infer the LGD from the loss and the PD. The LGD is estimated on a minimum time period of at least 5 years.

Because of the potential of long-run cycles in housing prices, short-term LGD data may not capture such effects. Therefore, the minimum applicable LGD is floored to 10% for residential mortgages during the transition phase (3 years), except for sovereign guaranteed issues. During the transition period, the floor will be evaluated by the BCBS.

**Exposure at default (EAD)** The EAD must reflect both on- and off-balance sheet exposures. Undrawn amounts can be reflected either in the LGD or in the EAD estimates. Netting of exposures is allowed.

For uncertain retail exposures like credit cards, the future drawdown is based upon the history and expectation of losses. The EAD is estimated on a minimum observation period of at least 5 years for at least one data source. The calibrated EAD average is a default-weighted average. It is not a time-weighted average. The default-weighted average puts higher weight on downturn periods that exhibit a high number of defaults.

**Effective maturity (M)** There is no maturity adjustment for retail exposures.

**6.3.1.2.B.3 Equity exposures** The risk weighted assets of an equity exposure in the trading book are treated with market risk capital rules. Banking book equity exposures can be calculated by either one of two broad approaches:

1. **Market-based approach:** The simple risk weight method and the internal models method are the two options possible:

- (a) *Simple risk weight method:* A risk weight of 300% is applied to publicly traded equity holdings, that are traded on a recognized security exchange. To all other equity holdings, a risk weight of 400% is applied. The exposure can be adjusted by short positions or derivative instruments that are designated explicitly as hedges.

(b) *Internal models method*: The internal model is a value-at-risk model that estimates the 99th percentile of the loss. The loss is defined as the difference between the quarterly returns and the long-term risk-free rate. The VaR is calculated on a sufficiently long time period. The risk weight is obtained as  $12.5 \times \text{VaR}(99\%)$ . The exact calculation method<sup>89</sup> (variance-covariance, historical simulation or Monte Carlo) is not prescribed, it is up to the bank to provide a sound estimate that covers all material risks. The estimate should be robust for adverse market movements that are relevant for the long-term risk profile of specific positions. The VaR should be estimated on the longest time period for which data are available and meaningful. It includes specific actions and methods for non-linear products as well as the use of correlations between equity returns that may increase or reduce the risk. These risk weights are floored at 200% for publicly traded equity holdings and 300% for others (taking into account a correction for expected loss). Collateral is not recognized, but guarantees are recognized. A stress-testing scheme for the model, including its assumptions and parameters, needs to be in place.

2. **PD/LGD approach**: The PD/LGD approach for equity exposures is the same as for firm exposures using regulatory risk weight functions including companies in the retail asset class. There are some additional specifications and restrictions.

**Probability of default (PD)** The PD for an equity exposure should be the same as for debt exposures in the same company. When no debt position is held in the same company, but other standards are met, a scaling factor of 1.5 is applied to the risk weight function.

**Loss given default (LGD)** The LGD is prescribed to be equal to 90%. There is no advanced approach for equity exposures. Hedges on PD/LGD equity exposures are recognized following the approach for firm exposures with an LGD of 90%.

**Effective maturity (M)** The maturity adjustment is put to 5 years.

<sup>89</sup> See section 6.3.2 for details on the calculation methods.

**Exposure at default (EAD)** For the calculation of the capital requirement, the exposure at default for an equity exposure is based upon the value in the financial statements (fair value or market value).

**Specificities** A minimum risk weight of 100% is applicable for public equities that are part of a long-term customer relationship and for private equities where the return on investment comes from regular periodic cash flows that are not derived from capital gains. For all other equity positions (including net short positions), the capital charge should not be less than 200% and 300% for public equity and all other equity holdings, respectively.

The choice between both approaches is made by local supervisors as well as the circumstances for which they have to be applied by banks. Note that for a maximum of 10 years some particular equity investments held at the time of publication of the Basel II Capital Accord may be exempt from the IRBA treatment when agreed by the supervisors.

Some counterparts can be excluded from the market-based and PD/LGD approach, e.g., counterparts with zero risk weight, specific promoted sectors and non-material positions. For a maximum of ten years, supervisors may exempt from the IRB treatment particular equity investments held at the time of the publication of the new framework. This period is called the transitional period or grandfathering period. More details on the regulatory treatment of equity exposures can be found in section 339–361 [63].

**6.3.1.2.B.4 Purchased receivables** When purchased receivables belong to one specific asset class, the IRBA weight for that specific asset class is applicable. In the case of hybrid pools, one uses the risk weight function for the different asset types. In the case of limited information or insufficient compliance with minimum requirements, one applies the most conservative risk weight function. For example, the small-size adjustment for small and medium enterprises is only applicable when the average firm size in the pool is known. If unknown, the asset correlation adjustment is not applied.

To quantify the risk of purchased retail exposures, the bank has to follow the standards for (internal) retail exposures. An extension is that the bank may also use the external and internal reference data. The risk quantification must estimate the risk of the receivables on a stand-alone basis, net from any form of guarantees. For purchased firm receivables risk quantification, the expected approach is the application of a bottom-up approach where

the risk for each individual exposure is determined. Subject to supervisory permission, a bank may also use a top-down approach where the stand-alone expected loss is calculated on the pool and split up into PD and LGD.

For this type of exposure, a double capital charge is applicable. The classical credit risk capital charge covers the credit risk. In addition, a dilution risk capital charge is applicable. The dilution risk is present because the receivable amount may be reduced through cash or non-cash credits to the receivable's obligor. This may, for example, occur when sold goods are returned or the quality is disputed [63].

**Capital charge for credit risk** In the foundation approach, there are multiple options to calculate the PD, LGD, EAD and M:

1. The EL cannot be decomposed into the PD and LGD and the claims are only senior claims to firms: the LGD of 45% is used; the PD is obtained as the EL divided by the LGD and the EAD is the amount outstanding minus the dilution risk capital charge.
2. The EL cannot be decomposed into the PD, but the senior firm claims cannot be shown: the LGD is put equal to 100%, the PD is put equal to the EL and the EAD is the amount outstanding minus the dilution risk capital charge.
3. The PD can be estimated in a reliable manner: the firm risk weights are applicable as well as the foundation rules for LGD, EAD and M follow the rules for firms in the foundation approach. In the case of revolving purchase facilities, the EAD is the current drawn amount plus 75% of undrawn commitments minus the capital charge for dilution risk.

In the advanced approach, the rules to estimate the PD and LGD for a pool via the expected loss as for the retail approach, with some constraints on the LGD estimate.

Internal EAD estimates are not allowed. The EAD is the amount outstanding minus the dilution risk capital charge, augmented with 75% of the undrawn amount for revolving purchase facilities. The maturity  $M$  of the pool is equal to the exposure weighted average effective maturity (as defined for firms). For undrawn amounts the same maturity is applied if certain protective conditions are met, otherwise one applies the remaining maturity or the longest-dated potential receivable date.

**Capital charge for dilution risk** The dilution risk is measured using a bottom-up or top-down approach. The key parameter to be estimated is the stand-alone one-year expected loss due to dilution risk as a percentage of

the total receivables amount. The firm risk weight function (eqns 5.42–5.46) is applied with the following parameters:

**PD:** the PD must be set to the estimated EL.

**LGD:** the LGD is put equal at 100%.

**M:** a specific treatment ( $M = 1$ ) may be allowed by supervisors if the bank can demonstrate that the dilution risk is adequately monitored and managed to be resolved within one year.

The application of the firm risk weight rule is applicable to all types of purchased receivables. The use of the above risk parameters does not necessarily have the same interpretation as for credit risk, but their use in the risk weight rule provides the required capital amount defined by the Basel Committee on Banking Supervision.

**Treatment of purchase price discounts** A classical industry approach is that the purchase price of the receivables includes a discount that reflects the default credit risk losses and/or the dilution risk losses. This discount can be considered as a first loss protection in a securitization framework, of which a part may be refunded to the seller. This refundable part can be treated as a first loss protection in the securitization framework. The same holds when collateral or partial guarantees are used to cover these risks, they are treated under the same framework as well.

**Risk mitigants** The credit risk mitigation falls under the general framework for the other asset classes. Specific to this asset class are whether third-party guarantees cover credit default risk, dilution risk or both. When the guarantee covers both risks, the sum of both risk charges will be substituted by the guarantor's risk weight. When the guarantee covers only both, only the corresponding risk weight will be substituted and the other is added. In the case of partial coverage, the risk weights will be applied proportionally as in the general rule for partial coverage.

**6.3.1.2.B.5 Securitization exposures** The framework for securitization is specific and different from the other asset classes. For this reason, a separate section (section 538–643 [63]) is dedicated to this asset class in [63]. Apart from the standardized approach, the regulation foresees a hierarchical list of approaches:

1. The ratings-based approach (RBA) is applied to all securitization exposures that are rated or that are unrated but for a rating that can be inferred

from a rated reference exposure. Amongst others, the reference asset needs to be subordinated to the unrated exposure, have lower or equal maturity.

2. For asset-backed commercial paper programmes, the internal assessment approach is allowed. The internal credit quality assessments need to be mapped to equivalent ratings of an ECAI.
3. The supervisory formula (section 623–4 [63]) is applied for the other exposures that are not treated by one of the above options. The capital charge depends upon 5 variables that need to be calculated by the bank:
  - (a) The IRBA capital charge in case the underlying exposures were not securitized.
  - (b) The credit enhancement level is the ratio of the amount of all the securitization exposures subordinate to the concerned tranche with respect to the total amount. It is a measure for the relative seniority.
  - (c) The thickness of the exposure measures the relative thickness of the tranche compared to the pool. It is the ratio of the nominal size of the tranche concerned with respect to the nominal amount of exposures.
  - (d) The effective number of exposures  $N^*$  is measured via the HHI index defined in eqns 5.15 and 5.16.
  - (e) The LGD of the pool is measured as the exposure weighted average LGD.

Except for the supervisory formula approach, the other approaches do not yield a risk weight. The risk weight depends upon the long-term rating, the seniority and the granularity of the pool as explained in Table 6.16. A similar table is available when using short-term ratings. Note that the risk weights depend on the rating, not on the PD, LGD or maturity as for the other asset classes. The CCF for off-balance securitization exposures is equal to 100%, except for eligible liquidity facilities for which the CCF is 20% if the maturity is less than 1 year and 50% for exposures with an original maturity exceeding 1 year. Eligible liquidity facilities with cancellable servicer cash advances, overlapping exposures or that are only available when a market disruption occurs, may receive a zero CCF. Further details on this specific asset class can be found in section 538–643 [63].

**Table 6.16** IRBA risk weights for securitization exposures. For senior tranches in a sufficiently granular pool ( $N^* \geq 6$ ) the risk weights of the second column apply. For non-granular pools with  $N^* < 6$ , the risk weights of the fourth column apply. The third column is applicable for other exposures.

Rating	Sr. RW	Base RW	Non-Gr. RW
AAA	7%	12%	20%
AA	8%	15%	25%
A+	10%	18%	35%
A	12%	20%	35%
A–	20%	35%	35%
BBB+	35%	50%	50%
BBB	60%	75%	75%
BBB–	100%	100%	100%
BB+	250%	250%	250%
BB	425%	425%	425%
BB–	650%	650%	650%
<BB–	deduct.	deduct.	deduct.
Unrated	deduct.	deduct.	deduct.

### 6.3.1.2.C General minimum requirements (IRBA)

**6.3.1.2.C.1 Rating structure** The bank must have a meaningful distribution of exposures across different risk borrower- and facility-rating grades without excessive concentrations.

The minimum number of borrower risk grades is equal to 7 for non-defaulted borrowers and one for defaulted exposures. Supervisors may require more grades. Rating grades can have “+” and “–” or alpha-numeric modifiers. These qualify as different exposures if different PDs are assigned. The number of PD grades has to ensure sufficiently different rating grades in the risk spectrum that is meaningful for the bank’s exposures.

There is no minimum number of LGD grades for advanced IRBA banks. Empirical evidence has to support the number of grades. One must avoid the situation that LGD values vary widely in a single grade.

For each identified retail pool, the bank must be able to quantify the risk measures (PD, LGD and EAD). The number of pools has to ensure a sufficiently good differentiation of the bank’s portfolio.

**6.3.1.2.C.2 Rating criteria** A bank must have specific rating definitions, processes and criteria to assign exposures to the risk grades. The grade descriptions and definitions need to be sufficiently detailed to ensure consistent rating assignment across different business lines, departments and



geographic locations. These rating definitions and descriptions have to be understandable for third parties, like, e.g., auditors and supervisors. The criteria have to be consistent with the internal lending standards and policies.

The rating assignment must take into account all available information, which also encompasses external ratings. The less information the bank has, the more conservative is the rating grade assignment.

**6.3.1.2.C.3 Rating assignment horizon** The PD is estimated on a one-year horizon. A longer time horizon is expected for the rating assignment. The borrower rating should reflect the risk during adverse or stress scenarios, which indicates the preference for through-the-cycle (TTC) ratings discussed in Chapter 3. Because future stress scenarios are difficult to predict, a conservative bias is applied in the assessments.

**6.3.1.2.C.4 Use of models** Statistical and other mechanical procedures for PDs, LGDs and EADs are allowed as a primary or partial basis of rating assignments and LGD estimation. Such systems may reduce human errors and ensure consistency. Human judgment and oversight are considered by the BCBS to remain necessary to ensure that such models function correctly, e.g., in the absence of sufficient information, and take all relevant information into account in the risk assessment.

The use of such models involves a set of additional requirements:

1. The burden is on the bank to satisfy its supervisor that the model has a good predictive power and that the model uses a reasonable set of explanatory variables. The use of a model should not result in material biases and distorted capital requirements.
2. The bank must have processes and systems to vet data inputs into the statistical or mechanical system and to check the data accuracy, appropriateness and completeness.
3. The bank must demonstrate that the model reference data sets on which the model has been developed is representative of its portfolio.
4. When model results are combined with human expert judgment, the latter needs to take into account all factors not considered by the model. Guidelines are required to indicate how to combine both assessments.
5. Procedures need to be defined for human expert review of model-based assignments to reveal possible biases and model weaknesses.
6. The bank must have a regular cycle of model validation to check model accuracy, performance and stability.

The use of statistical risk estimates is preferred in a Basel II context [63]. Nevertheless, the bank should not rely blindly on its models and needs to foresee procedures for ongoing performance and reliability checks on its models. These issues are treated in book III.

**6.3.1.2.C.5 Documentation** The bank must document the design, the implementation and use of its rating systems. This documentation must evidence the banks' compliance with minimum standards. The documentation includes the rating process and frequency, internal control, the default definition and loss estimation. For statistical models, one needs to outline the model theory, out-of-time and out-of-sample performances, as well as known model weaknesses. The documentation requirements also hold when vendor models are applied.

**6.3.1.2.C.6 Rating system coverage** The ratings assigned by the banks should cover a sufficient number of counterparts and exposures. For firm, sovereign and bank exposures, each borrower and also each recognized guarantor and corresponding facilities the bank is exposed to, need to be rated. For retail, each exposure needs to be assigned to a pool. The rating coverage requirements concerns each legal entity the bank has exposures to. This may involve special rating procedures for connected groups.

Ratings need to be assigned at least annually. Sensitive and high-risk exposures need to be reviewed more frequently. The rating has to be assigned by an independent department in the bank that does not have any commercial interest in the transactions. Sufficient information and data need to be available to assign such ratings.

The override procedure needs to be clearly described and documented: guidelines, authorization, number of notches overruling, . . .

The bank must store sufficient data history to allow a wide variety of tasks related to modelling, model review, backtesting and validation. These data include the date and time of a rating assignment as well as key variables used to assign the rating, default information, etc. Advanced IRBA banks should, a.o., also calculate the elements to assign LGD and EAD estimates, and the outcomes in case of default. Foundation IRBA banks that use supervisory estimates are not required to store this information, but are advised to do so. For retail, similar data-storage requirements hold related to the pool definition, pool assignment, and risk parameter estimates.

Banks are required to have sound stress-test scenarios in place to assess their capital adequacy. Such stress-test scenarios are complementary to the

risk weight function and assess the impact of severe, but plausible scenario's on the bank's capital adequacy. Such scenarios could be a major economic or industry downturn period, market crash or related risk events and severe liquidity conditions. The stress-test scenarios are reviewed by national supervisors. Stress testing is discussed in book III.

**6.3.1.2.C.7 Firm governance and oversight** The firm governance and oversight involves the following 3 aspects:

1. **Firm governance:** The bank's board of directors or a designated committee and the senior management must approve all material aspects of the rating and estimation processes. The senior management must have a good understanding of the rating system design and its operation. It is responsible for a good functioning of the rating system. The reporting to the senior management must include, a.o., the rating grades used (exposure per rating, migrations, predicted and realized loss per grade).
2. **Credit-risk control:** Independent credit risk control units should exist in the bank that design or select rating systems, verify the rating procedures and predictive power of the risk drivers, and review and document changes to the rating process.
3. **Audit:** Internal and external audit, or an equally independent function, must review at least annually the rating system and its operations. The findings of the audit must be documented.

**6.3.1.2.C.8 Use of internal ratings** The internal rating system and resulting ratings for regulatory capital calculations have an essential role in the organization (see Chapter 3). An additional advantage of the extensive use of ratings in the organization is that possible shortcomings and material biases will be detected earlier. It is not accepted that ratings and rating systems are used for regulatory capital calculations only. The bank must have a considerable track record (at least three years) of its internal ratings information prior to qualification.

**6.3.1.2.C.9 Risk quantification** The risk quantification considers PD, LGD and EAD estimation. The general rules for all asset classes are summarized below. Specific rules for the different asset classes have been discussed above. An overview of risk measurement has been given in Chapter 4.

The internal estimates for PD, LGD and EAD must incorporate all possible information. Both internal, pooled and external data can be used. The bank

has to prove that its estimates are representative of the long-term risk experience, and that the data on which the estimates are made are representative of the bank's portfolio.

The estimates are based upon historical empirical experience. Empirical evidence is preferred above human expert judgment. The estimates need to be reviewed at least annually. The out-of-sample and out-of-time calibration backtest is discussed in book III. It implies that banks also collect and store the data necessary for such backtests. An extensive overview of measurement and calibration techniques is given in book II.

**Probability of default (PD)** The cornerstone of the uniform risk quantification is the default definition discussed in section 4.4.1.1. The default definition is applicable on the counterpart or borrower level for banks, sovereign and firm counterparts. For retail exposures, the default definition is applicable on counterpart–product combinations.

**Loss given default (LGD)** The LGD that is to be estimated for each facility needs to reflect the economic loss in the case of downturn conditions. The calculation of the LGD has been discussed in section 4.4.2. The calibrated LGD may not be lower than the default-weighted average LGD. Where possible, LGD estimates are grounded in historical recovery rates and are not estimated only on the market value estimates of collateral.<sup>90</sup> If one observes that the LGD is higher during periods of high default rates, the average during downturn periods should be used. The definition of downturn periods has to be given by the banks. The downturn LGD calibration is discussed in book II. The LGD estimates must incorporate downturn and cyclical effects.

The Basel II Capital Accord accepts that the calibrated average LGD may not be applicable to each individual case. Whereas calibrated LGD values are applicable for all exposures, more information becomes available in the case of a default. For defaulted assets, banks are required to determine best estimate losses. The difference from the calibrated LGD follows the rules of section 5.7.1.

**Exposure at default (EAD)** The EAD for an on-balance sheet and off-balance sheet exposure is defined as the expected gross exposure of the facility upon default of the obligor. For an on-balance sheet exposure, the

<sup>90</sup> Sometimes, banks may observe difficulties in the liquidation of the collateral.

EAD estimate is not less than the current amount drawn (including the effect of netting as in the foundation approach). Advanced banks are required to follow specific procedures for off-balance sheet exposures (excluding derivatives). In the advanced approach, banks are requested to have EAD estimates for off-balance sheet items that reflect additional drawings of the borrower up to and even after the default event occurs.

The EAD estimate has to be a long-run default weighted average EAD for facilities and borrowers with similar characteristics. The EAD estimate is adjusted upward in the case of a positive correlation between the EAD and PD; the EAD has to be calibrated for economic downturn conditions. A margin of conservativeness is required in all cases to capture possible estimation errors.

The risk drivers that explain the differences in the EAD need to be intuitive and plausible; and need to be supported by the financial analysts. The bank should also consider its policies and strategies for account monitoring, the prevention of drawings short of default and, the management of exposure risk in general.

**6.3.1.2.C.10 Guarantees** The risk mitigating effect of guarantees can be reflected by an adjustment of the PD and LGD estimates. Of course, the option to adjust LGD values is valid only for banks applying internal LGD estimates.<sup>91</sup> The adjustment of PD and LGD may not result in a lower capital requirement than a direct exposure to the guarantor. The adjusted risk weight must not reflect the risk mitigation of double default (see book II). A recognized guarantor needs to be rated on an ongoing basis.

The adjustment of borrower grades and LGD needs to follow specific guidelines and procedures in the bank that are clear and easy to interpret for third parties. Ratings and risk assessments should not observe any known biases and follow the rules as for the other risk assessments. The criteria must be plausible and intuitive, and must address the guarantor's ability and willingness to perform under the guarantee (section 486 [63]). Residual risks should also be taken into account as well as all other relevant information.

The minimum requirements for guarantees are also applicable to single-name credit derivatives. Additionally, asset mismatches are considered to

<sup>91</sup> For banks that use the foundation LGD values, the LGD adjustment option is not allowed. The eligible guarantors and guarantees are those of the standardized approach and internally rated companies with a rating better than or equal to A-.

ensure that the risk mitigant provides a protection against the risk. In practice, it can occur that the underlying of the credit derivative does not match exactly with the bank exposure of which one wants to mitigate the risk. This can occur, e.g., when the risk mitigant considers other default definitions or concerns other debt products of the same counterpart. The criteria for adjusting borrower grades or LGD estimates must require that the underlying asset cannot be different from the asset for which protection is bought unless conditions in the foundation approach are met. One should also consider payout structures and timing of recoveries.

**6.3.1.2.C.11 Validation** As indicated at the end of Chapter 4, banks are required to have an internal validation process to validate the accuracy and consistency of rating systems, processes and the risk component estimation. Validation and backtesting are discussed extensively in book III.

**6.3.1.2.C.12 Documentation** The burden is on the bank to satisfy its supervisor that its models function correctly and that the resulting regulatory capital requirements are not distorted. The documentation concerns the model design, operation, use, and perimeter. The responsible persons for model design, application, approval, and review need to be documented. The documentation needs to demonstrate to the regulator that the bank is compliant with the minimum qualitative and quantitative requirements specified above. All the critical elements of the model should be documented

- 1. Internal model methodology:** The choice of the internal model methodology has to be motivated. The model performance and reviews are reported, as well as model changes and evolutions over time.
- 2. Model theory and test results:** The model documentation should include a detailed outline of the data, theory and assumptions used to construct the model; and a statistical review process that includes out-of-time and out-of-sample validation. Model weaknesses and circumstances in which the model does not function adequately must be reported.
- 3. Approximation and mappings:** Where approximations and mappings are used, it needs to be documented that all chosen proxies and mappings are sufficiently representative for the risk of the own portfolio.

**6.3.1.2.C.13 Disclosure** To be eligible for the IRBA approach, banks must meet the disclosure requirements of pillar 3 that is discussed in section 6.5.

### 6.3.2 Market risk (pillar 1)

Market risk is part of the pillar 1 minimum capital requirements as depicted in Fig. 6.2. The market risk capital charges were introduced in the 1996 amendment as a response to increased proprietary trading activities. The market risk capital charges provide an explicit capital cushion for the price risk to which banks are exposed. The amendment provides essentially 2 approaches to compute the market risk capital charge (Table 6.3): the robust, conservative and rigid standardized method where the capital charges are provided by the Basel rules and added up; and the internal models approach based on internal market risk management systems allowing a more risk-sensitive and adaptable approach. The increased risk sensitivity and flexibility are an incentive for banks to comprehend their market risk. From a regulatory perspective, the introduction of the internal model approach was the first time that the regulatory capital charges could rely upon internal bank estimates. However, the internal estimates are subject to a strong reviewing and verification process called backtesting. In addition, stress testing is applied to quantify the impact of stress events that greatly impact the bank and are not captured by the typical VaR models.

In order to define the scope of the market risk capital rules, the 1986 trading book definition of [44] was updated in 2006 [63]. A precise definition is given in section 684–718 [63]. Paragraph 685 specifies that the trading book consists of positions of financial instruments and commodities held either with trading intent or in order to hedge other elements of the trading book. These instruments must be free of restrictive trading covenants or one must be able to hedge them completely. The portfolio has to be actively managed and trading book positions should be frequently and accurately valued. The positions are held intentionally for short-term resale and/or with the intent of benefitting from expected/actual short-term price movements or arbitrage. The trading book eligibility and the border between the banking book and trading book are specific attention points in pillar 2.

Note that trading book exposures also bear credit risk. The specificities of the trading book exposures have been taken into account via specific rules for the double-default framework, counterparty credit risk exposure, short-term maturities (<1 year) and failed trades, that were discussed in section 6.3.1.

#### 6.3.2.1 Standardized approach (SA)

The standardized approach applies a building block idea in which the market risk is computed in turn for portfolio's exposed to interest rate risk (ir),

equity risk (eq), foreign currency risk (fx), commodity risk (co) and option risk (op) following the Basel guidelines, and then summing up the risk charges required for all 5 categories of market risk. The total market risk capital charge (MRC) is computed in the standardized (stnd) approach as

$$\text{MRC}_{\text{total}}^{\text{stnd}} = \text{MRC}_{\text{ir}}^{\text{stnd}} + \text{MRC}_{\text{eq}}^{\text{stnd}} + \text{MRC}_{\text{fx}}^{\text{stnd}} + \text{MRC}_{\text{co}}^{\text{stnd}} + \text{MRC}_{\text{op}}^{\text{stnd}}. \quad (6.16)$$

These capital requirements for the different risk types aim to cover two types of risk: specific risk and general risks. Specific risk refers to the risk that an individual security has a large change in market value. General risk reflects the probability of a loss due to a general change in market prices, e.g., interest-rate changes or a decrease of the major stock index.

The main advantages of the standardized approach are its ease of implementation, its robustness and conservativeness. On the other hand, it also has important disadvantages like, lack of risk sensitivity and too-conservative capital charges due to a lack of diversification benefits.

### **6.3.2.2 Internal model approach (IMA)**

In the internal model approach, the capital charges are calculated based on internal models and risk management systems. The more accurate and possibly lower capital charges are generally considered as an incentive for banks to develop a sound risk management system. The internal models are in many cases far more sophisticated and more up-to-date to adopt to new developments in the financial markets, than the rigid rules of the standard approach.

However, the use of internal models does not imply that the regulators have given up their authority. Indeed, the regulation imposes several conditions before applying the internal models:

1. The internal models can only be used after explicit approval by the supervisory authority.
2. The internal model needs to be sufficiently detailed and documented.
3. Banks applying the internal model approach have to satisfy various qualitative standards:
  - (a) Independent risk control unit: the responsibility of the risk control unit is to supervise and control the market risk teams and organization within the bank. In order to minimize potential conflicts of interest, the risk control has to be independent of the trading desks and reports directly to senior management.



- (b) A regular backtesting program has to be put in place to check and prove empirically the accuracy on the internal market risk models.
  - (c) Senior management and the board of directors need to be involved in the risk management and risk control process. Sufficient resources need to be allocated to the risk management.
  - (d) The bank has to satisfy the “use-test”. The results, VaR calculations, resulting trading limits, etc. have to be used in trading, management and strategic decisions. The risk management has to be integrated into the daily management of the bank. Situations in which the VaR is calculated internally for regulatory purposes are not only Basel compliant.
  - (e) The internal risk measurement models have to be used to define internal trading and exposure limits.
  - (f) Stress tests have to be performed regularly and results have to be reported and reviewed by the senior management and board of directors. Stress testing is further detailed in section 6.3.2.3.
  - (f) The bank should ensure compliance with a documented set of policies.
  - (h) The trading units and risk control units have to be reviewed by an independent unit or organization on a regular basis, at least once a year.
4. The internal model is subject to a rigorous backtesting process. The backtesting of market risk models will be further detailed in section 6.3.2.4.

Many of these qualitative requirements for the internal market risk management of the 1996 amendment have been adopted in the (advanced) internal-ratings-based approach to measure credit risk of the Basel II Capital Accord of 2004.

The internal market risk models have to satisfy a number of quantitative requirements to make sure that the VaR and hence also the capital cushion is accurately computed. The internal risk models have to contain a sufficient number of risk factors. When the interest rate risk is material, the yield curve has to be modelled with at least 6 factors and additional factors have to be used to model the spread risk. The equity risk has to be modelled by at least using a beta mapping to an appropriate index and can be further refined using industry or sector factors, and possibly also individual risk factors. In the case of active commodity trading, movements in spot rates and convenience yields have to be taken into account. For option risk, it is important that the

model captures the non-linear price characteristics including vega risk. To sum up, the models need to contain a sufficient number of risk factors, with sufficient complexity to capture all the risks of the products.

From a quantitative perspective, the VaR measures are computed from the models in a uniform way. The horizon used to compute the VaR is 10 trading days or 2 calendar weeks. The VaR limit is computed every business day using a 99% confidence interval. The observation period is based on at least one year of historical data, or half a year when using a non-equal weighting scheme. The market risk charge is obtained as:

$$\text{MRC}_t^{\text{IMA}} = \max \left( k \frac{1}{60} \sum_{i=1}^{60} \text{VaR}_{t-i}, \text{VaR}_{t-1} \right) + \text{SRC}_t. \quad (6.17)$$

The market risk charged is obtained as the highest of the previous VaR and the average VaR of the last 60 trading days times the multiplicative factor  $k$ . Taking the maximum, the VaR reacts promptly with suddenly increasing risk.

The multiplicative factor takes into account the fact that with a 99% VaR losses would occur in one 10-day period out of 100. It also provides a buffer against model mis-specifications. The value of the multiplicative factor  $k$  is set by local regulators. The minimal value is equal to 3. The multiplicative factor can be subject to additional charges when the backtesting results indicate that the bank is putting too little capital to cover adequately the risks.

The specific risk charge (SRC) provides a buffer against idiosyncratic risk factors like default and event risk. This term disappears when the bank can demonstrate that these specific risk elements are taken into account for the calculation of the VaR, and satisfies additional criteria specified in the BCBS regulation.

The calculation of the VaR consists typically of the following steps:

**Pricing model:** For each product or set of products, a pricing model is constructed. For example, options can be priced with the Black–Scholes equation [80]; the relation between bond price, yield changes and maturity is given by equations like eqns 5.30 and 5.31 [173, 376].

**Risk-parameter evolution:** The underlying risk parameters in the pricing models evolve according to synthetic or historical scenarios.

**Evaluation:** For each evolution of the risk parameters, the impact on the security and/or the whole portfolio of securities is analyzed.

**Risk measure:** From the multiple evolutions of risk parameters and corresponding evaluations, a loss distribution is obtained from which several risk measures (expected loss, value-at-risk, expected shortfall) are drawn similar to that for the loss distribution of a credit portfolio explained in section 5.3.

For market risk, the VaR measure catalyzed by the 1996 Amendment is still the most popular market risk measure at the moment of writing. For large portfolios, the above calculation method is often simplified by mapping securities to homogeneous buckets with similar sensitivity to risk drivers. Instead of evaluating each security, the impact of the risk-driver evolution is calculated on the buckets. In the literature, one considers 3 main approaches for VaR calculations [10, 78, 95, 260, 426] with varying complexity of the pricing models and the risk-driver evolutions:

**VaR/CoVaR approach:** The variance/covariance approach is the simplest VaR approach. It assumes that the portfolio can be adequately described as a linear combination of normally distributed risk factors. The resulting loss distribution is obtained assuming a normally distributed loss where the variance is calculated based upon the covariance matrix of the risk factors. The VaR/CoVaR approach is also known as the delta-normal method. The assumption of normality may not be the most suitable to capture the risk of extreme market movements that are observed in practice, but it simplifies the computational burden.

**Historical simulation:** The historical simulation method derives the VaR by taking a historical time series to estimate the losses on a product or portfolio. The method is simple to apply and does not require a lot of methodological assumptions. A disadvantage can be that past observations may not be representative of the current situation. If extreme events did not occur in the recent past, this will not impact the VaR calculations.

**Monte Carlo simulation:** The method is quite similar to the historical simulation method. Instead of a historical time series, a series of pseudo-random numbers is generated via Monte Carlo simulation. The advantage of the Monte Carlo simulation is that it is the most flexible method and does not assume linearity or normality. Its main disadvantage is the increased computational burden.

A simple model exhibits model risk because of its lack of accuracy. Nevertheless, the same may occur when a complex and difficult model is not well designed.

Banks are also required to put in place an incremental credit risk (ICR) measure to take into account the risks that are not included in the market VaR, e.g., the credit spread VaR. Such models that take explicitly default, spread and migration risk into account should be corrected for double counts with the existing market VaR, e.g., via surcharges or correction terms. There are no detailed guidelines available on the construction of these models. When the bank fails to develop an adequate approach, the IRB approach will be applied instead, resulting in much higher capital requirements.

### **6.3.2.3 Stress testing**

Banks that adopt the internal models approach for market risk have to apply stress testing to measure the ability of the bank's capital to absorb large potential losses. From a statistical perspective, the risk management and the risk parameters are typically designed during normal operating conditions, while the actual adequacy of the risk management matters under extreme market conditions. These extreme market events are located in the far tail of the loss distributions. With the current state of technology, it is not possible to provide sharp and exact loss estimates at high confidence levels in these tails as illustrated in Fig. 6.6. Therefore, it is market practice to apply stress testing to estimate the capital adequacy and to evaluate the losses in case of extreme stress events. Stress tests have become a standard technique complementary to VaR models. Stress tests are especially popular in cases where the deficiencies of VaR models (liquid market assumption, availability of historical data, difficulties with high-frequency price jumps and difficulties with highly non-linear exposures) become important and where the correlation between risk factors for extreme circumstances in the tail of the distribution becomes substantial.

Generally stress tests are tools used by financial firms to gauge their potential vulnerability to exceptional, but plausible events [118]. Several approaches are applicable for stress testing: scenario analysis, sensitivity analysis and stressing risk parameters. Scenario analysis and sensitivity analysis are reported as the most important stress tests in the international survey of the Committee on the Global Financial System (CGFS) [118, 183, 184].

In the case of scenario analysis, one applies various scenarios (e.g., equity, commodity, volatility, index rate, spread evolutions) to measure the value changes resulting from the valuation model of the portfolio. A scenario consists of simultaneous (up and/or down) moves of a number of risk

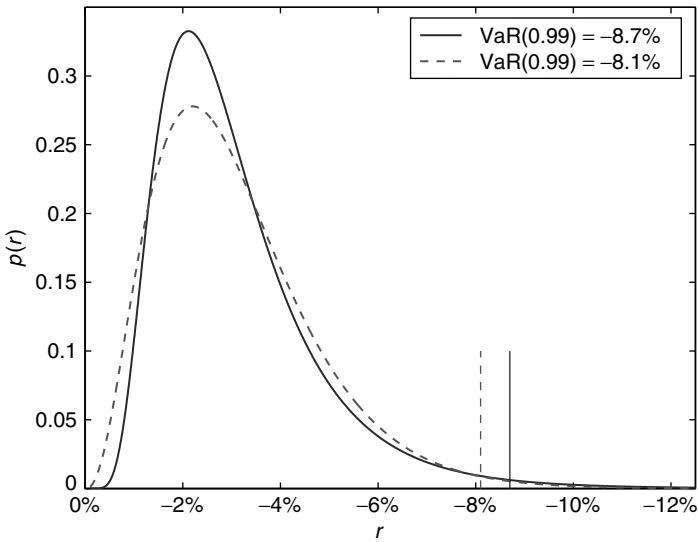

**Fig. 6.6** At high VaR levels, model-based approaches become very sensitive to the model assumptions. The graph illustrates two simple distribution functions with the same mean and variance that exhibit a 7.5% relative difference in their VaR(0.99). Stress testing complements statistical modelling.

factors:

1. Some scenarios require no simulation, by evaluating, e.g., the losses on a past stress period like the 1987 stock market crash and checking whether the bank is sufficiently protected by means of policies and capital to reduce its vulnerability towards such events. Evaluating past losses using historical scenarios, however, assumes that the portfolio is static, and it does not allow measurement of the impact of new products or portfolio composition.
2. Instead of analyzing past losses, one may also apply the past scenarios and time series to the portfolio and measure the portfolio valuation in the case of past stress scenarios.
3. Instead of analyzing past (well-known) stress scenarios, one may also run new types of hypothetical scenarios to highlight the weaknesses and vulnerability of the bank portfolio. Such bank-specific scenarios are tailored to the portfolio of the bank. Their advantage is that they are not limited to past stress events. On the other hand, it can be difficult to think of all possible scenarios that highlight the main weaknesses of the bank (e.g., due to model mismatch).

Stress testing is most often used to capture the most important risks of the banks. Popular scenarios are related to equity risk, interest rate risk and

emerging markets. The 1987 stock market crash, or a corresponding hypothetical stock market crash is the most often used stress test. More details on commonly used stress test scenarios can be found in the CGFS census report [118].

Sensitivity stress tests report the impact on the portfolio value as a result of one or more pre-defined moves in one specific risk factor (or a small number of closely related risk factors). The risk factor moves typically consist of symmetric shocks, while scenario stress tests typically consist of asymmetric shocks. The sensitivity tests typically measure the impact of a single risk factor, which makes them simpler to perform, but less attractive as a complementary tool for other risk measurement tools like VaR. Sensitivity tests are therefore considered as less important than scenario tests by some banks, but are performed more frequently because of their simplicity. The most commonly used sensitivity stress test in the CGFS census report [118] was a parallel yield-curve shift, which is closely related to duration, the oldest and most basic measure of interest rate risk.

Whatever type of stress testing is performed, the stress tests are performed regularly and reported to the senior management and the board of directors. Typically, the stress test results are examined by a high-level risk committee. When necessary, preventive and corrective actions have to be taken by reducing or hedging the position. The CGFS census report [118] indicates that stress test results are also used to set limits and even cause positions to be unwound. Such decisions, however, are almost never taken automatically, but are made after a more detailed case-by-base analysis.

#### 6.3.2.4 Backtesting

A cornerstone of the internal model approach (IMA) is the backtesting framework. An internal model defines a VaR. When the VaR of the internal model is too low compared to that *ex post*, the regulators will apply a penalty factor as illustrated in Table 6.17.

The quality of a market risk model is measured by counting the number of exceptions. An exception occurs when the internal losses breach the VaR limit defined internally by the bank. The number of exceptions is counted on a yearly basis. Note that market risk observations are available on a daily basis, which makes it easier to evaluate a model. The penalty zones are defined by the Basel Committee on Banking Supervision by making a trade-off between type-I and type-II errors:

**Type-I error:** A correct model is rejected due to bad luck.

**Type-II error:** A wrong model is not rejected due to bad luck.

**Table 6.17** The Basel penalty zones. Up to 4 exceptions on a yearly basis is acceptable. For a higher number of exceptions, the result falls in the yellow and red zones where progressively an increased penalty factor  $k$  is applied [45]. A red zone implies a mandatory market risk charge increase from eqn 6.17.

Zone	Number of exceptions	Potential increase in $k$
Green	0	0.00
Green	1	0.00
Green	2	0.00
Green	3	0.00
Green	4	0.00
Yellow	5	0.40
Yellow	6	0.50
Yellow	7	0.65
Yellow	8	0.75
Yellow	9	0.85
Red	$\geq 10$	1.00

The trade-off between type-I and type-II errors results in the penalty zones of Table 6.17. The result of the backtest is reported in terms of traffic lights. When the model is in the yellow zone, the national supervisor may decide to apply the penalty factor depending on the causes for the model malfunctioning. When the model is in the red zone, a penalty factor is mandatory [45]. The corresponding add-on to the multiplicative factor  $k$  in eqn 6.17 is reported in Table 6.17.

### 6.3.3 Operational risk (pillar 1)

Operational risk is the third part of the pillar 1 minimum capital requirements as depicted in Fig. 6.2. Operational risk is defined in Chapter 1 as the risk resulting from inadequate or failed internal processes, people and systems, or from external events. It includes legal risk, but excludes strategic and reputation risk. The different fields of operational risk include internal and external fraud, employment practices and workplace safety, clients, products and business practices, damage to physical assets, business disruption and system failures and execution, delivery and process management. Operational risk is a new element in the Basel II Capital Accord, before it was implicitly included in the 8% capital ratio.

The new capital accord outlines three methods for calculating operational risk capital charges with increasing sophistication and risk sensitivity

(Table 6.3): the basic indicator approach (BIA), the standardized approach (SA) and the advanced measurement approach (AMA). These approaches are summarized below. Also for operational risk, partial use is allowed during the roll-out plan or on a permanent basis in specific cases. Detailed information is available from [55, 63].

### 6.3.3.1 Basic indicator approach (BIA)

The capital requirement  $K_{\text{BIA}}$  for operational risk is a fixed percentage ( $\alpha$ ) of the average annual gross income (GI) over the last 3 years:

$$K_{\text{BIA}} = \alpha \times \sum_{i=1}^N \frac{\text{GI}_i}{N}.$$

In the case of a positive GI, the average is calculated over the last 3 years ( $N = 3$ ). Years with negative GI are excluded from the average and both numerator and denominator are adjusted, e.g.,  $n = 2$  in the case of one negative GI over the last 3 years. Supervisors may review the capital requirement, e.g., from comparison with peer groups under pillar 2.

The gross income is defined as the net interest income plus the net non-interest income. It is gross of provisions, operating expenses and service provider fees. Realized profits/losses from the sale of banking book securities, extraordinary items and insurance income are excluded as well (see section 650 [63]). The percentage is put at  $\alpha = 15\%$ .

### 6.3.3.2 Standardized approach (SA)

The standardized approach (SA) provides a more refined capital requirement. Different business lines face different types of operational risk. The risk of the different business types is listed in Table 6.18. Per year, the gross income of the bank is split into the gross income of the 8 business lines. Business lines may have negative gross income. When the bank's gross income is negative, the year is not counted in pillar 1, but the overall operational risk capital charge is subject to supervisory review under pillar 2.

The SA capital charge  $K_{\text{SA}}$  for operational risk is obtained as

$$K_{\text{SA}} = \frac{1}{3} \sum_{i=1}^3 \max \left( \sum_{j=1}^8 \text{GI}_j \times \beta_j; 0 \right),$$



**Table 6.18** Operational risk capital charge percentages  $\beta$  per business line activity.

Business lines	Beta	Percentage
Firm finance	$\beta_1$	18%
Trading and sales	$\beta_2$	18%
Retail banking	$\beta_3$	12%
Commercial banking	$\beta_4$	15%
Payment and settlement	$\beta_5$	18%
Agency services	$\beta_6$	15%
Asset management	$\beta_7$	12%
Retail brokerage	$\beta_8$	12%

where  $GI_j$  is the gross income of business line  $j$  and  $\beta_j$  ranges from 12% to 18% as indicated in Table 6.18.

Note that there also exists an alternative standardized approach (ASA) in which the operational risk charge for retail banking and commercial banking depends on the total outstanding exposure and advances. National supervisors may allow banks to apply the ASA instead of the SA.

The standardized approach is subject to qualifying criteria. As sufficient capital is not considered as the single determinant of a good risk management, it is required that the board of directors and senior management are actively involved in operational risk management. The operational risk management system has to be conceptually sound and implemented with integrity. The bank has to put in place sufficient resources in the business lines as well as for internal control and audit. The mapping approach for the gross income to the business lines has to be documented and in line with Annex 8 of [63]. Regulators may insist on a period of initial monitoring before applying it for regulatory capital calculations. International banks are subject to more criteria specified in section 663 of [63] concerning independent design, internal evaluation, audit, validation, documentation, reporting and external supervision and audit.

### 6.3.3.3 Advanced measurement approach (AMA)

Banks are allowed to apply internal risk measurement techniques for operational risk. These approaches are subject to supervisory review. Such approaches typically estimate the shape of the loss distribution for operational risk. In the actuarial approach, the loss distribution is fitted on

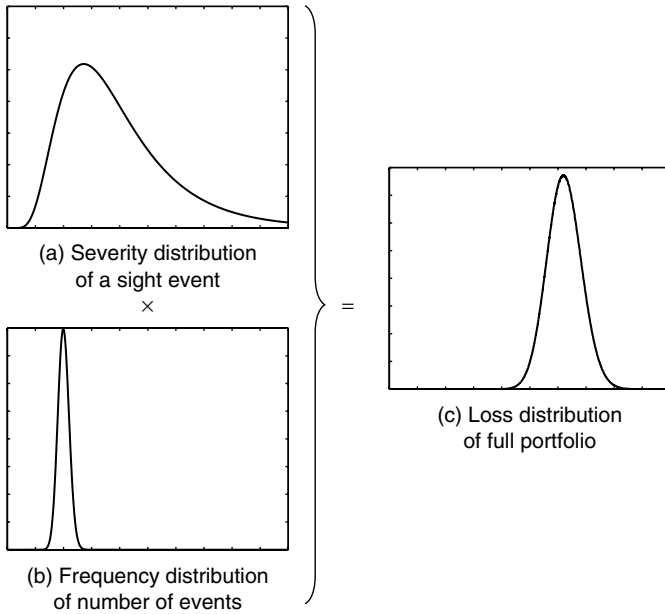

**Fig. 6.7** Probability density functions in the advanced measurement approach for operational risk. The loss severity distribution of each event is depicted top left, the number of events is reported bottom left and the resulting loss distribution of the bank or insured portfolio is depicted on the right.

internal/external data and is driven by two elements:

1. The number of events per year depends on the type of activity: one identifies the loss frequency distribution, e.g., by using a Poisson distribution (Fig. 6.7b).
2. The loss severity of an event depends on the type of activity: one identifies the loss severity distribution, e.g., a log-normal or extremal event distribution (Fig. 6.7a).

The total loss distribution is obtained from the convolution of both distributions (Fig. 6.7(c)). The parameters of the frequency and severity distribution depend upon the business-line characteristics, environment, . . . For example in a retail environment, the number of events is expected to be larger than in a firm environment, but losses tend to be larger. The bank's calculation approach has to be sufficiently refined to have an adequate capital requirement. The statistical estimation of the loss distribution is hampered by data-scaling and data-censoring issues, like, e.g., a materiality floor below which no events are reported. The literature on operational risk has recently gained importance [5, 6, 126, 307, 483].

The bank's capital charge is put at the 99.9% VaR of the operational risk loss distribution. It includes both expected and unexpected loss, unless the bank can show to its regulator that the expected loss amount is taken already into account in its business practices. The use of the AMA is subject to the same qualitative and quantitative criteria of the SA. Additional requirements concern internal data collection, pooling/benchmarking with external data and scenario analysis of extremely high loss events. Environmental factors and internal operational risk factors that may impact the operational risk profile need to be taken into account as well. Risk mitigation is allowed up to 20% of the AMA capital charge.

#### **6.4 Pillar 2 (supervisory review process)**

Whereas pillar 1 focuses on quantitative risk measurement, pillar 2 emphasizes the need for a qualitative approach to bank supervision (Fig. 6.2). This pillar provides rules for the supervisory review of a bank's capital adequacy and internal risk assessment processes. On the one hand, its goal is to ensure that banks have adequate capital to support all the risks (credit risk, market risk, operational risk, banking book interest rate risk, liquidity risk, reputation risk, business risk, . . .); on the other hand, it aims at encouraging banks to continuously improve internal procedures to measure, monitor and manage their risks. Pillar 2 stimulates an ongoing adjustment and refinement of new methods of risk management and internal control. Sound capital adequacy not only requires sufficient capital, but also strong risk management with sound risk measurement, internal control, application of internal limits and risk mitigation.

The pillar 2 supervisory review process consists of internal bank review and external review by the regulator as illustrated in Fig. 6.8. Essentially, banks are required to analyze all their risks – not only those of pillar 1 – and verify whether they are sufficiently capitalized. Apart from credit, market and operational risk, the minimum risks that need to be covered are interest rate risk in the banking book, liquidity risk, reputation and strategic risk. Because such exercises are still developing,<sup>92</sup> the pillar 2 text is rather

<sup>92</sup> Note that economic capital models are a recent technique that are adopted only recently by the largest financial institutions. There does not yet exist an industry standard that is implemented by the majority of banks.

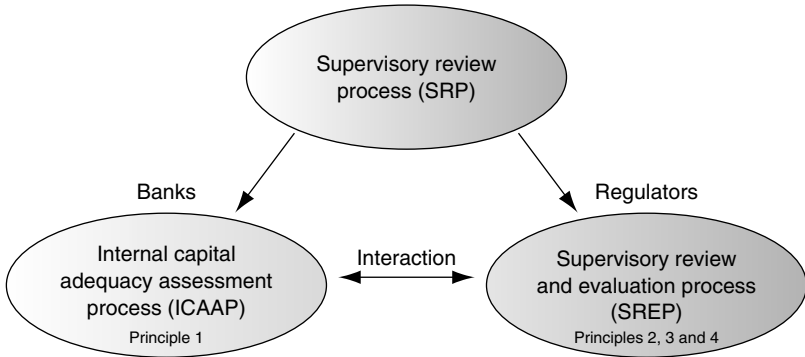

**Fig. 6.8** The supervisory review process (SRP) consists of the internal capital adequacy assessment process (ICAAP) and the supervisory review and evaluation process (SREP). For the ICAAP, the bank has to ensure it has sufficient capital and efficient methods to measure and manage its risks. The supervisory review and evaluation process overviews the ICAAP and defines regulatory intervention to ensure sufficient capitalization. The SRP is defined by four key principles summarized in Table 6.19.

vague and far from explicit. Although pillar 2 is an important element of Basel II that will require a lot of effort from banks and local supervisors, only a coarse description is available in the ICCMCS [63]. Market participants argue that there does not yet exist an industry standard for the pillar 2 requirements and that supervisors will rather evaluate *ex post* the bank's work instead of describing *ex-ante* precise guidelines. Hence, regulators will evaluate the bank's exercises and determine the amount of capital required in excess of pillar 1 to capture the additional risks. However, this uncertainty has caused many industry remarks and requests for further guidance. The industry was also concerned that differences between interpretations of national regulators on pillar 2 may disrupt the targeted level playing field.

The supervisory review process is specified by means of the 4 key principles summarized in Table 6.19. The first principle describes the internal capital adequacy assessment process (ICAAP) that defines the duty of the bank to have sufficient capital to cover all its risks and the responsibility of the bank to have efficient methods to measure and manage capital requirements and risk. The principles 2, 3 and 4 define the role of the regulator to review and evaluate the bank's ICAAP and to take actions when necessary [47]. The ICAAP is not prescribed by the supervisors.

**Table 6.19** The 4 key principles of pillar 2. The first principle describes the internal capital adequacy process (ICAAP), while the other principles describe the supervisory review and evaluation process (SREP).

---

**Principle 1:** Banks should have a process for assessing their overall capital adequacy in relation to their risk profile and a strategy for maintaining their capital levels.

**Principle 2:** Supervisors should review and evaluate banks' internal capital adequacy assessments and strategies, as well as their ability to monitor and ensure compliance with regulatory capital ratios. Supervisors should take appropriate supervisory action if they are not satisfied with the result of this process.

**Principle 3:** Supervisors should expect banks to operate above the minimum regulatory capital ratios and should have the ability to require banks to hold capital in excess of the minimum.

**Principle 4:** Supervisors should seek to intervene at an early stage to prevent capital from falling below the minimum levels required to support the risk characteristics of a particular bank and should require rapid remedial action if capital is not maintained or restored.

---

Specific to the supervisory review process is that it aims to cover external factors like cyclical effects together with risk factors that are not taken into account under pillar 1 like the (non-)diversification effects and concentration risk, interest rate risk in the banking book, and uncertainties in measuring operational risks.

The supervisory review process needs to ensure that banks have put in place a framework for assessing their capital in relation to their risks, that banks operate above the minimum capital ratios and that corrective action is taken when needed. National supervisors will be responsible for evaluating and ensuring that banks have sound internal processes in place that will enable them to take care of all existing and potential risks and capital-adequacy requirements. In this context, it is crucial to achieve an important harmonization on the major rules to compute the minimum capital required, but also of prudential practices imposed by local regulators so as to create a level playing field for internationally active banks. The four principles are described in detail below.

#### 6.4.1 Principle 1

The bank management bears the primary responsibility for the capital adequacy. The bank has to be able to demonstrate that its capital targets are well

founded and in line with the bank's risk profile given the current operating environment. The capital adequacy needs to be consistent with the current risk profile, but also needs to evolve together with the future risk profile. Rigorous stress testing is considered as a key tool to identify possible future events that could adversely impact the bank.

The supervisory review process aims to ensure that the internal bank risk assessments and capital estimates are commensurate with the nature and complexity of the bank's activities and corresponding risks. The Basel II guidelines do not propose a blueprint of an internal capital adequacy assessment process (ICAAP), but provide a number of elements to indicate what is expected from the ICAAP. The following are the five features of a sound assessment process.

**Board and senior management oversight:** It is recognized that a sound risk management process is the foundation for an effective assessment of the bank's capital adequacy. The bank's management is responsible for understanding the nature and level of risks being taken, and their relations with adequate capital levels. A key task of the management is the design, implementation and support of an integrated strategic plan that aligns asset deployment, capital planning, funding sources, management, marketing, operations and information systems. The board has to ensure that the management communicates the strategic plan, firm goals and risk tolerance clearly throughout the organization. The board also has to ensure that a rigorous risk measurement system is established relating risk to capital levels. Internal procedures are defined in policies and effective internal control monitors compliance with these policies.

**Sound capital assessment:** The formality and complexity of a sound capital assessment process depends on the size and complexity of the banks' activities and risk exposures. Fundamental elements of a sound ICAAP include:

1. Written policies and procedures that identify, measure and report the risks,
2. A process that relates capital to the risk level,
3. A process that states capital adequacy goals with respect to risk, taking into account the firm goals of the strategic plan,
4. A process of internal controls, reviews and audit to ensure the integrity of the overall management process.

**Comprehensive assessment of risks:** All material risks the bank is exposed to should be addressed in the ICAAP. As not all risks can be measured accurately, at least a measurement process should be established. The risk exposures the bank needs to consider include credit risk, market risk, banking book interest rate risk, liquidity risk and other risks like operational, strategic and reputation risk.

For credit risk, the ICAAP of sophisticated banks should at least cover risk rating systems, portfolio analysis, securitization/complex derivatives, and large exposures/risk concentrations. The internal risk rating systems have to cover all exposures and not only distressed counterparts. Loan loss reserves are taken into consideration in the ICAAP. At the portfolio level, portfolio weaknesses, concentration and correlation effects and the risks due to securitization and complex credit derivatives are key attention points. Furthermore, the analysis of counterpart credit risk should include consideration of public evaluation of the supervisor's compliance with the core principles of effective banking supervision [47].

For market risk, the assessment is based on the bank's internal value-at-risk measure and the results of stress tests.

For interest rate risk in the banking book, the ICAAP has to include all material interest rate positions and all relevant repricing and maturity data. The accuracy of the risk measurement depends heavily on the data quality and on the assumptions of the model. Therefore, the management should give special attention to the data quality and model assumptions. See [53] for more details. Observe that interest rate risk is not taken into account in the pillar 1 capital calculation.

For liquidity risk, banks must have adequate systems to measure, monitor and control liquidity risk as detailed in [51]. Liquidity is a crucial element for the viability of the bank and adequate capital levels are needed to avoid liquidity problems, especially in crisis situations. An example of a liquidity stress scenario is an idiosyncratic downgrade of the bank's rating with 3 notches and the corresponding impact in terms of funding, withdrawal of savings accounts, etc.

Reputation risk is the risk that earnings and capital will be adversely impacted because of an adverse image and perception of the financial institution by customers, counterparts, shareholders, investors and/or regulators. Examples are tax and legal risks. Strategic risk is the risk on earnings and capital due to changes in the business

environment, from adverse business decisions and lack of responsiveness of the organization to changing business environments. The BCBS expects banks to develop techniques to measure reputation and strategic risk.

**Monitoring and reporting:** Banks should establish an adequate system for monitoring and reporting risk exposures and the impact of risk profile changes on capital levels. The risk management has to be organized such that the risk profile and capital needs are regularly reported to senior management and board of directors. The frequency of reporting depends, a.o., on the risk types, levels and changes. The reports should allow senior management to

1. Evaluate the level and trend of all material risks and their impact on capital levels,
2. Evaluate the sensitivity and reasonableness of the key assumptions in the ICAAP,
3. Determine that sufficient capital is held against the various risks and that the capital levels are compliant with the established capital levels of the strategic plan,
4. Assess the future capital requirements and make adjustments to the bank's strategic plan, if necessary.

**Internal control review:** Effective internal control is essential to the ICAAP. It comprises independent review and, where appropriate, internal and external audit. The board not only has the responsibility to ensure effective risk measurement, but also to establish a method for monitoring compliance with internal policies. The board should regularly review the efficiency of its internal control system to ensure that the business practices are consistent with the bank's policies and strategy. The internal control is concerned with

1. The appropriateness of the bank's capital assessment process given the nature, scope, size and complexity of its activities,
2. Identification of large exposures and risk concentrations,
3. Accuracy and completeness of data inputs into the bank's assessment process,
4. Reasonableness and validity of scenarios used in the assessment process,
5. Stress testing and analysis of assumptions and inputs.



Note that the requirement that every bank should have an ICAAP also holds for banks that choose the standardized approach or the foundation/advanced internal ratings based approach. Banks choosing a rather simple approach under pillar 1 may, nevertheless, face important efforts under pillar 2.

It is also useful to know that the CEBS defined 10 principles<sup>93</sup> for the ICAAP.

### **6.4.2 Principle 2**

Supervisors should regularly review and evaluate the bank's internal capital adequacy assessment process (ICAAP), the risk position of the bank, the resulting capital levels and the quality of capital held. The supervisors should also evaluate the quality of the bank's ICAAP without replacing the actual bank's risk management. The periodic review may consist of onsite inspections, offsite review, discussions with bank management, review of work done by external auditors and periodic reporting. As errors and wrong assumptions in the risk methodology and scenario analysis have a strong impact on the estimated capital requirements, intensive and indepth reviews are required.

The review process consists of a supervisory assessment of the adequacy of the internal capital levels and aims at covering the full range of material risks the bank is exposed to. Apart from the capital adequacy, capital calculations and stress-test-scenario analyses, supervisors also test whether the bank effectively uses the internal risk estimates, e.g., for limits setting, business-line performance, price setting, provisioning, risk control, economic capital calculation. Banks have to pass the use test: when the bank's figures used for regulatory capital are consistently applied with success in other domains related or non-related to Basel II (limit setting, RAROC, credit approval, . . .), this provides a qualitative proof that these figures are correct. Wrong figures will be noted earlier when the figures are used effectively at different places and not only for regulatory purposes. Later in the qualitative aspect, the supervisors will also pay attention to the quality of the bank's management information systems, risk reporting, management and control.

<sup>93</sup> These 10 key principles are 1. requirement for every institution; 2. responsibility of the institution; 3. documented and management responsibility; 4. integral part of management and decision process; 5. regularly review; 6. risk based; 7. comprehensive; 8. forward looking; 9. adequate measurement and management; and 10. reasonable outcome.

In general, the capital levels should be sufficient to cover the bank's risks given its risk management process and should be able to absorb unexpected events as can be measured by stress testing. As a result of the review process, the regulator has to be able to determine whether

1. The target levels of the capital chosen are comprehensive and relevant to the current operating environment;
2. The levels are monitored and reviewed by senior management appropriately;
3. The capital composition is appropriate for the nature and scale of the bank's business.

Complementary to the capital adequacy review, the supervisors must also review compliance criteria concerning risk management standards and disclosure for certain internal methodologies, e.g., credit risk mitigation and asset securitization. Supervisors must ensure that minimum standards derived from industry are applied. In particular, when instruments and methodologies are used that can reduce pillar 1 capital requirements, these should be sound, carefully tested, documented and reviewed.

When the regulators are not satisfied with the results of the internal risk assessment and resulting capital levels, supervisors should consider a range of actions defined under principles 3 and 4.

### **6.4.3 Principle 3**

According to principle 1, the responsibility of capital adequacy is a key task of the bank management, subject to regulatory supervision. Principle 3 states that supervisors are able to require or encourage banks to hold excess capital to operate above minimum pillar 1 capital requirements. Generally, local supervisors in member countries expect banks to operate above minimal capital ratios and to hold an additional buffer.

Banks may have several motivations to operate above minimal capital levels. Typically, the minimum capital requirements correspond to a BBB-rated bank. Most international banks see better capital ratios as a way to achieve higher external ratings that give competitive advantages. Changes in the business, the risk types and the volumes may induce fluctuations into the resulting capital ratio, such that it is desirable to keep a buffer. Additional capital raising can be costly, especially in economic downturn or distressed situations. It is a serious flaw for banks to fall below minimum regulatory capital requirements, which may trigger a whole series

of events like non-discretionary corrective action and reputation damage. Banks may also operate above the pillar 1 capital to have an additional buffer for risk not taken into account in pillar 1 (e.g., concentration or interest rate risk).

The excess capital depends on the adequacy of the credit, market and operational (and possibly other) risk departments. Indeed, not only capital but also a strong risk management determines the overall bank risk as discussed in Chapter 1. Furthermore, the excess capital also depends on the accuracy and volatility of their pillar 1 input measurements. Supervisors can require stronger risk management processes and risk control in case of serious inadequacies of the bank's risk management. It is preferred to cure such situations by improving the risk management processes instead of additional capital. Regulators can also impose target capital ratios or require weakly capitalized banks to raise their capital ratios. The Basel II document mentions 3 non-mutually exclusive approaches to ensure that banks operate with adequate capital levels:

**Reliance on a bank's internal capital assessment:** If the supervisor determines that the bank has a sound and well-developed internal capital assessment process, the supervisor may rely on the bank's internal judgments.

**Establishment of trigger and target ratios:** The supervisor can determine a target capital ratio corresponding to the bank's individual risk profile. It can also communicate trigger ratios that serve as a minimum capital ratio. Supervisory corrective action is triggered when capital ratios fall below this level.

**Establishment of defined capital categories above min. ratios:** The supervisory authority can provide well-defined and well-documented capital standards defining, e.g., adequately capitalized and well-capitalized bank standards for certain capital categories. The supervisor can make these rules applicable to all banks in its jurisdiction.

#### 6.4.4 Principle 4

When supervisors become concerned that a bank fails to meet the requirements of principles 1–3, the BCBS expects some kind of supervisory response. The same holds when there is a significant risk that the bank fails these requirements in the near future.

The guidance documents that are listed at the end of pillar 2, enumerate some actions supervisors could take in the case of distressed situations:

1. increased monitoring of the bank,
2. requiring improvements in the controls environment in the bank, in terms of systems and/or personnel,
3. requiring the bank to prepare and implement improved risk assessment and capital-allocation procedures,
4. requiring the bank to hold capital in excess of the pillar 1 minimum,
5. requiring the bank to prepare and implement a satisfactory capital restoration plan via, e.g., capital raise, restricted asset growth, asset reduction, withdrawal from certain lines of business and divestiture of certain subsidiaries,
6. restriction of payment of dividends and/or executive bonuses,
7. requiring the bank to raise additional capital immediately,
8. requiring that senior management and/or the board be replaced.

The type of response should depend on the causes and severity of the stressed situation. The supervisor should expect timely response and resolution of their concerns, otherwise the supervisor is expected to turn to the more prescriptive actions listed above.

### **6.4.5 Specific attention points**

Some key risks that are not directly addressed under pillar 1 receive specific attention in the pillar 2 supervisory review process.

#### **6.4.5.1 Interest rate risk in the banking book (pillar 2)**

For the Basel Committee, interest rate risk in the banking book remains a potentially significant risk for which capital support is required. Discussions with banks revealed that the treatment of this risk is very heterogeneous, which makes a generic formula like the credit risk weights rather difficult. Therefore, the capital assessment for interest rate risk is treated in pillar 2.

Supervisors may identify mandatory minimum capital formulae for homogeneous banking activities, but the Basel Committee considers the bank's internal rating systems as the principal tool for the measurement and management of banking book interest rate risk. These practices are supervised by regulators, e.g., by means of simple techniques like a standard interest rate shock of 2%. Banks whose value reduces by more than 20% of Tier 1 and Tier 2 capital are considered as especially vulnerable and require specific regulatory attention. An overview of supervisory review for banking book interest rate risk has been given in [59].

### 6.4.5.2 Credit risk (pillar 2)

A number of specific issues for credit risk is explicitly discussed in section 765–777 [63]:

**Stress tests under the IRB approaches:** For pillar 1, stress tests are additionally required on top of the minimum capital resulting from the risk weight formula. The stress techniques and results are part of the supervisory review process. Stress testing is discussed in book III.

**Default definition:** The Basel II default definition (section 4.4.1.1) is a cornerstone of coherent risk measurement amongst banks. Supervisors must review the interpretation of the regulatory default definition in their jurisdictions.

**Residual risk:** Although collateral and other risk mitigants reduce credit risk, there remains a residual risk, e.g., because of the inability to seize (timely) pledged collateral, the refusal/delay of payments of guarantors, or ineffective untested documentation. Supervisors will require that banks master, manage and control the residual risk of credit risk mitigants effectively. The management, appropriateness, operation, policies and procedures are reviewed regularly by supervisors.

**Concentration risk:** Concentration risk occurs when the bank is exposed to a single exposure or a group of (highly correlated) exposures that may result in a high loss that would threaten the bank's health or operational continuity. From Chapter 5, the importance of credit concentration and correlation on the loss distribution is clear. Concentration risk is recognized as the single most important cause of problems for banks (section 770 of [63]).

Credit concentrations are not only due to single large exposures, but can occur at the asset or liability side; on-and off-balance. When considering concentration, it is also important to take into account correlation effects, e.g., contagion or spill-over effects may cause the distress of a single important counterpart resulting in the financial distress of a large number of counterparts. Risk concentration may occur for various reasons, a.o.,

1. Important exposures to a single counterpart or a group of counterparts (e.g., mother and several daughter companies). Local regulators typically impose concentration limits for these types of exposure. Limit setting is a key tool of bank risk management.
2. The bank's specialization towards a certain economic sector (e.g., agriculture or a specific local industry sector) may result in high losses

when the sector witnesses severe difficulties (e.g., cattle epidemics for agriculture or a regional sector crisis with several firms defaulting in the region the bank is active in).

3. An exposure to a large firm and many subcontracting companies may appear to have low correlation. A default of one subcontracting company may not result in an important loss, but with the default of the large firm a large number of smaller companies may lose their primary customer and face financial difficulties. In addition, many employees may lose their job and find it more difficult to pay the mortgage.
4. Indirect exposures from credit risk mitigation techniques, e.g., exposure to a same amount of one collateral type or the same guarantor.

Credit risk concentrations should be part of the bank's stress testing program, as explained in book III.

Banks are recommended to comply with the "Principles for the Management of Credit Risk" [50]:

**Counterparty credit risk:** Counterparty credit risk (CCR) is the risk that the counterparty to a transaction could default before the final settlement of the transaction's cash flows, as discussed in section 4.4.3.3. An economic loss would occur if the transactions or portfolio of transactions with the counterparty have a positive economic value at the time of default. This type of risk due to various transaction types is discussed in Annex 4 of [63]. This type of risk is part of the supervisory review process. The above requirements, a.o., stress testing, are also applicable to this risk.

**Securitization:** Specific guidelines need to ensure that the fast developments in the domain of securitization do not result in inadequate capital charges as a result from pillar 1 rules. Therefore, the specific attention points for securitization have been defined in section 784–807 to verify capital requirement under pillar 2. These attention points include:

**Significance of risk transfer:** Securitization type of transactions may be carried out for other reasons (e.g., funding). When a securitization transaction results in lower capital requirements, the risk transfer needs to be significant.

**Market innovations:** When new securitization features would unbalance the capital requirements of pillar 1, regulators are expected to take appropriate action under pillar 2.

**Provision of implicit support:** When the bank provides support to a securitization transaction, the risk is not fully transferred. Support can

either be contractual or implicit. Contractual support is clearly documented and covers, a.o., overcollateralization and credit derivatives. A bank provides implicit support, e.g., when it repurchases assets with deteriorated credit quality. In such cases, the risk is not fully transferred and the capital requirements need to be adjusted.

**Call provisions:** Banks may call the securitization transaction prematurely under certain circumstances, e.g., for cost-efficiency reasons (clean-up calls when the amount of remaining assets is too small). Such a call may also negatively impact the bank's capitalization because of the low credit quality of the remaining assets. Supervisors may examine, prior to the call, the motivation for the call and the impact on the bank's capitalization.

**Early amortization:** Some structured products like Danish mortgage bonds<sup>94</sup> may be subject to the risk of early amortization. This risk is also present when the underlying assets are revolving credit facilities. Such products involve, a.o., credit and interest rate risk that requires specific measurement and management techniques. These products may also involve higher risk and capital charges. Supervisors have the duty to review these elements.

### 6.4.5.3 Market risk (pillar 2)

The specific attention points for market risk are:

**Policies and procedures for trading book eligibility:** Exposures are treated differently depending on whether they are booked on the trading or banking book. To avoid regulatory arbitrage, the bank must have clear policies, that comply with section 684–689 [63], to delineate the trading and banking book activity. The supervisor needs to review the policies and the bank's practice.

**Valuation:** The valuation policies and procedures for market risk capital adequacy should be sufficiently prudent, especially for less liquid products or high concentrations. These products may be less easy to sell (at the expected price) in adverse market conditions. Banks should hold additional capital for such effects.

<sup>94</sup> In the case of Danish mortgage bonds the house-owner can make early pre-payments (without penalties). This pre-payment risk depends mainly on interest rate evolutions. When interest rates decline, the house-owner may decide to make an early repayment and refinance the mortgage at a lower interest rate.

**Stress testing under the internal models approach:** In addition to the minimum capital requirements for market risk, banks should perform stress testing to assess their capital requirements. The stress-test assumptions and results are reviewed by the regulators.

**Specific risk modelling under the internal models approach:** The supervisors need to review that banks comply with additional criteria defined in the market risk amendment when banks opt to model specific risk. Attention points include liquidity of positions and/or positions with limited price transparency. When the bank's approach is judged to be inadequate, the standardized specific risk charges will be required.

#### 6.4.5.4 Operational risk (pillar 2)

The supervisory review process has to focus particularly on the applicability of the basic indicator approach and standardized approaches for operational risk. The local supervisor needs to verify the applicability of the gross income multiplier in pillar 1. The supervisor can use benchmarking across banks to check whether the resulting capital covers the operational risk requirements for the size and activity types of the banks. Guidance for the management and supervision of operational risk is provided in [55].

#### 6.4.6 Other aspects

Although the Basel II guidelines provide a detailed framework for regulatory supervision, discretionary elements remain inevitable. In order to create a level playing field, the supervisors are requested to carry their obligations in a transparent and accountable manner to the extent possible.

Supervisors are encouraged to take part in cross-border communications and co-operations. Such cross-border communication and co-operation is important for the supervision of large and complex international banking groups.

The pillar 2 description is concluded with an extensive list of guidance reports for the supervisory review process. These documents cover specific risk aspects (credit, derivatives, operational, liquidity, interest rate risk, . . .) as well as firm governance, audit and supervisory guidance for weak banks.

### 6.5 Pillar 3 (market discipline)

The goal of pillar 3 compared to the other two pillars, has required far less effort from banks so far, from which it also got the name "forgotten pillar".



Pillar 3 serves to catalyze prudential risk management by market mechanisms (Fig. 6.2) and corresponds to mainly reporting and disclosure. Enhanced disclosure of the risk profile and capitalization to financial markets are a key element in the new capital accord. It is assumed that well-informed market participants reward a prudential risk management strategy and effective risk control, while, vice versa, riskier banks will be penalized. This provides an incentive for banks, and financial institutions in general, to monitor and efficiently manage their risks.

Pillar 3 recognizes that market discipline has this potential to reinforce capital regulation and other supervisory efforts to promote the safety of banks and the financial system in general. The BCBS believes that supervisors have a strong interest in facilitating effective market discipline as a lever to strengthen the safety and soundness of the banking system [52].

The framework is sufficiently flexible to achieve the market discipline and to meet the concerns of the credit institutions by the protection of confidential information. In addition, national regulators will decide which information is aimed at the supervisors and which information will be disclosed to the markets.

In this summary, first general elements are discussed in 6.5.1. Details on the disclosures of the scope of Basel II, the bank's capital and the risk exposures and their assessment are discussed in sections 6.5.2.2, 6.5.2.3 and 6.5.2.4. The scope of the application, bank capital, and Basel II risk exposures for pillars 1 and 2 have been discussed from a bank risk perspective in sections 6.1, 6.2, 6.3 and 6.4, respectively. In the next sections, the disclosure requirements are discussed. Regulators will determine which part of the disclosure requirements will be made public and which part will be only addressed to supervisory bodies.

### **6.5.1 General considerations**

The purpose of pillar 3 is to complement pillar 1 (minimal capital requirements) and pillar 2 (supervisory review process). Market discipline is catalyzed by a set of disclosure recommendations developed by the BCBS. The disclosure will allow market participants to assess important information on the capital, risk exposure, assessment processes, and capital adequacy of the bank in general. The disclosure should be consistent with the information the senior management and management board uses to manage the risks of the bank. In general, it is expected that the expected costs of the enhanced disclosure are low as the banks should have already collected this

information for the internal risk assessment process. These costs and additional drawbacks concerning publication of key proprietary information are outweighed by the benefits of enhanced bank transparency. A number of costs and benefits of disclosure are discussed in [48, 63]. The committee recognizes that the differences in capital structure, in risk exposure and in banks' reliance on capital markets may result in different impacts of market discipline. However, no internationally active bank could expect to insulate itself entirely from the judgments of the markets.

Although there exists a good rationale to implement pillar 3, in practice, it remains the legal authority of the banking supervisors to set disclosure standards. This authority varies across countries. In some countries, supervisors can implement disclosure requirements via binding regulations, in others one can only use indirect approaches like the definition of sound practice recommendations. The Committee intends to introduce "strong recommendations" or "principles" to implement pillar 3. The disclosure recommendations are strengthened by explicit formal disclosure policies approved by the bank management, the supervisory assessment of the accuracy of the disclosed information and conformity of supervisory requirements with accounting standards, e.g., IAS 30. In the case of non-disclosure, the committee expects effective intervention from local supervisors to achieve appropriate disclosure. This intervention should depend on the severity of non-compliance and can range from moral persuasion to reprimands, sanctions and financial penalties. Direct sanctions can be taken, e.g., when no disclosure is given concerning internal rating methodologies that allow lowering of the risk weights. In such cases, the acceptance of the methodology can be subject to qualifying criteria including disclosure requirements and the supervisor can defer the use of the internal-ratings-based approach until the disclosures are compliant with the Basel II accord [63].

The characteristics of the disclosures made by the banks should be consistent with the general criteria described in [48]. These criteria on enhanced bank transparency are concerned with:

**Interaction with accounting disclosures:** The final release of the Basel II Capital Accord explicitly mentions that pillar 3 does not conflict with accountancy standards. Pillar 3 is limited in scope, while accountancy standards have a broader scope. The intention of ongoing relationship with the accounting authorities is made to follow up industry and accounting developments and to consider consistent updates of pillar 3. The interaction of pillar 3 with accounting disclosure is important as regulatory

disclosures could be partially made under accounting requirements or to fulfill stock-listing requirements. Of course, material differences between regulatory disclosure and accounting or other disclosure should be carefully explained. It is up to the bank management to decide the medium and location of the disclosures. An advantage of accounting and other disclosures is that the information is generally subject to audit and strong control requirements. The management should ensure that a thorough internal validation process exists for supplementary regulatory disclosures.

**Materiality:** Materiality is a key decision driver when considering whether to disclose information or not. While one could define proportional or absolute materiality thresholds, such an approach remains artificial and may not apply to all situations. The Basel Committee on Banking Supervision considers that information is material if its omission or misstatement could impact the assessment or decision of a “user” relying on that information.

**Proprietary and confidential information:** The concern of protection of proprietary information was expressed by several respondents during the consultation process that took place before finalizing the Basel II accord. Too detailed disclosure on customers, products, methodologies or systems may weaken the competitive position of some banks, while on the other hand disclosure is necessary for the operation of pillar 3. The Basel Committee of Banking Supervision believes that the current recommendations and requirements keep the balance between the operational requirements and protection of proprietary information.

**Frequency:** The periodical disclosure should be made on a semiannual basis so as to give good information on the current risk profile. The disclosure could be made using annual and half-yearly reports or using electronic media. Some disclosure categories that may exhibit important fluctuations on shorter time intervals, like, e.g., risk exposure for internationally active commercial banks, are expected to be reported on a quarterly basis. At a minimum level, these banks should provide quarterly disclosures of Tier 1 and total capital adequacy ratios and their components at a quarterly basis. For important credit or market events, general material changes could be disclosed as soon as possible after the event. Disclosures on the overall framework of the bank could be provided annually. It is recognized that in some regimes, there could be difficulties with the semiannual reporting (lack of appropriate vehicles for disclosure and corresponding audit problems). Banks that make less frequent disclosures should publish a justification. The main rule should be semiannual reporting. On the

other hand, sophisticated banks are encouraged to make disclosures as frequently as possible in line with their national accounting and listing conventions. Especially well-run institutions would benefit from frequent and detailed disclosures.

**Comparability:** It is important that disclosures are transparent and easily comparable among financial institutions such that the market mechanisms can work efficiently. The BCBS and national regulators have suggested templates for the disclosures [52, 63].

More details can be found in [48, 52, 63], where one puts more attention on the reading of the final accord given the evolution of the new capital framework. The disclosures are split up into qualitative and quantitative disclosures:

**Qualitative disclosure:** descriptions, methodology, accountancy methods, regulatory treatment . . . that allow interpretation of the quantitative information correctly,

**Quantitative disclosure:** figures on risk measures, capital and capital ratios, . . .

The specifics of the disclosures are summarized in the next sections. Note that there exists not yet an industry standard disclosure at the moment of writing (2007) and that banks are balancing between avoiding the disclosure of detailed proprietary information and complying with the minimum disclosure requirements.

## 6.5.2 Disclosure requirements

### 6.5.2.1 General principle

The management board should approve a formal disclosure policy. This policy prescribes the banks's approach to the disclosure it will make and the internal controls on the disclosure. Banks are required to implement a process to assess the appropriateness of their disclosures, including validation and frequency of them.

### 6.5.2.2 Disclosures on scope of application

Banks should include information on how the Basel II Capital Accord applies to the banking group and how the firm entities are treated for capital adequacy purposes (Fig. 6.1). One should also inform the markets how the risk

is measured and captured in those entities that may not be included in a consolidated capital calculation like insurance companies.

Qualitative disclosures are concerned with a description of the top firm entity within the group to which the capital standard applies, a discussion on the regulatory and accounting consolidation basis, how entities<sup>95</sup> are treated (full/pro rata consolidation, capital deduction/surplus capital or other), and on regulatory restrictions in the capital transfers between entities in the group.

Quantitative disclosures concern the amount of surplus capital of insurance companies included in the capital of the consolidated group, the aggregated amount of capital deficiencies in non-consolidated subsidiaries and the resulting capital deduction, and the aggregated amount of risk weighted capital in insurance companies that are taken into account via risk weighting rather than via capital deductions or surplus.

Surplus capital exists on the consolidated level when the investment in an unconsolidated regulated subsidiary exceeds the regulatory capital of the subsidiary. The surplus is the positive difference between the investment and the regulatory capital. Vice versa, a capital deficiency is the amount by which the regulatory capital requirement of a subsidiary exceeds the investment. It hardly needs saying that the way these entities are treated from a regulatory and accounting standard impacts the capital ratios at the consolidated level, although the actual risk does not change. Therefore, it is also required to report the impact of the chosen treatment.

### **6.5.2.3 Disclosures on capital**

Disclosures on capital concern the capital structure and the capital adequacy. Qualitative disclosures on the capital structure cover the terms and conditions of the capital instruments used, especially in the case of complex or hybrid capital instruments. Quantitative disclosures include the amount of Tier 1 capital (paid-up share capital/common stock, reserves, minority interests in the equity of subsidiaries, innovative Tier 1 capital instruments, other capital instruments, surplus capital from insurance companies, regulatory calculation differences deducted from Tier 1 capital and other amounts deducted from Tier 1 capital, including goodwill and investments), the total amount of Tier 2 and 3 capital; deductions from Tier 1 and 2 capital and total eligible capital.

<sup>95</sup> Entities are securities, insurance or other financial subsidiaries, commercial subsidiaries, significant minority equity investments in insurance, financial and commercial entities.

**Table 6.20** Overview of the pillar 3 quantitative disclosure requirements for capital adequacy.

**Capital requirements for credit risk:**

separate disclosure for portfolios subject to standardized approach; separate disclosure for portfolios subject to the foundation and advanced IRB approach, respectively; securitization exposures.

**Capital requirements for equity exposures in the IRB approach:**

equity portfolios subject to market-based approaches (simple risk weight method/banking book internal models approach); equity portfolios subject to PD/LGD approaches.

**Capital requirements for market risk:**

standardized approach; internal models approach (trading book).

**Capital requirements for operational risk:**

basic indicator approach; standardized approach; advanced measurement approach.

**Total and tier 1 capital ratio:**

for the top consolidated group; for significant bank subsidiaries.

The qualitative disclosure for capital adequacy aims to provide insight into how the capital adequacy is assessed to support current and future activities. Quantitative disclosures are split up into 5 parts, as reported in Table 6.20.

#### 6.5.2.4 Disclosures on risk exposures and assessment

The disclosures concern key banking risks: credit risk, market risk, interest rate risk, equity risk in the banking book and operational risk. Separate disclosures on credit risk mitigation and asset securitization are included as these techniques can have a significant impact on the bank's risk profile. The disclosures should give market participants more insight into the risk exposure and the internal capital assessment process; and help them in the evaluation of the bank.

##### 6.5.2.4.A General qualitative disclosure requirement

Qualitative disclosures describe risk management objectives, strategies, processes, policies and structure of the risk management function. The scope

and nature of the reporting and measurement systems is also given. As hedging and mitigation of risk may alter the risk profile significantly, disclosures on the concerned policies and monitoring processes should also be provided. These qualitative disclosures should be provided for each of the risk criteria covered in the next sections that describe additional qualitative and quantitative disclosure.

#### **6.5.2.4.B Credit risk (pillar 3)**

General disclosures for all banks concern more qualitative information on the definitions of past due and impaired, allowances, statistical methods, credit risk policies and discussion of migration plans from standardized to IRB approaches and the current partitioning between the approaches. Quantitative disclosures including total gross exposure, average exposure, distribution of exposure, residual maturity, amount of impaired loans, specific and general allowances are reported by categories like geographical breakdown, by exposure type or industry; exposure subject to standardized, foundation and advanced IRB approach.

For portfolios subject to the standardized approach, one provides qualitative information on the ECAIs and ECAs, reasons for changes between agencies, types of exposures covered by the agencies, the process to transfer public ratings to comparable banking book assets, and the alignment of the alphanumerical scale of the agencies to the risk buckets (when a standard mapping from the regulator is not used). Quantitative disclosures provide information on the exposure per risk bucket and the deducted amounts after risk mitigation subject to the standardized approach. For exposures subject to supervisory risk weights in the IRB approach (HVCRE, SL and equities), one reports the exposure in each risk bucket.

For obvious reasons, more complex disclosures are required for portfolios subject to IRB approaches. Qualitative information should be given on the supervisor's acceptance of the approach or for the transition to the IRB approach. The structure of the internal ratings systems, use of internal estimates for other purposes, risk-mitigation process and control mechanisms should be discussed as well. Additionally, one describes the exposure type; the definitions, assumptions, methodologies and data for estimation; the validation of PD, LGD and/or EAD; and the impact of allowed deviations from reference default definitions for the 5 distinct portfolios: 1) firm, sovereign and bank; 2) equities; 3) residential mortgages; 4) qualifying

revolving retail and 5) other retail. Quantitative disclosures consists of two parts:

1. Information on the (current) risk assessment provides per portfolio asset quality information disclosing on a sufficient number of PD grades the total exposure (outstanding amount for equities), the exposure-weighted average risk weight and the exposure-weighted average LGD for advanced IRBA portfolios. For retail portfolios, one may also opt to report the exposure on a sufficient number of EL grades.
2. Information on historical results allows market participants to assess the reliability of the IRB approach. One discloses for each portfolio separately information on actual losses during the past period and explains differences with past experiences, including the main factors. Complementary, comparisons of the bank's internal estimates to resulting losses on a longer time period are also made. If applicable, the comparison is detailed in terms of PD, LGD and EAD.

The disclosures for the IRB approach should be sufficiently detailed to inform market participants on the estimated risk profile, risk assessment processes, and the suitability of the IRB approach without revealing proprietary information or duplicating a detailed supervisory validation of the IRB approach. It is not the goal that market participants perform a detailed validation based upon the available disclosure.

For credit risk mitigation, qualitative disclosures are made regarding netting policies and processes, collateral valuation and management, main types of collateral, main types of guarantors or credit derivative counterparts and their creditworthiness, and concentration on the risk mitigation. From the quantitative part, one reports separately for each portfolio the total exposure covered by eligible financial collateral and other eligible IRBA collateral after application of haircuts, and the total exposure after netting covered by guarantees/credit derivatives.

Qualitative disclosures for securitization include the general qualitative disclosure with details on the bank's objective and resulting risk reduction, the role and involvement of the bank in the securitization process and regulatory capital approaches (RBA, IAA, SFA). Further qualitative information is given on the accounting principles and the names of the ECAs used for securitizations. The quantitative disclosures include the total outstanding exposures that are securitized by the bank and subject to the securitization framework (traditional/synthetic), distribution by exposure type, amount of impaired/past due assets securitized, and losses



recognized during the current period. For securitization exposures retained or purchased by the bank, one reports the total exposure and/or capital charges per exposure type and risk weight band and more details in case of special items, e.g., in the case of entire deduction from Tier 1 capital. For securitizations subject to the early amortization treatment, disclosures should be made per asset type concerning the aggregated drawn exposure attributed to the seller's and investor's interests, the aggregated capital charges incurred by the bank against the seller's and investor's shares of drawn balances and undrawn lines. One should also summarize the current's year activity, reporting securitized exposures and recognized gains and losses.

#### **6.5.2.4.C Market risk (pillar 3)**

Banks using the standardized measurement approach should provide general qualitative information as indicated in the requirements in section 824 [63] and in section 6.5.2.4.A. Quantitative information concerns the capital requirements separately for interest rate risk, equity position risk, foreign exchange risk, and commodity risk.

For banks using the internal models approach, the general qualitative disclosures are supplemented with the model characteristics, stress testing, backtesting, validation, and model consistency for each portfolio. Of course, the scope of supervisory acceptance should also be communicated. Regarding the quantitative part, one reports high, mean, and low value-at-risk values over the reporting period and period end and a comparison of VaR estimates with actual gains/losses with an analysis of outliers in the backtest results. The VaR disclosure provides insight on the risk profile, like asset quality for the credit IRB approach, while the backtest disclosure gives an indication on the reliability of the internal assessment, as is also done for credit risk.

#### **6.5.2.4.D Operational risk (pillar 3)**

Qualitative disclosures are made with regard to the general disclosures as indicated in section 824 [63] and in section 6.5.2.4.A. These are further documented with the description of the advanced measurement approach with a discussion of the relevant internal and external factors. In the case of partial use, one should comment on the scope and coverage of each of the different approaches used. Banks that use the AMA should provide a description on the use of insurance to mitigate operational risk.

Because operational risk is a completely new element in the Basel II Capital Accord that was not present in the first accord nor its amendments, it is expected that the disclosures on operational risk will evolve further with technology and sophistication of the bank's methodologies.

#### **6.5.2.4.E Equities (disclosures for the banking book, pillar 3)**

In addition to the general qualitative disclosures, two aspects are especially important:

1. the differentiation between equity position holdings with the aim of expected capital gains and positions with strategic and relationship reasons,
2. the discussion of policies for valuation and accounting principles for banking book equity holdings.

The latter is important to understand the quantitative disclosures.

For the quantitative information, one reports the value disclosed in the balance sheet of investments, their value and comparison to publicly quoted share values if existing and materially different from the fair value. One should also give more insight on the type and nature of investments, e.g., the split between publicly traded and privately held equity. Information on realized gains/losses resulting from sales and liquidations in the reporting period and total unrealized gains/losses, latent revaluation gains/losses and any of these amounts in Tier 1 and/or Tier 2 capital should be reported. Finally, one also reports capital requirements broken down by appropriate equity groupings with detailed information concerning possible supervisory transition.

#### **6.5.2.4.F Interest rate risk in the banking book (pillar 3)**

The main topics of the general qualitative disclosures are the nature of the interest rate risk in the banking book, the key assumptions made and the measurement frequency. Quantitative disclosures report the increase/decline in earnings or economic value for upward and downward interest rate shocks as specified by the measurement method. These disclosures are broken down by currency type if relevant.

## **6.6 Information technology aspects**

The Basel II Capital Accord has a big impact on the ICT investments for banks. Estimates indicate that 40% of the Basel II budgets goes to data

acquisition, management and archiving; 20–25% goes to IT systems and the remaining 35–40% are used to cover personnel costs [404].

Data management in the Basel II framework is discussed in section 6.6.1. Computation engines are reviewed in section 6.6.2. Data transfer and staging are concisely reviewed in section 6.6.3. Internal and external reporting issues are discussed in section 6.6.4. An example of a global IT architecture is given in section 6.6.5.

### **6.6.1 Data management**

Historical data is used to calibrate the internal rating systems. Data is also fed into the internal rating systems and measures the risk on the current exposures. The data quality and homogeneity required for Basel II has a major impact on the bank's IT systems. The architecture and coherence of the different risk management databases is a complex, but important topic. Moreover, the practical implementation of the data management is organization specific and also depends on historical choices.

#### **6.6.1.1 Data for risk measurement**

The risk measurement is mainly concerned with the calibration of an existing or new developed score function as discussed in Chapter 4. The data for risk measurement involves the collection of the PD, LGD and EAD information. Basel II requires typically long term estimates, e.g., 5 and 7 years to calculate the PD and LGD, respectively.

For PD information, one needs to identify distressed counterparts and label the counterpart as default or non-default, which can make it a complex task to have long-term historical default information. For the calculation of the default rate, one not only needs to have the number of defaults, but also the number of counterparts at least on a yearly basis. Note that for retail pools, one can also consider counterparts per product category. For the retail segment, the PD/LGD approach allows to infer the default rate from the loss and the LGD.

The LGD and EAD calibration requires detailed information on individual defaults. For work-out LGD observations, incoming and outgoing cash flows need to be stored. For market-implied LGDs, the data collection and LGD calculation is less difficult, as explained in Chapter 4. The same holds for the EAD calculation. The calculation of the LGD and EAD is typically done in dedicated databases.

### 6.6.1.2 Data for model development

Model development focuses mainly on the score function design as discussed in Chapter 4. It may also concern the calibration part that was discussed in section 6.6.1.1, although this can be done on a different dataset. To develop a scorecard, first, data needs to be gathered to estimate internal rating systems on past default data or historical ratings.

Commercial external databases with financial statements can be combined with internal or external default or rating histories. Data-pooling initiatives with other banks can be useful on specific sectors with sparse data or low defaults. From these databases, a modelling database is constructed that is representative of the bank's current and future portfolio. The construction of a modelling database is a complex, time-consuming, but very important task as the resulting risk measurement model is essentially an econometric summary of the relations between dependent and independent variables in the database. Therefore, it is important to have standardized and well-documented procedures to process the database. All steps need to be sufficiently detailed so as to provide an audit trail of the modelling database. The data for model development is retrieved from historical databases, the resulting reference dataset is stored for backtesting purposes and future model updates.

### 6.6.1.3 Data for model use

Once the rating systems and risk measurement systems in general are set up, new information and data need to be retrieved to feed the measurement systems. The data retrieval can be a time-consuming task given its availability on different platforms. In addition, information gathering from paper sources continues to become an important manual process in the risk analysis. The data gathering from different sources is a labor-intensive, expensive and error-prone process. Its high cost reduces the frequency at which credit risk assessments are updated.

The extensible business reporting language (XBRL) is the new internet standard specifically designed for business reporting and information exchange. Conceptually, it allows exchange of business information between various systems on different platforms using a common, standardized and universal technology. By receiving XBRL-enabled information from borrowers via the internet, banks with XBRL-enabled systems can immediately extract the required information into the risk assessment computation

engines. Important efficiency and accuracy gains are expected from XBRL-enabled information-exchange systems in terms of the amount of transferred data, data reliability, number of risk factors allowing enhanced risk analysis, frequency of risk assessments and the speed of the analysis. Recall that the Basel II guidelines require updating the risk assessments on at least an annual basis. XBRL is not only expected to streamline the input data stream in the credit risk systems, but also downstream, internal reporting and aggregation of risk reporting between different levels of the bank and even the reporting to the supervisor are improved using XBRL-standardized information exchange [516].

When data is collected from different sources, one needs to determine the priority rules for the data sources. Standardization is required to interpret all data uniformly. For some asset classes, specialized firms collect information for a wide variety of counterparts that is then sold to multiple banks. These data providers realize the scale effect in the sense that the data collection needs only to be done once and can then be distributed amongst multiple customers. The scale effect is important when the provider can collect the information himself and does not need to rely upon multiple customer-data providers.

#### **6.6.1.4 Data for model backtest and review**

The data used to assign a rating and the ratings themselves, are stored for backtesting purposes, risk control, model and rating audits, model refinement, and future developments. In particular, data concerning default rating grades will be stored carefully, including the corresponding financial statements, information for loss given default and exposure at default calculation. Some banks and data providers have dedicated loss databases. The data are stored at centralized databases with appropriate access properties for the different types of users: credit risk managers, financial analysts, portfolio managers, traders and quantitative analysts.

In addition, the relatively low number of credit events implies that, in contrast to market risk, reliable backtesting requires multiple years. As a consequence, the storage capacity of the banks will substantially increase to store the input data and resulting ratings on sufficiently large time horizons. The data for model backtest and review is stored in historical databases. For each backtest, data is retrieved from operational systems and added to the backtest database.

### 6.6.1.5 Data for risk reporting

Risk reporting is an important management tool to follow the risk profile of the organization. Risk reporting is also an important element of disclosure towards financial markets. Regulatory risk reporting has gained importance with the Basel II Capital Accord, especially for IRBA banks. The data for risk reporting can be retrieved from operational internal databases that allow firm-wide consultation of PD, LGD and EAD for concerned departments.

The risk reporting requires detailed information of the exposures of individual positions and retail pools in terms of PD, LGD and EAD information. In addition to the gross risk positions including current and off-balance sheet exposure, also information on credit risk mitigants, guarantees and credit derivatives is required. The risk-reporting databases serve to feed the calculation engines for internal portfolio management and regulatory capital calculation. The operational databases for risk reporting and regulatory reporting are subject to high-quality standards.

### 6.6.1.6 Data quality and standardization

For all phases of risk assessment (model estimation, model application, and result reporting and storage), data quality and data standardization are key elements. Standardization concerns both data-formatting and data-interpretation aspects. Standardized data formats are necessary to achieve a compliant homogeneous data quality that can be efficiently validated.

Good data quality involves good data availability and clean, correct and consistent data content. Data quality can be enhanced, especially at the start-up phase, by data quality software that automatically performs a number of operations that improve data quality: validation, correction, completion of missing values, combination of information from multiple sources, and consolidation of information from different data sources into one global database with a standardized data format. The consistency element is also linked with standardized data interpretation and computation. This means, e.g., that ratios are calculated, at least per sector, in a uniform, standardized way compliant to internal guidelines. For firms, e.g., this implies that coherent and consistent rules exist to take into account goodwill and extraordinary results. The consistency requirement also involves consistent use of ratings throughout the whole financial institution. To each counterpart should apply the same PD and to each product should apply the same LGD in all entities. This requirement involves central databases from which the risk parameters

can be accessed easily by the entities. In general, Basel II will be an important catalyzer for data standardization and centralization.

### **6.6.2 Computation engines**

Different computation engines are required for the computation of the regulatory capital and additional Basel II analysis. For pillar 1 credit risk, the computation engine to compute the risk-weighted assets for credit risk needs to be implemented and linked with the bank's counterpart databases. These computation engines are typically available from many software providers. The scoring functions to estimate the PD, LGD and EAD need to be developed and implemented in banks that apply the internal-ratings-based approach. The design of such models requires extensive databases, statistical and financial expert knowledge. The models are typically developed by a core team of financial and statistical experts that report the progress to a committee of experts that are directly or indirectly involved in the model use, results and application.

#### **6.6.2.1 Risk-assessment-engines**

Depending on the counterpart, the risk assessment is done fully automatized, semiautomated or manual. In behavioral scoring systems for retail, the customer's profile is captured by socioeconomic indicators and behavioral ratios extracted from the current account and (possibly) savings accounts over the last 6–12 months. These indicators can be fully automatically extracted from the bank's databases and fed into the behavioral scoring function. Both ratio computation and risk assessment can be done daily using fully automatic IT systems on the full customer portfolio. In exceptional cases, e.g., loan applications, a complementary manual analysis can be done on a case-by-case basis to take into account extraordinary elements.

For larger counterparts a semiautomated analysis is done, like, e.g., for banks, insurers, firms, public sector entities and sovereigns. The IT system consists of an analytical part that (automatically) feeds the quantitative part with financial figures and resulting ratios and a judgmental part in which the analyst enters his perception on qualitative factors like, e.g., quality of management and market position. Based on these elements, the model rating is computed that is possibly manually adjusted within a specified interval to obtain the final internal rating. When the internal rating is validated by the financial analyst and his hierarchy, the IT system stores the resulting internal rating and all intermediate results necessary to obtain the

internal rating, among which the relevant quantitative and qualitative indicators. Advanced systems allow analysis of potential rating changes when the quantitative data are updated assuming no changes in the qualitative indicators.

In the case of manual rating, no calculation is done, the rating is assigned based on expert knowledge and peer-group comparison. Manual ratings are typically done for very specific counterparts.

### **6.6.2.2 Basel II capital calculation engine**

The calculation of the regulatory capital for credit risk requires the correct implementation of the Basel II rules and the data availability. The main calculation rules have been discussed in section 6.3.1. Data availability concerns the regulatory asset class, calculation approach (standard, foundation/advanced IRBA), PD, LGD, EAD and maturity information. The data feed into such models is a very complex task as it covers a wide variety of asset classes and large amounts of data.

The more complex the approach, the more information is needed and the more complex are the calculations. In particular, the use of risk mitigants complicates the regulatory calculations. The computation engine needs to be sufficiently complex and flexible to capture all the specificities of the Basel II computations.

### **6.6.2.3 Internal portfolio capital calculation engines**

These calculation engines perform portfolio model calculations to compute the loss distribution of portfolios as explained in Chapter 5 and in book II. The data collection for these portfolio models is a complex process: it is essentially similar to the Basel II calculation engine data collection, but is more difficult because the internal portfolio model is typically more complex than the generic Basel II portfolio model. Apart from the Basel II-like computations, the structuring of the (mother–daughter) relations between different counterparts, collateral data, . . . , are complex tasks. In addition, concentration effects can be taken into account. The computational complexity of these models varies depending on the model formulation: analytical expressions or Monte Carlo simulations.

Banks apply internal portfolio models for internal risk assessment, economic capital calculation and sensitivity and scenario analysis. The results of the internal bank portfolio models are typically more specific to the internal bank portfolio than the general Basel II pillar 1 expressions. The results



of the internal portfolio models allow assessment of some aspects of pillar 2, like, e.g., impact of possible correlation between PD, LGD and EAD, the impact of concentration risk, and the impact of correlations between credit, market, interest rate and operational risk.

#### **6.6.2.4 Stress test engines**

Additional computation engines perform scenario and sensitivity-based stress tests required for pillars 1 and 2. Such analyses are typically done first on a portfolio basis, where different macroeconomic parameters are changed and the impact on the portfolio loss distribution is measured as well as the impact on the business as a whole with, e.g., impact on the margins. Stress-test engines require similar information as regulatory information. Additional information may be required for some specific scenarios.

The implementation of the stress-test scenarios depends on the complexity of the scenarios. Simple scenarios (e.g., downgrade of one asset class or counterparts in one region) can be calculated by the regulatory capital engine, other scenarios (e.g., increase of credit spreads) are performed by the portfolio calculation engine. The results of the different scenarios on the different portfolios are then aggregated (together with the results from market and operational risk stress testing) on the group level for which one computes the overall impact of the different scenarios. From an IT perspective, stress testing generally makes use of existing computation engines from which results are generated on a portfolio level and aggregated on a group level. Stress testing will be discussed extensively in book III.

#### **6.6.3 Staging and data transfer**

Extraction, transformation and loading (ETL) tools enhance the data flow from databases to computation engines. At the same time, they can perform standard data-quality validation checks.

Staging engines and data-quality steps are necessary to ensure the reliability of the results. These elements are performed by manual spot checks and automated processes.

#### **6.6.4 Reporting**

Internal and external reporting of capital adequacy is an important aspect of the Basel II Capital Accord. In particular, pillars 2 and 3 are involved with monitoring and supervision of the banks' capital levels. Risk exposure,

capital level, capital ratios, results of stress tests, etc., are reported internally to senior management and to the board members. Results are also reported to the supervisor. Pillar 3 requires communication of risk exposure, capital and capital ratios to the financial markets, as well as the risk assessment methodology. As the reporting task is a repetitive task without a lot of added value itself, reporting is often highly automated.

The results of the computation engines will be summarized into standardized reports that will be communicated to the different parties involved. Dedicated software will be used to automate the reporting. This reporting software needs to be grafted onto the computation engines data marts. Standardized information exchange will be done using the extensible business reporting language (XBRL). The Committee of European Banking Supervisors (CEBS) has defined the common solvency ratio reporting framework<sup>96</sup> (COREP) that adopts a common technology platform based on XML/XBRL language. It aims to promote a standardized reporting and a level playing field for banks and credit institutions that fall under the European Capital Requirements Directive. Together with the COREP framework, the financial rep (FINREP) is defined for financial institutions that use IAS/IFRS for their published financial statements.

### 6.6.5 Global ICT architecture

A blueprint of the global integrated IT infrastructure for Basel II purposes is reported in Fig. 6.9 [207, 394, 490]. In the business lines, local databases for credit, market and operational risk are completed. For credit risk, such databases consists of counterpart and facility information: exposure, credit line, exposure at default, default and loss risk, PD correlation, collateral and risk mitigation, key financial indicators, . . . Dedicated databases for default and loss information are stored at the business level. Some banks also have centralized loss databases. Note that from an ICT viewpoint, these databases may be implemented in various ways (e.g., flat files, hierarchical databases, Codasyl databases, relational databases, . . .).

The relevant information of these databases is then extracted, transferred and loaded into the central data warehouse. The central data warehouse is typically located in the firm center where the local databases are stored at the business lines. The data warehouse centralizes all relevant information

<sup>96</sup> See [www.corep.info](http://www.corep.info) for more details.

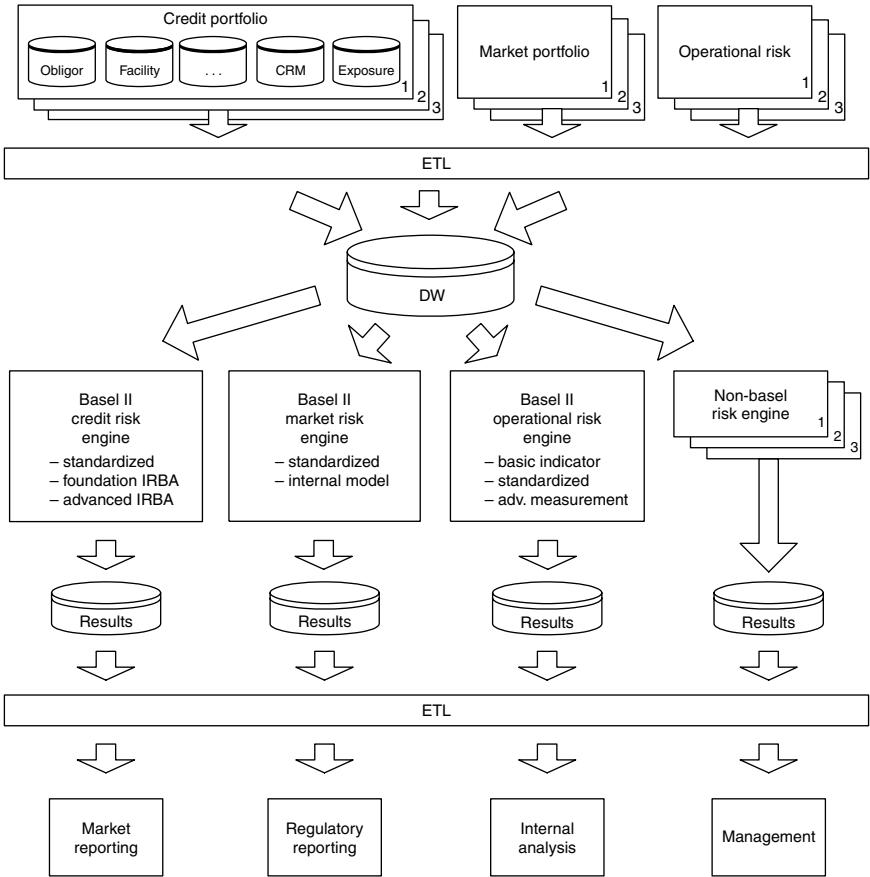

**Fig. 6.9** Example ICT architecture for Basel II. The information on the credit and market portfolios and operational risks are gathered from the different business lines into a central data warehouse from which the risk weights and capital requirement for credit, market and operational risk are computed. Other computation engines, e.g., for economic capital or stress testing are also fed with the central firm-wide database. The results are presented on dedicated data marts from which the internal and external reporting is done.

on the bank’s counterparts and facilities, among which are qualitative information like identity number, name, counterpart and product type, possible mother and daughter companies, guarantors; and quantitative information like exposure, default and loss risk, collateral. The central database also enforces one consistent firm-wide risk assessment per counterpart and facility as it enables a central information kiosk at which the internal ratings can be consulted. It is important that this data warehouse implements a uniform and consistent data model in order to be able to store and

capture as much of the source data as possible. The central data warehouse is connected to the operational databases of the business lines via a data extraction, transformation and loading (ETL) step. In this ETL step, data inconsistencies are reported automatically for manual or semimanual repair.

The information of the credit databases, together with all market portfolio and operational risk data, will then be merged into a central data warehouse in order to provide a firm-wide view on all data and risk sources. The data warehouse will then feed the different risk engines calculating credit risk, market risk, operational risk, and other types of risk. The calculation engines may be implemented using Web services and standards (SOAP, XML, . . .) in order to make them easily accessible and available across platforms. The calculation engines apply the appropriate rules depending on the portfolio. Apart from the regulatory capital engines, other computation engines for internal portfolio models (e.g., for additional pillar 2 reporting), economic capital calculation, stress testing, provisioning and marketing can use the data of the central data warehouse.

The results of the engine calculations will be stored in data marts, which can then subsequently be used for various reporting purposes such as market reporting (e.g., pillar 3 in Basel), regulatory reporting, internal analysis and/or reporting to management. The different end-users have access to partial or full information that is used for (semi)automated reporting. Internal reporting is done to senior management and management board. External reporting is addressed to the regulator and financial markets. From an ICT viewpoint, reporting tools will be used that should be equipped with adequate visualization facilities. An example could be online analytical processing (OLAP) facilities that allow for multidimensional data analysis and visual reporting. The bank's complex portfolio can be represented in an intuitive and transparent way to the senior management, e.g., exposures, risk levels, and their evolution per rating class, per region, per product, or per counterpart type.

Note that it is important that the overall ICT architecture is implemented using appropriate authorization and control facilities, versioning facilities, documentation facilities, backup and recovery facilities, and also a helpdesk infrastructure. Furthermore, when the ICT architecture is implemented for a large international financial conglomerate, one may also consider using distributed and/or grid computing to improve performance, efficiency and availability. The latter holds especially for computationally intensive tasks like portfolio models. For efficiency reasons, the process is automated as

much as possible for cost efficiency and reduction of human error. Quality control checks are made at the different steps of the process to ensure reliability of the results.

For smaller banks, the creation of an integrated IT architecture like in Fig. 6.9 can be very costly. For such banks, an incremental architecture can be more interesting, where no central data warehouse is created and where the Basel II data is extracted directly from existing databases for the calculation of Basel II figures.

## **6.7 Market impact**

Banks are a major player in the economy and Basel II introduces a major change in banking regulation. The changes on banks will cascade further on to their stakeholders. First, quantitative results on the impact of the Basel II Capital Accord on the bank's capital requirements are discussed in section 6.7.1. The impact of the new capital accord for banks and borrowers is discussed in section 6.7.4 and section 6.7.5, respectively. This book is concluded with a discussion on the impact for the economy as a whole in section 6.7.6.

### **6.7.1 Quantitative impact studies**

The impact of the new pillar 1 capital requirements for credit, market and operational risk has been monitored via quantitative impact studies (QIS). These studies have allowed regulators and banks to assess the impact of the new capital rules compared to the Basel I Capital Accord. The first impact study (QIS1) was organized in 2000. In 2005, the fifth study QIS5 was held and the results are reported in [64, 117].

#### **6.7.1.1 Methodology and main results**

The impact studies reported the changes in capital requirement for various asset classes and for two types of banks:

**Group 1:** These are large international banks with a diversified portfolio and with original own funds in excess of €3 bn.

**Group 2:** Banks that do not meet the 3 criteria of group 1. These are typically smaller, locally active banks or niche players.

For each type of asset class and for each type of bank, the results have been summarized into several reports from the BCBS and local

**Table 6.21** Incentive structure for credit and operational capital requirements (CEBS QIS5 survey [64, 117]). On average, the application of a more risk-sensitive approach is rewarded by lower requirements. It should be noted that the reported differences are valid on average and may vary significantly across financial institutions. The average portfolio compositions are reported in Fig. 6.10.

	Credit risk			Operational risk	
	IRBAf/SA	IRBAa/IRBAf		SA/BIA	AMA/SA
Group 1	-13.5%	-6.8%	Group 1	-5.6%	-17.0%
Group 2	-12.4%	-6.7%	Group 2	-12.3%	N.A.

**Table 6.22** Change in minimum capital requirement for credit risk relative to Basel I (QIS5 survey [64, 117]). The last column indicates the most likely approach that will be applied by the participating banks under Basel II.

	S.A.	IRBAf	IRBAa	Most Lik.
EU Group 1	-0.9%	-3.2%	-8.3%	-7.7%
EU Group 2	-3.0%	-16.6%	-26.6%	-15.4%

regulators, e.g., [64, 117]. The results of the QIS5 are reported for G10 and non-G10 banks. Results for the CEBS countries are also reported [117], which are the basis for this summary as it provides the most detailed information. The results for the other groups are largely comparable. An indication of the Basel I RWA composition of the participating banks is reported in Fig. 6.10. Besides the impact on capital requirements, the impact study results also provide interesting benchmark results, like the number of banks that opt for one of the possible approaches and average risk parameters per asset class.

Table 6.21 reports the average relative difference between the various approaches for credit risk obtained from the QIS5 [64, 117]. When a more risk-sensitive approach is applied, less capital is required on average. Because capital of itself is not sufficient to avoid bank failures, the investment in a stronger risk measurement and management, needed for the more risk-sensitive capital approaches, is rewarded by lower average capital requirements. Note that the reported values in Table 6.21 are valid on average. The differences between the different approaches can vary considerably between banks.

The average impact of the new capital rules (QIS5 results) compared to the Basel I rules is reported in Table 6.22 [64, 117]. The differences

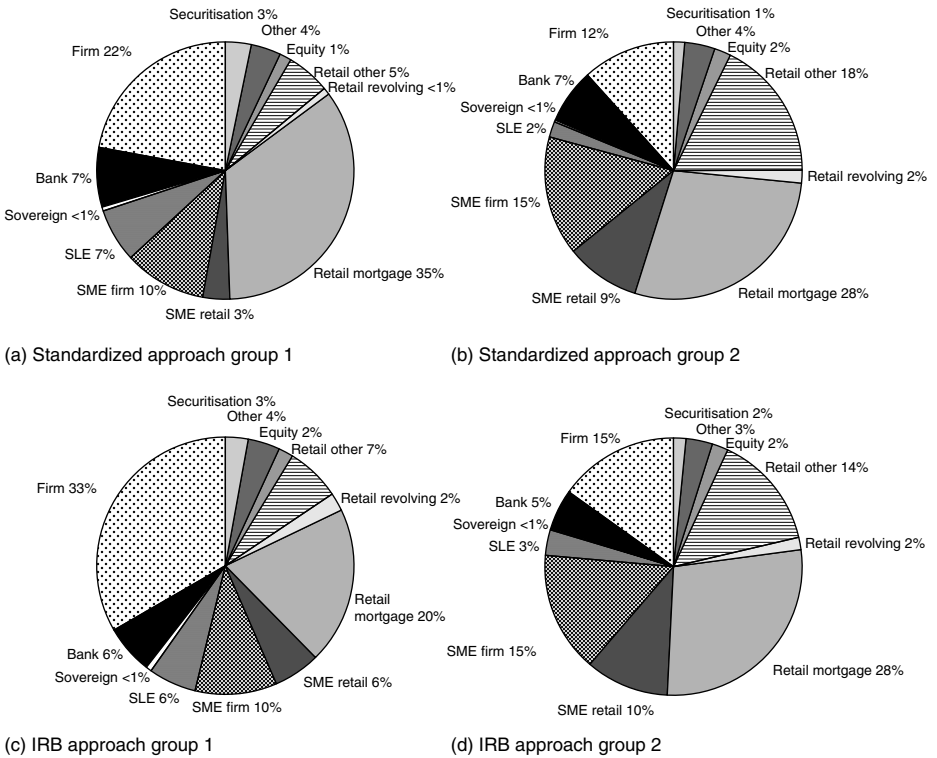

**Fig. 6.10** Portfolio RWA compositions of the participating banks in the QIS5 study for the CEBS countries [64, 117].

are the lowest for the standardized approach and are the highest for the advanced internal-ratings-based approach. The average impact on capital requirements for various asset classes is reported in Table 6.24 and will be discussed further in the next section. The contribution of the operational risk capital charge to the minimum capital requirement from the QIS5 analysis is reported in Table 6.24. The relative importance ranges from about 9% to about 5% and is the highest for the advanced measurement approach. This illustrates the incentive structure of the capital rules to apply more risk-sensitive approaches calibrated on internal data. For group 1 banks, the incentive from standard to basic indicator approach is 5.6% less capital requirement, as reported in Table 6.21. When moving further from the standardized to the advanced measurement approach, the capital requirement for operational risk reduces further to 17.0% [64, 117]. For group 2 banks, insufficient information was available on all approaches to infer reliable statistics. Where necessary, the capital rules have been adjusted as a

**Table 6.23** Overall results comparing the minimum capital requirements (MRC) of the Basel II standardized, foundation IRB, and the advanced IRB approach relative to the Basel I accord (QIS5 survey, CEBS countries [64, 117]).

Portfolio	Standardized Approach						Foundation IRBA						Advanced IRBA					
	Group 1			Group 2			Group 1			Group 2			Group 1			Group 2		
	% MRC (current)	change (%)	Contribution	% MRC (current)	change (%)	Contribution	% MRC (current)	change (%)	Contribution	% MRC (current)	change (%)	Contribution	% MRC (current)	change (%)	Contribution	% MRC (current)	change (%)	Contribution
Wholesale																		
Firm	17.7%	-1.9%	-0.3%	10.1%	-6.1%	-0.6%	24.0%	-9.6%	-2.3%	10.9%	-21.2%	-2.3%	25.2%	-17.6%	-4.4%	11.8%	-44.5%	-5.3%
Sovereign	0.4%	97.6%	0.4%	0.2%	27.2%	0.1%	0.5%	276.8%	1.5%	0.1%	314.7%	0.5%	0.4%	178.1%	0.8%	0.1%	687.1%	0.5%
Bank	6.0%	29.0%	1.8%	6.0%	-11.1%	-0.7%	4.9%	7.7%	0.4%	4.0%	-16.4%	-0.8%	3.0%	1.8%	0.1%	3.0%	8.6%	0.3%
SME firm	8.3%	-5.1%	-0.4%	13.0%	1.5%	0.2%	6.9%	-6.5%	-0.5%	14.0%	-11.6%	-1.7%	7.2%	-23.6%	-1.7%	11.1%	-45.2%	-5.3%
SLE	5.4%	-6.4%	-0.4%	1.7%	-0.6%	0.0%	4.2%	4.7%	0.2%	2.5%	20.8%	0.6%	4.9%	-24.6%	-1.2%	2.6%	-17.7%	-0.6%
Retail																		
Mortgage	27.7%	-28.2%	-7.8%	24.5%	-28.5%	-7.2%	14.2%	-65.7%	-9.4%	25.3%	-63.9%	-16.3%	12.9%	-65.4%	-8.5%	7.9%	-64.6%	-5.1%
Other retail	4.4%	-23.6%	-1.0%	15.3%	-20.0%	-3.1%	5.0%	-15.4%	-0.8%	11.6%	-42.2%	-5.9%	4.4%	-23.2%	-1.0%	32.5%	-44.0%	-15.0%
Revolving	0.7%	-22.9%	-0.2%	1.4%	-22.3%	-0.3%	1.6%	52.5%	0.9%	1.4%	-26.0%	-0.5%	1.5%	71.1%	1.1%	1.2%	-62.2%	-1.0%
SME retail	2.7%	-22.2%	-0.9%	8.1%	-20.6%	-1.7%	4.2%	-50.2%	-2.1%	6.5%	-43.9%	-2.9%	4.1%	-48.5%	-2.0%	12.2%	-57.0%	-7.3%
Equity	1.2%	18.3%	0.2%	1.8%	1.8%	0.0%	1.3%	88.8%	1.2%	1.6%	124.5%	2.1%	1.3%	67.3%	0.8%	0.9%	175.4%	1.9%
Purchased receivables	0.1%	-19.3%	-0.1%	0.2%	-0.7%	0.0%	0.1%	-36.9%	-0.1%	0.2%	3.2%	0.0%	0.0%	75.3%	0.1%	0.0%		
Other exposures	3.0%	0.0%	0.0%	3.3%	0.0%	0.0%	2.9%	0.0%	0.0%	3.2%	0.0%	0.0%	2.8%	0.0%	0.0%	4.8%	0.0%	0.0%
Securitization	2.6%	12.9%	0.4%	1.2%	5.0%	0.1%	2.3%	3.2%	0.1%	1.4%	12.9%	0.2%	2.3%	19.4%	0.4%	0.4%	20.3%	0.2%
Trading book CCR	1.6%	34.4%	0.9%	0.1%	46.6%	0.1%	2.3%	17.8%	0.4%	0.2%	11.1%	0.0%	3.5%	5.9%	0.2%	0.2%	15.0%	0.0%
Specific risk	1.3%	6.5%	0.1%	0.4%	2.6%	0.0%	1.5%	6.3%	0.1%	0.5%	-1.0%	0.0%	1.3%	0.5%	0.0%	1.4%	-0.2%	0.0%
General market risk	2.1%	0.9%	0.0%	1.7%	0.0%	0.0%	2.9%	-0.9%	0.0%	2.7%	0.3%	0.0%	2.3%	-0.6%	0.0%	1.3%	-0.2%	0.0%
Related entities	5.7%	19.9%	2.0%	2.3%	37.2%	0.9%	6.0%	13.1%	0.9%	3.0%	38.5%	1.2%	8.3%	12.2%	1.0%	4.2%	29.7%	1.3%
Large exposures	0.2%	0.0%	0.0%	0.2%	0.0%	0.0%	0.2%	0.0%	0.0%	0.1%	0.0%	0.0%	0.0%	0.0%	0.0%	0.1%	0.0%	0.0%
Deductions	5.0%	-0.5%	0.0%	3.2%	-1.2%	0.0%	12.4%	-0.1%	0.0%	2.9%	0.0%	0.0%	10.9%	0.0%	0.0%	2.5%	-0.1%	0.0%
Partial use	4.0%	-3.2%	-0.2%	5.2%	1.2%	0.1%	2.7%	23.2%	0.9%	7.9%	3.1%	0.3%	3.8%	-7.3%	-0.3%	1.9%	9.1%	0.2%
Operational risk			5.5%			9.0%			5.8%			7.9%			6.3%			7.5%
<b>Overall change</b>	<b>100.0%</b>	<b>-0.9%</b>	<b>100.0%</b>	<b>-3.0</b>	<b>100.0%</b>	<b>-3.2%</b>	<b>100.0%</b>	<b>-16.6</b>	<b>100.0%</b>	<b>-8.3%</b>	<b>100.0%</b>	<b>-8.3%</b>	<b>100.0%</b>	<b>-26.6%</b>	<b>100.0%</b>	<b>-26.6%</b>	<b>100.0%</b>	<b>-26.6%</b>



**Table 6.24** Contribution of the operational risk capital charge to the minimum capital requirement for the different approaches. (QIS5 survey [64, 117]).

Approach	OR contribution (%)	
	Group 1	Group 2
Basic indicator approach		8.8%
Standardized approach	5.5%	7.9%
Advanced measurement approach	5.9%	5.4%

result of the analyses. An important adjustment is the scaling with 1.06 of the capital rules to sustain the current capital levels in banks.

### 6.7.2 Impact per asset class

A main result of the QIS and related studies [64, 117, 274, 400] are the changes in capital requirements for each of the asset classes and the regulatory capital calculation methods. The results for the CEBS countries have been summarized in Table 6.23. For each asset class, bank group and regulatory approach, the relative contribution to the first accord (Basel I) is reported in the first column. The relative change in capital requirements from Basel I to Basel II is reported in the second column. The contribution to the total change in capital requirement is reported in column 3 and is obtained as the product of the previous columns. The relative Basel I capital requirement is visualized in Fig. 6.10. The changes are discussed for the regulatory asset classes of Table 6.5:

**Sovereigns:** The overall capital requirement for sovereigns increases with the rating in the standardized approach (Table 6.6). In the Basel I requirements, no capital was needed for exposures on OECD countries that received a 0% risk weight. Such a distinction between developed and developing countries is no longer made in Basel II, the risk weights depend on the rating. Exposures on lower-rated OECD countries are likely to be higher risk weighted under Basel II. The opposite holds for higher-rated non-OECD sovereigns. Because sovereign exposures count (on average) for a low proportion of the bank's balance sheet, the overall impact on the capital requirements is relatively low. As is observed from Table 6.23, the relative differences can be very high due to the low current risk weights. This data sensitivity makes a comparison across the three regulatory approaches rather difficult. It is expected that the principle of the incentive for more risk-sensitive approaches holds,

although conservative measures are applied to capture methodological uncertainties.

**Banks:** The standardized risk weights for banks will generally increase from Basel I to Basel II, because the risk weights are no longer determined whether or not the banks are incorporated in an OECD country. Especially under option 2, lower-rated banks in the A range and unrated banks will be risk weighted higher. Under option 1, where the bank's risk weights are one notch below the country risk weights, stronger banks in lower-rated countries are penalized.

In the foundation IRB approach, the increase in risk weights is much lower than under the standardized option 2 approach. The advanced IRB approach allows financial institutions to assess the LGD of banks. As these assessments tend to be lower than the foundation 45%, the capital requirements are lower. Subordinated bank debt is only limitedly available in the bank's assets, but with the IRB approaches, such investments are favored by a lower risk weight [274].

**Firms:** In the standardized approach, the capital requirement is reduced by about 0–5% compared to the current Basel I framework. In countries and sectors with many counterparts having a risk weight below 100%, the reduction tends to be higher than in other countries.

The reduction in risk weight is much higher when applying the foundation IRB approach. A main explanation is that most portfolios of banks are of good quality with ratings in the BBB zone or higher. For the advanced IRB approach, the capital requirements are even further reduced, explained by both lower unsecured LGDs and the impact of collateral.

**MidCorp:** Small and medium-sized enterprises fall into the regulatory asset classes of firms (with correlation function adjustment) and retail. In most cases, capital gains have been reported, especially for those treated as retail. When the enterprises are treated as firms, their rating can be relatively weak and the risk weight can exceed 100%. The highest capital reductions are observed under the advanced IRB approach, allowing both internal PD and LGD estimates.

**Retail:** Capital reductions for the retail segment are very important. It can amount up to 70% in some countries.

The reduction of the risk weights from 50% to 35% for residential mortgages and from 100% to 75% for other retail exposures allows important capital amounts to be saved in the standardized approach.

Mortgages are an important part of the retail exposures and allow even more important capital gains in the IRB approach. The gains are especially

high in countries with low historical LGD values in the residential retail market.

In the IRB approach for other retail assets, the capital reduction ranges from 15% to 45%. Revolving credits are a less important part of the portfolio and the impact of capital requirements varies across the groups and the approaches. In general, the tendency is that also for this type of exposures, less capital is required.

**Equities:** Equity exposures typically represent only a limited portion of the banking book portfolio. Therefore, the impact on the bank's capital requirement is rather limited. The IRB equity rules clearly indicate an increase in capital requirements, which will not always be immediately applicable due to the grandfathering option. The increase is larger in the IRB approaches than in the standardized approach, as is observed from Table 6.23.

**Securitization:** The detailed results<sup>97</sup> of the CEBS study indicate that the risk-weighted assets for group 1 banks increase with 21.2% in the standardized approach, while in the IRB approach the increase is limited to 7.9%. For group 2 banks, the capital reduction is 3.9% under the standardized approach and 14.6% under the IRB approach. The results indicate that the incentive structure works properly. Note, however, that the risk sensitivity for securitization assets is very high, as illustrated in the risk weights for the standardized approach in Table 6.6. This risk sensitivity and the different portfolio composition explains the difference between group 1 and group 2 banks. Group 1 banks are more involved in the origination and sponsoring of securitization deals, which implies that they hold more frequently deeply subordinated tranches and provide liquidity facilities. Group 2 banks are mostly investing in high-quality tranches that benefit from a lower risk weight under Basel II. The difference between the standardized approach and the hierarchical IRB approach is mainly due to the internal assessment approach that allows more issues (mainly facility agreements) to be treated in a risk-sensitive way.

The impact for other assets is reported in Table 6.23. More detailed information can be obtained, e.g., [64, 117, 400].

<sup>97</sup> Note that the results reported in the QIS5 of [64, 117] are denoted in Table 6.23. For the interpretation of these results, it has to be remarked that data quality on securitization does not match the data quality on the other asset classes. Therefore, the impact on the securitization asset class is reported on a high-quality data subset in [64, 117].

### 6.7.3 International differences

The new capital accord will not be implemented everywhere at the same time and with the same complexity. Basel II gives local regulators the authority to tune the capital requirements to the local risk profile. In the next sections, the main implementation issues for Europe, the US, Japan, and emerging markets are reviewed.

#### 6.7.3.1 European Union

The Basel II Capital Accord will be implemented in the European Union via the Capital Requirements Directive (CRD). Where the Basel II rules take the form of an agreement amongst the national supervisors represented in the BCBS (see Table 1.4), which in principle remains voluntary, the EU requirement is legislative and binding in all EU Member States. It is implemented via the Lamfalussy<sup>98</sup> procedure, where the CEBS has an important responsibility to ensure a consistent implementation across the Member States to create a level playing field in the single market. National options are reduced in the final CRD and some remaining national directions are intended to become obsolete over time.

There are some specific elements on the EU implementation that distinguishes the CRD from the Basel II Capital Accord for reasons of the single-market-specific circumstances. The main elements are

**Scope of application:** The scope of the application is extended from internationally active banks in Basel II to all banks and (recognized) investment firms in the CRD, independent of their size or geographic scope. This will ensure that all financial institutions in the EU market face the same capital requirements. The CRD is also applicable on both a consolidated and on an individual basis, unless the requirements for a domestic subsidiary are waived and guaranteed by the parent. As discussed in section 6.1, Basel II is applicable on a (sub)consolidated basis and only on individual banks in

<sup>98</sup> The Lamfalussy approach envisages increased flexibility in the EU legislative process such that legislation can better keep up with developments in financial markets. The approach defines 4 levels for the legislative process. 1. European Community legislation is advanced by the European Commission and adopted by a co-decision procedure involving the Council and the European Parliament. 2. Technical details of the level 1 framework enacted by the European Commission who is the chair of regulatory committees on banking, securities, insurance and pension funds, and financial conglomerates and where the European Central Bank has an observer status. 3. Supervisory committees (like the CEBS) are responsible for the day-to-day implementation of the Community law, for the convergence of supervisory practices and for the enhancement of supervisory co-operation. 4. The European Commission supervises the correct and coherent implementation of the Community Law in the Member States' national law.

a group when these individual banks themselves qualify as internationally active banks.

**Range of available approaches:** The full spectrum of available approaches ranging from the simple to the advanced methods is available in the EU. Because the capital accord is applicable for all banks, the role of the permanent partial use is extended. For example, when a bank applies the IRB approach to some of its asset classes, it should move to the IRB for all of its asset classes. However, for smaller banks, the application of the IRB approach to specific asset classes like sovereigns, banks and financial institutions may be particularly hard such that these exposures are allowed to be treated in the standardized approach, while other exposure categories are treated in the IRB approach. Also for certain investment firms, specific simplifying rules concerning operational risk capital charges are applicable.

**Supervisory disclosure:** On top of pillar 3 disclosure requirements for banks, the CRD also specifies disclosure requirements for the Member States' competent (supervisory) authorities. These requirements range from the publication of legal text and rules, general criteria and documentation on methodologies and supervisory inspections, till aggregated statistical data on key implementation aspects. These disclosures aim to enhance supervisory convergence and transparency and to contribute to the regulatory level playing field.

**Risk weights:** The impact of the changing risk weights for key European sectors like private equity, small and medium-size enterprises, real-estate lending and covered bonds has been monitored closely. For the SME segment, the interaction with the BCBS resulted in adjusted regulation for SME (both in the retail and firm segment). For private equity and covered bonds, specific treatments are described in the CRD. Beneficial treatments reflect specific lower risk characteristics that were not addressed in Basel II. For commercial and residential real estate, the CRD rules impose a higher coherence between the standardized and IRB approaches. The preferential Basel II risk weights for collateralized RRE lending are applicable in the CRD on condition that two independence criteria are met:

1. Borrower risk does not influence property value. This criterion may exclude special property that is tailored to the needs of the borrower and can be difficult to resell.
2. Property value does not influence borrower risk. This criterion may exclude firms that specialize in owing and letting real estate.

For CRE, the preferential risk weight of 50% instead of 100% is applicable when restrictive criteria apply that require historical sufficiently low regional loss rates (section 6.3.1.1). In the CRD these requirements are less stringent, because these restrictive criteria are only applicable in the case of the second independence criterion.

Other specific attention points are the homogeneous rules for the recognition of ECAIs, the homogeneous mapping of recognized ECAI ratings to supervisory standard risk weights, enhanced responsibilities of the consolidating supervisor with clarification of home-host issues between different supervisors and the monitoring of possible procyclical effects.

### 6.7.3.2 United States

The spectrum of approaches available in the Basel II Capital Accord is confined by the US authorities [181]. Large internationally active banks (with consolidated asset exceeding US\$250 billion and foreign exposure of at least US\$10 billion), including subsidiaries of foreign banks, will be required to apply only the advanced approaches to calculate minimum capital requirements: the advanced IRB approach (credit risk) and the advanced measurement approach (operational risk). These banks are called the mandatory IRB banks. Other, so-called opt-in, banks that meet the requirements for the advanced approaches will also be allowed to opt for Basel II. In both cases, it concerns about 10 banks, being the banks active in cross-border banking that hold most of the foreign assets and a large portion of the top 50 US bank assets. The results of the QIS4 revealed that the reduction in capital requirements exceeded the expectations, such that the US authorities proposed to postpone the implementation of Basel II in the US [182] with a one-year delay and take the time to introduce additional safeguards to maintain capital levels. Floors on capital rules are likely to remain applicable after 2011 and can be reconsidered on an individual basis, e.g., based on economic capital.

The other about 6500 local US banks and subsidiaries of foreign banks that do not meet the US criteria to implement Basel II will remain under the current Basel I rules. Some of these rules are made somewhat more risk sensitive and are called “Basel IA” rules. These changes can have important implications for foreign subsidiaries. A foreign subsidiary of a non-US banking group applying the foundation IRBA will be required to apply the Basel IA rules. These restrictions may limit the level playing field, which

remains an attention point for the Accord Implementation Group (see section 1.7.2). It is not unlikely that US authorities may allow other rules in the future.

### **6.7.3.3 Japan**

The Japanese banking sector has experienced a large number of bad loans in the last 10 years as reported in Table 1.5. Problems of bad loans eroded their capital levels and many banks quit their international activities to concentrate on their problems. The capital base of the early 1990s decreased further because of double-gearing effects and an important decrease in the market value of insurance and bank equity investments due to the bearish stock market conditions. The 2003 IMF stability report states that the system remains fragile. In some discussions, it is questioned whether the Basel II implementation, with the important IT investments, is the priority for the Japanese banking system [237, 277, 493].

In general, the new Basel II Capital Accord will not have an important impact on the bank's capital levels, in contrast to other countries. Although some asset classes may observe significant reductions, these reductions are offset by the increased capital requirements for the risky non-performing loans.

Market observers report that an important contribution of the new capital accord is the improvement of risk management techniques and the increased use of risk assessment in profitability analyses like RAROC. The Japanese banks have used an informal "Main Bank" system where a lead bank monitors the credit quality of a counterpart on behalf of other lenders. This system is likely to lose importance as banks are required to have internal risk assessments. Banks with a leading customer relation are expected to reduce exposure concentrations, e.g., by syndicated loan transactions.

The Japanese banking sector consists of a small group of large and very large banks and a high number of small banks. Larger banks have important commercial bank activities, whereas medium and small banks have important retail activities. During previous years, concentrations reduced the number of banks, some of the mergers were aimed to reduce the problem of non-performing loans. With the decrease of capital charges for retail, larger banks are expected to move further to this interesting asset class.

The Japan Financial Services Agency (FSA) introduced in 2002 the "Takenaka" plan to reduce the bad loan ratio by 50% in 2004. The high

Basel II capital charges for non-performing loans are a further incentive for banks to reduce their bad assets, while the FSA has a more important role to monitor bank capital levels compared to the Basel I regime.

Because of their problems, Japanese banks themselves are lower rated by the classical rating agencies than banks in other developed countries. As banks are subject to higher risk weights and especially weaker banks, Japanese banks are expected to see their funding cost increase and to observe higher prices in transactions (e.g., derivative products) with other banks.

Although Basel I did not really prevent the 1990s Japanese banking crisis, market participants are generally positive that Basel II rules will improve financial stability because of the improved risk monitoring and the reduced importance of bank–customer relations of the main-bank system. It is generally accepted that there are other important priorities, like the reduction of non-performing loans.

#### 6.7.3.4 Other countries

The application of the Basel II Capital Accord in other countries depends on local regulation. Although the Basel I Capital Accord was only agreed amongst the BCBS members, it became the international standard in almost all countries. Also, the Basel II Capital Accord will become the standard in most countries, where local regulators will make use of the flexibility possibilities to tune the capital requirements to local risk profiles and economic structures within a convenient implementation time schedule.

More particularly, for emerging markets, some specific difficulties on the Basel II implementation have been raised. The implementation of the standardized approach is limited by the low number of external ratings. The use of the simplified standardized approach (Appendix 11 of [63]) that has a limited risk sensitivity and allows alternatives when there are no external ratings is an important option for emerging markets. IRBA implementations are hampered by the limited internal data and the limited capacity of auditors and supervisors to control data and validate internal risk models. The lower reliability of accountancy information in emerging markets also makes it more difficult to apply objective statistical techniques for IRB approaches. Supervisory validation of IRBA models can simply be too heavy and too complicated a task at this moment. When it comes down to the quality of bank supervision, many emerging countries comply at the time of writing with the international standards of the Basel Core Principles (BCP) [47].



It is a question of priorities for supervisors. The legal framework in emerging countries is often less creditor friendly, such that, e.g., the strict rules for collateral recognition are not applicable. Supervisors may even not have the moral and legal authority to impose additional capital buffers under pillar 2 or to enforce timely remedial actions. The pillar 3 disclosure enhancement is not yet an issue as accountancy information quality is still an area for improvement.

The operational risk framework is a new framework and is even quite complex to implement in developed countries due to data and technology issues. In emerging countries, these difficulties will be even more important such that a quick implementation of the more advanced and sophisticated measures is unlikely. When techniques mature in developed countries, they are expected to be implemented in emerging countries with a limited delay.

Note that in emerging markets, banks may be daughter companies of industrial conglomerates and may be ruled by the political and business elite, which may result in compromised positions. The financial stability of the bank system is also more closely related to macroeconomic policy and performance than in developed countries. As policy and performance are more volatile and beyond supervisory control, this puts the above comments more into perspective.

The increased Basel II risk sensitivity will also impact lower-rated emerging countries and their companies: spreads will increase and/or credit will be rationed. Although Basel II may not be implemented immediately in emerging countries, international banks will apply it also in emerging markets. The differences in capital requirements will disturb competition with local banks who will need to convince their supervisory authorities to implement Basel II to keep up. Likewise, international banks will face the issue of different capital rules, which makes a homogeneous application of the Basel II Capital Accord [63] and high-level principles [54] an issue with growing importance.

Emerging market observers see a practical evolution towards the full Basel II implementation in a gradual and flexible approach. A first priority is the strengthening of banking supervision compliant with the BCP. Next, the review process is improved as well as disclosure quality. Then, the first pillar is implemented, where due to lack of external ratings, supervisors set up a system of reference ratings, that are used in between the standardized and IRB approach [399]. The actual implementation of the IRB approach and advanced operational risk measures are considered as the final steps.

The implementation of Basel II in emerging markets is an important goal, but the timing depends on the necessary pre-conditions of supervisory resources, legislation, regulation, data and technology availability, such that more advanced issues of Basel II will be implemented on a transitional basis. As in other regions, the improvement of risk management practices is expected to be a main contribution to financial stability.

#### **6.7.4 Impact for creditors**

The impact of the Basel II capital requirements for banks depends on their portfolio composition and the chosen regulatory approach, as discussed in section 6.7.4.1. The changes in the bank's risk management are discussed in section 6.7.4.3. The use test and RAROC will make the pricing more risk sensitive, as explained in section 6.7.4.2. Implementation costs are reviewed in section 6.7.4.4.

##### **6.7.4.1 Impact per type of institution**

Banks with a strong rating will benefit themselves from reduced capital requirements and hence lower funding costs. As size is an important driver for ratings [488], large universal banks will see their funding costs reduced. Smaller banks and/or banks in OECD countries with weaker ratings may see their funding cost increased.

##### **Universal commercial bank**

For universal commercial banks, the change in capital requirements depends on their portfolio composition. Banks with a large amount of retail exposures will see their capital requirements reducing. These reductions decrease when the amount of firm and especially bank and sovereign exposures increases. Large banks will benefit from scale effects when implementing IRBA and AMA. High-quality portfolios will be subject to a lower risk weight.

##### **Retail bank**

Retail banks and building societies will see the largest capital reduction, because of the much lower risk weights for the retail asset class. The capital profits are the highest in countries with low historical losses in the retail sector, i.e. countries that did not observe a real-estate bubble in the (recent) past. However, the concentration risk of smaller retail banks focusing on a particular geographic area, may limit the actual capital gains with respect to the pillar 1 minimum capital requirements. Additional capital in excess of pillar 1 can be required from pillar 2, the regulators or the rating agencies.

The reduced capital requirements will improve returns in the short term. Competition is likely to pass returns to customers over time.

### **Specialist institution**

The capital charge for specialist institutions depends heavily on their portfolio composition. Their specialization typically involves a low operational risk and reduced costs for implementing the advanced IRB approach, where they dispose of high-quality data in their niche market. Such developments can provide the specialist banks a competitive advantage. Some niche players investing in higher-risk products will see capital requirements increasing. Pillar 2 may require higher capital due to risk concentration. Private banks may not need to adopt advanced approaches and, hence, have reduced compliance costs.

Large investment firms are mainly investment banks, brokers and dealers. According to the study in the European Union [400], these firms typically see their capital requirements increase significantly, especially due to the credit risk capital requirements for the trading book. More capital is needed to cover settlement risk as the current 4 days grace period for unsettled transactions is no longer applicable. These firms have many very short-term exposures on their trading books (less than 3 months maturity), for which the Basel II Capital Accord provides less capital relief than the current capital requirements. For the sale and repurchase and stock-lending activities, the application of the haircuts to the supplied collateral will increase capital requirements as well. In addition to credit risk requirements, most firms intend to apply the basic indicator approach, which is perceived to be calibrated for banks rather than investment firms. Smaller investment firms like agency firms, brokers and asset managers see a similar evolution, with operational risk charges being especially important. These firms can be subject to a “limited license” agreement, which would exclude them from changes in pillar 1 requirements. Nevertheless, pillar 2 requirements are expected to be an incentive for improved risk management. For more details and recent evolutions on the impact on investment firms, the reader is referred to the BCBS and IOSCO.

#### **6.7.4.2 Impact on pricing**

The changes in the capital requirement will also impact the pricing of the credits. The credit rates will become more risk sensitive under the new capital accord. The use test will require banks to apply the Basel II risk assessments

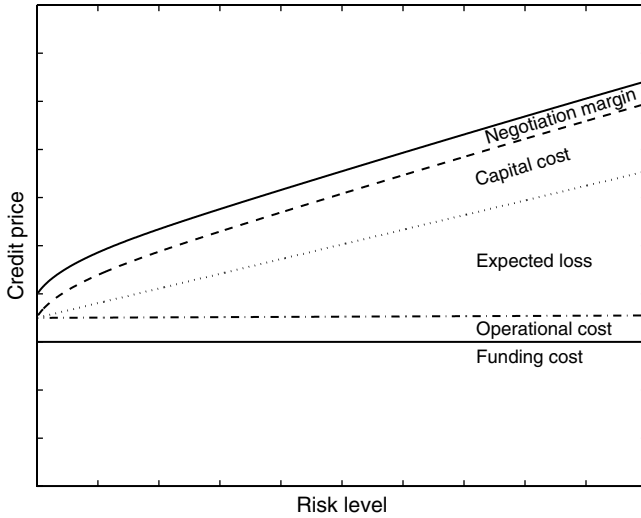

**Fig. 6.11** The bank's perspective of the credit price. The funding cost is the interest rate the bank pays to borrow money on the financial market. Operational costs cover wages, rent, and IT systems. The expected loss is the average loss incurred for a given risk level. It increases linearly with the risk level. The capital cost pays the capital that is required by the bank to cover unexpected losses. The negotiation margin is the additional margin that the bank takes. In highly competitive markets, the negotiation margin can be negative.

in daily use and credit decisions. Many regulators will ask for the relation between the pricing and the risk.

Within the RAROC methodology, it is easily understood that the pricing becomes more risk sensitive. By reversing eqn 5.52, one obtains that

$$\text{Credit Rate} = \text{RAROC} \times \text{Economic capital} + \text{Costs} + \text{EL} \pm \text{Other.}$$

Given a fixed target RAROC, the risk-sensitive elements expected loss (EL) and capital cost ( $\text{RAROC} \times \text{Economic capital}$ ) make the credit rate much more risk sensitive. Note that the risk sensitivity decreases with lower RAROC targets. A typical price curve as a function of the risk is reported in Fig. 6.11, where the negotiation margin is chosen as an additional, other component of the credit price.

The increased focus on the use of Basel II risk assessments and the increased risk sensitivity, are strong drivers for a more risk-sensitive pricing policy. Of course, the pricing policy depends not only on the risk factors. In markets with strong competition, other elements like the bank's commercial strategy and the price elasticity of the customers will determine the pricing in many cases.

Benefits and losses due to reductions and increases of capital requirements will be shared by customers and banks. In markets with strong competition, it is more likely that a larger portion of the benefits is passed to the customers, while in markets with low competition, it is easier for banks to retain the gains. In markets where there is already a very strong competition and margins are small, reduced capital requirements are expected to bring margins back at a normal level. When there are important capital reductions, the disintermediation may be stopped and can even be reversed, because bank lending prices become attractive again compared to bond issues.

#### **6.7.4.3 Impact on risk management**

The Basel II implementation catalyzes strong improvements in credit and operational risk management. Especially for banks that apply the IRB approaches, banks need to develop internal rating systems and internal rating processes to assess the risk of their customers.

Internal IT systems are required to support internal rating systems. Based upon historical data, a risk experience is collected and formalized in internal rating systems. These rating systems support the internal rating processes that analyze at least once a year the risk of the bank's customers. These ratings become more important in the decisions in the organization and are subject to higher quality standards.

For operational risk, an important improvement is the increased sensitivity of senior management to the topic. It is not only required to measure the losses and frequencies of the events incurred in the organization, but also to manage the risk and take the necessary actions to avoid big risk events.

Pillar 2 requirements will further enhance risk management by covering new topics like concentration risk and correlations between different risk categories. These evolutions will make economic capital measures more important.

Risk departments will become more important in the organization:

1. The new tools allow the organization to make better informed investment decisions on transaction and portfolio level.
2. The risk reporting towards senior management has gained a lot of importance.
3. Risk departments evolve towards the function of a strategic advisor on risk matters for the organization.

Some of the reporting tasks will overlap with the financial reporting of the finance department: the input from the risk department is required for risk-based financial reporting. In some organizations, risk and finance departments will be joined in one division.

#### 6.7.4.4 Implementation costs

The implementation costs range widely across banks and depend on the portfolio size and diversification, the sophistication of the risk management and the level of IT implementation. The estimates in [400] indicate that banks have spent (pre-tax) between 0.05–0.10% of their total assets per year during 2002–2006. Larger banks tend to have economy of scale profits, but also have much more complex IT implementations. As mentioned above, about 40% of the budget is spent on data acquisition, management and archiving; 20–25% is spent on IT systems and the remaining part covers personnel costs.

Note that these investments enhance the bank's risk management and risk reporting. In turn, these developments will reduce losses and allow optimization of the bank's investments.

#### 6.7.5 Impact for borrowers

The practical impact for a borrower depends on the regulatory asset class and the risk profile of its issues (PD, LGD, EAD). Impacts are observed between asset classes and within asset classes:

**Intermarket impact:** Risky asset classes will become less attractive in terms of regulatory capital consumption. Exposure to such asset classes will be rationed and/or credit rates will increase. Across different asset classes, those borrowers, for whom the capital requirements are reduced, are likely to gain. For a whole asset class, the capital requirements depend on the average risk levels PD, LGD and EAD, and the regulatory capital rules discussed in Table 6.6 and in section 5.7.

**Intramarket impact:** Within an asset class, the less risky borrowers will benefit from the Basel II Capital Accord, while the more risky counterparts and products will observe more difficult funding and higher credit rates. Within an asset class, the regulatory capital formulae are determined and the differentiation is made by the risk factors PD, LGD and/or EAD. Low-risk products (e.g., with collateral) will benefit. For simple approaches that depend on external credit assessments, the availability of external

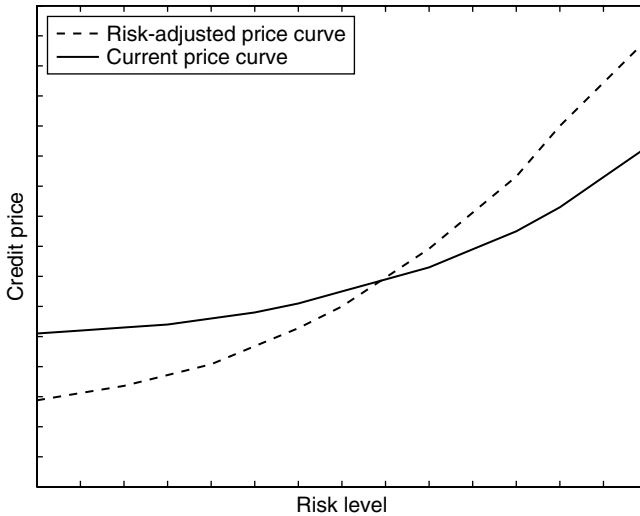

**Fig. 6.12** With Basel II, the pricing of credits will become more risk sensitive. For low-risk counterparts and products, prices tend to decrease, while for higher risk a higher price will be paid. Increased risk sensitivity results from the risk-sensitive Basel II requirements, RAROC pricing tools, the use test requirement and increasing bank profitability requirements.

ratings has an important impact on individual capital requirements. This is especially the case for the foundation approach for banks and firms and for securitization deals.

Generally, pricing will become more risk sensitive as illustrated in Fig. 6.12. Note, however, that the pricing does not depend only on the regulatory capital calculations and “technical” RAROC calculations. Market competition will determine the commercial margins.

In addition to changes in credit pricing and spreads, banks will also require more frequent disclosure of their firm customers within the annual re-rating process. A poor disclosure quality is likely to be interpreted as a sign of decreasing credit quality, also because Basel II requires conservative assumptions to cope with poor data quality. A lower credit quality assessment typically implies a higher rate, as indicated in Fig. 6.12.

Amongst those asset classes that will see the capital requirements reduce, the most important are retail (especially mortgages), small and medium enterprises and large firms. On average, these asset classes are situated more on the left-hand side of Fig. 6.12. Banks, especially lower-rated banks or banks in lower-rated countries, and equity investments will be higher risk

weighted. On average, these asset classes are situated more on the right-hand side of Fig. 6.12.

In the next sections, the impact for the different asset classes is discussed. Note that the impact for banks has already been discussed extensively above.

### 6.7.5.1 Sovereigns

The impact on the sovereign asset class has been discussed above in section 6.7.2. It is important to recall that investments in lower-rated OECD countries will require more capital and a higher pricing. Higher-rated non-OECD countries will see their pricing improve. In some emerging countries, concerns have been raised on possible credit-rationing actions resulting from increased risk weight and risk concentration limits.

In addition to the sovereigns, some other entities like national banks and public sector entities fall in this category (Table 6.5). An important element in their capital requirements is that the Basel II regulation offers significant flexibility to local regulators. Therefore, the capital requirement and pricing of credits to these entities may depend on the risk perception and rules set by local regulators and vary across different countries and economic zones.

### 6.7.5.2 Retail

Within the retail segment, the same general tendencies as illustrated in Fig. 6.12 will hold. In general, the asset class will benefit, but higher-risk counterparts and products will be subject to higher capital requirements and pricing. Within the retail segment, the differences between the different products remain important. As it is very likely that banks moving to the IRB approach will benefit from lower capital requirements, IRB banks will have a competitive advantage.

Because it is unlikely that RAROC methodologies will be applied on a customer level in the retail activities, the risk sensitivity can be less than in other asset classes. In markets with high competition, commercial motivations to sell other financial services may lower the risk sensitivity. On the other hand, the increased sophistication of the credit risk models will make it easier for banks to identify weak customers, which may find it much more difficult to have access to cheap credits.

### 6.7.5.3 Firms

Whereas firms are likely to benefit in general in Basel II, lower-rated firms will see their risk weight increase, as is the case for firms rated below B+



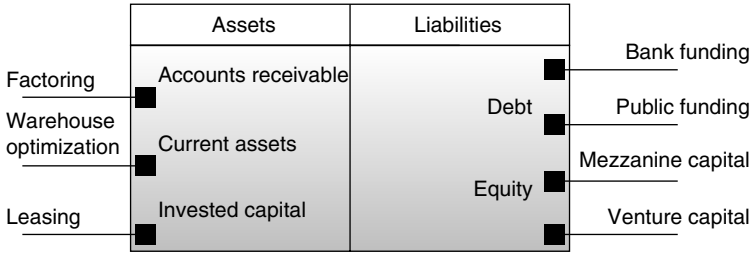

**Fig. 6.13** The funding and funding needs of a (small) firm can be optimized on both the active and passive side. Financial products like leasing and factoring reduce the assets and, hence, the need for credit. On the asset side, alternatives for bank funding are given. Bank funding is probably the main funding for small firms and can be split into collateralized and uncollateralized funding. For larger firms, funding via the bond market can be an interesting alternative as well. The optimization of the balance sheet and funding costs involves the choice between various financial products (leasing, factoring, funding, venture capital) and the operational efficiency of the firm [171].

in the standardized approach (Table 6.6). Concerning the issuer rating, this is not easily changed in the short term. Other capital drivers like LGD and EAD can be influenced by choosing the product type, e.g., a firm can choose a collateralized bullet loan instead of an unsecured revolving credit. Because of the increased risk sensitivity, funding costs will be optimized by various products. Consider Fig. 6.13 with the essentials of a firm balance sheet. Both assets and liabilities side are in balance, which means that one can control the cost of funding either by the choice of debt instruments or by limiting the amount of assets. Indeed, for a fixed equity, a limited amount of assets reduces the debt. A lean balance sheet can be obtained on the asset side by [171]:

**Factoring:** The sale of outstanding receivables to a factoring company allows the firm to get invoices paid earlier and more reliably, providing protection against the default of the firm’s customers. The exchange is not for free, the factoring companies charge a fee or premium by taking into account a discount on the amount outstanding. A minor disadvantage may be that the relation with your customer changes when he is addressed by the factoring company. Factoring is especially useful for firms with low liquidity and important amounts receivable, especially when the customers are better rated than the firm itself.

**Warehouse optimization :** Inventories are financed by either debt or equity. By decreasing the amount of inventories, funding needs are reduced and

the balance sheet structure is improved with a lower leverage. Such warehouse optimization is interesting for firms with a large stock in goods. More generally, efficiency gains are always interesting, but may require a lot of effort.

**Leasing:** Leasing is a hybrid form between renting and purchasing that is not only available for cars, but for an increasing number of equipments. It allows high investment costs to be avoided and lowers the amount of investment capital on the active side of the balance sheet. A disadvantage is that it can be more expensive than a bank loan and one does not fully own the equipment. In some countries, leasing benefits from tax advantages.

On the liability side, there exist alternatives for the plain-vanilla unsecured loan:

**Public funding:** In some countries, public funding is available through government institutions and/or semigovernment banks. It is used to stimulate the local economy and is therefore often cheaper than bank loans, but eligibility criteria can restrict this funding for mainly small firms and start-ups. The approval of such loan requests can be lengthy and require additional compliance costs.

**Collateralized funding:** Collateral has an important impact on the LGD, which in turn is very important in the capital requirement. In the short term, it is often easier to impact the risk of the issue by reducing the LGD with collateral than by improving the firm's PD. Complementary to collateralized funding, the risk (and price) of a credit can be reduced by guarantees, e.g., from a strong mother company.

**Mezzanine financing:** This is a hybrid form of capital that combines elements of debt and equity, an example being convertible bonds. The price of the embedded options may reduce the interest rate charged or can be higher than a classical loan, but can offer more repayment flexibility. Semi equity can be interesting when there are balance sheet or capitalization restrictions.

**Venture capital:** Private equity and venture capital firms invest in the firm and take part of the firm's equity. It allows firms to improve their leverage and their rating. In return for the equity, the venture capital firms may also play a role in the management and offer their know-how. On the other hand, the founders of the firm may need to give up part of their autonomous decision making. Venture capital is especially interesting for small companies with high growth perspectives.

When pricing is not very risk sensitive, the incentive for tailored and more complex products is rather limited. The increased risk sensitivity catalyzed by Basel II will increase the importance of more complex, structured products.

With the firm asset class, small firms receive a beneficial risk weight when both PD, LGD and EAD are equal due to a lower asset correlation as indicated in eqn 5.42. Small firms in the retail asset class have even a lower risk weight.

#### **6.7.5.4 Equities**

Because the risk weight for non-consolidated investments in other companies can increase from 100% (Basel I) to 300% (Basel II, simple risk weight method, section 6.3.1.2.B.3), banks will continue to reduce equity holding. Risk weights for equities are much higher in the IRB approach than in the standardized approach. Moreover, banks with a high-quality equity portfolio are penalized by the simple risk weight method and will opt for the PD/LGD or the internal models approach. Transitional arrangements in the 10-year grandfathering period will allow banks to adjust their positioning towards equity holdings.

In Europe, banks have an important role to provide funding for the European private equity and venture capital industry with on average 25% of the funds raised. The risk weights in the Third Consultation Paper (CP3, 6.1) have been generally considered as too excessive, especially for well-diversified portfolios. Significant concerns have been raised by the venture capital industry that the new capital accord would cause banks to limit such equity investments and result in a general reduction of equity financing of European countries, with a subsequent potentially negative impact on small and medium-size companies. The Basel II Capital Accord requirements ranging from 24% to 32% of the total investment have been reduced to a range of 13% to 17% in the European Capital Adequacy Directive III, on condition that the portfolio is sufficiently diversified.

Note that convertibles are not yet discussed thoroughly in the Basel II regulation. Some regulators tend to consider it as debt as long as there is no intention for a conversion to equity; otherwise, it is considered as equity. Some regulators apply a more conservative approach and treat the convertible debt as equity when a conversion is possible within a year or the premium of the convertible is sufficiently low.

### 6.7.5.5 Securitization

The Basel II impact on securitization exposures is twofold. First, the different risk weighting of underlying assets will influence which assets will be influenced first. Secondly, risk weights for securitization have become much more risk sensitive (Table 6.16), such that the impact depends mainly on the tranche seniority. Because the lower-rated tranches and the first loss/equity tranche have very high risk weights and even require capital, it is likely that banks prefer to sell these pieces. Low-risk tranches generally require less economic capital than the Basel I Capital Accord. In Basel II, the lower regulatory risk weight is applicable when they are externally rated. It is expected that banks will target more the higher-rated tranches of the securitization market [242].

Because the Basel II capital rules give risk weights different from the Basel I rules, the structuring of the new deals will be tuned towards the new capital requirements. For example, because higher risk weights will be applicable to non-investment-grade tranches, it is expected that such tranches will become more limited in total amount.

Balance-sheet optimization via the reduction of capital requirements is an important motivation for securitization deals. For mortgage-backed securities (MBS), residential real estate is risk weighted 35%, while commercial real estate is risk weighted 50% or 100% in the Basel II standardized approach (section 6.3.1.1.A.4). This explains why commercial MBS (CMBS) have gained popularity during the past years, while residential MBS (RMBS) and other “true sales” operations are interesting because of the attractive funding. Credit card ABS structures have been reported to benefit from similar capital incentives [242].

The increased risk sensitivity for firms means that the risk weight for well-rated firms reduces capital consumption on these assets such that securitization for capital relief is no longer very efficient [81]. Instead, banks will opt to securitize lower-rated firm issues. For the same reason, the lowest tranches of securitization deals are also good material for banks to resecuritize to reduce capital consumption. Resecuritization transactions like CDOs of MBSs, ABSs and CDOs gained importance recently. Where typically originators kept the first loss pieces or equity tranches, originating banks will consider the sale of these products to specialized investors.

Covered bonds are not securitization products, but are quite similar, the main difference being that the collateral remains on the emitting bank's balance sheet instead of putting it in a SPV. Covered bonds are especially

important in Europe. Covered bonds have received a specific treatment in the European Capital Requirements Directive to ensure that the risk weight is more or less in line with the risk profile of covered bonds and related products.

### **6.7.6 Impact on the economy**

Basel II introduces an important change in the regulation of the banking industry. These changes will impact the economy as a whole. In the last section of this book, the possible procyclical effects of the next capital rules are discussed. Then, the global macroeconomic impact is reviewed. The general impact of improved risk management techniques for the economy is discussed at the end.

An important question that has been raised by economists and businessmen is whether the new capital will exacerbate the procyclicality in loans. Procyclicality refers to the observed effect that the amount of bank loans increases during business-cycle expansions and reduces during downturns. These effects have already been observed in the past and concerns were raised that the increased risk sensitivity of the capital accord would cause procyclicality in the lending behavior. Since the initial propositions of the capital accord (Table 6.1), counteractive measures have been taken to limit such effects: the risk sensitivity of the capital formulae has been reduced and the risk parameters are estimated as long-term<sup>99</sup> averages, which makes the calibrated parameter values less sensitive to overoptimism, avoiding upward calibration during downturns. Note that in some countries, dynamic provisioning is already actively encouraged such that the possible loss over the whole life of the loan (and business cycle) is taken into account in the provision. In addition, pillar 2 stress tests will reveal changes in capital requirements during downturns. Because of these stress tests, banks will operate above the minimum capital requirement during expansions and have a capital buffer for recessions. With these measures, capital requirements are unlikely to become binding in downturns such that regulatory constraints would trigger reductions in the lending behavior.

The qualitative impact studies indicate that the capital requirements will reduce for exposures to firms and retail customers. The benefits are the

<sup>99</sup> Recall that some risk parameters like LGD and EAD are required to be estimated during downturn periods in the case when these parameters are highly sensitive to downturn macroeconomic conditions.

highest for low-risk exposures as discussed in section 6.7.5 and visualized in Fig. 6.12. Here, the impact on the global economy is discussed. On a macroeconomic perspective, these benefits can be either:

1. Retained by banks that use the reduced capital cost for the higher-profit generation, while deposit and lending rates remain unchanged,
2. Used to increase deposit rates and pass the capital savings to savers,
3. Passed to the retail and/or firm borrowers by decreasing lending rates.

Which of these scenarios will occur depends not only on the bank's strategy, but also on the market profitability, bank efficiency, customer behavior, and market competitiveness. Benefits will likely be distributed differently towards different customer types. Competition tends to be higher in the firm segment than in the retail segment. The pricing in the retail segment has historically benefitted from customer inertia, but recent reports indicate that customers become more likely to switch finance service suppliers such that competition will also increase there. Of course, the benefits will be passed on to the wider economy in a second step. The impact on the European economy was analyzed via a global macroeconomic model<sup>100</sup> used for policy examination. With this model, the following scenarios were analyzed [400]:

**Lower borrowing costs for companies:** When the benefits of the capital reduction are passed fully to a reduction in borrowing costs for companies, a positive supply-side shock would be created. The reduction in borrowing cost for producers increases the Gross Domestic Product (GDP), which in turn results in a permanent improvement in productive potential in the EU. In the long run, the average output of the EU economy would increase by 0.07% on a yearly basis. The main effect is the boost in capital stock by which labor productivity is increased, the impact on employment and inflation is limited. Industry sectors with high capital costs benefit most and in expanding sectors, the reduced capital stock will stimulate investments.

<sup>100</sup> The concerned model is the NiGEM model [374] from the National Institute for Economic and Social Research (NIESR), UK. It is an estimated model that uses a "New-Keynesian" framework in which economic agents are presumed to be forward looking, but the adjustment to external events is slowed down by nominal rigidities. All countries are modelled separately, but their economies are linked via trade, competition and financial markets. The model contains equations for trade, financial markets, wealth and asset accumulation, consumption and personal income, production, labor markets, fiscal policy rules and monetary policy rules.

**Lower borrowing costs to retail consumers:** When the capital reductions are used to reduce credit rates for retail loans, there is no net change on the overall output of the EU economy. There is an increase on the demand, that causes only a secondary effect on the supply side. Note that an increase in demand without an effect on supply will result into inflationary pressure such that interest rates will be increased by central banks, impacting both consumers and companies. As a global result, consumption improves a little, while investment reduces a little such that the total long-run effect on output is zero.

**Increased bank profitability:** When the capital reductions are used to increase bank profitabilities, the impact of Basel II is passed to consumers in the long run via increased dividend payments. Like in the previous scenario, the slight consumption increment from dividends is offset by the reduction in investments.

The main conclusion of the overall effect on the global economy is slightly positive [400]. A small effect would occur when the Basel II benefits are passed to companies, there is no macroeconomic effect in the last two scenarios where benefits are passed to consumers or retained by banks.

In addition to the macroeconomic impact on interest rates, Basel II also aims to improve the stability of the banking system. A stable banking system enables a stable economy and creates the conditions under which the growth potential of the economy can be realized. As mentioned in Chapter 1, bank failures reduce financial efficiency and cause local reduction in economic growth [392]. In addition, a stable banking environment also reduces price volatility of loans and services, which makes investment plans easier. Uncertainty in the economy as a whole is reduced by a more stable and strong banking system. With reduced bank failure, the continuity of the relations between the bank and borrowers is improved. Such long-term relations enhance information for risk assessment and granting, such that borrowers will get loans approved more easily. In macroeconomic adverse times with bank failures, it is easier to get a loan at the customer's current bank. Improved confidence in the banking system is also important for long-term contracts.

A main objective of Basel II is to improve risk management techniques through the capital incentives for more advanced approaches. The improved risk management will allow better identification of the

risks and allocation of capital resources. A more efficient allocation of resources is generally a catalyst for a better economy. With Basel II, the scarce capital amount is more efficiently allocated between competing loan applicants with various risk profiles. As indicated by Fig. 6.12, high-quality loans will stop sponsoring low-quality loans. The bank capital is better aligned with their risk profile. In [432] it is already noted that the 2001 crisis did have less impact on the banking system than previous crises, partially because of improvement in risk management and the resulting better balance sheets.

## 6.8 Future evolution

Basel II was made possible by the advances in bank risk management techniques. The new capital accord allowed banks to rely upon their internal credit expertise and stimulated banks to develop quantitative risk management techniques. In general, these developments will be beneficial for banks and stakeholders, allocating bank capital more in line with risk profiles.

Basel II aims to be an evolutionary framework, as is explicitly stated by the BCBS in section 18 in the beginning of the ICCMCS [63] (see text box). New evolutions in risk management and especially in pillar 2 will clear the way for more advanced internal-capital-based regulation, where not only the risk parameters, but also the portfolio parameters are tuned on the bank's portfolio. Advanced banks with already advanced internal portfolio models will prefer to use one system instead of parallel economic and regulatory capital systems. Credit, market and other risk types become more and more integrated as well as new financial products. Regulation will evolve further with ongoing innovation and developments in financial products, financial engineering and risk management techniques, some of which will themselves use results from the current Basel II developments.

Regulatory pressure has been a main incentive for banks to improve their risk management with available state-of-the-art techniques. In particular IRBA advanced banks have made important investments to improve their risk management strategies. With the enhanced tools, the risk management departments will see that in the task list of section 1.6, risk quantification, regulatory solvency, and strategic advice will become more important additional tasks on top of pure risk analysis:



**Basel II aims to be an evolutionary framework (section 18 [63])**

The Committee also seeks to continue to engage the banking industry in a discussion of prevailing risk management practices, including those practices aiming to produce quantified measures of risk and economic capital. Over the last decade, a number of banking organizations have invested resources in modeling the credit risk arising from their significant business operations. Such models are intended to assist banks in quantifying, aggregating and managing credit risk across geographic and product lines. While the Framework presented in this document stops short of allowing the results of such credit risk models to be used for regulatory capital purposes, the Committee recognizes the importance of continued active dialogue regarding both the performance of such models and their comparability across banks. Moreover, the Committee believes that a successful implementation of the revised Framework will provide banks and supervisors with critical experience necessary to address such challenges. The Committee understands that the IRB approach represents a point on the continuum between purely regulatory measures of credit risk and an approach that builds more fully on internal credit risk models. In principle, further movements along that continuum are foreseeable, subject to an ability to address adequately concerns about reliability, comparability, validation, and competitive equity. In the meantime, the Committee believes that additional attention to the results of internal credit risk models in the supervisory review process and in banks' disclosures will be highly beneficial for the accumulation of information on the relevant issues.

**Risk analysis, pricing and investment decisions:** The core business of risk management surely remains the defensive role of analyzing the risk of investments, and better informed decision making. With a better equipped risk management, better investment decisions can be taken when the business is correctly informed. Better investment decisions allow high risk banks to reduce losses. Enhanced tools will give low-risk banks the capacity to increase their risk profile as better decisions can be made. The challenge for the risk department is to create an increased risk awareness in the mindset and operations of the business and create an investment culture at all levels by embedding the enhanced risk measures in the organization.

**Risk quantification:** With Basel II, the attention of risk management has moved towards risk measurement and risk quantification. Advanced techniques discussed in Chapter 4 and in book II are used to build decision-support systems to rank risk objectively and to calibrate the risk levels. These systems will be used more and more in the organization, not only for Basel II purposes.

Like risk management is an ongoing activity, also risk quantification becomes an ongoing task, not only because of backtesting requirements, but also to maintain the quality of the existing models and calibrated risk parameters.

**Risk monitoring and reporting:** A continuous evaluation of the risk of its counterparts is required by Basel II, e.g., all credit risk counterparts need to be rerated at least once a year by IRB banks. The yearly re-rating exercise will require a significant effort from risk officers. Semiautomated model based rerating analyses for low-risk and low-exposure counterparts can allow risk officers to focus on the risky and high-exposure counterparts. The investment in IT systems will allow banks to report more frequently the risk profile of their different portfolios and to analyze rapidly the impact of a financial distress of a major financial conglomerate. The risk management department will report more frequently the risk profile and key risk numbers like capital ratios, expected loss, earnings-at-risk and value-at-risk to the senior management.

**Solvency:** Additional roles of regulatory compliance and risk reporting (e.g., pillar 3) will consume important parts of the risk budget. Both risk management and finance departments will co-operate on financial and regulatory reporting.

There will be pressure to automate reporting and compliance tasks to allow risk professionals to focus on their core business and create added value. A pre-requisite for automation is the availability of an efficient data infrastructure reducing the need for data cleaning. It will be a major challenge for banks to change the risk focus from regulatory implementation and compliance to added value generation, creativity and innovation.

Many risk departments have been struggling in recent years to meet the increasing demands of Basel II. The important changes in responsibilities will require a new organization structure that allows value and information creation and reduces the human workload on information passing and reporting tasks.

**Strategic partner:** In its role of strategic partner, the risk management will provide the business with advice on the risk level and diversification benefits of potential new products and target customer groups. Point-in-time techniques, reactive risk scores and stress-testing exercises will warn the organization about the likelihood and impact of adverse changes in the market circumstances and will allow the bank to take pro-active measures. The role of the risk management should not be limited to Basel II tail risk to avoid events that may happen with a very low probability of 0.1%. Earnings at risk scenarios assume a mild stress that may occur once every 5 or 10 years; their results will inform the senior management about the impact on the bank's capital and profitability in such adverse conditions.

The increased availability of advanced risk analysis, measurement, monitoring and management tools allows the risk management not only to efficiently safeguard the bank's risk profile, but also to take the role of a strategic partner in the bank's commercial development plan. These evolutions will give the risk department an important and strategic position in the organization.

The risk management departments now have an important responsibility to secure the investments by passing the benefits to the whole organization. All the current and future evolutions will make the risk universe a challenging and strategic area in the future for researchers, risk officers and – last but not least – financial institutions themselves.

# References

---

- [1] Acerbi, C. and Tasche, D. (2002). On the coherence of expected shortfall. *Journal of Banking and Finance*, **26**(7), 1487–1503.
- [2] Adelson, M.H. (2003). CDO and ABS underperformance: a correlation story. *Journal of Fixed Income*, **13**(3), 53–63.
- [3] Aguais, S.D., Forest, L.R. Jr., Wong, E.Y.L., and Diaz-Ledezma, D. (2004). Point in time versus through the cycle ratings. In *The Basel handbook: a guide for financial practitioners* (ed. M. Ong), Risk Books, London, UK, pp. 183–209.
- [4] Akerlof, G. (1970). The market for ‘lemons’: Quality uncertainty and the market mechanism. *Quarterly Journal of Economics*, **84**, 488–500.
- [5] Alderweireld, T., Garcia, J., and Leonard, L. (2006). A practical operational risk scenario analysis quantification. *Risk*, **19**(2), 93–95.
- [6] Alexander, C. (ed.) (2003). *Operational risk: regulation, analysis and management*. Financial Times, Prentice Hall, NJ.
- [7] Allen, F. and Gale, D. (1994). *Financial innovation and risk sharing*. MIT Press, Cambridge, MA.
- [8] Allen, F. and Santomero, A.M. (1998). The theory of financial intermediation. *Journal of Banking and Finance*, **21**, 1461–1485.
- [9] Allen, L. and Saunders, A. (2004). Incorporating systemic influences into risk measurements: a survey of the literature. *Journal of Financial Services Research*, **26**(2), 161–191.
- [10] Allen, S. (2003). *Financial risk management*. John Wiley & Sons, Hoboken, New Jersey.
- [11] Altman, A., Resti, A., and Sironi, A. (2005). The PD/LGD link: Empirical evidence from the bond market. In *Recovery risk: the next challenge in credit risk management* (ed. A. Altman, A. Resti, and A. Sironi), Risk Books, London, UK, pp. 217–233.
- [12] Altman, E.I. (1968). Financial ratios, discriminant analysis and the prediction of corporate bankruptcy. *Journal of Finance*, **23**, 589–609.

- [13] Altman, E.I. (1989). Measuring corporate bond mortality and performance. *Journal of Finance*, **44**(4), 909–922.
- [14] Altman, E.I. (1993). *Corporate financial distress and bankruptcy: a complete guide to predicting and avoiding distress and profiting from bankruptcy*. Wiley finance edition, Hoboken, New Jersey.
- [15] Altman, E.I., Haldeman, R.G., and Narayanan, P. (1977). Zeta analysis: A new model to identify bankruptcy risk of corporations. *Journal of Banking and Finance*, **1**, 29–54.
- [16] Altman, E., Resti, A., and Sironi, A. (ed.) (2005). *Recovery risk*. Risk Books, London.
- [17] Altman, E.I. and Rijken, H.A. (2004). How rating agencies achieve rating stability. *Journal of Banking & Finance*, **28**, 2679–2714.
- [18] Altman, E.I. and Rijken, H.A. (2006). A point-in-time perspective on through-the-cycle ratings. *Financial Analysts Journal*, **62**(1), 54–70.
- [19] Andersen, T., Bollerslev, T., Diebold, F.X., and Labys, P. (2001). The distribution of realized exchange rate volatility. *Journal of the American Statistical Association*, **96**, 42–55.
- [20] Andreau, J. and Lloyd, J. (1999). *Banking and business in the roman world (Key themes in ancient history)*. Cambridge University Press, Cambridge.
- [21] Anhamm, C., Winkler, S., Parhar, H., Kini, D., and Nilsson, M. (2006). *Liquid covered bonds the expansion continues* (6th edn). ABN-AMRO.
- [22] Araten, M. and Jacobs, M. (2001, May). Loan equivalents for revolving credits and advised lines. *The RMA Journal*, 34–39.
- [23] Araten, M., Jacobs, M., and Varshney, P. (2004, May). Measuring LGD on commercial loans: an 18-year internal study. *The RMA Journal*, 28–35.
- [24] Araten, M., Jacobs, M. Jr., Varshney, P., and Pellegrino, C.R. (2004). An internal ratings migration study. *The RMA Journal*, 92–97.
- [25] Artzner, P.F., Delbaen, J.-F., and Heath, D. (1999). Coherent measures of risk. *Mathematical Finance*, **9**, 1487–1503.
- [26] Asarnow, E. and Edwards, D. (1995). Measuring loss on defaulted bank loans. a 24-year-study. *Journal of Commercial Lending*, **77**(7), 11–23.
- [27] Asarnow, E. and Marker, J. (1995). Historical performance of the US corporate loan market: 1988–1993. *The Journal of Commercial Lending*, **77**(2), 13–32.

- [28] Atiya, A.F. (2001). Bankruptcy prediction for credit risk using neural networks: A survey and new results. *IEEE Transactions on Neural Networks*, **12**(4), 929–935.
- [29] Baesens, B., Mues, C., Van Gestel, T., and Vant (2005). Neural network survival analysis for personal loan data. *Journal of Operation Research Society*, **59**(9), 1089–1098.
- [30] Baesens, B., Setiono, R., Mues, C., and Vanthienen, J. (2003). Using neural network rule extraction and decision tables for credit-risk evaluation. *Management Science*, **49**(3), 312–329.
- [31] Baesens, B., Van Gestel, T., Viaene, S., Stepanova, M., Suykens, J.A.K., and Vanthienen, J. (2003). Benchmarking state of the art classification algorithms for credit scoring. *Journal of the Operational Research Society*, **54**(6), 627–635.
- [32] Baesens, B., Viaene, S., Van den Poel, D., Vanthienen, J., and Dedene, G. (2002). Bayesian neural network learning for repeat purchase modelling in direct marketing. *European Journal of Operational Research*, **138**(1), 191–211.
- [33] Baesens, B., Viaene, S., Van den Poel, D., Vanthienen, J., and Dedene, G. (2002). Using Bayesian neural networks for repeat purchase modelling in direct marketing. *European Journal of Operational Research*, **138**(1), 191–211.
- [34] Baestaens, D.E. (1999). Credit risk modeling strategies: the road to serfdom? *International Journal of Intelligent Systems in Accounting, Finance and Management*, **8**, 225–235.
- [35] Baker, H.K. and Mansi, S.A (2002). Assessing credit agencies by bond issuers and institutional investors. *Journal of Business Finance and Accounting*, **29**(9,10), 1367–1398.
- [36] Balkan, E. (1992). Political instability, country risk and probability of default. *Applied Economics*, **24**, 999–1008.
- [37] Balthazar, L. (2006). *From Basel 1 to Basel 3: The integration of state-of-the-art risk modeling in banking regulation*. Palgrave, NY.
- [38] Banasik, J., Crook, J.N., and Thomas, L. (1996). Does scoring a subpopulation make a difference? *International Review of Retail, Distribution and Consumer Research*, **6**, 180–195.
- [39] Banasik, J., Crook, J.N., and Thomas, L.C. (1999). Not if but when will borrowers default. *Journal of the Operational Research Society*, **50**, 1185–1190.
- [40] Barber, B. and Odean, T. (1999, November). The courage of misguided convictions. *Financial Analysts Journal*.

- [41] Barron, M., Clare, A., and Thomas, S. (1997). The effect of bond rating changes and new ratings on UK stock returns. *Journal of Business, Finance and Accounting*, **24**, 497–509.
- [42] Bartlett, F. (2000, February). Secured loan recovery study: The UK experience. Technical report, Fitch IBCA, NY.
- [43] Basel Committee on Banking Supervision (1988, October). Instruments eligible for inclusion in Tier 1 capital. Technical report, Bank for International Settlements, Basel.
- [44] Basel Committee on Banking Supervision (1996, January). Amendment to the capital accord to incorporate market risks. Technical report, Bank for International Settlements, Basel.
- [45] Basel Committee on Banking Supervision (1996). Supervisory framework for the use of ‘backtesting’ in conjunction with the internal models approach to market risk capital requirements. Technical report, Bank for International Settlements, Basel.
- [46] Basel Committee on Banking Supervision (1997, September). Amendment to the capital accord to incorporate market risks. Technical report, Bank for International Settlements, Basel.
- [47] Basel Committee on Banking Supervision (1997). Core principles for effective banking supervision. Technical report, Bank for International Settlements (BIS).
- [48] Basel Committee on Banking Supervision (1998). Enhanced bank transparency. Technical report, Bank for International Settlements (BIS), Basel.
- [49] Basel Committee on Banking Supervision (1998). International Convergence of Capital Measurement and Capital Standards. Technical report, Bank for International Settlements, Basel.
- [50] Basel Committee on Banking Supervision (2000, September). Principles for the management of credit risk. Technical report, Bank for International Settlements, Basel.
- [51] Basel Committee on Banking Supervision (2000). Sound practices for managing liquidity. Technical report, Bank for International Settlements (BIS), Basel.
- [52] Basel Committee on Banking Supervision (2001). Pillar 3 (market discipline), supporting document to the new Basel capital accord. Technical report, Bank for International Settlements (BIS), Basel.
- [53] Basel Committee on Banking Supervision (2001). Principles for the management and supervision of interest rate risk. Technical report, Bank for International Settlements (BIS), Basel.

- [54] Basel Committee on Banking Supervision (2003). High-level principles for the cross-border implementation of the New Accord. Technical report, Bank for International Settlements, Basel.
- [55] Basel Committee on Banking Supervision (2003, February). Sound practices for the management and supervision of operational risk. Technical report, Bank for International Settlements, Basel.
- [56] Basel Committee on Banking Supervision (2004). Bank failures in mature economies. Technical report, Bank for International Settlements, Basel.
- [57] Basel Committee on Banking Supervision (2004, October). An explanatory note on the Basel II IRB risk weight functions. Technical report, Bank for International Settlements, Basel.
- [58] Basel Committee on Banking Supervision (2004). International convergence of capital measurement and capital standards. Technical report, Bank for International Settlements (BIS), Basel.
- [59] Basel Committee on Banking Supervision (2004, July). Principles for the management and supervision of interest rate risk. Technical report, Bank for International Settlements, Basel.
- [60] Basel Committee on Banking Supervision (2005, July). Guidance on paragraph 468 of the framework document. Technical report, Bank for International Settlements, Basel.
- [61] Basel Committee on Banking Supervision (2005). Studies on the validation of internal rating systems. Working paper 14, Bank for International Settlements.
- [62] Basel Committee on Banking Supervision (2005). The Application of Basel II to Trading Activities and the Treatment of Double Default Effects. Technical report, Bank for International Settlements, Basel.
- [63] Basel Committee on Banking Supervision (2006). International Convergence of Capital Measurement and Capital Standards, A Revised Framework. Technical report, Bank for International Settlements, Basel.
- [64] Basel Committee on Banking Supervision (2006, June). Results on the fifth quantitative impact study (QIS5). Technical report, Bank for International Settlements, Basel.
- [65] Basel Committee on Banking Supervision (2007). History of the Basel Committee and its Membership. Technical report, Bank for International Settlements, Basel.



- [66] Baxter, M. and Rennie, A. (1996). *Financial calculus. An introduction to derivative pricing*. Cambridge University Press, Cambridge.
- [67] Beattie, V. and Searle, S. (1992). Bond ratings and inter-rater agreement. *Journal of International Securities Markets*, 167–172.
- [68] Beaver, W.H. (1966). Financial ratios as predictors of failure. *Empirical Research in Accounting Selected Studies, supplement to the Journal of Accounting*, **5**, 71–111.
- [69] Becchetti, L. and Sierra, J. (2002). Bankruptcy risk and productive efficiency in manufacturing firms. *Journal of Banking and Finance*, **27**, 2099–2120.
- [70] Beckmann, C. and Papazoglou, P. (2004). Sicherheitenoptimierung nach Basel II. *Kreditwesen*, **3**, 146–150.
- [71] Bell, J. and Pain, D. (2000, December). Leading indicator models of banking crises: a critical review. *Bank of England Financial Stability Review*, 113–129.
- [72] Berger, A.N. (1998). The efficiency effects of bank mergers and acquisitions: A preliminary look at the 1990s data. In *Bank mergers and acquisitions* (ed. Y. Amihud and G. Miller), Kluwer Academic Publishers Boston, pp. 79–111.
- [73] Berger, A.N., Demsetz, R.S., and Strahan, P.E. (1999). The consolidation of the financial services industry: Causes, consequences and implications for the future. *Journal of Banking & Finance*, **23**, 135–194.
- [74] Berger, A.N., Hancock, D., and Humphrey, D.B. (1993). Bank efficiency derived from the profit function. *Journal of Banking and Finance*, **17**, 317–347.
- [75] Berger, A.N., Herring, R.J., and Szegö, G.P. (1995). The role of capital in financial institutions. *Journal of Banking and Finance*, **19**, 393–430.
- [76] Berger, A.N., Hunter, W.C., and Timme, S.G. (1993). The efficiency of financial institutions: A review and preview of research past, present and future. *Journal of Banking and Finance*, **17**, 221–249.
- [77] Berry, M.J.A. and Linoff, G.S. (2004). *Data mining techniques for marketing, sales and customer relationship management*. Wiley, Hoboken, New Jersey.
- [78] Bessis, J. (2003). *Risk management in banking* (2nd edn). Wiley, Chichester.
- [79] Bhattacharya, S. and Thakor, A.V. (1993). Contemporary banking theory. *Journal of Financial Intermediation*, **3**, 2–50.

- [80] Black, F. and Scholes, M. (1973). The pricing of options and corporate liabilities. *Journal of Political Economy*, **81**, 637–654.
- [81] Blum, C. and Overbeck, L. (2006). *Structured credit portfolio analysis, baskets and CDOs*. Chapman & Hall, USA.
- [82] Blum, C., Overbeck, L., and Wagner, C. (2002). *An introduction to credit risk modeling* (1st edn). CRC Financial Mathematics Series. Chapman & Hall, Boca Raton.
- [83] Blum, M. (1974). Failing company discriminant analysis. *Journal of Accounting Research*, **12**(1), 1–25.
- [84] Bohn, J. and Kealhofer, S. (2001). Portfolio management of default risk. Technical report, KMV.
- [85] Boot, A. and Thakor, A. (1991). Moral hazard and secured lending in an infinitely repeated credit market game. *International Economic Review*, **35**, 899–920.
- [86] Boot, A., Thakor, A., and Udell, G. (1987). Competition, risk neutrality and loan commitments. *Journal of Banking and Finance*, **11**, 449–471.
- [87] Boritz, J.E., Kennedy, D.B., and Albuquerque, A. (1995). Predicting corporate failure using a neural network approach. *International Journal of Intelligent Systems in Accounting, Finance and Management*, **4**(2), 95–111.
- [88] Bostelman, J.T. (2004). *The Sarbanes-Oxley deskbook*. Practising Law Institute.
- [89] Box, G.E.P and Jenkins, G.M. (1970). *Time series analysis, forecasting and control*. Holden-Day, San Francisco.
- [90] Box, G.E.P. and Tidwell, P.W. (1962). Transformations of the independent variables. *Technometrics*, **4**, 531–550.
- [91] Brealey, R.A. and Myers, S.C. (2003). *Principles of corporate finance* (7th edn). McGraw Hill, London.
- [92] Breger, L., Goldberg, L., and Cheyette, O. (2003). Market Implied Ratings. *Risk*, **16**(7), 85–89.
- [93] Breuer, J.B (2004). An exegesis on currency and banking crises. *Journal of Economic Surveys*, **18**(3), 293–320.
- [94] Brockett, P., Cooper, W., Golden, L., and Pitaktong, U. (1994). A neural network method for obtaining an early warning of insurer insolvency. *The Journal of Risk and Insurance*, **6**, 402–424.
- [95] Butler, C. (1999). *Mastering value-at-risk*. Pearson Education Limited, Harlow, Great Britain.

## 490 References

- [96] Buzzell, D.H. (2004). *Principles of banking*. American Bankers Association, Washington, DC.
- [97] Campbell, J.Y., Lo, A.W., and MacKinlay, A.C. (1997). *The econometrics of financial markets*. Princeton University Press, Princeton, New Jersey.
- [98] Canals, J. (1997). *Universal banking: international comparisons and theoretical perspectives*. Clarendon Press, Gloucestershire, UK.
- [99] Cantor, R. (2001, September). Summary guidance for notching secured bonds, subordinated bonds, and preferred stocks of corporate issuers. Technical report, Moody's Global Credit Research.
- [100] Cantor, R., Fons, J., Munves, D., Mann, C., and Viswanathan, J. (2007). An explanation of Market Implied Ratings. Technical report, Moody's Investors Service.
- [101] Cantor, R. and Packer, F. (1995). The credit rating industry. *Journal of Fixed Income*, **5**(3), 10–34.
- [102] Cantor, R. and Packer, F. (1996). Determinants and impact of sovereign credit ratings. *Economic Policy Review*, **2**(2), 37–53. Federal Reserve Bank of New York.
- [103] Cantor, R. and Packer, F. (1997). Differences of opinion and selection bias in the credit rating industry. *Journal of Banking and Finance*, **21**, 1395–1417.
- [104] Caouette, J., Altman, E., and Narayanan, P. (1998). *Managing credit risk: the next great financial challenge*, John Wiley & Sons, Inc., New York.
- [105] Capie, F. and Wood, G.E. (1999). *Banking theory, 1870–1930 (History of banking & finance)*. Routledge, UK.
- [106] Capital Markets Risk Advisors (2001, May). Economic capital survey overview. Technical report.
- [107] Carey, M. (2001). Dimensions of credit risk and their relationship to economic capital requirements. In *Prudential supervision: what works and what doesn't* (ed. F. Mishkin). University of Chicago Press, London.
- [108] Carey, M.S. (2002). A guide to choosing absolute bank capital requirements. *Journal of Banking and Finance*, **26**(5), 929–951.
- [109] Cavanaugh, M. (2003). Credit FAQ: Foreign/local currency and sovereign/nonsovereign rating differentials. Technical report, Standard & Poor's.

- [110] Cecchetti, S.G. (2005). *Money, banking and financial markets*. Irwin Professional Pub.
- [111] Chang, C. (1990). The dynamic structure of optimal debt contracts. *Journal of Economic Theory*, **52**, 68–86.
- [112] Chattopadhyay, S.P. (1997). Neural network approach for assessing country risk for foreign investment. *International Journal of Management*, **14**(2), 159–167.
- [113] Chew, W.H. and Kerr, S.S. (2005). Recovery ratings: a fundamental approach to estimating recovery risk. In *Recovery risk: the next challenge in credit risk management* (ed. A. Altman, A. Resti, and A. Sironi), Risk Books, London, UK, pp. 87–100.
- [114] Cifuentes, A. and O'Connor, G. (1996). The Binomial Expansion Technique applied to CBO/CLO analysis. Special report, Moody's.
- [115] Citron, J.T. and Nickelsburg, G. (1987). Country risk and political instability. *Journal of Development Economics*, **25**, 385–392.
- [116] Collin-Dufresne, P., Goldstein, R.S., and Martin, J.S. (2001). The determinants of credit spread changes. *The Journal of Finance*, **56**(6), 2177–2207.
- [117] Committee of the European Banking Supervisors (2006). Quantitative Impact Study 5: Overview on Results of the EU countries. Technical report, CEBS.
- [118] Committee on the Global Financial System (2001, April). A survey of stress tests and current practice at major financial institutions. Technical report, Bank for International Settlements.
- [119] Committee on the Global Financial System (2005, January). The role of ratings in structured finance: issues and implications. Technical report, Bank for International Settlements, Basel.
- [120] Cosset, J.C. and Roy, J. (1991). The determinants of country risk ratings. *Journal of International Business Studies*, **22**(1), 135–142.
- [121] Credit Suisse Financial Products (1997). Creditrisk<sup>+</sup> – a credit risk management framework. Technical report, Credit Suisse Financial Products.
- [122] Crook, J.N. (1999). Who is discouraged from applying for credit? *Economics Letters*, **65**, 165–172.
- [123] Crosbie, P. and Bohn, J. (2003). Modeling default risk. Modelling methodology, Moody's KMV.
- [124] Crouhy, M., Galai, D., and Mark, R. (2000). A comparison of current credit risk models. *Journal of Banking & Finance*, **25**, 59–177.

## 492 References

- [125] Crouhy, M., Turnbull, S., and Wakeman, L.M. (1999, Fall). Measuring risk-adjusted performance measurement. *Journal of Risk*, **2**(1), 5–35.
- [126] Cruz, M.G. (2002). *Modelling, measuring and hedging operational risk*, John Wiley & Sons, Chichester, UK.
- [127] Daniell, A. (2000). The myth of cross-selling. *American Banker*, **165**(53), 7–12.
- [128] Davies, G. (2002). *A history of money from ancient times to the present day* (3rd edn). University of Wales Press, Cardiff.
- [129] Dawes, R. and Corrigan, B. (1974). Linear models in decision making. *Psychological Bulletin*, **81**, 1017–1026.
- [130] De Nicolo, G. and Kwast, M.L. (2001). Systemic risk and financial consolidation: Are they related? Federal Reserve discussion paper. *FEDS*, 33.
- [131] de Servigny, A., Peretyatkin, V., Perraudin, W., and Renault, O. (2003). Portfolio risk tracker: Description of the methodology. Technical report, Standard & Poor's Risk Solutions.
- [132] de Servigny, A. and Renault, O. (2003, July). Correlations evidence. *Risk*, **16**(7), 90–94.
- [133] de Servigny, A. and Renault, O. (2004). *Measuring and managing credit risk*. McGraw-Hill, NY.
- [134] Deacon, J. (2003). *Global securitization and CDOs*. Wiley, New York.
- [135] Deakin, E.B. (1972). A discriminant analysis of predictors of business failure. *Journal of Accounting Research*, **10**(1), 167–170.
- [136] Delianedis, G. and Geske, R. (1998). Credit risk and risk neutral default probabilities: Information about ratings migrations and defaults. Technical report, Anderson School, UCLA, Los Angeles.
- [137] Demirguc-Kunt, A. and Detragiache, E. (2000). Monitoring banking sector fragility: A multivariate logit approach. *The World Bank Economic Review*, **14**(2), 287–307.
- [138] Demirguc-Kunt, A. and Detragiache, E. (2002). Does deposit insurance increase banking system stability: an empirical investigation. *Journal of Monetary Economics*, **49**, 1373–1406.
- [139] Dermine, J. and Bissada, Y.F. (2002). *Asset & liability management*, Prentice Hall, New Jersey.
- [140] Desai, V.S., Conway, D.G., Crook, J.N., and Overstreet Jr., G.A. (1997). Credit-scoring models in the credit-union environment using

- neural networks and genetic algorithms. *IMA Journal of Mathematics Applied in Business and Industry*, **8**, 323–346.
- [141] Desai, V.S., Crook, J.N., and Overstreet Jr., G.A. (1996). A comparison of neural networks and linear scoring models in the credit union environment. *European Journal of Operational Research*, **95**(1), 24–37.
- [142] Dewatripont, M. and Tirole, J. (1994). A theory of debt and equity: diversity of securities and manager-shareholder congruence. *Quarterly Journal of Economics*, **109**, 1027–1054.
- [143] Dewyspelaere, T., Garcia, J., and Renault, O. (2004). A comparative analysis of CDO risk analysis models. In *Structured credit products: pricing, rating, risk management and Basel II* (ed. W. Perraudin), Risk Books, London, pp. 245–260.
- [144] Diamond, D. (1984). Financial intermediation and delegated monitoring. *Review of Economic Studies*, **51**, 393–414.
- [145] Diamond, D.W. and Dybvig, P.H. (1983). Bank runs, deposit insurance and liquidity. *Journal of Political Economy*, **91**, 401–419.
- [146] Dichev, I. and Piotroski, J. (2001). The long-run stock returns following bond rating changes. *Journal of Finance*, **56**, 173–203.
- [147] Diebold, F. and Rudebusch, G. (1989). Scoring the leading indicators. *Journal of Business*, **62**(3), 369–391.
- [148] Diebold, F.X. and Santomero, A.M. (1999). Financial risk management in a volatile global environment. *Asia risk*, 35–39.
- [149] Dimakos, X.K. and Aas, K. (2002). Integrated risk modeling. Working paper, The Norwegian Computing Center.
- [150] Dimitras, A., Zanakis, S., and Zopudinis, C. (1996). A survey of business failures with an emphasis on failure prediction methods and industrial applications. *European Journal of Operational Research*, **90**(3), 487–513.
- [151] Donaldson, T.H. (1989). *Credit risk and exposure in securitization and transactions*. St. Martin's Press, New York, NJ.
- [152] Dorfmann, M. (1997). *Introduction to risk management and insurance* (6th edn). Prentice Hall, New Jersey.
- [153] Drew, J., Mani, D.R., Betz, A., and Datta, P. (2001). Targeting customers with statistical and data mining techniques. *Journal of Service Research*, **3**(3).
- [154] Duda, R.O., Hart, P.E., and Stork, D.G. (2001). *Pattern classification* (2nd edn). John Wiley & Sons, Hoboken, New Jersey.

- [155] Duffie, D. and Singleton, K. (1999). Modeling the term structure of defaultable bonds. *Review of Financial Studies*, **12**, 687–720.
- [156] Durand, D. (1941). Risk elements in consumer installment financing. *Studies in Consumer Installment Financing* 8, National Bureau of Economic Research.
- [157] Eales, R. and Bosworth, E. (1998, May). Severity of loss in the event of default in small business and large consumer loans. *Journal of Lending & Credit Risk Management*, **80**(9), 58–65.
- [158] Eberhart, A.C. and Weiss, L.A. (1998). The importance of deviations from the absolute priority rule in Chapter 11 bankruptcy proceedings. *Financial Management*, **27**(4), 106–110.
- [159] Edmister, R.O. (1972). An empirical test of financial ratio analysis for small business failure prediction. *Journal of Financial and Quantitative Analysis*, 1477–1493.
- [160] Efron, B. (1975). The efficiency of logistic regression compared to normal discriminant analysis. *Journal of the American Statistical Association*, **70**, 892–898.
- [161] Eichengreen, B. (2003). Three generations of crises, three generations of crises models. *Journal of International Money and Finance*, **22**, 1089–1094.
- [162] Ellis, D. (1998). Different sides of the same story: Investors' and issuers' views of rating agencies. *The Journal of Fixed Income*, 35–45.
- [163] Elton, E.J., Gruber, M.J., Agrawal, D., and Mann, C. (2001). Explaining the rate spread on corporate bonds. *The Journal of Finance*, **56**(1), 247–277.
- [164] Embrechts, P., Klüppelberg, C., and Mikosch, T. (1997). *Modelling extremal events for insurance and finance*. Springer Verlag, New York.
- [165] Embrechts, P., McNeil, A.J., and Straumann, D. (1999, May). Correlation: Pitfalls and alternatives. *Risk*, **12**, 69–71.
- [166] Engelmann, B. and Rauhmeier, R. (ed.) (2006). *The Basel II risk parameters*. Springer, Berlin.
- [167] Erb, C.B., Harvey, C.R., and Viskanta, T.E. (1996, Spring). Expected returns and volatility in 135 countries. *Journal of Portfolio Management*, 46–58.
- [168] Estrella, A. (2001). Mixing and matching: Prospective financial sector mergers and market valuation. *Journal of Banking and Finance*, **25**(12), 2367–2392.

- [169] Estrella, A. (2000, August). Credit ratings and complementary sources of credit quality information. Technical Report Working Paper 3, Basel Committee on Banking Supervision, BIS, Basel, Switzerland.
- [170] Estrella, A., Peristiani, S., and Park, S. (2002). Capital Ratios and Credit Ratings as Predictors of Bank Failures. In *Credit ratings, methodologies, rationale, and default risk* (ed. M. Ong), Risk Books, London, UK, pp. 233–256.
- [171] European Commission (2005). How to deal with the new rating culture. A practical guide to loan financing for small and medium-sized enterprises. Technical report, EC Directorate-General for Enterprise and Industry.
- [172] European Covered Bond Council (2006, August). *European covered bond fact book* (1st edn). ECBC.
- [173] Fabozzi, F.J. (1993). *Fixed income mathematics*. Probus Publishing Company, Chicago, Illinois.
- [174] Fabozzi, F.J. (ed.) (2001). *Foundations of financial markets and institutions* (3rd edn). Prentice Hall.
- [175] Fabozzi, F.J., Feldstein, S.G., Pollack, I.M., and Zarb, F.G. (ed.) (1983). *The municipal bond handbook*. Dow Jones-Irwin, Homewood, Illinois.
- [176] Fama, E. (1985). ‘What is different about banks?’. *Journal of Monetary Economics*, **15**, 29–40.
- [177] Fama, E. and French, K. (1993). Common risk factors in the returns on stocks and bonds. *Journal of Financial Economics*, **33**, 3–57.
- [178] Fan, J. and Yao, Q. (2003). *Nonlinear time series: non-parametric and parametric methods*. Springer-Verlag, NY.
- [179] Fawcett, T. and Provost, F. (1997). Adaptive fraud detection. *Data Mining and Knowledge Discovery*, **1–3**, 291–316.
- [180] Federal Financial Institutions Examination Council (1979). Uniform Financial Institutions Rating System. Examining Circular 159, USA.
- [181] Federal Reserve Board, FDIC, OCC, and OTS (2003). Banking agencies announce revised plan for implementation of the Basel II framework. Press Release Sept. 30.
- [182] Federal Reserve Board, FDIC, OCC, and OTS (2005). Banking agencies to perform additional analysis before issuing Notice of Proposed Rulemaking related to Basel II. Press Release April 29.
- [183] Fender, I. and Gibson, M. (2001, May). The BIS census on stress tests. *Risk*, **14**(5), 50–52.



- [184] Fender, I., Gibson, M.S., and Mosser, P.C. (2001, November). An international survey of stress tests. *Federal Reserve Bank of New York: Current Issues in Economics and Finance*, 7(10).
- [185] Ferri, G., Liu, L.-G., and Stiglitz, J.E. (1999). The procyclical role of rating agencies: evidence from the east Asian crisis. *Economic Notes*, 28(3), 335–355.
- [186] Figlewski, S. and White, L.J. Orange County: Don't blame derivatives. *SternBusiness*, 1, 30–35.
- [187] Finlay, S.M. (2007). Towards profitability: A utility approach to the credit scoring problem. *Journal of the Operational Research Society*.
- [188] Fisher, R.A. (1936). The use of multiple measurements in taxonomic problems. *Annals of Eugenics*, 7, 179–188.
- [189] Fitzpatrick, P.J. (1932). A comparison of ratios of successful industrial enterprises with those of failed firms. *Certified Public Accountant*, 12, 598–605.
- [190] Flannery, M.J. (2000). Modernizing financial regulation: The relation between interbank transactions and supervisory reform. *Journal of Financial Services Research*, 17(1), 101–116.
- [191] Fogarty, T.C., Ireson, N.S., and Battles, S.A. (1992). Developing rule based systems for credit card applications from data with genetic algorithms. *IMA Journal of Mathematics Applied In Business and Industry*, 4, 53–59.
- [192] Fons, J.S. (1991). An approach to forecasting default rates. Special report, Moody's.
- [193] Franks, J., de Servigny, A., and Davydenko, S. (2004). Comparative analysis of the recovery process and recovery rates for private companies in the UK, France, and Germany. Technical report, Standard & Poor's.
- [194] Freixas, X. and Rochet, J.-C. (1997). *Microeconomics of banking*. MIT Press, Cambridge, MA.
- [195] Frey, R. and McNeil, A.J. (2002). VaR and expected shortfall in portfolios of dependent credit risks: Conceptual and practical insights. *Journal of Banking and Finance*, 26(7), 1317–1334.
- [196] Frey, R. and McNeil, A.J. (2003). Modeling dependent defaults. *Journal of Risk*, 6(1), 59–92.
- [197] Fridson, M. and Jonsson, J.G. (1997, Winter). Contingent claim analysis. *The Journal of Portfolio Management*, 31–43.
- [198] Friedman, C. and Sandow, S. (2003, November). Ultimate recoveries. *Risk*.

- [199] Frindson, M.S. (1999, November/December). Why do bond rating agencies exist? *Extra credit (Merrill lynch)*.
- [200] Frost, C.A. (2006). Credit rating agencies in capital markets: A review of research evidence on selected criticisms of the agencies. *Journal of Accounting, Auditing and Finance*. forthcoming.
- [201] Frye, J. (2000, April). Collateral damage. *Risk*, 91–94.
- [202] Frye, J. (2000, November). Depressing recoveries. *Risk*, 108–111.
- [203] Fuertes, A. and Kalotychou, E. (2005). On sovereign credit migration: Small-sample properties and rating evolution. Technical report, City University London.
- [204] Gale, D. and Hellwig, M. (1985). Incentive comparative debt contracts: The one-period problem. *Review of Economic Studies*, **52**, 647–663.
- [205] Gentry, J.A., Newbold, P., and Whitford, D.T. (1985). Classifying bankrupt firms with fund flow components. *Journal of Accounting Research*, **23**(1), 146–160.
- [206] Gertner, R.H., Scharfstein D.S. and Stein J.C. (1994). Internal versus external capital markets. *Quarterly Journal of Economics*, **109**(4), 1211–1230.
- [207] Ghosh, A. (2003). Solution framework for credit risk under Basel II. White paper, Wipro technologies.
- [208] Gilbert, R.A., Meyer, A.P., and Vaughan, M.D. (1999). The role of supervisory screens and econometric models in off-site surveillance. *Review, Federal Reserve Bank of St. Louis*, **81**, 31–56.
- [209] Glantz, M. (2003). *Managing bank risk*, Academic Press, London, UK.
- [210] Gollinger, T.L. and Morgan, J.B. (1993, Winter). Calculation of an efficient frontier for a commercial loan portfolio. *Journal of Portfolio Management*, 39–46.
- [211] Gombola, M., Haskins, M., Ketz, J., and Williams, D. (1987). Cash flow in bankruptcy prediction. *Financial Management*, 55–65.
- [212] Gordy, M.B. (2001). A comparative anatomy of credit risk models. *Journal of Banking and Finance*, **24**, 119–149.
- [213] Gordy, M.B. (2003). A risk-factor model foundation for ratings-based bank capital rules. *Journal of Financial Intermediation*, **12**, 199–232.
- [214] Gordy, M.B. and Howells, B. (2006). Procyclicality in Basel II: Can we treat the disease without killing the patient? *Journal of Financial Intermediation*, **15**(3), 395–417.

- [215] Gouriéroux, C., Laurent, J.-P., and Scaillet, O. (2000). Sensitivity analysis of values at risk. *Journal of Empirical Finance*, **7**, 225–245.
- [216] Green, E. (1989). *Banking: an illustrated history*. Phaidon Inc. Ltd, London, UK.
- [217] Green, S. (2004). *Manager's guide to the Sarbanes-Oxley act: improving internal controls to prevent fraud*. Wiley, Hoboken, New Jersey.
- [218] Grier, W.A. (2001). *Credit analysis of financial institutions*. Euromoney Books, London.
- [219] Grönroos, C. (1997). From marketing mix to relationship marketing – towards a paradigm shift in marketing. *Management Decision*, **35**(4), 322–339.
- [220] Grunert, J., Norden, L., and Weber, M. (2005). The role of non-financial factors in internal credit ratings. *Journal of Banking & Finance*, **29**(2), 509–531.
- [221] Grunert, J. and Weber, M. (2005). Recovery rates of bank loans: Empirical evidence for Germany. Technical report.
- [222] Guill, G.D. and Smithson, C. (ed.) (2005, November). *Sound practices in credit portfolio management*. International Association of Credit Portfolio Managers.
- [223] Gundlach, M. and Lehrbass, F. (ed.) (2004). *Creditrisk<sup>+</sup> in the banking industry*. Springer Finance. Springer-Verlag, Berlin.
- [224] Gup, B.E. (2004). *The new Basel capital accord*. South-Western Educational Publishing, USA.
- [225] Gupton, G.M., Finger, C.C., and Bhatia, M. (1997). Creditmetrics. Technical document, Morgan Guaranty Trust Co.
- [226] Gupton, G. and Stein, R. (2002). LossCalc<sup>TM</sup>: Model for predicting Loss Given Default (LGD). Rating methodology, Moody's.
- [227] Gupton, G. and Stein, R. (2005). LossCalc V2: Dynamic prediction of LGD. Rating methodology, Moody's.
- [228] Gürtler, M. and Heithecker, D. (2005). Sicherheitenoptimierung: adäquate Anrechnung von Bürgschaften. *Kreditwesen*, **17**, 926–930.
- [229] Hajivassiliou, V. (1987). The external debt repayment problems of LDCs: an econometric model based on panel data. *Journal of Econometrics*, **36**, 205–230.

- [230] Hallberg, G. (1995). *All customers are not created equal: the differential marketing strategy for brand loyalty and profits*. John Wiley, New York, USA.
- [231] Hamilton, D.T. (2005, July). Moody's senior ratings algorithm and estimated senior ratings. Default risk service database documentation, Moody's Investors Service.
- [232] Hamilton, D.T. and Cantor, R. (2005, December). Rating transitions and defaults conditional on rating outlooks revisited: 1995–2005. Special comment, Moody's Investors Service.
- [233] Hamilton, D.T., Varma, P., Ou, S., and Cantor, R. (2006). Default and recovery rates of corporate bond issuers, 1920–2005. Technical report, Moody's Investors Service.
- [234] Hamilton, D.T. and Varma, P. (2005, January). Default rates of corporate bond issuers, 1920–2004. Technical report, Moody's Global Credit Research.
- [235] Hamilton, J. (1994). *Time series analysis*. Princeton University Press, Princeton, New Jersey.
- [236] Hampel, F.R., Ronchetti, E.M., Rousseeuw, P.J., and Stahel, W.A. (1986). *Robust statistics, the approach based on influence functions*. Wiley, Hoboken, New Jersey.
- [237] Hanazaki, M. and Horiuchi, A. (2003). A review of Japan's bank crisis from the governance perspective. *Pacific-Basin Finance Journal*, **11**, 305–325.
- [238] Hand, D.J. (2001). Modelling consumer credit risk. *IMA Journal of Management Mathematics*, **12**(139–155).
- [239] Hand, D.J. and Henley, W.E. (1997). Statistical classification methods in consumer risk. *Journal of the Royal Statistical Society, Series A*, **160**, 523–541.
- [240] Hand, D.J., McConway, K.J., and Stanghellini, E. (1997). Graphical models of applicants for credit. *IMA Journal of Mathematics Applied In Business and Industry*, **8**, 143–155.
- [241] Hand, J., Holthausen, R., and Leftwich, R. (1992). The effect of bond rating agency announcements on bond and stock prices. *Journal of Finance*, **47**, 733–752.
- [242] Hansen, M., Olson, K., Hovhannisyanyan, N., Jennings, S., Brewer, A., Dyke, H., Kohansky, G., Neugebauer, M., and Ramadurai, K. (2005). Basel II: Bottom-Line Impact on Securitization Markets. Special report, Fitch Ratings.

- [243] Haque, N.U., Kumar, M.S., Mark, N., and Mathieson, D.J. (1996). The economic content of indicators of developing country creditworthiness. *IMF Staff Papers*, **43**, 688–724.
- [244] Haque, N.U., Mark, N., and Mathieson, D.J. (1998). The relative importance of political and economic variables in creditworthiness ratings. Working Paper 46, IMF.
- [245] Hastie, T., Tibshirani, R., and Friedman, J. (2001). *The elements of statistical learning. Data mining, inference and prediction*. Springer Series in Statistics. Springer Verlag, New York.
- [246] Hefferman, S. (2005). *Modern banking*. John Wiley & Sons, Hoboken, New Jersey.
- [247] Heitfeld, E. and Barger, N. (2003). Treatment of Double-Default and Double-Recovery Effects for Hedged Exposures under Pillar I of the Proposed New Basel Capital Accord. White paper, Staff of the Board of Governors of the Federal Reserve System.
- [248] Heitfield, E.A. (2004). Rating system dynamics and bank-reported default probabilities under the new Basel capital accord. Technical report.
- [249] Henley, W.E. (1995). *Statistical aspects of credit scoring*. Ph. D. thesis, The Open University, Milton Keynes, UK.
- [250] Henley, W.E. and Hand, D.J. (1996). A k-nearest neighbor classifier for assessing consumer credit risk. *Statistician*, **44**, 77–95.
- [251] Henrard, L. and Olieslagers, R. (2004, March). Risk management of a financial conglomerate. Newsletter of the Risk Management Section 1, Society of Actuaries, Schaumburg, IL.
- [252] Herfindahl, O.C. (1959). *Copper costs and prices: 1870–1957*. The Johns Hopkins Press, Baltimore.
- [253] Herfindahl, O.C. (1982, May). The Herfindahl index: Another measure of concentration. *Business Week*.
- [254] Herring, R.J. and Santomero, A.M. (1990, December). The corporate structure of financial conglomerates. *Journal of Financial Services Research*, 471–497.
- [255] Hirschman, A.O. (1964). The paternity of an index. *American Economic Review*, **54**, 761–762.
- [256] Hirschman, A.O. (1980). *National power and the structure of foreign trade*. University of California Press, Los Angeles.
- [257] Hoenig, A. (1997). The search for optimal regulation: the pre-commitment approach. *Federal Reserve of Philadelphia Bulletin*.

- [258] Hoggarth, G. and Saporta, V. (2001). Costs of banking crises, some empirical evidence. *Financial Stability Review, Bank of England*, 148–161.
- [259] Holt, M.F. (2005). *Sarbanes-Oxley act*. CIMA Publishing, London.
- [260] Holton, G. (2003). *Value-at-risk: theory and practice*, Elsevier Science, San Deigo, USA.
- [261] Horrigan, J. (1966). The determination of long-term credit standing with financial ratios. *Journal of Accounting Research (Supplement)*, **4**, 44–62.
- [262] Hoti, S. and McAleer, M. (2003). An empirical assessment of country risk ratings and association models. *Journal of Economic Surveys*, **18**(4), 539–588.
- [263] Hu, J. and Cantor, R. (2003, June). Structured finance rating transitions. *Journal of Fixed Income*, **13**(1), 7–27.
- [264] Hu, J. and Cantor, R. (2004, March). Defaults and Loss Given Default of structured finance securities. *Journal of Fixed Income*.
- [265] Huber, P.J. (1981). *Robust statistics*. John Wiley & Sons, Inc., Hoboken, New Jersey.
- [266] Hubert, M., Rousseeuw, P.J., and Vanden Branden, K. (2005) ROBPCA: a new approach to robust principal component analysis. *Technometrics*, **47**, 64–79.
- [267] Hughes, J.P. and Mester, L.J. (1998). Bank capitalization and cost: Evidence of scale economies in risk management and signalling. *Review of Economics and Statistics*, **80**(2), 314–325.
- [268] Hull, J.C. (2000). *Options, futures and other derivatives* (4th edn). Prentice Hall, New Jersey.
- [269] Hull, J. and White, A. (2000). Valuing credit default swaps: No counterparty risk. *Journal of Derivatives*, **8**, 29–40.
- [270] Hull, J., Predescu-Vasvari, M. and White, A. (2002). The relationship between credit default swap spreads, bond yields, and credit rating announcements. Technical report, Joseph L. Rotman School of Management.
- [271] Hunter, R. and Linnell, I. (2005). Country-specific treatment of recovery ratings. Credit policy, Fitch Ratings.
- [272] Hutchinson, J.M., Lo, A.W., and Poggio, T. (1994). A nonparametric approach to pricing and hedging derivative securities via learning networks. *Journal of Finance*, **49**, 851–889.

- [273] Huysmans, J., Baesens, B., Van Gestel, T., and Vanthienen, J. (2006). Using self-organizing maps for credit scoring. *Expert Systems with Applications*, **30**(3), 479–487.
- [274] Ineke, J., Friesser, O., Miyagishima, C., Barton, S., and Bradley, M. (2004). *Basel II A–Z*. Fixed Income Research. Morgan Stanley.
- [275] Ineke, J., Friesser, O., Miyagishima, C., Barton, S., and Bradley, M. (2004). *Basel II A–Z*. Morgan Stanley.
- [276] International Accounting Standard Board (IASB). International Financial Reporting Standard (IFRS). Technical report, IASCF Publications Department.
- [277] International Monetary Fund. Japan: Financial System Stability Assessment and Supplementary Information, IMF, Country Report (2003). Technical report.
- [278] International Organization of Securities Commissions (2004). Code of conduct fundamental for credit rating agencies. Technical report.
- [279] Israel, R.B., Rosenthal, J.S., and Wei, J.Z. (2001). Finding generators for Markov chains via empirical transition matrices. *Mathematical Finance*, **11**, 245–265.
- [280] Izan, H.Y. (1984). Corporate distress in Australia. *Journal of Banking and Finance*, **8**, 303–320.
- [281] Jankowitsch, R., Pichler, S., and Schwaiger, W.S.A. (2007). Modelling the economic value of credit rating systems. *Journal of Banking and Finance*, **31**(1), 181–198.
- [282] Jarrow, R.A. and Protter, P. (2004). Structural versus reduced form models: a new information based perspective. *Journal of Investment Management*, **2**(2), 1–10.
- [283] Jarrow, R. and Turnbull, S. (1995). Pricing derivatives on financial securities subject to default risk. *Journal of Finance*, **50**, 53–86.
- [284] Jarrow, R.A., van Deventer, D., and Wang, X. (2003). A robust test of Merton’s model for credit risk. *Journal of Risk*, **6**(1), 39–58.
- [285] Jewell, J. and Livingston, M. (1998). Split ratings, bond yields, and underwriter spreads for industrial bonds. *Journal of Financial Research*, **21**, 185–204.
- [286] Jewell, J. and Livingston, M. (1999, August). A comparison on bond ratings from Moody’s, S&P and Fitch. *Financial Markets, Institutions & Instruments*, **8**(4).

- [287] Jones, D. (2000). Emerging problems with the Basel Capital Accord: Regulatory arbitrage and related issues. *Journal of Banking and Finance*, **24**(1–2), 35–58.
- [288] Jonsson, J.G. and Fridson, M.S. (1996, June). Forecasting default rates on high yield bonds. *The Journal of Fixed Income*, 69–77.
- [289] Jorion, P. (1995). *Big bets gone bad: derivatives and bankruptcy in Orange County*. Academic Press, San Diego.
- [290] Jorion, P. (2000). Risk management lessons from long-term capital management. *European Financial Management*, **6**, 277–300.
- [291] Jorion, P. (2003). *Financial risk manager handbook* (2nd edn). Finance. Wiley, Hoboken, New Jersey.
- [292] Kamakura, W.A., Ramaswami, S.N., and Srivastava, R.K. (1991). Applying latent trait analysis in the evaluation of prospects for cross-selling of financial services. *International Journal of Research in Marketing*, **8**, 329–349.
- [293] Kaminsky, G.L. (1999). Currency and banking crises: The early warnings of distress. Working Paper 99/179, IMF.
- [294] Kaminsky, G. and Reinhart, C. (1999). The twin crises: the causes of banking and balance payment problems. *American Economic Review*, **89**(3), 473–500.
- [295] Kaminsky, G.L. and Reinhart, C.M. (2000). On crises, contagion, and confusion. *Journal of International Economics*, **51**, 145–168.
- [296] Kaminsky, G. and Schmukler, S. (2002). Emerging market instability: Do sovereign ratings affect country risk and stock returns? *World Bank Economic Review*, **16**(2), 171–195.
- [297] Kane, E.J. (1987). Competitive Financial Reregulation: An International Perspective. In *Threats to international financial stability* (ed. R. Portes and A. Swoboda), Cambridge University Press, London.
- [298] Kaplan, R.S. and Anderson, S.R. (2007). *Time-driven activity-based costing*. Harvard Business School Press.
- [299] Karatzas, I. and Shreve, S.E. (1991). *Brownian motion and stochastic calculus* (2nd edn). Springer New York, USA.
- [300] Karatzas, I. and Shreve, S.E. (1998). *Methods of mathematical finance*. Springer New York, USA.
- [301] Katz, L. and Chew, W.H. (2007). Recovery analytics update: expanding recovery ratings and enhancing issue ratings. Commentary report, Standard & Poor's.



- [302] Kaufman, G. (1994, April). Bank contagion: a review of the theory and evidence. *Journal of Financial Services Research*, 123–150.
- [303] Keasey, K., McGuinness, P., and Short, H. (1990). Multilogit approach to predicting corporate failure – further analysis and the issue of signal consistency. *Omega*, **18**(1), 85–94.
- [304] Keenan, S.C. and Sobehart, J.R. (2002). *The meaning of agency ratings: a behavioral model of rating assignment*. Risk Books UK, pp. 103–124.
- [305] Keenan, S.C., Sobehart, J., and Hamilton, D.T. (1999, August). Predicting default rates: a forecasting model for Moody's issuer-based default rates. Global credit research, Moody's Investors Service.
- [306] Kelly, M.G. and Hand, D.J. (1999). Credit scoring with uncertain class definitions. *IMA Journal of Mathematics Applied in Business and Industry*, **10**, 331–345.
- [307] King, J.L. (2001). *Operational risk: measurement and modelling*. Wiley, New York.
- [308] Klinger, D. and Sarig, O. (2000). The information value of bond ratings. *Journal of Finance*, **55**, 2879–2902.
- [309] Klopfer, M. (2005). *Gestion financière des collectivités locales* (4th edn). Guides et méthodes. Le Moniteur.
- [310] Kocagil, A.E., Reyngold, A., Stein, R.M., and Ibarra, E. (2002). Moody's RiskCalc™ Model for Privately-Held US Banks. Global credit research, Moody's Investors Service.
- [311] Koch, T.W. and Macdonald, S.S. (2005). *Bank management* (6th edn). South-Western Pub., USA.
- [312] Kou, J. and Varotto, S. (2004). Predicting agency rating movements with spread implied ratings. Technical report, ISMA Centre, The University of Reading, UK.
- [313] Koyluoglu, H.U. and Hickman, A. (1998, October). Reconcilable differences. *Risk*, 56–62.
- [314] Krayenbuehl, T.E. (1985). *Country risk: assessment and monitoring*. Lexington Books, Toronto.
- [315] Kun, C.L., Ingoo, H., and Youngsig, K. (1996). Hybrid neural network models for bankruptcy predictions. *Decision Support Systems*, **18**, 63–72.
- [316] Kuritzkes, A. (2002). Operational risk capital: A problem of definition. *Journal of Risk Finance*, **4**(1), 47–56.
- [317] Kuritzkes, A., Schuermann, T., and Weiner, S.M. (2002). Risk measurement, risk management and capital adequacy in financial

- conglomerates. Brookings-Wharton Papers on Financial Services 03-02, Wharton Financial Institutions Center.
- [318] Kutty, G. (1990). Logistic regression and probability of default of developing countries debt. *Applied Economics*, **21**, 1649–1660.
- [319] La Porta, R., Lopez-De-Silanes, F., Shleifer, F., and Vishny, R. (2002). Investor protection and corporate valuation. *Journal of Finance*, **57**(3), 1147–1170.
- [320] Lacher, R.C., Coats, P.K., Sharma, S.C., and Fant, L.F. (1995). A neural network for classifying the financial health of a firm. *European Journal of Operational Research*, **85**, 53–65.
- [321] Lambertson, D. and Lapeyre, B. (1996). *Introduction to stochastic calculus applied to finance*. Chapman & Hall.
- [322] Lambin, J.J. (1989). *Le marketing stratégique*. McGraw-Hill, Paris.
- [323] Laster, D. (2003, August). Insurance company ratings. Sigma 4, Swiss Re.
- [324] Lau, A.H.L. (1987). A five-state financial distress prediction model. *Journal of Accounting Research*, **25**(1), 127–138.
- [325] Le Bras, A. and Andrews, D. (2003). Bank rating methodology. Criteria report, Fitch Ratings.
- [326] Lederman, J. (1990). *The handbook of asset-backed securities*. Prentice Hall, New York.
- [327] Leshno, M. and Spector, Y. (1996). Neural network prediction analysis: the bankruptcy case. *Neurocomputing*, **10**, 125–147.
- [328] Levey, D.H. (2003). *Moody's credit statistical handbook, country credit*. Moody's Investor Service, New York.
- [329] Lewellen, W.G. (1971). A pure financial rationale for the conglomerate merger. *Journal of Finance*, **26**(2), 521–537.
- [330] Lewis, E.M. (1992). *An introduction to credit scoring*. Athena Press, San Rafael, CA.
- [331] Lewis, M. and Algaoud, L.M. (2001). *Islamic banking*. Edward Elgar, Northampton, MA.
- [332] Li, H.G. and Hand, D.J. (1997). Direct versus indirect credit scoring classifications. *Journal of the Operational Research Society*, **53**(6), 637–647.
- [333] Libby, R. (1975). Accounting ratios and the prediction of failure: some behavioral evidence. *Journal of Accounting Research*, **13**(1), 150–161.

- [334] Lintner, J. (1965). The valuation of risk assets and the selection of risky investments in stock portfolios and capital budgets. *Review of Economics and Statistics*, **47**(1), 13–37.
- [335] Little, R.J.A. (1992). Regression with missing x's: a review. *Journal of the American Statistical Association*, **87**(420), 1227–1230.
- [336] Liu, B., Kocagil, A.E., and Gupton, G.M. (2007). Fitch CDS Implied Ratings. Quantitative financial research special report, Fitch Ratings.
- [337] Lo, A.W. (1986). Logit versus discriminant analysis: a specification test with application to corporate bankruptcies. *Journal of Econometrics*, **31**, 151–178.
- [338] Longhofer, D.S and Carlstrom, C.T. (1995). Absolute priority rule violations in bankruptcy. *Economic Review*, **31**(4), 21–30.
- [339] Lown, C.S., Osler, C.L., Strahan, P.E., and Sufi, A. (2000, October). The changing landscape of the financial services industry: What lies ahead? *Federal Reserve Bank of New York, Economic Policy Review*, 39–55.
- [340] Lu, C., Van Gestel, T., Suykens, J.A.K., Van Huffel, S., Vergote, I., and Timmerman, D. (2003). Classification of ovarian tumor using Bayesian Least Squares Support Vector Machines. *Artificial Intelligence in Medicine*, **28**, 281–306.
- [341] Maddala, G.S. and Kim, I.M. (1998). *Cointegration, unit roots and structural change*. Cambridge University Press, Cambridge.
- [342] Madura, J. (2001). *Financial markets and institutions*. South-Western College Publishing, USA.
- [343] Markowitz, H. (1952). Portfolio selection. *Journal of Finance*, **7**(1), 77–91.
- [344] Maronna, R.A., Martin, D., Yohai, V., and Martin, D.R. (2006). *Robust statistics: theory and methods*. Wiley, Hoboken, New Jersey.
- [345] Marrison, C. (2002). *Fundamentals of risk measurement*. McGraw & Hill, London.
- [346] Martens, D., Baesens, B., Van Gestel, T., and Vanthienen, J. (2006). Comprehensible credit scoring models using rule extraction from Support Vector Machines. *European Journal of Operational Research*, **183**(3), 1466–1476.
- [347] Martinez-Alas, L.E., Levey, D.H., and Truglia, V.J. (2004). A quantitative model for foreign currency government bond ratings. Technical report, Moody's Investors Service, New York.
- [348] Matten, C. (2003). *Managing bank capital. Capital allocation and performance measurement*. Wiley, Hoboken, New Jersey.

- [349] McCullagh, P. and Nelder, J.A. (1989). *Generalized linear models*. Chapman and Hall, London.
- [350] McDonald, A. and Eastwood, G. (2000). Credit risk rating at Australian banks. Technical Report 7, Australian Prudential Regulation Authority.
- [351] McKinley, J. and Barrickman, J. (1994). *Strategic credit risk management*. Robert Morris Associates, Philadelphia.
- [352] McKinsey & Company (1998). CreditPortfolioView™ Approach Documentation and User's Documentation. Technical report, Zurich.
- [353] Meehl, P.E. (1954). *Clinical versus statistical prediction: a theoretical analysis and a review of the evidence*. University of Minnesota Press, Minneapolis.
- [354] Merritt, R. and Hunter, R. (2005). Recovery ratings: exposing the components of credit risk. Credit policy, special report, Fitch Ratings.
- [355] Merton, R.C. (1974). On the pricing of corporate debt: the risk structure of interest rates. *Journal of Finance*, **29**, 449–452.
- [356] Merton, R. (1995). A functional perspective of financial intermediation. *Financial Management*, **24**, 23–41.
- [357] Meyer, P. and Pifer, H.W. (1970). Prediction of bank failures. *Journal of Finance*, **25**(4), 853–867.
- [358] Micha, B. (1984). Analysis of business failures in France. *Journal of Banking and Finance*, **8**, 281–291.
- [359] Mikosch, T. (1998). *Elementary stochastic calculus – with finance in view, Volume 6 of Advanced series on statistical science & applied probability*. World Scientific Publishing, Singapore.
- [360] Mills, P.S. and Presley, J.R. (1999). *Islamic finance: theory and practice*. Palgrave, Hampshire, New York.
- [361] Mitchell, T.M. (1997). *Machine learning*. McGraw-Hill, London.
- [362] Modigliani, F. and Miller, M. (1958). The cost of capital, corporation finance and the theory of investment. *American Economic Review*, **48**, 261–297.
- [363] Molinari, M. and Serrano-Cinca, C. (1999). Bank failure: a multi-dimensional scaling approach. *European Journal of Finance*, **7**(2), 165–183.
- [364] Molyneux, P. and Iqbal, M. (2005). *Banking and financial systems in the Arab world*. Palgrave Macmillan, New York.
- [365] Monsaert, S., Van Gestel, T., and Wauters, K. (2006). Early warning indicators for sovereign crises. *Bank & Financierwezen* (4).

- [366] Moral, G. (2006). EAD Estimates for Facilities with Explicit Limits. In *The Basel II risk parameters* (ed. B. Engelmann and R. Rauhmeier), Springer, Heidelberg/Berlin, pp. 197–242.
- [367] Moral, G. and García-Baena, R. (2002). LGD Estimates in a Mortgage Portfolio. *Estabilidad Financiera, Banco de España*, **3**, 127–164.
- [368] Morgan, R.M. and Hunt, S.D. (1994). The commitment-trust theory of relationship marketing. *Journal of Marketing*, **29**, 319–329.
- [369] Morris, R. (1997). *Early warning indicators of corporate failure*. Ashgate, Brookfield, US.
- [370] Mossin, J. (1966, October). Equilibrium in a capital asset market. *Econometrica*, **34**(4), 768–783.
- [371] Nakada, P., Shah, H., Koyluoglu, H.U., and Colignon, O. (1999). P&C RAROC: A Catalyst for Improved Capital Management in the Property and Casualty Insurance Industry. *Journal of Risk Finance* (Fall), 1–18.
- [372] Nash, E.L. (1994). *Direct marketing: strategy, planning, execution*. (3rd edn). McGraw-Hill, NY.
- [373] Nasir, M.L., John, R.I., and Bennett, S.C. (2000) Predicting corporate bankruptcy using modular neural networks. *Proceedings of the IEEE/IAFE/INFORMS/ Conference on Computational Intelligence for Financial Engineering*, pp. 86–78.
- [374] National Institute of Economic and Social Research (1999). The National Institute Global Econometric Model (NIGEM): The World Model Manual. Technical report, National Institute of Economic and Social Research, London, UK.
- [375] Needham, C. and Verde, M. (2006). Fitch Ratings Global Corporate Finance 1990–2005 Transition and Default Study. Credit market research, Fitch Ratings.
- [376] Nelson, C. and Siegel, A. (1987). Parsimonious modelling of yield curves. *Journal of Business*, **60**, 473–489.
- [377] Nickell, P., Perraudin, W., and Varotto, S. (2000). Stability of rating transitions. *Journal of Banking and Finance*, **24**, 203–227.
- [378] Nisbet, R., Krantz, D., Jepson, C., and Fong, G. (1982). Improving inductive inference. In *Judgment under uncertainty* (ed. D. Kahneman, P. Slovic, and A. Tversky).

- [379] Ohlson, J.A. (1980). Financial ratios and the probabilistic prediction of bankruptcy. *Journal of Accounting Research*, **18**(1), 109–131.
- [380] Øksendal, B. (1998). *Stochastic differential equations: an introduction with applications* (5th edn). Springer Verlag, New York.
- [381] Ong, M.K. (ed.) (2004). *The Basel handbook: a guide for financial practitioners*. Risk Books, London.
- [382] Ong, M.K. (ed.) (2004). *Credit ratings, methodologies, rationale and default risk*. Risk Books, London.
- [383] Ooghe, H., Joos, P., and De Bourdeaudhuij, C. (1995). Financial distress models in Belgium: The results of a decade of empirical research. *The International Journal of Accounting*, **30**, 245–274.
- [384] Ooghe, H. and Verbaere, E. (1985). Predicting business failure on the basis of accounting data: The Belgian experience. *The International Journal of Accounting*, **9**(2), 19–44.
- [385] Oral, M., Kettani, O., Cosset, J.C., and Daouas, M. (1992). An estimation model for country risk ratings. *International Journal of Forecasting*, **8**.
- [386] Packer, F. (1999). Credit Risk in Japan's Corporate Bond Market. *Current Issues in Economics and Finance, Federal Reserve Bank of New York*, **5**(15).
- [387] Packer, F. (2003). Mind the gap: domestic versus foreign currency sovereign ratings. *BIS Quarterly Review*, 55–63.
- [388] Partnoy, F. (1999). The Siskel and Ebrt of Financial Markets: Two Thumbs Down for the Credit Rating Agencies. *Washington University Law Quarterly*, **77**(3), 619–712.
- [389] Patrino, P.F., Buckley, K.M., and Burke, J.A. (2001, January). Fitch's approach to 'group' insurance ratings. Special report, Fitch.
- [390] Pederzoli, C. and Torricelli, C. (2005). Capital requirements and business cycle regimes: Forward-looking modelling of default probabilities. *Journal of Banking and Finance*, **29**(12), 3121–3140.
- [391] Perraudin, W. (ed.) (2004). *Structured credit products: pricing, rating, risk management and Basel II*. Risk Books, London.
- [392] Petersen, M. and Rajan, R. (1994). The benefits of lending relationships: Evidence from small business data. *Journal of Finance*, **49**, 3–37.

## 510 References

- [393] Pilloff, S.J. and Santomero, A.M. (1998). The value effects of bank mergers and acquisitions. In: *Bank mergers & acquisitions* (ed. Y. Amihud and G. Miller), Kluwer Academic, Boston, MA, pp. 59–78.
- [394] Pinchock, P. (2001). The SAP solution for Basel II. White paper, SAP.
- [395] Platt, H.D. and Platt, M.B. (1991). A note on the use of industry-relative ratios in bankruptcy prediction. *Journal of Banking and Finance*, **15**(6), 1183–1194.
- [396] Pluchart, J.J. (2000). *Ingénierie financière de projet*. Editions d'organisation, France.
- [397] Poon, W.P.H. (2003). Are unsolicited credit ratings biased downward? *Journal of Banking & Finance*, **27**, 593–614.
- [398] Poon, W.P.H., Firth, M., and Fung, H. (1999). A multivariate analysis of the determinants of Moody's bank financial strength ratings. *Journal of International Financial Markets*, **9**(3), 267–283.
- [399] Powell, A. (2004). Basel II and Developing Countries: Sailing through the Sea of Standards. World Bank Policy Research Working Paper 3387, The World Bank.
- [400] PriceWaterhouseCoopers. Study on the financial and macroeconomic consequences of the draft proposed new capital requirements for banks and investment firms in the EU. Technical report, PriceWaterhouseCoopers.
- [401] Pykhtin, M. (ed.) (2005). *Counterparty credit risk modelling*. Risk Books, London.
- [402] Rajan, R. (1998). The past and future of commercial banking viewed through an incomplete contract lens. *Journal of Money, Credit and Banking*, **3**, 525–549.
- [403] Rao, B. (1994). *Cointegration for the applied economist*. MacMillan, London.
- [404] Rea, A. (2004, October). Weighting risk, Basel II and the challenge for Mid-Tier banks. Technical report, Economist Intelligence Unit.
- [405] Refenes, A.N., Burgess, A.N., and Bentz, Y. (1997). Neural networks in financial engineering: A study in methodology. *IEEE Transactions on Neural Networks*, **8**, 1222–1267.
- [406] Reicheld, F.F. and Kenny, D.W. (1990). The hidden advantages of customer retention. *Journal of Retail Banking*, **4**, 19–23.
- [407] Reinartz, W.J. and Kumar, V. (2000). On the profitability of long-life customers in a noncontractual setting: an empirical investigation and implications for marketing. *Journal of Marketing*, **64**, 17–35.

- [408] Reyngold, A., Kocagil, A.E., and Gupton, G.M. (2007). Fitch Equity Implied Rating and Probability of Default Model. Quantitative financial research special report, Fitch Ratings.
- [409] Riley, D., Fox, R., Scher, R., Harting, M., and McCormack, J. (2005, December). Sovereign issuer default and recovery ratings. Criteria report, Fitch Ratings.
- [410] Ripley, B.D. (1996). *Pattern recognition and neural networks*. Cambridge University Press, Cambridge.
- [411] Rivoli, P. and Brewer, T.L. (1997). Political instability and country risk. *Global Finance Journal*, **8**, 309–321.
- [412] Rose, P.S. and Conway, S. (2004). *Bank management & financial services*. McGraw-Hill, London.
- [413] Rosenberg, L.J. and Czepiel, J.A. (1984). A marketing approach to customer retention. *Journal of Consumer Marketing*, **1**, 45–51.
- [414] Rosenbluth, G. (1955). Measures of concentration. In *business concentration and price policy*, Princeton. National Bureau of Economic Research, Princeton University Press, Princeton, USA.
- [415] Ross, S., Westerfield, R., and Jordan, B. (2007). *Fundamentals of corporate finance*. McGraw Hill, London.
- [416] Rothbard, M.N. (2002). *A history of money and banking in the United States: the colonial era to World War II*. Ludwig Von Mises Inst.
- [417] Rousseeuw, P.L. and Leroy, A. (1987). *Robust regression and outlier detection*. John Wiley & Sons, Hoboken, New Jersey.
- [418] Rowan, M.J., Stump, P., De Bodard, E., and Staples, D. (2006). Probability-of-default and loss-given-default ratings for non-financial speculative-grade corporate obligors. Technical report, Moody's Investor Service.
- [419] Roy C. Smith, R.C. and Walter, I. (2003). *Global banking* (2nd edn). Oxford University Press, USA.
- [420] Rust, R.T. and Zahorik, A.J. (1993). Customer satisfaction, customer retention, and market share. *Journal of Retailing*, **69**(2), 193–215.
- [421] Sandage, S.A. (2005). *Born losers: a history of failure in America*. Harvard University Press, Cambridge, MA, and London, England.
- [422] Sardi, A. (2004). *Bâle II*. Afges.
- [423] Sarkar, S. and Sriram, R. (2001). Bayesian models for early warnings of bank failures. *Management Science*, **47**(10), 1457–1475.
- [424] Saunders, A. (1999). *Credit risk measurement*. Wiley, Chichester.
- [425] Saunders, A. and Allen, L. (2002). *Credit risk measurement*. Wiley, NY.



## 512 References

- [426] Saunders, A. and Cornett, M.M. (2003). *Financial institutions management: a risk management approach* (4th edn). McGraw Hill, New York.
- [427] Saunders, A. and Walter, I. (1994). *Universal banking in the US?* Oxford University Press, Oxford, UK.
- [428] Sawyer, J. (1966). Measurement and prediction: clinical and statistical. *Psychological Bulletin*, 178–200.
- [429] Schaeffer, H.A. (2000). *Credit risk management: a guide to sound business decisions*. Wiley, New York.
- [430] Schölkopf, B., Tsuda, K., and Vert, J.-P. (ed.) (2004). *Kernel methods in computational biology*. MIT Press, Cambridge, MA.
- [431] Schönbucher, P. (2003). *Credit derivatives pricing models: models, pricing and implementation*. Wiley, Chichester.
- [432] Schuermann, T. (2004). Why were banks better off in the 2001 recession? *Current Issues in Economics and Finance, Federal Reserve Bank of New York*, **10**(1).
- [433] Scott, J. (1981). The probability of bankruptcy: A comparison of empirical predictions and theoretical models. *Journal of Banking and Finance*, **5**(3), 317–344.
- [434] Scott, K. (1977). The Dual Banking System: A Model of Competition in Regulation. *Stanford Law Review*, **77**(3), 619–712.
- [435] Seemann, J., Dahlkamp, A., and Heberlein, H. (2006, July). Comparative study of European Covered Bonds. Technical report, Fitch Ratings.
- [436] Seow, H.V. and Thomas, L.C. (2006). Using adaptive learning in credit scoring to estimate take-up probability distribution. *European Journal of Operational Research*, **173**, 880–892.
- [437] Sercu, P. and Uppal, R. (1995). *International financial markets and the firm*. Current issues in finance. South Western College Publishing, Cincinnati, Ohio.
- [438] Setty, G. and Dodd, R. (2003). Credit rating agencies: their impact on capital flows to developing countries. Technical Report Special Policy Report 6, Financial Policy Forum, Derivatives Study Center.
- [439] Sharpe, W.F. (1964). Capital asset prices: A theory of market equilibrium under conditions of risk. *Journal of Finance*, **19**(3), 425–442.
- [440] Sharpe, W.F. (1966). Mutual fund performance. *Journal of Business*, **39**, 119–138.

- [441] Sharpe, W.F. (1994, Fall). The Sharpe ratio. *Journal of Portfolio Management*, **21**(1), 49–58.
- [442] Sharpe, W.F. (1999). *Portfolio theory and capital markets*. McGraw-Hill, London.
- [443] Shearer, C. (2000). The CRISP-DM model: the new blueprint for data mining. *Journal of Data Warehousing*, **5**(4), 13–22.
- [444] Shin, Y.S. and Moore, W.T. (2003). Explaining credit rating differences between Japanese and US agencies. *Review of Financial Economics*, **12**, 327–344.
- [445] Shiryaev, A.N. (1999). *Essentials of stochastic finance: facts, models, theory*. World Scientific, Singapore.
- [446] Siddiqui, S.H. (1994). *Islamic banking: genesis & rationale, evaluation & review, prospects & challenges*. Royal Book Co., Karachi, Pakistan.
- [447] Sinclair, T.J. (2005). *The new masters of capital: American bond rating agencies and the politics of creditworthiness*. Cornell University Press, Ithaca, NY.
- [448] Sinkey, J.F. (1998). *Commercial bank financial management* (5th edn). Prentice Hall, Harlow.
- [449] Smith, R.C. and Walter, I. (2002). Rating agencies: is there an agency issue? In *Ratings, rating agencies and the global financial system* (ed. R. Levich, G. Majnoni, and C. Reinhart), Kluwer, Dordrecht, The Netherlands, pp. 289–318.
- [450] Soberhart, J.R. and Keenan, S.C. (2002, February). The need for hybrid models. *Risk*, 73–77.
- [451] Sortino, F. and Price, L. (1994, Fall). Performance measurement in a downside risk framework. *Journal of Investing*.
- [452] Standard & Poor's (2006). *Corporate ratings criteria*.
- [453] Standard & Poor's Risk Solutions (2005, October). LossStats database user guide. Technical report, Standard & Poor's.
- [454] Stanghellini, E., McConway, K.J., and Hand, D.J. (1999). A chain graph for applicants for bank credit. *Journal of the Royal Statistical Society, Series C*, **48**, 239–251.
- [455] Steenackers, A. and Goovaerts, M.J. (1989). A credit scoring model for personal loans. *Insurance: Mathematics and Economics*, **8**, 31–34.
- [456] Stepanova, M. and Thomas, L.C. (2002). Survival analysis methods for personal loan data. *Operations Research*, **50**(2), 277–289.

## 514 References

- [457] Stevens, A., Den Dekker, T., Shamieh, C., and Tadros, R. (2001, November). European capital survey: From feast to famine? *Reactions*.
- [458] Stone, B. (1984). *Successful direct marketing methods*. Crain Books, Chicago.
- [459] Stone, M. and Woodcock, N. (1996). *Relationship marketing*. Kogan Page, London, UK.
- [460] Suykens, J.A.K., Van Gestel, T., De Brabanter, J., De Moor, B., and Vandewalle, J. (2002). *Least squares support vector machines*. World Scientific, Singapore.
- [461] Sy, A.N.R. (2004). Rating the rating agencies: Anticipating currency crises or debt crises? *Journal of Banking and Finance*, **28**, 2845–2867.
- [462] Taffler, R.J. and Abassi, B. (1984). Country risk: A model for predicting debt servicing problems in developing countries. *Journal of the Royal Statistical Society, Series A*, **147**(4), 541–568.
- [463] Taffler, R.J. (1984). Empirical models for the monitoring of UK corporations. *Journal of Banking and Finance*, **8**, 199–227.
- [464] Taillon, R.B. (2004). Banks seldom rated above the sovereigns. Technical report, Standard & Poor's.
- [465] Takahashi, K., Kurokawa, Y., and Watase, K. (1984). Corporate bankruptcy prediction in Japan. *Journal of Banking and Finance*, **8**, 229–247.
- [466] Tam, K.Y. and Kian, M.Y. (1992). Managerial applications of neural networks: the case of bank failure predictions. *Management Science*, **38**(7), 926–947.
- [467] Tamari, M. (1966). Financial ratios as a means of forecasting bankruptcy. *Management International Review*, **4**, 15–21.
- [468] Tasche, D. (2002). Expected shortfall and beyond. *Journal of Banking and Finance*, **26**(7), 1519–1533.
- [469] Taylor, S. (1986). *Modelling financial time series*. John Wiley, New York.
- [470] The Joint Forum (2001, July). Compendium of documents produced by the Joint Forum. Technical report, The Joint Forum: Basel Committee on Banking Supervision, International Organisation of Securities Commissions, International Association of Insurance Supervisors, Basel, Switzerland.
- [471] The Joint Forum (2001, November). Risk management practices and regulatory capital, cross-sectoral comparison. Technical report, The

Joint Forum: Basel Committee on Banking Supervision, International Organisation of Securities Commissions, International Association of Insurance Supervisors, Basel, Switzerland.

- [472] The Joint Forum (2003, August). Trends in risk integration and aggregation. Technical report, The Joint Forum: Basel Committee on Banking Supervision, International Organisation of Securities Commissions, International Association of Insurance Supervisors, Basel, Switzerland.
- [473] The Joint Forum (2006, May). The management of liquidity risk in financial groups. Technical report, The Joint Forum: Basel Committee on Banking Supervision, International Organisation of Securities Commissions, International Association of Insurance Supervisors, Basel, Switzerland.
- [474] Thomas, L.C. (2000). A survey of credit and behavioural scoring: forecasting financial risk of lending to consumers. *International Journal of Forecasting*, **16**, 149–172.
- [475] Thomas, L.C., Edelman, D.B., and Crook, J.N. (2002). *Credit scoring and its applications*. Monographs on Mathematical Modeling and Computation. SIAM, Philadelphia, US.
- [476] Thomas, L.C., Ho, J., and Scherer, W.T. (2001). Time will tell: Behavioural scoring and the dynamics of consumer risk assessment. *IMA Journal of Management Mathematics*, **12**, 89–103.
- [477] Thorburn, K. (2000). Bankruptcy auctions: Costs, debt recovery and firm survival. *Journal of Financial Economics*, **58**, 337–368.
- [478] Townsend, R. (1979). Optimal contracts and competitive markets with costly state verification. *Journal of Economic Theory*, **21**, 1–29.
- [479] Treacy, W.F. and Carey, M. (1998). Credit risk rating at large US banks. *Federal Reserve Bulletin* (84), 897–921.
- [480] Treynor, J.L. and Black, F. (1973, January). How to use security analysis to improve portfolio selection. *Journal of Business*, 66–85.
- [481] Truglia, V., Fons, J.S., Cailletau, P., and Mahoney, C.T. (2005, November). Revised policy with respect to country ceilings. Technical report, Moody's Investors Service, New York.
- [482] Uyemura, D. and Van Deventer, D. (1992). *Financial risk management in banking*. Probus Publishing Company, Chicago, USA.
- [483] van den Brink, G.J. (2002). *Operational risk*. Palgrave, New York.

- [484] Van den Poel, D. and Leunis, J. (1998). Database marketing modeling for financial services using hazard rate models. *International Review of Retail, Distribution and Consumer Research*, **8**(2), 243–257.
- [485] van Deventer, D.R. and Imai, K. (2003). *Credit risk models and the Basel accords*. Wiley Finance, Hoboken, New Jersey.
- [486] van Deventer, D., Imai, K., and Mesler, M. (2004). *Advanced financial risk management: tools and techniques for integrated credit risk and interest rate management*. John Wiley & Sons, Hoboken, New Jersey.
- [487] Van Gestel, T., Baesens, B., Suykens, J.A.K., Van den Poel, D., Baestaens, D., and Willekens, M. (2006). Bayesian kernel based classification for financial distress detection. *European Journal of Operational Research*, **172**, 979–1003.
- [488] Van Gestel, T., Baesens, B., Van Dijke, P., Garcia, J., Suykens, J., and Alderweireld, T. (2005). Linear and nonlinear credit scoring by combining logistic regression and Support Vector Machines. *Journal of Credit Risk*, **1**(4), 31–60.
- [489] Van Gestel, T., Baesens, B., Van Dijke, P., Garcia, J., Suykens, J.A.K., and Vanthienen, J. (2006). A process model to develop an internal rating system: sovereign credit ratings. *Decision Support Systems*, **42**(2), 1131–1151.
- [490] Van Gestel, T., Baesens, B., and Vanthienen, J. (2004). Bazel II, impact op IT. *Tijdschrift voor informatie*, **46**(10), 50–55.
- [491] Van Gestel, T., Espinoza, M., Baesens, B., Suykens, J.A.K., Brasseur, C., and De Moor, B. (2006). A Bayesian nonlinear Support Vector Machine Error Correction Model. *Journal of Forecasting*, **25**, 77–100.
- [492] Van Gestel, T., Suykens, J.A.K., Baesens, B., Viaene, S., Vanthienen, J., Dedene, G., De Moor, B., and Vandewalle, J. (2003). Benchmarking Least Squares Support Vector Machine classifiers. *Machine Learning*, **54**(1), 5–32.
- [493] Van Rixtel, A. (2002). *Informality and monetary policy in Japan: The political economy of bank performance*. Cambridge University Press, Cambridge.
- [494] Vanden Branden, K. and Hubert, M. (2005). Robust classification in high dimensions based on the SIMCA method. *Chemometrics and Intelligent Laboratory Systems*, **79**, 10–21.
- [495] Vapnik, V. (1998). *Statistical learning theory*. Wiley, New York.

- [496] Varma, P. and Cantor, R. (2005, June). Bond prices at default and at emergence from bankruptcy for US corporate issuers. Special comment, Moody's.
- [497] Vasicek, O. (1991). Limiting loan loss probability distribution. Technical report, KMV Corporation.
- [498] Vasicek, O. (1997, October). Credit valuation. *Net Exposure*.
- [499] Vasicek, O. (2002, December). Loan portfolio value. *Risk*, **15**(12), 160–162.
- [500] Vazza, D., Aurora, D., and Schneck, R. (2006, January). Annual global corporate default study and rating transitions. Technical report, Standard & Poor's, Global Fixed Income Research.
- [501] Viaene, S., Baesens, B., Van Gestel, T., Suykens, J.A.K., Van den Poel, D., Vanthienen, J., De Moor, B., and Dedene, G. (2000). Knowledge discovery using Least Squares Support Vector Machine classifiers: a direct marketing case. In *Lecture notes in artificial intelligence (Proc. PKDD 2000)* (ed. J. Zighed, D.A. Komorowski, and J. Zytchow), Springer Heidelberg / Berlin, Volume 1910, pp. 880–892.
- [502] Viaene, S., Baesens, B., Van Gestel, T., Suykens, J.A.K., Van den Poel, D., Vanthienen, J., De Moor, B., and Dedene, G. (2001). Knowledge discovery in a direct marketing case using Least Squares Support Vector Machines. *International Journal of Intelligent Systems*, **16**(9), 1023–1036.
- [503] Viaene, S., Derrig, R., Baesens, B., and Dedene, G. (2002). A comparison of state-of-the-art classification techniques for expert automobile insurance fraud detection. *Journal of Risk and Insurance*, **69**(3), 433–443.
- [504] Vink, D. (2007). *Primary Market Spreads of Asset Securitization Issues: Empirical Investigation and Analysis*. Ph. D. thesis, Nyenrode Business University.
- [505] Wagster, J.D. (1996). Impact of the 1988 Basel Accord on International Banks. *Journal of Finance*, **51**(4), 1321–1346.
- [506] Wang, L. (ed.) (2005). *Support Vector Machines: theory and applications*, Volume 177 of *Studies in Fuzziness and Soft Computing*. Springer.
- [507] Ward, L.S. and Lee, D.H. (2002, Summer). Practical application of the risk-adjusted return on capital framework. Dynamic financial analysis discussion papers, CAS Forum.
- [508] Weatherford, J. (1998). *The history of money*. Three Rivers Press, New York.

- [509] Wheelock, D.C. and Wilson, P.W. (2000). Why do banks disappear? The determinants of US bank failures and acquisitions. *Review of Economics and Statistics*, **82**(1), 127–138.
- [510] White, L.J. (1991). *The S&I debacle: public policy lessons for bank and thrift regulation*. Oxford University Press, NY.
- [511] White, L.J. (2002). The credit rating industry: An industrial organization analysis. In *Ratings, rating agencies and the global financial system* (ed. R. Levich, C. Reinhart, and G. Majnoni), Kluwer, Boston.
- [512] Wiginton, J.C. (1980). A note on the comparison of logit and discriminant models of consumer credit behaviour. *Journal of Financial and Quantitative Analysis*, **15**, 757–770.
- [513] Wilcox, J.W. (1971). A simple theory of financial ratios as predictors of failure. *Journal of Accounting Research*, **9**(2), 389–395.
- [514] Wilde, T. (2000). Creditrisk<sup>+</sup>. In *Credit derivatives and credit linked notes* (2nd edn) (ed. S. Das), John Wiley & Sons, New York, pp. 589–619.
- [515] Wilkinson, G. (1992). How credit scoring really works? In *Credit scoring and credit control* (ed. L. Thomas, J. Crook, and D. Edelman), Oxford University Press, Oxford, pp. 141–160.
- [516] Willis, M. and Saegesser, B. (2003 Second Quarter). XRBL: Streamlining credit risk management. *The Credit & Financial Management Review*.
- [517] Wilmarth, A.E. (2002). How should we respond to the growing risks of financial conglomerates? In *Banking law: financial modernization after Gramm-Leach-Bliley* (ed. Patricia A. McCoy), Lexis Nexis, Newark, New Jersey, pp. 65–133.
- [518] Wilson, T. (1997, September). Portfolio credit risk (I). *Risk*, **10**(9), 111–117.
- [519] Wilson, T. (1997, October). Portfolio credit risk (II). *Risk*, **10**(10), 56–61.
- [520] Wolcott, R. (2004). CDOs come of age. *Risk Magazine*, 24–26.
- [521] Zavgren, C. (1983). The prediction of corporate failure: the state of the art. *Journal of Accounting Literature*, **2**, 1–37.
- [522] Zavgren, C.V. (1985). Assessing the vulnerability to failure of American industrial firms. *Journal of Business, Finance and Accounting*, **12**(1), 19–45.
- [523] Zavgren, C.Y. (1985). The prediction of corporate failure: the state of the art. *Journal of Accounting Literature*, **2**, 1–37.

# Index

---

Note: page numbers in *italics* refer to Figures and Tables.

- acceptance of risk 41–2
- acceptance scoring 96–7
- Accord Implementation Group (AIG),
  - BCBS 57–8, 462
- accountancy data 235–6, 244
- accountancy measure 341
- accounting disclosure 433–4
- Accounting Task Force (ATF), BCBS 58–9
- accuracy 165–7
- acquisitions 328
- activity measures 244, 245
- advanced internal-ratings-based approach (IRBAa) 374
  - see also* internal-ratings-based approach
- advanced measurement approach (AMA) 416–18
- adverse selection bias 12
- affirmation of ratings 118
- agency factoring 81
- aggregation 333–9
- agricultural credit co-operations 7
- alternative standardized approach (ASA) 416
- A.M. Best 151
- American options 71
- American Stock Exchange (AMEX) 60
- amortized cost 227
- analytical portfolio models 293
- annuities 65
- application fraud scoring 99
- application of models 173, 265–6, 326–7
- application score variables 248, 249
- application scoring 94, 95, 97–9, 100, 103, 107
- arbitrage theory 196
- arranger 79
- Asian options 71
- ask price 60
- asset-based securities (ABS) 79–80
- asset classes 375–8
- asset correlation 317–19, 322–3
- asset liability management (ALM) 51
- asset management 16
- asset quality, banks 246
- assets (activa) 17, 18, 19–20
- asset transformation function of banks 10–12
- asset value 294
- asymmetric information 12
- asymptotic risk factor models (ARFM) 313
- attrition scoring 104
- audit 402
- audit subgroup, ATF 58
- automated credit ratings 97–8, 113, 166
- automated models 173
- averages 238–40
- avoidance of risk 41
- backtesting 174, 203, 253, 264, 267, 269–72, 306, 408, 413–14, 444
- balance sheet 17–21, 18
- balloon (bullet) loans 62–3
- Banco della Piazza di Rialto 5
- bank, origin of word 4
- Bank of Bengal 6
- bank capital 350–3
- bank capital management 353–4
- Bank of Credit and Commerce International (BCCI) failure (1991) 87
- bank debt 68
- Bank of England 5
- bank exposures 377, 378–92
- bank failures and crises 7–9, 84–91
- banking book interest rate risk 35, 427, 441
- banking book 31, 35, 427, 441
- banking history 2–9
- banking risk reserves 20
- Bank for International Settlements (BIS) 9, 54–5
- bank intracorrelations 337
- bank management 51–2
- Bank of New England failure (1991) 87–8
- Bank of New York 6
- bank notes 6
- bank profitability 478
- bank rating systems 157–8
  - see also* rating systems
- bank regulation 52–3, 55–9
  - see also* Basel II Capital Accord
- bank runs 35, 84
- bankruptcy 4, 91, 207



- bankruptcy databases 211–12
- bankruptcy prediction 100–1
- banks 1, 9–10, 12–17, 245, 360, 361, 246, 455, 457, 465–6
- Bank of Sweden 5
- Barings Bank failure (1995) 33, 91, 140
- barrier options 71
- Basel Committee on Banking Supervision (BCBS) 55–7
- Basel Core Principles (BCP) 463
- Basel IA rules 461
- Basel I Capital Accord (1988) 57, 344–5
- Basel II Capital Accord (ICCMCS 2006) xi, 23, 29, 33, 57, 345–50
  - bank capital 350, 353–4
  - chronology 346
  - credit risk parameters 358
  - criteria for credit rating agencies 155, 156
  - default definition 203, 206–8
  - evolution 478, 479–82
  - information technology aspects 441–52
  - internal ratings 159, 162
  - market impact 452–79
  - pillar 1 (minimum capital requirements) 354–6
  - pillar 2 (supervisory review process) 418–20
  - pillar 3 (market discipline) 431–41
- Basel II portfolio model 312–13, 327
  - asset correlations 317–19
  - double default framework 321–5
  - maturity adjustment 319–21
  - one-factor model 313–17
- basic indicator approach (BIA) 415
- basis risk 36
- Baycorp Advantage 109
- Bayesian networks 186
- behavioral risk 20
- behavioral scoring 100, 101–2, 103, 107, 248–9
- Belgium 6
- benchmarking 269, 271–2
- Bermudan options 71
- Bernoulli mixture portfolio models 293
- biases 152, 166, 192–3, 229, 254
- bias term, linear models 182
- bid-ask spread 60–1
- bid price 60
- bilateral risk, counterpart default 231
- bills 67
- binary classification problems 187, 188, 189
- binary indicators 237
- binary (digital) options 71
- binomial expansion technique 312
- BKR 109
- Black–Scholes formula 176, 216, 409
- bonds 19, 60, 63–7, 215, 301–4
  - fair value 227
  - interest rate risk 30
  - remarketing 83
  - risk specifications 31
- bootstrap 302
- bottom-up portfolio models 293
- brokerage function of banks 10, 13
- buffer capital 112
- building societies 6, 15
- bullet (balloon) loans 62–3
- business cycle 131
- business objectives, credit scoring 112–13
- business risk 37, 51, 52, 329
- 5 Cs of credit scoring 94, 113, 248
- calibration 93, 126, 170, 191, 193, 253, 254, 257, 259–60
  - backtesting 270–1
  - default risk 199, 260–1
  - exposure risk, credit conversion factor 262
  - loss risk 200, 261–2, 403
  - portfolio models 305–6
  - validation 268
- callable bonds 66
- call options 36, 70, 71, 74
- CAMEL variables 245, 246
- Canadian Dominion Bond Rating Service 151, 157
- capital 56–7, 245, 246, 259, 284, 327, 339–41, 343, 425–6, 436–7, 447
  - capital adequacy 56–7, 245, 246, 425–6, 436–7
  - capital allocation 339–41
  - capital assets pricing model (CAPM) 343
  - capital calculation engine 447
  - capital charge (CC) 355, 398
  - capital deficiencies 436
  - capital multiplier 284
  - capital ratios 344
  - capital requirements 259, 327
- Capital Requirements Directive (CRD) 459–61
- Capital Task Force (CTF), BCBS 58
- caps 74
- cash flow analysis 178–9
- cash flows 218–22, 236, 246
- catastrophe risk 328
- central banks 16, 358, 360–1
- Chase National Bank 8
- cherry-picking 154, 365
- Cholesky factorization 297–8
- City Bank 8
- CKP 109
- claim fraud scoring 99
- claims payability 138
- classification problems 187, 188, 189
- clearing systems 6–7
- cohort method 205, 229
- collateral 27, 42, 63, 195, 373–4, 380–3, 362, 473
- collateralized debt obligations (CDOs) 79, 80, 311–12
- collateralized transactions 367–71
- collection of data 171, 172, 202–3, 256, 325–6
- collection scoring 95, 104

- combined models 196–9
- commercial banks 13, 15
- commercial investments, deductions from bank capital 353
- commercial mortgages 362
- commodities 30
- commodities finance (CF) 376
- common solvency ratio reporting (COREP) framework 449
- common stocks 60
- comparability of credit ratings 147–8, 161, 166
- comparability of disclosures 435
- complexity 189–90, 259
- comprehensive approach 367–70
- computation engines 446–8
- concentration risk 287–91, 289, 428–9
- conceptual issues subgroup, ATF 58
- conditional default probability 295
- conditional portfolio models 292, 308–10
- conditional (shadow) ratings 120
- conditional VaR *see* expected shortfall
- confidence level 313
- confirmation of ratings 118
- conflicts of interest 154
- conglomerates 328–9, 330
- conservatism 259–60
- consistency 192, 214, 243, 400, 405, 445
  - data 243, 445
  - human expert judgement 192
  - model development 260, 268, 405
- consultancy activities of banks 15
- contagion 107
- Continental Illinois Bank failure (1984) 86
- continuous discount rate 221
- contractual support 430
- convertible bonds 66, 474
- core bank activities 13–14
- Core Principle Liaison Group, BCBS 59
- corporate exposures 378–92
- correlated asset realizations 297–9
- correlation 285–7, 289–91, 334–5, 337
- cost function 186–9
- costs, recovery process 219–20
- counterpart credit risk (CCR) 28, 230–4, 386, 429
- counterpart scores 106–8
- country bias 166
- country ceiling ratings 142–3, 144, 145, 213
- country credit ratings 124, 141–2
- covariance 281
- covenants 28, 42
- covered bonds 80, 475–6
- Cox processes 180
- creditability, credit rating agencies 156
- credit approval 93–4, 163
- credit bureaus 108, 109–11, 114
- credit card fraud scoring 99
- credit cards 63
- credit committees 42, 43
- credit conversion factor (CCF) 106, 195–196, 201, 228–9, 363–4
  - backtesting 271
  - calibration 262
  - downturn CCF estimation 253, 260, 262, 386, 393
  - IRBA 385–8
  - measurement 229–30
  - ratings 125, 133–4, 145
  - score function 106, 258
  - see also* Exposure at Default (EAD)
- credit culture types 43–4
- credit default swaps (CDSs) 75, 76, 196, 197, 216, 321
- credit derivatives 75–6, 83, 372
- credit enhancement 43
- credit limits 28
- credit lines 63
- credit-linked notes 76
- CreditMetrics portfolio model 306–7
- Credit Portfolio View model 306, 308–10
- credit ratings *see* ratings
- credit risk 24–9, 37, 38, 115, 356–7, 428–30
  - advanced internal-ratings-based approach (IRBAa) 374
  - capital charge 396
  - default risk 199, 260–1
    - see also* probability of default (PD)
  - exposure risk, credit conversion factor 262
    - see also* exposure at default (EAD)
  - foundation internal-rating-based approach (IRBAf) 374, 378
  - ICAAP 422
  - internal ratings-based approach (IRBA) 155, 157–8, 213, 357, 374–5
  - loss risk 200, 261–2, 403
    - see also* loss given default (LGD)
  - management 42–4
  - parameters 358
  - standardized approach (SA) 357–74
    - see also* risk, Basel II
- CreditRisk<sup>+</sup> portfolio model 306, 310–11
- credit scoring 93–5, 96, 168
  - application score 97–9, 103
  - attrition score 104
  - behavioral score 101–2, 103
  - business objectives 112–13
  - collection score 104
  - counterpart score 106–7
  - early warning score 102–3
  - external score 108–9
  - facility score 106–7
  - fraud score 99
  - internal score 108–9
  - limitations 113–14
  - marketing scores 96–7
  - overrides 111
  - performance score 99–101
  - profit score 105
  - relation to rating systems 117–18

## 522 Index

- credit scoring (*cont.*)
    - score target 105–6
    - score types 106–9
  - credit spread 30
  - credit spread forwards 76
  - credit spread options 76
  - Cross-Border Banking Group, BCBS 59
  - cross-border communications 431
  - cumulative default rates 127, 128
  - cure 26
  - currency risk 29–30, 38
  - current discount rates 220–1
  - current exposure (replacement cost) 231, 233
  - custodian banks 16
  - customer deposits 20
  - customer information 249
  - customer loans 19
  - customer relation measures 249
  
  - Danish mortgage bonds 430
  - data 201–3, 202
    - data cleaning 256
    - data definition and collection 171–2
    - data delays 239, 242
    - data management 442–6
    - data memorization risk 189
    - data mining 186
    - data-pooling 108
    - data quality 113, 445
    - data sources 243–4
    - data standardization 445–6
    - data storage requirements 401
    - data transfer 448
    - data validation 268
    - data warehouses 449–51
  - default information 203–6, 211–12
    - default definitions 203, 403
    - external ratings 212–14
    - internal expert ratings 214
    - market information 214–16
  - explanatory variables 234–5
    - absolute and relative information 237–8
    - qualitative 236–7
    - quantitative 235–6
    - time aspects 238–42
    - variable definition 242–3
  - exposure at default 226–8
    - counterpart credit risk 28, 230–4
    - credit conversion factor 228–9
    - EAD & CCF measurement 229–30
  - loss given default information 217–18
  - expected loss approach 225–6
  - market-implied LGD 225
  - market LGD 224–5
  - recovery ratings 226
  - workout LGD 218–24
- low data availability 172, 179
    - human expert judgements 193–4
    - use of generic scorecards 251
    - portfolio models 325–6
  - databases 202, 211–12, 243–4, 255–7, 265, 449–51
  - debt 12, 13, 61–2
    - bank debt 68
    - bonds 63–7
    - leasing 68
    - liabilities 20, 249
    - loans, mortgages and revolving credits 62–3
    - ratios 246
    - securities 20, 367
    - seniority structure 27
    - structuring, role of credit ratings 164–5
  - decision trees 186
  - deductions from bank capital 350–1, 352–3
  - default
    - definition 203, 403
      - Basel II 206–8, 428
      - internal 208, 210–12
      - rating agencies 208, 209
    - detection 205
    - defaulted borrowers grades 160, 162
    - double default 322–5
    - emergence 205
    - type 205
  - default correlation 291
  - default intensity, reduced form models 180
  - default-mode portfolio models 292, 304
    - CreditMetrics 307
    - KMV Portfolio Manager 307–8
    - Vasicek one-factor model 294–7
  - default rate 126
  - default risk (PD) *see* probability of default (PD)
  - delinquency definitions 208–12
  - delivery-versus-payment systems 364
  - delta equivalent notional value 386
  - delta (marginal) VaR 284
  - delta-normal method, VaR 410
  - demographic information 247, 248–249
  - dependence modelling 291
  - dependent (target) variables 181
  - deposit protection 53–4
  - deposit ratings 139
  - derivative information 236
  - derivatives 46, 68–9
    - credit derivatives 75–6
    - equity derivatives 75
    - exposure at default 228
    - exposure risk 28
    - fixed-income derivatives 74
    - forward contracts 69–70
    - futures 70
    - options 70–3
    - swaps 73
    - warrants 73
  - design criteria 252–4
  - development of models 252
    - choice of model type 251

- database construction and preprocessing 255–7
- design criteria 252–4
- documentation 263–4
- modelling 257–62
- digital (binary) options 71
- dilution risk capital charge 396–7
- direct costs, recovery process 219
- disclosure
  - capital structure 436
  - credit rating agencies 156
  - general minimum requirements, IRBA 405
  - recommendations 432–5
  - requirements 435–41, 460, 470
- discount rates 220–1
- discounts, purchased receivables 397
- discriminant score, default data 203, 205
- discriminative power 253
- distance to default (DD) 178–9
- distressed exchange, definition 209
- distressed form, timeline 204
- distressed recovery ratings 132
- diversification 11, 41–3, 273, 291, 331
- diversification benefits (DB) 284, 334–8
- dividends 60
- documentation 263–4, 401, 405
- dollar duration 50
- domestic bonds 64
- double counting effects 347
- double default formula, Basel II 384–5
- double default framework, Basel II portfolio model 321–5
- double entry bookkeeping 17
- double leverage 340, 353
- Dow Jones Industrial average index 61
- downgrade overrides 111, 127, 130–1
- downturn estimation 200, 253, 260–8, 314, 386, 393
- dual currency bonds 65
- Duff & Phelps 150
- Dun & Bradstreet Corp (D&B) 109, 150
- Du Pont chart 21, 23
- duration 30, 49–50
- duration dependence effect, default rates 131
- early amortization 430
- early warning systems 102–3, 265
- earning multiple (PE ratio) 61
- earnings, banks 246
- earnings-at-risk 282
- East India trade 5
- economic capital (EC) 279, 284, 327, 328
  - calculations 112, 164
  - goals 331–2
  - portfolio models 327
  - risk-level aggregation 334–9
  - silos aggregation 333–4
- economic cycle, effect on credit ratings 146–7
- economic loss 217
- economies of scale 10, 328, 332
- economy, impact of Basel II 476–9
- effective expected exposure (Eff.EE) 232, 233
- effective expected positive exposure (Eff.EPE) 232, 233, 388
- effective maturity, IRBA 390–4
  - corporate, sovereign and bank exposures 390–2
  - equity exposures 394
  - retail exposures 393
- effective number of parameters 189
- eligibility, collateral 367
- emergence of default 207, 222
- emerging markets 463–5
- empirical statistical models 172, 174, 175, 181–2
  - complexity 189–90
  - cost function 186–8
  - data requirements 201
  - evaluation 190–1
  - model structure 182–6
- employers, use of credit scores 113
- employment practices, operational risk 31, 32
- entities 436
- entrepreneurial risk 37
- entry barriers 155
- Equal Credit Opportunities Act (1976) 98
- Equal Opportunities Act 243
- Equifax 109
- equities 12–13, 19, 60–1, 228, 367, 441, 455, 457–8, 474
  - derivatives, options, swaps 75
  - exchanges 69
  - exposures 378, 393–5
  - information 236
  - investments, deduction from bank capital 353
  - multiplier 21, 53
  - prices 215–16
  - risk 29, 408
- equivalent number of loans 289
- ethical considerations 98–9, 243
- Euler's lemma 340
- Euribor 19, 74
- Eurobonds 65
- Eurodollar futures 74
- Euronext 60
- European Capital Requirement Directive 375
- European option 71
- European Union 459–61
- Euroswiss futures 74
- Euroyen futures 74
- evaluation 42, 190–1, 262
- exchange rate risk haircut 368–9, 373–4
- exchange-traded derivatives 69, 230
- exercise price 70
- exercise time 71
- expected default frequency (EDF) 178
- expected exposure (EE) 232, 233
- expected loss (EL) 278–9
  - individual loans 275
  - loss ratings 124, 125, 134–7, 145

- expected loss (EL) (*cont.*)
  - loss risk 115
  - Merton model 178
  - portfolios 277
- expected loss approach, LGD 218, 225–6
- expected positive exposure (EPE) 232, 233
- expected (preliminary) ratings 120
- expected shortfall (ES) 279, 285
- expected tail loss *see* expected shortfall
- Experian 108, 109
- expert evaluation, empirical statistical models 191
- expert human judgement 191–4, 196–9, 214, 235
- expert models 174, 175, 191, 257–8
- explanatory variables 181, 202, 234–5
  - absolute and relative information 237–8
  - averages 238–40
  - database construction 256
  - data delay and prediction horizon 239, 241–2
  - data sources 243–4
  - examples 244–51
  - most recent value 238
  - past value 238
  - qualitative 236–7
  - quantitative 235–6
  - trends 240–1
  - variable definition 242–3
- see also* data
- explicit prediction horizon 241
- exponentially moving averages 240
- exponential transformations 183
- export credit agencies (ECAs) 360
- exposure at default (EAD) 28–9, 106, 133–4, 222, 226–8, 275
  - corporate, sovereign and bank exposures, IRBA 385–6
  - internal models method 388, 390
  - standardized method 386–8, 389
  - counterpart credit risk 28, 230–4
  - credit conversion factor 228–9
  - data 202–3, 251, 442
  - downturn 253, 260–4, 386, 393
  - EAD modelling 201
  - equity exposures, IRBA 395
  - exposure ratings 133–4, 147
  - measurement 229–30, 403–4
  - retail exposures 393
  - risk 107, 114
- exposure categorization, credit risk 359
- exposure measures, counterpart credit risk 232–3
- extensible business reporting language (XBRL) 443–4, 449
- external costs, recovery process 219, 220
- External Credit Assessment Institutions (ECAI) 212, 357
- external credit ratings 116, 117, 118, 147
  - see also* rating agencies
- external credit scoring systems 108
- external fraud 31
- facility scores 106–8
- factoring 81–2, 472
- failed trades 364–5
- Fair Isaac 108, 110
- fair value 227, 302–3
- Fama–French factors 216
- fat-tailed distribution functions 277
- feasibility constraint 286
- Federal Deposit Insurance Corporation (FDIC) 8
- federal deposit insurance, US 84
- Federal Reserve 8
- fees 153, 154, 167
- Financial Accounting Standards Board (FASB) 58
- financial collateral 367
- financial crises 55
- financial efficiency 54
- financial enhancement ratings 138
- financial guarantors 79, 83, 92, 322–5
- financial instruments disclosure subgroup, ATF 58
- financial lease agreements 68
- financial models 174–6, 175
  - gambler's ruin model 178–9
  - Merton model 176–8
  - reduced form models 180–1
- financial products 59–60
  - debt 61–3, 63–7, 68
  - derivatives 68–76
  - equity 60–1
  - factoring 81–2
  - guarantees 83, 92
  - liquidity facilities 82–3
    - letters of credit (L/C) 82–3
    - stand-by bond purchase agreements 83
  - mutual funds 82
  - structured 76–81
- financial ratios 181–2, 235, 238, 241, 244, 264
- financial risk 1, 51, 52
- Financial Stability Forum (FSF) 59
- financial variables 235
  - for banks 245, 246
  - for firm counterparts 245
  - for insurance companies 244–5, 246
  - for local governments 247
  - for public sector entities 247–8
  - for retail customers 248–9
  - for sovereign counterparts 247, 248
- FINREP 449
- firms 65, 124, 244, 245, 317, 361, 376, 378, 402, 455, 457, 471–2
- firm-wide economic capital 329–33
- Fisher discriminant analysis (FDA) 188
- Fitch Ratings, Ltd. 108, 115, 121–3, 132, 139, 140–1, 150–3, 157, 208, 209
- Fitch, John Knowles 150
- Fitzpatrick 181, 182
- fixed-coupon bonds 65, 301
- fixed-income derivatives 74

- fixed-income securities 19, 62
- fixed time horizon 229
- flash volume variables 249
- floating-rate notes (FRN) 65
- Florence 4
- flow variables 236, 249
- fluctuation, default rates 128
- follow-up of models 173–4, 266
- foreign bonds 65
- foreign currency ratings 137, 366
- forward contracts 69–70, 76
- forward rate 302
- forward rate agreements (FRAs) 74
- foundation internal-rating-based approach (IRBAf) 374, 378
  - see also* internal-ratings-based approach
- fractional reserve 17
- France 7
- fraud 31
- fraud scoring 99
- free-delivery transactions 364
- frequency of disclosure 434–5
- Fugger family 4, 27
- full branch equivalency 141
- future contracts (futures) 70, 74, 75
  
- gambler's ruin model 175, 178–9
- gap analysis 46, 49, 50
- Generalized Accepted Accounting Practices (GAAP) 242–3
- general provisions 351
- generic models 251
- Germany 7, 9
- giro systems 8
- Glass–Steagall Act 8
- global ICT architecture 449–52, 450
- global models 237–8
- gold 29
- goodwill, deduction from Tier I capital 350, 352
- government (agency) bonds 65
- government support 139–40, 144
- grade numbers, bank ratings 160, 162, 399
- granularity 286–7, 361
- graphical models 186, 196–7
- Great Crash (1929) 8
- Great Depression 84, 140
- Gross Domestic Product (GDP) 247, 248
- group capital 339
- group ratings 366
- growth variables 244, 245
- guaranteed bonds 65
- guarantees 27, 83, 92, 321–2, 372
  - double default probability 322–5
  - general minimum requirements, IRBA 404–5
- guidance 55–9
  
- haircuts (HCs) 195, 200, 223–4, 367–70, 373–4
- harmonized risk measures 330–1
  
- hedging 29, 45–6, 51
  - exposure at default 228
  - perfect anticorrelation 286
- hedging sets 387
- Henry VIII, legalization of interest rates 4
- Herfindahl–Hirschman index (HHI) 288, 334
- Herstatt Bank failure (1974) 24–5, 84
- hierarchies, model use 264
- high-side overrides 111
- high-volatility commercial real estate (HVCRE) 376
- historical discount rates 220, 221
- historical scenarios 412
- historical simulation method, VaR 410
- holding ratings 366
- hold-to-maturity portfolio modelling 220, 292
- home equity loans 63
- Horrigan, J. 182
- human expert ratings 214
- human judgement 191–9, 235
- hybrid capital 20
- hybrid instruments 351
- hypothetical scenarios 412
  
- IBCA 150
- identification of risk 40
- immediate-performance driven strategy, credit risk management 44
- implementation aspects 365–6, 464–5, 469
- implementation of models 173, 264–5
  - portfolio models 325–6
  - risk management strategies 42
  - validation 268–9
- implicit prediction horizon 242
- implicit support 430
- implied-market LGDs 261
- Inca society 2
- income generation 21
- income-producing real estate (IPRE) 376
- income simulation 50–1
- incompleteness 333–4
- inconsistencies 333
- incremental credit risk (ICR) measures 411
- incremental economic capital (IEC) 284
- incremental VaR 283
- independent variables 181, *see also* explanatory variables
- index options 75
- India, development of banking 6
- indirect costs 219
- indirect models 194–6, 200
- industrial credit co-operations 7
- industrial revolution 6
- inflation 4–5, 248
- inflation-linked bonds 65–6
- information intermediation 12
- information provision 163
- information technology 441–2
  - computation engines 446–8

- information technology (*cont.*)
    - data management 442–6
    - documentation 263–4
    - global architecture 449–52
    - implementation 268
    - IT systems 173, 264
    - reporting 448–9
    - staging and data transfer 448
  - initial public offerings (IPOs) 60
  - input variables 181, *see also* explanatory variables
  - inquiry numbers, credit agencies 109–10
  - in-sample performances 191
  - installment credits 62–3
  - institutional investors, share holdings 61
  - institutional stability 272
  - insurance claims 99
  - insurance companies
    - financial variables 244–5, 246
    - insurance risk 33
    - investments, deductions from bank capital 353
    - ratings 138–9
    - risk management 331
    - risk types 328–9
    - share holdings 61
    - Solvency II 348
    - use of credit scores 113
  - insurance intracorrelations 337
  - interbank loans 19, 20
  - interest rate 62
    - bonds 215
    - disclosure 441
    - legalization in England 4
    - gap analysis 49, 50
    - internal market risk models 408
      - religious objections 3
    - risk 30, 35, 38, 49–51, 422, 427, 441
    - swaps 74
    - term structure 301
  - intermarket impact, Basel II 469
  - internal assessment approach 398
  - internal capital adequacy assessment process (ICAAP) 419, 420–5
  - internal control review 423–4
  - internal costs, recovery process 219, 220
  - internal credit ratings 117–18, 147
  - internal credit scoring systems 108–9
  - internal default definitions 208, 210–12
  - internal fraud 31
  - internal model approach (IMA) 407–14
  - internal models method 388–94
  - internal portfolio capital calculation engines 447–8
  - internal rating models 168–9
  - internal ratings-based approach (IRBA) 155, 157–8, 213, 357, 374–5
    - advanced approach 374
    - asset classes 375–8
    - corporate, sovereign and bank exposures 378–92
    - credit conversion factor 385–92
    - credit risk disclosures 438–9
    - effective maturity 390
    - exposure at default (EAD) 385–92
    - equity exposures 393–5
    - foundation approach 374
    - general minimum requirements
      - disclosure 405
      - documentation 401, 405
      - firm governance and oversight 402
      - guarantees 404–5
      - rating assignment horizon 400
      - rating criteria 399–400
      - rating structure 160, 399
      - rating system coverage 401–2
      - risk quantification 402–4
      - use of internal ratings 402
      - use of models 400–1
      - validation 405
    - loss given default (LGD) 380, 383–5
    - maturity (M) 390–2
    - minimum capital requirements 455
    - probability of default (PD) 260, 380, 392
    - retail exposures 392–3
    - securitization exposures 397–9
    - see also* Basel II
  - internal rating systems 172–3, 402
  - International Accounting Standard (IAS) 39, 58
  - International Accounting Standards Board (IASB) 58
  - International Association of Insurance Supervisors (IAIS) 59
  - International Auditing and Assurance Standards Board (IAASB) 58
  - International Financial Reporting Standards (IFRS) 243
  - International Organization of Securities Commissions (IOSCO) 59, 155
  - international trade 4
  - interval measures 249
  - in-the-money options 71
  - intramarket impact of Basel II 469–71
  - intrarisk diversification 335
  - intrinsically linear models 183
  - inverse floaters 65
  - investment banks 15–7
  - investment grade 126
  - “i” ratings 119
  - irrevocable letters of credit 83
  - issuer credit ratings 124, 126, 366
  - issuer recovery ratings 133
  - issue-specific credit ratings 124, 126, 366
  - issue-specific recovery ratings 133
  - iterative design 252, 255
- 
- Jankowitsch, R. *et al.* 174
  - Japan 7, 89–91, 462–3
  - JP Morgan 8
  - judgmental variables 198, 235, 237, 243

- jump processes 180
- junk bonds 126
  
- kernel-based models 185–6
- key risk indicators 46–7
- KMV 150
- KMV Credit Monitor 178
- KMV Portfolio Manager 306, 307–8
- knock-in (trigger) options 71
- knock-out options 71
- knowledge fusion 258
  
- Lamfalussy procedure 459
- leases 68, 228, 473
- least squares regression 200
- legal risks 31, 33
- Lehman Brothers 8
- letters of credit (L/C) 82–3, 195–6
- level 1 risk aggregation 334–5
- level 2 risk aggregation 335–6
- level 3 risk aggregation 336–9
- leverage 53, 245–6
- liabilities (passiva) 17, 18, 20
- Libor (London Interbank Offered Rate) 19
- life insurance 329, 331
- limitations 43, 113–4, 165–7
- limiting loan loss distribution 296
- limit systems 265, 326
- linear discriminant analysis 182
- linear model structures 182, 183
- lines of credit 63
- liquidation 24, 26, 27
- liquidity 30, 33–5, 48, 215, 245–6, 422
  - buffers 48, 246
  - facilities 82–3
  - gaps 33, 34, 49
  - intermediation 11
  - premium, bonds 215
  - ratios 245–6
  - reserve 17
  - risk 33–5, 38
  - risk assessment, ICAAP 422
  - risk management 47–9
  - spread 30
- loan accounting subgroup, ATF 58
- loan equivalent factor (LEQ) 228–30
- loans 2, 62–3, 98
- local bonds 65
- local currency ratings 137, 366
- local governments 247
- logarithmic transformation 183
- logistic link function 188
- logistic regression (logit) 182, 187, 188, 199
- Lombards 3–4
- London Stock Exchange (LSE) 5, 60
- long positions 61, 69–72
- Long Term Capital Management hedge fund (1998) 54
  
- long-term credit ratings 121–3, 151
- long-term investments 19
- long-term issuer default ratings 116
- loss distribution 274–7,
- loss evaluation 47
- loss given default (LGD) 26–8, 29, 106, 107, 131, 146, 275
  - backtesting 270
  - Basel II asset classes 380–5, 393–4
  - calibration 261–2
  - data 202–3, 250–1, 442
  - downturn 200, 250, 252, 260–1, 403
  - distribution 201, 305
  - empirical LGD calculation
    - cash-flow discounting 218–22
    - costs and payments 219–20
    - discount rate 220–1
    - end of workout 222
    - exposure at default 222
    - recoveries 218–19
    - timing 221
  - mapping function 314
  - Merton model 178
  - models 200, 258
  - PD-LGD correlation 261, 291
  - ratings 132, 145
  - risk data quantification 217–18, 403
    - expected loss approach 225–6
    - market-implied LGD 215–16, 225
    - market LGD 224–5
    - workout LGD 218–24
  - “white box” models 195
- loss risk 107, 235
- loss standard deviation (LSD) 279, 280–2
- low-side overrides 111
  
- McGraw–Hill Companies 150
- machine learning techniques 186
- macroeconomy 248, 272
- Main Bank system, Japan 462
- maintenance of models 266
- management supervision 421
- management quality 246
- mapping function 314
- mapping to ratings 147–8, 200, 212–14, 365
- margin accounts 369
- marginal loss standard deviation (MLSD<sub>f</sub>) 281–2
- marginal VaR 284
- margining agreements 231, 233, 234
- market-based approach, equity exposures 393–4
- market data 236, 248
- market discipline 431–5
- market impact, Basel II 459–75
- market-implied LGD 217–18, 225
- market-implied models 180–1
- market-implied ratings 152, 216, 261
- market information 214–16
- marketing 96–7, 110



- market LGD 217, 224–5
- market making activity 15
- market risk 29–31, 38, 331, 406
  - approaches 356
  - disclosure requirements 440
  - ICAAP 422
  - internal model approach (IMA) 407–11
  - liquidity risk 33
  - pillar 1 355
  - pillar 2 430–1
  - pillar 3 440
  - risk management 44–6
  - standardized approach 406–7
  - stress testing 411–13
- Markov chains, roll-rate analysis 210
- Markovian processes 127
- mark-to-market losses 220, 291, 292, 301–4, 307, 320
- masterscales 159, 161–2
- material adverse clauses 28
- material investments 350
- materiality thresholds 208, 353
- maturity (M) 64, 67, 388, 372, 390
  - Basel II asset classes 390–4
  - bonds 64, 67
  - EPE calculation 388, 390–2
  - effective maturity 390–4
  - mismatches 372–3
- maturity adjustment 319–21
- mean-variance efficient frontier 337–9, 338
- measurement of risk 39, 40
- Medici family 4
- medium-term credit ratings 121, 123
- Mercer 108
- merchant banks 15
- mergers 328
- Merton model 175, 176–8, 215, 257
- Mesopotamia, storage of money 2
- methodology 168–70, 174, 257–62, 326
- mezzanine financing 473
- mid price 60
- migration 127, 130–3
  - analysis 191
  - default ratings 127, 130–1
  - events 299–301
  - matrix 130, 300–1
  - recovery ratings 133
  - stability 272
- missing-value treatment 256
- mitigation 41, 366–7, 374, *see also* risk mitigation
- modelling 168–70, 174, 257–62
  - application 265–6
  - backtesting 269–72
  - benchmarking 269–72
  - combined models 196–9
  - development 252
    - choice of model type 251
    - database construction and preprocessing 255–7
    - design criteria 252–4
    - documentation 263–4
  - direct and indirect models 194–6
  - documentation 405
  - empirical statistical models 181
    - complexity 189–90
    - cost function 186–9
    - evaluation 190–1
    - model structure 182–6
  - expert models 191
  - financial models 174–6
    - gambler's ruin model 178–9
    - Merton model 176–8
    - reduced form models 180–1
  - follow-up 266
  - global models 237–8
  - implementation 264–5
  - model definition 267
  - performance 190–1, 331
  - role of credit ratings 164
  - model risk 266
  - quality control 269
  - rating system life cycle 170–4
  - structure 182–6
    - kernel-based models 185–6
    - linear models 182
    - intrinsically linear models 183
    - parametric models 182–4
    - neural networks 184
    - non-parametric models 185–6
  - techniques 175
    - default prediction 199, 200
    - EAD and CCF prediction 201
    - LGD prediction 200
  - use 400–1
  - validation 266–9
    - see also* data, portfolio models
- modified duration 49–50
- money 2, 54
- monitoring 59, 423
- monitoring of models 253, 264, 269
- monoliners 79, 83, 92
- monotonicity of risk measures 278
- Monte Carlo simulation 410
- Moody, John 149
- Moody's 108, 115, 121, 149–50, 157
- moral hazard bias 12
- moratorium risk 142
- Morgan Stanley 8
- mortgage-backed securities (MBS) 79, 475
- mortgage loans 63, 318, 362
- most recent values 238
- mother support 140, 141, 144, 213
- moving-average values 238–40
- multilayer perceptron (MLP) 183, 184–5
- multiple class indicators 237
- multisector collateralized debt obligations 80
- municipal ratings 139
- mutual funds 61, 82, 367

- naked (uncovered) options 71
- National Association of Securities Dealers
  - Automated Quotation System (NASDAQ) 60
- National Bank of Belgium 6
- national banks 5, 7
- Nationally Recognized Statistical Organizations 157
- national scale ratings 138
- negative outlook 119
- negative support 140, 141, 144
- net present value (NPV) 218, 225
- net profit 21
- net worth 17
- neural networks 184
- New-Keynesian framework 477
- new ratings 118
- New York 7–8
- New York Stock Exchange (NYSE) 60–1
- NiGEM model 477
- nominal yield 64
- non-consolidated investments 353
- non-disclosure 433
- non-parametric models 185–6
- non-recourse factoring 81
- Norwegian banking crisis (1988-1993) 86–7
- notching schemes 136, 145, 198, 214
- notes 67
- neural networks 184
- notional amount 68
  
- object finance (OF) 376
- objective data 235–6
- objectivity, credit rating agencies 156
- Occam's razor principle 190
- off-balance sheet items 363–5
- Ohlson, J.A. 182
- oligopolistic market structure 155
- on-balance sheet netting 372
- one-dimensional bank rating systems 158, 162
- one-factor models 294, 313–17
  - Basel II portfolio model 313–17
- operational defaults 205
- operational leases 68
- operational risk 1, 31–3, 38, 414–15
  - advanced measurement approach (AMA) 416–18
  - approaches 356
  - basic indicator approach (BIA) 415
  - disclosure requirements 440–1
  - pillar 2 431, 464
  - standardized approach (SA) 415–16
  - risk charge 355, 456
  - risk management 46–7, 48
- operational risk subgroup, AIG 57–8
- option pricing 215–16
- option risk 36–7, 408–9
- options 70–3, 74, 75, 76
- Order of Knights Templar 3
  
- ordinal classification problems 188
- ordinal multiple indicators 237
- ordinary least squares (OLS) regression 187, 200
- Organization for Economic Cooperation and Development (OECD) 358
- originator 79
- Other Assets Especially Mentioned (OAEM) 158
- outlier correction 256
- outlook 119
- out-of-the-money options 71
- overdraft facilities 63
- overdrafts 107, 206, 207
- overestimation of risk 259
- overfitting 186
- overrides 111, 144, 172, 198, 264, 401
- over-the-counter derivatives 69, 230
- over-the-counter stock markets 61
  
- 4 Ps, marketing score 97
- Papal bankers 4
- parallel yield-curve shift 413
- parameters, effective number 189
- par bonds 64
- Pareto optimum 13
- partial factoring 82
- partial use 357
- passthrough asset-backed securities 80
- past due loans 363
- past values 238
- pawnbrokers 5
- payment arrears 203
- payment moratorium 142
- payment-versus-payment systems 364
- pay-off structure 71–3, 72, 176, 177
- Pazzi family 4
- PD/LGD approach 394–5
- peak exposure (PE) 231–2
- penalty zones 414
- pension funds 61
- Peregrine Investment Holdings,
  - failure (1997) 91
- performance 190–1, 164, 331
- performance period 99
- performance ratios 246
- performance risk 51, 52
- performance scoring 99–101
- performance subgroup, ATF 58
- perpetual bonds 65
- Peruzzi family 4
- physical assets, operational risk 32
- pillar 1 (minimum capital requirements) 354–417
  - credit risk 292, 356–405
  - market risk 406–14
  - operational risk 414–18
  - see also* Basel II Capital Accord
- pillar 2 (supervisory review process) 418–30
  - credit risk 428–30
  - interest rate risk 427

- pillar 2 (supervisory review process) (*cont.*)
  - key principles 420, 420–7
  - market risk 430–1
  - see also* Basel II Capital Accord
- pillar 3 (market discipline) 431–41
  - capital 436
  - credit risk 438, 439–40
  - market risk 440
  - operational risk 440
  - qualitative disclosures 436, 437–8
  - quantitative disclosures 436, 437
  - scope of application 435
  - see also* Basel II Capital Accord
- “pi” ratings 119
- plain-vanilla options 73
- point-in-time (PIT) rating 145–8, 151, 152, 160, 260
- Poisson mixture 293
- political regime 248
- pooled data 256
- pool 392
- Poor, HenryVarnum 150
- population drift 114
- population stability 272
- portfolio invariant model 312
- portfolio loss distribution 276–7, 289–91
  - concentration effect 287–9
  - correlation effect 285–7
- portfolio models 273–4
  - Basel II model 312–13
    - asset correlations 317–19
    - double default framework 321–5
    - maturity adjustment 319–21
    - one-factor model 313–17
  - calibration 305–6
  - capital allocation 339–41
  - classification 292–4
  - comparisons 306
  - CreditMetrics 306–7
  - Credit Portfolio View 308–10
  - CreditRisk<sup>+</sup> 310–11
  - economic capital 327–8
    - aggregation and differentiation 333–9
    - firm-wide economic capital 329–33
  - implementation and application 325–7
  - Portfolio Manager, KMV 306, 307–8
  - Portfolio Risk Tracker 308
  - risk-adjusted performance measures 341–3
  - simulation-based 297
    - correlated asset realizations 297–9
    - default losses 304–5
    - flow chart 298
    - mark-to-market losses 301–4
    - migration events 299–301
  - structured product models 311–12
  - Vasicek one-factor model 294–7
- portfolio risk analysis 163–4
- portfolio risk measures 32, 278
  - economic capital 284
  - expected loss (EL) 278–9
  - expected shortfall 285
    - loss standard deviation 280–2
    - value-at-risk (VaR) 282–4
  - positive outlooks 119
- postal savings banks 15
- “p” ratings 119
- precision monitoring 271
- prediction horizon 239, 241–2
- preferred stocks 60
- preliminary (expected) ratings 120
- pre-payment options 36
- pre-processing 256–7
- pre-settlement risk 24
- pre-underwriting consultancy 15
- price of debt instrument, reduced form
  - models 180
- price earnings (PE) ratio 61
- price–yield function 304
- pricing 39, 42, 112, 164, 466–8, 470
- pricing models 409
- principle 1–4, pillar 2, Basel II 420–7
- private banks 5, 16
- probability of default (PD) 25, 106–7, 275
  - backtesting 270
  - calibration 260–1
  - correlation with LGD 291
  - data 202, 442, *see also* data
  - default information 203–6, 211–12
    - external ratings 212–14
    - internal expert ratings 214
    - market information 214–16
  - inference from option pricing 215–16
  - Merton model 177
  - relationship to asset correlations 317, 318
  - risk models 199
  - risk ratings 125–31, 146
  - score function 258
  - segmentation 258
- probit regression 188
- problem asset definition 158
- problem loans, definition 106
- process management, operational risks 32
- process model 252, 255–62
  - database construction and preprocessing 255–7
  - documentation 263–4
  - modelling 257–62
- procyclicality 147, 476
- product information 249
- production driven strategy 44
- product status management 249
- profit 21
- profitability ratios 244, 245, 246
- profit and loss statement (P&L) 21, 22
- profit scoring 100, 105
- project finance (PF) 376
- propensity/ability support matrix 140
- property and casualty (P&C) insurance 328, 329
- proportionality factor, Basel II 312

- proprietary information protection 434
- proprietary trading desk 14–15
- pro-rata capital allocation 339
- provisional ratings 119
- “pr” ratings 119
- public funding 473
- public sector entities 207, 247–8, 361
- purchased receivables 395–7, 455
- purchase price discounts 397
- puttable bonds 66
- put options 70, 71
  
- “q” ratings 119, 125
- qualifying reference obligations 371
- qualifying revolving retail exposures (QRRE) 318, 377
- qualitative credit ratings 125
- qualitative data 235, 236–7, 245
- qualitative disclosures 436, 437–8
  - credit risk 438, 439
  - market risk 440
  - operational risk 440
- quality control 174, 266–7, 269
- quality of data 445
- quantification of risk 39, 40
- quantitative credit ratings 124–5
- quantitative data 235–6
- quantitative disclosures 436, 437
  - credit risk 438, 439–40
  - equities 441
  - market risk 440
- quantitative impact studies (QIS) 345, 452–6
- quantitative impact studies working group, CTF 58
  
- RAROC (risk-adjusted return on capital) 37, 161, 341–3, 467
- rating 115–17, 168
  - agencies *see* rating agencies
  - applications 162–5
  - benchmarking 212–14
  - bonds 215
  - claims payable and deposit ratings 138–9
  - country and country ceiling ratings 141–3
  - comparisons 147–8, 161, 166
  - default risk ratings 125–31
  - expected loss ratings 134–7
  - exposure ratings 133–4
  - external ratings 148–9, 110–11, 115, 147, 151–2
  - general minimum requirements 399–400
  - internal ratings 147, 157–62
  - issue and issuer ratings 124
  - lifetime 118–19
  - limitations 165–7
  - local and foreign currency ratings 137
  - loss ratings 131–3
  - masterscale 161–2
  - municipal ratings 139
  - national scale ratings 138
  - number of grades 160
  - one- and two-dimensional rating scales 158–9
  - outlook 119
  - point-in-time (PIT) 145–6
  - qualitative ratings 124–5
  - qualifier 119–20
  - quantitative ratings 124–5
  - rating philosophy 160–1
  - regulation 162
  - relationship to scoring systems 117–18
  - recovery ratings 131–3
  - splits 120–1, 154, 365
  - stability 147
  - stand-alone ratings 138
  - stickiness 155, 166
  - structured products 79
  - support ratings 139–41
  - system architecture 143–5
  - through-the-cycle (TTC) 146
  - time horizon 121–4
  - terminology 118–21
- rating agencies 148–9, 110–11, 115, 151–2
  - criticisms 154–5
  - default definitions 208, 209
  - differences 121
  - fees 153
  - Fitch 150–1
  - impact of regulation 155–7
  - limitations 165–7
  - Moody’s 149–50
  - rating process 152
  - revenues 153
  - Standard & Poor’s 150
- ratings-based approach 308–10, 313, 397–8
- rating system
  - architecture 143–5, 195–6
  - choice 174
  - combined models 196–9
  - coverage 401–2
  - direct and indirect models 194–6
  - empirical statistical models 181–2
    - complexity 189–90
    - cost function 186–9
    - evaluation 190–1
    - model structure 182–6
  - expert human judgement 191–4
  - expert models 191
  - financial models 174–5
    - gambler’s ruin model 178–9
    - Merton model 176–8
    - reduced form models 180–1
  - general minimum requirements 399
  - life cycle 170–4
  - limitations 165
  - masterscale 161–2
  - number of grades 160

- rating system (*cont.*)  
 one- and two-dimensional rating scales 158–9  
 point-in-time (PIT) 145–6  
 rating philosophy 160–1  
 regulation 162  
 stability 147  
 structure 175, 182–5, 195–6  
 through-the-cycle (TTC) 146
- ratio *see* data, (explanatory) variable
- real (credit) defaults 205
- receivables 228
- recourse factoring 81
- recovery 218–19  
 rate 26  
 ratings 124, 125, 131–3, 226  
 risk 114, 131  
 risk reduction 42
- reduced-form models 175–6, 180–1
- reference dataset 191, 256
- regression problems 187
- regulation 52–3, 164  
 bank rating systems 162  
 Basel Committee on Banking  
 Supervision 55–9  
 credit rating agencies 155  
 documentation requirements 263  
 effect on credit rating agencies 156–7  
 role 53–4  
*see also* Basel II Capital Accord
- regulatory capital 112, 164, 316, 327–8, 355
- regulatory risk weights 358–65
- reinsurance companies 328
- relative trends 240, 241
- relative variables 237–8
- repayment schedules 65, 66
- reporting 326, 443–9
- repossessions 219
- repricing risk 35–6, 37
- reproducibility 192
- reputation risk 37, 155, 329, 422–3
- rerating process 265
- Research Task Force, BCBS 59
- reserves 20
- residential mortgages 318, 362, 377
- residual risk 428
- resolution of default 26–7
- response scoring 96
- restrictive default (RD) 124
- restructuring 26, 219
- retail 13, 15, 17, 248–9, 318–19, 361–2, 377,  
 392–3, 455, 457–8, 465–6, 471
- retention (attrition) scoring 104
- return on assets (ROA) 341
- return on equity (ROE) 21, 341
- revaluation reserves 351
- revenues, credit rating agencies 153, 154
- reverse convertible bonds 66–7
- review process, ICAAP 424–5
- revocable letters of credit 83
- revolving credit 63
- risk 23  
 acceptance 41–2  
 avoidance 41  
 basis risk 36  
 business risk 37  
 capital 341  
 components 378–92  
 concentration risk 428–9  
 contribution 340  
 credit risk 24–9, 42–4  
 diversification 273  
 financial conglomerates 328–9  
 interaction 37–8  
 interest rate risk 30, 35, 49–51, 427, 441  
 intermediation 11–12  
 liquidity risk 33–5, 47–9  
 management 16, 23, 38–51,  
 480–2, 468–9  
 market risk 29–31, 44–6  
 measurement 169, 326, 442  
 measures 32, 216, 261, 278–85, 326  
 mitigation 42, 366–7, 370–2  
 monitoring 39, 481  
 models 168–74, 326  
 operational risk 31–3, 46–7  
 option risk 36–7  
 quantification 39, 40, 402–4, 480–1  
 reduction 41  
 reporting 165, 445, 481  
 repricing risk 35–6, 37  
 reputation risk 37  
 risk-adjusted performance 331, 341–3  
 risk-adjusted return on capital (RAROC) 37,  
 161, 341–3, 467  
 risk-based pricing 112, 164  
 risk-level aggregation 334–9  
 risk-neutral risk measures 216, 261  
 risk weighted assets (RWA) 344–5, 374  
 risk weights 312, 317, 324, 346, 357–8, 360,  
 375, 378–92, 460–1  
 transfer 42, 429  
 yield curve risk 36
- roles of banks 9–17
- roll-out plans 357
- roll-rate analysis 208, 210
- Roman banking practices 3
- Rothschild dynasty 5, 6
- Royal Exchange 4
- Russian bond default (1998) 54
- safe securities 157
- Sarbanes–Oxley act (2002) 154
- SAS 108
- savings accounts 68
- savings banks 6, 15
- savings and loans crisis, United States  
 (1982–1995) 85–6
- scale economies 328, 332

- scaling factor 388
- scenario analysis 48, 51, 233–4, 411–13
- scope, 347–8, 459–60
- score, scorecards 110, 168, 172, 198, 251
  - automated 97–8, 113
  - design 257–8
  - limitations 113–14
  - overrides 111
  - good/bad definition 210–11
  - scoring systems 168
  - validation 268
  - see also* credit scoring
- Scorex 108
- Scotland 6
- seasonality effects 102
- seasoning 127
- Second Bank of the United States 7
- secured issues 63, 67
- Securities and Exchange Commission (SEC) 157
- securitization 12, 77, 81, 112, 131, 165, 352, 362, 375, 378, 397–9, 429–30, 439–40, 455, 457–8, 475–6
- security financing transactions (SFT) 230
- segmentation 168, 170, 199–200, 257, 258–9, 268
- selection strategy 42
- selective default (SD) 124
- self-assessment 46, 419, 420–5
- semiparametric models 186
- seniority structure of debt 27, 67
- senior ratings algorithm, Moody's 136, 214
- senior unsecured debt issue ratings 126
- sensitivity analysis 411, 413
- servicer 79
- settlement risk 24–5, 37
- shadow (conditional) ratings 120
- shareholders 20, 21
- Sharpe ratio 342
- short positions 61, 69–70, 72, 73
- short-term credit ratings 121, 123, 366
- silos aggregation 333–4
- simple approach 370
- simple risk weight method 393
- simulation-based portfolio models 293–4, 297
  - correlated asset realizations 297–9
  - Credit Portfolio View 308–10
  - default losses 304–5
  - flow chart 298
  - mark-to-market losses 301–4
  - migration events 299–301
- simulation techniques, counterpart credit exposure risk 233–4
- single stock futures 75
- size of portfolios 293
- size variables 245–7
- smoothing 240
- social development level 248
- sociodemographic variables 249
- solicited ratings 120, 152–3
- Solvency II 348
- solvency risk 40
- sound capital assessment 421
- sovereigns 24, 37, 65, 124, 141–2, 247, 248, 358, 360, 376–7, 378–92, 455, 456–7, 471
- Spanish banking crisis (1978–1983) 84–5
- specialist institutions 466
- specialized lending 244, 376
- Special Mention category 158
- special purpose vehicles (special purpose entities) 77, 78, 165
- specific risk charge (SRC) 409
- speculative grade 126
- spot price 69
- spot rate 301, 302
- spreads 236, 303
- squared collateralized debt obligations 80
- “s” ratings 119
- stability 147, 253–4, 272
  - models 253–4
  - ratings 147
  - testing 272
- staging engines 448
- stand-alone ratings 124, 138, 143
- standardization of data 445–6
- standardized approach (SA)
  - credit risk 357–74, 386–8, 389
  - market risk 406–7
  - operational risk 415–16
  - see also* Basel II
- Standard and Poors (S&P) 61, 108, 115, 116, 121, 123, 132, 138, 150, 157, 208, 209
- Standard Statistics Bureau 150
- stand-by bond purchase agreements 83
- start-ups, risk estimation 179
- state bankers 5
- state bonds 65
- statistical inference techniques 189
- step-up bonds 65
- stickiness, credit ratings 155, 166
- stochastic Brownian motion processes 176, 177
- stock indexes 61, 75
- stock market crash (1929) 8
- stocks 60–1
- stock variables 235–6
- strategic advice 39–40
- strategic risk assessment 422–3
- stress testing 326, 401–2, 408, 411–13, 428, 431, 448
- strike price 70
- structural models 174–5
  - gambler's ruin model 178–9
  - Merton model 176–8
  - portfolio models 293
- structured financial products 76–81, 311–12

- subadditivity 278
  - subordinated debt 20, 27, 67, 214, 351–2, 380
  - subprime lending crisis, United States (1998–2001) 91
  - substitution formula 384
  - supervision 55–9, *see also* Basel II
  - supervisory categories 378–9
  - supervisory review process 418–27
  - support ratings 139–41, 144
  - support vector machines (SVMs) 183, 185–6
  - surplus capital 436
  - surveillance 12
  - swaps 73, 74, 75–6
  - swaptions 74
  - Swedish banking crisis (1991–1994) 88–9
  - Swiss banking crisis (1991–1996) 89
  - syndicated loans 15, 62
  - system definition 171
  - system failures 32
  - systemic risk avoidance 54
- 
- Taiwan, banking crisis (1927) 8–9
  - Takenaka plan 462
  - target (dependent) variables 105–6, 181, 202
  - tax spread 30
  - T-bond futures 74
  - technical defaults 205
  - temples 2
  - term spread 30
  - term structure 301
  - Thomson Bank Watch 150
  - through-the-cycle (TTC) rating 146, 147–8, 151, 152, 155, 166, 162, 260, 400
  - Tier 1 capital 350–1
  - Tier 2 capital 351–2
  - Tier 3 capital 352
  - time aspects 238–42
  - time horizons 45, 230, 121–4, 400
  - top-down portfolio models 293
  - total capital ratio 352
  - total return swaps 75–6
  - trading book 31, 35, 58, 406, 430
  - training data sample 191
  - tranching 77–9, 78
  - transfer of risk 42
  - transfer risk 137
  - transformations 183, 184
  - transition (migration) matrices 127, 130
  - transition period 347
  - translation invariance 278
  - transparency 156, 192
  - “r” ratings 120
  - Treasury bonds 65
  - treasury services 16
  - treatment of risk 41–2
  - trends 240–1
  - trigger (knock-in) options 71
  - trustee 79
- 
- two-dimensional rating system 158–9, 162
  - type-I and type-II errors 413–14
- 
- UCITS (Undertakings for Collective Investments in Transferable Securities) 367
  - uncertain exposure 230–1
  - unconditional portfolio models 292–5
  - uncovered (naked) options 71
  - underestimation of risk 259
  - underwriting 64
  - undisclosed reserves 351
  - unexpected loss 279, 280, 285–9
  - unfocused strategy 44
  - United Kingdom 84, 88
  - United States 6, 7, 84, 85–6, 91, 243, 461–2
  - universal banks 13–15, 16, 465
  - unlikeliness to pay 207
  - unrated facilities 363
  - unsecured issues 67, 380
  - unsolicited ratings 120, 152–5, 366
  - upgrades 111, 127
  - usage guidelines 264
  - user guides 263
  - use-test 408
- 
- validation 173–4, 253, 265–9, 405
  - validation subgroup, AIG 57
  - valuation policies 430
  - value-at-risk (VaR) 30, 45, 279, 282–4, 283, 314–16, 408–11, 440
  - VaR haircuts 369
  - VaR models, stress testing 411, 412
  - value driven strategy 43
  - variable
    - absolute and relative 237–8
    - averages 238–40
    - definition 242–3
    - history 239
    - most recent value 238
    - past value 238
    - see also* data, explanatory variable
  - variable-income securities 19
  - variable time horizon 230
  - variance/covariance approach 410
  - Vasicek one-factor model 294–7
  - venture capital 473–4
  - volatility 245, 368, 376, 411
- 
- warehouse optimization 472–3
  - warrants 73
  - watch grades 160
  - watchlists 119
  - weighted averages 239–40
  - weights 182
  - “white box” models 195
  - withdrawal of ratings 118–19

- workout LGD 217, 218–24, 261
- workplace safety 31, 32
- World Bank 59
- worst conditional expectation *see* expected shortfall
  
- yield of bonds 64
- yield curve risk 36
  
- yield curves 301–2
- yield spread 30
- young firms 179
  
- zero-coupon bonds 65, 301
- zero risk weights 360
- zip-code 110
- z-score model (Altman) 100–1, 181, 182