

Creo[®] Parametric Essentials Packages

Design smarter with powerful, easy-to-use 3D CAD solutions

PTC's 3D CAD product design solution, Creo Parametric, gives you the right tools to achieve the highest quality designs in the fastest possible time. After all, that's not just any product - it's yours. And when you subscribe to a Creo Parametric Essentials package, you ensure that you always have the latest capabilities, premium support, and the flexibility to choose exactly what you need. With Creo Parametric Essentials, you'll be more productive than ever thanks to the industry's most robust 3D product design toolset and exciting new functionalities.

Creo Parametric Essentials Packages - At a Glance

	ESSENTIALS PREMIUM	ESSENTIALS PLUS	ESSENTIALS
3D Part & Assembly Design	●	●	●
Automated 2D Drawing Creation & Update	●	●	●
Multi-CAD data exchange (Unite Technology)	●	●	●
Parametric & Freestyle Surfacing	●	●	●
Assembly Management & Performance Tools	●	●	●
Sheet Metal Design	●	●	●
Mechanism Design	●	●	●
Plastic Part Design	●	●	●
Structural Framework & Weld Design	●	●	●
Realistic Rendering and 3D Animation	●	●	●
Direct Modeling (Flexible Modeling)	●	●	●
Basic Part Analysis	●	●	●
Intelligent Fastener Design	●	●	●
3D Printing	●	●	●
Augmented Reality	●	●	●
SUBSCRIPTION BENEFITS			
Design Exploration	●	●	●
Human Factors Design	●	●	●
Standard eLearning Library	●	●	●
Extended License Borrowing	●	●	●
Home Use	●	●	●
Performance Advisor	●	●	●
Securely vault all product data	●	●	
Powerful Search tools	●	●	
Revision Control	●	●	
Structural Analysis for Parts & Assemblies	●		
Motion Analysis	●		
Piping/Tubing Design	●		
Cabling/Wiring Design	●		

● Additional functionality when you subscribe to Creo



Augmented Reality

- Share your design with anyone
- Engaging design reviews made simple
- Author and publish an AR experience right from Creo – then download the free ThingWorx View app to see it
- Summon a 3D version of your product with a few clicks

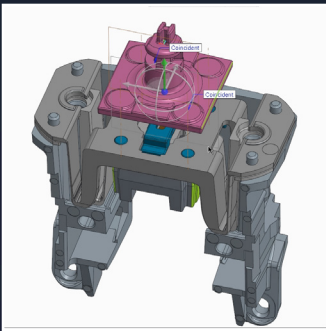

3D Part & Assembly Design

- Create precise geometry, regardless of model complexity
- Quickly build robust engineering features such as rounds, chamfers, holes, and more
- Create design variants using family tables
- Smarter, faster assembly modeling performance
- Static and dynamic interference detection

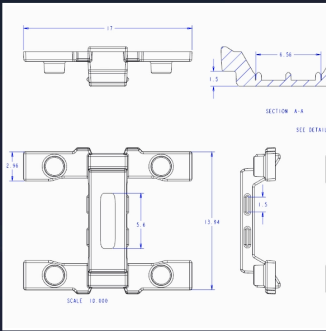

Automated 2D Drawing Creation & Update

- Create 2D and 3D drawings according to international standards, including ASME, ISO, and JIS
- Automate the creation of drawings with templates
- Automatically create associative bill of materials (BOM) with balloon notes

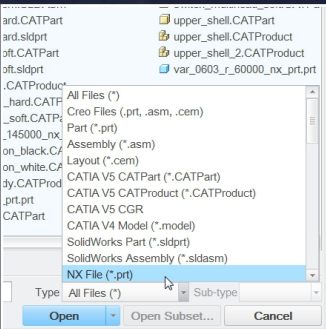

Multi-CAD data Exchange (Unite Technology)

- Incorporate non-Creo data directly into your designs easily and quickly
- Work with a number of standard file formats including STEP, IGES, DXF, STL, VRML, AutoCAD DWG, DXF (import of 3D with associated 2D), ACIS import/export, Parasolid import/export
- Using Unite technology, convert data from other CAD systems including: CATIA, Siemens NX, SolidWorks, Autodesk Inventor, Solid Edge

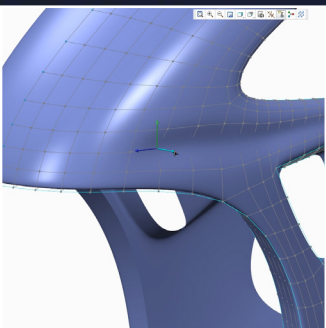

Parametric & Freestyle Surfacing

- Develop complex surface geometry using sweeps, blends, extends, offsets, and a variety of other specialized features
- Quickly create freeform shapes and surfaces using sub-divisional modeling capabilities
- Parametrically control Freestyle geometry by aligning to existing curves or edges with tangency control



Assembly Management & Performance Tools

- Load large assemblies quickly using lightweight representations
- Create simplified representations 'on-the-fly'
- Share lightweight yet fully accurate model representations using the unique Shinkwrap tool

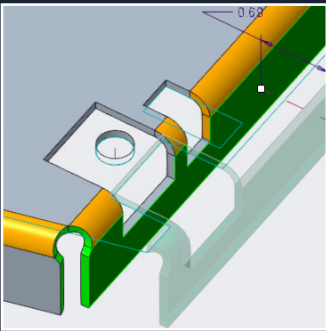

Sheet Metal Design

- Easily create walls, bends, punches, flanges, forms, and reliefs using the streamlined user interact
- Automatically generate flat patterns from 3D geometry
- Dynamically preview formed and flattened sheetmetal designs simultaneously
- Easily convert solid parts to sheetmetal
- Simply define sheetmetal design parameters, e.g. bend allowances

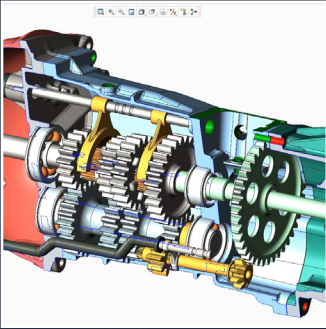

Mechanism Design

- Create mechanical connections
- Validate the kinematic motion of your design
- Create accurate motion envelopes for use in interference and space claim studies

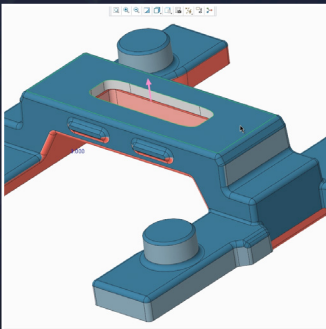

Plastic Part Design

- Comprehensive Analysis tools including draft and 3D thickness evaluation
- Mold filling simulation capabilities
- Integrated measurement tools

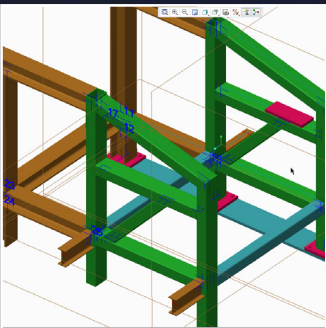

Structural Framework & Weld Design

- Dramatically reduce the time to create accurate structures, frames, or assembly lines
- Optimized user interface for the structural framework design process
- Extract valuable information from the model, such as mass properties, clearances, interferences, and cost data
- Easily produce complete 2D weld documentation

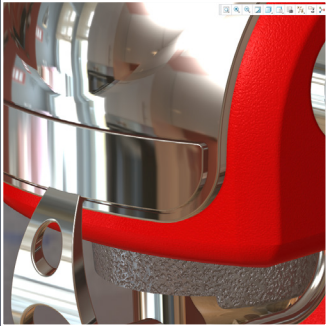

Rendering and 3D Animation

- Create accurate, realistic, images of products quickly, while rendering even the largest assemblies
- Shade with reflections for displaying different material classes such as metal, glass, paint, and plastic
- Create assembly/disassembly animations directly from the modeling environment

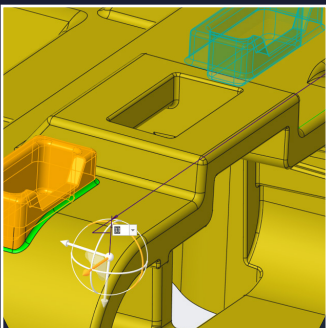

Direct Modeling (Flexible Modeling)

- Make changes to Creo data regardless of design intent – includes sheetmetal
- Modify non-Creo data regardless of origin (Solidworks, STEP, etc...)
- Recognize rounds, chamfers, patterns, and symmetry on imported geometry
- Create or recreate design intent and record edits as features

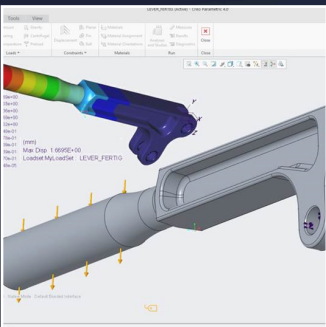

Basic Part Analysis

- Basic support for the static structural analysis of parts*
 - Intuitive Process Guide steps users through model setup and analysis
 - Full results reporting functionality and upward compatibility to Creo Simulate
- * Functional limitations (i.e., model size, loads, constraints)

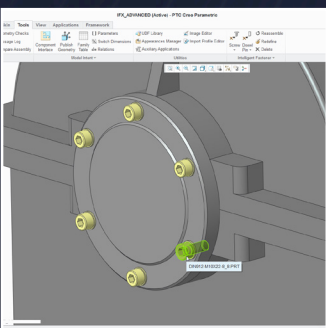

Intelligent Fastener Design

- Automate the creation of holes and assembly fasteners
- Access to standard libraries (ANSI, DIN, JIS)
- Integrated web-based component catalog
- Download predefined parts and symbols using the J-Link Programmatic Interface

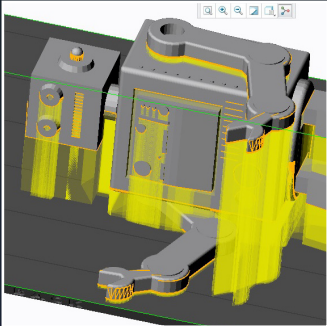

3D Printing

- Go from concept to print check all in one design environment, reducing overall process time, tedium, and errors
- Connected printer support (Stratasys and 3D systems printers)
- Print Check, material usage, and print times
- Direct connection to service bureaus

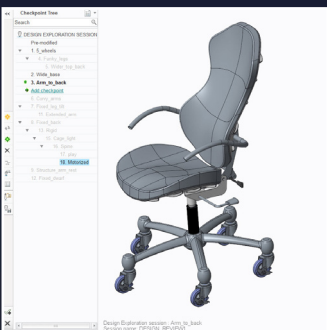

Design Exploration

- Explore design changes safely without risking original designs or committing to any change
- Simultaneously develop different ideas and evaluate all options before making decisions
- Eliminate manual data duplication and session clean-up for loading and reloading different versions

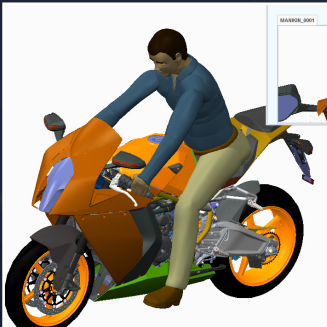

Human Factors Design

- Quickly insert and customize digital human models to prevent ergonomic mismatches and reduce prototype costs
- Easily manipulate manikins
- Visualize human reach and vision

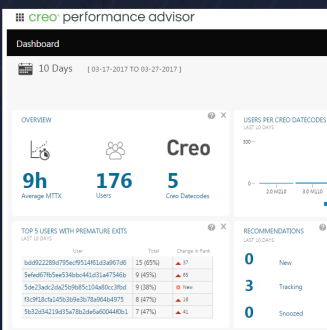

Performance Advisor

- Provides insight into the health of your Creo environment
- Proactively provides approved solutions to identified issues
- Configurable user-friendly dashboard
- Review Creo performance through hardware, product, and individual user views

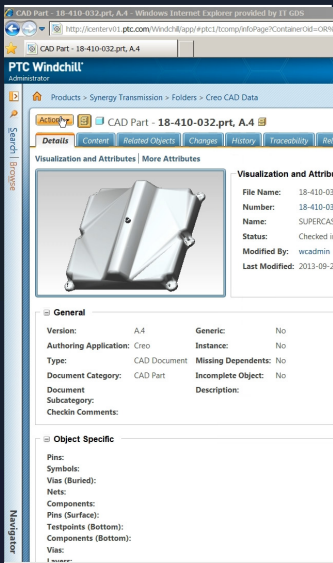

Product Data Management (PDM)

- Secures CAD models, their structures and relationships (Creo, AutoCAD, SolidWorks, Inventor, Pro/ENGINEER, Creo Elements/Direct, and PTC Mathcad) improving control and collaboration. Manage office documents, such as Microsoft Word and Excel, tracking changes through check in and check out functionality
- Embedded 3-D view and markup utilities – Allows non-CAD consumers to view, section, measure and markup designs
- Powerful searching tools – Quickly and easily search, copy or rename designs improving product information discovery and design reuse
- Fast deployment through installation and configuration wizards which greatly simplify set-up time and provide your organization with quicker time-to-value

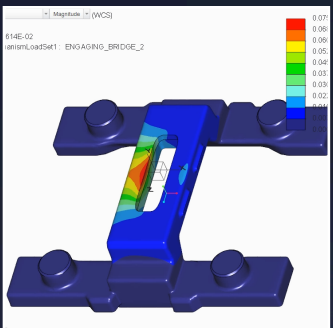

Structural Analysis for Parts and Assemblies

- Conduct standard linear static analysis on parts and assemblies
- Fast, automatic meshing and solution convergence
- Comprehensive customizable materials library

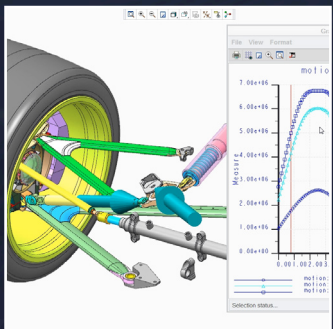

Motion Analysis

- Calculate dynamic forces based on loads
- Incorporate springs, dampers, motors, friction, gravity, and custom dynamic loads to evaluate product performance
- Use design studies to optimize the mechanism's performance over a range of input variables
- Create high-quality animations directly from dynamic simulations

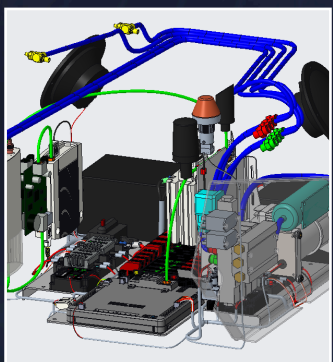

Piping & Cabling Design

- Full routing capabilities (including automated ribbon cabling and specification-driven design and auto-routing), speed design, and adherence to design rules and schematic logic
- Customizable library of standard fittings and connectors
- Associative harness manufacturing capabilities include automatic development of flat patterns
- Automatic creation of supporting documentation including isometric drawings, bend tables, nail board drawing, associative wire lengths, and bills of material

Why Subscribe to Creo Parametric Essentials?

Get more when you subscribe to Creo. More power, flexibility, and convenience than a perpetual license, at a price that won't break the bank.

Included in every package:

- **Creo Design Exploration Extension:** Quickly and easily try out new design ideas, explore alternatives within existing designs, and keep track of the decision points along the way. It's all about exploration: you won't risk your original design nor do you have to commit to any changes.
- **Human Factors Design:** You need 'people.' Insert a manikin into your 3D product model and get an early start on preventing ergonomic mismatches. Visualize, simulate, optimize and communicate these human-product interactions earlier in the design process.
- **Standard eLearning Library:** Stop searching for answers. Over 140 hours of training are now at your fingertips.
- **Extended License Borrowing:** Working remotely just got easier. Borrow floating licenses for up to 180 days - 150 days more than perpetual.
- **Home Use:** Leave the laptop at work. Every package now includes a home use license of the Creo Parametric Essentials package.
- **Performance Advisor:** The Creo Performance Advisor provides a dashboard for your entire Creo installation, allowing you to understand and optimize the performance of your entire Creo environment.

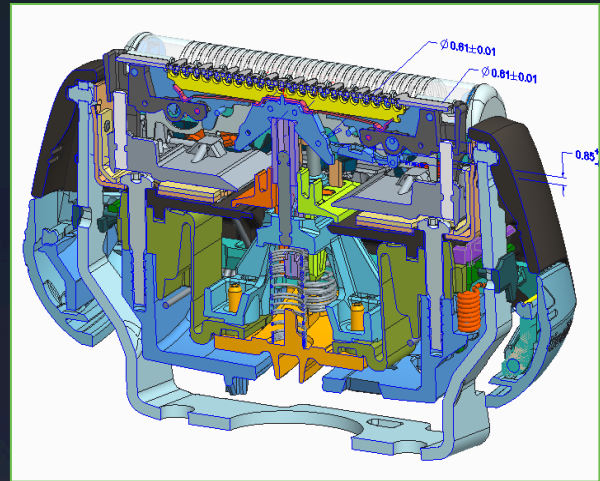

More Power When You Need it With Creo Parametric Extensions

When you're ready, we're ready. We have proven, easy-to-use extensions to handle such design tasks as freeform surfacing, simulation, photorealistic rendering, advanced assemblies, and additive manufacturing. And the Creo suite of NC and tool design so lutions ensures your costs stay low while your product quality remains high. Finally, get more from your CAD model when you design for connectivity, use an MBD (model-based definition) approach to design, or connect your model seamlessly to PLM systems.

© 2017, PTC Inc. All rights reserved. Information described herein is furnished for informational use only, is subject to change without notice, and should not be taken as a guarantee, commitment, condition or offer by PTC. PTC, the PTC logo, and all other PTC product names and logos are trademarks or registered trademarks of PTC and/or its subsidiaries in the United States and other countries. All other product or company names are property of their respective owners.

J9674-Creo-Parametric-Essentials-Packages-0714