

# Creo® Parametric™

THE ESSENTIAL 3D PARAMETRIC CAD SOLUTION

Design smarter both today and tomorrow. Creo Parametric positions you to be more productive than ever with the most robust 3D product design toolset and the new functionality you will need to design the products of the future.

## Where breakthrough products begin

Creo Parametric gives you access to a richer, more efficient product design experience backed by our global resources and decades of success. With Creo Parametric, and its extensions, you can create, analyze, view, and share designs downstream using 2D CAD, 3D CAD, parametric and direct modeling capabilities. Take advantage of breakthrough capabilities in additive manufacturing, model-based definition (MBD), and smart connected design. You can even reuse your CAD data to create AR (augmented reality) experiences easily.

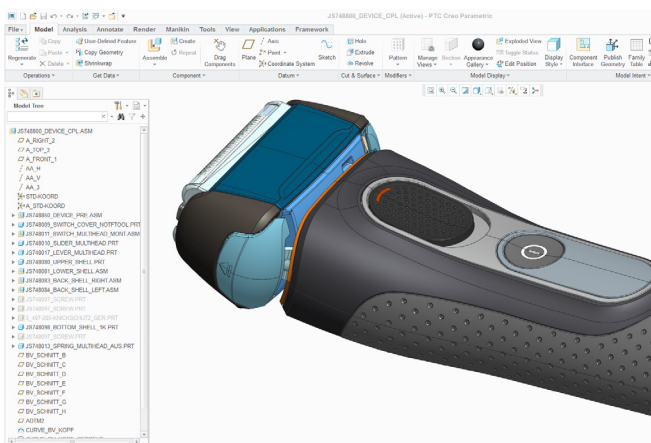

Create High Quality 3D models of your product designs.

## Key benefits

- Increase productivity with more efficient and flexible 3D detailed design capabilities
- Quickly and easily create 3D models of any part or assembly
- Dedicated toolset for working with large assemblies
- Create manufacturing drawings automatically with complete confidence that they will always reflect your current design
- Improve design aesthetics with comprehensive surfacing capabilities
- Repurpose neutral and non PTC CAD data from customers and suppliers easily, avoiding the need to convert files or recreate 3D models from scratch
- Instant access to a parts library including screws, bolts, nuts, and washers
- Get instant access to comprehensive learning materials and tutorials from within the product to get productive faster

## Never compromise

Based on the proven technology of Pro/ENGINEER® and chosen by tens of thousands of companies worldwide, Creo Parametric offers the newest, most innovative 3D CAD capabilities for your detailed design process. As a design professional, you can't risk having CAD tools that compromise your product,

process, or productivity. With the software, you never compromise because you have the exact tools you need to get the entire job done accurately and quickly.

### Creo Parametric capabilities

#### 3D solid modeling

- Create precise geometry, regardless of model complexity
- Automatically dimension sketches for fast, easy reuse
- Quickly build robust engineering features such as rounds, chamfers, holes, and more
- Create part variants using family tables

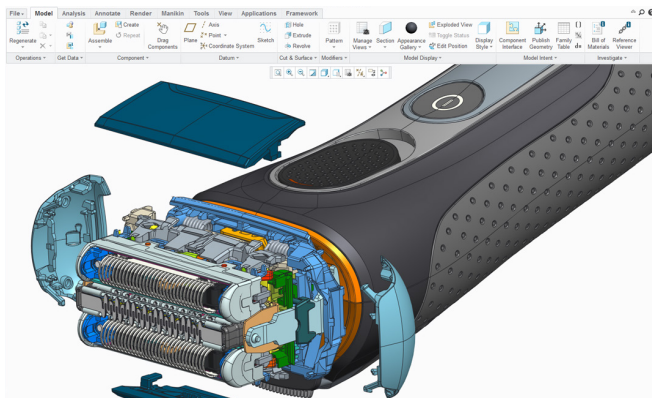

The intuitive user interface streamlines design tasks.

#### Robust assembly modeling

- Enjoy smarter, faster assembly modeling performance
- Create simplified representations 'on-the-fly'
- Share lightweight yet fully accurate model representations using the unique Shrinkwrap™ tool
- Leverage real-time collision detection

#### Detailed documentation including 2D and 3D drawings

- Create 2D and 3D drawings according to international standards, including ASME, ISO, and JIS

- Create an associative Bill-of-Material (BOM) and associated balloon notes automatically
- Automate the creation of drawings with templates

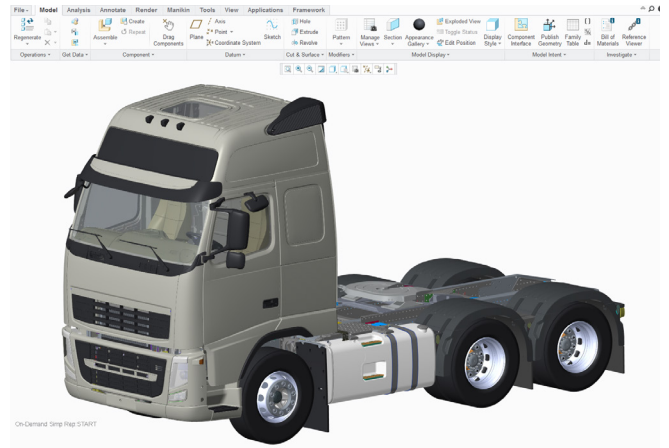

Build assembly models of any size faster using best-in-class component placement capabilities.

#### Technical surfacing

- Develop complex surface geometry using sweeps, blends, extends, offsets, and a variety of other specialized features
- Trim/extend surfaces using tools such as extrude, revolve, blend, and sweep
- Perform surface operations such as copy, merge, extend, and transform
- Define complex surface geometry

#### Freestyle surfacing

- Quickly create freeform shapes and surfaces using sub-divisional modeling capabilities
- High-quality, parameterized surfaces can be immediately reused in a 3D detailed design process
- Multilevel subdivisional modeling for more control over the surface, enabling finer detailing without altering the existing shape
- Parametrically control Freestyle geometry by aligning to existing curves or edges with tangency control

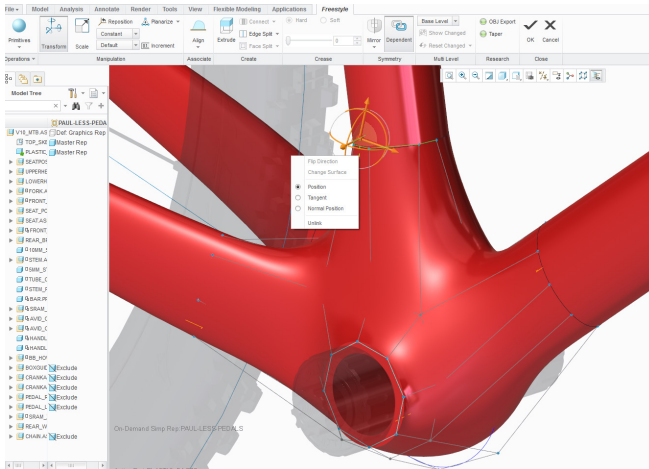

Accelerate concept design with Creo Parametric.

### Sheetmetal modeling

- Create walls, bends, punches, notches, forms, and reliefs using the streamlined user interface
- Automatically generate flat patterns from 3D geometry
- Use a variety of bend allowance calculations to create flat patterns of the designs

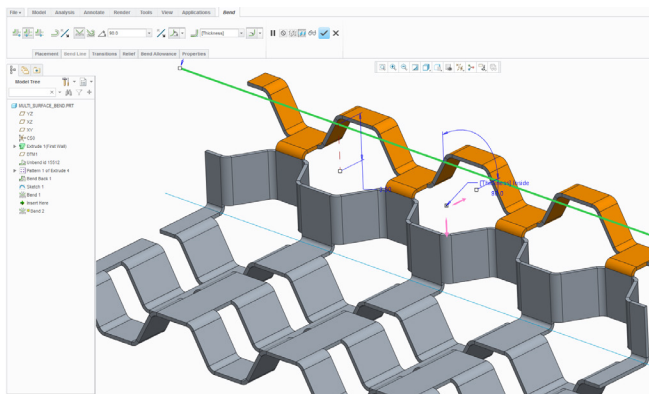

Create sheetmetal geometry using functionality to automatically apply bend relief, create sheetmetal rips, bend coplanar geometry, and more.

### Digital human modeling

- Insert and manipulate a digital human inside your CAD model
- Gain valuable insight about interactions between your product and people who manufacture, use, and service the product earlier in the design cycle

### Weld modeling and structural framework design

- Optimized user interface for the structural framework design process
- Define joining requirements
- Extract valuable information from the model, such as mass properties, clearances, interferences, and cost data
- Easily produce complete 2D weld documentation
- Intelligent component library and automatic creation of downstream deliverables for faster frame design than standard techniques

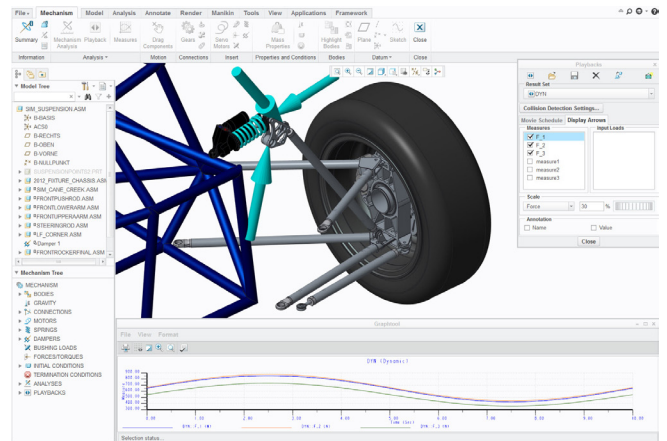

Mechanism Design lets you create mechanical connections and simulate motion on kinetic assemblies.

### Analysis features

- Perform basic static structural analysis on parts and assemblies
- Validate the kinematic motion of your design
- Interoperability with Mathcad® engineering calculation software lets you integrate Mathcad worksheets with your design to predict behavior and drive critical parameters and dimensions ( Mathcad optionally available)
- Add Microsoft® Excel® files to your design
- Integrated analysis and measure tools including draft and 3D thickness evaluation

## Graphic experience and integrated design animation

- Shade with reflections for displaying different material classes such as metal, glass, paint, and plastic. Produce realistic interaction representations of these appearance types on the model while still being able to dynamically make changes
- Create accurate, photorealistic images of products quickly, while rendering even the largest assemblies
- Make dynamic geometry changes while maintaining effects such as shadows, reflections, textures, and transparency
- Create assembly/disassembly animations directly from the modeling environment
- Reuse models easily, with the option to include mechanism simulation

## Design for Additive Manufacturing

- Define settings for multiple 3D printers
- Position, scale and show a clipped view of the 3D model and support material on the printer tray
- Quickly perform 3D printability checks and easily correct identified issues
- Print parts and assemblies, define surface finishes, materials, colors and calculate build and support material directly from Creo using a Stratasys Connex printer

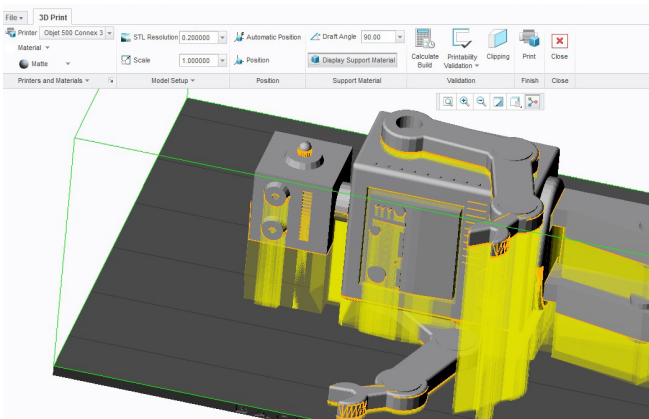

Position the model on the print tray and view the required supporting material in Creo.

## Data exchange

- Work with a number of standard file formats including STEP, IGES, DXF, STL, VRML, AutoCAD DWG, DXF (import of 3D with associated 2D), ACIS import/export, Parasolid import/export\*
- With the use of Unite technology, convert data from other CAD systems including: CATIA®, Siemens® NX™, SolidWorks®, Autodesk®, and SolidEdge®
- Incorporate non-Creo data directly into their designs without creating additional business objects or files to manage
- Support export of non-Creo formats (CATIA, Siemens NX, SolidWorks) as well as associative updates with additional purchased capabilities\*

## Working with imported non-Creo Data

- Use Import Data Doctor (IDD) to repair, modify, or featurize geometry imported into Creo Parametric from external sources
- Check and report geometric defects in a model such as surfaces, edges, and vertices
- Use IDD's repair tool to find and close gaps, repair poorly defined wireframes, and repair unsatisfied tangency

## Integrated NC capabilities

- Create 2-1/2-axis milling programs in less time
- Machine prismatic parts with 5-axis positioning
- Full support for multi-head machining centers with synchronization

## Web capabilities provide instant access

- Internet/Intranet support for fast access to email, FTP, and the Web – all from within Creo Parametric
- Seamless access to PTC Windchill® for content and process management

\*Requires Creo Collaboration Extensions

### Complete library of parts, features, tools, and more

- Fully integrated fastener library
- Integrated web based component catalog
- Download predefined parts and symbols using J-Link Programmatic Interface
- Quickly position and insert fasteners and associated nuts, washers etc. using intelligent fastener capability

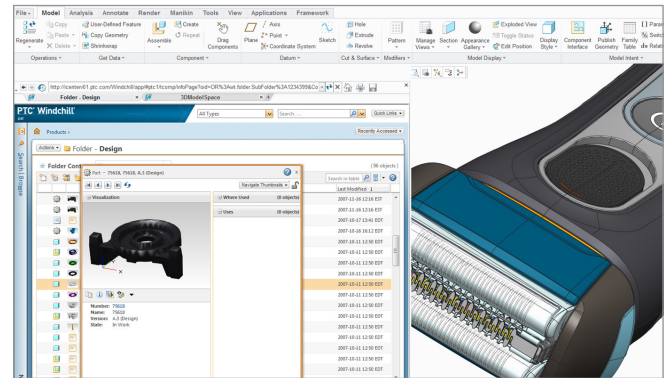

Leverage Web connectivity for information-gathering, part catalogs, and optional Product Data Management (PDM) and collaboration solution access.

### Easy to expand, impossible to outgrow

The unlimited scalability of the software means you can easily add new users, new modules, and new capabilities as your business and your needs continue to grow, and you'll never have to worry about importing incompatible data or learning a new user interface. Add-on extensions seamlessly provide extended capabilities including the following products:

#### 3D CAD – Advanced design solutions

Creo provides a number of advanced, specialized capabilities to meet the broad range of designers' needs. From structural frameworks to digital human models, Creo extensions help you capture more of your design in 3D

- |  |   |
|--|---|
| <ul style="list-style-type: none"> <li>• Creo Flexible Modeling Extension</li> <li>• Creo Options Modeler Extension</li> <li>• Creo Layout Extension</li> <li>• Creo Advanced Assembly Extension</li> <li>• Creo ECAD-MCAD Collaboration Extension</li> <li>• Creo Advanced Framework Extension</li> </ul> | <ul style="list-style-type: none"> <li>• Creo Manikin Extension</li> <li>• Creo Piping and Cabling Extension</li> <li>• Creo Intelligent Fastener Extension</li> <li>• Creo Harness Manufacturing Extension</li> <li>• Creo Design Exploration Extension</li> </ul> |
|--|---|

#### 3D CAID extensions

Creo delivers the capabilities you need to create the precise shapes, surfaces, and aesthetics of your design. Unleash your creativity and show your designs "in the best light" with Creo CAID products

- |  |  |
|--|--|
| <ul style="list-style-type: none"> <li>• Creo Interactive Surface Design Extension</li> <li>• Creo Advanced Rendering Extension</li> </ul> | <ul style="list-style-type: none"> <li>• Creo Reverse Engineering Extension</li> </ul> |
|--|--|

### 3D CAE extensions

Verifying the performance of your designs early in the process can help you get to the end-result faster. That's why Creo provides design engineers with a broad range of integrated simulation and analysis capabilities to help them design with confidence

- |   |   |
|---|---|
| <ul style="list-style-type: none"> <li>• Creo Simulation Extension</li> <li>• Creo Advanced Simulation Extension</li> <li>• Creo Behavioral Modeling Extension</li> <li>• Creo Fatigue Advisor Extension</li> <li>• Creo Mechanism Dynamics Option</li> </ul> | <ul style="list-style-type: none"> <li>• Creo Mold Analysis Extension</li> <li>• Creo Spark Analysis Extension</li> <li>• Creo Manikin Analysis Extension</li> <li>• Creo Tolerance Analysis Extension</li> </ul> |
|---|---|

### 3D NC and Tooling extensions

Streamlining tooling design and manufacture can accelerate your time to market. Creo NC and Tooling solutions provide a broad range of mold, tool, and die design and machining capabilities so you can leverage your 3D CAD data – thereby saving time and reducing errors

- |  |   |
|--|---|
| <ul style="list-style-type: none"> <li>• Creo Progressive Die Extension</li> <li>• Creo Expert Moldbase Extension</li> <li>• Creo NC Sheetmetal Extension</li> <li>• Creo Prismatic and Multi-Surface Milling Extension</li> </ul> | <ul style="list-style-type: none"> <li>• Creo Production Machining Extension</li> <li>• Creo Complete Machining Extension</li> <li>• Creo Complete Mold Design Extension</li> <li>• Creo Computer-Aided Verification Extension</li> <li>• Creo Tool Design Extension</li> </ul> |
|--|---|

### Multi-CAD data exchange and other products

Creo Parametric provides native data exchange with numerous 2D and 3D file formats. The following add-on extensions also provide associative interoperability and other capabilities, such as distributed processing, interoperability with 3rd-party applications, and more

- |   |   |
|---|---|
| <ul style="list-style-type: none"> <li>• Creo Distributed Batch Extension</li> <li>• Creo Collaboration Extension for CATIA V4/V5</li> <li>• Creo Collaboration Extension for SolidWorks</li> </ul> | <ul style="list-style-type: none"> <li>• Creo Collaboration Extension for UG/NX</li> <li>• Creo Interface for JT</li> <li>• Creo Legacy Data Migration Extension</li> </ul> |
|---|---|

© 2016, PTC Inc. (PTC). All rights reserved. Information described herein is furnished for informational use only, is subject to change without notice, and should not be taken as a guarantee, commitment, condition or offer by PTC. PTC, the PTC logo, Product & Service Advantage, Creo, Elements/Direct, Windchill, Mathcad and all other PTC product names and logos are trademarks or registered trademarks of PTC and/or its subsidiaries in the United States and other countries. All other product or company names are property of their respective owners. The timing of any product release, including any features or functionality, is subject to change at PTC's discretion.

J7544 -Creo® Parametric--EN-1016

### What is Creo?

Creo Parametric is an integral part of the Creo family of product design software.

Creo is a scalable, interoperable suite of product design software that delivers fast time to value. It helps teams create, analyze, view, and leverage product designs downstream utilizing 2D CAD, 3D CAD, parametric, and direct modeling.



**Visible Edge**

**1-888-VIS-EDGE (847-3343)**

**[sales@visible-edge.com](mailto:sales@visible-edge.com)**

**[www.visible-edge.com](http://www.visible-edge.com)**